

A FREQUENCY TRANSFER AND CLEANUP SYSTEM FOR ULTRA-HIGH STABILITY AT BOTH LONG AND SHORT TIMES FOR THE CASSINI Ka-BAND EXPERIMENT

M. D. Calhoun, G. J. Dick, and R. T. Wang
California Institute of Technology, Jet Propulsion Laboratory
4800 Oak Grove Drive, Pasadena, CA 91109, USA

Abstract

New radio science experiments, including a gravitational wave search and several atmospheric occultation studies, are planned for the Cassini Ka-band experiment. These experiments are made possible by reduced solar-induced phase fluctuations at the high frequency (32 GHz) of the radio link between the earth and the spacecraft. In order to match the improved link performance, a significant upgrade is under way to improve the frequency stability capabilities of NASA's Deep Space Network (DSN). Significant improvements are being undertaken in many areas, including antenna vibration and (wet) tropospheric calibration, in addition to frequency generation and distribution.

We describe here the design and development of a system to provide a reference signal with the highest possible frequency stability for both long-term, short-term, and phase noise, at an antenna (DSS 25) that is remote from the frequency standards room at SPC-10 at the Goldstone site. The new technologies were developed in order to meet the very tight requirements. They are: (1) a Stabilized Fiber-Optic Distribution Assembly (SFODA) that includes active compensation of thermal variations to transfer long-term stability over 16 km of ordinary fiber-optic cable, and (2) a Compensated Sapphire Oscillator (CSO) that provides short-term performance in a cryocooled sapphire oscillator with ultra-high short-term stability and low phase noise.

INTRODUCTION

The Cassini spacecraft was launched from Cape Canaveral in October 1997 for a mission to Saturn. Several gravity wave experiments are scheduled, beginning in November 2001, during the cruise phase of the spacecraft. Orbit insertion at Saturn is scheduled for July 2004. After orbit insertion, radio science occultation experiments will be conducted. These experiments require reference signals with the highest stability and the lowest phase noise imposed to date in the Deep Space Network. In order to meet the frequency standards requirements for these Cassini experiments, a new frequency generation device, the Compensated Sapphire Oscillator (CSO), has been developed at JPL and will be implemented in the DSN. The CSO has ultra-high short-term stability and very low phase noise. A hydrogen maser or a Linear Ion Trap standard (LITS) will provide the necessary long-term stability.

Report Documentation Page

Form Approved
OMB No. 0704-0188

Public reporting burden for the collection of information is estimated to average 1 hour per response, including the time for reviewing instructions, searching existing data sources, gathering and maintaining the data needed, and completing and reviewing the collection of information. Send comments regarding this burden estimate or any other aspect of this collection of information, including suggestions for reducing this burden, to Washington Headquarters Services, Directorate for Information Operations and Reports, 1215 Jefferson Davis Highway, Suite 1204, Arlington VA 22202-4302. Respondents should be aware that notwithstanding any other provision of law, no person shall be subject to a penalty for failing to comply with a collection of information if it does not display a currently valid OMB control number.

1. REPORT DATE DEC 1998		2. REPORT TYPE		3. DATES COVERED 00-00-1998 to 00-00-1998	
4. TITLE AND SUBTITLE A Frequency Transfer and Cleanup System for Ultra-High Stability at Both Long and Short Times for the Cassini Ka-Band Experiment				5a. CONTRACT NUMBER	
				5b. GRANT NUMBER	
				5c. PROGRAM ELEMENT NUMBER	
6. AUTHOR(S)				5d. PROJECT NUMBER	
				5e. TASK NUMBER	
				5f. WORK UNIT NUMBER	
7. PERFORMING ORGANIZATION NAME(S) AND ADDRESS(ES) California Institute of Technology, Jet Propulsion Laboratory, 4800 Oak Grove Drive, Pasadena, CA, 91109				8. PERFORMING ORGANIZATION REPORT NUMBER	
9. SPONSORING/MONITORING AGENCY NAME(S) AND ADDRESS(ES)				10. SPONSOR/MONITOR'S ACRONYM(S)	
				11. SPONSOR/MONITOR'S REPORT NUMBER(S)	
12. DISTRIBUTION/AVAILABILITY STATEMENT Approved for public release; distribution unlimited					
13. SUPPLEMENTARY NOTES See also ADA415578. 30th Annual Precise Time and Time Interval (PTTI) Systems and Applications Meeting, Reston, VA, 1-3 Dec 1998					
14. ABSTRACT see report					
15. SUBJECT TERMS					
16. SECURITY CLASSIFICATION OF:			17. LIMITATION OF ABSTRACT	18. NUMBER OF PAGES	19a. NAME OF RESPONSIBLE PERSON
a. REPORT	b. ABSTRACT	c. THIS PAGE			
unclassified	unclassified	unclassified	Same as Report (SAR)	8	

A problem arises in maintaining long-term stability because of the distance between the frequency standard, located at SPC 10, and the remote antenna, located 16 km away. The reference frequency transfer is via optical fibers which are subject to temperature variations, which in turn produce phase variations of the reference signal. To mitigate the effect of temperature variations on the long run of fiber cable, an active fiber compensator, the Stabilized Fiber Optic Distribution Assembly (SFODA), has been developed at JPL and will be implemented in the DSN to support the Cassini experiments at DSS 25. We present in this paper the system concept of the CSO and the SFODA. Figure 1 depicts the configuration of the CSO and the SFODA at Goldstone Tracking Station to support the Cassini experiments.

STABILIZED FIBER OPTIC DISTRIBUTION ASSEMBLY

Fiber-optic cable is the preferred medium for distributing RF signals from frequency standards to users located in tracking antennas in the Deep Space Network. A hydrogen maser or LITS is used as the source of a highly stable signal, typically 100 MHz, which is impressed on an optical carrier by intensity modulation of a laser diode. Subsequently, the signal is transmitted via buried optical cable and distributed at a remote location. The optical cable is buried at a depth of 1.5 meters, which isolates it from large temperature variations at the ground surface [1]. The same optical cable passes through three different plenums as well as splice vaults distributed over the 16 km fiber run. Cable exposure to various temperature variations results in degraded stability of the reference signal at the remote user location.

The SFODA utilizes active feedback to correct for phase variations in the reference signal. Figure 2 is a block diagram of the SFODA. A 100 MHz reference signal from a hydrogen maser or LITS frequency standard is the input to the SFODA transmitter. The 100 MHz is multiplied to 1 GHz for transmission to the remote facility. At the receiving end, the SFODA 1 GHz output is fed to the CSO for steering for long-term stability.

At the remote antenna site, the SFODA receiver houses a low noise 100 MHz VCO which is phase-locked to the stabilized 1 GHz. The 100MHz signal is mixed with the 1 GHz reference signal to produce 900 MHz and 1100 MHz to feedback over the fiber-optic link for phase correction at the source end of the fiber. At the source end, the returned 900 MHz and 1100 MHz are mixed with the reference 1 GHz and translated to 100 MHz. This 100 MHz is phase-compared with the 100 MHz reference from the source frequency standard to produce an error signal for driving the fiber compensator to correct phase variations over the long fiber link.

The fiber link from SPC 10 to DSS 25 is approximately 16 km in length. The compensator reel has 4 km of the same type fiber wound on a heat-conducting cylinder. Ground temperature variations at the burial depth of the optical fiber can be as much as 10°C seasonally; thus, the compensator reel temperature must be capable of a 40°C variation. The peltier devices which drive the compensating fiber have the ability to swing 50°, thus are capable of tracking the worst-case phase variation.

A prototype engineering model of the SFODA has been built and tested at JPL. Laboratory tests indicate that the SFODA can improve long-term stability of the fiber-optic link by approximately three orders of magnitude. This capability allows the reference frequency distribution at the remote antenna pedestal to meet the requirements levied by the Cassini radio science investigators. The scheduled delivery date for the SFODA is December 1999 at which time in-situ testing will be conducted.

COMPENSATED SAPPHIRE OSCILLATOR

Stability and phase noise performance of quartz and atomic frequency sources available to the DSN cannot meet the phase noise requirements and short-term stability goals of the Cassini Ka-band Experiment for offset frequencies below 10Hz – 30Hz. In addition to meeting *this* requirement, the Allan deviation for the CSO is better than that which is possible with hydrogen maser frequency sources for measuring times below 100 to 300 seconds. This indicates a range of at least $\times 1000$ (from 10 Hz to ≈ 0.01 Hz) over which DSN performance can be improved by the capability of the CSO.

Application to the DSN requires uninterrupted operation for periods of a year or more, a requirement that could not be met using the liquid helium cooling required by previous superconducting and sapphire technologies. While long-life 2-stage Giffard-McMahon cryocoolers are available with ultimate cooling capabilities to about 4K, this temperature is not low enough to provide high-Q operation of superconducting resonators (which require $T < 1.5K$) or even conventional sapphire resonators, with their somewhat variable turnover temperatures of typically 4K – 6K. Thermal losses associated with vibration isolation, multiple stages of thermal regulation, and with cryocooler aging must all be taken into account, indicating a minimum achievable design temperature of 7K-8K. Fortunately, the quality factor or Q of the sapphire does not degrade below a value of 10^9 until temperatures are raised above 10K, giving a design operation range of 8K-10K. We have developed a compensated resonator design procedure that allows construction of a whispering gallery resonator with turn-over temperatures in this range with typical Q's of 10^9 . For the first time it is possible to provide ultra-high short-term stability of a few parts in 10^{15} in a frequency standard that can operate continuously for a year or more.

Design details have been presented previously [2]. General features can be seen in Figure 3, which shows a schematic diagram and photo of the resonator itself, together with a plot of resonator RF fields, calculated using the CYRES-2 finite element program. As is shown in the figure, a small amount of the RF energy extends from the main sapphire resonator into the ruby compensating element, giving rise to a temperature tuning effect which can be seen in Figure 4. Here, the observable change from uncompensated to compensated performance is due to the addition of a ruby element.

Figure 5 shows a block diagram of the frequency-lock circuitry for the 10K-CSO. An 800MHz cavity stabilized oscillator provides the primary signal from which other frequencies are derived. The 100MHz and 1GHz output frequencies as specified by our requirements will also be derived from this signal.

The low 10^{-13} daily variation of the CSO allows easy application as a VCO. Configured as L.O. for the LITS trapped ion frequency standard, a frequency pulling range of more than $\delta v/v = 10^{-11}$ was found to be possible by injecting a dc voltage to the Pound frequency lock circuitry. The

combined LITS/CSO frequency standard was used to demonstrate the lowest statistical variation for any passive frequency standard to date, $3 \times 10^{-14}/\sqrt{\tau}$ [3].

While extremely effective for lower frequencies, vibrations of the cryocooler give rise to observable bright line phase fluctuations from the CSO at offset frequencies above about 50Hz. Thus, matching the capabilities of the CSO, the SFODA transfer system, and the primary standard at SPC-10 means that the CSO must follow the SFODA signal for times longer than about 300 seconds, and must also preserve the excellent phase noise of the quartz cleanup loop for frequencies above about 50Hz.

CSO stability, measured against a "hot" hydrogen maser with excellent short-term stability, is shown in Figure 6. Even with this reference, the short-term stability of the CSO cannot be seen for measuring times shorter than about $\tau = 300$ seconds. A second unit has been constructed and will soon be available for testing, and will provide an appropriate way to measure short-term stability and close-in phase noise for the first time.

ACKNOWLEDGMENT

This work was carried out at the Jet Propulsion Laboratory, California Institute of Technology, under a contract with the National Aeronautics and Space Administration.

REFERENCES

- [1] M. Calhoun, P. Kuhnle, and J. Law, "Environmental Effects on the Stability of Optical Fibers Used for Reference Frequency Distribution," *Proc. 1993 Institute of Environmental Sciences Applications Meeting*, Las Vegas, NV, May 1993.
- [2] J. Dick and R.T. Wang, "Cryocooled sapphire oscillator for the CASSINI Ka-band Experiment," *Proc. 1997 International IEEE Frequency Control Symposium*, pp. 1009-1014, 1997.
- [3] G. John Dick, Rabi T. Wang, and Robert L. Tjoelker, "Cryocooled Sapphire Oscillator with Ultra-High Stability," *Proc. 1998 International IEEE Frequency Control Symposium*, pp. 528-533, 1998.

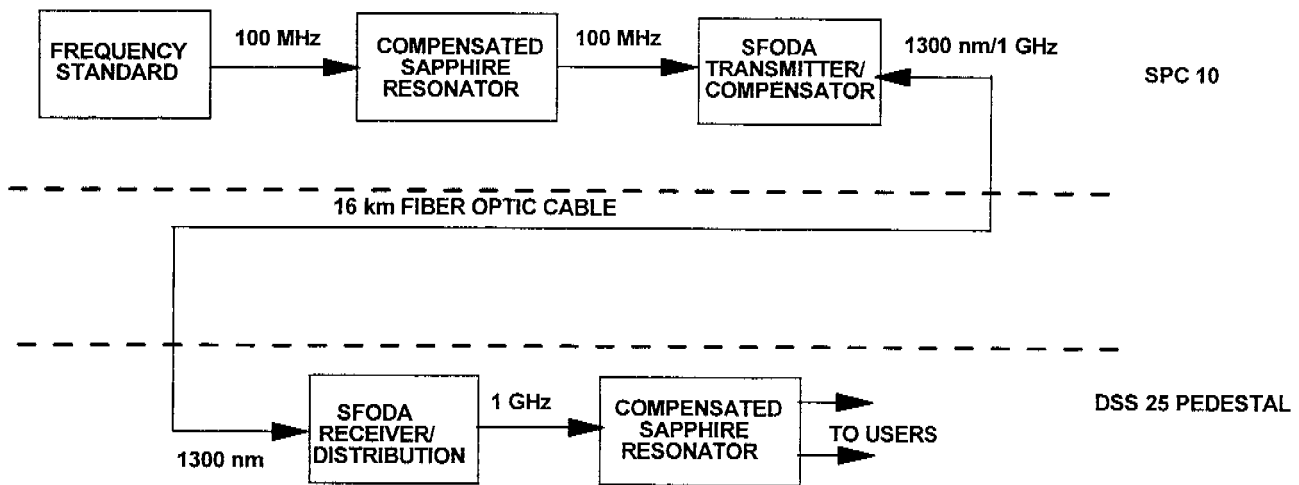

Figure 1. Reference Frequency Distribution for Cassini Ka-Band Experiment at DSS 25

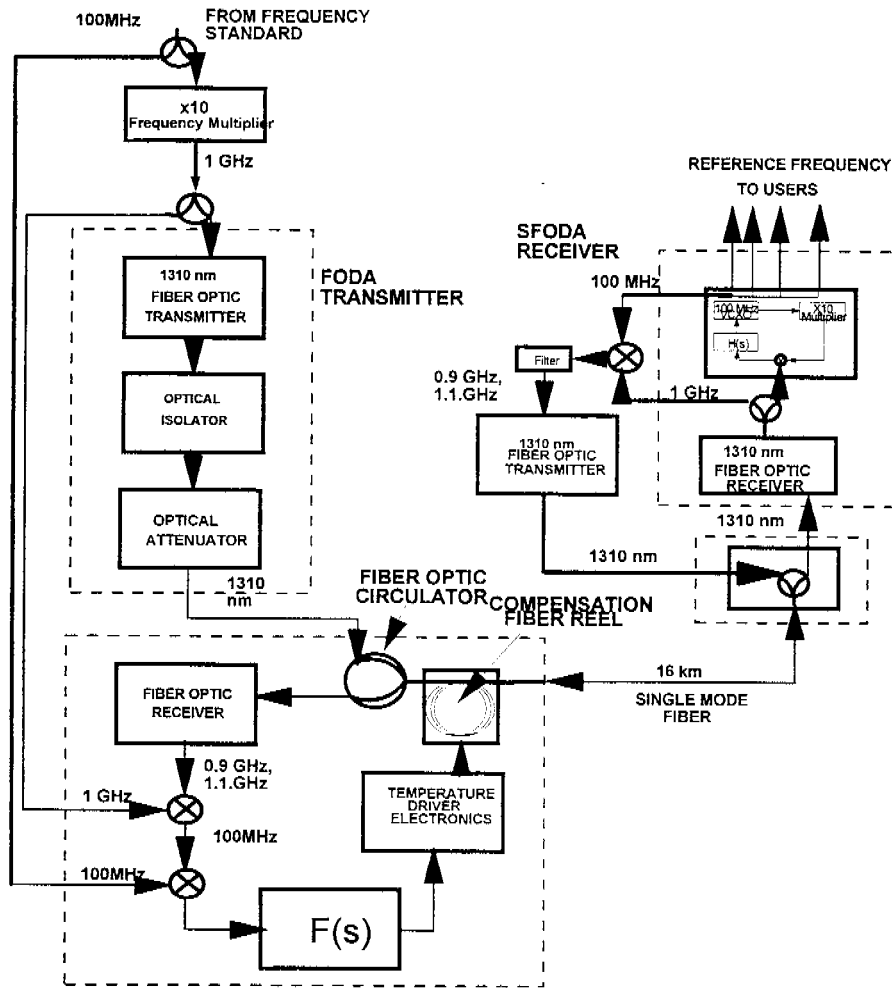

Figure 2. Phase-Stabilized Fiber-Optic Reference Frequency Distribution (SFODA)

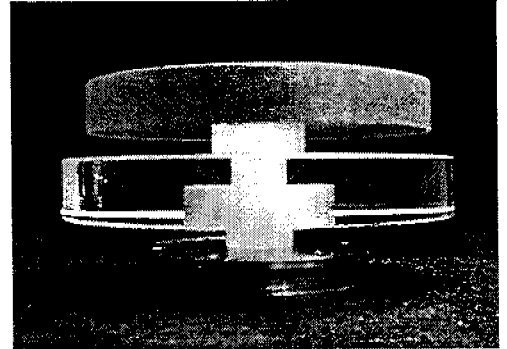
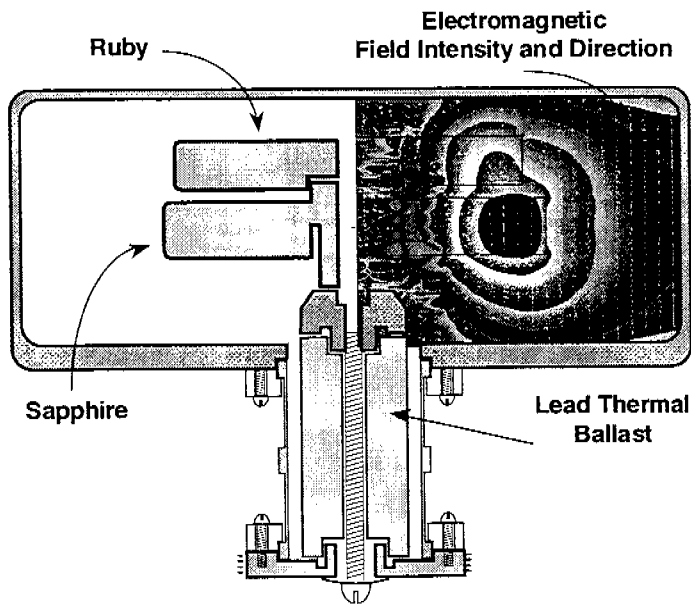

Figure 3. Compensated Sapphire Resonator. Thermally induced variations in the frequency of the sapphire resonator are canceled by paramagnetic spins in a weakly coupled ruby element.

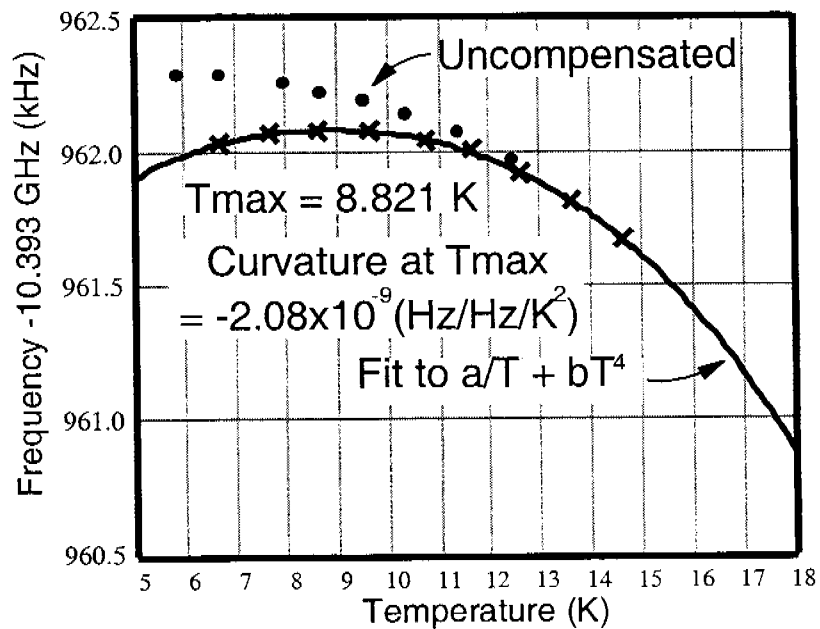

Figure 4. Measured temperature dependence of the compensated resonator with a 4mm spacing between sapphire and ruby elements. Uncompensated temperature dependence is also shown.

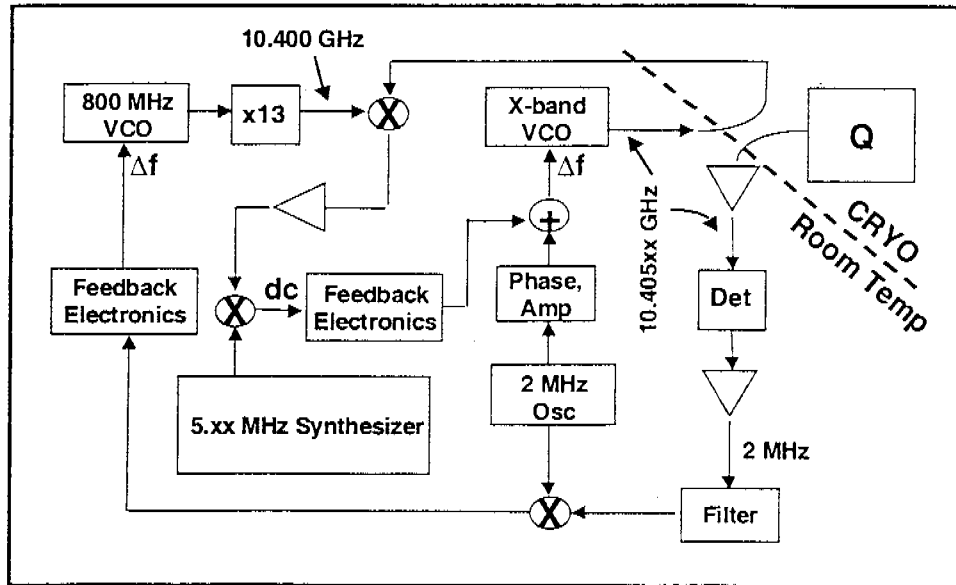

Figure 5. Block diagram of Pound circuit frequency feedback system for 10K CSO. Individual resonator frequencies vary up to + or - 20MHz from the 10.400GHz nominal operating frequency. Proper loop operation requires at least 5MHz difference, as show in this example.

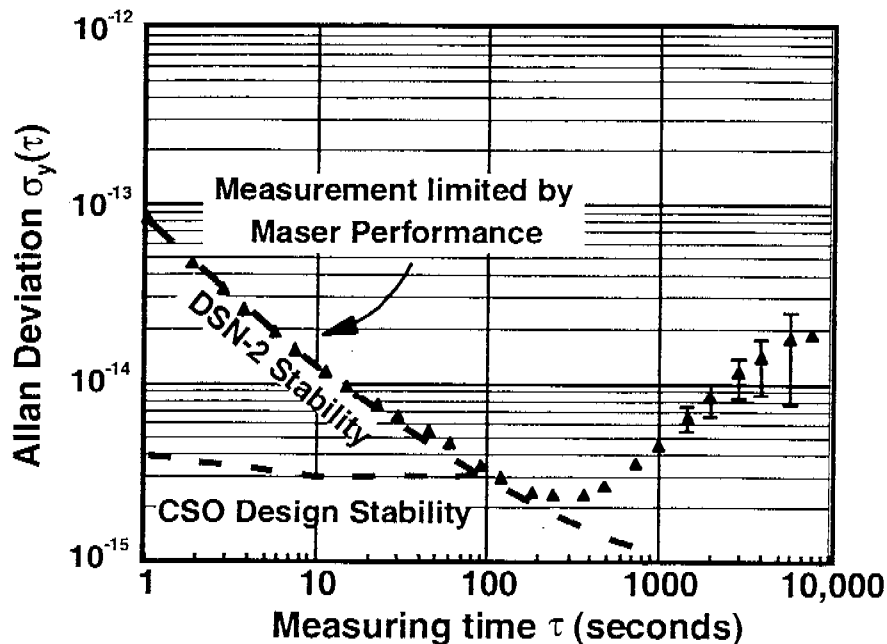

Figure 6. Measured frequency stability for the 10K CSO against a DSN-2 hydrogen maser tuned for best short-term stability. Even this "hot" H-maser reference dominates the observed short-term variation. The long-term turn-up is due to the CSO, and is likely caused by sensitivity of the rf electronics to room temperature variations.

Questions and Answers

DEMETRIOS MATSAKIS (USNO): I wonder if you have done an error budget on your old inadequate fiberoptics system and know where your errors are coming from.

MALCOLM CALHOUN (JPL): Yes we do. We have characterized the entire system and we know very well where the errors are coming from.

DEMETRIOS MATSAKIS: Can you tell us the big ones?

MALCOLM CALHOUN: The big ones are still the cables.

DEMETRIOS MATSAKIS: Expansion?

MALCOLM CALHOUN: Yes, these are approximately seven parts per million per degree C; roughly 30 picoseconds per kilometer per degree C. Very large contributors to these phase variations.

In the 70-meter net and then the 34 meter HEF-network, we have installed a passively compensated fiber that has very nearly a zero temperature coefficient. The cost is prohibitive in a 16-kilometer link and would cost \$1 million just for the cable alone. The last time we priced this cable, it was \$54 per meter for a six-fiber cable. That is 16 kilometers, or almost \$1 million. Then it is not direct burial cable, it is duct- or plenum-type cable, so we would have to build a duct all the way from the processing center to the remote location. This is not feasible. We can build an atomic frequency standard and install at the antenna for less cost than installing the passively compensated fiber.

WOLFGANG SCHAEFER (Time Tech): Have you considered the two-way links or having two fibers?

MALCOLM CALHOUN: Yes, we have looked at two-way links, and it works very well. The problem that I had was that the (WDM) Wave Division Multiplexer devices and the splitters cause an optical loss that degrades the signal-to-noise ratio. So, the method that I ended up with was the single wave link method. I get an improved signal-to-noise ratio, which helps the phase noise performance, which works very well. Also, the reflection method worked, but with the same problem again. I had a 50 percent reflector in line at the remote end; it sent the same signal back and the loss at my receiving end was too high.