

A New Method of Time Difference Measurement— The Time Difference Method by Dual “Phase Coincidence Points” Detection

Wei Zhou

Dept. of Measurement and Instrumentation, Xidian University
Xi'an, 710071, P.R.China

Abstract

In the high accurate measurement of periodic signals the greatest common factor frequency and its characteristics have special functions. This paper describes a new method of time difference measurement—the time difference method by dual “phase coincidence points” detection. This method utilizes the characteristics of the greatest common factor frequency to measure time or phase difference between periodic signals. It can suit a very wide frequency range. Measurement precision and potential accuracy of several picoseconds have been demonstrated with this new method. The instrument based on this method is very simple, and the demand for the common oscillator is low. This method and instrument can be used widely.

1. Introduction

With the greatest common factor frequency and its characteristics the high accurate measurement of periodic signals can be accomplished easily, and the equipment is very simple. The time difference method by dual “phase coincidence points” detection is a new method of time difference measurement based on the characteristics of the greatest common factor frequency. With this method the high accurate time difference measurement can be accomplished in a very wide frequency range. It is different from some frequency standard measurement method and instruments which can only be used to measure time difference at certain frequency points and the devices are complex, that this new method can be used in a very wide frequency range and the device is simple.

The greatest common factor frequency between two frequency signals is similar to the mathematical greatest common factor between two numbers. To two frequency signals f_1 and f_2 , if $f_1 = Af_c$, $f_2 = Bf_c$, the two positive integers A and B are prime with each other, then f_c is the greatest common factor frequency f_{maxc} between f_1 and f_2 . The period of f_{maxc} is the least common multiple period T_{minc} between f_1 and f_2 .

With the characteristics of the greatest common factor frequency to measure frequency and other periodic signals, the main method is to detect the “phase coincidence points” between a standard frequency signal and a measured frequency signal. The “phase coincidence point” does not mean

Report Documentation Page

Form Approved
OMB No. 0704-0188

Public reporting burden for the collection of information is estimated to average 1 hour per response, including the time for reviewing instructions, searching existing data sources, gathering and maintaining the data needed, and completing and reviewing the collection of information. Send comments regarding this burden estimate or any other aspect of this collection of information, including suggestions for reducing this burden, to Washington Headquarters Services, Directorate for Information Operations and Reports, 1215 Jefferson Davis Highway, Suite 1204, Arlington VA 22202-4302. Respondents should be aware that notwithstanding any other provision of law, no person shall be subject to a penalty for failing to comply with a collection of information if it does not display a currently valid OMB control number.

1. REPORT DATE DEC 1992	2. REPORT TYPE	3. DATES COVERED 00-00-1992 to 00-00-1992			
4. TITLE AND SUBTITLE A New Method of Time Difference Measurement- The Time Difference Method by Dual 'Phase Coincidence Points' Detection		5a. CONTRACT NUMBER			
		5b. GRANT NUMBER			
		5c. PROGRAM ELEMENT NUMBER			
6. AUTHOR(S)		5d. PROJECT NUMBER			
		5e. TASK NUMBER			
		5f. WORK UNIT NUMBER			
7. PERFORMING ORGANIZATION NAME(S) AND ADDRESS(ES) Xidian University, Dept. of Measurement and Instrumentation, Xi'an, 710071, P.R.China,		8. PERFORMING ORGANIZATION REPORT NUMBER			
9. SPONSORING/MONITORING AGENCY NAME(S) AND ADDRESS(ES)		10. SPONSOR/MONITOR'S ACRONYM(S)			
		11. SPONSOR/MONITOR'S REPORT NUMBER(S)			
12. DISTRIBUTION/AVAILABILITY STATEMENT Approved for public release; distribution unlimited					
13. SUPPLEMENTARY NOTES See also ADA267301. 24th Annual Precise Time and Time Interval (PTTI) Applications and Planning Meeting, McLean, VA, 1-3 Dec 1992					
14. ABSTRACT see report					
15. SUBJECT TERMS					
16. SECURITY CLASSIFICATION OF:			17. LIMITATION OF ABSTRACT Same as Report (SAR)	18. NUMBER OF PAGES 6	19a. NAME OF RESPONSIBLE PERSON
a. REPORT unclassified	b. ABSTRACT unclassified	c. THIS PAGE unclassified			

exact phase coincidence. It means the degree and case of the very near relative phase. It has been demonstrated that the quantized phase shift discriminability between two frequency signals is:

$$\Delta T = \frac{f_{maxc}}{f_1 f_2} \quad (1)$$

where f_{maxc} is the greatest common factor frequency between f_1 and f_2 . In a T_{minc} period the phase difference change between any two frequency signals can be quite different. Maybe it is from large to small or from small to large. Maybe the change is irregular. It depends on the relative relationship between the two frequency signals. If we rearrange the order of the quantized phase difference values by size sequence in a T_{minc} period, the change of the quantized adjacent phase difference is ΔT . According to the measuring accuracy, the "phase coincidence points" are some time difference value decided by the initial phase difference plus 0, ΔT , $2\Delta T$, $3\Delta T$, ... respectively. If the measuring gate time is composed of some time interval that starts and stops at the "phase coincidence points", there are the cycle numbers that are very close to many integral periods of the two frequency signals respectively. Using this method some high accurate measurements of frequency and periodic signals can be achieved. The ± 1 count error that occurs in ordinary frequency and time interval measurement instruments can be overcome satisfactorily. Therefore, the new instruments designed by this method can obtain 1000 times higher accuracy than that of ordinary instruments. When the instruments are designed for special purposes, their accuracy is much higher.

2. The time difference method by dual "phase coincidence points" detection

A principle block diagram of the time difference method by dual "phase coincidence points" detection is shown in Fig. 1. Fig. 2 is the waveform diagram of this method.

In Fig. 2, $f_c(t)$ is the common oscillator. Sometimes it can be the standard frequency. $f_1(t)$ and $f_2(t)$ are the two compared signals which are the same in frequency. Sometimes one of them is the standard frequency signal. The "phase coincidence points" between common oscillator signal and two compared signals are detected respectively. The measuring gate time begins with the "phase coincidence point" between $f_1(t)$ and $f_c(t)$, and ends up with the "phase coincidence point" between $f_2(t)$ and $f_c(t)$. If the frequencies of $f_1(t)$ and $f_2(t)$ are unknown (at this time $f_c(t)$ is the standard frequency), their period T_x is measured with $f_c(t)$. The measured whole time is:

$$\begin{aligned} t &= N_{x1}T_x + \Delta t \\ t &= N_{c1}T_c \end{aligned}$$

The measured time difference is:

$$\Delta t = N_{c1}T_c - N_{x1}T_x \quad (2)$$

where T_c is the period of $f_c(t)$, N_{c1} are the cycle numbers of $f_c(t)$ in the gate time t , and N_{x1} are the cycle numbers of $f_1(t)$ in the time interval $t - \Delta t$.

The measuring error is much less than ± 1 period of the count pulse, but is the value relating to the quantized phase change between the common oscillator and measurands and the phase detection discriminability of the phase detection circuit.

According to different measuring purposes the standard frequency signal can be used in different positions, and the demand for the common oscillator is different. In the measurement there are two same greatest common factor frequencies f_{maxc} between the common oscillator and the two compared frequency signals which are the same in frequency. In the general time difference, time interval measurements, the standard frequency signal is used as common oscillator. At this time the frequency relationship between common oscillator and compared frequency signals is similar to that of the frequency measurement with "The Frequency Measuring Technique by Broad-band Phase Detection". If the frequency of measured signal is close to the frequency of the standard signal or they have multiple relationship in frequency, the measurement must be accomplished by a frequency synthesizer. Some papers have described this question in detail.

In the time difference measurement of two high stable frequency signals, one of which is the standard frequency signal, the common oscillator can be a stable crystal oscillator. The frequency of the common oscillator and its frequency stability in certain period can influence the measurement. The common oscillator is an important device in the measurement system. Generally its frequency has some little frequency difference with general standard signal frequency or its multiple frequencies. The frequency difference can be chosen according to the measuring demand, and can suit most standard frequency signals. The common oscillator can be locked by the standard frequency signal, also can be not locked. It may influence the measuring accuracy obviously. Generally, in the measurement with the locked common oscillator the measuring period can be controlled easily. If the common oscillator is locked, the locked frequency can be chosen flexibly. But for ordinary synthetic frequency, that has a little integral frequency deviation based on general standard frequency or its multiple frequencies (for example, 5.0001 MHz, 10.001 MHz), the greatest common factor frequency f_{maxc} is large. It is unfavourable to further enhancing the measuring accuracy. In each least common multiple period the phase difference between the common oscillator and the two compared signals changes in one direction uniformly. In this case the measurement is very regular. The least regular period of measurement is equal to the least common multiple period. The measurement can be controlled very easily. According to equations (1) and (2), the measuring accuracy depends mainly on the detection accuracy of the "phase coincidence point" detection circuit and the quantized phase shift discriminability between the common oscillator and the two compared signals. The quantized phase shift discriminability depends on equation (1). It is not very high. Therefore, compared with the ordinary measuring technique, the new measuring method can only get a limited enhanced accuracy. With this method the ± 1 count error in the ordinary time-frequency measuring instrument can be overcome. Using a suitable frequency synthesizer, we can measure time difference in a very wide frequency range and obtain 0.2 ns or higher measuring accuracy. Because there is no non-linear circuit for frequency transformation, the direct time difference measurement can be accomplished easily when the two input circuits are identical.

When the unlocked common oscillator is used, the demand for the frequency stability of the common oscillator is high, but the synthesizer can be omitted. In this case we can obtain the very little greatest common factor frequency. It is favourable to further enhancing the measuring

accuracy. We can also get suitable measuring time and interval. When a crystal oscillator is used as the common oscillator that is not locked by the standard frequency signal, its frequency value is composed of three sections. They are the main frequency section which is equal to the frequency value of general frequency standard or its multiples (for example, 5 MHz, 10 MHz), some regular low frequency difference (1 kHz or 100 Hz etc.), and some unfixed little frequency deviation. In this case, a regular distribution of "phase coincidence points" can also be obtained. It is different from a frequency synthesizer as the common oscillator that the unlocked common oscillator has the unfixed little frequency deviation. The third section is important to the measurement. In this case the greatest common factor frequency between the common oscillator and compared signal is very little (is several Hz or much less), and it is much less than the low frequency difference section. Therefore, we can obtain higher measuring accuracy with a phase detection circuit that has a high precision. In a least common multiple period there are many periods of phase change from large to small or from small to large. There are very little differences between these corresponding phase differences that are in different periods of phase change. The period number of the phase change in a least common multiple period is about equal to the ratio of the second section of the common oscillator frequency to the greatest common factor frequency. The distribution of "phase coincidence points" is uniform.

When the detection precision of the phase detection circuit is higher enough, in a T_{minc} period the detected "phase coincidence points" are less and are concentrated some range in the T_{minc} period. In this case, the distribution of the detected "phase coincidence points" is no longer uniform. Because the greatest common factor frequency f_{maxc} and the quantized phase shift discriminability ΔT are small, we have chance to get higher measuring accuracy, especially in the frequency standard comparison. Fig. 3 is the block diagram of an instrument designed by this new method.

In this instrument, the nominal frequencies of the two compared frequency signals $f_1(t)$ and $f_2(t)$ are known and the same, and one of them is the standard frequency signal. The compared signal frequency can be 10 MHz, 5 MHz, 2.5 MHz, 1 MHz or 100 KHz. These frequency values are stored in EPROM of the microcomputer. The common oscillator is a unlocked crystal oscillator. It has good short-term stability and its nominal frequency is 10.0001 MHz. However its practical frequency has several to several tens Hz deviation from 10.0001 MHz. Therefore the greatest common factor frequency between the common oscillator and the compared frequency signal is from less than 1 Hz to about several tens of Hz, and in most cases it is much less than 1 Hz. The quantized phase shift discriminability ΔT between them is less than 1 ps. The delay control signal generated by microcomputer software controls the measurement interval. The "phase coincidence" signal between $f_1(t)$ and $f_c(t)$ starts the gate time generating circuit 1 and the gate time generating circuit 2. The gate time generating circuit 1 is stopped by another "phase coincidence" signal between $f_1(t)$ and $f_c(t)$, and the gate time generating circuit 2 is stopped by a "phase coincidence" signal between $f_2(t)$ and $f_c(t)$ which follows the starting signal. The $f_1(t)$ and $f_c(t)$ signals are counted in 4 counters after 4 gate circuits. From Fig. 3, the gate signals are synchronized by corresponding signals, the counted numbers do not have ± 1 count error. From counted cycle numbers by counter 1 and counter 2, the frequency of the common oscillator can be computed. Its period is:

$$T_c = \frac{N_0 T_0}{N_c}$$

where T_0 is the period of $f_1(t)$ and $f_2(t)$, N_0 is the cycle number of $f_1(t)$ counted by counter 1, and N_c is the cycle number of $f_c(t)$ counted by counter 2. According to a different input compared frequency signal, the computer can choose the different T_0 value which has been stored in its EPROM. From cycle number N_{c1} of $f_c(t)$ counted by counter 3 and the cycle number N_{01} of $f_1(t)$ counted by counter 4, the time difference Δt between $f_1(t)$ and $f_2(t)$ can be computed.

$$\begin{aligned}\Delta t &= N_{c1}T_c - N_{01}T_0 \\ &= \left(\frac{N_{c1}N_0}{N_c} - N_{01}\right)T_0\end{aligned}\quad (3)$$

Because the gate time 1 and gate time 2 start at same time, and stop at very close two different times, the frequency stability of $f_c(t)$ almost does not influence the measuring accuracy. It is the frequency fluctuation of the common oscillator in the time interval of not synchronized two finishing gate times that influences measuring accuracy. If the phase fluctuations of the common oscillator are small during this interval as compared to the phase fluctuations between $f_1(t)$ and $f_2(t)$ over a full gate time 2, the noise of the common oscillator is insignificant in the measurement noise error budget, which means in most cases the noise of the common oscillator can be worse than that of either $f_1(t)$ or $f_2(t)$ and still not contribute significantly. The common oscillator $f_c(t)$ is used to generate the suitable greatest common factor frequency and to help to accomplish the high accurate measurement. We only demand its frequency range, but its practical frequency and long term frequency fluctuation do not influence the measurement. The integral section (10 MHz) of the common oscillator $f_c(t)$ is the multiples of the compared frequency. In every T_{minc} period there are many regular phase change which is from small to large or from large to small. It is favourable to the "phase coincidence" detection circuit. Because in this case, it is the stability of "phase coincidence" detection circuit that decides the measuring accuracy. The circuit discriminability is not so important, and it is lower than the circuit stability.

This device can be used in a very wide frequency range, in the comparison of the integral frequency standards it can get very high measuring precision and accuracy. When it is used in the the comparison of 5 MHz or 10 MHz frequency standard, the better than 10 ps measuring precision can be obtained. In the device there are not any frequency transformation circuits or non-linear circuits. Therefore, it is very simple. This new method and instrument can be used widely in the time-frequency measurements.

References:

- [1.] Wei Zhou "The Greatest Common Factor Frequency and Its Application in the Accurate Measurement of Periodic Signals" 1992 IEEE Frequency Control Symposium, May, 1992
- [2.] Wei Zhou "A New Principle of Linear Phase Comparison — Irregular Phase Discrimination" 18th Annual PTTI Applications and Planning Meeting, Dec., 1986
- [3.] D.W.Allan, Herman Daams "Picosecond Time Difference Measurement System" 29th Annual Symposium on Frequency Control, pp.404 - 411, 1975

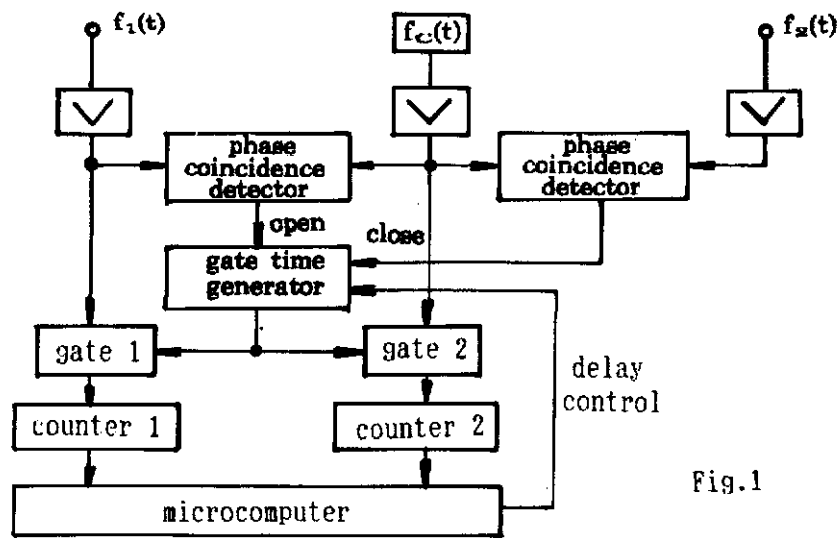

Fig.1

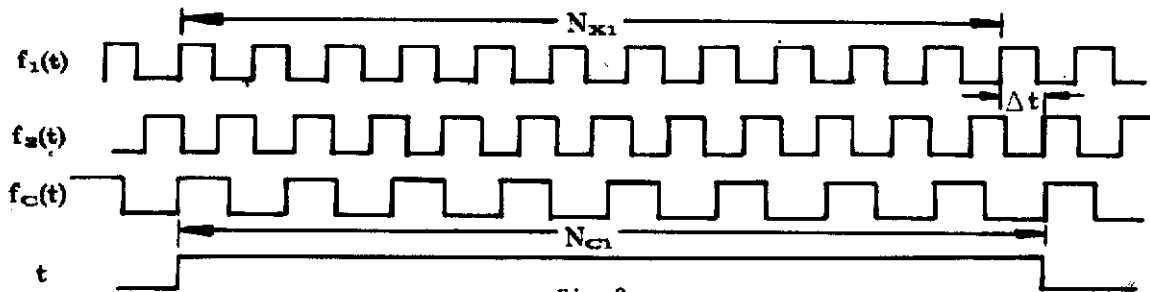

Fig.2

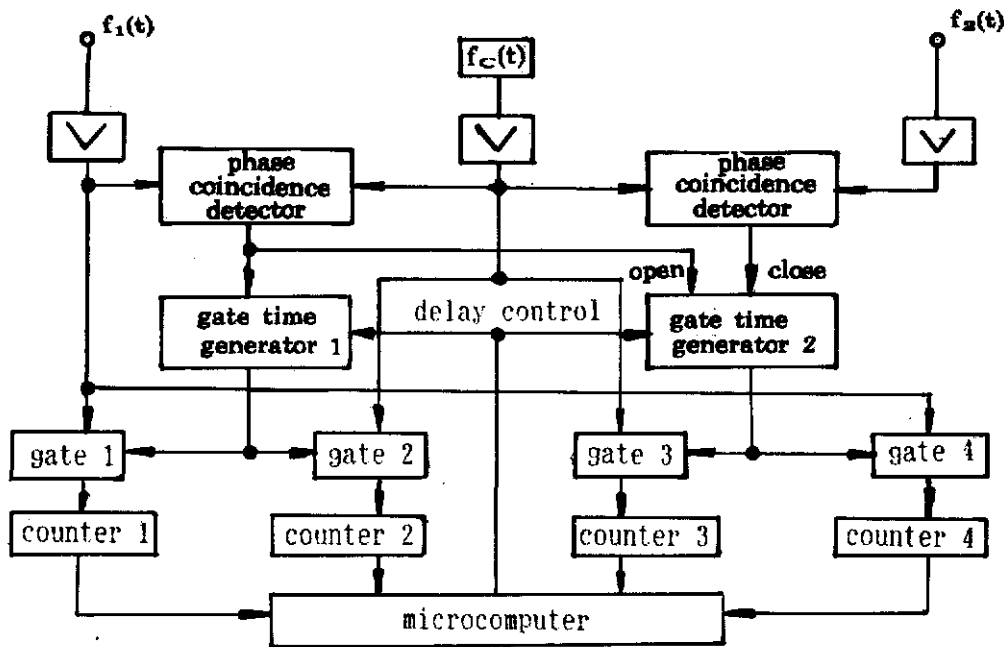

Fig.3