

REPORT DOCUMENTATION PAGEForm Approved
OMB NO. 0704-0188

Public Reporting burden for this collection of information is estimated to average 1 hour per response, including the time for reviewing instructions, searching existing data sources, gathering and maintaining the data needed, and completing and reviewing the collection of information. Send comment regarding this burden estimates or any other aspect of this collection of information, including suggestions for reducing this burden, to Washington Headquarters Services, Directorate for information Operations and Reports, 1215 Jefferson Davis Highway, Suite 1204, Arlington, VA 22202-4302, and to the Office of Management and Budget, Paperwork Reduction Project (0704-0188,) Washington, DC 20503.

1. AGENCY USE ONLY (Leave Blank)		2. REPORT DATE June 30, 2008	3. REPORT TYPE AND DATES COVERED 9/1/2007 to 5/31/2008	
4. TITLE AND SUBTITLE Development of an implantable optical neuroprosthetic: System intergration and testing.			5. FUNDING NUMBERS W911NF-07-1-0597	
6. AUTHOR(S) Vincent A. Pieribone, Ph.D. and Eugenio Culurciello, Ph.D.				
7. PERFORMING ORGANIZATION NAME(S) AND ADDRESS(ES) The John B. Pierce Lab. -290 Congress Avenue, New Haven, C T 06519 Yale University - 51 Prospect Street, New Haven CT 06520			8. PERFORMING ORGANIZATION REPORT NUMBER	
9. SPONSORING / MONITORING AGENCY NAME(S) AND ADDRESS(ES) U. S. Army Research Office P.O. Box 12211 Research Triangle Park, NC 27709-2211			10. SPONSORING / MONITORING AGENCY REPORT NUMBER 53393.1-LS-II	
11. SUPPLEMENTARY NOTES The views, opinions and/or findings contained in this report are those of the author(s) and should not be construed as an official Department of the Army position, policy or decision, unless so designated by other documentation.				
12 a. DISTRIBUTION / AVAILABILITY STATEMENT Approved for public release; distribution unlimited.			12 b. DISTRIBUTION CODE	
13. ABSTRACT (Maximum 200 words) This report contains the final progress report of the project entitled "Development of an implantable optical neuroprosthetic: System integration and testing." We have completed all goals set out in the application. I. We have redesigned and build the microscope body to be lighter weight. II. We designed and build the mounting hardware for attaching the microscope tot he head of a rodent. III. We have designed and build the camera head with associated PC boards to house and power the imaging chip. IV. We have redesigned, built and tested a new imaging chip based in silicon and sapphire. The results of this work is presented.				
14. SUBJECT TERMS Neuroprosthetic, fluorescent microscope, voltage dye imaging, nervous system, activity monitoring, CNS			15. NUMBER OF PAGES	
			16. PRICE CODE	
17. SECURITY CLASSIFICATION OR REPORT UNCLASSIFIED	18. SECURITY CLASSIFICATION ON THIS PAGE UNCLASSIFIED	19. SECURITY CLASSIFICATION OF ABSTRACT UNCLASSIFIED	20. LIMITATION OF ABSTRACT UL	

NSN 7540-01-280-5500

Standard Form 298 (Rev.2-89)
Prescribed by ANSI Std. Z39-18
298-102

Enclosure 1

REPORT DOCUMENTATION PAGE (SF298)
(Continuation Sheet)

- (1) List of papers submitted or published under ARO sponsorship **during this reporting period**. List the papers, including journal references, in the following categories:
 - (a) Manuscripts submitted, but not published - None
 - (b) Papers published in peer-reviewed journals - None
 - (c) Papers published in non-peer-reviewed journals or in conference proceedings - 1
 - (d) Papers presented at meetings, but not published in conference proceedings - None
- (2) Demographic Data **for this Reporting Period**:
 - (a) Number of Manuscripts submitted during this reporting period - None
 - (b) Number of Peer Reviewed Papers submitted during this reporting period - None
 - (c) Number of Non-Peer Reviewed Papers submitted during this reporting period - None
 - (d) Number of Presented but not Published Papers submitted during this reporting period - None
- (3) Demographic Data **for the life of this agreement**:
 - (a) Number of Scientists Supported by this agreement (decimals are allowed) - 2
 - (b) Number of Inventions resulting from this agreement - None
 - (c) Number of PhD(s) awarded as a result of this agreement - None
 - (d) Number of Bachelor Degrees awarded as a result of this agreement - None
 - (e) Number of Patents Submitted as a result of this agreement - None
 - (f) Number of Patents Awarded as a result of this agreement - None
 - (g) Number of Grad Students supported by this agreement - 1
 - (h) Number of FTE Grad Students supported by this agreement - None
 - (i) Number of Post Doctorates supported by this agreement - None
 - (j) Number of FTE Post Doctorates supported by this agreement - None
 - (k) Number of Faculty supported by this agreement - None
 - (l) Number of Other Staff supported by this agreement - None
 - (m) Number of Undergrads supported by this agreement - None
 - (n) Number of Master Degrees awarded as a result of this agreement - None
- (4) Student Metrics for graduating undergraduates funded by this agreement:
 - (a) Number of undergraduates funded by your agreement during this reporting period. - None
 - (b) Number of undergraduate funded by your agreement, who graduated during this period. - None
 - (c) Number of undergraduates funded by your agreement, who graduated during this period with a degree in a science, mathematics, engineering, or technology field. - None
 - (d) Number of undergraduates funded by your agreement, who graduated during this period and will continue to pursue a graduate or Ph.D degree in a science, mathematics, engineering, or technology field. - None
 - (e) Number of undergraduates funded by your agreement, who graduated during this period and intend to work for the Defense Department. - None
 - (f) Number of undergraduates graduating during this period, who achieved at least a 3.5 GPA based on a scale with a maximum of a 4.0 GPA. (Convert GPAs on any other scale to be an equivalent value on a 4.0 scale.) - None
 - (g) Number of undergraduates working on your agreement, who graduated during this period and were funded by a DoD funded Center of Excellence for Education, Research or Engineering. - None
 - (h) Number of undergraduates funded by your agreement, who graduated during this period and will receive a scholarship or fellowship for further studies in a science, mathematics, engineering or technology field. - None
- (5) "Report of inventions" - None
- (6) "Scientific progress and accomplishments" (see below)
- (7) "Technology transfer" -None

REPORT OF INVENTIONS AND SUBCONTRACTS
(Pursuant to "Patent Rights" Contract Clause) (See Instructions on back)

Form Approved
 OMB No. 5000-0095
 Expires Jan 31, 2008

The public reporting burden for this collection of information is estimated to average 1 hour per response, including the time for reviewing instructions, searching existing data sources, gathering and maintaining the data needed, and completing and reviewing the collection of information. Send comments regarding this burden estimate or any other aspect of this collection of information, including suggestions for reducing the burden, to the Department of Defense, Executive Service Directorate (9000-00095). Respondents should be aware that notwithstanding any other provision of law, no person shall be subject to any penalty for failing to comply with a collection of information if it does not display a currently valid OMB control number.

PLEASE DO NOT RETURN YOUR COMPLETED FORM TO THE ABOVE ORGANIZATION. RETURN COMPLETED FORM TO THE CONTRACTING OFFICER.

1.a. NAME OF CONTRACTOR/SUBCONTRACTOR The John B. Pierce Laboratory, Inc.	c. CONTRACT NUMBER Same	2.a. NAME OF GOVERNMENT PRIME CONTRACTOR Same	c. CONTRACT NUMBER W911NF-07-1-0597	3. TYPE OF REPORT (X one) a. INTERIM <input checked="" type="checkbox"/> b. FINAL
b. ADDRESS (Include ZIP Code) 290 Congress Avenue New Haven CT, 06519	d. AWARD DATE (YYYYMMDD) 09/01/2007	b. ADDRESS (Include ZIP Code) Same	d. AWARD DATE (YYYYMMDD) 20070901	4. REPORTING PERIOD (YYYYMMDD) a. FROM 09/01/2007 b. TO 05/31/2008

SECTION I - SUBJECT INVENTIONS

5. "SUBJECT INVENTIONS" REQUIRED TO BE REPORTED BY CONTRACTOR/SUBCONTRACTOR (If "None," so state)	NAME(S) OF INVENTOR(S) (Last, First, Middle Initial)	TITLE OF INVENTION(S)	DISCLOSURE NUMBER, PATENT APPLICATION SERIAL NUMBER OR PATENT NUMBER	ELECTION TO FILE PATENT APPLICATIONS (X)				CONFIRMATORY INSTRUMENT OR ASSIGNMENT FORWARDED TO CONTRACTING OFFICER (X)	
				(1) UNITED STATES		(2) FOREIGN			
a.	a.	b.	c.	(a) YES	(b) NO	(a) YES	(b) NO	(a) YES	(b) NO
None	None	None	None						

1. EMPLOYER OF INVENTOR(S) NOT EMPLOYED BY CONTRACTOR/SUBCONTRACTOR

(1) (a) NAME OF INVENTOR (Last, First, Middle Initial)	(2) (a) NAME OF INVENTOR (Last, First, Middle Initial)	(1) TITLE OF INVENTION	(2) FOREIGN COUNTRIES IN WHICH A PATENT APPLICATION WILL BE FILED
NA	NA	NA	NA

SECTION II - SUBCONTRACTS (Containing a "Patent Rights" clause)

6. SUBCONTRACTS AWARDED BY CONTRACTOR/SUBCONTRACTOR (If "None," so state)					
NAME OF SUBCONTRACTOR(S)	ADDRESS (Include ZIP Code)	SUBCONTRACT NUMBER(S)	FAR "PATENT RIGHTS"		DESCRIPTION OF WORK TO BE PERFORMED UNDER SUBCONTRACT(S)
			(1) CLAUSE NUMBER	(2) DATE (YYYYMM)	
a.	b.	c.	d.	e.	f.
None	None	None	None	None	None

SECTION III - CERTIFICATION

7. CERTIFICATION OF REPORT BY CONTRACTOR/SUBCONTRACTOR (Not required if: (X as appropriate))

I certify that the reporting party has procedures for prompt identification and timely disclosure of "Subject Inventions," that such procedures have been followed and that all "Subject Inventions" have been reported.

a. NAME OF AUTHORIZED CONTRACTOR/SUBCONTRACTOR OFFICIAL (Last, First, Middle Initial) Jordan Shapiro	b. TITLE Associate Director	c. SIGNATURE 	d. DATE SIGNED 7/7/08
--	---------------------------------------	--	---------------------------------

c. Final Progress Report

(1) Forward - None

(2) Table of Contents - None

(3) List of Appendixes - None

(4) Statement of problem studied - Continued development of an optical neuroprosthetic.

(5) Summary of the most important results

I. Redesign of the microscope housing, head attachment ring and objective lens.

In order to bring the microscope closer to functionality we have reduce its size and weight by reducing the material used in the make the microscope housing (Version 3.0).

While still using a polyethylene material we redesigned the microscope housing to be more form fitting to the internal elements, reducing the mass of plastic needed (Figure 1). In the new design we also included the necessary orifice size to include the larger (9 mm) low magnification objective lens (ThorLabs) we are currently using. Finally we have begun to develop the design of the head mounting ring (Figure 2). We have developed and built a three part system which includes a ring which is mounted over the craniotomy. This ring is made of stainless steel and is secured to the skull with cyanoacrylic. The ring is used to hold the dye

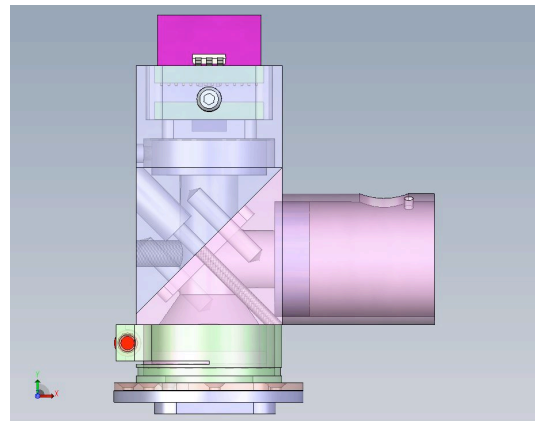
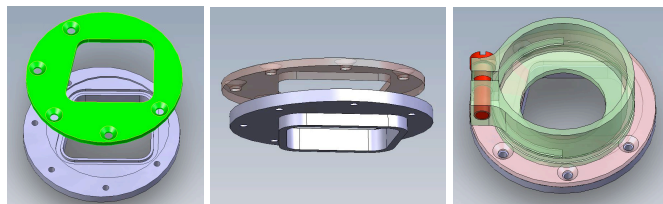

Figure 1: Microscope 3.0



for the staining step and then serves to form a well to hold ACSF once the staining is complete. The second part of the device is a coverslip (green structure in center pan of Figure 2) within a groove in the head mount. This cover is

Figure 2: Mounting plate

secured to the head ring with a series of tiny (000) screws. Once the mounting plate/ ring and cover are secured to the head, the microscope is lowered down with a mounting ring and attached to the animals head via dental cement. The microscope can then be removed from the pressure fit ring in between experiments.

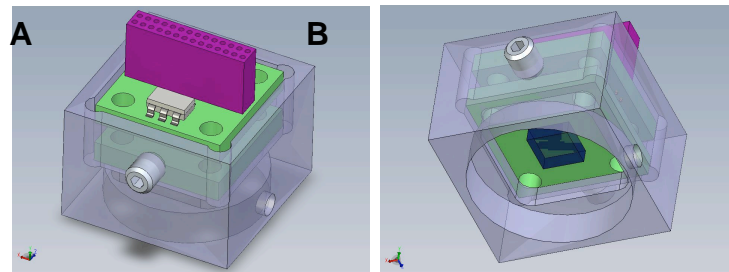

Figure 3: Camera

II. Design and built the camera housing and PC board. With this version of the microscope (3.0) we have begun to integrate the camera and imaging chip into the microscope. We have designed and constructed a camera housing for the imaging chip we have

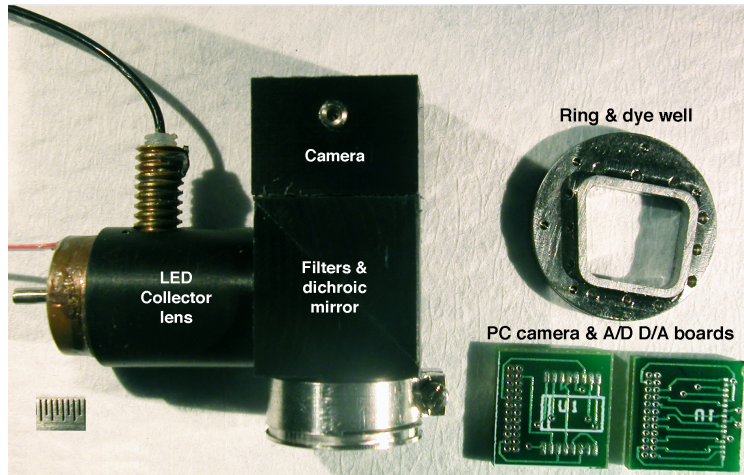

Figure 4: Microscope 3.0
to the top of the microscope.

developed (chip described below). This housing is small, light weight and includes two PC boards, which hold the chip and associated electronics (Figure 3 and 4). The upper board contains the A/D and D/A chips necessary to run the chip. On the upper board is an Omnetics connector (32 pins) to handle I/O for the camera (Violet structure in Figure 3A) and the imaging chip is mounted on the bottom face of the lower board (Purple structure in Figure 3B). The camera attaches by pressure fit

III. Redesigned and built the imaging chip using silicon on insulator technology.

The original design of imaging chips 1.0 and 2.0 used silicon on sapphire technology. The electrical design and circuitry of those chips were functional and meet specifications sampling at the desired rate. However, the spectral sensitivity of the chip was decidedly blue shifted with little sensitivity in the red. This was an unfortunate and wholly unexpected characteristic of this novel semiconductor material. For version 3.0 we chose the standard semiconductor material silicon and used the same differential imaging design of chips versions 1.0- 2.0 (Figure 5). We have just received the new chip and are now evaluating it. Currently it has all the characteristics we sought in an imaging chip for use in this microscope and has met all design characteristics. The chip's energy usage is extremely low (< 5 mW) and it has a high signal-to-noise ratio at

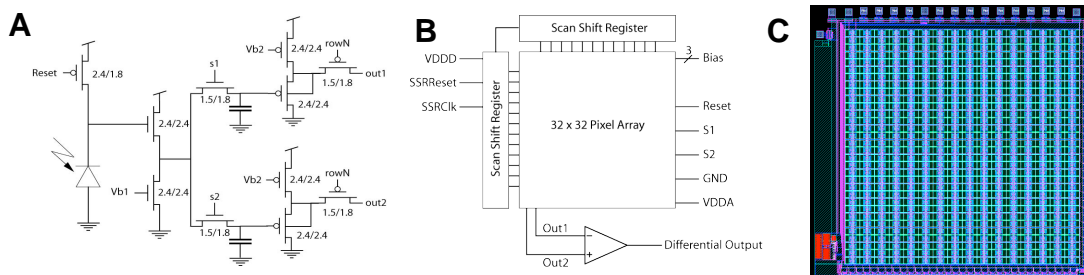

Figure 5: CMOS imaging chip. A) The pixel used in our design. Each pixel contains two storage capacitors that are used to store subsequent frame values and perform intensity difference computation. The photodetector area is $75\ \mu\text{m} \times 75\ \mu\text{m}$. B) Our system is composed of 32×32 pixel array. The scan shift registers are used to address each pixel. A global differential amplifier subtracts two subsequent pixel values. The sensor can also report intensity frames (no subtraction). This image sensor is fabricated in a bulk CMOS $0.5\ \mu\text{m}$ process. C) CAD drawing of the 32×32 CMOS imager chip as delivered to the foundry.

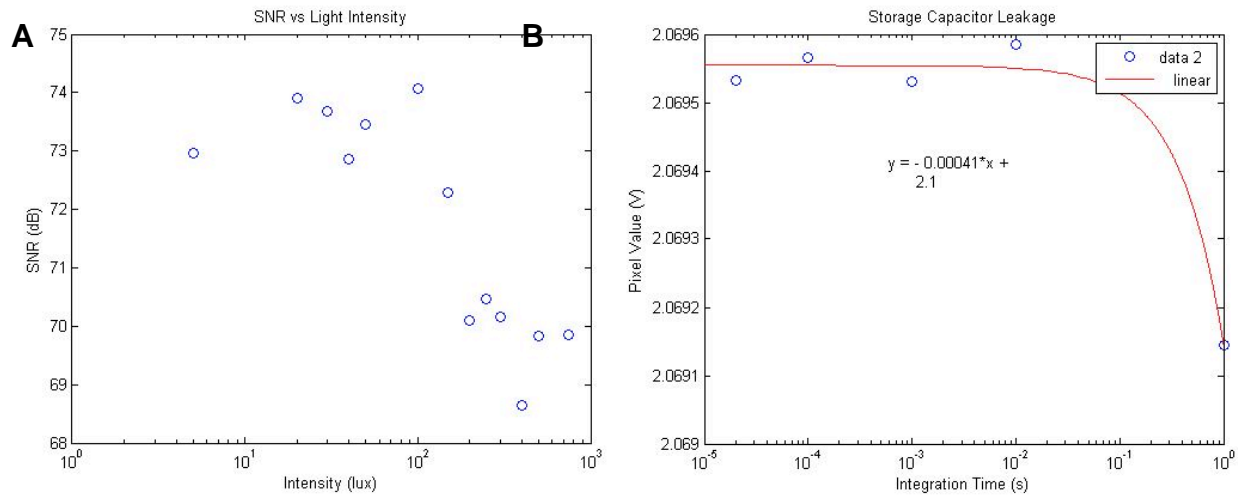

Figure 6: Imaging chip noise and holding capacitor leak characteristics

low light (70-75 dB at various light intensities; see Figure 6A). We were hoping for SNR of 55 to 72 dB the large immobile RedShirtImaging, LLC NeuroCCD has a SNR of 85 dB. We are well within the design specifications at low light we sought. This shows the leakage of our storage capacitor (used for frame differencing mode). The storage capacitor leaks 410 μV per second, which means at 1000 fps (1 ms integration time), it should leak 410 nV, well within our noise levels (Figure 6B).

We next collected images from the chip using the normal (Figure 7A) and on-chip frame subtraction mode Figure 7B). Image collection was performed using new Windows-based imaging software developed for the project that allows us to interface with the chip directly using a USB 2.0 board. We captured an image of a hand with the

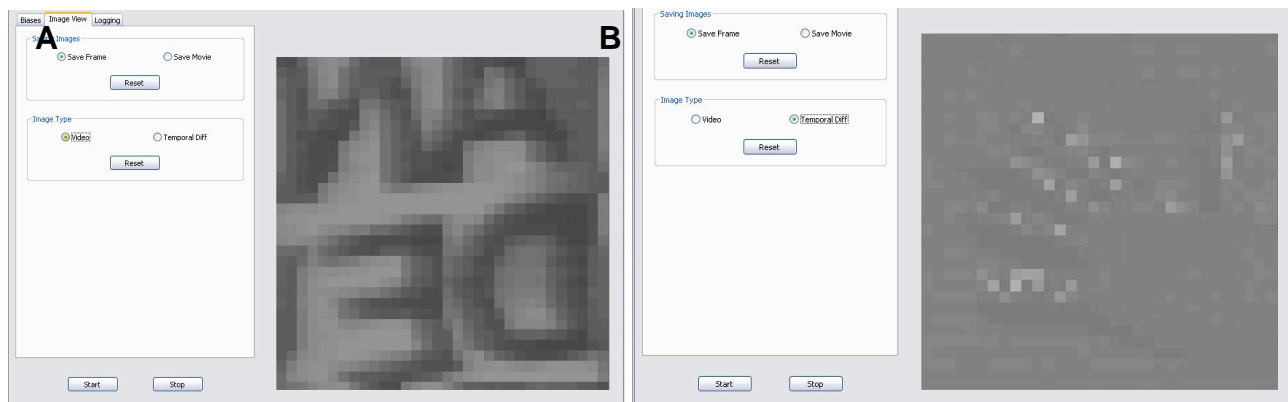

Figure 7: Images from new VSDI chip

fingers moving rapidly and the camera produces the difference image of only the movement. This interimage subtraction is the novel design characteristic of this chip and is functioning as designed.