



**NAVAL
POSTGRADUATE
SCHOOL**

MONTEREY, CALIFORNIA

THESIS

**AN EXAMINATION OF THE MH-60S COMMON COCKPIT
FROM A DESIGN METHODOLOGY AND ACQUISITIONS
STANDPOINT**

by

Peter A. Corrao

June 2009

Thesis Co-Advisors: Rudy Darken
Anthony Ciavarelli

Approved for public release; distribution is unlimited

THIS PAGE INTENTIONALLY LEFT BLANK

| REPORT DOCUMENTATION PAGE | | | Form Approved OMB No. 0704-0188 | |
|--|--|---|---|--|
| Public reporting burden for this collection of information is estimated to average 1 hour per response, including the time for reviewing instruction, searching existing data sources, gathering and maintaining the data needed, and completing and reviewing the collection of information. Send comments regarding this burden estimate or any other aspect of this collection of information, including suggestions for reducing this burden, to Washington headquarters Services, Directorate for Information Operations and Reports, 1215 Jefferson Davis Highway, Suite 1204, Arlington, VA 22202-4302, and to the Office of Management and Budget, Paperwork Reduction Project (0704-0188) Washington DC 20503. | | | | |
| 1. AGENCY USE ONLY (Leave blank) | | 2. REPORT DATE June 2009 | 3. REPORT TYPE AND DATES COVERED Master's Thesis | |
| 4. TITLE AND SUBTITLE An Examination of the MH-60S Common Cockpit from a Design Methodology and Acquisitions Standpoint | | | 5. FUNDING NUMBERS | |
| 6. AUTHOR(S) Peter A. Corrao | | | | |
| 7. PERFORMING ORGANIZATION NAME(S) AND ADDRESS(ES) Naval Postgraduate School Monterey, CA 93943-5000 | | | 8. PERFORMING ORGANIZATION REPORT NUMBER | |
| 9. SPONSORING /MONITORING AGENCY NAME(S) AND ADDRESS(ES) N/A | | | 10. SPONSORING/MONITORING AGENCY REPORT NUMBER | |
| 11. SUPPLEMENTARY NOTES The views expressed in this thesis are those of the author and do not reflect the official policy or position of the Department of Defense or the U.S. Government. | | | | |
| 12a. DISTRIBUTION / AVAILABILITY STATEMENT Approved for public release; distribution is unlimited | | | 12b. DISTRIBUTION CODE | |
| 13. ABSTRACT (maximum 200 words) Over the last two decades, cockpits have migrated from the traditional analog gauges of moving dials to computer displays representing an assortment of flight data. To keep in stride with this modernization trend, the U.S. Navy determined that the newest rotary-wing fleet aircraft, the MH-60S and MH-60R, would incorporate these advanced cockpit designs. This program was named <i>Common Cockpit</i> . Using structured interviews with current Navy MH-60S pilots, and analysis of system design models; it was determined that the MH-60 glass cockpit has fundamental flaws in cockpit design and usability. One major issue identified is the omission of a fully integrated moving map. The lack of a moving map is a serious issue because many of the MH-60 missions require precise navigation. The Navy pilots interviewed indicated that lack of a moving map makes mission task performance difficult and could threaten safety. It is argued here that a <i>user-centered</i> design methodology would have given ample consideration to including the moving map and would have produced a more effective and usable cockpit design. Recommendations are made to improve design methodology by using Crew-Centered Design methods. Recommendations are made regarding modification of existing Common Cockpit acquisitions procedures needed to produce a better product for the fleet. | | | | |
| 14. SUBJECT TERMS Common Cockpit, MH-60S Knighthawk, Crew-Centered Design Philosophy, Systems Engineering Cockpit Design Methodology, Human Computer Interface Design Methodology | | | 15. NUMBER OF PAGES 137 | |
| | | | 16. PRICE CODE | |
| 17. SECURITY CLASSIFICATION OF REPORT Unclassified | 18. SECURITY CLASSIFICATION OF THIS PAGE Unclassified | 19. SECURITY CLASSIFICATION OF ABSTRACT Unclassified | 20. LIMITATION OF ABSTRACT UU | |

THIS PAGE INTENTIONALLY LEFT BLANK

Approved for public release; distribution is unlimited

**AN EXAMINATION OF THE MH-60S COMMON COCKPIT FROM A DESIGN
METHODOLOGY AND ACQUISITIONS STANDPOINT**

Peter A. Corrao
Commander, United States Navy
B.S., United States Naval Academy, 1993

Submitted in partial fulfillment of the
requirements for the degree of

MASTER OF SCIENCE IN COMPUTER SCIENCE

from the

**NAVAL POSTGRADUATE SCHOOL
June 2009**

Author: Peter A. Corrao

Approved by: Dr. Rudy Darken
Co-Advisor

Dr. Anthony Ciavarelli
Co-Advisor

Dr. Peter Denning
Chairman, Department of Computer Science

THIS PAGE INTENTIONALLY LEFT BLANK

ABSTRACT

Over the last two decades, cockpits have migrated from the traditional analog gauges of moving dials to computer displays representing an assortment of flight data. To keep in stride with this modernization trend, the U.S. Navy determined that the newest rotary-wing fleet aircraft, the MH-60S and MH-60R, would incorporate these advanced cockpit designs. This program was named *Common Cockpit*. Using structured interviews with current Navy MH-60S pilots, and analysis of system design models; it was determined that the MH-60 glass cockpit has fundamental flaws in cockpit design and usability. One major issue identified is the omission of a fully integrated moving map. The lack of a moving map is a serious issue because many of the MH-60 missions require precise navigation. The Navy pilots interviewed indicated that lack of a moving map makes mission task performance difficult and could threaten safety. It is argued here that a *user-centered* design methodology would have given ample consideration to including the moving map and would have produced a more effective and usable cockpit design. Recommendations are made to improve design methodology by using Crew-Centered Design methods. Recommendations are made regarding modification of existing Common Cockpit acquisitions procedures needed to produce a better product for the fleet.

THIS PAGE INTENTIONALLY LEFT BLANK

TABLE OF CONTENTS

| | | |
|------|---|----|
| I. | INTRODUCTION | 1 |
| A. | PURPOSE | 1 |
| B. | BACKGROUND | 1 |
| C. | PROBLEM DEFINITION | 3 |
| II. | A REVIEW OF THE MH-60S AND COMMON COCKPIT IN RELATION TO THE ACQUISITIONS PROCESS | 5 |
| A. | COMPUTER EVOLUTION AND COCKPIT INTEGRATION | 5 |
| B. | HELICOPTERS AT SEA | 5 |
| C. | MH-60S PROGRAM | 7 |
| 1. | General Description | 7 |
| 2. | Program History | 8 |
| D. | THE COMMON COCKPIT | 15 |
| 1. | History | 15 |
| 2. | Description | 17 |
| III. | INTERVIEW METHODOLOGY | 21 |
| A. | INTERVIEW SUBJECTS AND PROCEDURES | 21 |
| B. | INTERVIEW METHODOLOGY RATIONAL | 22 |
| IV. | INTERVIEW RESULTS AND DISCUSSION | 27 |
| A. | INTERVIEW RESULTS SUMMARY | 27 |
| B. | GENERAL INTERVIEW DISCUSSION | 28 |
| C. | SPECIFIC DISCUSSION ON MOVING MAPS | 29 |
| V. | MOVING MAPS AND THE COMMON COCKPIT DESIGN METHODOLOGY .. | 31 |
| A. | MOVING MAP RATIONAL | 31 |
| 1. | Moving Maps | 31 |
| 2. | Moving Map MH-60S Implementation | 32 |
| 3. | Lockheed Martin Cockpit Design Methodology ... | 34 |
| a. | <i>Lockheed Martin Process Guidance Series Systems Engineering: Human-Computer Interface Requirements (HCIRS) Overview</i> .. | 35 |
| b. | <i>Systems Engineering Process</i> | 35 |
| c. | <i>The Iterative Process</i> | 36 |
| 4. | Digital Map Kneebord (DMK) | 38 |
| a. | <i>Digital Map System</i> | 39 |
| b. | <i>Pilots Likes/Dislikes and Limitations of Heads-down Devices</i> | 42 |
| c. | <i>Planned Obsolesce of the DMK</i> | 45 |
| B. | DESIGN METHODOLOGY FLAWS AND A SUGGESTED ALTERNATE DESIGN METHODOLOGY | 46 |
| 1. | Crew Centered Design Philosophy | 48 |

| | | |
|---------------------------|---|-----|
| 2. | Recommended Changes to Lockheed Martin HCI Design Methodology Based on the CCD Philosophy | 51 |
| a. | <i>Use of Design Methodology Specifically Developed for Cockpit Design</i> | 51 |
| b. | <i>Cost Effectiveness Must be Evaluated from a Holistic Standpoint</i> | 53 |
| c. | <i>View the Cockpit as a Sum of Its Parts for Design Decisions</i> | 53 |
| d. | <i>Carefully Consider Incorporating Previous Designs</i> | 56 |
| VI. | CONCLUSIONS, RECOMMENDATIONS AND FURTHER STUDY | 59 |
| A. | CONCLUSION | 59 |
| B. | APPLYING CREW CENTERED DESIGN | 59 |
| 1. | Functional Requirements Evaluated | 61 |
| 2. | Mapping Options | 62 |
| a. | <i>Ego-referenced Frame</i> | 63 |
| b. | <i>World-referenced Frame</i> | 65 |
| 3. | 2D/3D Solution | 65 |
| a. | <i>2D Moving Map</i> | 66 |
| b. | <i>3D ERF FLIR</i> | 71 |
| 4. | Symbology and Color Scheme | 72 |
| C. | RECOMMENDATIONS | 73 |
| 1. | Common Cockpit Recommendations | 73 |
| 2. | Defense Acquisitions Recommendations | 74 |
| D. | FUTURE WORK | 76 |
| APPENDIX A: | INTERVIEW RESULTS SUMMARY | 79 |
| A. | SUMMARY STATISTICS | 79 |
| B. | QUESTION SUMMARIES | 79 |
| APPENDIX B: | RAW INTERVIEW DATA | 83 |
| LIST OF REFERENCES | | 111 |
| INITIAL DISTRIBUTION LIST | | 119 |

LIST OF FIGURES

| | | |
|------------|--|----|
| Figure 1. | CH-46D Sea Knight was eventually replaced by the MH-60S (From: [1])..... | 6 |
| Figure 2. | MH-60S Knighthawk doing VERTREP duties (From: [2])..... | 7 |
| Figure 3. | The Helo Master Plan (From: [3])..... | 9 |
| Figure 4. | Original Helo Master Plan (From: [4])..... | 13 |
| Figure 5. | Revised Helo Master Plan based on the CH-60 acquisition (From: [4])..... | 14 |
| Figure 6. | MH-60S Block I Common Cockpit (From: [5])..... | 18 |
| Figure 7. | PKI / FFK located in the lower consol area of the CC (From: [5])..... | 19 |
| Figure 8. | Lockheed Martin Human Computer Interface Requirements (HCIRS) contents (From: [6])..... | 36 |
| Figure 9. | Lockheed Martin eight step HCI design process (From: [6])..... | 37 |
| Figure 10. | DMS (From: [7])..... | 40 |
| Figure 11. | Current fleet DMK. Pen included for size reference only..... | 40 |
| Figure 12. | Current fleet DMK. Pen included for size reference only..... | 41 |
| Figure 13. | DMK Specifications (After: [8])..... | 42 |
| Figure 14. | Cost of design changes as a function of time (From: [9])..... | 46 |
| Figure 15. | Systems engineering iterative HCI design process (From [10])..... | 49 |
| Figure 16. | Inserting the Crew-Centered Design philosophy in to the traditional design methodology (From: [10], p. 9)..... | 50 |
| Figure 17. | The current navigation display of the CC (From: [11, Keys cockpit interface simulator])..... | 58 |
| Figure 18. | Egocentric, Exocentric perspective, and Exocentric Plan-view displays (From: [12])..... | 64 |
| Figure 19. | A progression of viewpoints from ERF to 2D planar view. Exocentric 2D side view is on the far right (After: [13])..... | 64 |

THIS PAGE INTENTIONALLY LEFT BLANK

LIST OF TABLES

| | | |
|----------|---|----|
| Table 1. | MH-60S Characteristics (From: [14])..... | 8 |
| Table 2. | Subject summary data..... | 22 |
| Table 3. | Mission experience among interview subjects. Subjects are often familiar with more than one mission area..... | 24 |
| Table 4. | In-person informal interview attributes (After: [15])..... | 25 |
| Table 5. | Interruption and distraction factors (From: [16])..... | 44 |

THIS PAGE INTENTIONALLY LEFT BLANK

LIST OF ACRONYMS AND ABBREVIATIONS

2D - Two Dimensional
3D - Three Dimensional
AMCM - Airborne Mine Counter Measures
ASW - Anti Submarine Warfare
CAAS - Common Avionics Architecture System
CC - Common Cockpit
CAN - Center for Naval Analysis
CCD - Crew Centered Design
CSAR - Combat Search and Rescue
DMK - Digital Map Kneeboard
DMLS - Digital Map Loading System
DoD - Department of Defense
DoDAF - Department of Defense Architecture Framework
ERF - Ego Referenced Framework
FAM - Familiarization Flight
FFK - Fixed Function Key
FLIR - Forward Looking Infrared
FMC - Flight Mission Computer
FRS - Fleet Replacement Squadron
GATM - Global Air Traffic Management
GOTS - Government Off The Shelf
HAC - Helicopter Aircraft Commander
HCI - Human Computer Interaction
HCU - Hand Control Unit
HSC - Helicopter Sea Combat
HUD - Heads Up Display
ICS - Internal Communications System
IRAD - Independent Research and Development
LAMPS - Light Airborne Multipurpose System
LOG - Logistics

MC - Mission Computer
MEDEVAC - Medical Evacuation
MFD - Multi-Function Display
MLR - Medium List Replacement
MSII - Milestone II
NAVAIR - Naval Air Systems Command
NSW - Naval Special Warfare
NTDS - Naval Tactical Display Symbols
NVD - Night Vision Device
ORD - Operational Requirements Document
OSD - Office of the Secretary of Defense
PKI - Programmable Key Interface
R&D - Research and Development
SAR - Search and Rescue
SPECOPS - Special Operations
USN - United States Navy
USNR - United States Naval Reserve
VBSS - Visit, Board, Search and Seizure
VERTREP - Vertical Replenishment
WRF - World Referenced Framework

ACKNOWLEDGMENTS

I'd like to acknowledge several people who were instrumental to getting this thing put to bed.

Hats off to Dr. Jean-Francios D'Arcy and Christine Collins at Lockheed Martin, who were a wealth of both documentation and answers. Chris' information and recommendations were spot-on every time!

I'd like to offer a hearty salute to CDR Spencer Crispell, CDR Wade McConvey, LCDR Scott Stringer and especially CDR Mike Harman at NAVAIR for all the source documentation ranging from initial acquisitions items to technical information. Without support from NAVAIR, this vital information would be impossible to come by.

Of course, I'd like to thank Dr. Tony Ciavarelli and Dr. Rudy Darken, my advisors, for keeping me on the straight and narrow. Your input was always on target and kept it all relevant.

A big thanks to Janice Rivera and Pam Silva, my personal thesis formatters! Not once did they make fun of my poor grammar and complete disregard for proper punctuation. This is no small feat.

Last, and certainly not least, I'd like to thank my family: Noelle, Diana, and Alexandra. All those great promises about NPS being a great opportunity to spend time with the family were not even close! You guys weathered through my frequent absenteeism and always supported me 100%! I am truly blessed.

THIS PAGE INTENTIONALLY LEFT BLANK

I. INTRODUCTION

A. PURPOSE

This thesis will accomplish three fundamental tasks:

- Using structured interview methods, usability engineering techniques and the author's personal expertise, determine if there are any existing design or usability issues with the MH-60S Common Cockpit
- In regard to these existing design issues, review the methodology under which the design was created and recommend a different or modified methodology that would create a better design. Using this recommended design methodology, present a description of one potential design improvement.
- In the scope of the Common Cockpit acquisitions process, recommend changes to said process that would enable a better cockpit to be designed and acquired.

B. BACKGROUND

The author's first experience with piloting an aircraft came formally in the spring of 1994. It was at Whiting Field, Pensacola, Florida, where he was first introduced to the complexities and challenges of piloting an aircraft. Following the standard training track, he started with the basic single-engine turbo-prop T-34. Following the fleet helicopter replacement pipeline, he then flew the basic

helicopter trainer, the TH-57. Basic flight training was followed by training and operational missions in the fleet helicopter H-46D Seaknight, where he accrued almost 1,000 flight hours. This tour was followed by extensive experience in two more fleet aircraft: the H-3 Sea King helicopter and the twin-engine fixed-wing utility transport C-12B Huron. His most recent tour was in yet another fleet helicopter, the MH-60S Knighthawk.

Unique to the Knighthawk and a substantial departure from previous aircraft was the use of an all-digital "glass" cockpit. Simply put, the traditional analog dials, gauges and switches of the previous generation of aircraft have been replaced with four LCD monitors and a host of keypads and other more "computer interface" oriented input devices.

To the author, the potential of this transition was exciting. Having seen computers explosively grow in both functionality and usability since first being exposed to the Radio Shack TRS-80 and Commodore 64 in the mid-1980s, the author assumed that a 21st century cockpit must have the functionality of any top computing system and the usability of the sleekest operating system. He imagined a cockpit where the feel was more like the bridge of the Starship Enterprise than the cockpits of the previous generation of aircraft he had flown. The expectation was that everything was configurable, selectable, scalable, and absolutely user-friendly. Those lofty expectations were not quite met.

The author encountered a cockpit that did indeed have some of these features, but in many aspects seemed lacking. To the author and his fellow squadron pilots, there seemed to be something fundamentally lacking in the usability of

the cockpit itself. Too often, particularly with new pilots, the cockpit seemed a jumbled collection of buttons and computer menus. It was clear that usability had taken a back seat to functionality during design. How could this have happened in the Navy's newest cockpit?

Following his tour in the Knighthawk, the author opted to explore the science behind the computers that drove that cockpit. While studying Computer Science at the Naval Postgraduate School, he was exposed to the concepts of Human Computer Interfaces. Armed with knowledge, he arrived at the purpose of this thesis.

C. PROBLEM DEFINITION

Based on informal user interviews and personal experience, the MH-60S cockpit has fundamental user design and usability issues that potentially impact mission accomplishment. The question is thus: Will the use of a more Human Systems Integration (HSI) oriented design methodology, applied to the same functional requirements as outlined in MH-60S Operational Requirements Document (ORD), produce a more usable result?

Also, can this design methodology be applied throughout the acquisitions process in order to not only enhance cockpit usability but all human-machine usability?

THIS PAGE INTENTIONALLY LEFT BLANK

II. A REVIEW OF THE MH-60S AND COMMON COCKPIT IN RELATION TO THE ACQUISITIONS PROCESS

A. COMPUTER EVOLUTION AND COCKPIT INTEGRATION

The last 20 years of aircraft design and development has seen a revolution of sorts. As computers emerged from the large units, common in the 1950s, to the sleek, light and low-power units of today, they have also slowly made their way into the aircraft. Today's modern computer-integrated or "glass" cockpits almost resemble a computer work station more than a traditional cockpit.

B. HELICOPTERS AT SEA

Of military fleets in the world, the need to conduct sustained operations at sea is the backbone of power projection. In this effort of sustainment, logistics is the key. Fleet logistics is, of course, a little more complicated than traditional land logistics since everything has to be delivered to ships, which prefer to be at sea. One method of doing this is via a delivery technique called Vertical Replenishment (VERTREP). This supply delivery procedure involves transferring goods and people from one ship to another, shore to ship or ship to shore, by either attaching an external load to a helicopter or via an internal transfer. For years, this mission was filled by the versatile H-46D Sea Knight (Figure 1).



Figure 1. CH-46D Sea Knight was eventually replaced by the MH-60S (From: [1]).

Although the aircraft was initially intended as a logistics platform, as time progressed and the needs of the fleet became more varied, the Sea Knight's mission set expanded to include Search and Rescue (SAR), Visit Board Search and Seizure (VBSS) and some limited Special Operations (SPECOPS).

By the early 1990s, two things quickly became readily apparent to Navy planners: the Sea Knight was rapidly exceeding its life expectancy, and the continued growth of mission sets was pushing the limits of the airframe. It was time for a replacement. The answer came in the form of the Sikorsky MH-60S (Figure 2).



Figure 2. MH-60S Knighthawk doing VERTREP duties (From: [2]).

C. MH-60S PROGRAM

1. General Description

The MH-60S is an all-weather multi-mission helicopter built as an amalgam of UH-60 Blackhawk and SH-60 Seahawk components. First deployed in January 2003, the MH-60 Knighthawk is designed to conduct a varied mission suite including Airborne Mine Countermeasures (AMCM), Logistics (LOG) and a more aggressive mission known as Combat Search and Rescue (CSAR, also known as Armed Helo or AH) [14]. Characteristics are summarized in Table 1.

| Dimensions: | |
|----------------------------|--|
| Main Rotor Diameter | 16.36m |
| Tail Rotor Diameter | 3.35m |
| Overall Length With Rotors | 19.76m |
| Turning | |
| Height to Top of Turning | 5.13m |
| Tail Rotor | |
| Height to Top of Rotor | 3.76m |
| Head | |
| Length of Fuselage | 15.26m |
| Cabin Volume | 11.6m ³ |
| Engines: | |
| Type | 2 x GE T700-GE-401C turboshaft engines |
| Take-Off Rating | 1,260kW each |
| Performance: | |
| Maximum Cruise Speed | 263km/h |
| Never-Exceed Speed | 333km/h |

Table 1. MH-60S Characteristics (From: [14]).

2. Program History

The MH-60S was born out of a recognized need in the early 1990s to replace several aging helicopter platforms. By the end of the cold war, the Navy was operating eight types of helicopters [17]. All were specialized for different missions, including Vertical Replenishment (VERTREP) and logistics (LOG), Anti-submarine Warfare (ASW), Combat Search and Rescue (CSAR) and Naval Special Warfare (NSW) [4]. Of the fleet helicopters, the H-1N, H-3 and H-46 and HH-60H were either very near or approaching the end of their service lives [18].

Conventional naval rotary-wing aviation urban legend holds that around this time, seeing an opportunity to reduce operating costs and increase mission flexibility, the Navy

initiated a program that would pare down the existing diverse helicopter fleet to just two variants of the Sikorsky H-60 (Figure 3). As this section will chronicle, this simple interpretation of history is not quite the case.



Figure 3. The Helo Master Plan (From: [3]).

The CH-60, as the MH-60S was originally known, had its roots in the late 1980s and early 1990s discussions revolving around the Marine Corps vertical Medium Lift Replacement (MLR) project [19]. At the time, the Marine Corps was funding the development of the Boeing MV-22 medium lift tilt rotor to replace its aging CH-46E medium lift helicopter fleet. While Secretary of Defense under President George H.W. Bush, Mr. Dick Cheney attempted to

terminate the V-22 program due to cost overruns. His solution to the MLR was the Sikorsky CH-60 [19].

After a protracted battle, the Marine Corps eventually won and continued its plan to acquire the MV-22. Sikorsky, however, continued to shop its CH-60 to all four services [20]. In specific reference to the Navy portion of the Sikorsky proposal, *Inside the Army* writes:

As for the Navy, Sikorsky contends the service's fleet support helicopter assets "are aging and experiencing accelerated attrition." The Navy has some recapitalization plans in place -- such as an upgrade to its fleet of CH-46s and procurement of a new helicopter beginning in FY-98 -- but Sikorsky anticipates an upcoming cost and operational effectiveness analysis will "have difficulty dealing with the cost effectiveness" of them. [20]

Inside the Army continues:

Some observers theorize that the Sikorsky proposal is merely an effort to stave off a halt in the Black Hawk production line should the Office of the Secretary of Defense not give the Army additional money for Black Hawk procurement in FY-97. [20]

By 1996, Sikorsky had grown desperate to push the CH-60 multi-service program, or at the very least extend the manufacture of Army UH-60 Black Hawk program [21]. They felt their life depended on it:

There is trouble down the road [for Sikorsky], a company official said last week. "Without Black Hawk procurement, it would be difficult for Sikorsky to continue as a company." He added that Black Hawk procurement could total as much as \$1.1 billion over the next five years. "And right now Sea Hawk production has stopped and the CH-53 procurement is not significant," he

continued, "and there really is no future program except the [SH-60R] . . . so, no, there's not a lot of business right now for Sikorsky. The draft briefing charts prepared by the Program Analysis and Evaluation shop state flatly that the 'Cancellation of UH-60 buys may affect Sikorsky's survival, and has cost implications for the Army's RAH-66 Comanche.' [21]

The Army had originally planned to buy 36 Black Hawk helicopters per year during fiscal years 1998-2003 but had shifted these monies to other priorities [21].

This mess quickly drew in the Marine Corps again, this time in their effort to update the UH-1N. The original Marine plan was to update both the UH-1 and AH-1 to the N and W models, respectively. This upgrade would leverage an already existing training and supply system while upgrading the cockpits and engine/rotor combination [22]. The Office of the Secretary of Defense (OSD), headed by Mr. William Perry, however, wanted to keep the Sikorsky production lines open and continued to push the CH-60 as an alternative to the UH-1.

Angered by the Army's move to halt UH-60 Black Hawk production, the OSD drafted a plan to take the almost \$1 billion originally scheduled for the UH-60 and give it to the Navy or Marine Corps to fund the CH-60, a predominately Black Hawk variant. The Marines balked yet again, preferring to stick with their original upgrade plans for the Cobra and Huey [23].

The Navy, however, saw an opportunity to solve several of their helicopter problems with one solution. Starting in 1995, the Navy starting drafting the "Navy Helo Master Plan" (HMP)[4]. The HMP morphed out of a Center for Naval

Analysis (CNA) study that looked at the Navy's helicopter force structure and what would be required to transition to the future. The initial HMP roadmap didn't include the CH-60 (Figure 4) but, once word of a potential "free" Black Hawk variant was out, the plan was quickly revised (Figure 5). The H-60B/F airframe that was currently in use was not considered since that particular production line had already been shuttered. The replacement for the H-60B/F, named the MH-60R was also not considered since that production line wasn't scheduled to start running until early in first decade of 2000 and would do nothing to keep the Blackhawk line open. This move to "give" the Navy a "free" airframe virtually locked in the CH-60 as the helicopter of choice for the Navy since the entire Navy helicopter roadmap depended on it [24].

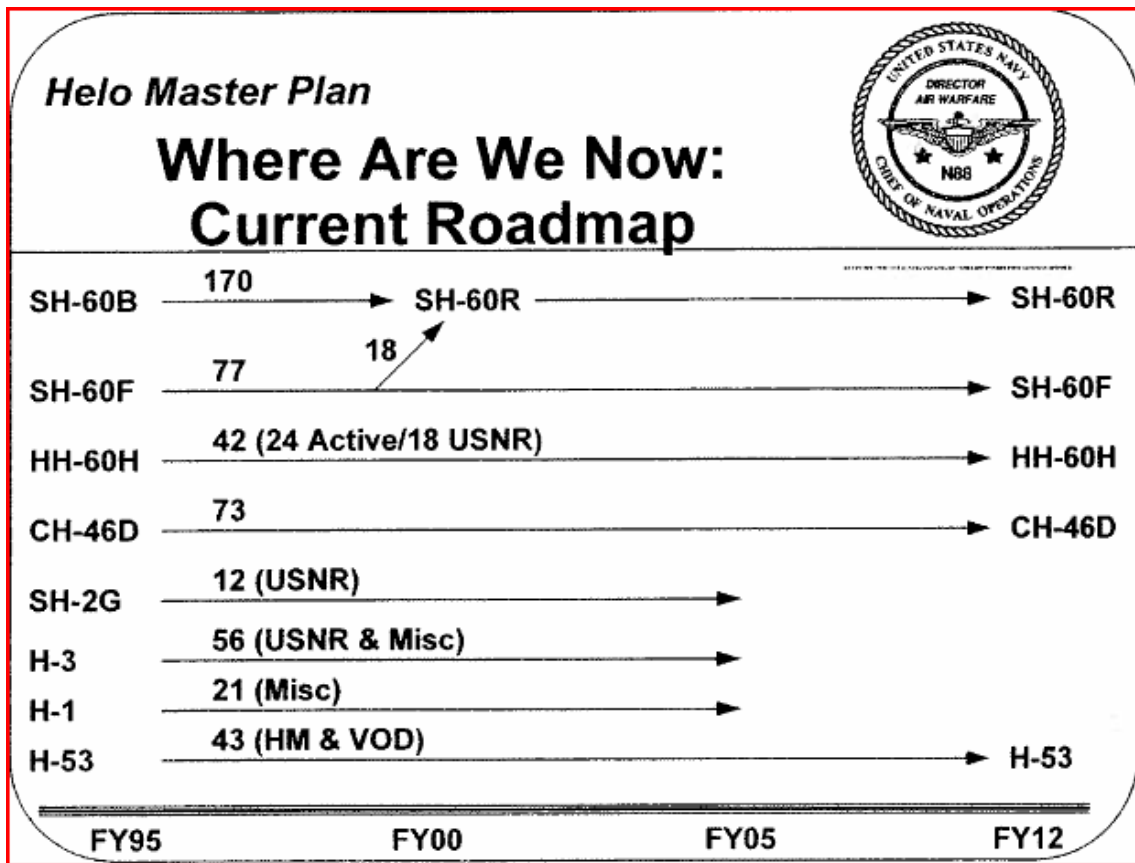

Figure 4. Original Helo Master Plan (From: [4]).

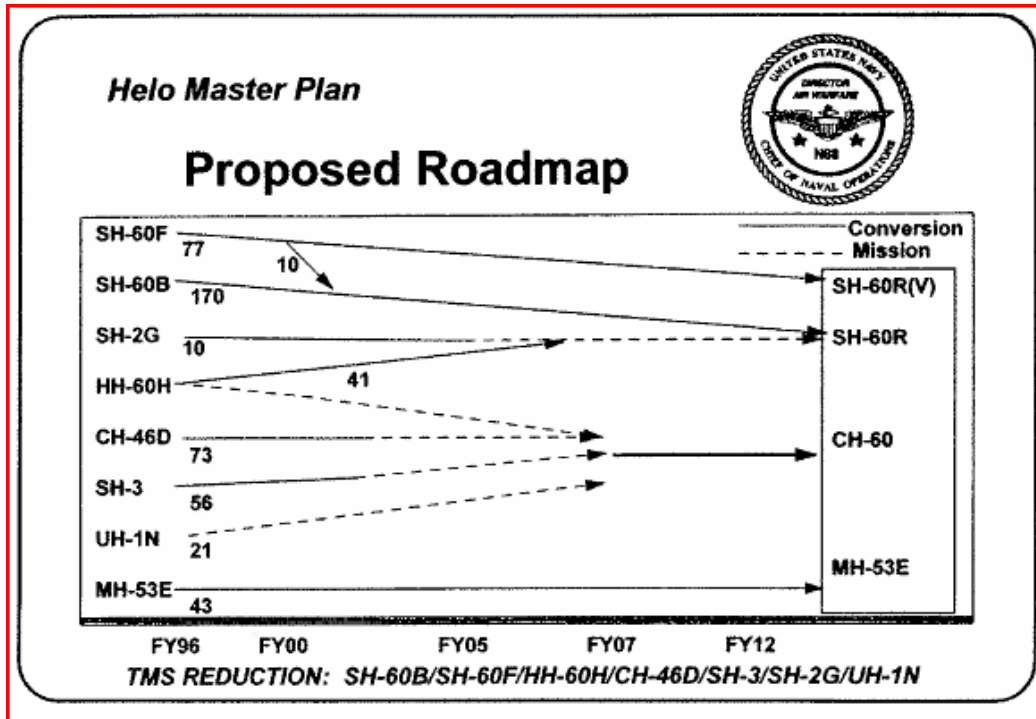

Figure 5. Revised Helo Master Plan based on the CH-60 acquisition (From: [4]).

The HMP momentum resulted in a sole source Request For Proposal (RFP) for Sikorsky being issued in 1996 [24]. In fiscal year (FY) 1997, Congress directed Sikorsky Aircraft (SAC) to produce a demonstration aircraft [25]. This Operational Assessment (OA) demonstrator was a combination of the existing UH-60L Blackhawk airframe with H-60 Seahawk components [26]. Between November 1997 and January 1998, a successful Operational Assessment (OA) directed by Commander, Operational Test and Evaluation Force (COTF) was conducted [25]. This success led to the program receiving a Mile Stone II (MSII) (Milestone B equivalent)/Low Rate Initial Production (LRIP) go-ahead decision in July 1998 and Sikorsky being named as the sole source contractor on October 6, 1998. The contract was under the existing U.S. Army Aviation & Missile Command, Redstone Arsenal as the

contracting activity [27]. It should be noted that during the OA, "Neither approved nor signature-ready ORD (Operational Requirements Document) or TEMP (Test and Evaluation Master Plan) documents were available during the November 1997-January 1998 OA period" [28, p. 2] and draft documents were used as a guideline.

Designated an Acquisitions Category IC (ACAT IC) program by the Under Secretary of Defense for Acquisition, Technology & Logistics (USD(AT&L)) in July of 1998 [25], the program quickly ramped up. The all new production CH-60S first flight followed in January 2000 [14], [29]. The CH-60S was quickly re-designated the MH-60S to reflect the multi-mission capability of the airframe [14]. Three distinct mission sets were designed in and called "blocks". Block I reflected the general logistics mission, block II was modified to conduct Airborne Mine Countermeasures (AMCM) and block III incorporated the more offense Armed Helo (AH) mission kits [7]. By FY 2008, 132 airframes had either been ordered or fielded to Navy squadrons. The current plans call for a total of 237 [14].

D. THE COMMON COCKPIT

1. History

As the new CH-60 started production and the planned MH-60R (scheduled for production in 2000 [21] firmed up, the Navy decided to make the technological leap to an all digital, or "glass," cockpit display for both the MH-60S and MH-60R helicopters. This cockpit, designed for use on both airframes to enhance commonality [29], was named the Common Cockpit (CC). At this point, the CC was notional and lacked

any specific ORD type document of its own. At this point the MH-60R was the more mature of the two programs and thus it can be concluded that initial efforts for the CC were applied toward MH-60R functional requirements.

Initially included as part of the MH-60S Operational Requirements Document (ORD) [30] as well as the MH-60R ORD, the CC was spun-off as an "845" contract prior to 2002 [31]. An 845 contract refers to "10 U.S.C. 2371, Section 845, Authority to Carry Out Certain Prototype Projects." [32] Per the OT Guide:

Other "Transactions" for prototype projects are acquisition instruments that generally are not subject to the federal laws and regulations governing procurement contracts. As such, they are not required to comply with the Federal Acquisition Regulation (FAR), its supplements, or laws that are limited in applicability to procurement contracts. [32, p. 8]

Due to its designation as an 845 program, funding, particularly Research and Development (R&D) costs, are difficult to define. According to [33], Lockheed Martin was awarded a \$423 million contract to produce common cockpits for the MH-60S and MH-60R. This amount, however, may not include R&D costs, since this is a production (APN-1) contract and usually does not include research and development costs. For certain, prior to the contract award, \$70.53 million had been spent, at least in part, on R&D [34]. Other R&D costs may be included in the Sierra and Romeo development costs but are not clearly defined [35].

CC requirements are also scattered throughout the Sierra and Romeo ORDs and hard to concisely determine. As an initially cobbled-together program, the CC currently

lacks a clearly defined requirements document such as the MH-60S ORD. As of this writing, however, there is a push to formalize these requirements [35], [36].

2. Description

The Common Cockpit (Figure 6) is made up of several components including Multi-Function Displays (MFD), Fixed-Function Keys (FFK) (Figure 7) and Programmable Key Interface (PKI).

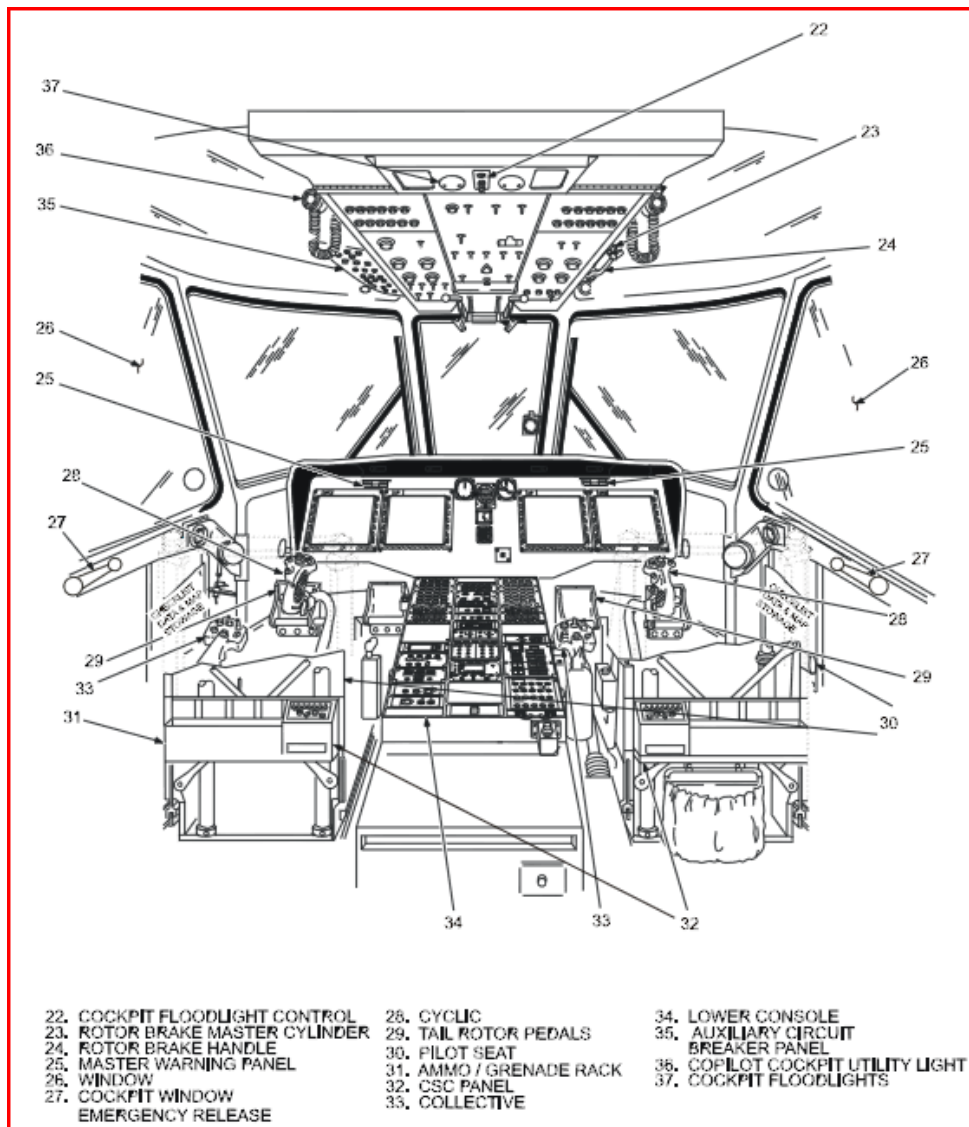

Figure 6. MH-60S Block I Common Cockpit (From: [5]).

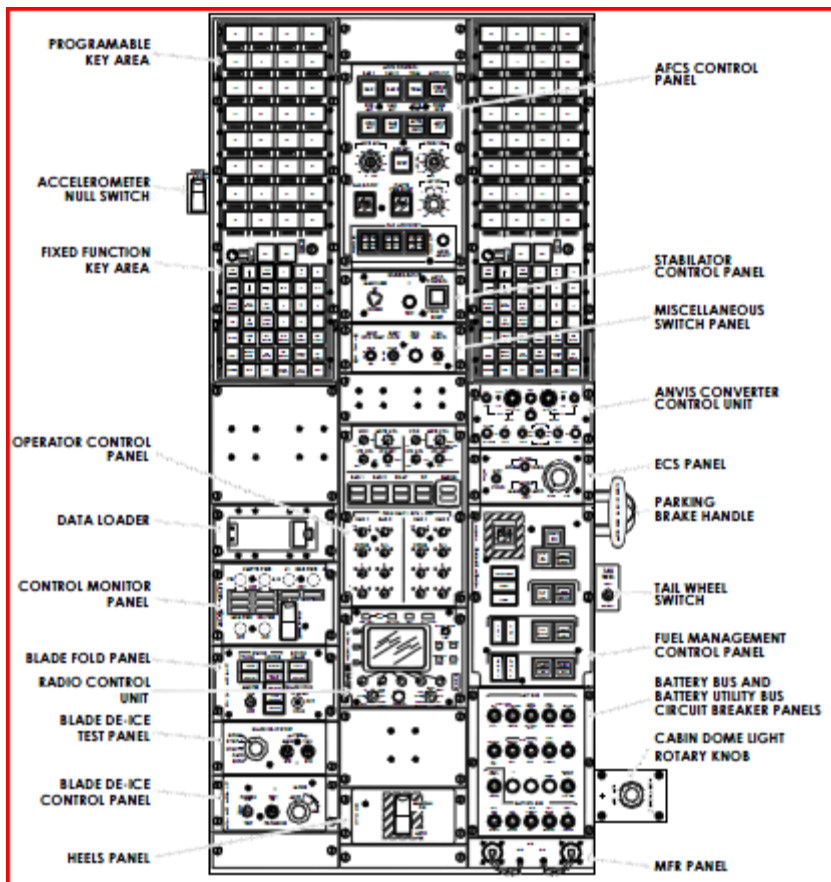

Figure 7. PKI / FFK located in the lower consol area of the CC (From: [5]).

According to [14]:

The CC includes four 8in x 10in active matrix liquid crystal displays and dual programmable operator keysets. The avionics includes dual flight management computers and an audio management computer. The navigation suite includes a Northrop Grumman (Litton) LN-100G dual embedded global positioning system and inertial navigation system.

THIS PAGE INTENTIONALLY LEFT BLANK

III. INTERVIEW METHODOLOGY

Based on an in-depth knowledge of the subjects by the author, himself an experienced U.S. Navy pilot, a structured interview method was chosen to obtain needed U.S. Navy Fleet pilot inputs on the MH-60 design. The interview method selected is based on several considerations as described in [15, p. 9] and elaborated below. Interview data is summarized in Appendix A. Raw interview data is found in Appendix B.

A. INTERVIEW SUBJECTS AND PROCEDURES

Nine subjects were interviewed over a three-day period from October 27, 2008, to October 29, 2008. Subjects were all pilots from the MH-60S West Coast Fleet Replacement Squadron, Helicopter Sea Combat Squadron 11 stationed at Naval Air Station, North Island, San Diego, California. Eight of the subjects were instructor pilots and one was a student pilot nearing the end of the training syllabus. Pilot experience is summarized in Table 2. Of nine subjects interviewed two were qualified Helicopter Aircraft Commander (HAC) in a different aircraft model. Table 2 summarizes subject flight hour and experience levels.

| Total Flight Hours | Total MH-60S Flight Hours | Qualified HAC in Different Aircraft |
|--------------------|---------------------------|-------------------------------------|
| 1200 | 30 | Yes |
| 1200 | 1000 | No |
| 1370 | 250 | Yes |
| 1300 | 1000 | No |
| 1450 | 1200 | No |
| 275 | 100 | No |
| 1550 | 1350 | No |
| 1250 | 1000 | No |
| 1300 | 900 | No |

Table 2. Subject summary data.

Interviews were conducted in a HSC-11 briefing room well known to all nine subjects. All interviews were conducted during normal working hours (0800-1500). Questions were formulated by the author based on his expert knowledge as an aviator and was tailored to efficiently capture not only subject facts, opinions, attitudes and answers but also the reasoning behind the answer. In short, the author based the interview questions on what he thought would make sense if he were in the subject's position. The complete Interview Summary in Appendix A and raw interview notes are found in Appendix B.

B. INTERVIEW METHODOLOGY RATIONAL

The primary interview consideration in regard to the subject pool was an attempt to get a somewhat representative picture from all fleet squadrons. There are currently seven squadrons flying the MH-60S. Three squadrons are located in San Diego, CA, three in Norfolk, VA, and one in Guam. Mission sets for each squadron vary depending on the deployment and are not equally distributed throughout the

squadrons. Thus a pilot of one squadron may encounter significant different operating conditions of another pilot in another squadron. The pilot population of each squadron is roughly 40. In total, there are roughly 280 active MH-60S pilots in the fleet at any one time, all with different skill sets and mission experiences. It should be noted that all pilots initially train to the same skill sets in the FRS. Squadrons, based on their operating requirements, may perform these mission sets more or less frequently. For example, HSC-25 in Guam is the primary SAR asset for the Northern Marianas Islands. Thus, it prosecutes significantly more search and rescues than her sister squadrons in the continental United States, where the Coast Guard has primary SAR responsibilities.

With this diversity in squadrons in mind, HSC-3, the West Coast MH-60S Fleet Replacement Squadron (FRS) was chosen. Instructors are comprised of a mix of aviators from all the HSC fleet squadrons, thus ensuring a singular point of view of a particular squadron experience or geographic area would not be represented exclusively. The FRS instructor pilot pool offered the unique advantage of collecting the most skilled pilots throughout the HSC community and depositing them in one centralized location. Mission diversification among interview subjects is summarized in Table 3.

| Mission | Number of Pilots |
|----------------|-------------------------|
| SAR | 7 |
| NSW/TACTICS | 5 |
| FAM | 7 |
| MEDEVAC | 2 |
| AH | 5 |

Table 3. Mission experience among interview subjects. Subjects are often familiar with more than one mission area.

The audience, in this case experienced fleet aviators, was well known to and as well understood by the author (who was also the interviewer). As indicated, the author is also an experienced fleet aviator, and has flown the same model/type/series as the interview subjects. Of the several types of interview methods presented in [15], an informal in-person interview was chosen based on the advantages outline in Table 2. Per [15, p. 14], the author felt that open-ended questions, in which the key component of the question would be the insight that led the respondent to that conclusion, were of the most value for the purposes of this study.

Each interview was conducted with a written script in which notes were taken by the interviewer (Appendix A). The subjects were familiar with their particular cockpit environment, but were unfamiliar with certain Human Cockpit Interface (HCI) terminology and concepts. The author felt that if the subjects had a better understanding of different interface options, a more frank and revealing discussion would be the result.

Finally, following guidelines established in Table 4, a quiet, private interview room was used. In this case it was a briefing space which the pilots were both familiar with and provided convenient access as it was located in the squadron spaces. Based on the experience of the interviewer, pilots are relaxed and more open to discussion in a familiar environment.

| | |
|-----------------|---|
| Characteristics | Done with a written script |
| Advantages | Can explore answers with respondents Can assist respondents with unfamiliar words and concepts |
| Special Needs | Requires a quiet area to conduct the interviews |

Table 4. In-person informal interview attributes (After: [15]).

THIS PAGE INTENTIONALLY LEFT BLANK

IV. INTERVIEW RESULTS AND DISCUSSION

A. INTERVIEW RESULTS SUMMARY

The interview method described in Chapter III does not necessarily lend itself to easily quantifiable summary data as the bulk of the information is pilot comments about particular systems or cockpit tasks. These comments did tend to group in to several general areas of interest. Topics were:

- All nine subjects expressed the need for a MFD integrated moving map to aide in performing critical navigation tasks and for maintaining adequate situational awareness across the entire spectrum of missions. Eight of nine interviewees had some experience with the Digital Map Kneeboard (discussed in Chapter V) which was developed independently from the cockpit instrument suite. Interviewees stated that the kneeboard device was a poor substitute for a fully integrated moving map. Pilots believed that use of the knee board version was cumbersome and presented a significant disruption to their normal scan pattern. They all stated that integrating the functionality of the DMK in to the Multi-Function Display (MFD) would be the optimal solution based on their aviation experiences with cockpit scan patterns and the elimination of the distractions caused by "head-down" cockpit tasks. The negative effects of this type of cockpit activity will be discussed in Chapter V.

- Five of nine subjects expressed dissatisfaction with the current implementation of the Forward Looking Infrared (FLIR).
- Four of nine subjects felt the current Programmable Key Interface (PKI)/Fixed Function Key (FFK) user interface was difficult to use.
- Four of nine subjects felt there were readability issues with various aspects of the digital flight and malfunction indication displays.

A more in-depth summary is outlined in Appendix A, and raw interview data is found in Appendix B.

B. GENERAL INTERVIEW DISCUSSION

The interview process was revealing to say the least. Topics ranged from display symbology color to menu depth. A more detailed summary of these topics are presented in Appendix A. With every subject, however, the interview quickly turned to the issue of geo-referencing the aircraft during missions. Of the eight subjects familiar with the DMK, all eight stated that the usability of a moving map would be greatly enhanced if it was implemented on the MFD instead of the DMK. Two subjects recommended replacing the center back-up instruments and replacing it with a fifth MFD used solely for geo-positioning while another requested robust viewing options including ego and exocentric views.

In the course of the interview process, it became very clear to the author that this thesis would not be a simple or straightforward usability analysis on an existing cockpit function or task.

The focus of this thesis quickly turned to an exploration as to why user expectations were not met in the MH- 60 aircraft regarding the incorporation of a mission critical information display (specifically, the need for a MFD moving map). The author then set out to answer the question of how the U.S. Navy pilots could be so grossly under-serviced and how this problem could be rectified in future acquisitions projects. To that end, the remainder of this thesis will focus on the issues surrounding the design methodology used during the MH-60 development, and dedicate efforts toward ascertaining what went wrong and how aircraft system design and acquisition methods could be improved. We will first begin with the discussion of the importance of moving maps.

C. SPECIFIC DISCUSSION ON MOVING MAPS

One item of particular interest was a theme for which all nine subjects expressed as a concern: the need for a usable moving map. Seven subjects directly commented that the current implementation of this functionality, the Digital Map Kneeboard (DMK) was not a practical solution due to usability issues and was thus not used. One of those that did not comment on the usability of the DMK had never used the device and the other thought it was a useful situational awareness tool for non-pilot aircrew in the back. The drawbacks of the kneeboard DMK solution will be explored in Chapter V.

Regardless of the mission, all nine subjects stated that some form of a map, or a way for the pilot to maintain geographic situational awareness, was a must to keep the

pilots from cognitive overload given the complexity of the missions they were flying. This will be further discussed below.

V. MOVING MAPS AND THE COMMON COCKPIT DESIGN METHODOLOGY

A. MOVING MAP RATIONAL

Before discussing a moving map specific to the Common Cockpit, a discussion on the generalities of moving maps is warranted.

1. Moving Maps

In general, moving maps all provide the same information: a representation of the relationship between the location of the user and a specific geographic area in which the user is located. As the user's position changes, the map adjusts to keep the user's geospatial position and thus geospatial awareness accurate.

The benefits of moving maps as an enhancement to situational awareness in general are well understood by both government and private agencies and will not be discussed in this paper. This paper will specifically discuss moving maps in relation to general U.S. military flight profiles.

The U.S. military recognized the need for a moving map as far back as 1979. The first digital map was created by Harris Corporation for the U.S. Air Force F-117 Nighthawk. Since then, moving maps have been installed by several different companies on aircraft, such as the C-130, F-16, F/A-18, AH-1Z, UH-1Y and the AH-64, to name a few [37].

MH-60S and MH-60R mission sets were briefly outlined in Chapter II. In review, the missions vary for purely over water actions including Anti-Submarine Warfare (ASW) to

overland missions such as Combat Search and Rescue (CSAR or AH). From the author's experience, seldom do these missions cover exclusively one type of geography over another, but instead start in one geographic region and end in another. This can be attributed to the fact that Navy helicopters are often ship-based but work in the littorals. Even in the case of open water operations, artificial boundaries are instantiated by naval battle groups to de-conflict dissimilar operations. An example of this would be ensuring low-flying aircraft such as helicopters do not inadvertently wander in the carrier landing pattern of much faster fixed-wing aircraft. Even purely ASW work requires to some extent knowledge of sea bottom topography. Lockheed Martin came to this same conclusion while analyzing the MH-60R requirements for the ASW mission and initiated an Independent Research and Development (IRAD) project to explore possible implementations [38].

Generally, from the author's experience, a sizable portion of Navy flying is either overland or in close proximity to some form of land mass or relevant geographical partitioning. This may include international maritime borders as well as designated "restricted" areas where entry would violate national or international flight regulations. Thus, one should conclude that geographical situational awareness is applicable to both overland and oversea mission sets and is thus entirely applicable to the MH-60S and MH-60R and their associated missions.

2. Moving Map MH-60S Implementation

With the corporate understanding of the benefits of moving maps prevalent in the helicopter community and

aviation in general, the question is begged on how did a moving map get overlooked in the original common cockpit design process?

Prior to [30], the U.S. Navy never specifically identified a moving map solution to navigation and other functional requirements defined in the ORD. This has the potential to make a coherent human-cockpit interface design difficult and recommendations on this approach will be discussed later. Sprinkled throughout the ORD were numerous requirements to display some type of geo-spatial information to the crew. For example, section 4.2.1.1, in discussing the Airborne Mine Counter Measures (AMCM) functional requirements states the following:

A precise helicopter AMCM minefield navigation system is required to accurately determine, display, record and report geo-spatial position of mine-like object.. cockpit displays shall provide the capability for the aircrew to maneuver the helicopter along a desired/selected track. [30]

Consideration was given to an integrated moving map for the Common Cockpit prior to [30]. Tasked by the Navy, Naval Research Laboratory did discuss the need for an integrated moving map for the MH-60S in 2001. Although the initial plan was to implement the first MH-60S moving map to support the CSAR mission, the major thrust of the program was to help support the ASW and MCM mission [39]. The push for the moving map was also driven by the success that moving maps had in providing heightened situational awareness in the F/A-18 Hornet and AV-8B Harrier [40].

Prior to production aircraft 120, the possibility of MFD integrated moving map was moot. The first generation of

the Common Cockpit included as part of its hardware a key computing device called the Flight Mission Computer (FMC) that lacked sufficient computing power to implement a moving map [41]. Per [5], the FMCs "are provided for information processing and data management. The FMCs execute Flight Management Program (FMP) software and provide all flight management functions" [5, p. VII-15-20]. Since production aircraft 120, however, the all FMCs in new production aircraft, as well as fleet aircraft, have been replaced with the Mission Computer (MC), which is capable of driving the necessary hardware and software to utilize the hardware map features already located on the MFDs [41],[42].

Even with the temporary technical limitation posed by the FMC, the reason that a moving map was not an initial requirement in the Common Cockpit is still not completely clear. As discussed above, the benefits of a moving map are well known and would have been one of the fundamental issues discussed by any design team based on ORD functional requirements. Thus, the cockpit design methodology should at the least have driven the inclusion of the moving map requirement once technical limitations were overcome. Why didn't it? One possible reason could be the cockpit design process used by Lockheed Martin.

3. Lockheed Martin Cockpit Design Methodology

According to [43], Lockheed Martin loosely followed in-house systems engineering design methodology titled "Process Guidance Series—System Engineering: Human-Computer Interface Requirements (HCIRS)." This methodology was more or less

standard throughout the industry and eventually became formalized as the Department of Defense Architecture Framework (DoDAF), Version 1.0.

It should be noted that without a singular first-hand view of the entire Common Cockpit design process or clear documentation at every step, it is impossible to accurately map each individual design stage to the components of the Lockheed Martin methodology. Methodology is further obscured by the fact that exact composition of each group (Human Factors Engineering, Software Engineering, etc.), as delineated in [6], cannot be accurately determined within the scope of this thesis. That said, documentation provided by Lockheed Martin to the author as well as [43], indicates that this methodology was generally followed. It should also be noted that according to [44] the specifics of human factors are "greatly influenced by customer requirements and expectations."

**a. Lockheed Martin Process Guidance Series
Systems Engineering: Human-Computer
Interface Requirements (HCIRS) Overview**

Lockheed Martin's design methodology is a systems engineering approach to all encompassing approach to Human Computer Interface (HCI). It uses a straightforward iterative design process for development, design and test implementations of HCI requirements.

b. Systems Engineering Process

Reference [6] is a framework to help system engineers develop a usable HCI for users of any type of computer system and is not specific to aviation

applications. It provides "recommended contents for those sections of a system, subsystem, configuration item, or interface requirements specification used in documenting HCI requirements [6, p. 7]. These recommended contents are outlined in Figure 8.

| | |
|----------|--|
| 1. | Scope |
| 1.1. | Identification |
| 1.2. | Purpose |
| 1.3. | Introduction |
| 2. | Applicable Documents |
| 2.1. | Government Documents |
| 2.2. | Non-Government Documents |
| 3. | Interface Requirements |
| 3.1. | User Specification |
| 3.2. | Function and Task Elaboration |
| 3.3. | Accessing the Computer |
| 3.4. | Input Devices |
| 3.5. | Output Devices |
| 3.5.1. | Kinds of Output Devices |
| 3.5.2. | CRT and Plasma Panel Screens |
| 3.6. | Major Interface Considerations |
| 3.6.1. | Language/Vocabulary |
| 3.6.2. | Form of Dialog |
| 3.6.2.1. | Question-and-answer Dialogs |
| 3.6.2.2. | Form-filling Dialogs |
| 3.6.2.3. | Menu Selection |
| 3.6.2.4. | Graphic Interaction |
| 3.6.2.5. | Command Languages |
| 3.6.2.6. | Query Languages |
| 3.6.3. | Data Entry |
| 3.6.4. | Text Entry |
| 3.6.5. | Windows |
| 3.6.6. | Colors |
| 3.6.7. | Cursors |
| 3.6.8. | Response Time |
| 3.6.9. | Help Messages |
| 3.6.10. | Error Messages |
| 3.6.11. | System Feedback |
| 3.7. | Human-Computer Interface Configuration |
| 3.8. | Documentation |
| 4. | Qualification Requirements |
| 4.1. | General Qualification Requirements |
| 4.2. | Special Qualification Requirements |
| 6. | Notes |
| | Appendices |

Figure 8. Lockheed Martin Human Computer Interface Requirements (HCIRS) contents (From: [6]).

Per [6], the contents are meant to describe the interface between the user and the system. The "how" of software and hardware design is documented in separate specifications [6].

c. The Iterative Process

Reference [6] has divided the design process in to eight distinct steps (Figure 9).

- Step 1. Generate an Operational Concept
- Step 2. Define the Users
- Step 3. Elaborate Functions and Tasks
- Step 4. Analyze Human Tasks and Interfaces
- Step 5. Specify Computer Interface Requirements
- Step 6. Define a Human-Computer Interface Configuration
- Step 7. Specify Documentation
- Step 8. Specify Qualification Requirements

Figure 9. Lockheed Martin eight step HCI design process (From: [6]).

As stated earlier, this process is both sequential and iterative. Design teams will make decisions, review them with users and modify these designs an indeterminate number of times until a consensus is reached as to meeting the functionality of that particular system. "User evaluations of the prototype are conducted at various iterations to obtain users' feedback early and incorporate it into the design, as appropriate" [6]. Iteration occurs between steps three and eight of the design process.

Step three is the step in which "functional allocation" occurs. Here, "functions are allocated to humans or to machines" [6, p. 27]. Allocation decisions are based on several criteria including human and machine limitations and data from functional analysis, as well as past engineering experience and cost-effectiveness of design. To some extent, the remainder of the iterate process refine this mapping of functions to functionality and get it to work in the context of usability. This in turn makes step three the most crucial to the entire

iterative process. Any missteps here may prove irrecoverable for the remainder of the process until iteration returns to the starting point. This logic can also be applied to the non-iterative part of this process starting at step one (Generate Operational Concept). If the concept is mal-formed, the entire process will thus be malformed since there is no way to recover without a complete re-initialization of the entire design process.

In summary, the reader should keep in mind that the ultimate goal of this design process is to map required system functionality (step 3 of Figure 9) to a specific functionality within the final design (step 8 of Figure 9). Once this criterion is met, it is possible to declare the system goals complete. This means that unless a very specific moving map requirement was specified (which was not the case in the original MH-60S ORD), the final design could vary widely and would most likely be the best solution from an engineering standpoint, not necessarily a usability standpoint.

4. Digital Map Kneeboard (DMK)

The introduction of Block II and III production models and the implementation of the Armed Helo mission brought the need for a moving map to the forefront. Hamstrung by the FMC limitation as discussed in Chapter V, NAVAIR opted to integrate a kneeboard moving map and introduced a change to the MH-60S ORD that specifically outlined a kneeboard moving map specification [30]. Section 4.3.9 of [30] defines the requirement:

A kneeboard moving map which is useable during both unaided and Night Vision Device (NVD) flight will provide digital navigation for each pilot. The aircraft will be modified to provide primary navigation (either INS or GPS) position information and power supply to support the moving map. The MH-60S kneeboard moving map shall be capable of pre-flight loading and in-flight display of National Geospatial-Intelligence Agency (NGA) raster product format data and vector data that incorporates and overlays geo-referenced navigation and waypoint/flight data onto a common map background. The moving map shall be capable of input and output in either latitude/longitude or Military Grid Reference System (MGRS). When the Navy implements the Common Grid Reference System (CGRS), it will be incorporated into the moving map system. A cockpit moving map display greatly increases pilot situational awareness. A self-contained moving map system will be an objective system for the MH-60S.

If a need for moving map was realized in the ORD, why was the kneeboard solution incorporated and not the "self-contained moving map solution" described above as the final solution? Before this question can be answered, a brief discussion of the DMK will be undertaken to orient the reader with the kneeboard solution.

a. Digital Map System

The answer to the Change 2 ORD requirement was the Digital Map System (DMS). Developed by Vertical-flight Systems, Test Analysis and Research (VSTAR), a government owned facility, the DMS consists of three distinct components (Figure 8 and Figure 9): a Digital Map Junction Unit (DMJU), a Digital Map Loading System (DMLS) and three Digital Map Keyboards (DMK) [7].

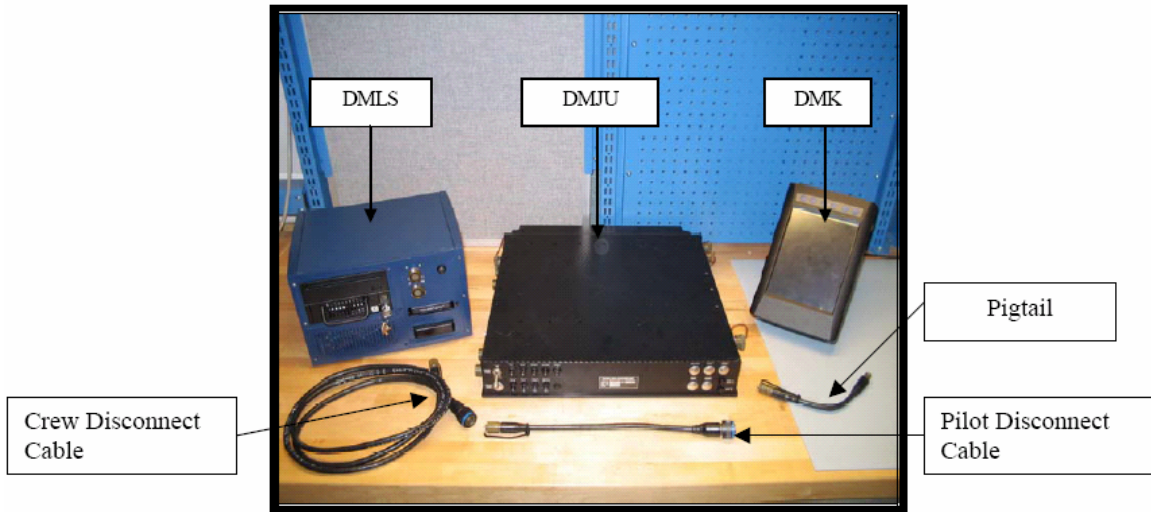

Figure 10. DMS (From: [7]).



Figure 11. Current fleet DMK. Pen included for size reference only.

The current kneboard moving map implementation was an offshoot of an older Fujitsu touchpad laptop that had been tested previously. Based on this concept the current kneboard was designed and prototyped by NAVAIR during 2004. Production of operational models was handled by the Army

(AMRDEC) Aviation and Missile Research, Development and Engineering Center—Prototype Integration Facility (PIF) in Huntsville (Redstone Arsenal), Alabama [45].

Designed to be worn on the pilot's thigh while seated in the aircraft, the kneeboard is approximately the size a medium-sized book or standard military kneeboard in length, width and thickness (Figure 11 and Figure 12) and weighs around four pounds [8]. User Human Machine Interface (HMI) controls consist of an 8.5-inch (diagonal) resistive touch screen, on/off switch, touch screen disable switch, backlight control and right mouse click switch. Software consists of Microsoft Windows XP© running the AN/AYQ -26 Topographic Support Set (Figure 13). This set integrates aircraft navigation data with respect to digital maps [7], Forward Looking InfraRed (FLIR) composite video input, two 10/100 Ethernet ports and a MIL-STD-1553B Data Collection PCB [8].



Figure 12. Current fleet DMK. Pen included for size reference only.

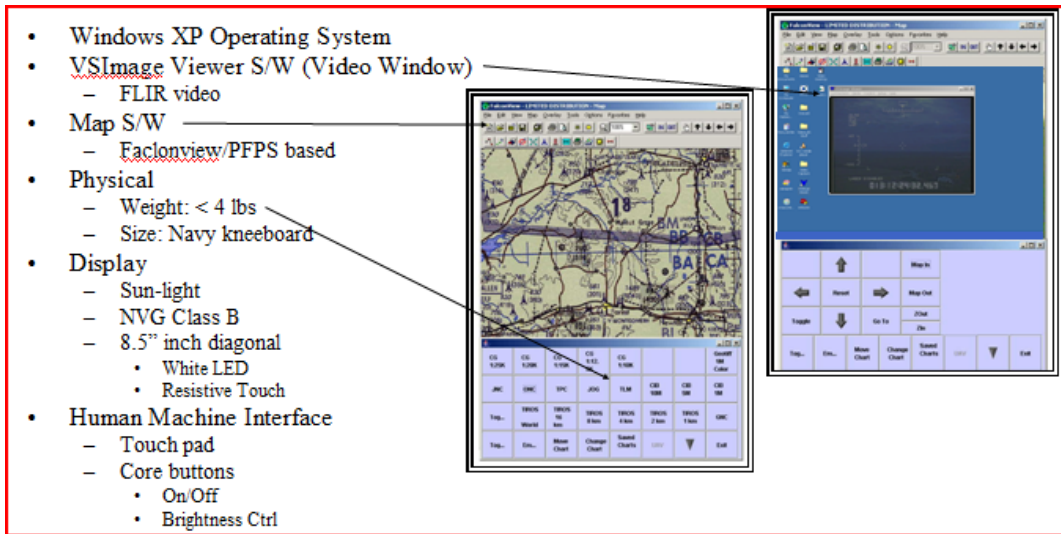

Figure 13. DMK Specifications (After: [8]).

Of particular interest is the integration of the mission planning software FalconView© to the DMK. FalconView© is a common tool used by aircrew across all the services for mission planning.

b. Pilots Likes/Dislikes and Limitations of Heads-down Devices

The in the scope of the interview conducted for this thesis, the DMK was universally discounted by all pilots interviewed as a useful front seat tool for any type of relevant geospatial situational awareness information. Based on comments documented in Appendix B, this is primarily due to the heads-down nature of the DMK. Interview subjects reiterated that the DMK was much more a distraction than help to mission accomplishment.

This finding is not surprising. The negative impact of any heads-down activity in a cockpit is well documented and blamed for a number of aircraft mishaps [46] analyzed National Transportation and Safety Board accounts

of accidents attributed to crew error. Of those reported, "nearly half of these accidents involved lapses of attention associated with interruptions, distractions, or preoccupation with one task to the exclusion of another task." Of these distracting activities, four categories were defined:

- both internal and external communication
- searching for VMC traffic
- responding to abnormal situations
- head-down work

Reference [46] also analyzed 107 of NASA's Aviation Safety Reporting System (ASRS) reports that involved competing tasks. Sixty-nine percent of these reports were attributed to "either failure to monitor the current status or position of the aircraft, or failure to monitor the actions of the pilot who was flying or taxiing" [46]. In 35 of the ASRS reports, the pilot not flying was distracted from monitoring the flying pilot from other tasks, of which 13 involved some kinds of head-down activity.

Airbus also conducted a review of safety reports and found similar data [16]. Based on the U.S. Aviation Safety Action Program (ASAP), Airbus stated that "interruptions and distractions are the main threat facing flight crews." Airbus defines a threat as "a condition that affects or complicates the performance of a task or the compliance with applicable standards." In reviews of the

ASRS, Airbus calculated that head-down activity accounted for 16-22 percent of the factors involved in interruptions and distractions, as listed in Table 5 [16].

| Factor | % of Events |
|---|--------------------|
| Omission of action or inappropriate action | 72 % |
| Inadequate crew coordination, cross-check and back-up | 63 % |
| Insufficient or loss of lateral or vertical situational awareness | 52 % |
| Inadequate or insufficient understanding of prevailing conditions | 48 % |
| Slow or delayed action | 45 % |
| Incorrect or incomplete pilot / controller communications | 33 % |

(Sources : Flight Safety Foundation - ALAR - 1998-1999)

Table 5. Interruption and distraction factors (From: [16]).

The effect of these interruptions and distractions, in which head-down activity comprises almost a quarter, is to "break the flow of ongoing cockpit activities," including [16]:

- Standard Operating Procedures (SOPs)
- Normal Checklists
- Communications
- Monitoring tasks
- Problem solving activities

The effects of head-down activity and the resultant laundry list of consequences above are no surprise to seasoned fleet aviators. Limiting head-down activity to a minimum is a golden rule taught in flight school and constantly reiterated during countless safety briefs and

squadron level training. The head-down environment is so distracting that announcing that the non-flying pilot is "heads-down" is very common practice and highlights the need for extra vigilance by the flying pilot as well as other flight crewmembers. Physiological affects aside, head-down is not an activity that should be performed often in the cockpit.

This knowledge of the inherent dangers of head-down can also be interpreted from the U.S. Navy's own research into glass cockpits. In researching moving-map systems for multi-functional helicopter missions, the Naval Research Laboratory did not even consider a kneeboard application and instead focused its research on an in-dash MFD integrated solution [47],[40].

Finally, [48] describes one of the potential hazards of advanced interfaces interfering with aircrew situational awareness. It warns that "too much programming and head down times [that] takes place at low altitude, and during time of intense tactical activity," is a concern when developing a new interface system (p. 8).

c. Planned Obsolesce of the DMK

Although sold as a solution to the moving map issue, NAVAIR did recognize that it was not the ideal solution. Per [7] and [30] this implementation of moving map functionality was inferior to a MFD integrated solution: "but the ultimate solution would be to integrate the moving map system into the normal OSI on the mission display [7], p. 10]."

Other than the fact of denying the users of the MH-60S access to a known superior navigation system in the here and now, planning for a major systems change after the aircraft has started full-rate production is an expensive proposition and a well-known acquisitions "no-no" and harkens to the now-defunct serial-approach acquisitions process. Per [9] the most costly place to implement product changes are after operational testing or full-rate production as shown in Figure 14.

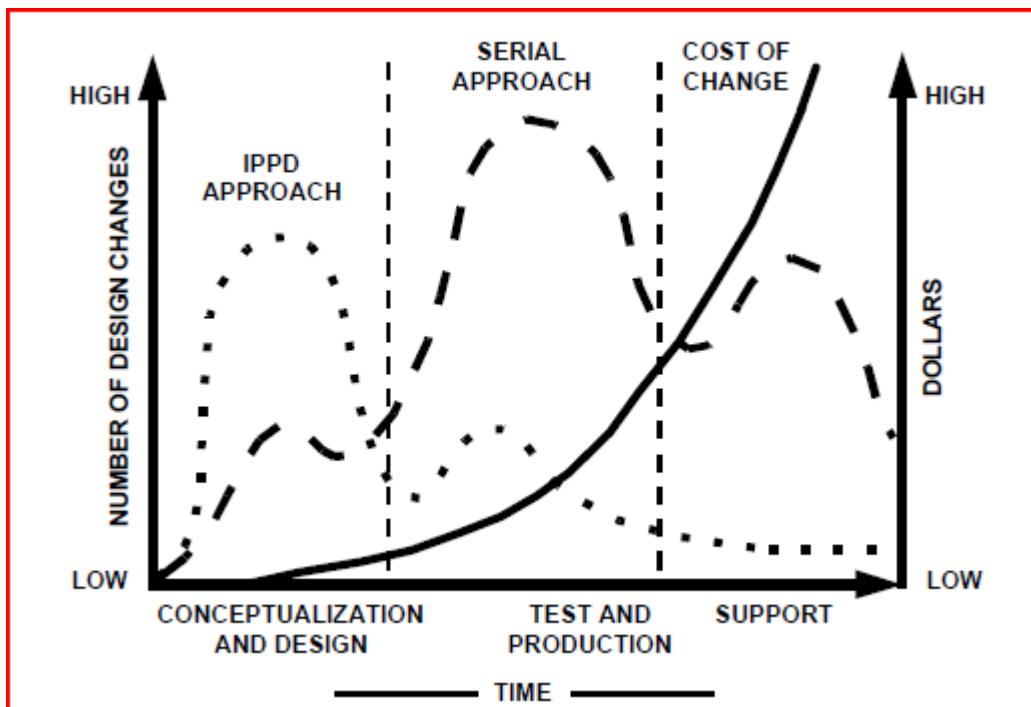

Figure 14. Cost of design changes as a function of time (From: [9]).

B. DESIGN METHODOLOGY FLAWS AND A SUGGESTED ALTERNATE DESIGN METHODOLOGY

Clearly, the DMK is a poor solution to the moving map issue. This statement can be made not only based on research presented above but also validated by nine of nine

pilots interviewed requesting the integration of a moving map despite the fact that one already exists in the DMK. The question is still begged: how did the DMK become the solution? Per [49], the issue was timing. NAVAIR realized that the block II Armed Helo navigation requirements could be solved by a moving map but was still limited by the FMC as previously discussed. The MC was planned as an upgrade but would not be ready in time for block II incorporation. The solution was the DMK. But given all the issues with a head-down display, why was this solution not rejected as inadequate as interview results so clearly indicated? The answer could lay in the standard HCI design methodology utilized by Lockheed Martin.

The primary issue in the design process could be the incorporation of previous designs in the generation of HCI requirements as described by [6]. This step calls for the "study of earlier similar systems to identify firmly established interface practices and standards [6, p. 9]. The potential pitfall here is the earlier system being reviewed. If that design is flawed, and that flaw was not recognized by the design team, the fundamental flaw has the potential to be carried over to the new design. Give the discussion of head-down issues from above, the conclusion that this is precisely what happened in the DMK can be reasonably drawn.

Although in itself the inclusion of a prior design is not a bad idea, somehow a useless moving map solution was still produced by the design methodology. What can be done to help eliminate this chink in the design armor? A better

and ultimately more efficient approach to cockpit design may be a design philosophy commonly known as Crew-Centered Design (CCD).

1. Crew Centered Design Philosophy

The Crew Centered Design (CCD) concept is similar to the Lockheed Martin/DoDAF methodology in that it professes the same iterative approach to design in which implementations are prototyped and tested. It differs from the industry standard HCI systems engineering approach in that it is less of a rigid methodology and more of a philosophy and emphasizes a more holistic view of cockpit systems integration with flight crew usability as a key component of that system. CCD places a much greater importance on input from experienced aircrew personnel "at the beginning of, and throughout, the cockpit design process" [50].

Although each instantiation of the industry standard iterative systems engineering process centered HCI design methodology may be different from organization to organization, generally, they all follow the model detailed in Figure 15. This representation almost maps step for step to the Lockheed Martin process described in an earlier section of this thesis.

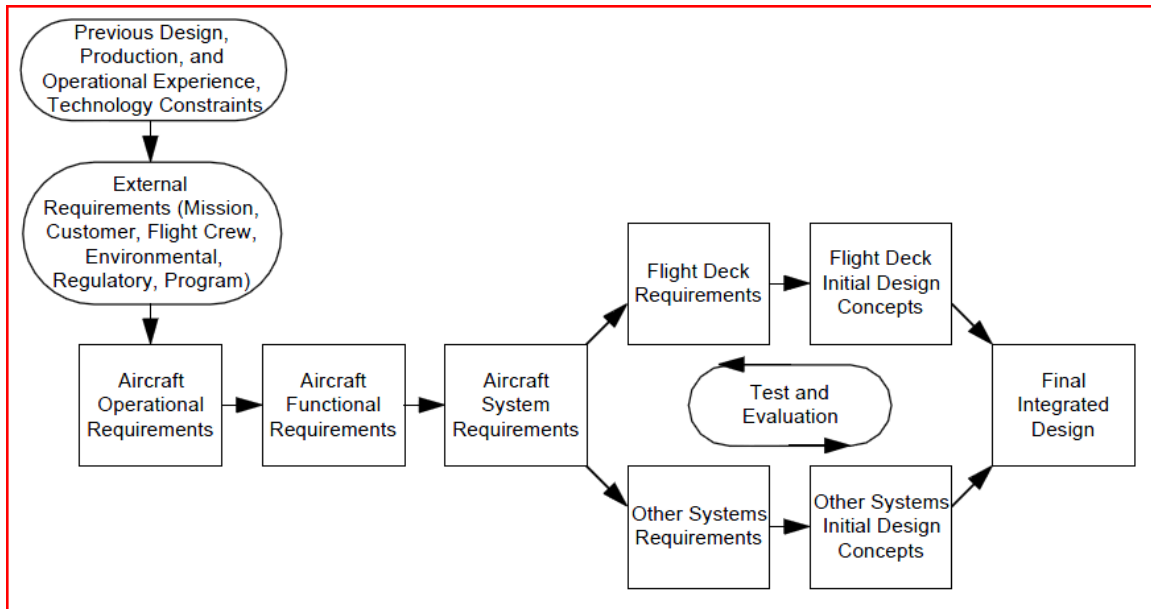

Figure 15. Systems engineering iterative HCI design process (From [10]).

While utilizing the general structure from Figure 14, the Crew Centered Design philosophy takes a completely different view of what is important in cockpit design. It de-emphasizes the performance of individual components and the sterile implementation of functionality and instead views success as how well the crew and cockpit perform together in the accomplishment of a given task. To this end, CCD places a much larger emphasis on the inclusion of the flight crew in every step of the design process [10]. Fundamental components of CCD include:

- Acknowledgement that the flight crew has the ultimate responsibility for the aircraft [51].
- Inclusion of the user (aircrew) more intimately in the design process [10].

- Consider the usability of the cockpit as a major system such that it equivalent to engines and airframe integration [10].
- Total flight crew/flight deck performance is more important than performance of individual components [10, p. 7]
- Test and evaluation should occur as early in the design process as possible to avoid implementation of poor design decisions [10].

The Crew-Centered Design philosophy applied to the traditional design methodology is depicted in Figure 16.

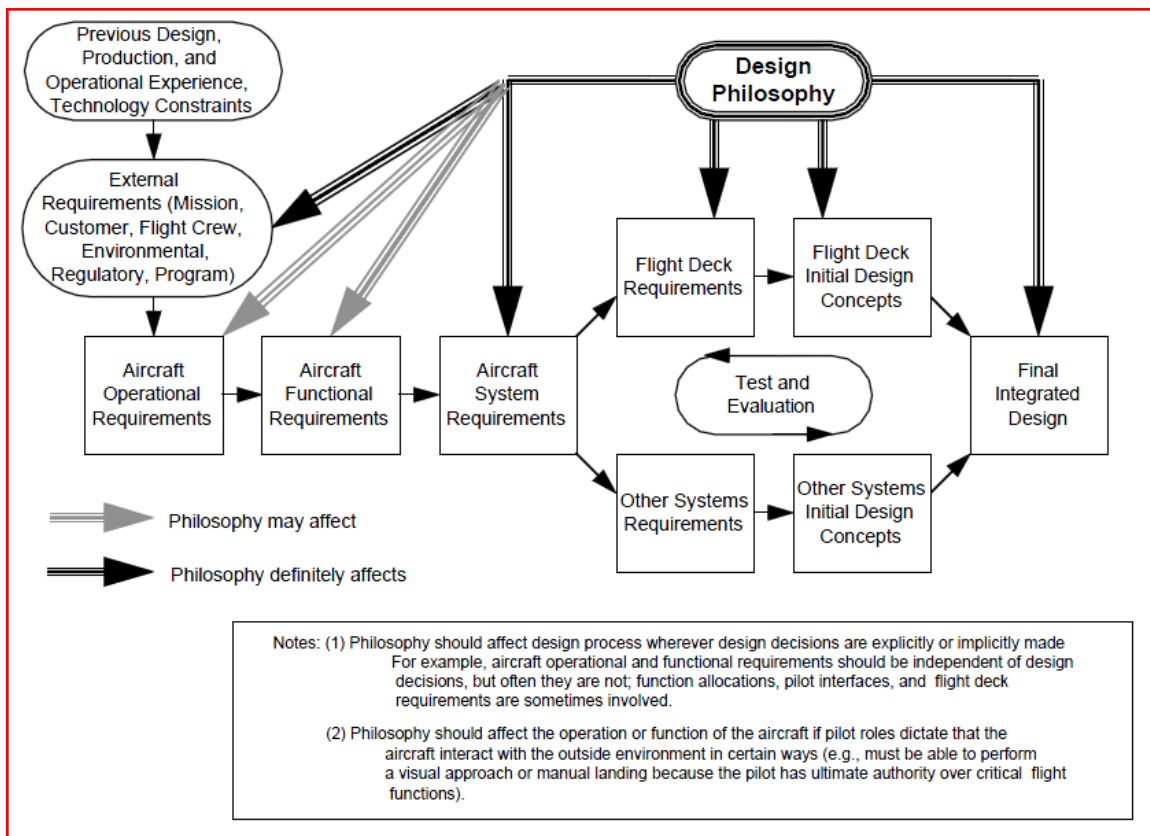

Figure 16. Inserting the Crew-Centered Design philosophy in to the traditional design methodology (From: [10], p. 9))

As its name implies, one of the major elements, if not the major element, is frequent and focused input by the experienced aircrews that may operate in that cockpit environment.

An optimized design and analysis process [Crew-Centered Philosophy] should take advantage of aircrew input. The aircrew, as a user, can provide a tactical evaluation of the design product and provide valuable insights. [50, p. 1]

2. Recommended Changes to Lockheed Martin HCI Design Methodology Based on the CCD Philosophy

There are several areas on which the application of the CCD philosophy would enhance the Lockheed Martin design process. These include:

a. Use of Design Methodology Specifically Developed for Cockpit Design

Design fundamentals and operating environments are not the same across the HCI spectrum. Fundamentally the LM method and its successor DoDAF are a broad approach to general HCI design. Given the highly dynamic environment of the flight deck, a set of very specific usability requirements exist. Reference [52] argues that "In the complex, dynamic, tightly regulated environment of aviation, the challenge of performing a usability evaluation expands considerably in comparison to evaluation of traditional human-computer interaction (HCI) applications" [52, p. 396]. Unlike other stationary systems that are captured by general HCI design methodologies aircrew face a much more dynamic and thus fundamentally different design context. Regardless of the current task for the aircrew "The most important task

is *aviating*—keeping the flow of air over the wings such as to maintain lift [53, p. 460] That is exemplified in the flight school mantra of *aviate, navigate, communicate!* Regardless of secondary tasks these three tasks must still be accomplished with absolute precision since the price of failure usually catastrophic. There is therefore a constant competition in the flight deck environment for the resource of pilot attention.

The competing tasks involve maintaining *situation awareness* for hazards in the surrounding airspace, *navigating* to 3-D points in the sky, following *procedures* related to aircraft and airspace operations, *communicating* with air traffic control and other personnel on the flight deck, and *monitoring* system status. [53, p. 460]

This specific task environment cannot be said of a user of a desktop terminal or even an operator of a sophisticated nuclear power plant control station for which a general HCI methodology would cover. Reference [6] does attempt to make this point. In step one, it directs systems engineers to capture “operational modes; and any special environmental conditions that must be accommodated by the system [6, p. 27]. Depending on the expediency of the project, this broad brush approach to capturing the operating environment has a lot of potential to miss crucial elements. Plus, understanding that the fundamentals described above are common to any cockpit design, it seems a waste of resources to continually re-invent the wheel for each functional requirement.

b. Cost Effectiveness Must be Evaluated from a Holistic Standpoint

Limiting cost as a design criteria: Per the Lockheed Martin method "the most cost-effective design alternative is selected [6, p. 26, Figure 6] during step 3 of the iterative design process. Although cost is an important element, it should not be applied as the bottom-line selection criteria for each individual function. CCD's philosophy of viewing the system as more than the sum of its parts must also be applied to the cost criteria. A functional requirement that costs more may in fact drive down the cost of a related function. Thus, cost comparison may be better served by evaluating the effectiveness of aircrew tasks (or combinations of functions). For example, if "navigation" was evaluated as a task, several functional requirements may be included in this grouping. Since CCD is crew-centered and more dependent on "operator input and experience" [50, p. 1], there is a greater chance that aircrew will recognize that task accomplishment would be the criteria for success instead of simply meeting a functional requirement. In short: meeting a functional requirement does not mean that the task is accomplished in the most efficient way.

c. View the Cockpit as a Sum of Its Parts for Design Decisions

Eliminate a function by function approach to design: The current accepted cockpit design methodology used on the Common Cockpit evaluates each functional requirement as a pseudo standalone requirement. CCD's holistic aircrew centered approach would tie common

functional requirements together and address that the whole may in fact be greater than the sum of the parts. It is easy to conclude that understanding the underlying need for geospatial situational awareness an experienced flight crew would immediately be able to connect the dots between different requirements for mapping.

In the case of the Common Cockpit, the need for geospatial positioning is scattered throughout each different aircraft block requirement in the MH-60S ORD. For this discussion the reader should note that this Common Cockpit requirements review has been limited to just the MH-60S ORD and does not factor in functional requirements defined in the MH-60R ORD.

Block I aircraft, section 4.1.2 of [30], as well as section 4.2.4.1 of Block II requirements, requires that the "MH-60S Communications and Navigation subsystems are required that will enable aircraft to operate within the Global Air Traffic Management (GATM) system [30, p. 14]." The GATM:

Is a concept for satellite-based communication, navigation, surveillance and air traffic management. The Federal Aviation Administration and the International Civil Aviation Organization, a special agency of the United Nations, established GATM standards in order to keep air travel safe and effective in increasingly crowded worldwide air space. [54]

Block II navigation requirements are outlined in section 4.2.1.1 of [30]. The AMCM specific requirements state that the "cockpit displays shall provide the capability for the aircrew to maneuver the helicopter along a desired/selected track (p. 19)." Unlike Block I and II

communication and navigation requirements, oddly Block III navigation and situational awareness requirements completely forgo any mention of GATM and instead section 4.3.9 describes the functionality requirements of the DMK discussed in detail above [30]. Communications and navigation requirements are also outlined in the Other System Characteristics subsection (4.6) in sections 4.6.6 and 4.6.7, respectively. Neither section mentions GATM but 4.6.7 outlines a functionality that could be construed as a situational awareness tool for GATM implementation:

The MH-60S helicopter shall have the capability to pre-load (both electronically and manually) geo-referenced navigation waypoints and flight plans, and provide the ability to manipulate these waypoints/flight plans in flight. The navigation system shall be capable of displaying to the pilots the position of surface contacts in and around the battle group. [30, sect. 4.6.7, p. 35]

A possible side effect of sprinkling functional requirements throughout, may be that the same functional requirement would be designed two different ways in two different projects. In the case of GATM, the Common Cockpit had no specific resultant usability other than a basic avionics package and rudimentary mapping abilities discussed below. This would then seem to meet the functional requirements specified by the MH-60S ORD sections discussed above. However, when Lockheed Martin designed the glass cockpit for the improved avionics suite for the Air Force C-5, the result was a true moving map based on Commercial-off-the-Shelf (COTS) packages found in the Boeing 777 among

others [55]. Of course without an in-depth analysis of the C-5 program, it is impossible to make this correlation with 100 percent accuracy.

Finding cockpit functional requirements should not be like hunting for Easter Eggs. By eliminating the stoic focus on stove-piped design, CCD ties these initially disparate functional requirements together by recognizing that they all accomplish the same basic task of geospatial positioning. The end design result would be a much better integrated mapping system that may potentially greatly reduce costs and improve system flexibility in the long run. The need to unify cockpit requirements in to one encompassing ORD is also a desire of the program manager per [35].

d. Carefully Consider Incorporating Previous Designs

References [56] and [11] indicate that one of base designs for the CC was the Light Airborne Multipurpose System (LAMPS) MK III Block II program. This is due to the fact that the MH-60R is a replacement for the current LAMPS SH-60B as stated earlier [4]. The LAMPS MK III system was introduced in 1983 and modified in 1992 [57]. Reference [11, sect. 6.2.2.1.1] states that mission display geosituational symbology was "designed to be compatible with the specifications for Naval Tactical Display Symbols (NTDS) to insure compatibility across Navy platforms." In keeping with good design practices, "an evolutionary—as opposed to revolutionary" [51]—was employed and much of the previous

display symbology was preserved. Having its roots in the 1980s display technology, NTDS is a bare-bones graphical display in which:

All the on-screen shape coding (including the contact and track shapes) is suggestive, in some way, of the object or parameter being represented in order to facilitate operator recognition. The top half of a geometric shape represents an air contact, an entire geometric shape represents a surface contact, and the lower half of a shape represents a subsurface contact. . The SAR Reference Point is the same shape as the "man overboard" Naval signal flag; the Pointer symbol consists of an arrow; the Torpedo Splash Point looks like a torpedo entering the water, and so on. [11, sect. 6.2.2.1.1]

Did this requirement to incorporate an existing design per step three of [6] unduly influence the final navigation display? Considering that the traditional navigation display of older U.S. Navy rotary-wing aircraft consists of green symbology on a black background (TACNAV of UH-3 first introduced in the 1960s, for example), one can compare that against the final CC design of Figure 17 and conclude that it did.

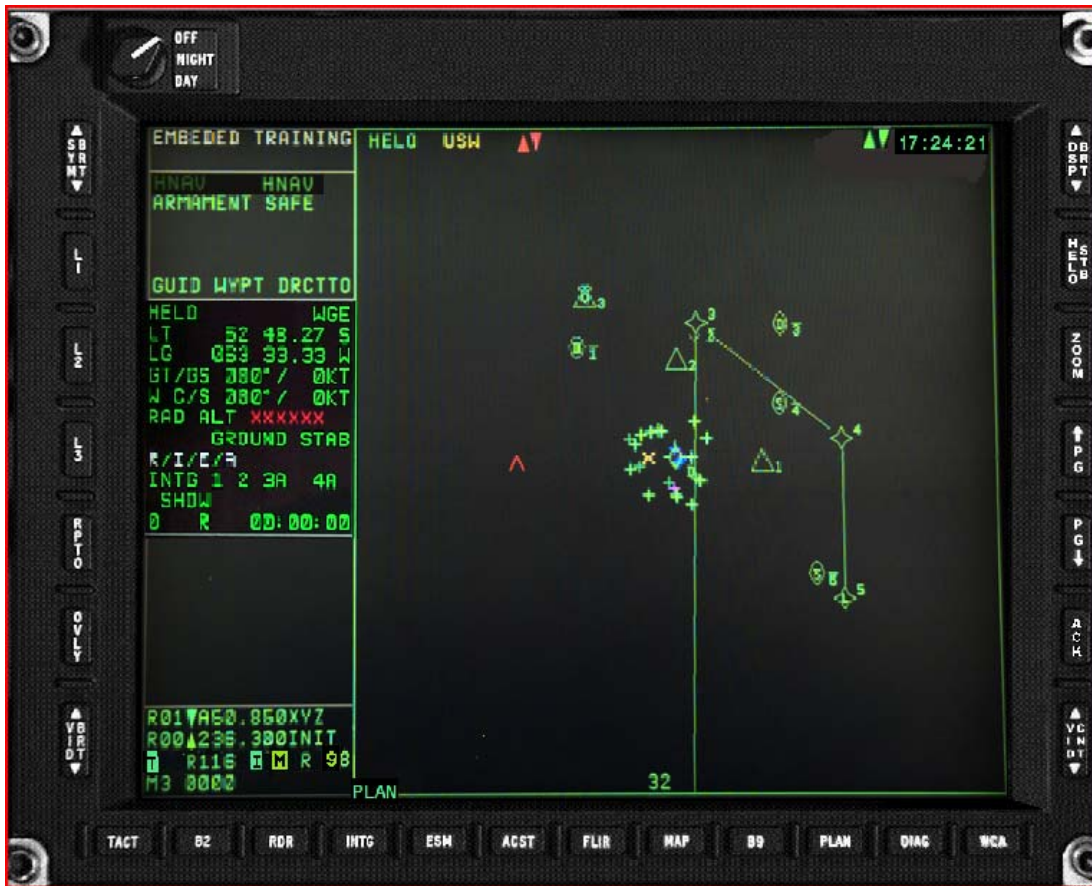

Figure 17. The current navigation display of the CC (From: [11, Keys cockpit interface simulator]).

It should be noted that the MH-60S ORD does not specifically state the need for a NTDS type display for navigation but does require the same general functionality per [30, sect. 4.6.7]. It should also be noted that utilizing the NTDS symbology in itself is not a bad idea as it leverages existing user knowledge. However, sticking with the exact display environment despite clear potential for improvement could be considered a mistake.

As such, it can be argued that the previous examples reviewed for the Common Cockpit are so far removed from an all-glass cockpit that their inclusion as a basis for design was more of a hindrance than help.

VI. CONCLUSIONS, RECOMMENDATIONS, AND FURTHER STUDY

A. CONCLUSION

On paper, Lockheed Martin met every functional requirement specified in the ORD in relation to the Common Cockpit. All applicable acquisitions instructions and design methodologies as required in the Department of Defense Directive 5000.1 were followed. The cockpit was tested, evaluated and approved by the Program Manager and delivered to the user. However, based on the results of the interview summarized in Appendix A and discussed throughout this thesis, the final design produced overlooked a critical display required to effectively and safely perform navigation tasks. In an attempt to fill this void, acquisition managers implemented a strap-on (kneeboard mounted) moving map system without adequate consideration to the usability of such a system. The result of this piecemeal approach to a moving map solution is the MH-60 cockpit in which the user is left wanting. How did this happen? Perhaps the process itself is to blame.

B. APPLYING CREW CENTERED DESIGN

As argued above, the Lockheed Martin design methodology, which is now standardized in the DoDAF methodology [58], is inadequate for glass cockpit design. It is too broad-based and does not adequately capture the essence of modern cockpit design. This failure manifested itself in the complete lack of a fully integrated moving map, despite the functional requirements (even with the

exclusion of the DMK requirements) and well-documented benefits to the aircrew for enhanced situational awareness. A better approach would be to detail glass cockpit specifics. This recommendation is discussed in the "Recommendations" section of this thesis.

If the CCD process was applied to the Common Cockpit requirements, what would the result be? Without a full implementation of CCD, it is impossible to say. However, a brief exploration of the CCD philosophy with regards to MH-60S ORD defined functional requirements can be had with the following assumptions:

- Step one of the CCD process (previous design, production, and operational experience, technology constraints) will only be considered. The end goal of this evaluation is simply to fulfill the requirement of step one of [6, p. 9] to "generate an operational concept".
- The latest version of the MH-60S ORD will be considered [30].
- Current technology limitations of the Common Cockpit will be considered but will not be a limiting factor. The assumption is that if a technology requirement exists, it is technology feasible to implement in the current common cockpit within reason.
- The normal manning requirements for a HCI design team for step one is made up solely by the author.

1. Functional Requirements Evaluated

As discussed above, Common Cockpit functional requirements are scattered throughout the MH-60S ORD. Grouping them together yields the following composite requirement: GATM capable (4.1.2); Maneuver the helicopter along a desired/selected track (4.2.1.1); kneeboard moving map which is usable during both unaided and Night Vision Device (NVD) flight (4.3.9); capability to preload geo-navigation waypoints and display, display the pilots position relative to surface contacts via Global Positioning System (GPS) (4.6.7). All requirements are from [30].

Even without the inclusion of the direct requirement to implement a kneeboard moving map in (4.3.9), in the author's opinion, the sum of the requirements, as well as practical experience with in-flight navigations in the form of paper charts, would lead experienced flight crews providing operational experience in step one to the conclusion that the fundamental task being accomplished by these outlined functional requirements is that of geo-positional situational awareness for the flight crew.

Finally, there are a host of considerations in choosing a moving map including perspective, orientation and size. But above all this there is the primary consideration:

A primary Naval Air Systems Command (NAVAIR) goal in specifying the new system is to enhance situational awareness (SA) and aircrew mission effectiveness without further burdening pilot task workload. [59, p. 1]

It is by this guiding requirement that the operational concept shall be defined.

2. Mapping Options

Now that the functional requirements have led the generation of an operational concept that includes a moving map, the team must determine what kind of moving map should be included. This is a job for the knowledgeable Human Factors engineers on the team.

One key to determining map orientation may be the context for which navigational directions are presented. Per [13, p. 110], "the language of the displays, in terms of ego-referenced directions like left, right, above or below, should match the language of the control that is also typically represented in such ego-referenced terms." The team should assume that if navigational directions are given to the pilot in terms of ego-centric commands like "turn left in 10 seconds," then the map orientation should be direction up. If commands are in the form of "turn north to a heading of 350 degrees," then north up is a more appropriate directional context for the moving map. The previous reference is known as ego-referenced or local guidance while the later is world referenced or global awareness [13, pp. 110, 113].

In [13] the two distinct views of Ego-Referenced Framework (ERF) or World-Referenced Framework (WRF) are described. Ego-Referenced Frame (ERF) provides the "user centered" view in which the view is presented as if seen from the user's eyes. World-Referenced Framework (WRF) is less ecological in nature. It presents a view in which the observer is able to orientate himself in the world of reference. It is a view in which the ERF is just one part of the larger world. Since Crew-Center Design places

emphasis on task accomplishment (in this case navigation), both perspectives will be viewed by the specific tasks they accomplish.

It should be clarified that for the bulk of their discussion, [13] discusses WRF as a function of both a three-dimensional (3D) and two-dimensional (2D) display. For the purpose of this thesis, a three-dimension representation for WRF is ruled out for one primary reason: there are not currently enough navigational data points to present any WRF operating environment in 3D. It should be noted that there is no reason to believe that a 3D environment suitable to WRF mapping as described in [13] could not be constructed in the near future. Both airspace management, as well as operational environments, could be modeled in 3D, much as they are for simulators. It is realistic to anticipate that near future operating environments will be mapped in 3D, much as Google Earth has done by converting 2D imagery into 3D maps. Therefore, 3D should be a consideration for future upgrade plans.

a. *Ego-referenced Frame*

In [13, pp. 110-111] ERF is described as "ego-referenced, forward viewing, zoom in, and 3D." ERF "mimic[s] the natural viewing of human observers as they walk through an environment [13, p. 111]." Ego-referenced refers to one of the four cardinal eye points a viewer can have: egocentric, exocentric perspective, exocentric 2D plan view (Figure 17), and exocentric 2D side view (Figure 18). For the purposes of this discussion, ego-referenced and egocentric are the same viewpoints as depicted in Figures 18 and 19.

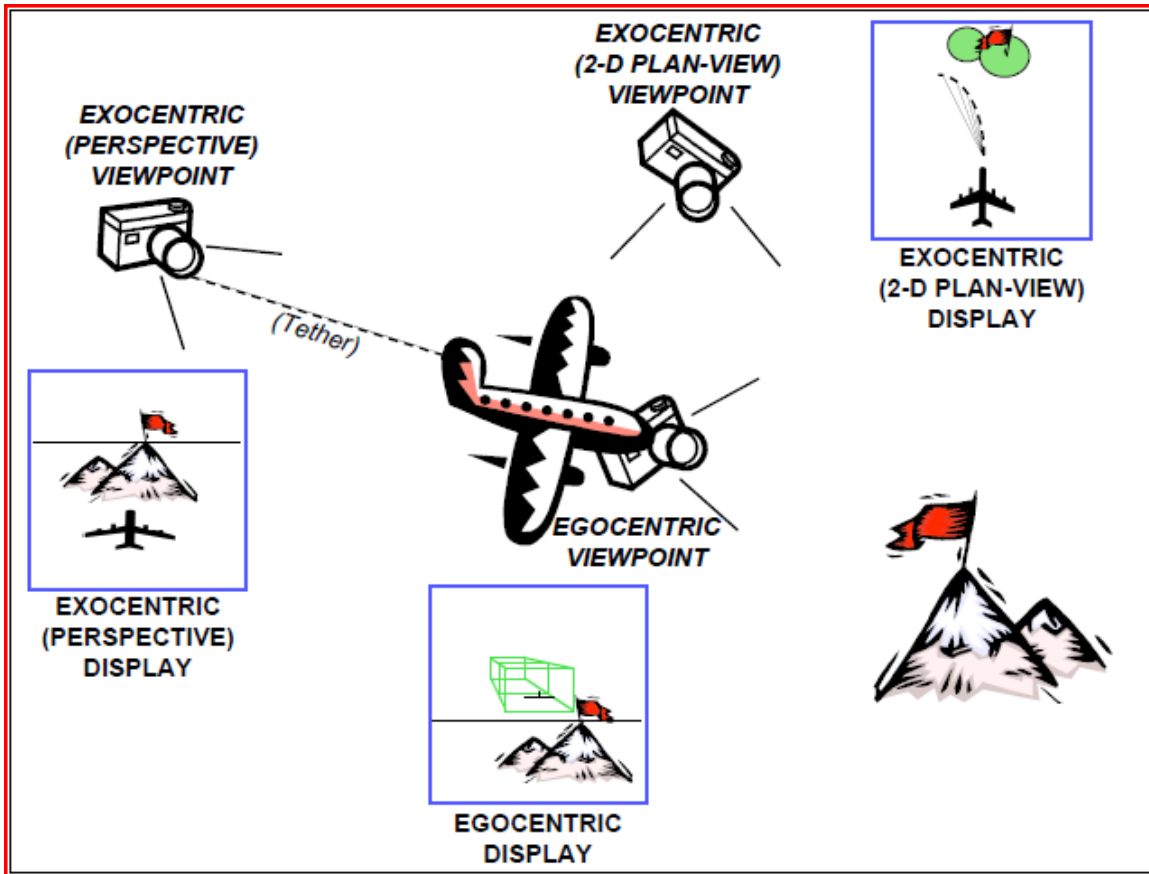

Figure 18. Egocentric, Exocentric perspective, and Exocentric Plan-view displays (From: [12])

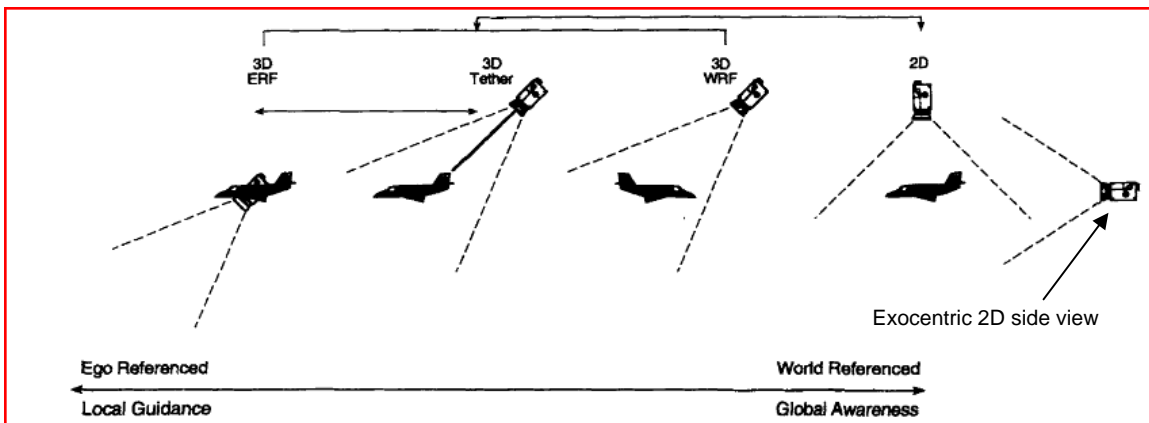

Figure 19. A progression of viewpoints from ERF to 2D planar view. Exocentric 2D side view is on the far right (After: [13])

b. World-referenced Frame

It can be stated that a 2D plan-view is nothing more than a specialized case of a 3D WRF in which there is no off-vertical-axis view. Per [12], the 2D plan-view is described as akin to the 3D WRF from Figure 18, but "where the viewpoint is 90 degrees to the world's plane." Despite the conversion from the 3D WRF to the specialized case of 2D, the three fundamental features of WRF described by [13, p. 111] are still valid:

- (a) they may need to be world-referenced to support communications with others who may not share the same momentary ego-frame of reference;
- (b) they should soon out or be wide angle, representing a much broader region of the world than does a local guidance display; and
- (c) the need for three dimensionality that was inherent in local guidance displays is mitigated by the desirability of a world-referenced frame; this is because a 3D display must by definition assume a particular ego-referenced azimuth angle.

3. 2D/3D Solution

Although it presents some very unique benefits to geospatial situational awareness, as discussed by [13] and [12], 3D also carries with it some significant baggage in today's cockpit. Three-dimensional representations would be a significant perceptive leap from the 2D paper charts and video displays in use today by flight crews. This may violate the "evolutionary, as opposed to revolutionary [51]" construct discussed previously. This point is made by [13, p. 113]:

Although counterarguments [for 2D plan-view maps] have been made in aviation that a moving aircraft or stabilized world display is more compatible with the pilot's mental model of the aircraft system (Johnson & Roscoe, 1972) and can provide as good performance.

It may also be limited by the technical limitations of current or near future display technology. To declare 3D as the primary source of navigation information for today's Common Cockpit would therefore be a stretch at best. To fully recognize the benefits of 3D, a Heads Up Display (HUD) and augmented reality, as discussed by [12], would have to be considered. This extensive modification to the Common Cockpit is well beyond the scope of this thesis. As a secondary source of geospatial reference, a simplified version of a 3D ERF display is a possibly, as will be discussed below.

a. 2D Moving Map

As discussed above, the benefits of a 2D plan-view moving map are undeniable. The question then arises as to what features this moving map would incorporate?

Through an interview of both fixed-wing and rotary-wing pilots utilizing several types of 2D WRF plan-view maps [59] concluded the following:

- Context switching (time to switch between different map views): "Faster is better accurately sums up the pilots' preferences with regard to all three time-to-switch functions (switching map modes, switching chart scales, and command lat[itude]/lon[itude] repositions

(p. 14).” No more than 1 second between context switches was generally acceptable (Section 4.1.3).

- Data update rates: In this case, faster is not better. Pilots preferred 15Hz [updates per second] displays over 20Hz displays (p. 14, Section 4.1.3).
- Map Positioning: North-up, track-up, centered, and decentered were considered. Most pilots found that more often than not that track-up generally proved more useful than north-up but both had their advantages depending on the situation. As discussed in [59, pp. 18, 19], pilots accomplished “certain tasks (e.g., reconnaissance) more effectively with a north-up map (p 19).” In both north-up and track-up, pilots preferred the ability to determine whether the aircraft was centered or decentered and to what degree off center the aircraft would be (Section 4.2.3).
- Zooming: The ability to both zoom-in and zoom-out on a map were shown to be beneficial. Of particular interest is the quick zoom-out capability in which a pilot can quickly attain a larger global situational awareness picture and then zoom-in to the original scale with a single button push (Section 4.3.2).
- Vector Moving Map Displays: Vector maps can have the same appearance and content of any

traditional chart but instead of being a digitally scanned picture of the chart are instead digitally rendered such that scaling and rotation have no effect on readability. "Vector maps are rendered from individually stored objects (p. 44). These objects include anything that would be found on a traditional map "including lines (i.e. roads), points with associated symbols (i.e., airports), text features (e.g., city names), and areas (i.e., shaded metropolitan areas) (p. 44)." Vector maps can also be modified on the fly by adding symbology and objects not originally found on the map. It was concluded by [59] that the advantages vector maps had over digitally scanned maps were numerous. Of note "virtually all helicopter pilots gave all three capabilities (keeping text upright, selectively de-cluttering, and adding detail) the highest possible rating (extremely useful) [p. 45, sect. 4.6.2].

Map sources should include all navigational charts (including Digital Aeronautical Flight Information File (DAFIF) data) and tactical charts currently available to aircrew. In addition, satellite imagery should be included to capture areas not covered by existing charts. A hybrid between both types of maps would be ideal in order to provide the pilot with the maximum amount of geographical data available. The hybrid feature found on many on-line mapping tools such as MapQuest © and Google Earth © provide

excellent examples of this concept. These functional requirements are outlined in section 4.3.9 of [30]:

Moving-map shall be capable of pre-flight loading and in-flight display of National Geospatial-Intelligence Agency (NGA) raster product format data and vector data that incorporates and overlays geo-referenced navigation and waypoint/flight data onto a common map background.

The MFD moving map design described above has many traits in common with the current DMK implementation. This follows as much of the functional requirements of a MFD integrated moving map are found in the DMK. Thus, in keeping with the philosophy of leveraging existing "engineering experiences [6, p. 26]" when developing new designs, the DMK interface will be used as a basis. The reader should keep in mind that interview complaints about the DMK had more to do with the kneeboard implementation than the actual interface. That said, a one-for-one copy of the DMK interface is not the solution. A more specific interview on the likes and dislikes of the DMK interface should be conducted to eliminate the wheat from the chaff and identify any interface issues.

Inclusion of the DMK interface in the design concept also brings in to play FalconView®. Just like the reuse of DMK in order to leverage existing aircrew training, this system will be based on FalconView® and Portable Flight Planning Software (PFPS) commonly in use throughout military aviation. FalconView®:

Is a non-proprietary GOTS (Government Off-The-Shelf) application for analyzing and displaying geographical data crucial to the warfighter. Its ease of use and wide variety of applications have

made it the system of choice for the warfighter and the standard for data interchange in Iraq and Afghanistan. [60, p. 1]

The primary benefit of FalconView© is it "supports a robust set of programmer interfaces, which allow diverse applications to fuse their information into a single coherent picture of the user's area of interest [60, p. 2]." Areas of interest could include a benign flight across the United States or a more hostile flight in to enemy territory. Either way it is captured. The ability to port this data directly to a moving map display is extremely useful and is without doubt the primary motivation behind its usage on the DMK. Using FalconView © is also in keeping with the spirit of incorporating "evolutionary—as opposed to revolutionary [51] changes in the cockpit.

One major issue with integrating FalconView© into the MFD moving map solution is the question of in-flight planning. Since the DMK is a fully functioning native Windows XP© operating environment, there is a one-to-one mapping of FalconView© usability from the PFPS laptops in the squadron to the DMK in the aircraft. The operating environment and user interface devices in the common cockpit are significantly different and present a challenge to the functionality of in-flight user updates. Although this functionality was not specifically identified in the MH-60S ORD, it is an issue that must be addressed. The primary issue is therefore whether a technical limitation exists in the cockpit environment that would prevent all of the FalconView© flight planning functionality from being available. This would warrant a closer examination and is beyond the scope of this thesis. To that end the assumption

will be made that at least limited flight planning functionality is available in the MFD moving map design as detailed in the existing functional requirements from section 4.6.7 in which the system shall "provide the ability to manipulate these waypoints/flight plans in flight."

b. 3D ERF FLIR

A more radical design departure from the current common cockpit convention would be the integration of a pseudo 3D ERF display to assist the non-flying pilot with Geo-positional situational awareness. This design would be pseudo in the fact that true 3D would be technically limited in the current common cockpit. The goal is to attempt to capture a more ego-referenced display since "(ego referenced) maps support better navigation performance, as these tend to both to alleviate mental rotation and provide a left-right display frame of reference that is compatible and congruent with the frame of reference of the control" [13, p. 113].

A true 3D ego-centric ERF display would most likely involve the projection of a 3D environment on some type of heads-up display, as described in [12]. Acknowledging realistic technical limitations, the goal of this ERF implementation would be to assist the non-flying pilot with navigational reference under the assumption that he or she would be "backing up" the flying pilot as is often the case in high workload cockpit environments.

The operating environment for this implementation would be in a tactical situation in which local guidance is the preferred means of navigation as outlined in [59]. Such missions include NVD Nap-of-the-Earth (NOE) flights, as well as overwater surveillance missions.

The design would superimpose current HUD symbology found on the NVD kit to the MFD FLIR image. The FLIR image data would provide the ego-centric view found associated with a 3D ERF while the HUD projection would help the non-flying pilot reference the current condition of the aircraft. This display would thus provide both ge-positional data as well as aircraft status in one glance. The reason this data would be designed for the non-flying pilot is that the majority of the viewing is done while scanning inside the aircraft (MFD scan) and not outside as is the case for tactical environments.

The inclusion of this functionality has the added benefit of including both the ERF and WRF perspectives. As discussed in [12] and [13], this is the ideal solution.

4. Symbology and Color Scheme

The Department of Defense Interface Standard-Aircraft Display Symbology (MIL-STD-1787C) is the standard for display symbology throughout the Department of Defense. It:

Defines the symbology requirements for a primary flight reference and describes some fundamental relationships between symbol motion and aircraft system states. It describes symbols, symbol formats, and information content for electro-optical displays that provide aircrew members with information for takeoff, navigation, terrain

following/terrain avoidance, weapon delivery, and landing. It also provides (in appendixes) non-binding information on symbolgy, geometry, fonts, recommended dimensions, and mechanizations. [61, p. 1]

Given the depth and breadth of this document, the design team will use it as the standard for display symbology.

C. RECOMMENDATIONS

The intended scope of this thesis is an examination of the Common Cockpit associated with the MH-60S and MH-60R and recommendations on the improvement of that program will be made. Some of these recommendations, however, are more broad-based and applicable to the entire defense acquisitions process outlined in [62], as it relates to glass-cockpit design. Recommendations are thus divided into these two categories.

1. Common Cockpit Recommendations

The author is keenly aware that in reality the chance of a complete redesign of the Common Cockpit due to cost alone is slim. In relation to "trade-offs" with the current common cockpit, cost would seem the only issue as the basic technological requirements are already in place. Realistic recommendations are thus:

Implement a moving map: Nine of nine pilots interviewed said an integrated MFD moving map would greatly improve geo-spatial situational awareness during every aspect of flight regardless of mission. NAVAIR as well recognized this fact and developed the practically useless DMK as noted earlier.

Considering the positive impact a truly MFD integrated moving map would have, NAVAIR should expedite this design well ahead of the current plan to field it in 2016, assuming it gets funded [35]. It should be noted that Lockheed Martin, as a result of the IRAD discussed above, has already developed a prototype moving map that integrates graphical map overlays (navigational maps, etc.) with the existing NTDS style symbology found in the current Common Cockpit.

Reprogram the Common Cockpit: Elevate the Common Cockpit program to an Acquisitions Category (ACAT) instead of its current 845 status. This will help ensure requirements are clearly stated and allow better management of costs and funding.

2. Defense Acquisitions Recommendations

Implement Crew Centered Design in the DoD acquisitions process: In today's modern computer centric aircraft, reliability of the aircraft as a system is rapidly being overshadowed by usability as the number one design issue. Appendix eight of [62] clearly recognizes this shift and states the Program Manager of a DoD acquisitions program:

Shall have a plan for [Human Systems Integration (HSI)] in place early in the acquisition process to optimize total system performance, minimize total ownership costs, and ensure that the system is built to accommodate the characteristics of the user population that will operate, maintain, and support the system. [p. 60]

Enclosure eight continues by discussing a broad range of issues including training and survivability. Although necessary at a high level, this broad-brush approach to HSI is insufficient when dealing with cockpit design, as

evidenced by the Common Cockpit. Given the complexity of the modern cockpit, associated pilot workload and the uniqueness of the cockpit operating environment, a very specific methodology must be outlined to address its design and implementation. To this end [62] should specifically name Crew Centered Design as the sole method of manned cockpit design.

Refine ORDs to be as specific as possible to reflect user needs: Ensure that Operation Requirements Documents (ORD) or Initial Capabilities Documents (ICD) as described in [62] are written as clear and concise as possible. Functional requirements should be justified via sound scientific methods and well understood by the Program Manager. Acquisitions professionals should understand that the contractor is bound by the contract to provide what is asked for, not necessarily what is needed.

Combine efforts across DoD to produce a truly Common Cockpit: Expand the notion of cross platform cockpit commonality by following the example of the U.S. Army's Common Avionics Architecture System (CAAS), in which the same basic cockpit architecture is used in the Army's extensive fleet of dissimilar rotary-wing aircraft. By combining resources and leveraging the existing development experience, the Navy can make the next generation of Common Cockpit truly common by employing it across all new Navy/Marine Corps rotary-wing aircraft. This is not to say there will not be differences between cockpits, but it is an acknowledgement that the fundamentals of *aviate*, *navigate*, *communicate* are common functional requirements of any cockpit.

Examine the integration of Human System Integration across all acquisitions projects that have human-machine interactions: Although this thesis is specific to the Common Cockpit, this issue is just one example of the much broader issue of usability across all human-machine interaction. HSI applies as much to cockpits as it does to any type of device that requires direct human interaction. In fact, the fundamental usability of a cockpit is not that much different than that of a door handle: the design must be usable or it will not get used. Through the use of methodologies such as CCD briefly described in this thesis, the acquisitions process must seek proven and effective ways to integrate HSI with existing industry design practices and standards for the HSI requirements of [62] to become truly effective.

D. FUTURE WORK

During the interview conducted in San Diego, respondents identified two potential areas of research in to Common Cockpit shortcoming. These include:

- Two interview subjects recommended the integration of a Flight Management System for improved airway navigation. An example of this is Sikorsky's glass cockpit solution and with an integrated FMS 800 [63].
- Five of nine interview subjects indicated dissatisfaction with the several aspects of the Forward Looking Infrared (FLIR) implementation to include image display size and the usefulness of the

Hand Control Unit (HCU). Further exploration in this direction is warranted.

- Four of nine pilots interviewed expressed some level of dissatisfaction with the current PKI / FFK layout and menu depth associated with these keys. Further exploration in to the usability of the current setup against the guidelines established in NAWCADPAX "Situational Awareness Guidelines."
- Explore the possibility of an ego-centric 3D augmented reality HUD for the Common Cockpit.

THIS PAGE INTENTIONALLY LEFT BLANK

APPENDIX A: INTERVIEW RESULTS SUMMARY

Nine subjects were interviewed over a three-day period. Although scheduled to last one half of an hour, the interviews lasted on average an hour. A summary of questions asked in Appendix A are provided below.

A. SUMMARY STATISTICS

- Total hours (median): 1300
- Total MH-60S hours (median): 1000
- Total previous qualified Helicopter in a different series: 2

B. QUESTION SUMMARIES

The following represents a summary of the questions asked during the interview process. Although some themes were common throughout the interviews, some subjects brought out unique ideas and observations.

1. What MH-60S missions are you most familiar with? (SAR, LOG, MEDEVAC, etc.):

All the subjects were familiar with the basic FRS missions, including Search and Rescue (SAR), Logistics (LOG), and basic flight familiarity training (FAM). All were also familiar with Armed Helo mission (TACTICS), although the experience level varied from entry level to advanced.

2. **Given your experience in the above missions you highlighted, tell me about instances for which you may have experienced difficulties with the cockpit interface while conducting those missions:**

A wide variety of issues were presented. Concepts are grouped below:

- Multifunction Display (MFD) readability: Initial boot contrast defaults to the lowest setting thus requiring the user to adjust contrast to a higher setting to be readable. Also, several magenta colored displays (needles and heading settings) were not readable, particularly on the edges of the viewing area.
- Forward Looking Infrared (FLIR) Hand Control Unit (HCU):
- What are your general likes and dislikes with the cockpit interface?
- Likes
- The joystick interface pointing device was mentioned as effective. However, the variable rate in which scroll rate is somewhat proportional to joystick displacement took practice to master.
- Dislikes
- Layered menus were almost universally mentioned as an issue. Specifically mentioned was the three step process of switching the IFF transponder from "Transmit" to "Standby."

3. **Are there any other MH-60S interface issues that you would like to describe or may be relevant to this study?**

This question almost completely revolved around the elimination of the current kneeboard implementation of the moving map functionality and replacing it with an integrated moving map display in the Mission Display (MD).

4. **Finally, if there was something you could change about the cockpit, what would it be?**

By the end of the interview process, this question was both asked and answered as a result of discussions from questions c and d above. However, a few subjects mentioned other items not previously discussed during their interview, including the need for more comfortable pilot seats, better visibility from the cockpit, and unified helmet cord that integrates Internal Communications Systems (ICS) and all Night Vision Device (NVD) functionality. Also mentioned was changing the airspeed indication tape to a more readable format and a way for aircrewmembers to monitor aircraft altitude in low-level situations.

THIS PAGE INTENTIONALLY LEFT BLANK

APPENDIX B: RAW INTERVIEW DATA

TABLE OF CONTENTS

| | | |
|-----|-------------------------------------|---|
| I. | INTRODUCTION..... | 1 |
| A. | PURPOSE OF THE STUDY INTERVIEW..... | 1 |
| B. | DURATION..... | 1 |
| C. | PROCEDURE..... | 1 |
| | Environment..... | 1 |
| | Interview Process..... | 1 |
| II. | INTERVIEW DATA COLLECTION..... | 3 |
| A. | FLIGHT EXPERIENCE..... | 3 |
| B. | QUESTIONS..... | 3 |

THIS PAGE INTENTIONALLY LEFT BLANK

Once the interview is complete, the interviewer will thank the participant for his or her time and ask if there are any follow-on questions.

II. INTERVIEW DATA COLLECTION

A. FLIGHT EXPERIENCE

1. Total hours: 275
2. Total hours (MH-60S): 100
3. Previous model qualified HAC?: No, not HAC

B. QUESTIONS

1. What MH-60S missions are you most familiar with (SAR, LOG, MEDEVAC, etc):

RP - SAR, NSW, Fam

2. Given your experience in the above missions you highlighted, tell me about instances for which you may have experienced difficulties with the cockpit interface while conducting those missions:

- TACT page replaced with moving map. Need references to cross check, keep pattern safe
- Navigation - GPS waypoints / GPS flight plan - like RNAV

3. What are your general likes and dislikes with the cockpit interface?

Likes:

- HSI modes (MAP, etc)
- Good size of HSI / AH ratio

Dislikes:

- No integrated NAV GPS for airway navigation

4. Are there any other MH-60S interface issues that you would like to describe or may be relevant to this study?

- NP/NR IQ on different displays
- De select fuel on display but set a fuel "burst" like setting a DH.
- More audible tones for Fire / Engine out

5. Finally, if there was something you could change about the cockpit, what would it be?

- Better visibility through the floor
- One cord for everything vice goggles /

- Eliminate xponder to STBY key-structures
- Mount Map display - Put on main display
 - Why not incorporated into mission display?
 - Why not xfer functionality of kneeboard display to Mission Display?
- Map orientation
 - Always like north up (either chart or digital display).
 - Integrated GPS approaches / flight data
- What is the justification
- FCR Control unit is flawed
 - both seats need to have it like the Romeo

II. INTERVIEW DATA COLLECTION

A. FLIGHT EXPERIENCE

1. Total hours: 1250
2. Total hours (MH-60S): 1000
3. Previous model qualified HAC?: NO

B. QUESTIONS

1. What MH-60S missions are you most familiar with (SAR, LOG, MEDEVAC, etc):

SAR, MEDEVAC / LOGS, FAM, TACTICS

2. Given your experience in the above missions you highlighted, tell me about instances for which you may have experienced difficulties with the cockpit interface while conducting those missions:

ACU For FLIR - Controller is hard to manipulate, must manipulate buttons and stick as well. It is a 2 handed job. Only on left side. Make it more like Xbox controller.

3. What are your general likes and dislikes with the cockpit interface?

Likes: Color readout for indications

Dislikes:

- FLIR Controller
- PKI
- No moving map
- Small PCMCIA card capacity - could it be brick size

4. Are there any other MH-60S interface issues that you would like to describe or may be relevant to this study?

- Moving map is the most glaring error in the airplane
- Integrated DFR charts / GPS approaches
- FLIR design seems "hasty"

5. Finally, if there was something you could change about the cockpit, what would it be?

- Make AIS gauge a needle vial
digits - make it a rate gauge. Current
sliding scale doesn't work
- HUD turn display confusing

- Wings level λ looks more like now 0°
- Horizon and wings are same color. Perhaps should be the same.
- Air Speed indicator
 - Tape display not very useful / digital readout causes trouble - why are they not analog
- WCA
 - Caution light comes on too often
 - Integrate caution lights on FD
- MD
 - FLIR - when switching to FLIR from normal MD contrast setting is too much.
 - Auto turn coordination in a couple of hours above 50 kts
 - Seemed to spend more time looking at glass cockpit
 - Ball on FD - not really visible
 - Overlay TACT screen with mount map
 - Bigger FLIR picture

II. INTERVIEW DATA COLLECTION

A. FLIGHT EXPERIENCE

1. Total hours: 1300
2. Total hours (MH-60S): 1000
3. Previous model qualified HAC?: NO

B. QUESTIONS

1. What MH-60S missions are you most familiar with (SAR, LOG, MEDEVAC, etc):

Armed Helo, FAMS (Night), SAR, ADRAMS

2. Given your experience in the above missions you highlighted, tell me about instances for which you may have experienced difficulties with the cockpit interface while conducting those missions:

- Numbers on Moxika are not readable in the corner
- FUEL display too small should be bigger picture with better resolution
- Letters now grouped by 3's, duplicated FFTs with PHIS

3. What are your general likes and dislikes with the cockpit interface?

Likes: Colors for warnings / cautions

Fuel Colors ³

- Display size, location of instruments, lat/long on WCA screen, hover / map mode of cyclic
- Radio switches 'on' collective

Dislikes: Non-visibility Colors

- Not enough radios - one more of integrate
- Scan capability from RCU to cockpit radio
- Center consoles not standardized in blocks

4. Are there any other MH-60S interface issues that you would like to describe or may be relevant to this study?

- Wet compass no visible from left seat
- Back-up instruments not very functional
- Bull lighting control
- Reverse RCU so looking top down

5. Finally, if there was something you could change about the cockpit, what would it be?

- Smaller glare shield

- Moved SAR keys around
- Splitfire Engine vials in left seat
- Limit fuel picture to just numbers
- AFCS cubes / More master caution on main display
- Fire light integrated in to main display
- More aural warning for EPs (engine out, fire, etc).
- Moving map - looking like Falcon view
- Keyboard map not used as it is too much stuff
- Integrated GPS
- FLIR - too many safeties to use FLIR, buttons too far apart
 - Can eliminate steps here or have FLIR figure it out
- SAR - put depart light on screen instead of AFCS cube
- BAR ACT knob - more buttons to where the knob is.

II. INTERVIEW DATA COLLECTION

A. FLIGHT EXPERIENCE

1. Total hours: 1370
2. Total hours (MH-60S): 750⁶⁰
3. Previous model qualified HAC?: F/H

B. QUESTIONS

1. What MH-60S missions are you most familiar with (SAR, LOG, MEDEVAC, etc):

Armed Helo

2. Given your experience in the above missions you highlighted, tell me about instances for which you may have experienced difficulties with the cockpit interface while conducting those missions:

When using fuel and error develops (weapons, etc) must exit fuel mode, go to ord control, re-inventory stores, must turn off all power to system, close symbols, then attempt to re-inventory stores and repeat the process - done for safety

3. What are your general likes and dislikes with the cockpit interface?

Likes:

- how the gauges limit change (Q) for different flight regime - why³ doesn't transmission pressure change?
- FLIR image on both MDS (left/right).

Dislikes:

- FSR image too small should be bigger (full screen)
- when FSR is up, heading is presented in TRUE, should be MAG.
- Left/Right side gauges display are different
- Engine mtds not grouped together (NG, TGT)

4. Are there any other MH-60S interface issues that you would like to describe or may be relevant to this study?

- HCU for FSR is "ergonomically clunky". Trying to do 3 things with same hand - L/R, hold retreat or target, keep laging.

5. Finally, if there was something you could change about the cockpit, what would it be?

- Allow crewman to select emergency (IFF, Guard) and a display to monitor altitude. (MFD)
- HCU should be like a gear controller, this HCU was also used in F/A as well (legacy gear).

2(Cnt) Should be able to override and ~~activate~~
another weapon.

- FLIR system is overly safe - laser always
goes into safe mode. Like car turning itself
off every time at stoplight

- TACT display has no mag - why not? Converting
MAG VAR is difficult

- Declutter

- Get rid of some redundant displays
and leave black space

- STBY instruments not usable, more and
replace with another display that does
checklists

- NVG HUD very difficult to use. When head rolls
left or right so does AH.

- GPS approaches!

* Cockpit is about as distracting and complex as
you want it to be!

- Moving map - at least level of functionality
would use all the time.

- never use kneeboard - too bulky

Touch draw

II. INTERVIEW DATA COLLECTION

A. FLIGHT EXPERIENCE

1. Total hours: 1450
2. Total hours (MH-60S): 1200
3. Previous model qualified HAC?: No

B. QUESTIONS

1. What MH-60S missions are you most familiar with (SAR, LOG, MEDEVAC, etc):

SAR, LOG, NATOPS

2. Given your experience in the above missions you highlighted, tell me about instances for which you may have experienced difficulties with the cockpit interface while conducting those missions:

SAR - Complex Hover - DH is not paired to set alt once moved from initial position.

- Why are all headings true and not magnetic? Should be in magnetic

- When SAR pattern is plugged in, does not revert to hold

3. What are your general likes and dislikes with the cockpit interface?

Likes:

Dislikes:

When software changes, multiple hoiset
layers changed

4. Are there any other MH-60S interface issues that you would like to describe or may be relevant to this study?

- PMCIAS are hard to use, can we set the boards to a default setting independent of cards?

5. Finally, if there was something you could change about the cockpit, what would it be?

→ Setup boards to default PMCIAS settings.

2. (Cont) Color change for 1st main wings
- get rid of 1st

- Moving Map - need of for SA into Mexico
 - consume whole screen just like TACMAN
 - Look just like Falcon View, would also reduce reliance on paper charts
- If map on flight display does not detract from scan pattern
- knee board maps not used by pilots - Bulky, in the way, detract from scan pattern, no added value for normal flying around

II. INTERVIEW DATA COLLECTION

A. FLIGHT EXPERIENCE

1. Total hours: 1350 → 1550
2. Total hours (MH-60S):
3. Previous model qualified HAC?: No

B. QUESTIONS

1. What MH-60S missions are you most familiar with (SAR, LOG, MEDEVAC, etc):

ARMED HELO of OVERLAND (TERP), FAMS, SAR

FLDR - Dunge only covers 1/3 screen instead of entire screen as in legacy system (HH-60H system)

Armed Helo
MATIP

2. Given your experience in the above missions you highlighted, tell me about instances for which you may have experienced difficulties with the cockpit interface while conducting those missions:

FLDR hand control only on right side w/S out on both side of R / Potato handle

- Missile Firing 3 or 4 layers deep

- Digital Map kneeboard - pilots don't use since it is in the way
Interface from kneeboard to display bypasses MAP

DMSH
Digital map
function unit

3. What are your general likes and dislikes with the cockpit interface?

Likes:

Dislikes: Display w/ FLIR, lack of interface, small FLIR interface
Moving map would replace everything on TACT bezel key

4. Are there any other MH-60S interface issues that you would like to describe or may be relevant to this study?

FLIR screen way too small - bigger screen would be easier to pick out targets.

5. Finally, if there was something you could change about the cockpit, what would it be?

Direct Falcon view to screen - full color

- Add 5th screen to replace backup instruments
(H-60 m/L use as example)
- DMR is touchscreen, why not main displays
- Missile shot via "remote designation" - lots of steps -
augmented help would fix this. - Geometry very complicated
- Army procurement for 60 vice Navy for 60.

II. INTERVIEW DATA COLLECTION

A. FLIGHT EXPERIENCE

1. Total hours: 1700
2. Total hours (MH-60S): 1000
3. Previous model qualified HAC?: No

B. QUESTIONS

1. What MH-60S missions are you most familiar with (SAR, LOG, MEDEVAC, etc):

LOG, SAR, FAMS, MUD, Nite, Instruments

2. Given your experience in the above missions you highlighted, tell me about instances for which you may have experienced difficulties with the cockpit interface while conducting those missions:

PHE - now has a "TA" input. Slows down operations
- Arrow key pad on PHE duplicates FFK

SAR - FFK for SAR patterns
- only gives daytime SAR
- Integrate SAR TACED info into pattern corrections
- MCG Data not included

3. What are your general likes and dislikes with the cockpit interface?

Likes:

- Prioritizes Cautions on the MFD
- Emergency button does lots of stuff
- TUNE keys
- Cycle through HSI modes via cyclic
- Radio toggle switch on cyclic

- Dislikes:
- Backup instruments location - bad scan pattern
 - MVD HUD
 - Buried menu items
 - Depart button on cyclic, too close to emergency release

4. Are there any other MH-60S interface issues that you would like to describe or may be relevant to this study?

- Need 3rd Radio

5. Finally, if there was something you could change about the cockpit, what would it be?

Need better visibility outside

- GPS last approaches / procedures / modifications
- Eliminate PNCIA Cards / Go to USB std.
- Moving map
 - Option to change views
 - Ego, exo, 2D Planar view
 - Can outline major geographical items in TACT view
 - Add moving map to center console where B/U instruments are now.
- Easy to get lost in Radio menu
 - V/UHF Control key, PHIS pretty much stays the same but a few new keys are added
- Helo seems to get vertigo more due to reflection of displays on to cockpit glass.
- Need MAG / TRUE option on TACT display - Everything is in MAG
- Better way to drop a datum on the map

II. INTERVIEW DATA COLLECTION

A. FLIGHT EXPERIENCE

1. Total hours: 1200
2. Total hours (MH-60S): 30
3. Previous model qualified HAC?: H-60 F/H

B. QUESTIONS

1. What MH-60S missions are you most familiar with (SAR, LOG, MEDEVAC, etc):

FAM / Armed Helo

2. Given your experience in the above missions you highlighted, tell me about instances for which you may have experienced difficulties with the cockpit interface while conducting those missions:

- Menus deep and convoluted - Trying to remember how to load chaff / flares
- Know where helo is in relationship to a lot / long
- Long startup time just to enter data.
- TACAN track function in H not exists in H

3. What are your general likes and dislikes with the cockpit interface?

Likes:

More FLIR options: Daytime TV, Color

Dislikes:

- FDR does not fill up entire screen. Not resolution issue.
- FDR Hand Control unit only on left side, should be both plus not very usable.
-

4. Are there any other MH-60S interface issues that you would like to describe or may be relevant to this study?

- kneeboard is awkward -
- Blue force Tracker integration w/ moving map?
- Integrated GPS Flight Management System
- * Falconview w/ GPS - big transition problem going *
from black GPS screen to printed map

5. Finally, if there was something you could change about the cockpit, what would it be?

- Switches between blocks are different spots. dislike center wind screen since it has no way to clean

- Tracking - Air to Air Taccon except w/ ship
- Moving map on kneeboard: cumbersome, have to scan down to tree, scan pattern issue, head down to heads up
- 2D planar view is preferred
- Eliminate center b/w instruments replace w/ MFD
- Engine instruments across 2 different MFDs, put together
- WCAs easy to ignore.
- De clutter Flight Display
- Eliminate multiple ways to get to certain functions
- Clear up PHI pages, multiple ways to get around
- Everything is MVD compatible

II. INTERVIEW DATA COLLECTION

A. FLIGHT EXPERIENCE

1. Total hours: 1300
2. Total hours (MH-60S): 900
3. Previous model qualified HAC?: No

B. QUESTIONS

1. What MH-60S missions are you most familiar with (SAR, LOG, MEDEVAC, etc):

SAR, LOG, TACTICS (Armed Helo)

2. Given your experience in the above missions you highlighted, tell me about instances for which you may have experienced difficulties with the cockpit interface while conducting those missions:

- When booting up, MO always boots up in lowest contrast (particularly with radios) - needs to be higher by default (Except with FLIR).

3. What are your general likes and dislikes with the cockpit interface?

Likes:

- Joystick for controlling pointer

Dislikes:

Layered menus for frequently used items.

4. Are there any other MH-60S interface issues that you would like to describe or may be relevant to this study?

- Keyboard display is a POS

5. Finally, if there was something you could change about the cockpit, what would it be?

- Better seats - uncomfortable

LIST OF REFERENCES

- [1] GlobalSecurity.org, CH-46 sea knight. Retrieved December 3, 2008, from http://www.globalsecurity.org/military/systems/aircraft/images/ch-46_020914-n-3986d-001.jpg.
- [2] GlobalSecurity.org (December, 2004), MH-60S. Retrieved December 3, 2008, from <http://www.globalsecurity.org/military/systems/aircraft/ch-60-pics.htm.Last>.
- [3] Wikimedia.org, "U.S. Navy Helo Master Plan." Retrieved December 3, 2008, from http://commons.wikimedia.org/wiki/Image:US_Navy_Helo_Master_Plan.jpg
- [4] M. Fuqua, F. Pagano, D. Osterlund, C. Deitchman and B. Reuter, "Navy Helo Master Plan—A View from OPNAV," *Rotor Review*, Summer 1996.
- [5] Naval Air Systems Command, "NATOPS Flight Manual Navy Model MH-60S Aircraft," March 15, 2005.
- [6] Lockheed Martin, "Process Guidance Series - Systems Engineering: Human-Computer Interface Requirements (HCIRS)," March 20, 1998.
- [7] W. A. McConvey, "MH-60S Armed Helo: Upgraded Capability to a U.S. Navy Workhorse Helicopter," *Aerospace Conference, 2007 IEEE*, pp. 1-13, 2007.
- [8] J. Tomasic, "MH-60S Armed Helicopter Critical Design Review—DMS PDR," NAVAIR, January 25-27, 2005.
- [9] Office of the Under Secretary of Defense (Acquisitions and Technology). (February 5, 1996). DoD Guide to integrated product and process development. *Version 1.0*
- [10] Michael T. Palmer, William H. Rogers, Hayes N. Press, Kara A. Latorella and Terence S. Abbott, "A crew-centered flight deck design philosophy for high-speed civil transport (HSCT) aircraft," NASA Langley Technical Report Server, 1995.

- [11] Lockheed Martin, "Human engineering design approach document-operator," Tech. Rep. 6953785K, November 10, 2006.
- [12] D. Foyle, A. Adnre and B. Hooey, "Situation awareness in an augmented reality cockpit: Design, viewpoints and cognitive glue," Proceedings of the 11th International Conference on Human Computer Interaction, Las Vegas, NV, 2005.
- [13] C. Wickens and P. Tyler, "Exploring the dimensions of egocentricity in aircraft navigation displays," *Journal of Experimental Psychology: Applied*, vol. 1, p. 110, 1995.
- [14] Airforce-Technology.com, (2008, MH-60S Knighthawk multi-mission naval helicopter, USA. 2008(12/3), p. 1.
- [15] A. Fink, "How to Conduct Surveys : A Step-by-Step Guide," p. 109, 2006.
- [16] Airbus, (October, 2004). Flight operations briefing notes-human performance-managing interruptions and distractions. Retrieved February 2, 2009, from <http://www.skybrary.aero/bookshelf/books/176.pdf>.
- [17] C. L. Culver, "Optimally scheduling distribution of the MH-60s helicopter and pilots to combat support (HC) squadrons," p. 67, March 2002.
- [18] T. E. Laux, A. L. Winns and S. T. Helland. (2004, March 4,, 2004). Statement of Mr. Thomas E. Laux program executive officer air ASW, assault & special mission programs and Rear Admiral Anthony L. Winns, United States Navy Deputy Director of Air Warfare (N-78B) and Brigadier General Samuel T. Helland, United States Marine Corps Assistant Deputy Commandant for Aviation Headquarters, U.S. Marine Corps before the Subcommittee on Tactical Air and Land Forces of the House Armed Services Committee on the Department of the Navy Rotorcraft Programs and Future Technology Initiatives and Concerns.
- [19] H. C. Jackson, "The USMC Medium-Lift Replacement Dilema," *Marine Corps University Command and Staff College*, 1992.

- [20] Inside the Army, "Sikorsky Shops Multi-Service Black Hawk Idea to Army, Pentagon Leaders," *Inside the Army*, October 2, 1995.
- [21] T. Terella-Faram, "OSD Discusses Options for Restoring Funding for Army Black Hawk Buys," *Inside the Army*, July 15, 1996.
- [22] Inside the Navy, "Marine Corps UH-1N Upgrade Plan Snarled in OSD, Army UH-60 Imbroglia," *Inside the Navy*, July 29, 1996.
- [23] E. M. Grossman, "OSD Threatens to Move Army Black Hawk Funds to Marine Corps, Navy," *Inside the Pentagon*, December 12, 1996.
- [24] S. W. Kandebo, "Navy Helo Goals Hinge On CH-60 Demonstrator," *Aviation Week & Space Technology*, vol. 145, p. 20, October 28, 1996.
- [25] Peters, Dean CAPT PMA 299, "Acquisition strategy report (ASR): MH-60S master acquisition plan (MMAP) of November 9, 2002," Tech. Rep. 299-2008-08-26-R1, November 9, 2002.
- [26] Defense Daily, "Ch-60 Makes Maiden Flight," *Defense Daily*, vol. 197, p. 1, October 7, 1997.
- [27] Defense Daily, "Defense Contracts," *Defense Daily*, vol. 203, p. 1, September 20, 1999.
- [28] Director, Operational Test & Evaluation, "Director, operational test & evaluation FY98 annual report," 1998.
- [29] Rotor Review, "CH-60S First Flight," *Rotor Review*, vol. Winter 2000, p. 27.
- [30] Department of the Navy, "Operational requirements document (ORD)-change two-for the multi-mission combat support (HSC) helicopter," Tech. Rep. 741-88-08, February 25, 2008.
- [31] Committee On Appropriations, "Department Of Defense, Appropriations Bill, 2003, Report Of The Committee On Appropriations [To Accompany H.R. 5010] together with additional views," Tech. Rep. 107-532, June 25, 2002.

- [32] Office of the Under Secretary of Defense for Acquisition, Technology and Logistics, "Other transactions" (OT) guide for prototype projects," January 2001.
- [33] Defense Daily, "Lockheed Martin Awarded \$423 Million MYP Contract For MH-60S, MH- 60R Cockpits," *Defense Daily*, vol. 221, p. 1, January 6, 2004.
- [34] Director, Operational Test & Evaluation. (2003), "FY2003 Report for the Office of the Director, Operational Test & Evaluation."
- [35] M. Harman. Common Cockpit Funding Discussion. E-mail conversation concerning the common cockpit funding and requirements document. December 8, 2008.
- [36] M. Kracik, "Common cockpit Questions," vol. A spun off thread from Mike Harman about the Common Cockpit, December 8, 2008.
- [37] M. Matarozza. (February 1, 2005). Product focus: Moving maps new connections. *Avionics Magazine*. Retrieved January 22, 2009, from <http://www.aviationtoday.com/av/categories/military/737.html>.
- [38] C. Collins. Discussions on moving map implementations. *Email discussing Lockheed Martin's IRAD for a moving map in the Common Cockpit*. November 17, 2008
- [39] Naval Research Lab Stennis Space Center MS Marine Geosciences Div, M. Lohrenz, M. Trenchard and S. Edwards, "An on-line evaluation of cockpit moving-map displays to enhance situation awareness in anti-submarine warfare and mine countermeasures operations," May 31, 2001.
- [40] Naval Research Lab Stennis Space Center MS Mapping Sciences Section, M. Lohrenz, Trenchard, Michael and S. Edwards. (2002), A pilot-centered evaluation of geospatial data for proposed navy helicopter moving-map displays. *American Association for Artificial Intelligence*. Retrieved February 2, 2009, from <http://mmc.nrlssc.navy.mil/publications/public/Lohrenz-HCIAero-02.pdf>.

- [41] T. Feeney. E-mail between Tim Feeney and Peter Corrao. *Discussion on the limitations of the FMC and MC IRT moving map technology*. November 10, 2008.
- [42] S. W. Carson. Discussion on moving map limitations and the FMC. November 10, 2008.
- [43] C. Collins. Discussion of common cockpit design methodology. *Email between C. Collins and P. Corrao concerning the description of the MH-60S Common Cockpit design methodology*. October 9, 2008.
- [44] J. D'Arcy, Discussion on Lockheed Martin HCI Design Process. Email between P. Corrao and Dr. D'Arcy, March 26, 2008.
- [45] T. Feeney. Discussion on the design of the DMK. Email between T. Feeney and P. Corrao, January 27, 2009.
- [46] K. Dismukes, G. Young and R. Sumwalt. (1998, Cockpit interruptions and distractions. *ASRS Directline (10)*. Retrieved February 2, 2009, from http://asrs.arc.nasa.gov/publications/directline/dl10_distract.htm.
- [47] Naval Research Lab Stennis Space Center MS Marine Geosciences Div, M. Lohrenz, M. Trenchard and S. Edwards, "An on-line evaluation of cockpit moving-map displays to enhance situation awareness in anti-submarine warfare and mine countermeasures operations," May 31, 2001.
- [48] Naval Air Warfare Center Aircraft Div Patuxent River Md, K. T. Garner and T. J. Assenmacher, "Situational awareness guidelines," January 8, 1997.
- [49] W. McConvey. Discussion as to why the DMK was the moving map solution. Email between W. McConvey and P. Corrao, January 28, 2009.
- [50] M. Stollings and J. Amell, "Crew centered cockpit methodology," 1992 Aerospace Design Conference, Irvine, CA, 1992.

- [51] J. Veitengruber and W. Rankin. Use of crew-centered design philosophy allows the introduction of new capabilities and technology. *ICAO Journal*, March 1995. Retrieved February 28, 2009 from http://www.icao.int/anb/humanfactors/Use_of_crew_1995.pdf.
- [52] M. Clamann and D. B. Kaber. (January 1, 2004). Applicability of usability evaluation techniques to aviation systems. *International Journal of Aviation Psychology* 14(4), pp. 395-420. Retrieved February 28, 2009, from http://dx.doi.org/10.1207/s15327108ijap1404_4.
- [53] C. D. Wickens, S. E. Gordon and Y. Liu, *An Introduction to Human Factors Engineering*, 2nd ed. Upper Saddle River, N.J: Pearson Prentice Hall, 2004, p. 587.
- [54] Wikipedia. (December 3, 2008). Global air traffic management. Retrieved December 3, 2008, from http://en.wikipedia.org/wiki/Global_Air_Traffic_Management.
- [55] C. Adams. GATM-izing galaxy: New C-5 avionics. *Avionics Magazine*, February 1, 2004. Retrieved March 3, 2009, from <http://www.aviationtoday.com/av/categories/military/724.html>.
- [56] S. C. McPhail, "MMH controls and displays (CAD) design analysis report," June 1, 1998.
- [57] J. Boyd, T. Butash, W. Grizzle and R. Taylor, "LAMPS MK III block II simulation for advanced algorithm development," *Digital Avionics Systems Conference, 1994. 13th DASC*, AIAA/IEEE, pp. 198-205, 1994.
- [58] Department of Defense, "Department of Defense Architecture Framework, Version 1.0-Volume I: Definitions and Guidelines," vol. I, August 15, 2003.
- [59] Naval Research Lab Stennis Space Center MS Mapping Sciences Section, M. C. Lohrenz, M. E. Trenchard, S. A. V. Myrick, P. Zuyle and R. E. Perniciaro, "Digital map requirements study in support of advanced cockpit moving map displays," October 10, 1997.

- [60] C. Bailey. Department of defense usage of FalconView, 2004. Retrieved January 28, 2009, from <http://www.falconview.org/docs/FalconView%20Usage%20Throughout%20the%20Department%20Of%20Defense.pdf>.
- [61] Department of Defense, "Department of Defense Interface Standard–Aircraft Display Symbology (MIL-STD-1787C)," January 5, 2001.
- [62] Department of Defense, "Department of Defense Instruction 5000.02–Operation of the Defense Acquisition System," December 8, 2008.
- [63] D. Anttila, K. DeLong, M. Skaggs and S. White. (2003), "Cockpit and mission system modernization." *Aircraft Engineering and Aerospace Technology* 75(2), p. 143. Retrieved March 11, 2009, from <http://www.emeraldinsight.com/Insight/ViewContentServlet;jsessionid=58EE9338E5CB9B9741D9AB6690B8903C?contentType=Article&Filename=Published/EmeraldFullTextArticle/Articles/1270750204.html>.

THIS PAGE INTENTIONALLY LEFT BLANK

INITIAL DISTRIBUTION LIST

1. Defense Technical Information Center
Ft. Belvoir, Virginia
2. Dudley Knox Library
Naval Postgraduate School
Monterey, California