

COAST ARTILLERY JOURNAL



FIRST COAST ARTILLERY
(HARBOR DEFENSE)

August

1926

Report Documentation Page

*Form Approved
OMB No. 0704-0188*

Public reporting burden for the collection of information is estimated to average 1 hour per response, including the time for reviewing instructions, searching existing data sources, gathering and maintaining the data needed, and completing and reviewing the collection of information. Send comments regarding this burden estimate or any other aspect of this collection of information, including suggestions for reducing this burden, to Washington Headquarters Services, Directorate for Information Operations and Reports, 1215 Jefferson Davis Highway, Suite 1204, Arlington VA 22202-4302. Respondents should be aware that notwithstanding any other provision of law, no person shall be subject to a penalty for failing to comply with a collection of information if it does not display a currently valid OMB control number.

1. REPORT DATE AUG 1926	2. REPORT TYPE	3. DATES COVERED 00-00-1926 to 00-00-1926			
4. TITLE AND SUBTITLE The Coast Artillery Journal. Volume 65, Number 2, August 1926		5a. CONTRACT NUMBER			
		5b. GRANT NUMBER			
		5c. PROGRAM ELEMENT NUMBER			
6. AUTHOR(S)		5d. PROJECT NUMBER			
		5e. TASK NUMBER			
		5f. WORK UNIT NUMBER			
7. PERFORMING ORGANIZATION NAME(S) AND ADDRESS(ES) Coast Artillery Training Center, Coast Artillery Journal, Fort Monroe, VA, 23651		8. PERFORMING ORGANIZATION REPORT NUMBER			
9. SPONSORING/MONITORING AGENCY NAME(S) AND ADDRESS(ES)		10. SPONSOR/MONITOR'S ACRONYM(S)			
		11. SPONSOR/MONITOR'S REPORT NUMBER(S)			
12. DISTRIBUTION/AVAILABILITY STATEMENT Approved for public release; distribution unlimited					
13. SUPPLEMENTARY NOTES					
14. ABSTRACT					
15. SUBJECT TERMS					
16. SECURITY CLASSIFICATION OF:			17. LIMITATION OF ABSTRACT	18. NUMBER OF PAGES	19a. NAME OF RESPONSIBLE PERSON
a. REPORT unclassified	b. ABSTRACT unclassified	c. THIS PAGE unclassified	Same as Report (SAR)	130	

17th Annual Prize Essay Competition

PRIZES

First Prize \$125.00
Second Prize \$ 75.00

CONDITIONS

(a) Subject to be chosen by competitor, discussing some phase of policy, tactics, or technique involved in the efficient accomplishment of the mission of Coast Artillery.

(b) Competition will be open to all readers of the JOURNAL.

(c) Award will be made by a committee of award, consisting of three persons, to be nominated by the Editor. If no essay submitted seems to the committee worthy of a prize, none will be awarded. Honorable mention may be made of any essay submitted which seems to the committee worthy thereof, but to which a prize is not awarded.

(d) All essays entered in the competition will become the property of the COAST ARTILLERY JOURNAL. These will be published, if valuable and interesting to JOURNAL readers.

(e) Copy must be typewritten, with lines double spaced, on one side of the paper only, and must be submitted in triplicate. If illustrations are included, one of the three copies thereof must be in the form of drawings, tracings, or photographs (not blue-prints nor brown-prints).

(f) Copy must contain nothing to indicate its authorship, must be signed with a *nom de plume*, and must be accompanied by a sealed envelope containing this *nom de plume* and the name of the writer. This envelope will remain in the hands of the Editor of the JOURNAL and, after award has been made by the Committee, will be opened in the presence of the Executive Officer, Third Coast Artillery District.

(g) Copy must be received on, or before December 31, 1926. It must be addressed COAST ARTILLERY JOURNAL and the envelopes must bear the notation, "Essay Competition."

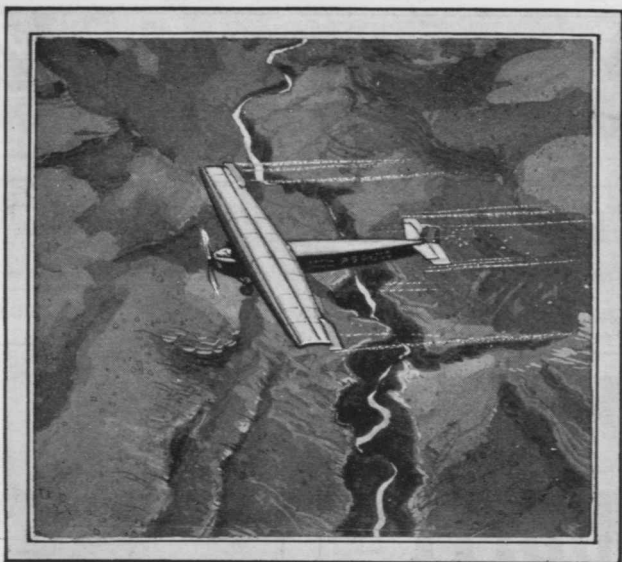

Reaching Through Space

Thousands of hands reach up to guide the aviator over unfamiliar territory, the hands of those who have gone out and painstakingly made surveys and sketches for Rand McNally & Company. Because these men have gone over the terrain foot by foot, the flyer flashes past overhead with all the assurance of one who travels on the ground.

All aviators know how trustworthy Rand McNally maps are. They use the very same maps that are sold everywhere for 35c. They know that trained workers are in the field every day for the sole purpose of keeping them up to the

minute. They have learned in actual flight that Rand McNally distances are absolutely correct, that no guess work enters into the making of the contours.

Rand McNally & Company are fully conscious of their responsibility in the close decisions that even the most experienced flyer is sometimes called upon to make. Backed by more than half a century's experience in scientific map making, Rand McNally & Company assure aviators and all others who use these maps that not one leaves their hands that is not perfect for the purpose for which it is intended.

RAND McNALLY & COMPANY *Map Headquarters*

Dept. H-183

536 S. Clark Street, Chicago 270 Madison Avenue, New York

Washington

San Francisco

Los Angeles

Newport News Furniture Co.
 INC.
 3100 - 3402 WASHINGTON AVENUE
 HAPPY HOME FURNISHERS

DIETRICH'S PLACE at Newport News

Will be always the Leading Restaurant of the Peninsula

DOWN SOUTH COOKERY

A PLACE BECOMING TO PERSONS OF CULTURE

The
EBBITT
HOTEL
 H STREET AT TENTH
 WASHINGTON · D · C

*The Newest Hotel in the
 Nation's Capital*

All rooms have private bath or shower;
 running ice water and electric fans;
 Dixie Room offers real Southern cooking; Convenient for motorists

ROOMS 12⁵⁰ PER DAY UPWARDS
 BOOKLET WITH MAP OF WASHINGTON SENT FREE

HOWARD EITCHISON - Supervisor
 & COMPLAINT Manager



There is a bottle of DYANSHINE for every color and kind of shoe. Be sure you get the proper one for your shoes.

The best is
 BARTON'S
 DYANSHINE

**BARTON'S
 DYANSHINE**
 TRADE MARK U.S. PAT. OFF.
 DOUBLE SERVICE SHOE POLISH

MANUFACTURED BY
**BARTON MANUFACTURING
 COMPANY**

WACO TEXAS

NEW YORK

CHICAGO

PARIS

Brentano's Inc.

Any Book in Print

BOOKSELLERS, ENGRAVERS AND STATIONERS

F and 12th Streets Telephone Main 861 Washington, D. C.

THE PURITAN CONFECTIONERY

31 EAST QUEEN STREET
HAMPTON, VIRGINIA

PURE HOME MADE CANDIES AND ICE CREAM

*Home Made After-Dinner Mints, Salted Almonds, and Whipping
Cream a Specialty*

PHONE 856

I. LIPMAN & COMPANY

33rd St. and Virginia Ave.
NEWPORT NEWS, VA.

ARMY AND NAVY SURPLUS EQUIPMENT

PLUMBING AND MARINE HARDWARE AT REDUCED PRICES



Clean Hits Come from Clean Guns

And a gun is clean only when the potassium chloride (salt) residue of the primer is **completely** dissolved. Chloroil is the only solvent which will dissolve the primer salts and prevent after-corrosion—removes metal fouling. Used by all International Teams representing the United States for the last three years.

The Stazon Kit

Chloroil comes packaged in the attractive Stazon Kit together with Stazon Gun Oil, Stazon Gun Grease and Stazon-Rustoff. Everything necessary for the complete care and preservation of your firearms.

If not carried by the Post Exchange send \$1.00 for the Kit or \$.35 for Chloroil direct to



Gun Cleaning Headquarters
Conversion Products Corporation
622 S. Delaware Ave.,
PHILADELPHIA, PA.

BROADWAY DEPARTMENT STORE

NEWPORT NEWS, VA.
3007-09 Washington Ave.

DRY GOODS, NOTIONS, MEN'S FURNISHINGS

HOUSE FURNISHINGS

EXCLUSIVE READY-TO-WEAR

AGENTS FOR McCALL'S PATTERNS

PHONE 736

BLOXOM BROTHERS

WHOLESALE FRUITS AND PRODUCE

23 MELLE STREET

PHOEBUS, VIRGINIA

WHEN WRITING ADVERTISERS PLEASE MENTION THE COAST ARTILLERY JOURNAL



**DEER
PARK HOTEL**
DEER PARK MARYLAND
"HIGH UP IN THE ALLEGHENY MOUNTAINS
Where Spring Spends the Summer"
elevation of 2600 ft. insures a cool invigorating climate
18 Hole Golf course, Tennis, Saddle Horses,
Swimming pools, Music and Dancing;
Excellent table - Very moderate prices.
200 Rooms - 100 Baths - 10 Cottages.
Booklet sent upon request -
H. P. DUNCAN
Manager

Depository of the U. S. Government

**THE FIRST NATIONAL BANK
OF HAMPTON, VIRGINIA**

Capital	\$ 50,000.00
Surplus and Profits (earned) over	100,000.00
Total Resources over	1,800,000.00

**CONSERVATIVE
STRONG
ACCOMMODATING**

H. H. KIMBERLY, *President*
R. C. WINNE, *Cashier*

P. J. DRUMMOND, *Assistant Cashier*
J. C. ROBINSON, *Vice-President*

4% INTEREST ON SAVINGS ACCOUNTS

THE COAST ARTILLERY JOURNAL

Published as the Journal U. S. Artillery from 1892 to 1922

MAJOR ROBERT ARTHUR, C. A. C. *Editor and Manager*

CAPTAIN D. L. DUTTON, C. A. C. *Assistant Editor*

Volume 65

AUGUST, 1926

Number 2

CONTENTS

FACULTY AND STAFF, COAST ARTILLEY SCHOOL, 1925-26	<i>Frontispiece</i>
THE MISSION AND WORK OF THE NAVAL WAR COLLEGE	111
<i>By ADMIRAL W. V. PRATT</i>	
SOUND LOCATORS: THEIR FUNCTIONS AND LIMITATIONS	123
<i>By LIEUT. H. B. ELY</i>	
AIRPLANE OBSERVING FOR ANTI-AIRCRAFT FIRE	132
<i>By LIEUT. R. W. RUSSELL</i>	
ATHLETIC ORGANIZATION AND MANAGEMENT	139
A PLEA FOR A STRONG ANTI-AIRCRAFT DEFENSE	156
<i>By LIEUT. COL. D. F. F. HOYSTEAD</i>	
CHARACTERISTICS OF 8-INCH GUNS AND 12-INCH MORTARS, RAILWAY MOUNTS	<i>By CAPT. G. W. RICKER</i> 161
EDITORIALS	169
<i>The Army a Training School—Artillerymen—The Personal Budget— Warlike America—Champions of Defense—What Unpreparedness Cost the World—Officers Forced Out—"Compulsion" in Colleges—For "War Purposes"—Moros on the Warpath.</i>	
PROFESSIONAL NOTES	179
<i>Correction of Data for Errors of Averages Obtained from Small Samples —Noncommissioned Officer Personnel—"You're in the Army Now"— An Address—Foreign Periodicals—470 Holes in One Target—A Lan- guage Detail in Japan.</i>	
MILITARY NOTES	199
<i>Foreign Legion in the Russian Army—Marriage Regulations for Italian Officers—Cost per Soldier of Leading Nations—Fiftieth Anniversary of the Founding of the Ecole de Guerre—Spring Meet of the Japanese Riding Association.</i>	
COAST ARTILLERY BOARD NOTES	203
BOOK REVIEWS	207

Authors alone are responsible for statements in contributed articles

Published monthly under the supervision of the Commandant, Coast Artillery School, by direction of the Chief of Coast Artillery, for the information of the Coast Artillery personnel of the Regular Army, National Guard, and Organized Reserves.

Terms: United States, \$3.00 a year; single copies 50 cents. Canada, \$3.25 a year; single copies, 55 cents. Foreign, \$3.50 a year; single copies, 60 cents.

Entered as second class matter at the Post Office at Fortress Monroe, Va. Acceptance for mailing at special rate of postage provided for in Section 1103, Act of October 3, 1917, authorized 3, 1920. Copyright, 1926, by the COAST ARTILLERY JOURNAL.

Address: THE COAST ARTILLERY JOURNAL, Fort Monroe, Va.

Printed by HOUSTON PRINTING AND PUBLISHING HOUSE, Hampton, Va.

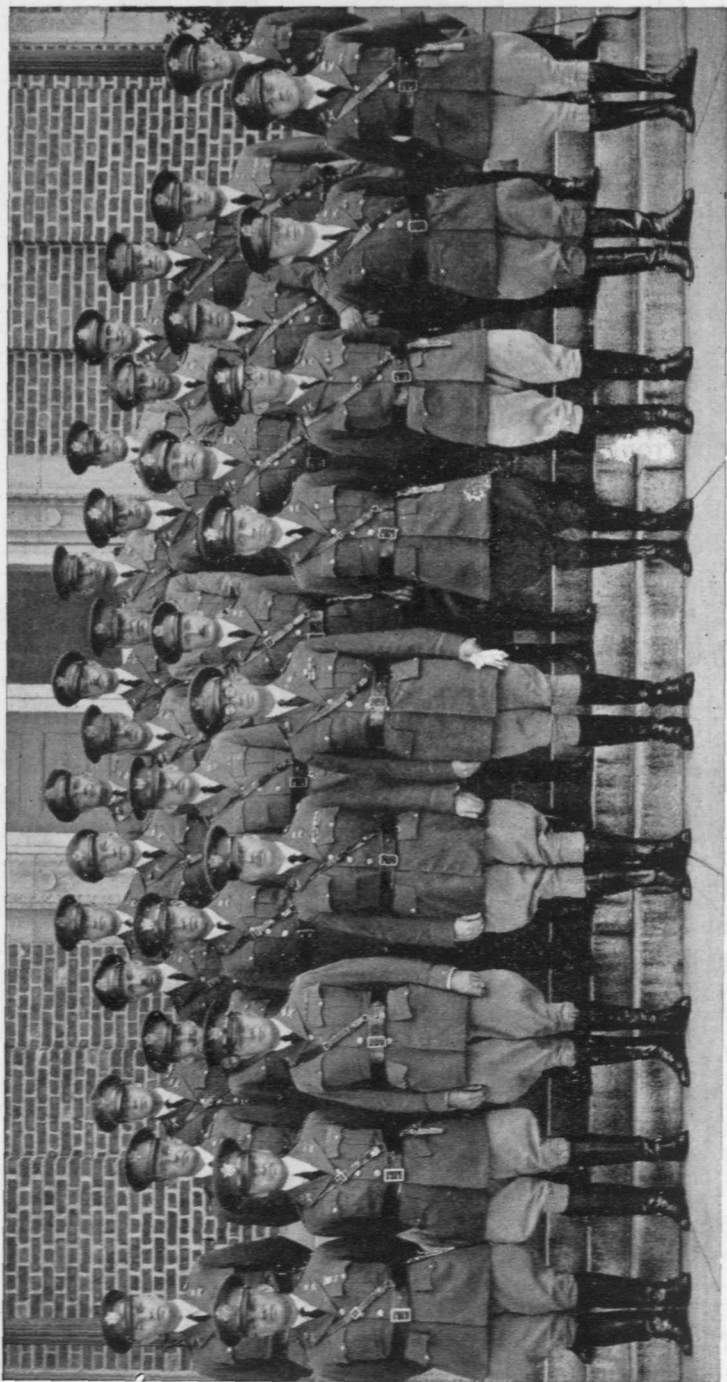

FACULTY AND STAFF, COAST ARTILLERY SCHOOL, 1925-26

First Row: Capt. G. B. Welch, Maj. F. M. Green, Maj. H. K. Loughry, Lt. Col. W. H. Wilson, Brig. Gen. R. E. Callan, Maj. F. Q. C. Gardner, Maj. R. Arthur, Maj. E. J. Colten, Maj. R. V. Cramm.
Second Row: 1st Lt. V. Schmidt, Maj. W. W. Hicks, Maj. A. J. French, Maj. G. R. Meyer, Maj. F. P. Hardaway, Maj. R. E. Guthrie, Maj. R. H. Smith, Maj. F. E. Gross, Maj. C. M. Thiele, Maj. J. D. Kelly.
Third Row: Capt. K. McCarty, Capt. P. H. French, Capt. R. B. Bottom, Capt. R. H. Holmes, Capt. C. H. Ainsworth, Capt. I. B. Hill, Capt. O. J. Bond, Capt. S. D. McCrosky.
Fourth Row: Capt. K. S. Purdie, Capt. R. W. Argo, Capt. D. L. Dutton, Capt. C. S. Harris, Capt. G. W. Whybark, Capt. H. H. Blackwell.

THE COAST ARTILLERY JOURNAL

Volume 65

AUGUST, 1926

Number 2

Mission and Work of the Naval War College

By ADMIRAL W. V. PRATT
United States Navy

THE ORIGINAL CONCEPTION

IN order to give a clear conception of the work of the Naval War College, of its aims, its purposes, its present accomplishments, and its hopes for the future, it will be necessary to make a cursory survey of the situation from the date of the original conception of the institution. In making this review the liberty has been taken of using the data furnished in the *Life and Letters of Rear Admiral Stephen B. Luce, U. S. N.*, written by Rear Admiral Albert Gleaves, U. S. Navy, and frequently of quoting directly from that book.

In writing to the Secretary of the Navy from the U. S. S. *Hartford* in August of 1877, Rear Admiral, then Captain, Luce advocated the establishment of a school wherein our junior officers would be carried through a post-graduate course consisting of the higher branches of their profession. The leading feature of the post-graduate course was to be the carrying of the young officers through a course of instruction in the art of war. Admiral Luce further suggested, as a preliminary step, the sending of a select few of our officers to attend a course of instruction at the Artillery School at Fort Monroe. While the purpose of this detail was to prepare naval officers to become instructors at the naval school, nevertheless it should be noted that the bringing together of officers of the two services bent upon learning the fundamentals of their professions would assuredly result in a certain degree of cooperation between them, and would, in effect, pave the way for the joint consideration of military problems, a matter which today is accepted as essential. It is well to note here that the mission of the new naval school was outlined tersely by Admiral Luce in the words "Instruction in the art of war."

In October of 1877 Brigadier General Emory Upton, in writing to Admiral Luce, approved of the latter's project to establish the naval

school as a worthy one and, as he said, "Someone must start the scheme, and I sincerely hope that, as you have done so, you may be able to inaugurate the course and witness its triumph."

In 1883, lecturing before the Naval Institute, Commodore Luce suggested "the establishment of a post-graduate course for the study of the science of war, the object of which would be to prepare officers for the great business of their lives, namely, the practical operation of war." In addition to the study of war, he recommended a higher course in ordnance, a course in international law, the higher mathematics, languages, astronomy, and hydrography. While his efforts commanded respectful attention, they did not excite much enthusiasm or even interest in the subject.

As a result of his efforts, in 1884 Secretary Chandler appointed a Board, of which Luce was President, to report and consider the whole subject of a post-graduate course or school of application to be established by the Department for officers of the Navy. In June of 1884, the Board submitted an exhaustive report. The decisions of this Board were so important and to this day outline so clearly the goal toward which the Naval War College should strive that the liberty is taken of quoting in full certain of its opinions:

Campaigns that have depended for success upon the cooperation of a fleet; campaigns that have been frustrated through the interposition of a fleet; the transfer, by water, of a numerous army to distant points and their landing on enemy's coast under the guns of a fleet; the various results of engagements between ships and shore batteries; naval expeditions which have ended in disaster that could have been foretold through an intelligent study of the problem beforehand; and the great naval battles of history, even from the earliest times, which illustrate and enforce many of the most important and immutable principles of war, should be carefully examined and rendered familiar to the naval student. For it is upon this professional skill in the large operation of combining and utilizing to the best advantage, the floating force of the country, as well as in the more restricted one of an isolated command, that our people must rely for the protection of their interests and the guarding of their extensive coasts and coasting trade from the depredations of an enemy. * * *

Naval officers are often called upon on foreign stations to exercise diplomatic functions, and are, not infrequently, required to settle or act upon questions involving nice points of international law. They should, therefore, be carefully prepared for this responsibility by an intimate knowledge of the enlightened neutrality policy which this country has had the honor of introducing and maintaining from the foundation, and of the principles of equity that have ever characterized, as well as of the instruments which control the intercourse of the United States with foreign powers.

It is well to study these statements for they really denote the mission of the Naval War College. From time to time, other and more terse

missions have been assigned but nowhere will there be found a more comprehensive view of what the War College should mean to the Navy and to the Country than in the two paragraphs above. The methods we adopt to perfect ourselves in the carrying out of the above missions may change, but the fundamentals enunciated stand proved through time.

As a result of this report, an order was issued by the Navy Department in 1884 establishing a college for an advanced course of professional study for naval officers, to be known as the Naval War College. In 1885, the Naval War College was founded at Newport, Rhode Island, and Admiral Luce was made the first president.

Even though the College was established, it passed through many vicissitudes before its importance was recognized. The first class consisted of eight student officers assembled for a course of one month. In 1886, 1887, and 1888, during the presidency of Captain Mahan, there were classes of about twenty officers each year for courses of from two and one-half to three months. In 1889, an order was issued transferring the War College from Coaster's Island to the Naval Torpedo Station on Goat Island and a consolidation of the two efforts—one, production of material; the other, study—was attempted. This was disastrous, and had it been persisted in, the future of the War College, in all probability, would have been doomed. In 1890 and 1891 there were no War College courses. In 1892, with Mahan again as president, the class was renewed but in 1893 no class was ordered. The War College had many enemies at the Department who conscientiously believed that it should not exist as a separate institution. However, the present War College Building was completed in 1892 and during the period 1894-1896 the College seemed to have confirmed its value in importance and was apparently firmly established. Even then there was a body of thought which believed it would be wiser to transfer the College to Annapolis and make it an adjunct to the course there. Fortunately this opinion did not prevail. In 1899 there was no class assembled at the War College. From time to time after 1900 the idea cropped up that it would be wise to transfer the Naval War College to Washington. The genesis of this idea probably lay in the fact that by being at Washington the College would serve a dual purpose; that is, it would be a school for study and might also be part of the organization of the Navy Department, particularly in matters pertaining to advice and planning. In this proposal, the original purpose of the College, as outlined by the Board which recommended its establishment, was lost sight of. The organization of the Department at this time was in itself so incomplete (the Office of Operations not having then been established) that a need was felt to utilize the work of the War College in an administrative way. The immense advantage, however, of

having the College in a place where through personal contact it could effect cooperation with the Fleet was entirely lost sight of by those who advocated the transfer.

During the first twenty-five years of the College's existence, the names of three men stand out above all others. They have given it an indelible stamp. They are Admiral Luce, who gave the College life and established its mission; Captain Mahan, whose works on Sea Power brought it fame; and Captain McCarthy Little, whose untiring devotion kept the spirit of the College alive during its most trying days.

THE COLLEGE JUST PREVIOUS TO THE WORLD WAR

Even as late as fifteen years ago, just prior to the World War, while the College was recognized as a valuable asset to the Naval establishment, its full importance was not appreciated. The College was tolerated, but it was not looked upon as being one of the most essential features of the Navy.

About this time, during the administrations of Admiral R. P. Rodgers, Captain W. L. Rodgers, and Admiral Austin Knight, a change in the method of instruction was inaugurated. The scope of the problem work was increased and the method of instruction was definitely based upon a practical and competitive system. This resulted from a study of the German method of the solution of a problem, which consists of a derivation of the mission, an estimate of the situation following an ordered course of reasoning, the arrival at a concrete decision, and the translation of that decision into action through a concise order.

From this time the internal work of the College was increasingly progressive, but the external relationships existing between the College and the rest of the naval service were by no means so satisfactory. Even in its internal work the College had not reached the point where it was able to take up in detailed study the partnership existing between the two military establishments, or the coordination demanded between the military establishments and the other branches of the Government, or the relationship of the combined executive departments to the national resources of the entire country. In fact, it took the World War to clarify our thoughts and extend our vision in this direction.

During the period now spoken of, while much advance was made in the internal development of the College, nevertheless the mission of the College as outlined in the Board's report was sometimes lost sight of. Perhaps it might better be said the time had not yet arrived where the College was in a position to undertake the work which at times the Department placed upon it. To illustrate: The course at the Naval War College during this period partook of the following characteristics. There was given opportunity for study; the solution of

naval problems under the applicatory and competitive system went on; but, in addition, from time to time the Department, due to its faulty organization or, rather, lack of organization in that most essential feature, a fully developed office of operations, occasionally threw upon the College work which properly belongs to a War Plans Division. Had the College been assigned the task of testing plans already made, this would have been another matter and a legitimate function, but, there being no War Plans Division, the College frequently was forced to make the plans and to test them in addition to its work of education, and this was neither correct in principle nor in practice. Further, the great importance of conducting studies of joint operations through the problem-solving method in connection with the Army was not fully realized. This is somewhat strange, for if the original report will be referred to, it must be noted there that the necessity for a study of joint operations is strongly stressed. Howbeit, the work of the College had produced such good results that at the opening of the World War there was a small body of Naval men who were more competent to face the complex situations confronting them than if the College had never existed. In fact, no less a person than the Chief of Naval Operations during the World War, Admiral Benson, although not a graduate of the College, has often expressed his appreciation of the work performed by graduates and he himself was careful, in so far as he was able to do it, to place in positions of major responsibility those officers who had received the benefits of a War College training.

During the first two and a half years of the World War the College continued its courses and had the opportunity for studying the conduct of the war from the point of view of a neutral. This period proved of much value to the College in enabling it to formulate more definitely its ideas of war and particularly in extending its vision. Although this period was one of great importance to the War College, it was of even more value to the Navy Department.

In May of 1915, Admiral Benson was selected to be Chief of Naval Operations and with his appointment the Office of Operations, corresponding to that of the General Staff of the Army, came into existence on a practical basis. Formerly this work had been done through an Aide for Operations but the labor falling upon the shoulders of one man was so great that he could, for all practical purposes, serve only as an adviser. The details which logically must fall to the lot of an Office of Operations were so numerous that one Aide could do little more than to act in an advisory capacity. An Advisory Board was already in existence in the General Board. This defect in the Departmental system was bound, in the course of time, to lead not only to a clash of opinion between the advisory functions of the Navy, but also

failed to demark the lines of cleavage which should exist between the administrative functions, the advisory functions, the planning functions, and the study of the problems of war. There resulted a confusion of ideas as to the proper spheres of action of the Office of Operations, the General Board, and the War College.

With the establishment of the Office of Operations on a correct, though limited footing, the proper functions of the three major shore organizations of the Naval Establishment became more clearly outlined. The first result was immediately felt in the War College. The character and scope of its work at once took on more definite shape. The same can not be said of the relations which existed at this time between the General Board and the Office of Operations. A true appreciation of the partnership which should unite these two bodies did not come until some time later. In fact, it may be called a development of the War.

Upon our entry into the War, the College closed and did not reopen until fully six months after the armistice was signed. In the meantime, however, an understanding of the purpose of the College had become more definitely fixed in the minds of students of military and world affairs. During the time of our participation in the war, as was natural, the Office of Operations received a great impetus and was able to develop along logical and proper lines. The General Board, on the other hand, instead of taking unto itself administrative functions, reverted to its original conception, that of a purely advisory body. These results were to have an enduring influence upon the War College when it was again reestablished at the close of the War. By this time the place and function of the executive and administrative factors, the plan making factor, and the advisory factor were better understood and had been definitely fixed.

THE PERIOD SINCE THE WAR

After the war, the College was reopened under the able administration of Admiral Sims, who had played a most distinguished rôle during the struggle. The College began its new life with an increased vigor. The lessons of the war were fresh in the minds of every one, the value of the College had been demonstrated, and there existed now a definite desire on the part of most officers to take advantage of the course of study offered to them. This desire was increased by Departmental orders which indicated that the higher commands, so far as it might be practicable, should go only to those who had received the benefits of War College training. Instead of a paltry few officers taking the course, as had been the case formerly, the classes now increased in size and the staff of the College was augmented correspondingly. During his entire administration Secretary Daniels was an ardent advocate of the War College.

About two or three years ago, under the impetus of Assistant Secretary Roosevelt, the field of the College work was further expanded. Previous to this time there had been only one class. Following the lead indicated by Colonel Roosevelt, the scope of the work of the College was enlarged to include two classes, a senior and a junior class, and the correspondence course initiated by Secretary Daniels in 1914 and again reestablished in 1919 (to be taken by any officer in the Navy) was continued. Arrangement was made also for an additional and higher course to be established at the War College when the time should be ripe to accomplish this. The latter step has not yet been taken.

Since the increase in the scope of work, pursuant to the movement inaugurated by Secretary Roosevelt and up to 1926, the internal assignments of the College have been as follows:

- (a) A correspondence course dealing in the elementary study of tactics and of international law;
- (b) A junior course, established to fit younger officers for staff duties, dealing in problems of tactics and minor strategy;
- (c) A senior class undertaking more extensive tactical and strategical problems.

The study of international law, which has been carried on since the time of the first founding of the College, was continued, but the output was not as great as it had been in earlier periods of the College history. Lectures on international relations were frequently given, but a division for the study of international affairs had never been created and there was not the sound, official, and correct background upon which to base our more technical naval studies.

Two other fields of work, essential for an understanding of our country's military needs, were undeveloped. The first field of endeavor lay in a study of the proper relationship which must exist between the naval establishment and national resources, and the second field of effort lay in the matter of joint operations conducted by the two military branches of the Government. It is true that an appreciation of the need for study and problem work in these two fields has been recognized, for in the last few years several joint problems have been played by the Army and Naval War Colleges working together, but a deep sense of the necessity for greater study and problem work along the line of joint operations did not exist at the Naval War College. This was natural under the system of organization existing at the War College up to 1926. Too much thought was spent upon the separate departments of tactics and strategy, and too little attention was paid to the fact that strategy and tactics are not separate fields of activity but

both merge together under the head of operations, and that operations, even purely naval, cannot hope to succeed unless careful attention is paid to material, personnel, and the thousand detailed difficulties attendant upon war. Until a proper appreciation exists between the purely naval operation and its attendant activities, there is little hope that a full perception will be had of the immense scope of activities attendant upon a broad plan of campaign involving both military services.

To illustrate more clearly this point, there is quoted from a statement prepared by the Navy Department relative to the mission of the Naval War College and the policy of the Department relative to the assignment of its graduates to important commands, the following. This statement was prepared for Congress and was dated December 4, 1925. In it the mission of the War College is stated as follows:

The mission of the War College is to furnish a medium whereby naval officers may in peace time study the conduct of naval warfare and the art of command in relation thereto. The college puts the student through a selective course of reading, lectures, and instruction and by practical naval war games teaches him to apply his acquired knowledge on the game board in solving strategical and tactical problems; starting in an elementary way and working up to major fleet operation. A correspondence course, consisting of selected material, lectures, and problems for solution, serves as a medium of preparing officers in general service for the work of the college or of enabling an officer, who because of his duty has not been to, or is unable to attend, the college, to keep up with the development in strategy and tactics. Any officer may be placed on the War College lecture distribution list at his request and keep abreast of the special lectures or even of the tactical studies or critiques of the tactical games.

In carrying on this work the College naturally has become a research and experimental laboratory for naval strategical and tactical practice.

This may be an adequate statement to furnish Congress, but the president of the War College insists that this is not a complete statement of the mission of the War College, nor is it as broad in its scope as the enunciation of principles laid down by the original board in 1884 at the time when the College was first to be founded. As has been pointed out in preceding statements, the limited view outlined in this last statement of mission by the Bureau of Navigation would preclude the College from undertaking studies along the broad lines indicated before. The field of international relationships is not touched upon; hints of the studies necessary to fit higher officers to cope with many of the international problems confronting Naval men in times of peace are not there; that most important work, the conduct of joint operations in a grand campaign of war, is not even suggested; the testing of war plans prepared by the Department is not spoken of; the cooperation which must exist between the War College and the Fleet

in the staging and solution of the latter's practical sea problems is not mentioned. Unless all of these features are incorporated into the work of the Naval War College, eventually the College will have failed of its full purpose. It is true that the College exists for the purpose of studying the art of war. Admiral Luce used these words in his first letter, but he said war and not naval war only. This is its major purpose, but it is likewise true that between wars there are long periods of peace. The mission of the Navy is to know not only how to conduct efficient war in time of war, but, in time of peace, the Navy must know how to keep the peace! These problems constantly confront Naval men. As outlined by the original Board, a knowledge of International Law and of international relations is one of the prime duties of a naval officer and nowhere can he find better opportunity to equip himself for these duties than at the War College.

THE PRESENT ATTEMPT TO REMEDY THE ABOVE CONDITIONS

An attempt is now being made to remedy the above deficiencies. The proper evolution of the College demands an increase in the scope of the work hitherto assigned and a different arrangement. The College should proceed to adjust itself to meet the increased demands. As a first step, a reorganization of the Naval War College has been effected. This was made after an exhaustive study of the principles of command and administration, with the result that the Naval War College, as it exists today, is organized on lines similar to that of the General Staff of the Army and the Office of Naval Operations of the Navy. This does not mean that the War College attempts executive, administrative, or advisory work. It means, however, that it will attempt to formulate its problems and conduct its studies with a recognition of the fact that certain deciding factors enter into the composition of every war problem. The six principal elements to be considered are as follows:

- (a) Personnel, material, supply;
- (b) Information;
- (c) Operation;
- (d) Policy;
- (e) Inspection;
- (f) Finance.

Naturally, in the College work where the time is devoted to study, such matters as inspection and finance, except as finance may come under the head of logistics, play a minor rôle, but matters of personnel, material, and supply, lumped under the head of logistics, and such factors as information, operation, and policy must be given great weight. There-

fore, in drawing up the organization plan for the War College, it was found practicable to make a department called Division D which is the Policy and Command Department. This takes in the correspondence course, the contemplated advanced course, the lecture course, and the study of policy, international law, and foreign relations. Division A, which is called the Logistics Department, deals with questions of material, personnel, supply, transport, and priorities. Division C, the Division of Operations, deals with war plans, estimates of the situation, orders, and problems pertaining to military and naval operations; and Division B is the information division. It is hoped that through this reorganization more comprehensive studies may be made along lines that would be of practical benefit to the Department in case of war, without in any way detracting from the value to the student of the lessons learned through his study of these problems. To sum up concisely, the student does not act nor does he advise, but he studies and, in studying, the scope of his work covers not only the problems of naval strategy and tactics but includes the subjects outlined in the reorganization.

Perhaps it will now be seen how much more readily the Naval War College will be able to undertake joint war problems under the present reorganization than under the old. We now think, or attempt to think, in matters pertaining to the Art of War along lines similar to the Army's way of thinking, and this would seem to be wise for, after all, there is no difference in principle between naval and military strategy and tactics though there are essential differences in movement and time. In matters of logistics it is a question of detail and not of principle that is involved. Only one feature is stressed to a greater degree than the Army would stress it and this is the matter of international relations. The reason for this is self-evident. The Navy is the external buffer between our Federal State and other sovereign States. It works in this capacity both in peace and in war. The Army is the internal protector of the country and, broadly speaking, it only comes into contact with foreign States after war has been declared. Through this reorganization an attempt will be made in the future to give more emphasis to the solution of problems involving joint operations and to insure complete liaison with the Army War College.

In time, it is hoped to extend the Naval War College curriculum by an advanced course devoted to the study and the solution of broader military problems and to the study of international relations, carried to a more intensive degree than has been undertaken heretofore. To receive full value, however, the Department must at an early date perceive the necessity of inaugurating the advanced course and provide the means for carrying on.

LECTURES AND INTERNATIONAL LAW IN THE NAVAL
WAR COLLEGE COURSE

First, let us take the question of International Law. This is a most important course for naval men. Fortunately, in the past we have had the services of one of the best international lawyers in the country, George Grafton Wilson, of Harvard. As a result, the Naval War College yearly has edited a blue book which comprises the international law problems given to the class for solution that year. This book has been in demand the world over. Without thorough grounding in this branch of the naval profession no officer is competent to face the complex problems which constantly confront him during the course of war, particularly in his contacts with neutrals. In times of peace he is frequently the only Government representative on the spot and must act wisely and quickly. During the last year an officer has been permanently assigned to the College to handle International Law in conjunction with Dr. Wilson.

In the matter of international relations and of economics, it has been realized that while the students glean most valuable ideas and facts from attendance upon the lecture course, nevertheless the opinions of the various lecturers are sometimes personal opinions and they may not have the official backing of the State Department. Therefore, to base our technical problems upon policies enunciated by these men, no matter how learned, is not to furnish the best background upon which to rest our naval studies. The opinions of competent private individuals, although extremely valuable, lack the weight of official backing and must be carefully sifted at times to separate the fact from the personal opinion. Therefore, an attempt has been made during this year to enter into a closer liaison with the State Department, and progress is being made along these lines.

THE COURSE FOR THE COMING YEAR

During the coming year the course at the Naval War College will be so directed that more stress is laid upon the solution of joint problems if this suits the needs of the Army War College. This is necessary in order that Naval and Army commanders will feel thoroughly assured of the complete cooperation which must exist in order effectively to conduct a joint campaign. As a matter of fact, at the Naval War College we have concerned ourselves too much with playing naval games within our own padded cell and devoted too little thought to other problems of war. In the past there has been excuse for this. The officers come for a one year's course without previous training. There is no advanced course founded. As a result it is difficult to get beyond the elementary stages of study. But there is no excuse for the

Department or the College to fail to recognize the necessity for advanced work.

FINALLY

The above discussion leads to some slight comment on the Joint Board. This organization is bound to be of supreme importance in any war in which America is involved and yet how can we produce men competent to take their places on such a Board and play a proper rôle there unless at the two colleges we recognize the extreme importance of joint operations and adequately prepare our students to cope with the problems which would confront this Board in time of war.

If we were, however, to look at our naval problems from this angle alone there would be logical reason to assume that the War College could do its best work in Washington. However, this is not so. We believe that it is for the best interests of the Naval Service to keep it at Newport. There we are enabled to establish physical contact with our own fleet and to help in the solution of our own problems to an extent which we could not do if the College were at Washington. We would suffer greatly internally if it were moved from its present location. Moreover, there are other reasons which render this move impracticable. Nevertheless, nothing could stand in the way of that complete cooperation with the Army War College which is essential if the two services are to put forth their best united effort towards undertaking the study of those problems sure to confront America in case of war. Therefore, it behooves us not to think apart, not to work in separate rooms, but jointly to do our best to work together harmoniously and in thorough cooperation as loyal servants of our Government and to this end every effort will be made by the Naval War College to enter into complete cooperation with the Army War College at Washington. If we both keep this idea in view, as the years run by, the two institutions will be drawn closer together and march down the corridors of time step by step ready when the country calls to give it the best results of years of thoughtful labor.

Sound Locaters: Their Functions and Limitations

By LIEUTENANT HIRAM B. ELY
Ordnance Department

DURING the late war in Europe the sound locator, like so many other instruments of war, came into being for the first time. The old story of the appearance of a new offensive weapon calling for a new means of defense was repeated. The sound locator is a part of the defense used against the airplane, a new and powerful weapon which sprang into existence as a war machine during the last great war and has steadily gained in importance in this capacity. A large part of the mission of the airplane is accomplished at night under the cover of darkness when visual means for detection cease to function. It is then that we turn to our second great sense of perception which is only sharpened by darkness and the stillness of night, and seek out the thrum of airplane motors and the whir of their propellers by the aid of acoustics. Just as we use telescopes or field glasses to aid the vision in seeing more clearly or more distantly and to determine directions, so we use sound locaters to amplify sounds so that we can hear further and to give us the directions of these sounds.

The first devices used by the French were of the paraboloid type—huge bowl-shaped instruments, six to twelve feet or more in diameter and capable of being swung in azimuth and elevation so as to point to a source of sound. Theoretically, a paraboloid will focus incoming sound waves just as a searchlight mirror focusses light, and when a maximum of intensity is obtained the device points in the direction from whence the sound comes. Because of the fact that sound waves are much longer than light waves, the focus is not sharp unless the paraboloid is made too large to be handled conveniently. The next device developed by the French was the telesitemeter which used as sound receivers clusters of short conical horns arranged in honey-comb fashion, all the ends being connected by tubes into one large tube. Two of these clusters, or nests, were on one axis and two on another at right angles; the tubes from each pair were led to a stethoscope through which the operator listened. In this instrument location by maximum intensity was discarded and the binaural phase effect was used for the location of sounds.

The telesitemeter designed by Perrin was adopted as standard by the French and was used very extensively toward the end of the war. Many acoustic charts of airplane night raids were made by means of this instrument. Stations were set up around an important center like Paris at intervals sufficiently close that an airplane could be covered constantly. The instruments were not highly efficient as compared to visual devices but the visual devices went out with daylight and anything was better than nothing. Anything that could give a more exact direction than the unaided ear was worth having.

The English used various sizes of short conical trumpets, up to about three feet in length, in sets of four, two for azimuths and two for elevation, and mounted in such a way that all four could be turned freely in any direction. These horns would give direction but were no better than the ear alone and probably not as good for obtaining distance.

The principal acoustic development work in our army during the war was done by Stewart with long horns. These were conical horns fifteen or eighteen feet in length and set up in pairs of fours on axes capable of giving rotation in azimuth and elevation. The binaural principle was again used, the horns being connected by pairs to the ears of operators. They turned the device so as to keep the sound centered, that is, directly ahead, whence the instrument would be pointing toward the origin of the sound. These horns were very efficient acoustically but the set-up was too cumbersome to be moved from place to place, and was never developed into a mobile unit.

After the war very little was done on sound locator development until 1924. Commencing then, a study was made of existing devices and of new principles with a view to developing an efficient sound locator. In the fall of 1924 a semblance of a sound locator came into existence in the form of a two-horned device, rather crude but a step in the right direction. The horns were of a new design and held great promise. They were the first exponential horns used for receivers of sound and this type of horn has since demonstrated itself to be vastly superior to any other type either for receiving or for radiating sound.

The following winter proved to be an important one for antiaircraft artillery because of the fiery denunciation of its capabilities by the advocates of a unified air service and the demand that it prove itself in order to remain in existence. Preliminary tests were held at Fort Monroe and plans for an extensive series of tests for the summer were laid. The preparations included the requirement to equip each of the antiaircraft regiments with a new and efficient type of sound locator. Development had not reached a point where a proved device was ready, but the opportunity was offered to put before the service certain new principles which savored of success. While thorough laboratory tests

should precede submission of untried principles to the users in the field, still practical use in the field is a valuable test by itself and the results are highly useful to those charged with development work in determining how well a device with certain characteristics will function. The



FIG. 1. EXPONENTIAL SOUND LOCATOR, T-2

demand was presented and those carrying on the sound locator development could "put out" or fail without even an effort. The result was that a new type of sound locator, the Exponential Sound Locator, T-1, was built in sufficient quantity to provide three units for each of the six regular antiaircraft regiments.

The sound locator depends for operation upon the binaural principle or the binaural sense. Human beings are provided with two ears; when a sound wave approaches the head, it will impinge upon one ear a fraction of a second sooner than upon the other unless the listener is looking in the direction of emission. The resulting sensations are analyzed in the brain by point of time and by instinct the sound source is known to be at a certain angle to the right or left of straight ahead. If he desire, the listener turns his head that angular amount and appears to be looking directly at the source of sound. In other words, the sound will be centered in his head.

This ability of the ears and brain to determine direction acoustically is called the "binaural sense"; the effect of the sound wave on the ears is called the "binaural phase effect." The sound locator merely extends the ears through two large horns at the ends of a base line longer than that of the two ears so that the phase difference for a given angle will be greater, thus sharpening the binaural effect. In addition, an amplification is obtained by properly designed horns and the incoming sound wave can be heard several times louder than with the naked ear. Two horns are used for azimuth and two in the plane at right angles to that of the first two for elevation determination. The small ends of the horns extend through flexible tubes to earpieces contained in a leather helmet worn by the operator. The horns are mounted on a single pedestal and are manipulated in azimuth and elevation by hand wheels. They are capable of swinging through the full circle in azimuth and to minus ten degrees on both sides of the zenith.

The principal function of the sound locator at present is as an auxiliary to the searchlight in direction-finding of airplanes. It has a very broad field while that of the searchlight is limited to several degrees. The range is also greater than that of the searchlight so that an airplane can be located and the beam of the light opened on the plane as soon as it comes within range without the loss of time used in searching with its consequent position disclosure. An added function of the sound locator is that of an observation instrument for warning purposes in the protection of large defended areas such as cities. Sound locator stations invisible at night can be placed at intervals about such areas and will give very accurate information as to the approach of hostile aircraft.

It is the accepted opinion that for mobile batteries plotting systems for sound locators are impractical and the single station method is to be used. The sound locator is set up several hundred feet from a pilot searchlight and connected thereto with some means of data transmission (at present telephonic). At the sound locator a predictor is used which corrects for sound lag, and for wind if meteorological data is available,

and predicts ahead the position which the target will occupy at the end of the time interval. This predicted data is transmitted to the searchlight where it is set off and when the searchlight commander gives the command "In Action," the beam should fall on the airplane unless the latter has changed its course.

The complete system then comprises the sound locator, the searchlight, the predictor, the data transmission means, the listeners, and the searchlight operators. Successful operation of the system depends upon the proper functioning of each link. Sound locator readings of



FIG. 2. LATEST TYPE OF 60-INCH SEARCHLIGHT WITH DISTANT CONTROL

themselves are of no value without proper correction for sound lag and wind. Sound locator readings are of no value if the operators are poor listeners, have poor binaural sense, or are careless in "centering." A searchlight that is not easily controlled or does not have proper scales will cause poor results and possible failure of the system.

At the present time we have no thoroughly satisfactory prediction device. Approximations are made which cause errors of varying magnitudes. The devices used are crude. There are very few, if any, well-trained listeners. No accurate means for testing the ears of listeners are available. There is very little knowledge of acoustic principles among the personnel, so that the limitations of the devices are not always thoroughly comprehended. Mechanical imperfections may be found

in the sound locator, although many of these have been eliminated in a later model than that found in most of the regiments. The searchlight, in many cases, does not control easily; much improvement has been made in a model recently developed.

Often those in the field become impatient with the equipment that is placed in their hands to use. They feel that with little effort they could make much better devices; the faults of the device before them are so evident that certainly the man who designed it had no brains. The problem of sound locator development is only one of many that are being carried on by trained personnel who are making an earnest effort to produce what the man in the field wants. It is an uphill task; conquest of the technique involved is frequently not the only battle to be fought. Those in the field must cooperate with the development staff on any project, provide constructive criticism, and try to understand the functioning of a device before demanding more of it than it was designed for. Perhaps the point criticised has already been corrected in another model.

There are certain fundamental limitations in the sound locator problem and these must be appreciated in order that too much will not be expected of the instrument. The first of these deals with sound lag. Sound travels through air at the rate of 1100 feet per second as compared with the travel of light of 383,000 miles per second. Sound from an airplane five miles away then takes 25 seconds to reach the sound locator and in this time the airplane can travel more than half a mile. Obviously, a considerable change of course may be effected in this distance. However, an aviator is not aware of his observation by sound location and is not apt to change his course on a long flight. Changes in course by such heavy types of machine as laden bombers are affected only gradually. But there is no way of overcoming this inherent drawback to the sound locator so we can never look for it to be as efficient as an optical instrument.

The accuracy of location by optical instruments can only be roughly approached in sound location. Again, light waves are exceedingly minute whilst sound waves are long, in the case of low frequencies even ten feet and more in length. On this account sharp focusing is impossible and the laws of refraction and reflection used in optics fall down. Hence the determination of a "sound center" is only approximate and locations within a degree are good. And inasmuch as a searchlight beam has considerable width this degree of error does not interfere with the usefulness of the instrument.

Sound locators must always be large compared with visual observation instruments, again because sound waves are long compared with light waves. However, the proportions of the sound locator are equal

to those of the searchlight with which it operates and it is as mobile as the light.

There are those who advocate replacing the sound locator for night observation with some other means. The problem of sound lag and wind, the inaccuracy of the device and its cumbersomeness seem very good arguments for throwing it into the discard. But if its limitations are fundamental, so is the need for it fundamental. For purposes of perception Nature provided us with, first of all, the eyes. Sight is the most useful and most important of the senses. Optical instruments



FIG. 3. EXPONENTIAL SOUND LOCATOR, T-1. TRANSPORTED ON CLASS B TRUCK

are the most beneficial to mankind for increasing his perceptive powers. A large amount of our enjoyment is obtained through seeing things, and the principal activities of mankind are carried on during daylight hours when things can be seen.

But the second sense in importance for purposes of perception is the sense of hearing. The ear is an extremely sensitive organ and its functioning is as interesting as that of any other part of the body. Sound waves begin to affect the ear at the tympanum or drum, from whence the sound energy is transmitted through the three small bones forming the ossicular chain, to the window of the inner ear, or cochlea, so called because it is shaped like a snail shell. The inner ear is no larger than the end of one's small finger and yet herein are contained hundreds

of hair-like rods which perform the analysis of the complex sounds that are received by the ear. The conductor of an orchestra can pick out amidst the complex sound of many instruments any one instrument to which he may desire to pay specific attention. Speech and other sounds are analyzed for quality through the agency of these tiny rods, whose length is of the order of that of light waves. Much more able in the analysis of sounds is the ear than its rival the eye in being able to analyze light. No eye can see the various colors that go to make up any given complex color before it. No such complexity of structure



FIG. 4. CONVOY SHIPMENT OF SOUND LOCATORS

exists in the eye as in the ear. The whole act of hearing is complex from the instant the sound wave leaves the source to the time it registers on the brain its intensity, quality and condition of phase at the two ears.

Sound plays a much more important place in daily life than is ordinarily supposed. Much pleasure is obtained in listening to music; displeasure and even pain arise from discordant or loud sounds. Sounds often serve as warnings; the quality of sounds determines the kind of object from which the sound emanates; the direction of an object is obtained by sound. How valuable is sound to a blind man! I cannot, then, imagine that acoustic means for observation can ever be safely discarded for any other for the purpose of replacing visual

means when the latter will not function. The value of acoustic instruments may be augmented by other means but not replaced.

The question has been asked: What will happen when the airplane becomes silent? The airplane will be made silent no sooner than it will be made invisible. Sound results from a display of energy. A terrific amount of energy is used to force an airplane through the air. Much of this goes into the air medium and becomes a source of sound. Engines may be silenced but not the turbulent air about a propellor and moving parts of a plane.

The study of acoustic devices has commenced in earnest both for commercial purposes and for military use. Acoustics are to play an important part in military science. Sound ranging, sound locating, and sound warning instruments are to become part of the regular equipment. By patient cooperation, success in this field will be assured.

There are few instances in history where war was forced on a strong nation, although some nations with unbalanced strength have sought war. On the other hand, there are numerous instances of war seeking weak or unprepared nations.—
John W. Weeks.

Airplane Observing for Antiaircraft Fire

By LIEUTENANT RALPH W. RUSSELL
61st Coast Artillery

EDITOR'S NOTE.—*The author is an expert observer and has probably had more hours in the air during the past year than any other officer not on a flying status. He writes from experience.*

AIRCRAFT MOST COMMONLY USED FOR TOWED TARGET MISSIONS

PRIOR to May 22, 1926, the Martin bomber was used almost exclusively for towing targets for antiaircraft artillery firing by the 61st Coast Artillery, Fort Monroe, Virginia. The plane is large and roomy and one on which the largest of sleeve targets has practically no effect. There is ample space for the pilot, crew, chief, radio operator, tow-line reel operator, and observer. With the type of reel that is being used, the entire tow line has to be wound in by hand which, roughly, is a twenty or thirty minute job for one man. The reel is operated from the rear cockpit and it is quite possible for one man to operate both radio and reel, but not most satisfactorily. Observing has been tried from the pilot's seat, from the rear cockpit, on the wing, and from either of the two engine nacelles. It is believed that, of all these positions, the engine nacelle is best suited for observation work. there is plenty of room and the view of target is not obstructed by the rear of the fuselage and tail of the plane as is often the case when observing from the rear cockpit. To a certain extent the observer is protected from the wind and in case of necessity for jumping it would be very easy to clear the ship from the engine nacelle. However, information has been received that the War Department has issued instructions prohibiting the removal of parts of the plane for the purpose of providing a seat for the Artillery Observer. The cover of the engine nacelle must necessarily be removed if the observer is seated there.

Various types of aircraft other than the Martin bomber have been tested for the towed target work. From the point of view of the aerial observer, the bomber is superior to any other type of airplane for towing targets. A new type of reel attached to a D. H. plane has been tested. Under the fuselage at the rear seat is a small propeller (about one foot in diameter) that runs idle. The power of the propeller is derived from the windage of the airplane's propeller and speed of the plane. The inside of the rear seat is equipped with a clutch with which

the power of the small propeller can be transmitted to the tow-line reel, thereby winding the tow line in. There is also a brake that must be released before connecting power of the propeller with the reel. The brake must be on at all times except when letting out or taking in the tow line. It is believed that this type of reel, after it has been in active use, will

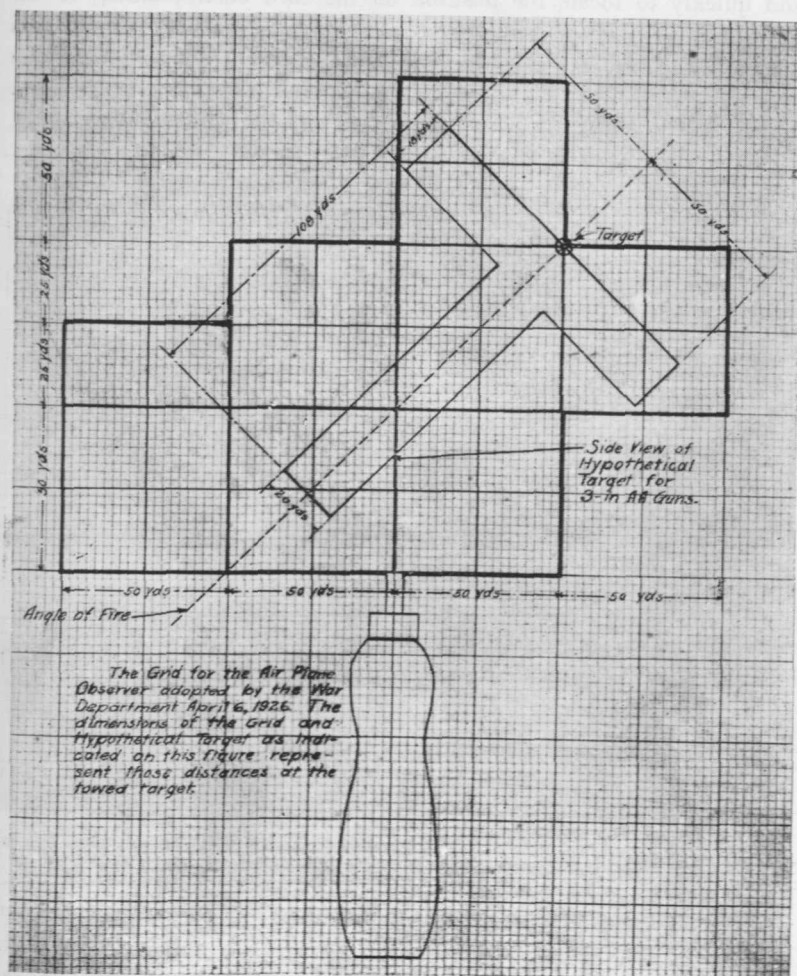

FIG. 1

prove to be very satisfactory because of its ability to take in two thousand feet of tow line in approximately two minutes. However, when attached to the D. H. ship it must necessarily be operated by the observer who is seated in the rear seat. Observation from this position is not the best and space is very limited.

USE OF THE GRID AND PLOTTING BURSTS

Changes No. 2, Coast Artillery Memorandum No. 6, April 19, 1926, authorizes the use of the grid shown in Fig. 1 for airplane observing. The irregularity in the shape of the grid enables the observer easily and quickly to locate the position on the card corresponding to the position in grid at which the burst fell. Yet it is not believed that this feature was taken into consideration when this grid was adopted. The grid was designed with a view to reducing its size for ease in observation and at the same time to permit the plotting of all bursts which might plot as hits.



FIG. 2. OBSERVING FROM THE REAR COCKPIT OF A MARTIN BOMBER. THE TAIL OF THIS LARGE SHIP IS VERY OBSTRUCTIVE TO THE VIEW OF THE TARGET FROM THE COCKPIT

The observer being unable to plot all the shots because many occur outside the grid, it is obvious that a burst which he might plot as, say, No. 3 might actually be burst No. 7 on that particular course. Therefore, it is necessary to take the time on all bursts that are plotted so that the airplane observer's data can be tied in with that obtained on the ground.

The grid should be attached to the neck of the observer by means of an adjustable strap. The distance of the grid from the eye should be as many inches as there are hundreds of feet in the tow line, *i. e.*, for a

tow line 1800 feet long, the distance should be 18 inches. Each large square of the grid then represents 50 yards at the target and each small square 25 yards. With this length of strap on grid and a tow line 1800 feet long, one inch on the grid represents thirty-three and one-third yards at the target. The grid is held so as to have the target at the position indicated in the figure. The grid is held in the left hand (for a right-handed observer).

Plotting is done on cards on which is drawn to scale the figure of the grid. A convenient size for the card is 4"x 8". The card is strapped to the left forearm by means of rubber bands. A split-second stop

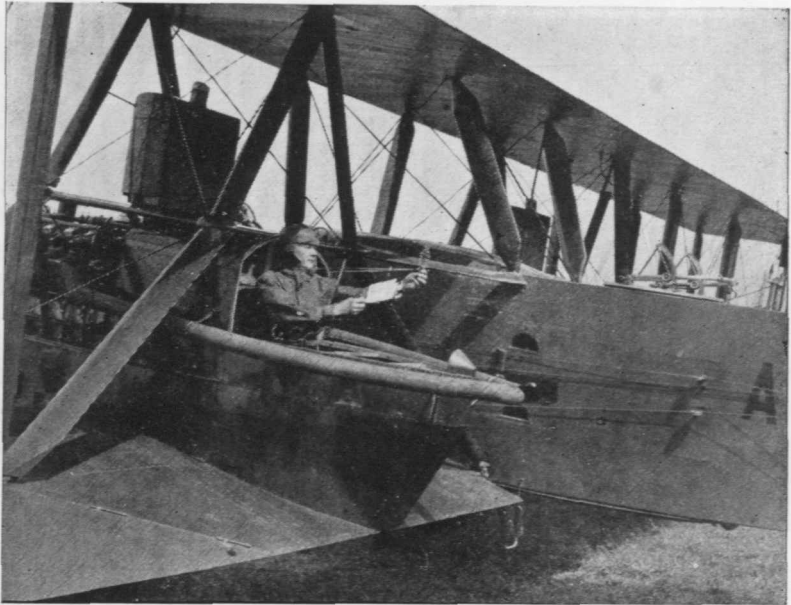

FIG. 3. OBSERVING FROM THE ENGINE NACELLE OF A MARTIN BOMBER. ON THIS PARTICULAR PLANE EXTENSIONS ON THE EXHAUST PIPE LEAD THE CASES PAST THE OBSERVER

watch and a pencil is carried in the right hand. At the beginning of each course the watch is stopped and both second hands are brought to zero. When the burst of the first shot on each course occurs regardless of where it occurs the main stem is pressed, starting both second hands. When the first burst occurs in the grid the small stem is pressed, thereby stopping one second hand. The time of the second hand that is stopped is recorded then the small stem is pressed which at this time will cause the stopped second hand to jump to the time of the running hand. The same process is carried out for all other bursts falling within the grid. A new card is necessary for each course. The courses

are flown until signal is received from ground either by radio or panel signals to go to machine gun course or to go home.

OBSERVATION FOR SEARCHLIGHT TARGET PRACTICE

The method practiced by the 61st Coast Artillery (A. A.) for searchlight tests and target practices usually requires the use of two Martin bombers with an observer in each. The mission of the bombers is to make an attack and drop bombs on certain objects. Flares are used in place of bombs. The planes at different altitudes make their attack over a known sector and fly a zig-zag course to the objective. Several attacks by each ship are usually made during each practice.



FIG. 4. OBSERVING FROM THE REAR SEAT OF A D. H. PLANE. THE TAIL OF THIS PLANE BEING SMALLER THAN THAT OF A BOMBER, OBSERVATION IS LESS DIFFICULT

The equipment used and the data obtained and recorded by the observer in the ship are as follows: A thin board about 6"x 15" is equipped on the left end with an altimeter, on the right end with a large watch, and in the center with the cards on which the data are recorded. Before each practice the watch is synchronized with the standard time. The data recorded by the Artillery observer is as follows:

- a. The altitude and time of each short flash of a searchlight beam across the plane before it is actually picked up and held in illumination.

b. The altitude and time of the beginning of effective illumination.

c. The altitude and time when effective illumination ceases.

d. The altitude and time each flare is dropped and the approximate location.

In cloudy weather, when doing night flying for searchlight drill, the observer's problem is quite complicated. When the plane is under the clouds and in effective illumination, observation from the plane on the ground objects is absolutely impossible. The observer under these conditions is completely blinded when in the intersection of several

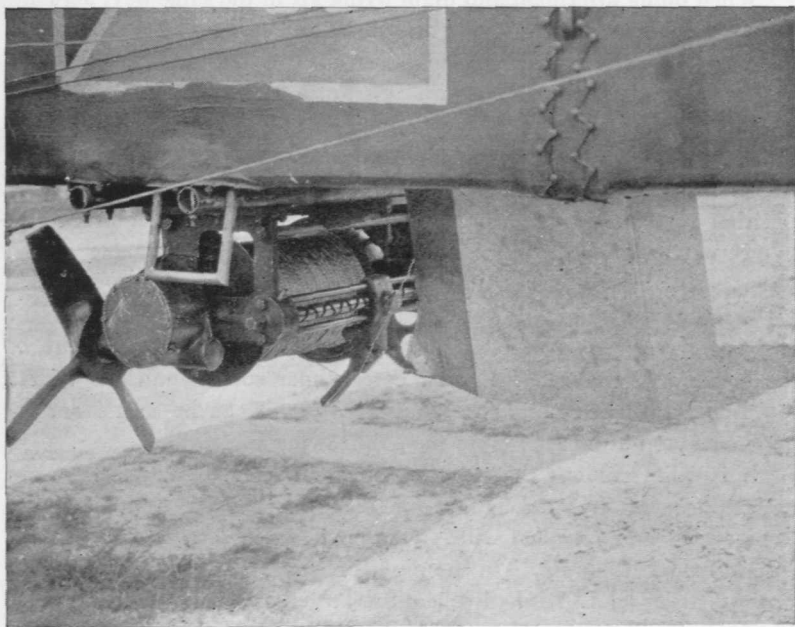

FIG. 5. THE TOW-LINE REEL UNDER THE REAR SEAT OF A D. H. PLANE. NOTE THE SMALL PROPELLER, ABOUT ONE FOOT IN DIAMETER, AND THE TIN CHUTE IN REAR THROUGH WHICH THE TARGET IS PUT OUT

beams. The effect of the illumination as seen from the plane is very spectacular. The entire space above and about the plane is brightly illuminated, and when passing through the clouds while still in the searchlight beams, the whole universe seems ablaze and absolutely nothing can be seen. This is a most unsatisfactory condition for the pilot and observer. Keeping the plane on an even keel at such times is most difficult. When realizing that a light beam could not be seen if there were no particles or objects to reflect the light, it is easy to

imagine the brilliancy of the reflection on the particles of moisture in the clouds.

COMMUNICATION BY RADIO AND PANEL SIGNALS

Radio communication between the towing plane and the antiaircraft regiment should be used. Panel signals may be used very satisfactorily if the panels are large enough and not placed too close together. Of course, it is quite necessary for the airplane crew to familiarize themselves with all signals.

DIFFICULTIES INVOLVED IN OBSERVING

When doing afternoon and night flying all in the same day, amounting to about three hours in the afternoon and two hours at night, for one observer only, it becomes very tiresome. As a rule one pilot does not fly on an afternoon and a night mission in the same day.

When observing from the most convenient place on the bomber, *i. e.*, the engine nacelle, there is an exhaust pipe on each side and within twenty inches of the observer's head. The gas, smoke, and noise at this position is the worst. It is impossible even with the best ear protection to prevent the noise from affecting very seriously the hearing of the observer for some time after each mission.

In cloudy weather, or even at times when there are just spots of clouds through which the ship is passing from time to time, many of the bursts will be lost. In many cases under such conditions with a tow line 1800 feet or more in length, the target can be seen from the guns and yet not be seen from the ship towing it.

It is quite obvious that for the various missions conducted by an antiaircraft regiment throughout the year, all kinds of weather conditions are to be contended with. One occasion in particular will to a certain extent illustrate. On the night of November 13, 1925, the 61st Coast Artillery (A. A.) had scheduled target practice at Grand View, Virginia. The weather was cold and stormy and the entire day's flying amounted to about six hours. The observer was located in the engine nacelle in rear of the right motor. The plane was at an altitude of 5000 feet and one mile out over the sea when the crank shaft of the right motor broke just in rear of cylinder No. 2. The propeller came off and crippled the right wing very seriously. There was, at that altitude, a fifty-mile per hour gale blowing out to sea at an angle of about 45 degrees with the beach line at that position. The pilot with his excellent maneuvering, assisted by two flares which he released, finally brought the plane to the beach against the wind in a spiral with only one motor running. The accident occurred just as the bomber was getting on the gun course and before any firing had taken place.

Athletic Organization and Management*

I. INTRODUCTION

By CAPTAIN H. MCC. COCHRAN
Coast Artillery Corps

THE subject of athletics is one in which all officers should be keenly interested, for athletics are or should be a vital part of the Army.

Turning to history we find that in ancient Greece the Olympic games consisted almost entirely of exercises of a Spartan type, that is, exercises that tested endurance and strength with an especial view to war. The Olympia always remained a central expression of the Greek idea that the body of man has a glory as well as his intellect and spirit, that body and mind alike should be disciplined. Since that time athletics have continued to modern times in one form or another. It has been said that the battles of England have been won on her playing fields.

The United States has always been foremost in athletics, as evidenced by our almost continuous winning of the International Olympic Games and the popularity of all sports. It was therefore something of a shock to find that, when the men of military age were examined under the Selective Service Act, one-fifth were found to be physically unfit and that another fifth were physically defective to such an extent they were available only for limited service. This was contrary to popular belief, which thought of this country as the best educated, both mentally and physically, in the world. This belief had probably grown up from the large interest, particularly in baseball and football, shown by the crowds that attended these games throughout the entire country.

This tendency for the large majority to display their interest in athletics by comfortably sitting and watching a few selected athletes perform is also prevalent in the Army. This tendency may be counteracted in the Army by means of group games, as will be brought out further.

Practically any form of athletics tends to develop teamwork, improves the good judgment of the player, and furthers his ability to make quick decisions. It is hardly necessary to point out how important these factors are to a soldier. Furthermore, an organization that has a successful athletic team (and there is no reason why any organization should not be able to turn out a good team in at least one sport) develops an *esprit de corps*, a confidence in itself, that is invaluable. A point that should be brought out at this time is that all soldiers should

* Committee Problem No. 9, Coast Artillery School, 1925-26.

be in good physical condition at all times, so that if ordered into the field they will be able to endure the hardships they will encounter there.

We have tried to show that athletics have always been a concomitant of military training, that probably one-half of the men of military age in this country are physically unfit for military service, and that athletic sports are a means to ensure physical fitness. We shall stress the point that more time should be allotted to athletic sports, that better supervision should exist, that means should exist whereby excellent coaches are available in all sports, that is, coaches with both theoretical and practical knowledge. We shall also discuss the details of organization, of management, and of finance.

II. ATHLETIC ORGANIZATION

By CAPTAIN E. A. MANTHEY
Coast Artillery Corps

Ideas as to the organization and administration of athletics differ. We therefore submit for your consideration some ideas which have seemed logical, practicable, and productive in the presentation of a subject of such wide scope and so many possible angles of development.

The vital need of athletics to our army can more forcibly be presented by quoting from *The Third Corps Area Gazette* of December, 1925.

THE PLACE OF ATHLETICS IN MILITARY TRAINING

By MAJOR GENERAL DOUGLAS MACARTHUR

Until the World War, armed conflicts between nations had been fought by comparatively a small fraction of the population involved. Early in the War it was realized, to the astonishment of both sides, that the professional armies upon which they had relied were unable to bring the combat to a definite decision. It became evident, due largely to the elaborate and rapid means of communication and transportation which had grown up in the past generation, that national communities had become so intimate that war was a condition which involved the efforts of every person in the countries effected. War had become a phenomenon which truly involved a nation in arms. The rôle of the professional army has thus become that it shall be the source from which the trained instructors and leaders are drawn for the great citizen army to be raised in the emergency. In the peace-time training of the Regular Army we must therefore keep this point constantly in mind.

While I was in command of the United States Military Academy there was inaugurated what is believed to be one of the most complete physical regimes to be found in any institution in the world. The Cadet is made to feel each day mutual response between the mental and physical sides of his nature, using the body to teach the mind and the mind to teach the body. The success of the scheme adopted may be judged from the results of the first trial year of compulsory mass athletics when out of a total enrollment

of not more than 950 cadets, 641 were individually coached until they were able to play in intramural match games of football, 641 went through the same process in soccer, 550 in lacrosse, 337 in tennis, 263 in basketball, 240 in baseball, 100 in track and field, 25 in golf, and 16 in polo. In addition there were compulsory indoor activities such as swimming, boxing, wrestling, fencing, gymnastics, and riding.

The practical relation of athletics to military activities is apparent. Consider, for example, the relation of boxing to bayonet fighting; of wrestling to hand-to-hand fighting; of swimming to the frequent occasions in battle when soldiers, even in full equipment, are required to cross streams; of the tactics of football to the tactics of the platoon; and of the quickening games to the conduct of the advance of skirmishers.

There is, moreover, a very practical relation less apparent than those mentioned but none the less real. I refer to the development of the correct mental attitude in the soldier. He must be quick-thinking, he must have confidence in himself, his morale must be high, he must be conscious of a mental and physical preparedness and poise. Above all he must have the aggressive spirit that knows not defeat but ever presses on doggedly and offensively to the uttermost limit of his strength.

Soldiers thus prepared enter battle with light hearts. They achieve their purposes, and they live to fight another day.

While in the days of long ago individual combat was the thing, today the tendency is toward teamwork. In the yesterday of sport the super-development of the individual was the goal. Today, it is the coordinated effort of the team. Even the great "Red" Grange needs his interference to rip off yardage on the gridiron.

Teamwork means the development of more men; and right here organization enters as a prime requisite to successful athletics. This is an age of organization, and there are examples without number where the brilliant efforts of the individual are submerged because of the lack of coordinated effort by his fellows. In support of the essentiality of coordination in athletics *within itself and subsequently between athletics and military training*, we quote the following:

RECREATION MEMORANDUM } Headquarters Third Corps Area, United States Army,
No. 14 } Baltimore, Maryland, September 10, 1925.

ATHLETIC POLICY THIRD CORPS AREA

* * * * *

2. Athletics have lately assumed a new significance in military circles. Formerly, in a large measure, a matter of pure recreation and amusement, it has now become intimately and vitally a part of military training. It is recognized that the aggressive spirit essential to the soldier is not to be attained by passive indulgence in calisthenic exercises nor by a non-participating interest in sports. The exacting requirements of modern combat, throwing the individual soldier often upon his own responsibility, demand those personal characteristics which are created and nurtured by active participation in competitive games.

3. It is the desire of the Commanding General that athletics be so conducted as to permit, in so far as practicable, every enlisted man to participate in some competitive sport. It is especially important that every new recruit be given athletic training, not only to increase his combat efficiency but also his morale and his contentment.

Army athletics are logically divided into two classes:

a. Those which seek to develop the greatest number of men possible in order that the great good to be derived from sport might be distributed throughout one hundred per cent of the command.

b. Those which seek supremacy in competition for the purpose of developing pride of organization, *esprit de corps*, and fill the various headquarters with silver cups and trophies, referred to with a tinge of pride by officer and enlisted men alike.

Let us consider the first class—the “development” phase, rather than the competitive. Into this class fall the company and regimental teams. Naturally, the regiment must organize and supervise the company teams. The post, likewise, must organize the regimental schedule. In both of these schedules the prime object should be to interest, as actual participants, the greatest possible number of soldiers. Ability in these contests should be subjugated to development. Since the spirit of competition must impregnate all athletics, it being the basis of ultimate success, games which permit the greatest number of men to become members of the squad should be chosen. Substitutions should be regular and frequent. A favorable compromise between the greatest number of participants and the greatest number of victories—always maintaining a favorable ratio of both—is the ideal here.

We believe that there are two games which should be considered as vital to every athletic program. They are volley ball and soccer. In both of these games there is almost unlimited opportunity for general participation. In a recent conversation with the Third Corps Area Recreation Officer, Colonel J. P. O’Neil, who was quarterback for three years and Captain at Notre Dame, stated: “I would relegate football and baseball to second place in army athletics and give the primary place to sports such as soccer and lacrosse in which large numbers of men can participate. I would turn the entire parade ground into an athletic field for these sports. A study is now being made with a view toward having these sports promoted.” On a soccer field you can pit twenty men against twenty if the field can accommodate them, and this without spoiling any of the aspects of the game. In volley ball a dozen men may participate. It is strange that with these apparent possibilities, so little attention is given in inter-company or inter-battery contests to these sports.

A suggestion worth trying is to designate as coaches for the battery teams those who have qualified as "experts" and to prohibit them from participation. That niche in the development-phase of athletics, which the "expert" would otherwise fill, is now open for claim by a novice in his organization. We have, however, known regimental commanders who objected strenuously to having "stars" from their battery teams taken from inter-battery contests for development of a regimental team. They likewise do not favor giving up their regimental "stars" for a post team. But if you analyze this spirit you will find that their motive is based entirely on the ambition to win, not to develop. We believe that there is a proper place for this spirit, but it is not in the inter-battery and inter-regimental leagues.

There are many men of mediocre ability who are not good enough to play on the regimental or post teams but would be "stars" on the battery teams. If you permit the super-player, who is to "make" the post team, also to play on the battery team and the regimental team, then his brilliance outshines that of the mediocre men. Keep the proven "star" for your competitive athletics alone and let the men of less ability compete with men of their own caliber, and you will distribute the glory as well as the training and fan the flame of enthusiasm within the lower units.

Track athletics always furnish a great field for development. Any number of men can participate, and here, also, if you take the established "10-second man" out of competition in the battery teams, you distribute your trophy cups throughout your regiment and post and produce a widely felt influence of athletic supremacy.

We were favorably impressed by the program of the Harbor Defenses of Balboa for the calendar year 1924, which outlines progressive athletic training throughout the year. This represents the ideal in organization of athletics. It prescribes swimming and track meets, stating what events will be held at the meet and how many points each will count. Let us analyze the benefits of such supervisory organization.

The first meet of the year will probably be an experiment. However, in this meet, John Smith beats Bill Jones in the 100-yard dash by a scant foot. Perhaps Ikey Cohen wins the 220-yard dash by a "nose" and is thankful that he was not of Irish parentage, which would have taken away his physical advantage.

Bill Jones, who lost the dash by a foot says, "I can beat John Smith with a little training," and he buckles down. He starts right in training for the next periodic track meet. Pat O'Houlihan says that nobody from Jerusalem, Hoboken, or other way points can beat him again in the two-twenty, and he also is interested.

Would all this happen if there was not a definite date set for the next meet and if they did not know positively and definitely whether there would be an opportunity to stage what athletes call a "come-back"? We think the advantage of a well-thought-out annual athletic program, involving the lower units of the organization, should be obvious to every one. But how often do you find it today?

Now let us turn to the "expert," who, up to this time, appears especially discriminated against. There is a place for him, and his place, according to our theory, is on the post team.

First let us consider the reaction of a good post athletic team on the men of the post. Essentially, this reaction is ninety per cent morale. If we were going to pick a post team of approximately twenty men on the squad, out of 1150 men at Fort Monroe, strictly on a basis of the benefit from athletic training to these twenty men, we should abolish post teams. The proportion which receives this benefit, as compared to the proportion of men on the post, is too small to demand even passing consideration. Therefore we believe it obvious that a post team must be organized strictly as a morale asset to a post, *not* as an athletic developer.

Soldiers on a post which has a winning athletic team support that team, talk athletics, take greater interest in athletics themselves in hopes of replacing some of the stars when they are discharged or transferred, and are more likely to reenlist than on a post where, to use the soldier expression, "the chief sport is wielding the shovel on fatigue." We honestly believe that a good athletic team is worth more to a post in getting recruits than a dozen posters announcing loudly "The Army Needs You," or "Join the Army and see Hawaii or Panama."

Also consider that, through a good athletic team, the Army is brought into contact with the civilian element. A well-handled, well-trained athletic team performing before the civilian community is a tribute to army training and an inducement to enlistment. On this basis let our army teams always be *good* teams. What is a greater tragedy than to have, say, the Norfolk baseball or basketball team play Fort Monroe, whip it unmercifully, and have the citizens go home from the game saying, "Well, it is only a soldier team anyhow, not even good practice for our boys." The team is not invited to play again and the contact between the Army and civilians, which is so widely sought in order that the public may know more about just what the Army is doing, is lost.

Now as to the old subject of officers playing on post teams. War Department regulations permit only one officer to play on a team. Undoubtedly the men who formulated that regulation thought it out carefully before publishing it, and perhaps they had reasons which

are not apparent to us all. But to our mind, the chief requisite for position on a representative post team should be athletic ability. All advantage should be given the enlisted man, of course, but when the difference between an officer and an enlisted man will make the difference between the corps area championship and an "also ran," there is not much doubt as to the benefit to the post. We do not believe in corps area super-teams. These teams have no place in army athletic programs. They should be like the mythical "all star" teams—paper organizations. It is of vital importance to have a good post team, and interpost contests for the corps area championship should be the peak of competition. There is such a thing as too much, as well as too little, competition.

Adherence to a definite system of training and carefully planned schedules as outlined above will bear its fruit in the clear-eyed, alert, head-erect attitude, the well-coordinated limb-movement and snappy quick action of the men you command—men whose physical destinies in a large measure are yours to improve and mold. The form of athletics of paramount service to our military establishment is the one that develops the traits of denial, resignation, determination, and loyalty combined—namely "Stoicism"—the quality that carries the footsore, blistered, parched, and weary to the end of the day's march,—that quality, which, with hunger gnawing at his vitals, with feet plowing through brush, slush, and muck, with vermin and scant clothing, with bruises and wounds, sub-consciously carries the man on to his objective—with the determination "I will" surging through his veins and bursting from his lips with the last spurt.

III. MANAGEMENT OF ATHLETICS

By LIEUTENANT V. W. WORTMAN

Coast Artillery Corps

Athletic management is the skillful use of all available means to accomplish the objectives of athletic training. Its objective in the Army is the orderly and successful execution of the athletic program. The necessity for management is occasioned by the increase in time and attention devoted to this activity. Schools were and still should be conducted for teaching the theory and practice of coaching various forms of athletics. All officers are instructed by the War Department in Circular No. 69, 1924, and various others, to develop any athletic ability or talent they may possess, in order that they may better perform their duties and obligations in connection with this phase of military activity. Due to the vast amount of time and money now devoted to athletic training and the necessity for reaching and develop

ing each member of the command, it behooves the officer personnel, in these days of cruel economy, to give the matter of management serious consideration.

The exercise of intelligent management of athletics requires a careful study of objectives sought. In our Army the objectives should be: the physical development and amusement of the individual; the development of the competitive instincts of the individual; the development of the principle of team work; the recreation and relaxation of the entire command.

To accomplish these four objectives army athletics are divided into two distinct types:

The objectives of the first type are: the physical development and amusement of the individual; the development of the competitive instincts of the individual; the development of the principle of team work.

The second type has for its objective the amusement and relaxation of the entire command.

The first objective is of paramount importance in spite of the fact that little or no attention is devoted to it by many posts. Its accomplishment involves all members of the command and, naturally, it deserves the major portion of our attention. The day of the specialist in army athletics is a thing of the past. We must put the pressure where it belongs. What we want to develop is a strong, vigorous, athletic personnel and not a few highly trained specialists. All peace-time activity should have as its objective preparation for war. And if this be true, it follows that our athletics should be so managed as to render the entire personnel physically and instinctively fit for duty on the battlefield at all times.

In order to do this all men should be required to participate daily in competitive athletic games which bring into play as many sets of muscles as possible. Group games are ordinarily better adapted to the accomplishment of the first objective due to:

The limited number of athletic fields and courts available;

The limited time devoted to athletics;

The great number of men who must participate;

The absence of sufficient commissioned personnel properly to supervise so many diversified forms of athletics.

Modified soccer and volley ball, together with many other group games, meet the requirements most satisfactorily. Fifty, or even a hundred, men may engage on either side in soccer at one time, and of course, that affords an opportunity for the play of an entire battery or two of them if necessary.

The second objective—the amusement and relaxation of the entire command—is accomplished by competitive play between teams of selected volunteers. It is of considerably less importance than the first. However, it has its place in the athletic program and should not be neglected. In accomplishing this objective an opportunity is afforded to use the volunteers most proficient in the event. These men should play on the battery, regiment and post teams for the amusement and relaxation of the entire command. Due to the object and method of their selection they should represent the best talent on the post in their respective events. This objective is comparatively easy to accomplish if the proper methods of management are employed, and when I say management I have in mind the management exercised by the Athletic Officer, Team Managers, and Coaches.

Considering these two distinctive types of athletics it is apparent that each must have the management which enables it to accomplish its objective, and, due to the difference in their nature, the qualification requirements of the individuals who manage them will be slightly different. The team members in the first type of athletics are selected with a view to balancing the playing ability of the team, whereas the selection of team members in this second type to represent the battery, regiment, or post in competitive play for the amusement and relaxation of the command is a much more complicated problem.

There is nothing difficult in connection with coaching and managing mass athletics or group games if you understand the few simple rules of the game and show the members of your organization that you are interested in it, and that it is being played because of your desire to develop in them the soldierly qualities: alertness in mind and body; physical strength and courage; tenacity and the competitive instinct. Moreover, by performing your duties in connection with this activity in a wholehearted and enthusiastic manner, you develop, by precept and example, that last and most important quality of a soldier—fidelity.

The management of the second type of athletics, and especially the management exercised by the coach, is considerably more difficult than the management of the first type. The rules of the games are more complicated; better coordination and team work are required, more attention must be given to conditioning the members of the team, and more time must be devoted to practice. In view of these requirements, the coach should be a player of unusual ability and should possess a thorough knowledge of the rules and mechanics of the game.

The objective of this type of athletics is, as stated, to produce interesting play for the whole command. Therefore, the players selected for such competitive sports as baseball, football, and basketball must not only be the best available men in the command in their events, but,

most important of all, *they must be volunteers!* Still, if these teams are properly to perform their function they must be highly conditioned, thoroughly instructed and drilled in the individual and combined offensive and defensive tactics of the game. The playing of such games, when carried on to the extent required by the average post schedule, becomes more of the nature of work and duty than pleasure, as the training requirements are and have to be somewhat severe. It follows then that the best management of a team will be that management which can carry through the most thorough and severe training program without destroying the volunteer spirit of the members of the team. In army athletics this responsibility generally falls on the coach and affords an opportunity for the exercise of all the tact and good judgment he possesses. I think most of those who have shouldered this responsibility can vouch for that.

In managing the second type of athletics we should not lose sight of the fact that the volunteers—the men who enjoy and are willing to take part in athletics, must remain the sole source of our team members. We may try to build up interest by offering prizes, rewards, and special privileges but, after all is said and done, these alone are not sufficient stimuli. In order to put their heart and soul into the game the players must play the game because they like it. *They must be volunteers!* Any management which loses sight of or disregards the principle of voluntary participation in recreational athletics will not succeed, because enforced athletics for recreational purposes are a failure.

The selection of the Athletic Officer should be made by the Commanding Officer after carefully considering the qualification requirements of the officers available. The following are some of the qualifications he should possess.

He should be interested in athletics.

He should realize the necessity for athletic training.

He should be aggressive and tactful.

He should have had experience as an organization commander.

He should have a fair theoretical knowledge of the major sports.

He should possess organizing ability and judgment.

He should be able to pass judgment on the playing ability of team members by observing their play.

He should have had practical athletic experience, but this is not absolutely necessary.

As Athletic Officer he is responsible for all athletic activities on the post. He is the liaison officer between the Commanding Officer, organizations, managers, coaches, the local Chamber of Commerce, and the

representatives of the press. His duties in connection with the responsibilities of his office are as follows:

- The preparation of the athletic program;
- The recommending of managers and coaches to the Commanding Officer;
- The securing of financial support from the Post Exchange, theater, and other sources;
- The purchase and distribution of athletic equipment;
- The preparation of the athletic fields and courts;
- The scheduling of games;
- The selection of officials;
- The securing of publicity through the press;
- The conducting of schools for group-game coaches;
- The supply of group-game rules;
- The awarding of trophies;
- The arranging of banquets for athletic teams;
- The recommending of men on the post team to be placed on special duty in the afternoon;
- The supervision of entertainments and receptions for visiting teams;
- The arranging for training tables;
- The securing of the attendance of one medical officer with emergency supplies during the post games;
- The collection of gate receipts;
- The administration of all athletic activities.

The team managers for the post teams should be appointed by the Commanding Officer upon the recommendation of the athletic officer. They should report to the athletic officer as his assistant for the management of the athletic teams concerned. Ordinarily, the team managers should be officers if sufficient officers are available. However, there are some enlisted men who can perform the duties very creditably. The qualifications and requirements for a team manager are as follows:

- He should be interested in the type of athletics he manages;
- He should be aggressive;
- He should possess the spirit of cooperation;
- He should have a fair knowledge of the type of athletics he manages;
- He should be able successfully to handle the team on trips away from the post;
- He should be able to interest prospective candidates in trying out for the team;
- He should be able to handle all matters of administration in connection with the team.

As an assistant to the athletic officer, the team manager performs all duties the athletic officer may see fit to assign to him. These duties

will, in all probability, be the major portion of the duties for which the athletic officer is responsible in connection with the team in question.

The team coaches for the post team should also be appointed by the Commanding Officer upon the recommendation of the athletic officer. Extreme care must be exercised in their selection, for they form the foundation upon which the athletic organization rests. The following are some of the qualifications a team coach should possess:

- He should be a player of unusual ability;
- He should be interested in the type of athletics he coaches;
- He should be thoroughly familiar with the rules of the game;
- He should be aggressive;
- He should have a thorough knowledge of the individual and combined offensive and defensive tactics of the game;
- He should possess tact and judgment;
- He should understand men;
- He should have a thorough knowledge of dieting and the conditioning of men;
- He should understand the advantages of a training table.

A book could easily be written concerning the duties of coaches, but due to limited time, we shall mention only the most important ones. They are as follows:

- The conditioning of the members of the team;
- The instruction of the individuals in the rules of the game;
- The instruction of the individuals in the offensive and defensive tactics of the game;
- The drill and instruction of the team in combined offensive and defensive tactics;
- The perfection of team work by systematic and thorough drills in play against the reserves;
- The securing of information, by the scouting method, concerning the style and tactics of play used by the next opponents on the schedule;
- The drill of the reserves in the foregoing style of play for use against the first team;
- The holding of the so called "skull practices" occasionally and the use of chalk talks to clear up the fine points of the game;
- The disciplining of members of the team while under his jurisdiction;
- The making of substitutions during a game.

The rewarding of athletic officers, managers, and coaches is a subject which should not be neglected if the best results are to be obtained in athletics. Many times officers are detailed in connection with this activity and, through their athletic ability, zeal, and enthusiasm, develop all-victorious teams. But, very much to their surprise, their superior performance is absolutely forgotten when the efficiency reports

are made out. No doubt this is due to thoughtlessness in some cases and a failure to appreciate the value of such duty in others.

To fail to recognize and reward superior performance on the part of your subordinates not only defeats the object of the efficiency report but indicates a failure to understand human psychology. This is the Commanding Officer's opportunity to indicate to these officers, and to the command, the importance he attaches to this phase of military activity. A careful consideration of this point in connection with the preparation of efficiency reports will have a very salutary effect upon the interest devoted to athletics in the command.

All battery officers should be thoroughly qualified to manage and coach all of the principal group games. These are the games which must be employed if each individual of the organization is properly developed physically. These are the games which must be employed if we develop competitive instincts. These are the games through which the principles of team work must be taught. And finally, these are the games upon which success in preparing men for victory on the battlefield will depend.

IV. FINANCES

By LIEUTENANT H. E. TYLER

Coast Artillery Corps

In discussing the financing of athletics we shall confine ourselves, for the most part, to the problems of a Post Recreation Officer, merely touching upon battery, regimental, and Corps Area finances. In order to clarify the subject it might be well at the start to see for what, in a general sort of way, money is necessary.

To begin with, there is the question of equipment—a very necessary and costly item. The average person has very little idea of the cost of athletic equipment. Let us consider a football team. It will take about forty good American dollars to put one player on the field completely equipped. For eleven men that runs the total up to four hundred and forty dollars and by the time the substitutes are provided for the total mounts to six hundred dollars at a minimum.

Then consider the playing fields or courts. Existing fields are constantly in the need of improvement or repair. Tennis courts require resurfacing, baseball diamonds must be groomed, football fields require marking out, basketball courts must be kept in good playing condition.

After a team is equipped and a place to play and practice is provided, there remain the incidental and running expenses. Traveling costs are high and, even though government transportation be utilized, there are extra meals to provide. Numerous small expenses occur that cannot be anticipated.

Let us now consider the athletic teams of a battery. There is just one source of money for battery athletics, and that is the battery fund. Every one is sufficiently familiar with the sources of income of this fund to allow their omission at this time. The battery commander purchases whatever equipment for his teams and for the use of the entire battery he believes desirable and the condition of the battery fund warrants. The equipment for group games is usually purchased by each individual battery. The cost of equipping the teams is their sole expense. Playing fields or courts are provided and maintained by the Recreation Officer and games are played with other similar teams at the same or nearby posts or with local civilian teams. In the two latter cases government transportation is used.

Just a few words in regard to regimental teams should suffice. They are usually conducted in one or the other of the following two ways. Battery equipment may be used or, on large posts where two or more regiments are stationed, the income of the Post Recreation Officer from the various sources may be distributed among the regiments, with a certain amount remaining in the Post Recreation Fund for strictly post activities. Thus, in this case, we find a Regimental Recreation Fund that is administered in the same manner as is described for the Post Fund.

Now let us see what the financial problems of the Post Recreation Officer are and how they are met. First, what are the sources of income? Each post differs, but all posts within the continental limits of the United States have twenty per cent of the net income of the War Department theater returned to them from Washington to be used for recreational activities. That helps, but, in itself, is never sufficient. Two evenings each month the theater may be utilized for boxing bouts, road shows, or other entertainments, all of the profits from which accrue to the post. If it be desirable to use the theater over twice a month for this purpose fifteen cents on each admission must be paid the United States Army Moving Picture Bureau just as though the scheduled moving pictures were shown. On some posts this may advantageously be done.

In our foreign possession conditions differ again. Here we find the theater under local control. All profits accrue to the post and a well-managed theater will not only provide adequate money for athletics but excellent pictures can be shown.

In some cases the small canteen usually found at the theater is operated by the Recreation Officer instead of by the Post Exchange. This is a very good source of income.

Of course, the Recreation Officer may always go to the Post Exchange Council for an appropriation. But how independent he feels

if he does not have to throw himself upon the mercy of this council, each member of which is tenderly nursing a company fund. Even though required to support athletics by regulations some Post Exchange Councils are very reluctant to do so. This selfishness on the part of a council should not be allowed. No reasonable request from the Recreation Officer should be refused.

In one place the formation of an athletic association was tried. Membership in the association was required of each officer and enlisted man with dues of fifty cents a month. However, as soon as the average soldier feels that he is being compelled to support athletics he resents it and loses interest. Therefore this plan is not feasible.

Let us now see where this money goes. The largest item in the expense column is the equipment, individual and team. Good athletic equipment is very expensive. To equip teams in all branches of sports with complete outfits is one of the many problems we find. How many uniforms are needed? What can I afford to pay for them? Will any special equipment be needed? These are some of the things the Recreation Officer must ask himself. If any one has any doubts as to the cost of outfitting a team let him glance through any sporting goods catalogue. One look will be sufficient.

Teams should be provided with the best equipment funds will permit. On most posts we find baseball, basketball, football and track teams to equip, and sometimes swimming, soccer, and lacrosse teams. Items of team equipment such as balls, bats, gloves, racquets, whistles, masks, and score books must be purchased.

Playing fields require constant attention. Improvements are always desirable and maintenance costs mount high. Labor is difficult to secure, due to the ever increasing shortage of men. Very little material of any sort can be secured from the quartermaster. What he has is being used to patch and repair tottering buildings. In other words the Recreation Officer must be prepared to pay for everything he gets.

Then comes the question of officials. Competent men may usually be found among the officers or enlisted men on a post and wherever they are available should be used, but often times for important or championship contests it is desirable to obtain registered A. A. U. officials at from five to fifteen dollars per game.

Help from the Corps Area is not forthcoming at the present time. Each Recreation Officer must work out his own salvation. Existing conditions must be studied and the Recreation Fund placed on a firm substantial basis. All possible sources of revenue must be made to yield the maximum amount and after the money is obtained each sport should be given its fair share. Each post is a problem in itself and must be so treated.

V. SUMMARY

By CAPTAIN H. MCC. COCHRAN
Coast Artillery Corps

We believe that athletics are one of the most important elements in the training of a soldier. We realize that with the present training programs there is very little time for more athletics. Notwithstanding this we believe that considerably more time should be allotted, even if other elements have to be sacrificed.

All officers and men should be interested in athletics. At the present time this is not so. Athletics are a secondary and, in general, only the Recreational Officer and the "stars" take an active part.

To achieve this interest group games are necessary. Calisthenics are passive, they do not develop an aggressive spirit, and the men do not display the needed interest to make them effective. Competitive athletics are necessary both to develop this interest and an aggressive spirit.

The idea of teamwork is essential for both athletics and military training. Properly organized athletics will teach men that teamwork is necessary to win. They will learn that the team does not depend upon the uncoordinated efforts of each individual but upon the coordinated efforts of them all. Once having learned this its application to the military team will be apparent.

We believe that games of the type of soccer and volley ball should be played rather than baseball and football. The object of Army athletics should be that all men engage in competitive sports. This may be accomplished by games of this type.

The efforts of batteries and other units must be coordinated. Proper supervision must insure that all units play the same games at the proper season. Further that good playing fields are available, that as good equipment as can be secured is on hand, and that competent officials are present so the game may be played as it is intended to be played.

To promote interest players of the expert type should be barred from inter-battery competition. Their place is on the regimental or post team. Inter-battery athletics are the means to furnish physical exercise to men of mediocre ability. The presence of experts on battery teams debars novices who will then receive no training; the presence of a battery team made up mostly of experts will discourage other batteries, not so fortunate, from displaying any interest.

An annual training program which gives full details as to dates and events is very helpful. It enables individuals and organizations to prepare themselves in adequate time.

We have stressed group games, because we believe that army athletics should develop all men. But a post team composed of experts has also a mission. It furnishes recreation to the command; if at all successful it heightens the pride of the men in their post and, just as important, it furnishes contact with the civilian population.

The coach should be an officer of unusual ability in both the theory and the actual playing of the game. He should be keenly interested in the game and should develop the same spirit in the players. It is believed that selected officers should be sent to schools to learn the proper coaching methods.

The men on the post team will be the experts and, preferably, volunteers, since enforced recreational athletics are a failure.

The Athletic Officer should be carefully selected by the Commanding Officer. The success or failure of the recreational athletics depends upon him. He should have practical athletic experience if possible but he must be able to organize and manager the various teams. Furthermore he must have the active support of the Commanding Officer and the other officers of the post. He must also feel that if he has had a successful season he will receive credit for his efforts.

It must be borne in mind that athletic equipment is very expensive, that maintenance costs of playing fields are high, and that there are a great many teams to equip. Realizing this the problem of financing is apparently quite serious.

At the present time post athletics must be self-supporting, as the large funds that were on hand in the Corps Areas at the end of the World War have been spent. The Athletic Officer has, then, only a few sources of income: the theater, the Post Exchange, and any entertainments or smokers that he can contrive. The batteries, of course, have their Company Funds but these are subject to many other calls. This paragraph has developed into a plea for money and this is usually the situation in which the Athletic Officer finds himself.

To be prepared for war is one of the most effectual means of preserving peace.—George Washington in Message to Congress, January 8, 1790.

A Plea for a Strong Antiaircraft Defense

By LIEUTENANT COLONEL D. M. F. HOYSTED
Distinguished Service Order, Royal Engineers

[Reprinted by permission from the *Royal Engineers' Journal*]

EDITOR'S NOTE.—Colonel Hoysted here discusses the great danger to the British Empire by attack from the air and the best means to combat it. Great Britain no longer can depend upon its fleet alone for defense. In future it also must have strong air forces and powerful antiaircraft defenses. The author dwells upon the feasibility of an air attack launched from airplane carriers. Readers of the article can hardly fail to consider an analogous situation for the United States, assuming that our fleets were to suffer defeat.

IT is a trite opinion, almost universally accepted, that the opening move in a future war between great powers will begin with a surprise blow dealt from the air with great concentration. In its application to these islands this opening attack will have a twofold object. Firstly, that of putting our naval and aerial forces out of commission before they can leave their stations; and secondly, of terrorizing the inhabitants as well as the defenders of the invaded territory. The last war was a crucial test of nerve, but the next will be far more trying.

The controversy as to the relative merits of aircraft and surface ships on the open sea is being thoroughly tested by the United States as well as ourselves; the ultimate outcome is still obscure. Aircraft enthusiasts declare that they have driven the Navy from the surface, while the Navy denies the aspersion with no little warmth. Be the result as it may, the initial process mentioned above is now generally accepted as a probability. Bombing planes will be able to bomb naval defenses and ships in harbor as easily as a battleship could shell them, while the faster type of plane will be used in the place of cruisers and destroyers for minor raids and attacks on shipping or unfortified towns and factories. These bombing planes will be protected by fighters and will be able to operate from a base some 250 miles from their objective. The day of the bombing airship is practically over, as such craft are too uncertain and unwieldy for use in large concentrations: the Allies backed the winning horse before 1914 and the German Zeppelin was beaten before the war began.

So far, the starting point for such an attack has been a land base, and if a line were drawn parallel to the eastern and southern coastline of these islands and at a distance of 250 miles, it would enclose any land area from which it would be possible to deliver the attack. More definite information as to the actual position of such a base will be gathered from the political situation of the moment.

So much for the land base, but what of the sea base? For aircraft can operate as easily over water as over land. So that in the future the blow may originate from either a land base or a sea base, or both, according to its aim and the situation of the objective. As a naval power it behooves us to consider the possibilities to which we might at any time be open.

Let us think for a moment of the possibilities of a temporary base on the water. Article VII of the Agreement for Limitation of Armaments lays down a total tonnage for aircraft carriers for the British Empire of 135,000 tons, United States 135,000 tons, Japan 81,000 tons, France 60,000 tons, Italy 60,000 tons. Moreover, no aircraft carrier may exceed 27,000 tons displacement. The gun-power of an aircraft carrier is limited, though the number of anti-aircraft guns is unlimited. Our aircraft carriers have a capacity of twenty-five planes for 10,000 tons of displacement, or two and a half per 1000 tons. Probably, in future ships, the ratio will rise to three planes per 1000 tons of displacement, if not more. Even at that percentage, the tonnage allowed us by the Agreement could produce 405 airplanes on properly equipped carriers at any given moment at any desired spot in the Seven Seas.

The aircraft carrier is provided with facilities for both launching and landing. The former requirement is met by catapults and other devices, the latter by shock and momentum absorbers, such as nets, springs, or rubber ropes on a specially prepared deck. Such aircraft could probably be launched into the air at the rate of about one every five minutes from each ship. From nine carriers, each of 15,000 tons, making up the total displacement at present authorized for the United States, nine airplanes could take wing every five minutes, or, say, one hundred an hour for four hours. In addition to the authorized aircraft carriers, an attacking sea base would no doubt include an establishment of spare planes on special store tender ships, so as to be in a position to make up for wastage. There is no limit to the number of these tenders which can carry planes of all sorts.

So far we have only visualized a law-abiding foe who feels himself bound by the international instrument above-mentioned. But he will not necessarily allow himself to be fettered at the outset by a written covenant merely because he has solemnly signed on his honor to abide by it. He can quote a precedent. He will realize that he must meet a brave and efficient association of nations and will naturally wait till he has perfected in secret all the requirements that a scientifically trained staff can foresee. For instance, large ocean-going submarine seaplane carriers are no more fantastic than the prophetic *Nautilus* and *Clipper of the Clouds* described by Jules Verne so many years before their time.

In the past, successful surprise raids were more easily carried out from the sea than from the land, because preparation could be concealed and traces destroyed: how much more so will they be possible by air?

Previous to 1914 a great attack on the United Kingdom must have been preceded by superiority at sea, temporary and local though it might be; even Napoleon conceded this point. Under present conditions, as the radius of efficiency of aircraft increases, great superiority in the air will be advantage enough, and it will be much cheaper to obtain. In the day of hostile superiority in the air and in the face of constant attack from ever-changing bases, the concentration of the Grand Fleet at Scapa Flow for such a length of time would be impossible, and even land mobilization would be greatly disorganized.

This threat of a smothering offensive from the clouds is so imperative and conclusive as to warrant the greatest efforts for the provision of men, money, and material to insure an adequate defense against it by the time it reaches its danger point. Our counter-effort must be built upon efficient information and a rightly-conceived defensive power. By the nature of things the invention of the offensive weapon must needs precede the design of the countervailing system of defense. The sword preceded the shield. An adequate defense to counter any process of attack will always be produced eventually. The sole question for the defense is, to speed up the new invention so that the period during which that special engine of attack can reign supreme may be reduced to a minimum.

The defense against aerial attack at present consists of aircraft, searchlights, guns on special mountings, and sound locators, not forgetting electrical communications and camouflage. There are several other possibilities in the future which will be developed in due course as surely as was the shield and the A. A. gun. At present electrical communications and sound locators must supply the requisite information and the guns, searchlights, and aircraft the efficient defense. Sound locators will doubtless become more sensitive and accurate and their intimate connection with the searching beam will become automatic and assured, while gunfire will be more accurate and intense.

But one of the great lessons which the warfare of the past should have taught us regarding warfare of the future, embraces the fact that if the defense at the outset of hostilities does not hold up the attack, the attack will overwhelm the defense: there is no possibility of stalemate in the air. As a nation we seem to have been consistently unprepared for our wars. The sea has been our first defense, and, with our "standing luck" or our national character, it has always enabled us to make up for unpreparedness, so far; but——?

If there should be such an attack on the Empire, where will the blow fall? An overwhelming attempt on either Canada, Australia, or any other outlying member of the family, would certainly have but the effect of sending such a thrill through the others as would solely result in cementing them more firmly together and bracing up their spirits to fight it out to the last man and the last shilling. To obtain the best strategic result, the blow should fall not only on these islands, but on the southern portions of Great Britain, the center of the web. Naturally, therefore, the major part of the defenses of the Empire must be based upon Great Britain. The principal nerve centers to be defended from aerial attack are the large harbors and anchorages, barracks, ammunition depots, the factories of warlike stores, and the great cities and towns of England where Bolshevik upheaval might be hoped for by the enemy.

Aerial attacks on inland objectives will generally be carried out in formation by night. Formation flying is imperative in order that the units may not foul each other, especially in a large concentration, and that they may be able to keep up the necessary rain of bombs on the required target. The approach of a formation by night is always made along some route which may be easily picked up in the dark, and which will present some definite and recognizable landmarks, such as the edge of seashores or lakes, a river, railway line, or main road.

Though the best defense against aircraft is furnished by aircraft, the other defensive elements on the ground have much the same effect as field fortifications in a land war of movement. In addition to the actual losses they cause, they render it possible to concentrate the main force at the point where it can produce the most telling result. As barbed wire provides the quickest and most effective means of denying ground to a land enemy, so aerial impediments have afforded the most effective way, so far, of denying certain avenues of approach by night to hostile air-raiders. They have one great advantage over barbed wire. They are not immovably fixed to their site, but can be moved about as required so that they combine the element of surprise which is so harrassing to the airman's nerves. Other means are also in course of production. In this manner the most probable lines of approach to a target such as has been enumerated can be made extremely difficult by raising across it some such obstruction. For if a flying formation is once broken up at night, it loses at once its greatest asset for successful service, if not its actual existence.

In the past an attacking navy had the power of suddenly concentrating a superiority of gunfire against its objective and for this reason coast fortifications had to be scattered so as to be ready to take up the challenge instantly wherever it might be flung, and to hold the line

till reserves could be brought up to neutralize the superiority due to surprise. In the future the attacking air force will have similar power, and therefore, for a like reason, antiaircraft defenses must be dispersed and in position round the key-points, as the period of warning will be shorter than ever. Successful raids would otherwise be the rule and not the exception.

But a strong enough antiaircraft defense would confound the tactics of the enemy by leaving the active air squadrons free to defeat him strategically. Even if the defender's air force is strong, compared to that of the opponent, an adequate antiaircraft defense will insure economy of force and enable the defender's active air units to be used to the best advantage irrespective of the attack. But when the defender's air force is weak, a supreme antiaircraft defense is an imperative necessity as an insurance against annihilation.

In the period before the last war, our degree of necessary preparedness was assumed to be less than that of a great continental power because of our insular position and the value of sea power. Now the difference, as far as aerial warfare is concerned, is entirely eliminated and we stand exactly the same danger from an overwhelming lightning stroke as did our allies of 1914. We should, therefore, see that the training and equipment of our antiaircraft measures shall be the most efficient in the world, so that, if called upon in the future, our defense may prove itself as potent as before. To set the foundation stone to this, it is necessary to plan in detail our antiaircraft policy and the positions of all its component parts. But it is only by completion of at least one entire section of the defenses in every detail that the test for the ultimate limit of efficiency can be applied to it, so as to find the weakness and enable experts to work out the remedy.

Whenever a new means of warfare has been produced, a certain period of time must necessarily elapse before the best means of cooperation with the other arms can be worked out to a satisfactory conclusion. How will it affect strategy or tactics? What modifications will it necessitate for other branches or services? What changes of establishment will it induce?

These vital questions can only be answered by selecting a certain important area for experimental purposes and then by working out the application and technique of the means now coming to fruition. First, the application of the ever-true principles of strategy in making the estimate, *i. e.*, the objective, the difficulties to be overcome, the resources at our disposal, and the plan, and when that has been completed on the ground, the application of the breaking test.

Characteristics of 8-inch Guns and 12-inch Mortars, Railway Mounts*

By CAPTAIN GEORGE W. RICKER
Coast Artillery Corps

GENERAL DESCRIPTION

THESE two types of railway armament are discussed primarily because they are of such importance in our scheme of defense. There are two good reasons for this statement. In the first place, we have more of them than we have of any other kind. In the second place, they may be rapidly emplaced, they are accurate and dependable, capable of reasonably rapid rates of fire, and have all around fire, all of which factors combine to make them particularly well adapted to fire at moving targets. All other types of railway guns (except about a dozen 7-inch navy guns which are on mounts similar to the 8-inch) have to be mounted on concrete gun blocks before they can be fired at moving targets. Guns of this type are the 14-inch, Model 1919; 14-inch, Model 1920; and the 12-inch, Model 1918 (Batignolles) modified.

Both are of the type known as the "platform mount." The gun consists of an 8-inch gun, Model 1888, 32 calibers long, mounted on the 8-inch barbette carriage, Model 1918. The carriage is mounted on a steel base ring bolted to the drop section of the car, railway car, Model 1918 MI. The carriage traverses through 360° in the usual way by means of rollers and racer. The firing platform is of simple form. H-beams are placed just outside the standard gauge rails and parallel to them. The car is then moved by hand over the H-beams and jacked up by means of four built-in screw jacks. Six wooden beams are slipped underneath the car body and across the H-beams. The car is then lowered so that the whole weight of the mount rests on the platform composed of the six wooden cross beams, the H-beams, and the crossties of the road-bed. The trucks are not removed but are relieved of all weight. The platform takes the vertical component of the firing load. The horizontal component is taken up by eight outriggers, four on a side. The thrust on the outriggers is transmitted to wooden floats embedded in the ground. The recoil mechanism is the well known hydraulic brake with spring return. There is a single recoil

* Lecture at Unit Camp, 601st C. A. (Ry.), Fort Andrews, Mass.

Data Sheet for
 8" Gun-Model 1888 on 8" Barbette Carriage-Model 1908

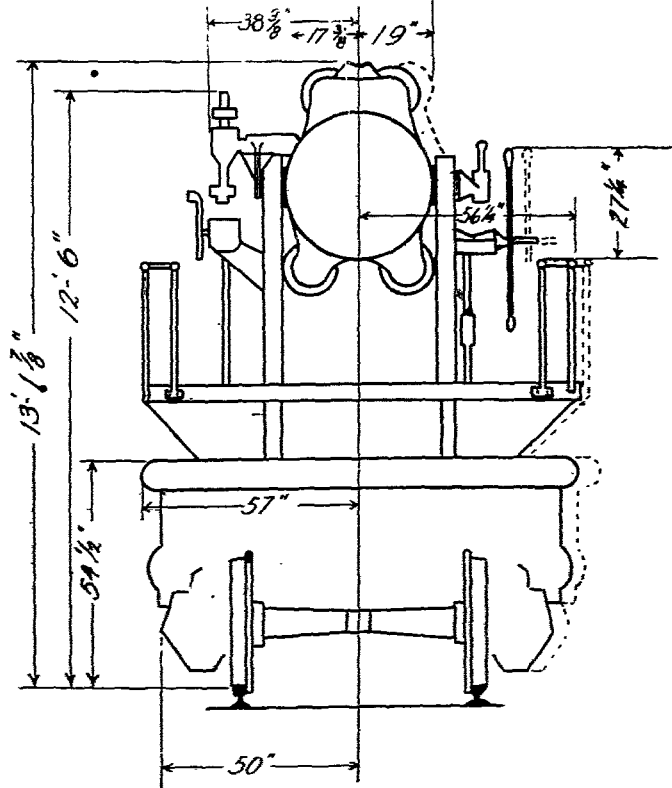
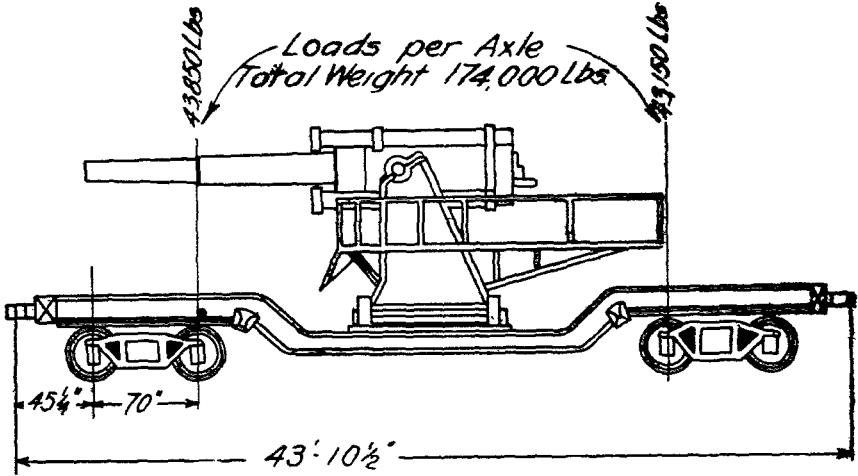

Dotted Lines show overhang allowance necessary for Car. on a 15° curve (Radius 383 ft)

cylinder filled with hydrolene oil, and four counter-recoil spring cylinders. To the recoil band, which is shrunk on the breech of the gun, are bolted the piston rod and the four spring piston rods. When the piece is fired the gun recoils in the cradle; the piston rods and pistons move rearward with the gun, while the cylinders remain stationary with the cradle. The recoil cylinder, by means of its buffer, also controls the motion of the gun as it is returned to battery by the reaction of the counter recoil springs against the compression set up by the force of recoil.

The 8-inch gun fires two projectiles, the 200-pound, HE, point-fused common steel shell, and the 323-pound armor-piercing shot. For the 200-pound shell two powder charges may be used,—the full charge with a muzzle velocity of 2600 foot-seconds, and the three-quarters charge with a muzzle velocity of 1950 foot-seconds.

The 12-inch mortar, Model 1890, is mounted on the mortar carriage, Model 1918, on the railway gun car, Model 1918 MII. The car is exactly like the 8-inch gun car except for a stronger construction of the drop section made possible by the difference in recoil between gun and mortar, and for the fact that it has 6-wheeled instead of 4-wheeled trucks. The mortar and a sleigh which is shrunk to it recoil in a cradle of massive construction. Recoil is controlled by two hydraulic cylinders filled with a half-and-half mixture of water and glycerine. The counter-recoil system or recuperator is of the hydro-pneumatic type. It consists of a compressed air chamber, a floating piston, and a plunger filled with water and glycerine, half-and-half. The air in the chamber is under a pressure of 1370 pounds per square inch, and the liquid is kept under a pressure of 1500 pounds. When the mortar recoils the recuperator piston further compresses the air in the chamber, so that when the force of recoil is spent, the expanding air pushes the piston forward and returns the mortar to battery. The purpose of the liquid in the plunger is to provide an airtight seal. The mortar fires in ten zones, using two projectiles, the 700-pound in zones VIII to X and the 1046-pound for zone VII and under.

Both mounts are laid in elevation by means of a quadrant graduated in degrees and minutes, which is fixed to the right trunnion. For pointing in direction, Case III is always used and two methods are possible—first, the use of the panoramic sight with an aiming point or aiming rule; and second, the use of the base-ring azimuth circle. On the guns this azimuth circle is adjustable but on the mortars the scale is fixed, so that a correction is necessary for the direction of the track unless it happens to be zero azimuth. The use of the sight is by far the best method as it eliminates entirely any errors in direction due to the base ring being out of level. The sight bracket is so mounted by a system

Data Sheet for
 12" Mortar - Model 1890 MT on 12" Mortar Railway Carriage Model 1918

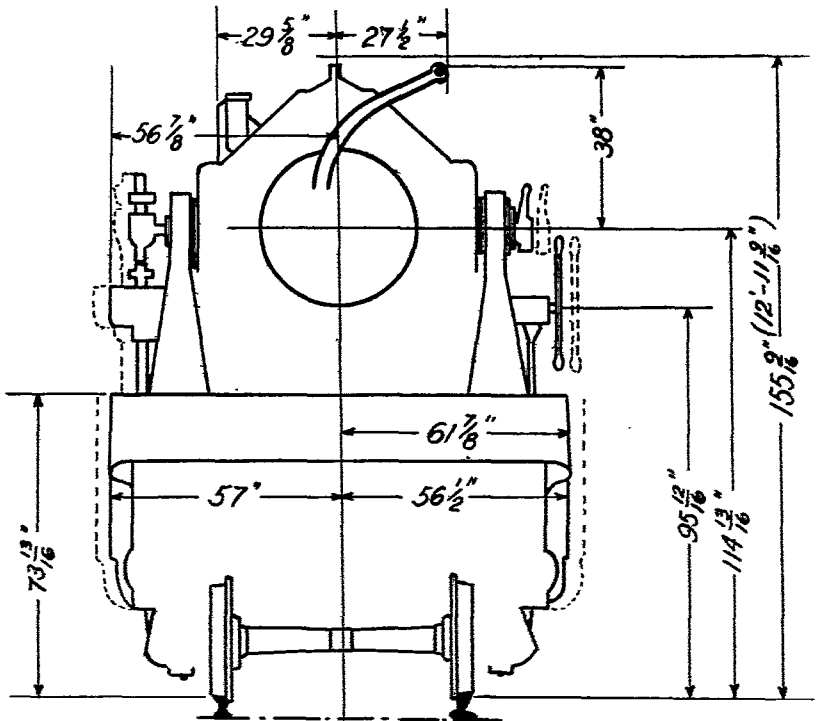
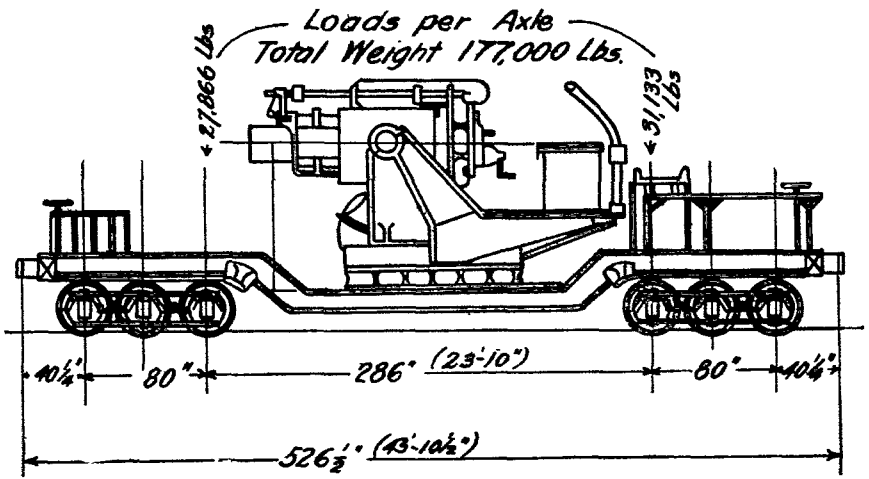

Dotted Lines show overhang allowance necessary for Car on a 15° curve (Radius 383 ft)

of linkages that the vertical axis of the sight remains always parallel to the vertical plane through the axis of the bore, so if the base ring is not level, as the piece is elevated the line of sight will be thrown off the aiming point and the act of bringing the line of sight back traverses the piece by the amount necessary to correct for the error introduced by lack of level.

METHOD OF EMPLACING AND WITHDRAWING

The method of emplacing has already been indicated in describing the car. Important points to remember in this connection are:

a. The roadbed for the emplacement must be level both ways, and the ties must be sound and firmly ballasted. Failure to carry out this requirement may cause the mount to have an uneven bearing on the platform and may lead to great difficulty in traversing.

b. Do not try to emplace on a fill. The false work is not easily made stable enough to remain firm under the shock of firing, and the average railroad fill is not wide enough on the shoulders to provide sufficient backing for the side outrigger floats.

c. Avoid ledgy ground. It is impossible to dig float in ledges.

d. Be sure that the floats are set in planes perpendicular to their respective outriggers, and that the outriggers are originally set to allow enough adjustment to care for subsequent settling or packing of the float backing.

e. In firing at fixed targets it is usually necessary to emplace only the outriggers lying in or near the line of fire. In firing at moving targets it is best to emplace them all.

f. Be sure that the mount is headed the right way before it is emplaced. If a firing spur has to be constructed, it should, if possible, be made to point in the general direction of the field of fire. The ammunition car should be placed on the spur behind the gun so that it can be switched out for replenishment, and the gun car should be headed so that its rear end will be next the ammunition car.

In various pamphlets and data sheets appears the information that the time necessary to emplace these mounts is one-half hour. The man who wrote that was an optimist. I once saw it done in an hour and forty minutes by a well-trained gun crew working under the most favorable conditions, and I have seen it take all day. The average time is about two hours. Much time may be saved by having the work well organized, keeping the entire gun crew busy, and performing as many of the various tasks concurrently as possible. The order of performance of work is given in *Gunners' Instruction, Railway Artillery, 1925*.

Withdrawal is simply a reversal of the operation of emplacement. It takes about one hour when a'l equipment is stowed for transit.

AMMUNITION CARS AND METHODS OF HANDLING AMMUNITION

Standard steel ammunition cars of types suitable to each caliber are provided as part of the battery equipment. (See Organization Tables.) These cars are equipped with suitable racks for the secure stowing of projectiles and powder containers, and with differential chain hoists and overhead trolleys for handling projectiles. The 8-inch ammunition car contains 96 complete rounds and the mortar ammunition car 48 rounds. The 12-inch mortar car itself (the gun car) is equipped with a small truck to which the projectile is lowered from the end door of the ammunition car. This truck is pushed forward to the rear end of the carriage by hand, and the projectile is either placed on the shell storage trough on the car which holds three projectiles, or hoisted to the loading stand on the carriage platform, which also holds three projectiles. From the loading stand it is rammed into the mortar.

With the 8-inch gun the projectiles may be served from the car, or, if the line of fire is about normal to the track, from the ground.

It is not considered good practice to leave powder charges, primers, or fuzes in the ammunition car after arrival in the firing position. Powder charges should be stored in small detached groups located about the position. Each group should consist of from five to ten charges and should be provided with ample cover to afford protection from shell fragments and from the weather. Primers and fuzes should be stored separately in small lots in well-protected places about the position.

TACTICAL CHARACTERISTICS

"Tactics" has been defined as the art or science of maneuvering military forces in battle. The "tactical" characteristics of artillery weapons, then, may be considered to be those which govern or materially affect their use in battle. The more important of these characteristics are: (a) mobility, (b) dependability, (c) vulnerability, (d) accuracy, (e) rapidity of fire, (f) range and field of fire, (g) fire power.

a. Mobility. We hear a great deal about "strategic" mobility and "tactical" mobility, and of railway artillery we are told that, in general, its strategic mobility is high and its tactical mobility is low. That simply means that railway guns may be placed anywhere you want them (where there are railways of course) in anticipation of an expected battle, but that you have very little chance to move them about to meet changing situations after the battle has once begun. Next to the sliding and rolling mounts which fire from epis and can be moved in or out of position in a few minutes, the 8-inch and 12-inch mortars have the greatest tactical mobility of any of our mounts. As I have said, the average time to emplace is about two hours; to withdraw from

position and load and stow equipment for travelling takes an hour; to withdraw leaving H-beams and floats in position takes only thirty to forty minutes, and to re-occupy a position with H-beams and floats already down takes about an hour. Thus it will be seen that a battery in an exposed position could, without much trouble or delay, withdraw its guns to safety upon completion of a given firing program, and re-empplace them for further action upon comparatively short notice.

b. Dependability. Neither the gun nor the mortar have any fragile or complicated mechanisms easily disarranged or put out of action. They are of simple and rugged construction and with reasonably good care will function perfectly under the most adverse conditions.

c. Vulnerability. It would probably take a direct hit to destroy or damage seriously one of these mounts. As to vulnerability to discovery by enemy observers, either aerial or terrestrial, they share the characteristic of all railway artillery of being difficult to conceal.

d. Accuracy. In spite of opinions to the contrary, these weapons are just as accurate as the same weapons on fixed mounts. With a battery of mortars firing as a calibrated battery at a moving target, the developed armament probable error of the battery was 34 yards. (Battery D, 52d Artillery, May 16, 1922; average range, 9100 yards; 40 rounds.) Other practices by the same battery and other organizations gave similar results. The 8-inch gun has had developed armament probable errors from 70 to 100 yards in service target practices at moving targets at ranges from 13,000 to 15,000 yards. (Batteries E and F, 52d Artillery.) In 1920 at Provincetown, Mass., the 42d Artillery fired 8-inch guns at moving targets at extreme range, 22,000 yards, with excellent results.

e. Rapidity of Fire. On account of their construction and the methods of loading, the rates of fire are necessarily slower than those possible from similar weapons of the fixed defenses. A rate of one shot per gun per minute can be maintained by the guns and of one shot per gun per two minutes by the mortars. Battery F, 52d Artillery, fired 57 shots in 37 minutes using two 8-inch guns, and Battery C fired 35 shots in 36 minutes using two 12-inch mortars, both practices at moving targets. Thus it will be seen that war strength batteries (four pieces) of these types can deliver and maintain a heavy volume of fire.

f. Range and Field of Fire. The maximum ranges of these weapons are 21,150 yards for the 8-inch gun with the 200-pound projectile and 23,950 yards with the 323-pound; and 15,300 yards for the 12-inch mortar. For both the field of fire is 360°. The use of two powder charges with the 8-inch gun makes it possible to deliver plunging fire for a large portion of its range, and makes it, therefore, a weapon

against which it is difficult to secure defilade. The mortars of course, use high-angle fire at all ranges.

g. Fire Power. The three characteristics last mentioned, accuracy, rapidity of fire, and field of fire, combined with the destructive effect of the projectile used, determine the fire power of a weapon. While the old 323-pound AP projectile can be used in the 8-inch railway gun, the present policy is to manufacture for the secondary armament nothing but common steel shell. It has a highly destructive effect against land targets and sufficient penetrative power to pierce the plates of lightly armored and unarmored vessels which are the proper targets for these guns. Against naval targets the mortars fire two projectiles, both deck-piercing, the 700-pound and the 1046-pound. Against land targets a 700-pound common steel shell is used. The deck-piercing projectiles will penetrate any thickness of deck armor encountered, while the common steel projectile, has a tremendously destructive detonation. The average crater is from 25 to 35 feet in diameter and from 8 to 15 feet in depth, depending on the kind of soil and the fuze. A battery of four 8-inch guns can deliver four shots per minute, sustained fire, and a battery of mortars two shots per minute. In land warfare either type can change target and direction over the widest possible field of fire without delay, and in naval warfare a moving target may be held under fire until out of range.

The industry of the army and the general industries of the country cannot be completely separated when the needs in time of war and in the development of the general industry are taken into consideration. On the contrary, they are ever approaching nearer and nearer to each other as the civilization of the world advances.—*U. Kobayashi, in Military Industries of Japan.*

EDITORIALS

The Army a Training School

SINCE the time of Josephus Daniels as Secretary of the Navy, this Nation has recognized the Navy as a national training school. Every one understands that a warship—especially a battleship or a battle cruiser—is a vast and complicated machine and workshop. Its personnel must learn many things which will be of distinct advantage in civil life. A large percentage of the enlisted men receive instruction in the operation and care of steam engines, oil burners, turbines, motors, dynamos, storage batteries, and electrical apparatus of all kinds. Some must be cooks, hospital attendants, clerks, tailors, and barbers. Others are employed on airplanes and airships. Practically all learn something they can turn to advantage after they receive their discharges.

That the Army is an equally important factor in the education of American youth in civil pursuits has been less well known. When Secretary Davis recently laid this information before the country the newspapers commented upon it with considerable approval and some little surprise. According to the War Department figures, 44,179 enlisted men out of a total of 118,000 were, during a single recent month, employed in essentially non-military capacities. Of these, 4553 were engaged in the maintenance of telegraph, cable, and radio communication; 7800 were occupied in motor transportation; 9300 were clerks, typists, and accountants; 1200, including 73 X-ray photographers, were connected with the medical department; 4500 were employed in the care of animals; 940 were blacksmiths; 200 were working as printers; and 101 were railroad operatives. Troop and vocational schools accounted for more than 5000, while 429 were receiving instruction at public night schools in cities near Army posts.

These figures will disabuse the public of any idea that military duty in peace time consists solely of drill, inspection, guard mount, and training exercises. They show clearly that the Army, as well as the Navy, is preparing the enlisted man to return to civil life with a practical knowledge and an experience that will be of great benefit both to the man and to the community. As never before, the Army has become a tremendous training school, engaged continually in advancing the mental, moral, and physical attainments of the young men who enlist in the service of their country.

Artillerymen

To an officer who has been in the Coast Artillery for something like fifteen years, we recently addressed the question: "Are you an Artilleryman?" He thought we were joking, so we asked further, "What is an Artilleryman?" We are still looking for a clear, concise reply.

We find in the dictionary: "ar-til' ler-y-man (-man), *n.*; *pl.* -MEN. A man who manages or serves a piece of artillery; one who belongs to a body of artillery." This definition seems scarcely adequate. Most of us, for a considerable part of our career, have nothing to do with "pieces" of artillery. At the same time membership in the artillery is, of itself, hardly a sufficient qualification to enable us to lay claim to being artillerymen. Is a lieutenant newly-commissioned in the artillery an artilleryman? Can a recruit be an artilleryman?

If we add to the qualification of membership the qualification of ability to handle artillery technically or tactically, according to our grade, we open up a large field for discussion. How much and what kind of artillery must we be able to handle? In these days we have fixed artillery and railway artillery and tractor artillery and trench mortar artillery and antiaircraft artillery; we have guns and howitzers and mortars ranging from .30-caliber guns to tremendous weapons sixteen inches in caliber; we have searchlight batteries and sound ranging companies and ammunition service and submarine mine service. Must we know all of these? If not, what part must we know to qualify as artillerymen? Suppose we go a bit further and inquire what part must we know to qualify as *good* artillerymen. It may be that there is no clear answer to these questions, but they certainly are worthy of a little thought and will bear repetition. "What is an artilleryman? Are you one?"

The Personal Budget

In recent years, education—schooling—has come to play a most important part in military life. From the day he enters the service until, years later, he retires to a well-earned leisure, an army officer is connected almost constantly in some capacity with military education. His life seems to be a constant round of teaching or being taught. And yet in one vital respect his education is sadly neglected. Nowhere does he receive instruction in how best to live within his monthly pay check.

When a young man accepts a commission in the Army, he finds many and varied demands made upon him, of which only a few have a counterpart in civil life. His scale of life is necessarily more elaborate than would be the case were he starting out as a civilian. His items of personal expenditures are unavoidably more expensive than the corres-

ponding items in civil life for the same salary. At best, then, he forms a habit of living entirely up to his income and of considering himself fortunate to be out of debt. Saving, if it enters his mind, is postponed to await a better opportunity—which, somehow, never comes.

A few—a very few—become exceptions to the rule and show that it is possible to save in the Army. They budget their expenses, spend a little less than they receive, and make their savings work for them. They realize that the day must come when, after having given the best part of their lives to the service of their country, they will be retired from active duty on a pay equivalent to scarcely more than half of that which they had been receiving. Two conditions face them. They must either reconcile themselves to the fact that, after being retired, they will have to live on a vastly different scale than before, or they must save enough during their active service to enable them to live in reasonable comfort after retirement.

Saving is not easy, and few find their attempts to save productive of results. What army officer, in visioning the future or in considering the host of bills arriving in the mail about the first of the month, has not asked himself—not once, but many times, "How can I make some extra money?" Apparent opportunities reach him in almost every mail from promoters and agents all over the country. These all, however, require the investment of capital, and range from oil and gold-mine stock through real estate to bonds. Some are sound investments, some are worthless, and some are a promising speculation. The trouble is not in picking the sound investment from the wild gamble; the trouble lies in providing the capital. The average army officer, even with his limited business experience, can determine the approximate probable value of a contemplated investment; but he normally has nothing to invest.

The answer, of course, lies in a personal budget. A brief experience will indicate the average monthly routine expenditures. A little computation will determine a fair allowance for other expenses. Certain habitual items can be curtailed; others can be omitted. The final figure indicates the amount to be saved. Or the problem may be approached by beginning with the desired saving and adjusting the other items to correspond.

In either case the budget dictates what may or may not be done. A party? What does the entertainment fund say? An automobile? What of the recreation fund? Perhaps the party can be postponed, or made smaller, or given on a less elaborate scale. Perhaps the automobile can wait another year. Conditions may require the budget to be exceeded, but it can not be exceeded blindly.

Adherence to a budget is never simple. It involves two important things—rigid self-denial and complete disregard of the social pace set

by the neighbors. Neither of these is pleasant, but "it is better to be safe than sorry." Our occasional saving neighbor demonstrates the practicability of a budget. The necessary domestic cooperation can usually be secured. Once started, the rest is easy. As savings begin to accumulate, the banker or broker will give sound advice on putting the money to work, and, habit growing with the passing of time, the budget will point out the road to comfort in the later years.

Warlike America

The ways of the pacifists are beyond all understanding. The *Fall River News* calls attention to one of the most peculiar of their vagaries:

"It is almost laughable to see the pacifists in the country so wildly at work to get the United States to be 'peaceful.' Since when has this country been anything else? What time did anybody ever see Americans wildly rushing into war? Since when have we kept up a terrific armament race, or engaged in the wild conscription and training of armies?"

"Yet ever and anon we see the pacifist ladies and gentlemen running to Congress, lobbying desperately, as though world peace were threatened by some pernicious activity of American militarists—whoever they may be.

"Now we have the spectacle of Miss Jane Adams and a member of other pacifists interviewing President Coolidge, and begging him to use his influence to get the world to disarm. Miss Adams is international president of the Women's League for Peace and Freedom, and she believes that the United States should instruct its delegates to the preparatory armament limitations conference at Geneva to work for abolition of conscription, and 'complete world disarmament.' As the United States has no conscription, and the tiniest standing army in the world today, and as it is evidently the only major power which is taking this Geneva disarmament conference seriously, one wonders just why Miss Adams and her associates do not concentrate their attentions upon some other country."—*Detroit Free Press*.

Champions of Defense

Unhesitatingly branding modern war as horrible, wasteful and criminal, Maj. Gen. Hanson E. Ely, commanding officer of the United States War College, recently told Milwaukee Legionnaires that to champion the theory of avoiding war at any cost "is to teach decadence."

The statement is hackneyed, but none the less true, that the professional soldier is the one man who has the greatest reason to desire a condition of peace among nations. So long as peace endures he is

exposed to no especial hazards. The instant war is declared he is the first citizen called upon to adventure his life in battle.

All the more credit, therefore, is due such men as General Ely—who is representative of the Regular Army personnel—when he sternly refuses to countenance a pacifism that would place avoidance of conflict above all considerations of national honor and public safety.

Inevitably, the general is a champion of preparedness for emergency. He believes that if America had been prepared for war in 1916, it could have stopped the colossal conflict then raging without putting a division in the field. "One threat to throw our enormous resources and tremendous man-power against the warring side unwilling to treat for peace," he declared, "would have ended hostilities immediately."

It is well to study the conclusions of men such as he, who have devoted their lives to the profession of arms. They speak from knowledge. They are as averse to war as any civilian. Their conclusions are dictated by a patriotic desire to safeguard not only the nation, but also the lives of America's sons whenever forced to take the field in time of war.

Pacifism never has returned an answer to the grim question, backed by the experience of every struggle in which this republic ever has engaged: Why should the United States send untrained men into battle to be slaughtered needlessly because untrained in the art and science of war?—*Seattle Times*.

What Unpreparedness Cost the World

Developments in Europe, with the genesis of which we had no connection, led to our being forced into the war, primarily because we were so inadequately armed that the Germans judged our participation would not militate seriously against them. On the other hand, there was and is no question in informed American circles but what had we spent from five hundred millions to a billion in 1915 and 1916, primarily on our navy and secondarily on preparing to mobilize a great army, so that our weight obviously could be thrown quickly with determining force on either side of the contest, we could have ended the war on our own terms and without actually having become a belligerent. As Colonel House has put it in the Foreword to his recently published letters, " * * * I was sure, given a large and efficient army and navy, the United States would have become the arbiter of peace, and probably without the loss of a single life." Nor is it of any avail for apologists for Wilson's anti-preparedness to claim—as incompetent politicians habitually do—that the people would not have supported such a program of preparedness. For it is ever the duty and real test of political leaders to secure public support for the proper policy.

In short, the campaign for such armaments that we could have ended the war in Europe without going into it was defeated by undoubtedly well-meant but none the less misguided pacifistic abhorrence of all things martial—and by a total failure to understand that the most important function of armaments is to help secure predetermined ends without fighting. Is it not proper, therefore, to charge all of our needless waste of life and money in the European war and many of our consequent political and financial complications with Europe to the colossal mistake made by those who prevented our developing armaments appropriate to the obvious circumstances and contingencies soon after that war started? But until after Wilson's re-election in 1916, he told us the war was no concern of ours.—*Boston Transcript*.

Officers Forced Out

The very real character of the injury inflicted on the nation's military establishment by the neglect and excessive retrenchment of the last few years is indicated sharply in the report from Washington that since January 1 last, ninety-five army officers have handed in their resignations, the record for the same period last year being only forty-two resignations.

Officials of the War Department who are in a condition to know what they are talking about, say that the increase in resignations (which seems to be a progressive one from year to year) is due chiefly to two causes. Promotion has slowed down materially as a result of the reduction of the Army's strength since 1922, and married officers are leaving the service because of the wretched housing conditions at the posts.

The force of each of these reasons is easy to understand. The cutting down of enlisted personnel has been so drastic and destructive that it naturally drives ambitious youngsters with commissions into other fields. They see no future ahead in the service, and they can scarcely help feeling that devotion to the military establishment is lightly esteemed. They have no incentive of any sort to remain where they are.

The condition of a large part of the living accommodations for both officers and men is scandalously bad. The Secretary of War dealt with that matter at length and eloquently in his last annual report. He said tumble-down quarters were responsible for the prevalence of desertions among the enlisted personnel and were bad for morale generally. And it really is quite impossible to blame an officer for resigning rather than permit his wife and children to live indefinitely in some firetrap that is a constant menace to life.

The situation indicated may please scuttlers and professional pacifists, but it will hardly please any real American. It is a national

disgrace; and more than this, it is a national danger. Once thoroughly demoralized and thoroughly discredited as a medium in which to carve out an honorable life career, the military establishment will be a difficult thing to rehabilitate.—*Detroit Free Press*.

“Compulsion” in Colleges

A majority of the Northern Baptist Convention has voted against compulsory military training in schools and colleges on the ground the convention is opposed to war “as a method for the settlement of international disputes.” The clear implication of this move is that these church members believe there is a direct connection between military training and war, that the former would tend to encourage or uphold the latter. That being the case, one naturally is surprised that the convention confined its objection to compulsory training. Why not oppose all military training, especially the purely voluntary form of it? For if any type of the training encourages the war spirit it would be the voluntary kind.

But it is ridiculous to hold that military training tends to bring on war. One might argue with equal reason that training a youth to fight fire would make him an incendiary; or that training a man for police duty would make him a bandit or a supporter of banditry. This kind of objection, whatever the others that might be made, certainly is the weakest that could be brought against military training.

There are Americans who feel it is just as necessary that a boy be prepared to help defend his country in time of need as to know how to write good English.—*Kansas City Times*.

For “War Purposes”

Frequently the complaint is made that the United States is spending too large a percentage of total expenditures for “war purposes” or national defense. Those who favor a reduction of the Army and Navy to the level of a police force or a flotilla cite the enormous expenses for war between 1917 and 1919 and the apparent failure to reduce expenses for “war purposes.”

In 1810 the total expenditures of the National Government were \$8,474,753, of which \$3,949,314, or about 46 per cent went for the Army and Navy.

In 1860 the total expenditures of the government were \$63,200,876, of which \$27,986,853 or 44 per cent went for the support of the Army and Navy.

In 1916 the total expenditures of the government were \$724,492,999, of which \$319,665,003, or 44 per cent went for the support of the Army and Navy.

In 1924 the total Federal expenditures were \$3,506,667,715, of which \$665,594,533, or about 19 per cent went for the Army and Navy, or for "war purposes."

This indicates that the United States is spending less for national defense, in proportion to the total expenditures, than in former years.—*Washington Post*.

Moros on the Warpath

The killing of fifty Moros by the Philippine Constabulary at Lake Lanao in the Island of Mindanao will be regretted by Americans who know the Moro people. Most of those killed were so-called outlaws, who had entrenched themselves in small forts and dugouts locally termed "cotas." For a year or more they had been carrying on intermittent warfare against the Philippine Constabulary and had repeatedly refused the demands of the Provincial Governor that they surrender and dismantle their forts. For the peace of the countryside it was probably necessary that they be forcibly driven out. But with the motives underlying their resistance there is certain to be a good deal of sympathy.

The Lanao Moros, like their relatives in the Sulu Archipelago, submitted to the American forces only after several years of fighting during the first decade of this century. They have long been a warlike people, proud and passionately devoted to their own traditions and to Mohammedanism. The Americans disarmed them and won their confidence. At the same time, however, they gave them to understand that the Filipinos, for whom the Moros have always had a bitter scorn, would not be placed over them, and that Americans would look after their interests. The Moros accepted this at face value. But under the Harrison regime more and more Filipinos were introduced into the Island of Mindanao, and the Philippine Constabulary, patrolling the Moro country and which used to be largely officered by Americans, was almost completely Filipinized. When the Wood-Forbes mission visited Lake Lanao in 1921 its members were urgently besought to remove the Filipinos, and in particular to replace the Filipinized Constabulary with American soldiers. Shortly after this visit one of the leaders among the Moro chieftians, Ami Binaning by name, who had openly denounced independence and had urged that the Americans remain permanently in the islands, was murdered under circumstances that convinced the Moros that the Filipinos were wrecking vengeance on him for his

opposition to their politics. The Moros began to brood about this, and even though Governor General Wood put in an able American as Governor of the Province, the continued presence of the Filipinized Constabulary, which was the only available police force, preyed on the minds of the leaders. When a correspondent of the *Times* visited them last January they begged him to use his influence to have the Filipinized Constabulary replaced by white soldiers. They stated that the outlaws would willingly surrender to Americans, but not to Filipinos.

Hatred of the Moros for the Filipinos, when they have always looked down upon as inferiors, is at the basis of the present trouble at Lake Lanao. At the same time the older leaders among the Moros see that with the coming of schools and more people into their country their hold over the younger generation will gradually be broken. They are fighting to bring back the good old days when the Americans did not interfere with their customs except to prevent them from killing Filipinos. Today they see their customs breaking and their country policed by the hated Filipinos. What is worse, they see their friends, the Americans, apparently supporting the Filipinos. The Moros are thus the victims of too rapid Filipinization of the Government service of the Philippines. But they are fighting a hopeless battle and have been badly advised by those leaders who urged them to continue their resistance.—*New York Times*.

Wars are no longer fought by the armed forces alone. Every man, woman, and child, every resource and every dollar in the entire nation must throw its weight toward victory in time of war. Industry alone cannot win a war; but it can lose a war by failing to supply the armies with munitions, vital to their fighting efficiency.—*Assistant Secretary of War Dwight L. Davis, in Notes on Industrial Mobilization.*

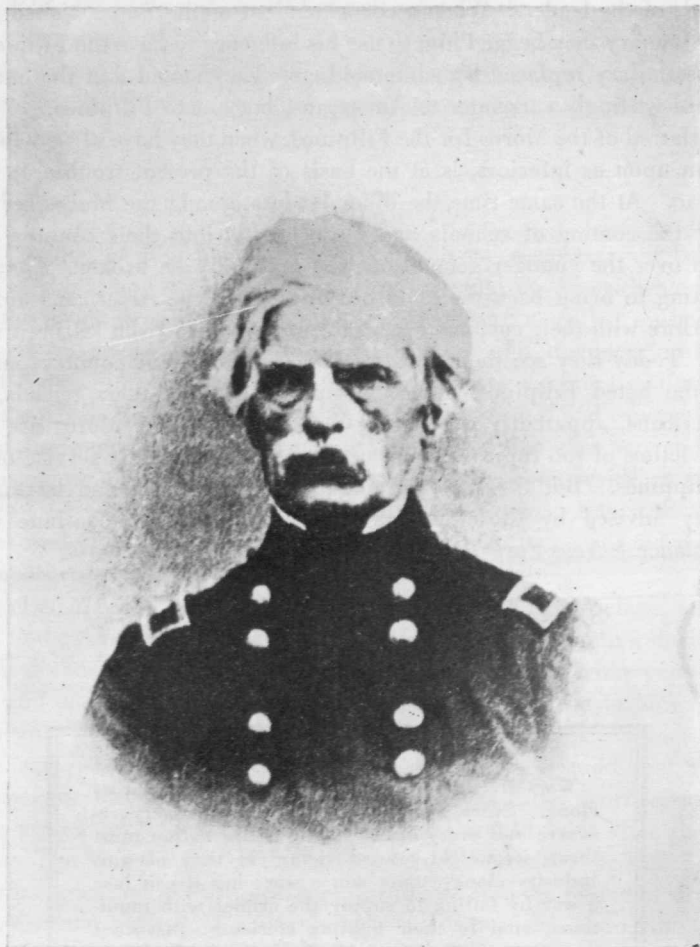

MAJOR AND BREVET COLONEL HARVEY BROWN
Commandant, Artillery School, 1858-1859

PROFESSIONAL NOTES

Correction of Data Errors of Averages Obtained from Small Samples

By W. A. SHEWHART

[Reprinted by permission from *The Bell System Technical Journal*]

EDITOR'S NOTE.—The *JOURNAL* for September, 1924, published an interesting and valuable paper entitled "Methods of Fire Adjustment," by Brigadier General R. E. Callan, U. S. Army. In paragraph 14 (p. 195) of this paper the "probable error of the probable error" for a series of n shots was evaluated. This evaluation was based on the classic or "customary" theory of error, which many mathematicians now believe should be reviewed. The accompanying paper, republished by courtesy of Walter A. Shewhart, A. B., A. M., Ph. D., and of *The Bell System Technical Journal*, which furnished the cuts, will serve to indicate the trend of modern thought on the subject.

SYNOPSIS: Recent contributions to the theory of statistics make possible the calculation of the error of the average of a small sample—something that cannot be done accurately with customary error theory. Obviously, these contributions are of very general importance, because experimental and engineering sciences alike rest upon averages which in a majority of cases are determined from small samples, and because an average cannot be used to advantage without its probable error being known.

The present paper attempts to show in a simple way why we cannot use customary error theory to calculate the error of the average of a small sample and to show what we should use instead. The points of interest are illustrated with actual data taken for this purpose. The paper closes with applications of the theory to four types of problems involving samples of small size for each of which numerous examples arise in practice. These types are:

1. Determination of error of average.
2. Determination of error of average difference.
3. Determination of most probable value of the root mean square deviation of the universe when only one sample of n pieces has been examined.
4. Determination of most probable value of the root mean square deviation of the universe when several samples of n pieces each have been examined.

USEFUL THEORY OVERLOOKED: WHY?

Practically everyone uses averages—research workers and engineers in particular. Moreover, all of us have long appreciated the fact that an average is often only of value when we know its probable error. Naturally, we turn to the theory of errors to guide us in calculating the probable error. Naturally, because from 1733 to 1908 there was nothing else that we could turn to. Since 1908 the recognition has been gradually making headway that to use customary error theory for determining the probable errors of averages of small samples is a mistake.

The story of how to calculate the probable error of a small sample was originally told in *Biometrika*, a journal for the statistical study of biology problems—a veritable mine of useful information. The truth was given in equations involving terms familiar only to statisticians and hence was concealed from many. The story, however, with the aid of such experimental results as are used in this paper can be told in a simple manner: it is of interest to all of us who, for one reason or another, cannot make large numbers of observations on every quantity that we measure, but must nevertheless estimate the probable errors of our results. In

this discussion, diagrams will be used instead of equations, and, because of this rather popular presentation, many readers may want to consult, as the original sources, the intensely interesting mathematical contributions of "Student,"¹ Professor Karl Pearson,² and R. A. Fisher.³

CASE WHERE CUSTOMARY THEORY APPLIES

We start, as in customary error theory, with the assumption that the probability distribution of errors is normal. This simply means that the probability of the occurrence of an error within any range is assumed to be equal to the area under the so-called normal curve⁴ (such a curve is shown in Fig. 1) between the limits of the same range. The total area under the curve is, of course, unity. This curve is plotted with the origin at the true value and with the errors measured

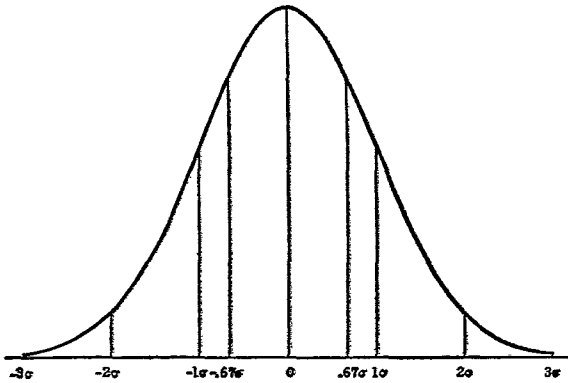

Fig. 1.—Customarily assumed law of error curve—normal law

50.00000% of area within $0 \pm .67449 \sigma$
 68.26894% of area within $0 \pm 1 \sigma$
 95.44998% of area within $0 \pm 2 \sigma$
 99.73002% of area within $0 \pm 3 \sigma$

in units of the root mean square error σ . The fractions of the area bounded by certain multiples of the root mean square error are shown for reference.

Let us make an experiment and see how far customary error theory carries us, see where it breaks down, see why it breaks down, and then avail ourselves of the new theory—a powerful tool of great value, because it makes possible for the first time the solution of many practical problems. Here is the experiment. Take 998 small circular chips, 499 green and 499 white. Mark 20 white ones with 0, 40 white ones with 0.1, 39 white ones with 0.2, etc., in accordance with the normal law. Do the same for the green chips except that all numbers on the chips are minus. Put the 998 chips in a bowl, mix thoroughly, draw out one and record it. Replace the chip, again mix thoroughly, and repeat the process until 4000 values are observed. A little reflection shows that this experiment is equivalent to making 4000 measurements of a quantity by a method subject to a normal law of error with a root mean square error of approximately unity.

¹ *Biometrika*, Vol. XV, 1908, pp. 1-15. Vol. XI, 1917, pp. 416-417.

² *Biometrika*, Vol. X, 1915, pp. 522-529.

³ *Biometrika*, Vol. X, 1915, pp. 507-521. *Proc. Camb. Phil. Soc.*, Vol. XXI, 1923, pp. 655-658.

⁴ The equation for this has recently been traced back to Abraham De Moivre (1733) by Professor Pearson. See *Biometrika*, Vol. XVI, 1924, pp. 402-404.

Let us group these 4000 values into 1000 groups of 4, and determine the average for each group, taking the first four observations as the first group, the second four as the second group and so on. This gives us 1000 averages. Suppose we subtract the true value m (in this case zero) from each average and divide this result by the root mean square error of the frequency distribution of values within the bowl. This gives us 1000 observations of the error of the average of 4 observations measured in terms of σ . Customary error theory shows that these

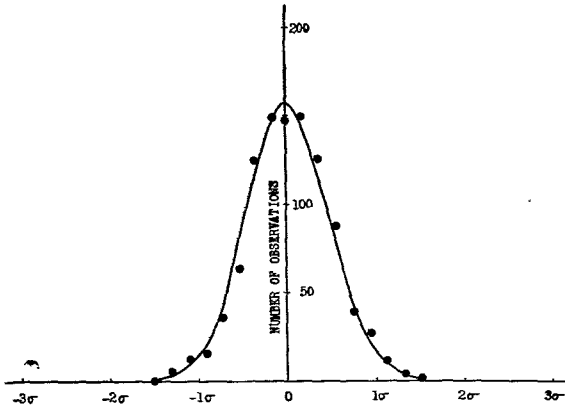

Fig. 2—Curve showing customary error theory to be satisfactory on one condition not often met in practice; *i. e.*, σ is known
 . Distribution of 1000 averages of 4
 - Normal law with root mean square error $\frac{\sigma}{\sqrt{4}}$

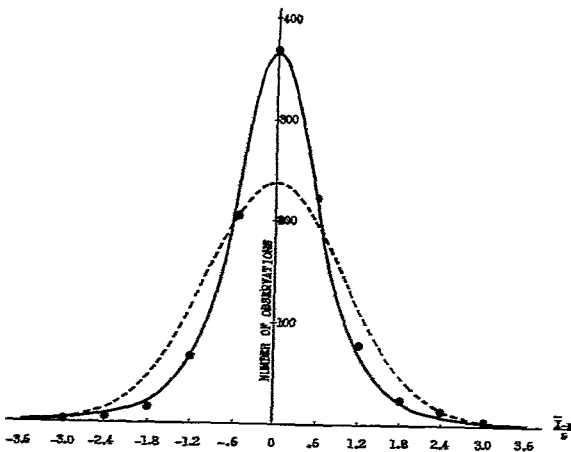

Fig. 3—Curves showing inaccuracy of customary error theory in finding error of average in terms of the observed standard deviation s
 - - - - - Customary theory
 ———— New theory
 . Distribution of 1000 z 's

averages should be distributed normally as indicated by the smooth curve in Fig. 2

with a root mean square error of $\frac{\sigma}{\sqrt{4}}$ or one half that in Fig. 1. The dots show the experimental results.⁵

So far the customary error theory is satisfactory. But we do not often have this case in practice; that is, we do not know the root mean square error σ , and instead know only the observed root mean square error s of the sample.⁶

CASE WHERE CUSTOMARY THEORY DOES NOT APPLY

Let us next recall just the way we use the customary theory in practice and then see what mistake we usually make. Take the results of drawing the first sample of 4 in the experiment previously cited. The four observed values are .6, -2, 1.1, -2.0, the average \bar{x} of these is -.125, and the observed root mean square deviation s is 1.177. Assuming no knowledge of the root mean square

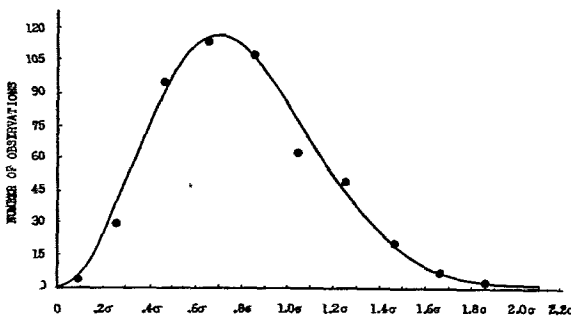

Fig 4—Data furnishing a clue to reason for inadequacy of customary error theory

- . Observed distribution of standard deviations of 1000 samples of four
- Theoretical curve of asymmetrical type

error σ of the distribution from which the sample of 4 was taken and using customary theory, we should assume the probable or 50% error to be $.6745 \frac{1.177}{\sqrt{4}}$. This follows from the fact that the observed values of the ratio $z = \frac{\bar{x} - m}{s}$ where m is the true value, are customarily assumed to be distributed normally. Here we come to the crux of the discussion: these observed values of the ratio are not distributed normally. "Student," in 1908, was the first to show how they are distributed.

Let us look at the observed frequency distribution of the 1000 z 's given by the above experiment (dots Fig. 3). To be normally distributed, as customarily assumed, these dots would have to lie on the dotted normal curve. Obviously they do not. Instead they lie on a much more peaked curve (solid line) than the normal. This was calculated with the aid of "Student's" theory. We must therefore conclude: the probability that the mean of a sample of n , drawn at random from a normal distribution, will not exceed (in the algebraic sense) the mean of that distribution by more than z times the root mean square deviation of the

⁵ I am indebted to Miss Victoria Mial and Miss Marion Caper for securing the experimental results, making all necessary calculations, and drawing the curves given in this paper.

⁶ Customarily we do not know the true value m , hence instead of knowing the root mean square errors we know the root mean square or standard deviations.

⁷ Loc. cit.

sample cannot be found from the normal law when n is small. We must use the tables provided by "Student" in the two papers referred to above.

WHY THE CUSTOMARY THEORY FAILS TO GIVE THE ERROR OF THE
AVERAGE IN CASE OF SMALL SAMPLES

Let us look a little further into the reason why the z 's are not distributed normally, before we consider the question as to the magnitude of the difference between the probable error determined from one theory and that determined from the other.

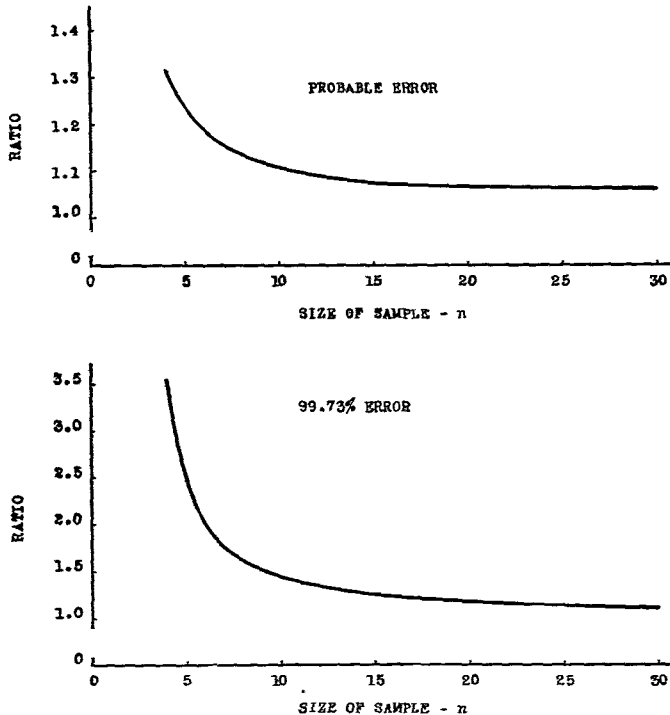

Fig. 5—Chart showing magnitude of correction for size of sample—ratio of the errors to their customarily accepted values

Let us look at the distribution of the 1000 standard deviations, the s 's, Fig. 4, for here we shall find the secret revealed: The distribution of s 's, as we might expect, is asymmetrical; the most probable standard deviation s , to be observed is not the average s . Of course, the customary theory assumes that the average s is the most probable s , and that the distribution of s , is normal. We should therefore expect to find the z 's distributed normally for values of n such that the distribution of observed standard deviations is approximately normal. Now, Professor Pearson⁸ has developed the theory underlying the distribution of s . He finds that as n increases, the distribution of s rapidly approaches normality. Even for n greater than 25 the distribution has approached normality to such an extent that

⁸ Loc. cit.

we should expect the z 's to be distributed approximately in normal fashion. The study of the distribution of z shows this to be true, as we shall see below.

In passing, we should note how closely the theoretical curve, Fig. 4, fits the observed points and also note two other checks between theory and observation furnished by the new data given herein. According to theory, the modal and mean values of s for samples of size 4 expressed in units of σ should be .707 and .798 respectively. The experimental results are .717 and .801.

HOW MUCH LARGER ARE THE PROBABLE AND 99.73% ERRORS OF AN AVERAGE THAN THE CUSTOMARILY ACCEPTED VALUES?

The difference between the error of an average and its customarily accepted value increases as the number of observations n (or size of sample) decreases. This fact is illustrated in Fig. 5. This figure shows the ratios of the errors to their customarily accepted values plotted for values of n from 4 to 30.

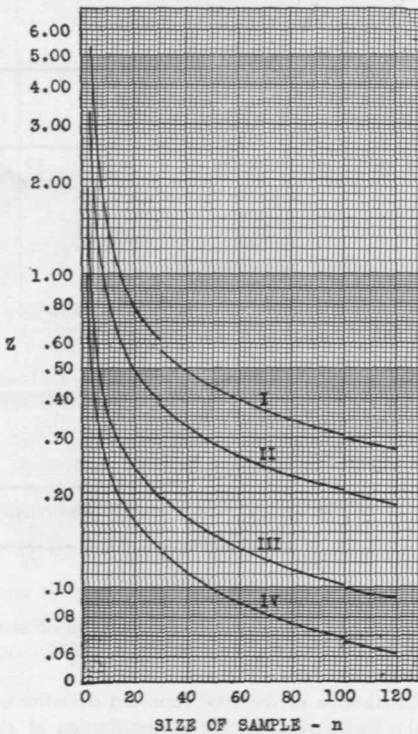

Fig. 6—Errors of averages of samples of size n

- I — 99.73002% error
- II — 95.44998% error
- III — 68.26894% error
- IV — 50.00000% error

z = the ratio of the error of the average to the observed standard deviation.

Curves showing the most frequently used errors of averages measured in terms of z (i. e., in terms of the ratio of the error to the observed standard deviation) are given in Fig. 6. The error curves for n less than 30 have been obtained

with the aid of "Student's" original tables, those for n between 30 and 100 have been obtained from the normal law integral tables using the standard deviation of z ; i. e., $\frac{s}{\sqrt{n}}$ as given by "Student." For n greater than 100, customary error theory has been used.⁹

TYPICAL PRACTICAL APPLICATIONS

But few, if any, recent developments of statistical theory are of more general application in most fields of scientific research and engineering than the one herein described.¹⁰ This follows because the theory herein discussed must be used in calculating the required probable error (or other measure of dispersion) of the averages obtained from small numbers of observations. The number of applications of this character is legion.

PROBLEM TYPE 1, DETERMINATION OF ERROR OF AVERAGE

Example 1:

Five samples of granular carbon taken from a crucible show resistances of 47.5, 49.4, 43.2, 48.0 and 46.2 ohms respectively. What are the probable and 99.73% errors of the average of these resistances?

Solution:

The observed values of average resistance \bar{x} , and standard deviation

$$s = \sqrt{\frac{\sum (\bar{x} - x)^2}{n}}$$

are 46.9 ohms and 2.097 ohms respectively. Hence from Fig. 6 we see that the probable and 99.73% errors are respectively $.372s = .780$ ohms and $3.33s = 6.99$ ohms, whereas from customary theory they would be $.302s = .633$ ohms and $1.34s = 2.81$ ohms respectively. The true probable and 99.73% errors are 23% and 148% higher respectively than those calculated by customary theory, as is evident from Fig. 5.

Discussion of Type 1:

Examples of this type of problem are obviously so numerous that further illustrations need not be given. They occur every day in practically every science. We see that in such cases it is certainly necessary to allow for the effect of the small size of sample.

* * * * *

PROBLEM TYPE 3, DETERMINATION OF MOST PROBABLE VALUE OF THE ROOT MEAN SQUARE DEVIATION OF THE UNIVERSE WHEN ONLY ONE SAMPLE OF n PIECES HAS BEEN EXAMINED

Example 1:

Five tool-made models are tested for their efficiency, giving values x_1, x_2, \dots, x_5 . What is the most probable value of the range within which the efficiencies of product instruments may be expected to lie approximately 99.7% of the time, assuming that a manufacturing process can be developed which is the same as that used in producing the tool-made models?

Solution:

Customary practice would answer: the average of the five values plus or minus 3 times their standard deviation. The better answer is: the average plus or minus

⁹ For the curves of this figure as in the preceding one. I have assumed the customary theory for the case where the true value of x is known so that the root mean square error of the average \bar{x} of sample of size n is the ratio $\frac{s}{\sqrt{n}}$. Of course, as we know from customary error theory, if we assume no knowledge of the true value of x , we should use $\frac{s}{\sqrt{n-1}}$

¹⁰ Since this paper was written, a very interesting article, "Statistics in Administration," has appeared in *Nature* (V. 117, pp. 37-38, Jan. 9, 1926), calling attention to the importance of the theory of small samples.

$\frac{3}{.7746}$ times the standard deviation.

This follows from Professor Pearson's work previously quoted. He has shown that the most probable observed standard deviation s of a sample of n from a normal distribution with standard deviation σ is $\check{s} = \sqrt{\frac{n-2}{n}} \sigma$. Substituting the value $n=5$ in this equation we get $\check{s} = .7746 \sigma$.

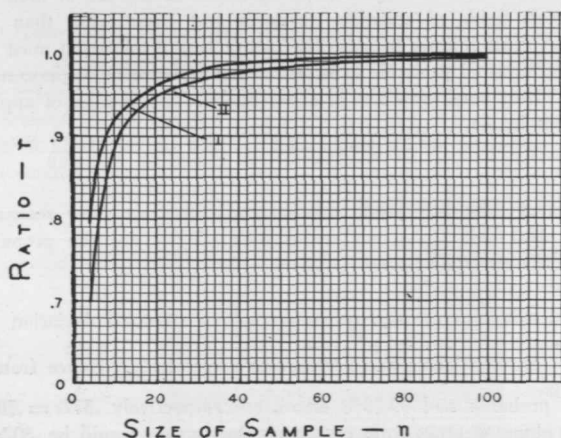

Fig. 7—Curves giving the most probable value of the true standard deviation σ
 I When the average \bar{s} of standard deviations of many samples is known. $r \sigma = \bar{s}$.
 II When the standard deviation of one sample is known. $r \sigma = \check{s}$.

A curve of the value of $\frac{\check{s}}{\sigma}$ vs. n is presented in Fig. 7 for reference in solving problems of this character.

* * * * *

Noncommissioned Officer Personnel

On page 78 of the COAST ARTILLERY JOURNAL for July is a table showing the present and prospective status of enlisted specialist personnel. Since this table was prepared the classes at the Coast Artillery School have been graduated and a more accurate forecast of vacancies and appointments is now possible. The following table should be substituted for the one given.

	Electricians	Radio Sergeants	Sergeants Major	Master Gunners
Graduates, C. A. School, 6/15/26	35	7	—	5
Appointed 6/21/26	25*	0	0	0
Vacancies or Surplus, 7/1/26	—5	0	+1	+2
Number on eligible list, 7/1/26	9	11	14	6
Estimated losses, fiscal year 1927	10	3	2	2
Remaining vacancies, 6/1/27	1	0	0	0
Remaining on eligible list, 6/1/27	0	8	13	6

* 1 graduate, Engineering Course, on eligible list for appointment as Radio Sergeant.

"You're in the Army Now"

By CAPTAIN A. C. M. AZOY, JR.

Coast Artillery Res.

So sang appropriately the bugles of the 62d Coast Artillery (A. A.), reveille on Monday, May 10, and thus the two weeks' training period of the 521st C. A. Reserve regiment opened with a bang at Fort Totten, N. Y.—the bang being supplied by the local morning gun.

Right here a word should be said for the versatility of the 521st. Not only is that gallant regiment in the Coast Artillery, but it can also qualify as a unit of the Camouflage Corps, for when the visiting reserve officers were lined up complete with credentials, it turned out that what was supposed to be the commissioned personnel of the 521st—on no less authority than that of the War Depart-



UNLOADING THE LISTENING DEVICE

ment—really showed only one-fourteenth of 521st content. There was a major, but he was from the 522d; there were two captains, one from the 522d, and one from the 212th Brigade Headquarters, while the first and second lieutenants hailed from the 530th and 513th, the day finally being saved from utter rout only by one lone shavetail with "521" above his crossed cannon. The roster ran as follows: Major F. W. Gilcrist, Captains John Ehinger and A. C. M. Azoj, Jr., First Lieutenants T. C. Sedgwick, J. P. Toler, Jr., W. K. Cooper, J. H. Haecker, and Second Lieutenants K. E. Baird, J. H. Kohlerman, W. G. Campbell, W. E. McKibben, J. D. Gayle, J. E. McHugh and H. E. Coston.

This did away with any chance of the officers functioning in the posts they would fill with their own outfit, so provisional assignments for ceremonies were made to the regular batteries on the post, and the reservists functioned as one cooperative unit in the theoretical and practical drills and exercises. The scheme worked admirably—in fact, it is doubtful if any other method of instruction could have done away with as much lost motion and at the same time bring home to the student officers such a comprehensive idea of what anti-aircraft is and why in so short a time.

Another fortunate circumstance was the fact that the training regiment was on garrison duty at a permanent post, and not in a camp that was permanent only so long as the wind didn't blow the tents down. Most of the reserve officers had tasted these latter conditions, but few had ever before experienced the regular life of the Regular Army. As a result, their enthusiasm is now strengthened by respectful affection for their professional brothers-in-arms. They are also prepared to defend with their lives the negative side of the popular subject, "Resolved: That Army officers lead lazy lives in peacetime."

Col. Spinks, commanding the 62d, and his brother officers had laid out a comprehensive schedule of training, and although no firing was indulged in, it was about the only item of antiaircraft artillery that wasn't. Searchlights, listening devices, machine guns, 3-inch guns, message centers, and convoys all received

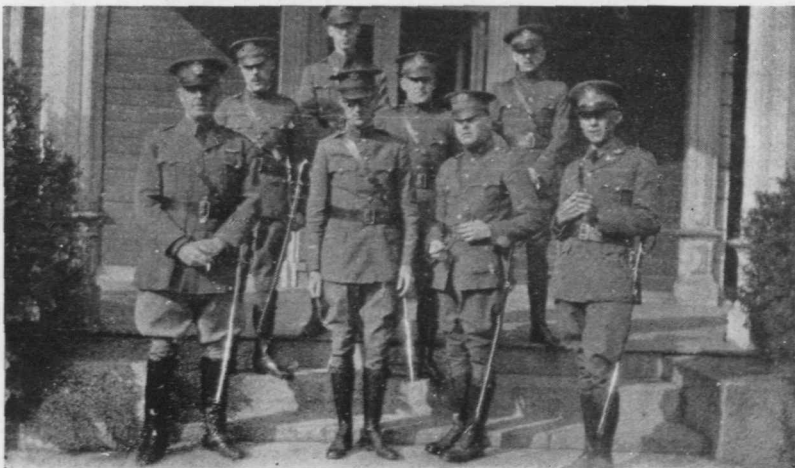

READY FOR REVIEW

their share of concentrated attention, supplemented whenever possible by actual work in the field. The new .50-caliber machine guns were inspected as well as the recently developed barrel type portable searchlights with distant control. Practice was also permitted with the searchlight plotting board invented by "A" Battery—a device so good that the Ordnance commandeered it from "A" Battery, adopted it officially, and then let "A" Battery have it back again on memorandum receipt!

The things that antiaircraft showed itself capable of doing and the things that aircraft were shown to be capable of doing were a revelation to those who believe all they read in the newspapers.

Much emphasis was laid on map problems, which proved a very popular part of the work. At first, sanguinary losses were suffered by heedless tactics of the Blues, but at last reports the Reds had been dislodged from Lancaster and were retreating completely off the grids.

Nor was the garrison part of duty lost sight of. Careful coaching allowed untried voices to shout commands without resultant speechlessness, and even the novices present quickly learned to handle a saber without any casualties to themselves or the adjacent real estate. Three reviews were given, one to General Howard S. Borden, the ranking general officer with the Coast Artillery Reserves.

In addition, formal guard-mounting was held daily with reserve officers taking regular tricks as adjutant.

There were also two baseball games between the regular and reserve officer teams. At least, that is what they were supposed to be, but opinion is divided as to whether they actually were games, and if so, if it was really baseball that was played. Such runs as were counted showed an overwhelming plurality for the regulars, though they did their best not to deserve them!

Added interest to the daily program was given by a motion picture company who borrowed one of the batteries to take part in a war film, several scenes of which were taken at the fort. These included night firing, and using the searchlights on a plane loaned by Mitchell Field. A camera was also placed in the plane,

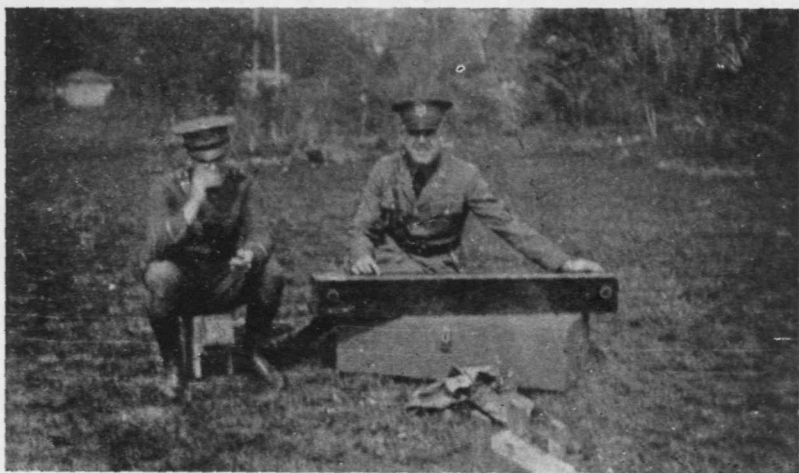

SEARCHLIGHT PLOTTING BOARD IN ACTION

and the resulting pictures show clearly how little chance an aviator has to find a target against these powerful beams.

As the last busload of what was still theoretically the 521st left the garrison, there were no dissenters to the opinion that a "good time was had by all." Perhaps sometime this very camp will be famous in song and story. At any rate, here is the story.

Address to the Graduating Class, U.S.M.A., 1926

By COLONEL HANFORD McNIDER

You who leave here today are better qualified for your life work than any men of your age from any school in America. You have been the recipients of the best the nation can offer. Your four years have been carefully planned for your future—and for the future of your country.

There is a splendid democracy in the way you were gathered together, in your curriculum, in your very life here, which has broken down all false standards among you. Yet you have been taught the discipline that makes men valuable in a self-governing republic.

There was a time perhaps when life in the regular establishment tended to hold men within a narrow compass, when duties and custom made the Army a

world within itself. That day and the army sufficient to it have passed. Today there is a broad demand upon men in your profession. You will be called upon to perform a diversity of tasks and missions in every phase of American life and in every part of the civilized world. You will serve with troops, with schools and in schools, as instructor and as student, in military studies and business affairs, in planning tactically, administratively and industrially the defense of our nation. Your range of contacts will exceed that of almost any other profession.

With those opportunities go inspiring responsibilities. You must qualify as the expert advisers of your generation in all matters of the national protection. You will eventually have a considerable responsibility in the building of character in the men who will serve under you, not only in the Regular Army but in the National Guard, colleges and schools, the R. O. T. C., and the C. M. T. C. The National Defense has broadened far beyond the old line of riflemen facing a visible foe. It now includes perforce every resource and every person in the nation—man, woman, and child. You will have in any great emergency the responsibility of hundreds of thousands of lives. That will fall upon every one of you because upon the tiny nucleus of the Regular Army must be erected the great framework of the national effort. The leadership, vision, decision, and ultimate success will to a large extent rest upon you and your fellows.

From personal experience, I have some idea what is about to happen to you. You are to report to some old outfit as its lowest ranking second lieutenant. Your new command will go out of its way to let you know that it has seen a hundred years of lieutenants arrive, that it has taught them to be soldiers with some difficulty and accepts you as just one more inevitable trouble to be borne with patience, forbearance, and a sigh. You will be expected to listen a great deal and offer little—and then only when asked. You will hear something about the last war, from the best historians it will ever have—the men who fought it. You will hear many fixed, set, and unalterable opinions about things military and otherwise. They will all be worth while, but don't dismiss your own entirely. You will serve under men and with men, particularly the old noncommissioned officers who know more about the Army than you'll know for many a long year. Absorb all you can from them, but leave room in your mind for your own discoveries. The world is always in a state of flux, and strange history is being written every day. Stay pliant, and remember that most battles—not military ones alone—have been won by common sense.

You need no reminder from me about what you are to represent to all America, or of what will be expected of you by tradition in the way of character, leadership, and duty. This great school has burnt those lessons into your soul. Let nothing erase them.

You are going out to troops. Your years as lieutenants are going to be the best of your lives, because your command will be direct. The platoon commander has the finest job in the Army. He knows every man he has. In peace or in battle he has the only real command of men. He knows the highest thrill and pride of leadership. With promotion will come further responsibilities, added duties to break down the personal contact that gives the profession of arms that something which appeals to us all. Therein are constituted the bonds which tie together all men who have served with the colors, never fully understood or appreciated by those who have not marched together under the flag.

You dream some day of commanding a battalion or a squadron, a regiment of a crack brigade—of seeing a great division march by you, ruffles sounding,

while you scowl down upon it from the biggest horse—to head such armies as West Pointers have before you. The General of the Armies, who has commanded more Americans under arms than any American in history, will tell you today that he would trade jobs and years with the last man among you, and go forth to command a platoon of American cavalry again the happiest boy in the world.

I congratulate you on the immediate duty before you. It is the finest experience you will ever have—your first command. Give it all you have. It will give back more to you. Make your platoon or section or whatever it may be the best unit of the Army. You can do it. No one but your men can help you. Your captain, your major, your colonel, will be interested, but not overly impressed perhaps. It will have to be you. Even when you are sure that your command has surpassed them all, keep at it. There will be two hundred other new commanding officers with similar ideas.

If the platoons are properly trained, inspired and led, anyone can command the regiments and divisions. The rest of the Army will take care of itself. If every platoon and every platoon commander know their jobs, we'll have what every man who has ever fought his way through West Point wants down in his heart—the best Army in the world. That's what you want to give us. That's what we expect you to give us. Good luck to you all in that endeavor.

Foreign Publications

REDUCTION OF ARMAMENTS FOR SWITZERLAND.—From an article in a number of the *Journal Militaire Suisse* by Colonel Ch. Sarasin of the Swiss Army, it appears that the disarmament microbe, fostered in Geneva, is beginning to make inroads in Switzerland itself and particularly in that section of the Swiss Federation adjacent to its Western neighbor from which it seems there has originated a suggestion that Switzerland should set an example to a much disturbed Europe by taking the initiative toward a reduction of military armaments. Colonel Sarasin takes stand against this movement in his writing of which a translation is here given:

The protocol of Geneva, having in view preliminary measures for a reduction of armaments of the powers has become cognizant of a movement of opinion in that direction in Switzerland, and more particularly in Western Switzerland, which, while it may embody an exalted idealism would, if it was further developed, have grave consequences for our country because it entails issues that cannot be ignored.

In an offhand manner we are told that Switzerland, a small neutral and peaceful power, ought to be among the first to give a good example by reducing or even wholly abolishing its army and its military budget. Against this movement, which has even made its way among our corps of officers, I desire to submit briefly the following for consideration:

The first form of disarmament and the only really efficient form is moral disarmament. Now in that way Switzerland has given an example for a long time. Our nation knows nothing about chauvinism; it has no desire to harbor either hatred, envy, or grudges against any other nation and it entertains no ambition that could be offensive or dangerous to anyone whomsoever. She also desires only one thing and that is to be left master of her proper destiny. It is that conception that has given rise to all dread of inter-mixture in international politics; it is from that that flows *Helvetic neutrality* so frequently badly understood and unjustly discredited.

If we will consider even in second line the question of armaments it is impossible not to admit that Switzerland is, of all countries of central Europe, the one which has long since been contented with a military system that is the most modest and most democratic, that of the armed militia.

While in other countries there have been kept and are still kept forces under the colors for some years, Switzerland gives its recruits instruction for sixty-five days and ninety days as a maximum in the year. We reject the standing army; we officers, with some rare exceptions, give the greater part of our time to civil pursuits which keep us in contact with all classes of our civil population. Militarism is, in its proper conception, an unknown quantity to us. We are therefore, well authorized to say to those who call on us to give an example of reduction of armaments: that example was given by Switzerland long ago. When it shall have been followed by others it will then be time to see whether we shall proceed further with it.

If, meanwhile, we examine or follow those who demand a reduction of the army or of the military budget, we arrive at two alternatives: either to reduce still further the duration of our service of instruction or diminish the effective by renouncing the principle of obligatory military service. I do not believe that any one can seriously think that soldiers can be made in less time than that of which we dispose. There remains then only the possibility of abolishing obligatory military service as an initiative for reduction of effectives.

I do not believe that the problem can be stated in any other form and it is imperative that those who urge Switzerland to a reduction of its army are cognizant of the fact that they attack directly one of the fundamental principles of our national life.

Our army, founded on the obligation of universal service is, in the eye of the foreigner, the affirmation of all Swiss people that we are opposed to all conflicts and are respectors of all rights, that we have determined to remain free and to defend our independence with all our power. For our interior army, such as it is, is democratic and national and is the great element of union and of order. That has been abundantly shown during all past years.

To take away from our army the principle that is the motive of its existence and cherished traditions, to disarm us in the midst of a profoundly troubled and disintegrated Europe, is thrusting our country blindly into the unknown: it is taking a serious responsibility of which I will hope that each one is aware.—G. R.

PROPOSED NEW ANTI-TANK WEAPONS.—Engineer Lieutenant Wm. Brandt, of the German Army, advances some new ideas on the subject of fighting and defense against tanks in an article published in the March 18, 1926, issue of the *Militär-Wochenblatt*. He says:

The best anti-tank weapon is admittedly the gun. It is, however, a moral necessity to provide the infantry itself with an anti-tank weapon but arms that can be carried by hand and are capable of piercing tank armor are heavy and unwieldy. The infantry rifle depends for success upon hits against sighting slits but such hits are made with difficulty: it would therefore appear to be expedient to use shot for that purpose. Since the eye of the gunner in the tank is back of the sighting slit a single shot grain going through the slit would disable him. With an automatic shot gun firing five or six rounds, several hundred shots could be sent against a slit in a few seconds. Detailed experiments with shot-firing weapons against tank sighting slits would certainly show some interesting results. If these experiments should give promise of good results every machine gun detachment should be furnished one or more shot firing weapons.

Another effective anti-tank weapon is the 2-cm. machine gun which is now usually drawn on sleds. The Netherland government has, with excellent success, put the heavy machine gun on a power motor-driven wheeled vehicle operated by one man. Why could not such a vehicle be adapted to carry the 2-cm. infantry gun whose projectiles are capable of piercing ordinary tank armor?

The special advantage of the two anti-tank weapons above mentioned would be their moral effect: they would relieve the infantry group from the feeling of helplessness and impotence to which a tank attack subjects them.—G. R.

THE POLISH FRONTIER GUARD CORPS.—A writer in the March 25, 1926, number of the *Militär-Wochenblatt*, referring to a publication recently issued by the War Ministry of Poland giving details of the organization, composition and activities of the Polish Frontier Guard Corps, gives extracts from the pamphlet in which he furnishes interesting information concerning this unique body of troops from which the following extracts are taken:

Conditions prevailing in the Eastern section of Poland adjacent to Soviet Russia have given much uneasiness to the government. There has been a growing feeling of insecurity in these regions which were annexed to Poland as an incident of the outcome of the Russo-Polish war of 1920-21 and are inhabited by a population largely non-Polish. Robbery, murder, surprise attacks, raids, were carried on by individuals and organized bands of armed outlaws. The low order of intelligence and the poverty of the greater portion of the population on both sides of the boundary line, made wild by war conditions on the one hand and by dissatisfaction with Polish governmental policies aggravated by skillfully planned hostile agitation by Russian communists on the other, all began to culminate in conditions of anarchy beyond the power of control of the local civil police. Small detachments of troops sent out occasionally were unable to restore enduring order and tranquility under conditions of a veritable guerilla warfare facilitated by the extensive forest regions and swamp lands of the Rokitno marsh sections.

To meet these conditions the government decided in August, 1924, to form a special Frontier Guard Corps which was organized by the War Ministry from personnel taken from the regular army. The Corps has its headquarters at Warsaw and is under the direct command of the corps commander who is also the permanent inspector of the mounted troops and is stationed at Warsaw. The organization has all the attributes and equipment of an independent army, including staff, operation and training divisions, independent information and intelligence detachments, supply, sanitary, engineer, pioneer and military justice details, etc. The corps is subdivided into brigades, the brigades into infantry battalions and cavalry squadrons. There are no regimental organizations. There are, at this time, five frontier guard brigades and twenty frontier guard squadrons stationed along the 1450 kilometers of Polish-Russian frontier, making an aggregate of 600 officers and 18,000 men. Its influence made itself felt as early as January, 1925, and it has now established a reasonable degree of safety and order on the entire frontier and especially in what were heretofore the most turbulent sections.

The functions of the troops are to assist the civil authorities in keeping order. All disorderly persons apprehended by the troops are turned over to the local civil peace administration authorities to be dealt with by them, the military taking no part in their prosecution and punishment after they have been apprehended.

From information contained in the pamphlet it is seen that the disorderly persons coming into the hands of the military frontier guard corps comprise: vagabonds forcibly deported or driven across the frontier by the Russian government authorities, professional smugglers, illicit and unlicensed traders, spies, Russian political "agents," political communistic agitators, couriers, informers and lookouts for bodies of bandits, deserters from the Soviet armies, etc. The personnel of the corps is specially selected from the army, the leaders being frequently changed.

The total number of delinquents apprehended from the establishment of the corps to the date of issue of the report referred to is seven thousand individuals of the classes above alluded to. Eighteen were killed and twenty-two wounded in pursuit or while resisting capture.—C. R.

Bat. "E" 60th Coast Artillery (A.A.)

Manila P.I., March 1926

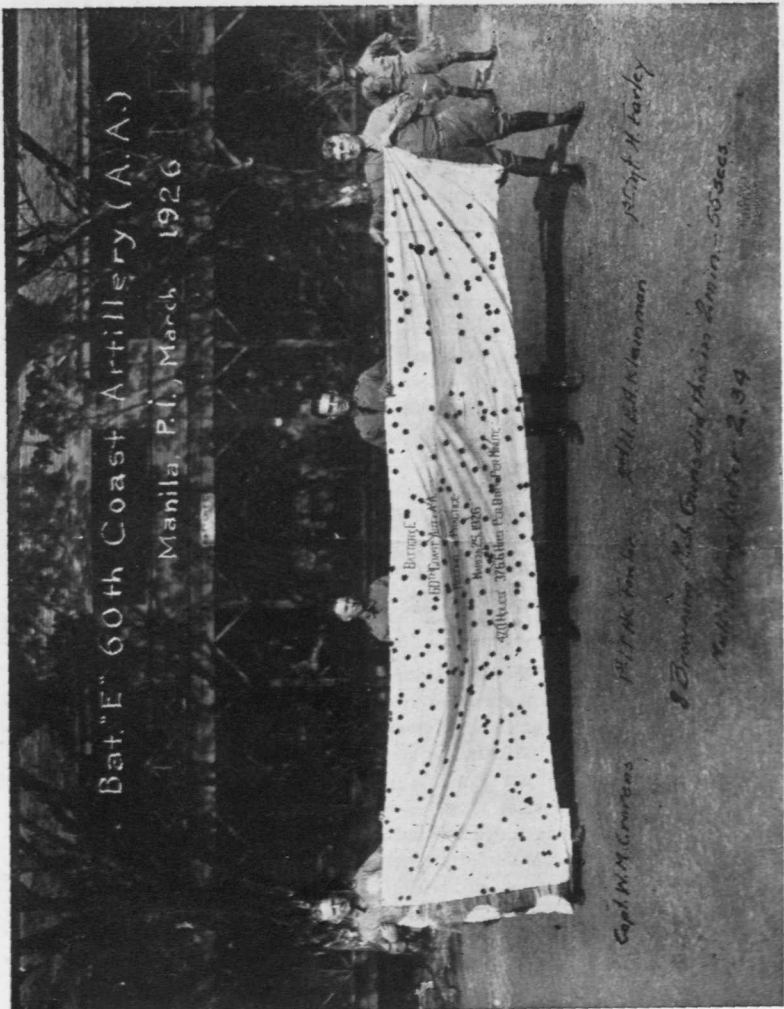

Capt. W. M. Courtes
1st Lt. H. H. ...
1st Lt. H. H. ...
1st Lt. H. H. ...
1st Lt. H. H. ...
1st Lt. H. H. ...
8th ...
Total ...

470 HOLES IN ONE TARGET

A Language Detail in Japan

LIEUTENANT THOMAS G. CRANFORD, JR.

[Extracts from a letter]

In reply to your letter concerning the Japanese language detail, I shall do my best to answer all your questions. I have been here nearly three years and believe that you can rely upon what I have to say, since it is all based on my own experiences and those of others. I mentioned your letter to the other officers on duty here and they agree with what I have to say.

First, let us speak of the detail itself—that is, the study of the language and the things that are incidental thereto. Your prime object here, as you know, is solely the study of Japanese. It is the opinion of many officers of the Army that this is an easy detail—that it is a grand and glorious four-year dead-beat. I assure you that it is not. The language is one of the most difficult of all languages; and very few, if any at all, have ever mastered it, and those only after a lifetime of serious effort. True, you do learn quite a bit during your four years here, but that is but the beginning. Very few foreign business men find it necessary to speak the language because so many Japanese speak English and other languages. One would find it difficult to capitalize one's knowledge of Japanese, even if he wished to do so. Personally, I have never in my life put in so much study and accomplished so little. One would think that by this time I should be able to speak and write the language fluently, but such is not the case and I believe I am about the average. It requires eight hours a day of constant study; and the continuous mental effort is bad, for you do not find the diversions that you find in other countries. In other words, for four years you must keep your nose to the grindstone and "bone" away in order to become completely absorbed in the language, the customs of the country, and the ways of thinking in order to get the best results from your study. You do not attend a school as does the language student in China. The instructors come to your house and study with you individually. For these instructors you are allowed thirty dollars a month, and it takes all of that for two instructors for two hours a day. You will have to buy all your books yourself as there is usually no allowance for them. I think I have put out about fifty dollars of my own money for books, and there are many more that I desire. This instructor's allowance is all you receive in addition to your regular pay and allowances. It is Colonel ——'s idea to have language students stay in Tokyo the first year and later to go to some small town in the interior where there are few or no foreigners so they can mix more with Japanese. In the fourth year of your tour you will be attached to a Japanese regiment, usually somewhere in the interior. You are examined every six months, and that is the only time you have to report to the office. Occasionally you may have to attend some ceremony or social function, but these are few. The rest of the time you may do practically as you please, go anywhere you please, and live where you please, subject of course to the Attaché's approval. This is the most pleasant part of the detail, in that you do not have someone constantly over you and you have practically all the freedom you wish.

There is also an over-rated importance attached to the diplomatic privileges of a language student. Many think that you constantly hobnob with members of the peerage, diplomatic corps, and socially elect. That is not quite the case. Of course, you are on the list and entitled to many privileges, but whether you

receive invitations to private parties, etc., depends upon you and upon your pocket-book. The average language student cannot go around very much on his pay, nor is he much courted unless he happens to have a most pleasing personality and demeanor. The majority of us, both British and American, never fool with the social game for two reasons—we cannot afford it, and we cannot spare the time away from our studies. If you have any social ambitions leave them behind.

You are a married man. That has some good points in your favor and again it has some bad points. The Colonel's words of yesterday will explain this. He said, "A married man will be more settled than you bachelors and consequently more contented, but on the other hand he will be more or less tied down to his family, which will not allow him to mix as freely with the Japanese as does the bachelor." Then, too, more than likely he will have financial worries unless he has a private income. There are no amusements here as you find in other countries. An occasional dance, with no young girls, and a game of bridge are about all we find to do. For that reason, bachelors are not very contented, but so far as that goes, not much more discontented than the married people. Recently four married couples and three bachelors formed a compound of our own in a suburb of Tokyo, but the Colonel is breaking it up as it is not very conducive to study and to association with the Japanese. There is an American school here where you could send your children. You will receive medical attention wherever you are, you know, but when on detached service you will not receive it for your family unless you are near some army hospital, and there are none of those here of course.

Now for living conditions:

Houses.—Foreign style houses are very scarce, and when they are obtainable the rents are high—anywhere from 250 yen up, depending on the size and location. The majority of foreign houses are occupied by their owners. In the suburbs, as now in Omori, you can get a foreign house *sometimes*. I pay 150 yen for mine and live with three other fellows, but this is an exception since the owner is a friend of ours. I know of another little semi-foreign house near here that rents for 100 yen, but there is always a long waiting list for such a house. The best bet would be a Japanese house, and most foreigners live in such houses. In Tokyo a house large enough for you would cost you about 100 yen, and even at that might not be in a very nice neighborhood. None of the houses are furnished—not even a bath tub, but Japanese wooden baths are cheap and I like them better than foreign. Only in the center of Tokyo is there running water. Other places use wells, which necessitates boiling all drinking water. All have electricity and many have gas for cooking purposes, as well as for heating. It is a custom in Japan to require a certain amount of money as a deposit when you rent a house, usually three or more month's rent. This does not apply on the rent, but is supposed to be returned to you when you vacate. No lease is required, so you can vacate any time you wish unless you promise to stay a certain length of time. So when you get here you will need enough money for such a deposit. One of the reasons why foreigners do not mix more is, I believe, due to the housing question and to the fact that usually they are all so far apart. There is no special foreign section as there are in many cities in the Far East. Heating is by gas, oil, or stoves—no steam heat.

Furniture.—Wicker furniture is the best, but I would bring what I had providing it was not too heavy or too valuable. Here, wicker straight chairs are around seven yen and arm chairs are from ten to fifteen yen. Chinaware is very cheap so I would bring none. Same applies to glassware. Outside the above, do not depend on buying anything here. Bring kitchen utensils, silver, table

linen, easy chairs, tables, beds, bedding, mattresses, and anything you might need. Supervise the packing very closely.

Clothing.—You wear civilian clothing all the time. You will need both a dinner jacket and evening clothes, and your wife corresponding things. A morning coat is unnecessary. Bring quite a supply with you for the whole family as in the long run that will be cheaper than buying here. A man's suit costs about 110 yen. There are beautiful materials to make women's and children's clothes (and cheap) but they always show their Japanese origin and are not a bit smart. Women's hats are awful. It would be best for both you and your wife to establish relations with some shops in the States so you can order from time to time what you will want. Men's socks are the biggest trouble here. Japanese shoes are not very good and cost as much as those at home. As for uniforms you will need but one for ceremonies, etc. At Manila, get two suits of Hong Kong khaki, two white uniforms, and a white mess jacket. They are much cheaper there than in the States or here. Moths are awfully bad here, so it would be well to bring some moth-proof bags or covers. Bring a supply of gloves for both yourself and wife as the imported ones here are expensive. It is cold in winter and hot in summer, so you would need about the same clothes that you would in New York City.

Servants.—Cooks, 45 yen; amahs, 35 yen; second amahs, 30 yen. All of them require constant watching. Women cooks are better in this respect than men and you can place more confidence in them. Men cooks are slightly more expensive, as far as salary goes, but far more so when you compare the bills. As a rule they are not very economical. A woman here does not lose face by going into the kitchen but, on the other hand, she is respected for it. The Japanese wife, even in wealthy families, either cooks her husband's food or supervises its preparation.

Food.—Comparatively poor, since you have no fresh vegetables, etc., as at home. No fresh milk. There is a large duty on all imports such as foreigners eat, so your food will cost you about double what you are paying now. Meat is about double. Fish plentiful and cheap. Chickens and other fowls cheaper than in the States, but usually they look half starved. Eggs about the same as in the States. Tobacco no good. Mail yourself some from Manila and when you get here you can make arrangements to have it shipped monthly from Shanghai.

Entertaining.—Practically none expected from a language officer. All depends upon yourself and your pocketbook. Here in the mess we figure about five yen per person for dinner—nothing elaborate.

Toilet articles, etc.—Easily obtainable.

You ask how much you can live on. That is a very difficult question to answer. In the Army we have three majors, two captains, and four lieutenants. None of us are saving any money. The majors are constantly complaining of the expenses. Living in a mess of four it costs me about 230 yen actual household expenses. When I lived with only one other chap it cost about 300 yen. This includes only actual household expenses. Outside expenses vary with the individual. The day of living cheaply has gone, and this applies to the Japanese as well. I would say that your household expenses would run you 500 yen a month and at that you would not be able to have many guests in for dinner. Normal exchange is two yen to the dollar. The rate now is about 47 but that might go back to par. So you can see for yourself just how you will stand if you only have your pay. Were you a bachelor you could do it, but I don't know about a married man, as he has many responsibilities about which I know nothing. There are always things that you want to buy and places to which you want to go that

require money, and while you are here and have the opportunity you really should. You will notice that I have stressed this financial side of the thing very much, and I believe rightly, for if you, as a married man, were to try to live here in Japan in any degree of comfort, I am sure you would have to economize and could not go around as much as you would like to.

I hope that you will take this in the spirit that I have written it. You asked certain questions and I have endeavored to answer them, at the same time stressing certain points that I think important to you as well as to others. I now have several questions to put to you.

Have you four years to spend on the detail before you become Manchued?

Can you spare four years away from your branch of the Service?

Have you any special adaptation for languages?

Have you any prejudices against Japanese or Orientals in general?

Have you a private income or is your salary large enough to maintain your position here?

Just why do you wish the detail?

And last, but not least, do you feel that you could put seven or eight hours daily for four years in concentrated study?



BATTERY "L," 51ST ARTILLERY, NEAR ST. JEAN. A GOOD EXAMPLE OF THE USE OF CAMOUFLAGE

MILITARY NOTES

Russia

FOREIGN LEGION IN THE RED ARMY.—The organization of a Foreign Legion in the Red Army is progressing rapidly. The center of the formation is at Tula, to which place approximately 12,000 foreigners have been transferred from the Red Army. Temporarily, the Foreign Legion is headed by an officer of Polish nationality whose name is Gajzewicz. The position of Chief of Staff of the Foreign Legion is occupied by a Czech, named Kryga. The formations organized at Tula are composed mostly of Czechs, Latvians, and Poles, who have previously belonged to divisional detachments which are being organized.

In addition to five regular battalions, a foreign school for noncommissioned officers and one Artillery Division have been formed at Tula.

In Perm, cavalry detachments are formed which are equipped with arms of Polish type. In Orenburg, cavalry detachments are formed composed exclusively of foreigners of the Mohammedan religion. The citizens of the Baltic States form a separate regiment. Another infantry regiment is formed by citizens of Finland; two brigades are formed of Ukrainians coming from Eastern Galicia.

After the organization is completed it is planned to transfer all Foreign Legions toward the Asiatic frontiers of Russia and station them in the Turkestan.

Italy

MARRIAGE REGULATIONS FOR ITALIAN OFFICERS.—Officers of the army, navy, aeronautics, and Royal Finance Guards, up to and inclusive of the rank of major and corresponding grades, in (a) in permanent active service, (b) at disposal of the Ministry, (c) "in aspettativa," must, prior to submitting a request for the King's approval to contract matrimony, give proof that they possess, in addition to pay, allowances and any military indemnity, a private income. The principal must be invested in government bonds or stocks and bonds guaranteed by the State. The principal and income must be mortgaged in favor of the future wife and offspring. The private income must amount to:

Lire 7000 for 2d Lieutenants and corresponding grades,
Lire 4500 for 1st Lieutenants and corresponding grades,
Lire 3000 for Captains and corresponding grades,
Lire 1500 for Majors and corresponding grades.

For the following the income for all grades is reduced lire 3000:

- (a) 1st and 2d Lieutenants of Carabinieri commissioned from the ranks.
- (b) Band masters.
- (c) Fencing masters.
- (d) Officers of the Royal Equipage Corps.
- (e) Officer specialists of aeronautics.

If the dowry of the future wife meets the conditions stated above the officer need have no private income. During marriage the officer has the right to collect the income. In case of legal separation the regulations of the civil code will be

applied. The principal, even when it belongs to the wife, can not be touched and the income can not be ceded or mortgaged to an outside party.

State control of the principal and income ceases when:

- (a) the officer has reached the rank of colonel or corresponding grade,
- (b) the officer ceases to be in permanent active service,
- (c) the officer is placed "in aspettativa" for reduction of the cadre and the Decree states that he will not be recalled to active service,
- (d) in case of death of officer,
- (e) in case of death of wife provided that there are no male offspring of minor age or unmarried daughters of minor age.

The Supreme Military Tribunal is charged with the examination of the proofs mentioned. The same Tribunal will act in case there is a change in the status of the principal. For other cases not foreseen, an ordinary Civilian Tribunal will act.

Officers who have contracted matrimony without complying with the regulations or who have submitted false statements will be dropped from permanent active duty. The Supreme Military Tribunal will act in these cases. As regards the approval of the King before an officer contracts matrimony the law remains as before.

United States

COST PER SOLDIER OF LEADING NATIONS.—During the recent meeting of the Preparatory Commission for the Reduction and Limitation of Armaments at Geneva, the Japanese delegates objected to the substitution of voluntary service for compulsory military service on the ground that the voluntary system was more expensive. Figures published by the League of Nations seem to support this contention.

COST OF ONE SOLDIER PER YEAR

<i>Nation</i>	<i>How Recruited</i>	<i>Cost in Gold Franc</i>	<i>Cost in U. S. Dollars</i>
United States	Voluntary	10,038	2,007.60
Great Britain	Voluntary	7,862	1,572.40
Germany	Voluntary	6,030	1,206.00
Italy	Compulsory	1,964	392.80
France	Compulsory	1,266	263.20

It is not apparent from the foregoing table how the figures were compiled. Unquestionably, the cost of an army based on the voluntary system of recruitment will be far in excess of that of an army where compulsory service is the rule. This factor must be taken into consideration when national defense budgets are compared. In addition, the standard of living in different countries must be considered.

The cost of pay and subsistence amounts to more than 40% of the total cost of national defense in the United States. Pay of the Army in the 1927 Budget is \$123,610,916, or slightly over 47% of the total appropriation for military activities. In foreign armies, as nearly as can be ascertained, the following is the case:

<i>Country</i>	<i>Per Cent of Military Expenditures for Pay of Personnel</i>
United States	47.0
Great Britain	30.2
Italy	30.0
Japan	28.1
France	25.0

Taking one soldier of the lowest grade in each of the armies considered above, the following table shows the annual cost of pay and subsistence.

Country	Pay	Subsistence	Total	Amount Less than U. S.
United States	\$252.00	\$128.57	\$380.57	
Great Britain	240.90	94.53	335.43	\$ 45.14
Japan	23.00	89.24	112.24	268.33
Italy	6.20	53.44	59.64	320.93
France	4.38	50.15	54.53	326.04

From the above table, it will be seen that the pay of one American soldier of the lowest grade will pay 58 French soldiers, 41 Italian soldiers, or 11 Japanese soldiers. It is also worthy to note that the cost of subsistence of one American soldier would feed 2.5 French soldiers, 2.4 Italian soldiers, 1.5 Japanese soldiers, or 1.4 British soldiers.

In order to see the effect of pay and subsistence on the Army budgets, the following table shows the Army budgets as they would be if all countries were required to pay and feed their soldiers on the American basis. For this study the pay of the lowest grade is taken as a factor as it is believed the pay of the other grades would be proportionately larger. The approximate enlisted strengths covered by the Army budgets are as follows:

ENLISTED STRENGTHS COVERED IN ARMY BUDGETS

Country	Army Budget	Enlisted Strength
Great Britain (a)	\$266,673,060	248,639
France	225,052,294	494,847
United States	261,146,731	128,302
Italy (a)	96,909,978	233,656
Japan	99,695,000	180,000

(a)—Includes $\frac{1}{2}$ Air Service.

If the other countries were required to pay and feed their soldiers on the American basis, the Army budgets would be shown in the following table:

Country	Army Budget	Increase	Total
Great Britain (a)	\$266,673,060	\$ 11,223,564	\$277,896,624
France	225,052,294	161,339,916	386,392,210
United States	261,146,731		261,146,731
Italy (a)	96,909,978	74,987,220	171,897,198
Japan	99,695,000	48,299,400	147,994,400

(a)—Includes $\frac{1}{2}$ Air Service.

France

FIFTIETH ANNIVERSARY OF THE FOUNDING OF THE ECOLE DE GUERRE.—The fiftieth anniversary of the founding of the Ecole de Guerre occurred on May 8 last. At the ceremony, the President of the Republic, the Minister of War, four Marshals of France, and a number of general officers were present. General Hering, commanding the school, made a speech in which he claimed that the school had fulfilled the object for which it was created. During the last war it had given its full measure. Former professors of the Ecole de Guerre had furnished the following:

- 11 Commanders of Armies or Groups of Armies,
- 2 Commanders-in-Chief of the French Army,
- 1 Commander-in-Chief of the Allied Armies.

The school had also prepared for their duties the staffs whose devotion to duty and professional attainments had made them indispensable aids to commanding generals.

One-fourth of the officers who graduated before 1914 were killed in battle: 21 generals, 108 colonels and lieutenant-colonels, and 115 majors.

In spite of the many present difficulties, the school continues its efforts to fulfill its rôle; it seeks to combine the precision of scientific investigation with elevation of character. The Ecole de Guerre is today the center of study from which, little by little, the teachings of the last war are brought to light.

Among the students are fifty foreign officers belonging to twenty-four different nations.

The President and the Secretary of War both made brief speeches of compliment and congratulation, and the ceremony was terminated by bestowing upon General Debeney, Chief of Staff of the Army and former Commander of the school, the *Medaille Militaire*—the highest military distinction that can be given an officer.

Japan

SPRING MEETING OF THE RIDING ASSOCIATION.—As a general rule we are not accustomed to thinking of the Japanese as experienced horsemen participating in the strenuous riding events affected by the mounted services of western nations. A brief description therefore, of the spring meeting of the Riding Association held at Narashino under the auspices of the Cavalry School may prove interesting.

This Association is sponsored by the Cavalry School, its main purpose being the encouragement of horseback riding and interest in the horse and the Cavalry School in general. For this purpose the military authorities are very generous in their loan of horses and equipment and in providing facilities for all civilians who desire to enter the various competitions. Prizes are given for each class, for the most part contributed by civilians. Quite an event is made of this meeting, it being attended by members of the diplomatic corps, high army officers, and influential civilians who are interested in horseback riding. A large crowd attended the meet, and the program presented was such as to interest greatly the people who attended.

Instructors and special students from the Cavalry School participated in the various exhibition events, and in a few cases officers contested with a small group of special civilians who own their own horses in riding events. The exhibitions of these officers and special civilians were of a very high order and showed excellent training of both the horse and rider. The program was along the usual lines of horse show events, and included some very excellent exhibitions by the instructors and other graduates of the school.

To show the interest taken by civilians in the meet, it may be noted that there were more than 200 entries of civilians in a six kilometer paper chase, troop horses being used. In the civilian special class jump there were 21 entries; for gentlemen civilian jump, 95 entries; for student and riding club jump competition, 51 entries; for the musical chair ride, 94 entries (civilians); and for ladies jump, 9 entries. In all these cases army horses were used, except in the case of special class civilian jump where private horses only were used.

For the officers' race, a course of fourteen jumps was laid out, the hurdles averaging one meter in height with several 1.30 meters. The obstacles varied from the single brush fence to a triple jump of 0.90 meters with 4.50 meters between hurdles. The Association is making a success of encouraging good horsemanship in the cavalry service.

COAST ARTILLERY BOARD NOTES

Communications relating to the development or improvement in methods or material for the Coast Artillery will be welcome from any member of the Corps or of the Service at large. These communications, with models or drawings of devices proposed, may be sent direct to the Coast Artillery Board, Fort Monroe, Virginia, and will receive careful consideration. R. S. ABERNETHY, Colonel, Coast Artillery Corps, President Coast Artillery Board.

Projects Initiated During the Month of June

Project No. 468, Comment on Revision of T. R. 310-136.—As a result of a recent inspection, by a member of the Board of Engineer Equipment, of searchlights assigned to the 61st Coast Artillery (A. A.), it was believed that certain statements contained in T. R. 310-136, "Description of the Operation and Care of Mobile Searchlight Unit, Cadillac Chassis and Power Unit, and 60-inch Open Type Searchlight," were being misinterpreted, and certain changes in those Training Regulations were prepared and submitted for consideration and comment by the Coast Artillery prior to issue.

Project No. 469, Blankets for Service Test.—Two blankets (one Marine Corps type and one Navy type) were sent to the Coast Artillery Board for examination and recommendation as to whether either of them offers sufficient merit to warrant consideration when funds become available for service test of blankets.

Project No. 470, Reiersen Percentage Fuze Corrector.—1st Lieut. J. E. Reiersen, 8th Coast Artillery (H. D.), submitted to the Coast Artillery Board a Bracket Fuze Setter, M. 1916, modified for percentage corrections, with the accompanying table of range percentages.

Project No. 471, Firing Tables for 6-inch Gun, Models 1900, 1903 and 1905, Firing H. E. Shell, Mark II.—These tables, prepared by the Ordnance Department, were submitted to the Coast Artillery Board for examination and comment as to their suitability for issue to the Service.

Completed Projects

Project No. 460, Number Strips and Prediction Scales for Cloke Plotting and Relocating Board

I—HISTORY OF THE PROJECT.

1. Letters, dated April 6, 1926, from the Chief of Ordnance to the Chief of Coast Artillery on the subjects of "Cloke Plotting and Relocating Boards" and "Prediction Scales," and the 1st Indorsement to each of these letters are as follows:

1. Cloke boards issued to the service are equipped with sets of replaceable number strips graduated as follows:

<i>Yards per inch</i>	<i>Maximum range</i>
300	11,400
600	22,800
750	28,500
1500	57,000

2. Steps are being taken to supply sets of number strips graduated 900 and 1200 yards to the inch for use with the Cloke board assigned to the 14-inch Gun Railway Mount at Fort MacArthur. (O. O. 413.683/319—O. C. C. A. 413.6813/14B.)

3. Information is requested, if available at this date, as to the number and scales of strips to be issued with each Cloke board in the future, noting that it may be desirable to vary the strips to suit the armament served.

413.6813/V

1st Ind.

War Department, O. C. C. A., April 10, 1926—To President, Coast Artillery Board, Ft. Monroe, Va. (Through Commandant, C. A. School.)

For remark concerning the information requested in paragraph 3, basic letter.

1. In connection with a letter from this office under the same date on the subject of proper number strips to be issued with Cloke Plotting and Relocating Boards, information is requested as to the manufacture and issue of prediction scales to suit the scales in use on the plotting boards.

2. The Cloke boards issued to the service have been equipped with scales graduated 300, 600, 750, and 1500 yards per inch; and, in one case, arrangements are being made to issue scales graduated 900 and 1200 yards to the inch. This later issue is for the 14-inch Gun Railway Mount at Fort MacArthur. (O. O. 413.683/319—O. C. C. A. 413.6813/14B.)

3. Is it desirable or necessary to issue prediction scales to suit each set of number strips provided?

413.6813/W

1st Ind.

War Department, O. C. C. A., April 10, 1926—To President, Coast Artillery Board, Ft. Monroe, Va. (Through Commandant, C. A. School.)

1. For remark.

2. This subject should be considered in connection with the communication referred to in paragraph 1, basic letter, which was forwarded to you per 1st Indorsement, 413.6813/V, O. C. C. A., April 10, 1926.

2. In accordance with the foregoing instructions the Coast Artillery Board has endeavored to determine:

a. Whether or not it is desirable to continue to graduate the arms of Cloke boards 30 graduations to the inch or to have some other number of graduations to the inch?

b. To what scales should the replaceable number strips for Cloke boards be graduated?

c. Should the replaceable number strips issued with Cloke boards be varied to suit the armament?

d. Should prediction scales be issued to suit each set of number strips provided?

II—DISCUSSION.

3. In this discussion the board having a 38-inch effective radius is called "Short Range Cloke Plotting Board," and that having a 55-inch effective radius, "Long Range Cloke Plotting Board."

a. The Short Range Cloke Board has an effective plotting radius of 38 inches, and the arms have 30 graduations per inch. The Coast Artillery Board considers number strips having scales of 300, 600, and 750 yards per inch as satisfactory. With these scales the least readings are respectively, 10, 20, and 25 yards.

b. A scale of 900 yards per inch has a least reading of 30 yards and a scale of 1200 yards per inch has a least reading of 40 yards. These values are not believed to be satisfactory in that their use will tend to produce errors. It is the opinion of the Coast Artillery Board that the least reading in every case should be an integral divisor of 100.

c. It is not believed that a satisfactory degree of accuracy will be attained with a scale of 1500 yards per inch.

d. Consider the armament to be divided into two classes:

(1) The 14-inch railway and 16-inch guns which should be provided with Long Range Cloke Boards (it is understood that the long range board will have an effective plotting radius of approximately 55 inches).

(2) All other armament, with the possible exception of the 16-inch howitzer, which should be provided with the Short Range Cloke Board. It will be seen that, with arms graduated 30 divisions per inch, it will be impossible to provide scales the least readings of which will be integral divisors of 100, and obtain the maximum ranges required for some of the armament of the second class, as the 12-inch railway and 12-inch B. C. Guns.

4. a. The following tables show, for the Short Range Cloke Board, the scales, least readings, and maximum ranges obtainable with differential graduations of the arms:

20 Graduations Per Inch			25 Graduations Per Inch		
Scales	Least reading	Maximum range	Scales	Least reading	Maximum range
yards	yards	yards	yards	yards	yards
100	5	3,800	125	5	4,750
200	10	7,600	250	10	9,500
400	20	15,200	500	20	19,000
500	25	19,000	625	25	23,750
1000	50	38,000	1250	50	47,500

30 Graduations Per Inch			40 Graduations Per Inch		
Scales	Least reading	Maximum range	Scales	Least reading	Maximum range
yards	yards	yards	yards	yards	yards
50	5	5,700	200	5	7,600
00	10	11,400	400	10	11,400
00	20	22,800	800	20	30,400
50	25	28,500	1000	25	38,000
00	50	57,000	2000	50	76,000

b. A consideration of the foregoing indicates that the Short Range Cloke Board, with effective plotting radius of 38 inches, with arms graduated 40 graduations per inch and provided with sets of number strips graduated 200, 400, 800, and 1000 yards per inch, meets the requirements of all armament except the 14-inch railway and 16-inch gun, and possibly 16-inch Howitzers, better than any of the other combinations considered.

c. The Long Range Cloke Board with effective plotting radius of approximately 5 inches, with arms graduated 40 graduations per inch and provided with sets of number strips graduated 200, 400, 800, and 1000 yards per inch, should meet all requirements of the 14-inch railway and 16-inch guns.

d. A scale of 200 yards per inch is believed to be necessary in each case for sub-caliber practice.

e. One-fortieth of an inch is not believed to be too small a division for accurate rapid work.

5. The Coast Artillery Board believes that but one prediction scale is necessary with each Cloke Board regardless of the number of sets of replaceable number strips provided. On a prediction scale the graduations and their corresponding numbers are used rather as reference numbers in determining the rela-

tion of the travel during one predicting interval plus the time of flight to the travel during one predicting interval than as units in measuring distances. Any convenient arbitrary scale may be used for this purpose. Except for the case when the scale of the prediction scale is the same as that of the set of number strips being used, the word "yards" printed on the prediction scale has no meaning. Hence, if a prediction scale is to be used with number strips other than those of the same scale as the prediction scale the word "yards" should not appear on it.

6. The adoption of a standard predicting device and the issue of one of these devices with each Cloke Board should obviate the necessity of issuing any prediction scales. It is the opinion of the Coast Artillery Board that such a device eventually will be adopted.

III—CONCLUSIONS.

7. The Coast Artillery Board is of the opinion:

a. That Cloke Plotting and Relocating Boards in the future should have the arms graduated 40 graduations to the inch.

b. That there should be issued with each Cloke Plotting and Relocating Board, the arms of which have 40 graduations per inch, replaceable number strips graduated 200, 400, 800, and 1000 yards per inch.

c. That it is desirable to use no smaller scale than 1000 yards per inch.

d. That ultimately 14-inch railway and 16-inch gun batteries, and possibly 16-inch Howitzer batteries, should be provided with Long Range Cloke Plotting and Relocating Boards.

e. That only one prediction scale should be issued with each Cloke Plotting and Relocating Board.

IV—RECOMMENDATIONS.

8. The Coast Artillery Board recommends:

a. That the arms of both types of Cloke Plotting and Relocating Boards be graduated 40 graduations per inch.

b. That there be issued with each Cloke Plotting and Relocating Board, the arms of which are graduated 40 graduations per inch, sets of replaceable number strips graduated 200, 400, 800, and 1000 yards per inch.

c. That Long Range Cloke Plotting and Relocating Boards ultimately be provided each battery of 14-inch railway and 16-inch guns.

d. That but one prediction scale be issued with each Cloke Plotting and Relocating Board.

e. That, for purposes of uniformity, prediction scales be graduated 40 divisions per inch with zero at the center and graduations to be numbered at ten division intervals to the right and left of zero; fifties and hundreds to be emphasized as is customary; the length of the scale to be 12 inches.

V—ACTION BY CHIEF OF COAST ARTILLERY.

413.6813/W-1

1st Ind.

War Department, O. C. C. A., May 6, 1926.—To the Chief of Ordnance:

1. The proceedings of the Coast Artillery Board on Project No. 460 are inclosed herewith. The conclusions and recommendations contained therein are concurred in.

BOOK REVIEWS

The Dardanelles Expedition. By W. D. Puleston, Captain, U. S. Navy. United States Naval Institute, Annapolis. 1926. 7"x 10". 154 pp. Ill. \$2.50.

This account of the Dardanelles Expedition is an excellent study of the naval and military operations at Gallipoli. Especially admirable are the charts, fully supplementing the text, and showing the attacks and their various phases day by day.

The study is primarily intended for officers of the Army, Navy, and Marine Corps, but the author hopes it will also be found worthy of the notice of American statesmen who may be required to direct the destinies of our country in time of war. "All four classes are busy men, so the narrative has been compressed and fully illustrated in order that its contents can be quickly understood." In doing this, he has succeeded admirably. The book is not a critical analysis of this campaign setting forth sins of omissions or discussions of what should or should not have been done under various circumstances in both its conception and execution. In this respect it may prove disappointing to some readers. But it is a clear, concise, graphic exposition of facts, and opinions based thereon, which give one a detailed and comprehensive knowledge of this amphibious epic.

A brief review of the political background and a careful examination of the events leading to the naval attack orient the reader for the opening of the drama on February 16. The author is decidedly outspoken in his characterizations and criticisms of the principal actors in these events. He confesses it may appear useless stirring of dead bones to criticize gallant officers and famous statesmen already forgiven at home, but he considers it necessary in order that every phase of this great contest may be studied. It is believed, however, that he could have said all that is necessary about the facts without commenting on some of the leaders as he does. It is well to bear in mind the example of Metternich, who in writing of contemporary leaders presents wonderful pictures without an unkind word, even about Napoleon.

The naval attacks, beginning February 19 and ending March 18, are treated in detail, each phase of each attack being illustrated by an excellent chart. The author's comments on each attack are instructive. This part of the book is of exceptional value to Coast Artillerymen, as many interesting technical details of the fire action of ships and forts are set forth. As to the controversy that has arisen over the ability of the fleet to force its way through the Dardanelles, "it can be said, as definitely as any statement can be made of a hypothetical problem, that the fleet could not have forced the Dardanelles, and De Robeck was correct in desisting from the attempt." "The eternal question of whether or not ships can fight forts is apparently answered by an emphatic negative in this engagement, which tends to confirm the experience of Port Arthur, but in justice to ships it must be added that there is but one Constantinople in the world, and in other places the ships would have a better chance."

Then the Army took up the task. One can only admire the intrepidity and superb courage of the British soldier. Mistakes in leadership there were and serious ones, too, but in spite of all the British soldier carried on. The landings were

effected—a feat of arms outshining all precedent—the lines joined, and maneuvering room and much needed space for stores and supplies gained on the toe of the peninsula. But by April 28, the allies were fairly used up. Turkish reinforcements had arrived in time to stop their advance and from this time the Turks always had superior numbers.

Then follows the long period of marking time, with lack of reinforcements and suitable ammunition for guns, and political dissension in London. But this period is marked by several fierce battles, frontal attacks with limited objectives, in which the Allies were generally successful. These costly and almost useless battles and the plainly visible Turkish entrenchments in the Helles region had the important result of setting the direction of the August attack towards Sari Bair and Sulva.

The Allied plan for this attack conformed in principle to the requirements of the situation. It involved demonstrations at both ends of a 200-mile line, and against the center; a holding attack at Helles; a secondary attack at Suyla, while the main attack was entrusted to Birdwood's Anzacs, reinforced by four brigades. This sound decision might have produced results of vast importance had it been energetically carried out, for, their objectives once attained, the British could have reached Boghali by way of Bijuk Anafarta and would have become masters of the Strait, because all communications between part of the troops defending the Strait (Northern and Southern Groups) with the interior of the country, could have been cut off.

But the well-planned strategical surprise failed. The causes may be briefly stated: The various attacks were neither coordinated nor simultaneous; the forces that landed at Anafarta did not quickly and energetically throw into disorder the weak elements of the defense in that region; the Turks offered unexpectedly stubborn resistance and were successful in quickly assembling superior forces at vital points. By a hair's breadth it had failed and now nothing more could be hoped for without reinforcements so large as to affect materially the position in other theaters and to demand a reconstruction of the whole Allied war plan.

The brilliant manner in which the evacuation was carried out did much to restore the prestige the Allies had lost by their indifferent campaign, and the much dreaded loss of life did not occur.

Captain Puleston does not doubt, apparently, that the conception of the campaign was both brilliant and sound. It was a venture rightly aimed, but aimed without the completeness and energy of true faith. Its tragedy lay in the fact that success failed of attainment by only the breadth of a centimeter.

Captain Puleston's study is based on official accounts from both British and Turkish sources and the semi-official accounts by the principal leaders, and special effort has been made to insure accuracy in all facts stated. It is probably the most accurate and concise account of the naval attacks, of the effect of naval fire on forts and seacoast artillery fire on ships, and of the campaign as a whole. This study should be valuable to anyone interested professionally in combined military-naval operations.—A. H., Jr.

The Perils of Amateur Strategy. By Lieutenant General Sir Gerald Ellson, K. C. B., K. C. M. G. Longmans, Green & Co., Ltd. 1926. 4¾" x 7½". 152 pp. \$2.00.

In a brief but meaty volume, Sir Gerald Ellson points out historical instances of the dangers from civilian political control of military, naval, and aerial operations, and suggests, though vaguely, some remedies applicable, particularly in the British Empire.

The major part of the work is given over to a study of the faulty governmental organization blamed for the ill-fated Dardanelles adventure. It is related that Lord Fisher's plan was "the envelopment of Germany's northwestern flank from the sea," that his tremendous construction program was intended "for great projects in the Baltic and North Sea," and that the decision for the Dardanelles operations brought a "progressive frustration of" his "main scheme of naval strategy" and led to his resignation. The writer shows not only that expert advice was disregarded, but that conditions were such that military and naval experts were prevented from offering their advice. Other historical instances are cited, and the methods of Pitt in 1757 shown to have been effective.

The author's statement of the question to be answered is—

"What is the most efficient method of conducting the operations of war under a democratic form of government?"

and his answer—

"In the first place a clear definition of functions is above all things necessary to salvation.

"Secondly, the line of demarcation advocated must extend from top to bottom, throughout every portion of the constitutional machine that has to do with the conduct of war.

"Thirdly, whatever system is considered necessary for war must be adopted and practiced in peace."

In an interesting prefatory note the Right Honorable Viscount Esher, C. C. B., C. C. V. O., indicates his disagreement with much of the author's argument and sympathy with the broad conclusions. Viscount Esher believes that among other things there should be "a joint Staff College where officers of the three arms can be instructed in high strategy and combined tactics under the same roof * * *." This suggestion seems important enough for consideration in any country no matter what its form of government.

The military reader will find the history of the inception of the Dardanelles operation, the abandonment of the North Sea-Baltic scheme, and the disregard of the Alexandretta alternatives most interesting.

The reviewer takes the liberty of mentioning here "A System for the Conduct of War" by General Sir Frederick Maurice in the *Atlantic Monthly* for June, 1926, which follows parallel lines, and offers a more definite solution. The book and the magazine article are well worth careful study, and the two together far more valuable than either alone.—R. S. A.

Andrew Jackson's Campaign Against the British, or The Mississippi Territory in the War of 1812. By Mrs. Dunbar Rowland. The Macmillan Co., New York. 1926. 5¼" x 8". 424 pp. Ill. \$3.50.

This volume is presented with the primary purpose of emphasizing the activities of the troops of the Mississippi Territory in the second struggle with the mother country. It begins with a sketch of the early life in the Territory and its people, including an account of the marriage of General Jackson and Mrs. Rachel Donelson Robards. The War with the Creek Indians is treated in detail from its beginning to end. The latter part of the book is devoted to Jackson's campaign against the British along the Gulf Coast, beginning with the attack on Pensacola and culminating in the Battle of New Orleans. Throughout these campaigns Jackson was compelled to rely on the militia and volunteers from this section,

and this volume has particular value in that it presents a vivid picture of the type of soldiery employed. The story of this pioneer army led by this great leader of the purely American type is both fascinating and invigorating.

As a study of military operations the value of the work would be materially increased if a few clear maps were added. The authoress may not be an authority on military operations, but one point is clear: she knows well her Mississippi history. Her volume is highly entertaining.—C. S. H.

Elementary Tactics or The Art of War, British School. By Major R. P. Pakenham-Walsh, M. C., P. S. C., Royal Engineers. Sifton, Praed & Co., Ltd. 1926. 5¼" x 8½". 290 pp. 10 s. 6 d.

In his preface the author describes his work "as an attempt to put in practical form the collected teaching of the various text books" and states that he "has endeavored to steer clear of any crank teaching, to which everyone is liable to fall a victim if they study the subject for a while." And it should be noted here that the second quotation is not characteristic of the author's English, which as a rule is simple, clear, and concise.

In the introductory chapter the reader is given to understand that war should be classified as an art for the reason that "the object of science is knowledge, the objects of art are works." The next chapter undertakes to collect the Principles of War into a list in "a form easily remembered by the student." The eight principles so listed are: Maintenance of objective, Offensive action, Surprise, Concentration, Economy of force, Security, Mobility, Cooperation. Lacking "simplicity" this parallels the list given in our T. R. 10-5, but it may be noted that the principle of the initiative is missing.

There are chapters on the characteristics of Fighting Troops, Administrative Services, Higher Organization (British), Orders, Messages and Movements, and other orthodox subjects, a brief discussion of savage warfare, and a still more brief but interesting speculation as to "Future Developments in War."

The section devoted to "Tactical Schemes," or Map Problems, is worthy of close study, but the reader should keep in mind that the solution is only "suggested" and that "only a limited number of aspects of each operation can be considered." The reader's interest will be aroused by the use of tanks in the *rencontre* engagement of a reinforced brigade.

Altogether a useful work, fresh in treatment, broad in scope, and truly British—not German or French.—R. S. A.

The Strategy and Tactics of Air Fighting. By Oliver Stewart. Longmans, Green and Co., New York. 1925. 5¼" x 8¾". 195 pp. Ill. \$2.25.

Major Stewart has compiled a text book pure and simple, and as such it will find its value to the Air Officers and not to the casual reader from another branch, for, except to an officer of the Air Service, the book will be found exceedingly dry and hard to take.

Doubtless the author has presented sound tactical and strategical principles to the reader. Certainly he has been thorough. It is equally certain, however, that he uses the same illogical course of reasoning that many other Air writers follow. In describing the destruction of Audricq in 1916, he neglects to mention the repeated failures to destroy that same target in the years that follow. Why

should it not be destroyed as fast as constructed with the airplanes improving from day to day?

Had Major Stewart included more anecdote and illustrative narrative in his text, it would have wider scope and be more readable to the average officer.—B. F. H.

An Account of the Battle of Liao-Yang. By Major General Sir W. D. Bird, K. B. E., C. B., C. M. C., D. S. O. Gale & Polden, Ltd., Aldershot. 1926. 5½"x 8½". 66 pp. Maps. 3 s. 9 d.

This account of the Battle of Liao-Yang was prepared primarily for the benefit of the junior officer of the British Army studying for promotion. It is based on the British *Official History of the War*, the reports of the military attachés, *A Staff Officer's Scrap Book*, and information obtained from the Japanese General Staff during a visit to the battlefield. It deals first with the point of view and actions of the Russian Army, and then with those of the Japanese forces. Ten maps enable the reader readily to follow the course of the action. Like all of General Bird's works, it is clearly and directly written and, while it undoubtedly will serve its original purpose, it deserves a much wider circulation than its author originally contemplated.

La Topographie de l'Artilleur. By Captain Brock. Berger-Levrault, Paris, Nancy and Strasbourg. 1926. 5½"x 9". 142 pp. Ill. 5 fr. 50.

The author, feeling that the artilleryman became a topographer when he abandoned direct fire, has presented the essentials of topography from the point of view of the artillery. He says that there are not two topographies, one for the light artillery and one for the heavy artillery, but that in every case both will utilize the same processes. He does admit, however, that occasionally the light artilleryman will find it necessary, because of the early arrival and emplacing of the pieces, to open fire before having obtained his topographic data with a maximum of precision, for "topography should never delay the opening of fire."

Captain Brock divides the topographic problem into its three elements—determination of directions, or orientation (*problème de la direction*); determination of positions (*problème du point*); and determination of elevations (*problème du site*). Each of these, he then treats in an elementary manner, reducing to a minimum the number of processes explained, giving especially those usually employed within batteries and battalions. A number of examples show the more common calculations and the more usual combinations of methods. The book assumes familiarity with the battery instruments and, given such basic information, will be of value to any company officer who has not already studied orientation.

Our Navy and Defenders. By J. M. Colasanti. J. M. Colasanti, Portsmouth, Va. 1926. 8"x 10¼". 103 pp. Ill. \$3.00.

This interesting book might well be called a pictorial history of the Navy. On ninety-six pages are one or more pictures with essential data—pictures of naval heroes from John Barry and John Paul Jones to Dewey, Schley, and Sampson; pictures of ships from the *Bonhomme Richard* and *Serapic* through the long line of famous ships to the fleet of today; pictures of airplanes and dirigibles, of the Naval Academy and other shore stations, and of insignia of rank, decorations and badges, and flags and pennants. The book is clear and attractive in appearance, and is apparently the result of much painstaking effort.

Aircraft Instruments. By H. N. Eaton, A. M., and others of the Aeronautic Instrument Section, U. S. Bureau of Standards. Ronald Press Company, New York. 1926. 5½"x 8½". 269 pp. Ill. \$5.00.

This book is another volume of the Ronald Aeronautic Library. It is prepared for use either as a text book or for reference. Within its pages are complete descriptions of more than 175 types of aircraft instruments. It is true that this field is still in a stage of development, but the last ten years have witnessed a marked progress in the design and manufacture of these instruments. Here the required tests are of the severest, but the process of elimination and test has weeded out, to a great extent, the unsatisfactory, and now certain instruments are becoming standard. The authors have prepared a complete description of such instruments as those used for altitude and climb measurement, air and ground speed measurement, direction and position instruments, navigating or power plant instruments, and so on. Their usual practice is to give a general description followed by a detailed technical description. They discuss the advantages and disadvantages of the various types. In general, this volume, the pioneer in its field, is presented in commendable form.—C. S. H.

Practical Radio. By James A. Moyer and John F. Wostrel. McGraw Hill Book Co., Inc., New York. 1926. 5"x 7¾". 277 pp. Ill. \$2.00.

As its name indicates, this book is a practical radio manual. The first part is given to an explanation of radio and radio electricity, with a very good discussion of the antenna. The author then explains the crystal detector and its use in receiving sets. The vacuum tube, its uses and sources of power supply are taken up in detail. Two chapters are devoted to a very thorough discussion of audio and radio amplification. Much useful information as to selection is given for the use of the prospective owner and as to care and operation for the present owner of radio receiving sets. Sufficient data, instructions, and diagrams are included for the construction of receiving sets from a simple one-tube detector to the super-heterodyne. All of the values given for this construction have been tested by actually constructing the sets.

A "Radio Trouble Chart" is included, which simplifies trouble hunting in the receiver. Tables of tube data, battery charging rates, flashing voltages, and set characteristics make this book quite valuable to the set owner.

This book is a concise and handy reference book for the set owner or experimenter and will be quite useful to the instructor in the subject of elementary radio.—R. W. A.

Animal Heroes of the Great War. By Ernest Harold Baynes. The Macmillan Company, New York. 1925. 5½"x 8". 363 pp. Ill. \$3.50.

Ernest Harold Baynes went to Europe in 1919 and spent several months traveling in England, France, Egypt, Palestine, and other countries collecting information for this book. The book was started at once, but was not quite completed at the time of his death in 1925. For years, Baynes had devoted his energies to the study of animals. In that field he enjoyed a reputation as a lecturer as well as a writer.

In this book he has written with care and sympathy of the record of animals employed by the Allies on all fronts. He writes of the mascots, the horses, the fighting horses, the milk white horses of the Algerian Spahis, the camels, the oxen, the donkey, the dog, and the pigeon. His treatise on Allenby's Transport

Camels and the Fast Riding Camels was filled with surprises for the reviewer. Quite naturally the chapters on sentry dogs, messenger dogs, and other war dogs have abundant appeal to the human interest. Most of his chapters are illustrated by several true stories of animals in the war.

This book is highly recommended to the military man both for its professional value and for its pleasant reading matter.—C. S. H.

Memories of Lang Ago. By Lieutenant Colonel O. L. Hein, U. S. Army, Ret. G. P. Putnam's Sons. 1925. 6"x 8¾". 310 pp. Ill. \$3.75.

An interesting account of an officer's life in the Old Army. The early chapters deal with the author's youth in Georgetown during the last days of the Civil War and of his appointment to West Point by Mr. Lincoln. Succeeding chapters cover his life at the Military Academy, his frontier service and experiences, a detail as Military Attaché at Vienna, and a tour of duty at West Point as Commandant of Cadets.

The book is well written, and interesting to any one who knew the Army at this period.—W. W. H.

Four Years Beneath the Crescent. By Raphael de Nogales. Translated from the Spanish by Muna Lee. Charles Scribner's Sons, New York. 1926. 5¾"x 8½". 416 pp. Ill. \$3.50.

When the nations of the world began declaring war upon each other in 1914, Rafael de Nogales was at his home in Venezuela. Adventurous of spirit, a natural soldier of fortune, he had participated in many wars since his boyhood. He had been in Cuba and through South America; he knew northern Mexico; he had been wounded at Port Arthur. He determined to take part in the World War.

His Latin blood and his German education produced conflicting sympathies, but he first sought a commission in one of the Allied armies, beginning with that of Belgium. Receiving no offer other than a place in the French Foreign Legion, he reached Sofia, where he was refused by the Russians, before he gave up hope of getting into the war. About to start for home, he received and accepted an offer to become an officer of the Regular army of Turkey.

As Nogales Bey, then, he spent the next four years south of the Caucasus Mountains, the only Christian in a Mohammedan Army. He saw many things a Christian should not have seen, and he went some places he should not have gone. He spent some time around Erzerum, Mush, and Van. He descended the Tigris as far as Kut-el-Amara. He was all through Palestine, and for a time he commanded the Turkish forces in the Sinai Peninsula. The book is an account of his experiences and of his observations.

Nogales Bey found the Turk a fine soldier poorly officered and he is frank in stating who, among the senior officers, were particularly inefficient. The Armenian massacres were committed, he says, not by the Turkish regular army, but principally by the Kurds, of whom he thinks but little. Much of the blame for the massacres, however, he lays initially upon the Armenians themselves. The Arab he finds particularly worthless.

To the military student, the value of the book is doubtful. The chronology is not sufficiently detailed, the author moved frequently from one sector to another, and he makes no particular effort to present military operations as a military study. However, as a tale of travel and adventure, with archeological, historical, and racial sidelights, it is delightfully interesting and will undoubtedly be well received.

Porto Rico: History and Conditions, Social, Economic and Political. By Knowlton Mixer. The Macmillan Company, New York. 1926. 5½"x 8½". 329 pp. Ill. \$4.00.

During the quarter of a century of American rule in Porto Rico, that island has made tremendous strides socially, educationally, and politically. The death and sick rate has been very materially reduced, and the birth rate increased. Illiteracy has been lowered more than one-third. Commerce with the United States and with foreign countries has expanded enormously, and the assessed valuation of property in the island has more than trebled.

All this Mr. Mixer brings out in his book with a wealth of statistical detail. After a chapter devoted to the geography and climate, he devotes four chapters to tracing briefly the history of the island, showing its lack of preparation for development and thereby emphasizing the progress made by the Porto Ricans in a single generation. Subsequent chapters are devoted to the customs and habits of the people, economic conditions, social problems, the Jibaro (the small landowner of Indian origin), education, government, and American cooperation in the development of Porto Rico. An appendix gives details of transportation, hotels, roads, cost of living, summary of organic laws, labor legislation and wages, statistics of cities, and an extended bibliography. Every important aspect of Porto Rican affairs of today is presented in this volume.

The book is well written and profusely illustrated, and will assist greatly in adding to our information of this part of our nation. It contains information of interest and value to the general reader, the student, the traveler, the investor, and the business man connected with exports and imports.

How to Instruct in Aiming and Firing. By Major J. Bostock, O.B.E. Gale & Polden, Ltd., Aldershot. 1926. 4¾"x 7¾". 76 pp. Ill. 1 s. 8 d.

This popular little manual—now in its fourteenth edition—is intended to be of assistance to noncommissioned officer instructors of small arms firing. It is based on *Small Arms Training*, Vol. I, 1924, with which it is to be used, and carries the recruit through aiming instruction and firing instruction in two chapters. While it is full of excellent advice—particularly in Chapter I, "The Instructor," it should be used in our service only by experienced instructors because of differences between the American and the British Armies in weapons, in doctrine and in methods of instruction.

1944. By the Earl of Halsbury. Thornton Butterworth, Ltd., London. 1926. 4¾"x 7½". 302 pp. 7 s. 6 d.

The Earl of Halsbury pictures a war in 1944, involving a large part of the world. He makes use of no warlike devices or weapons not now in existence, but he shows them—particularly bombing planes—employed in such numbers as virtually to threaten the continuation of civilization. Many will claim that the menace on which the story hinges even now exists. However that may be, the author presents a vivid picture of the catastrophe which may follow an attack upon the civil population by an unscrupulous, prepared nation.

The tale is, of course, fiction, but it is not fantastic and it is of absorbing interest. It is told in an incisive manner, but not sensationally, and it contains much that is worthy of serious thought. The ending, though not exactly happy, seems to promise the rebirth and continuation of civilization. We recommend the book either as fiction or as a study of possibilities.

HOTEL ASTOR—NEW YORK
FRED'K A. MUSCHENHEIM
ARMY AND NAVY HEADQUARTERS

A Perfect Permanent Wave—Nestle's Circuline Process

Hair Dressing, Shampooing, Facial and Scalp Massaging, Manicuring, Permanent Wave, Marcel Chiropody, and all Beauty Work. First Class Line of Hair Goods Carried in Stock. Phone 224.

NICHOLAS' BEAUTY SHOP

3313 Washington Avenue

NEWPORT NEWS, VIRGINIA

(Patent Pending)

Application blanks
at Journal Office

Cable Address
USAUTO



**WRITE FOR
PARTICULARS**

**INSURANCE
AT COST**

For Officers, Warrant Officers, active and retired, and Nurses, of the United States Services

UNITED SERVICES AUTOMOBILE ASSN. (Formerly U. S. A. A. I. A.)
FORT SAM HOUSTON, TEXAS

STUDEBAKER

SALES :: SERVICE :: PARTS

Newport News Motor Car Company
INCORPORATED

B. J. STEPHENSON, *Secretary and Treasurer*

232-238 27TH ST., NEWPORT NEWS

101 E. QUEEN ST., HAMPTON



The MAGNOLIA TREE INN

LUNCHEON . DINNER
AFTERNOON TEA

TEA ROOM AND GIFT SHOP

ROOMS AND BOARD BY DAY OR WEEK

Special arrangements for card parties, etc.

TELEPHONE: Hampton 951

26 S. KING STREET

HAMPTON, VIRGINIA

EISEMANN'S

SHOES and HOSIERY
That Satisfy

2600 WASHINGTON AVENUE

NEWPORT NEWS, VIRGINIA

WHEN WRITING ADVERTISERS PLEASE MENTION THE COAST ARTILLERY JOURNAL

McEnany & Scott

ARMY AND NAVY UNIFORMS AND EQUIPMENT

High Grade Civilian Clothes

E. T. McENANY

For 43 years manager
Cadet Store, West Point

11 WEST 56TH STREET

Telephone
CIRCLE 2811

ROBERT SCOTT

For 35 years cutter
Cadet Store, West Point

NEW YORK

L. M. NEWCOMB

President

G. K. VANDERSLICE

Vice-President

THE OLD POINT NATIONAL BANK

PHOEBUS, VIRGINIA

*Foreign
Exchange*

*Travelers
Checks*

YOUR NEAREST NATIONAL BANK

and

U.S. GOVERNMENT DEPOSITARY

WE CAN HANDLE YOUR ACCOUNT

SATISFACTORILY TO YOU

*Safe Deposit
Boxes*

*Four Per Cent Paid
on Savings*

Call on us for anything in regard to Banking

P. McK. JOHNSON, *Cashier*

The Journal of the Royal Artillery

PUBLISHED QUARTERLY

*By the Committee of the Royal Artillery Institution,
Woolwich, London, S. E. 18*

SUBSCRIPTION, £1-0-0 PER ANNUM

WHEN WRITING ADVERTISERS PLEASE MENTION THE COAST ARTILLERY JOURNAL



Used by Uncle Sam's Expert Riflemen
HOPPE'S

NITRO SOLVENT POWDER No. 9

(Trade Mark Registered)

FOR CLEANING HIGH POWER (*Springfield*) RIFLES, REVOLVERS, MACHINE
GUNS AND FIREARMS OF ALL KINDS

Necessary to the success of all contestants for honors
at every Rifle Match

For sale at Hardware and Sporting Goods Stores and at Post Exchanges

FRANK A. HOPPE, INCORPORATED 2314 N. EIGHTH ST.
PHILADELPHIA, PA.

The Philippine Trust Company

Manila, P. I.

Commercial and Savings Bank
Trust Department

Special Attention Given to Army Accounts

M. H. O'MALLEY, *President*

Ford

WE SELL ANYWHERE

Ford

SHACKELFORD AUTO COMPANY

HAMPTON, VIRGINIA

Ford

Lincoln-Ford-Fordson

Ford



FERGUSSON MUSIC COMPANY

ESTABLISHED 1893

EVERYTHING MUSICAL

PHONE 566

2909-11 Washington Ave. NEWPORT NEWS, VA.



COMPLETE LINE OF MILLINERY *and* LADIES' READY-TO-WEAR APPAREL

MRS. M. B. GAMMON

13 Mellen Street

PHOEBUS, VIRGINIA



REGISTERED

N. S. MEYER, Inc.,

announce for the new lapel collar officer's blouse the finest insignia designs ever presented to the Military Trade. The designs are in keeping with the superior quality of N. S. MEYER, Inc., products.

On sale at all leading dealers
and Exchanges.

N. S. MEYER, Inc.

Insignia Specialists

43 E. 19TH STREET
NEW YORK

B. W. Wilson Paper Company

RICHMOND, VIRGINIA

*Distributors of WARREN'S
STANDARD PRINTING
PAPERS and
also all kinds of Printing Papers,
Cardboard and Envelopes*

STRATHMORE QUALITY PAPERS
for the Printer

NACHMAN'S DEPARTMENT STORE

*We extend to the members of the Association of Army and Navy Stores
the convenience of a charge account*

Washington Ave. at 30th St.

NEWPORT NEWS, VA.

BRITTON - ROWELL HARDWARE COMPANY

HARDWARE, PAINTS, OILS, PUTTY AND CROCKERY

Window Glass and House Furnishings

GOODYEAR TIRES AND TUBES

19-21 Mellen St., PHOEBUS, VA.

PHONE 559

WHEN WRITING ADVERTISERS PLEASE MENTION THE COAST ARTILLERY JOURNAL

CARRIES FARTHER LASTS LONGER

COLONEL GOLF BALLS

are famed for their extra long true flight—their enduring sturdiness—their accuracy and balance. This has been accomplished not by being merely different but by being better, finer. Today the quality is higher than ever before — yet there is no advance in price.

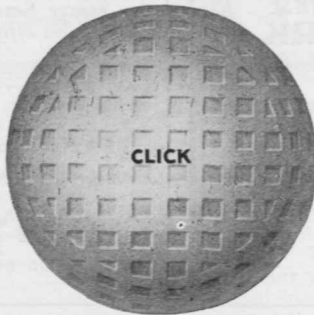

COLONEL GOLF BALLS

Click Colonel \$1.00 each, \$12.00 dozen;
St. Mungo Colonel 75c each, \$9.00 dozen.
Each one in dimpled and meshed markings.

ST. MUNGO MFG. CO. OF AMERICA

121-123 SYLVAN AVE.

NEWARK, N. J.

CUT BALLS REPLACED

The HEFFELFINGER COMPANY, Inc.

COAL, WOOD, LUMBER, and
BUILDING MATERIAL

FOOT OF
KING STREET

PHONES
23 and 58

HAMPTON, VIRGINIA



Centre
of New York's
Activities
**HOTEL
CONTINENTAL**
Broadway and 41st St.
NEW YORK
ROOMS
\$2.50 & upwards

The



HIGH INTENSITY SEARCHLIGHT

has been used exclusively by the U. S. Army and U. S. Coast Artillery for the past eight years. This fact alone proves the Sperry Searchlight as Supreme in *quality and efficiency.*

THE
SPERRY GYROSCOPE CO.
LONDON NEW YORK TOKYO

SPERRY
FOR BETTER NAVIGATION

Everything in Season

Tables for Ladies

SHERRILL'S RESTAURANT

THE PLACE FOR MEN AWAY FROM HOME

120 Mellen Street

Home-made Pies a Specialty

PHOEBUS, VA.

Post Exchange Market

FORT MONROE, VIRGINIA
TELEPHONE 315

Fresh Fruits and Vegetables. Everything in Season. Fresh Killed Chicken a Specialty. Deliveries: Morning and Afternoon

M. CARLI, *Proprietor*

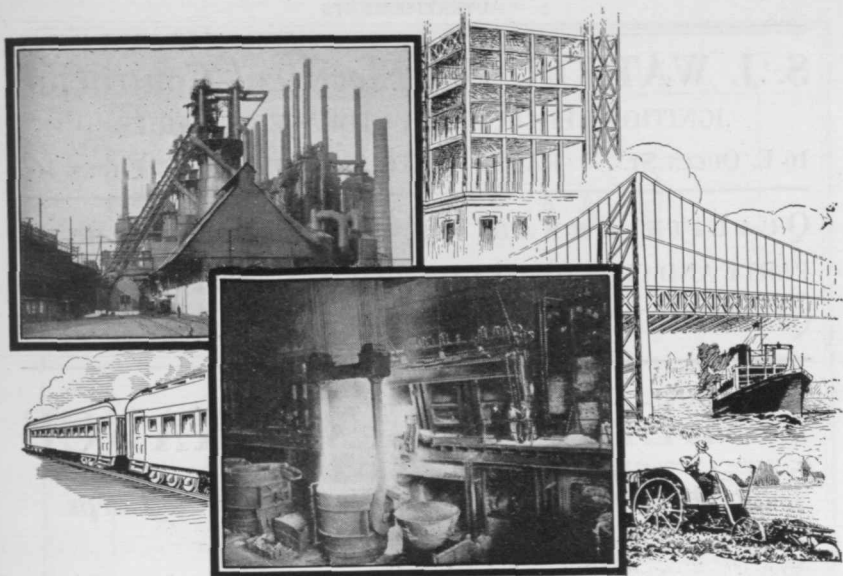

STEEL — FOR EVERY PURPOSE — IN ANY QUANTITY

STEEL is used in some form in practically every industry.

In the railroad industry, in the automotive industry, in the shipbuilding industry—steel is essential.

In the manufacture of machinery, in the erection of bridges and buildings, in the manufacture of agricultural implements—steel is a first requirement.

In the manufacture of ordnance material, in the equipment for practically every military and naval purpose—steel is indispensable.

The raw materials that go into the making of Bethlehem steel are extracted from Bethlehem-owned and -operated mines and quarries. Bethlehem-owned vessels and cars transport these raw materials to Bethlehem Plants, and complete control of every process in the manufacture—from ore to finished product—insures consistent quality. Extensive manufacturing facilities enable Bethlehem to supply steel for every purpose in any quantity.

For many years Bethlehem has shared in supplying the nation's demand for commercial steel, manufactured steel products and ordnance material.

BETHLEHEM STEEL COMPANY

GENERAL OFFICES: BETHLEHEM, PA.

PLANTS AT

Bethlehem, Pa. Steelton, Pa. Johnstown, Pa. Lebanon, Pa. Reading, Pa.
Coatesville, Pa. Lackawanna, N. Y. Sparrow's Point, Md.

BETHLEHEM

WHEN WRITING ADVERTISERS PLEASE MENTION THE COAST ARTILLERY JOURNAL

ADVERTISEMENTS

S. J. WATSON, JR., *Electrical Contractor*

IGNITION REPAIR

STORAGE BATTERIES

16 E. QUEEN ST.

RADIO—AUTO SUPPLIES

PHONE 166

QUALITY BREAD, ROLLS *and* PASTRIES

PARTY AND CLUB ORDERS SOLICITED

PHONE HAMPTON 75

QUALITY BAKE SHOP, INCORPORATED

56 W. QUEEN STREET
HAMPTON, VA.

I SELL LIFE INSURANCE

To Officers of the Army—Navy—Marine Corps

MY SELLING POINTS ARE:

Low Rates.

Suitable Policy Forms—Life, Income, Educational.

Most Liberal Disability Provision.

Monthly Premium Payment by Allotment.

Double Benefit in Case of Accident.

LAWRENCE C. CRAWFORD

MAJOR, U. S. A., *Retired*

601 Woodward Building

WASHINGTON, D. C.

JOE FRANK & SON

210 THIRTY-FIRST STREET
NEWPORT NEWS, VA.

Expert Dyers and Cleaners

Daily Deliveries to Fort Monroe

PHONE 2030

25 YEARS SERVICE TO OFFICERS OF THE CORPS

SHERWOOD INN BARBER SHOP

ANTONIO SARURRO, *Proprietor*

LADIES' WORK SOLICITED

SHERWOOD INN

FORT MONROE, VA.

WHEN WRITING ADVERTISERS PLEASE MENTION THE COAST ARTILLERY JOURNAL

HOUSTON

PRINTERS
PUBLISHERS
ENGRAVERS

De Luxe Printing at a Fair Price



HOUSTON BUILDING

HAMPTON. VIRGINIA



RADIOLAS—
RCA LOUDSPEAKERS
and RCA ACCESSORIES

WE are glad to announce that we have been selected by the Radio Corporation of America to sell and service RADIOLAS, RCA LOUDSPEAKERS, and RCA ACCESSORIES

Radiolas \$15 to \$575
RCA Loudspeakers \$18 to \$245

Convenient Time payment may be arranged

EVERYTHING IN RADIO

THE BOOKSHOP :: Fort Monroe, Virginia

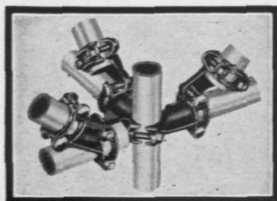
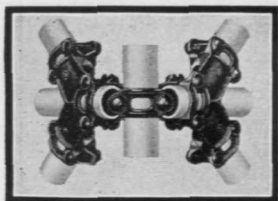

**Make it a Real Job
by using Westinghouse Pipe Fittings**

PIPE framework has increased attractiveness when assembled with Westinghouse fittings.

Structures erected by the use of these fittings have a finished appearance.

The great saving of time and labor in assembling, made possible by these pipe fittings, will practically pay for the cost of the fittings, themselves.

The good appearance, ample strength and economy of Westinghouse pipe fittings permit the use of pipe structures in many new ways.

Westinghouse Electric & Manufacturing Company
East Pittsburgh Pennsylvania
Sales Offices in All Principal Cities of
the United States and Foreign Countries



Westinghouse

Target Practice Essay Competition

PRIZES

First Prize	\$60.00
Second Prize	\$40.00
Third Prize	\$20.00

SUBJECT: A description of a preparation for and conduct of a target practice, or any phase or feature thereof.

PURPOSE: To secure for publication in the JOURNAL, the experiences and viewpoints of officers who recently have trained for, engaged in, or reported upon the results of target practices.

NOTE: This Competition is additional to and not in place of the JOURNAL'S Annual Prize Essay Competition.

CONDITIONS

(a) The competition is open to any officer of the Coast Artillery branch of the Regular Service, National Guard or Organized Reserves.

(b) The articles must be descriptive of practices held between November 1, 1925, and September 15, 1926, at batteries of 3-inch guns or larger caliber.

(c) Articles may relate to Fixed Artillery, Tractor Drawn Artillery, Anti-aircraft Artillery or Railway Artillery.

(d) Articles must not exceed 3000 words in length (approximately eight typewritten, double spaced pages of legal cap paper). Photographs, drawings, etc., may however, be submitted in addition if desired.

(e) All articles entered in the competition become the property of the JOURNAL.

(f) No competitor may submit more than one article.

(g) Articles must be received on or before October 1, 1926, and be addressed to the COAST ARTILLERY JOURNAL.

(h) Award will be made by a Committee of Award consisting of three officers to be nominated by the Editor.

(i) Articles must contain nothing to indicate authorship. They must be signed with a *nom de plume* and must be accompanied by a sealed envelope containing the *nom de plume* and the name of the person submitting same. These envelopes will remain in the hands of the Editor of the JOURNAL until after the award has been made by the Committee. They will then be opened by the Executive Officer of the Third Coast Artillery District.

F. W. DARLING, *President*

H. H. HOLT, *Vice-President*

W. H. FACE, *Cashier*

G. B. BRADFORD, *Asst. Cashier*

The Bank of Hampton, Virginia

HAMPTON, VIRGINIA

Located Near Fort Monroe, Virginia

“A FRIEND TO THE ARMY”

Capital, Surplus and Profits - over \$550,000.00

Resources over 3,000,000.00

The OLDEST BANK on the PENINSULA

You can, and a great many officers do, bank with us as easily by mail as in person. Write to us about it. Special attention given to all Army Accounts and we will be pleased to serve or advise in all financial or business matters.

4% Interest Paid on Savings Deposits

COAST ARTILLERY JOURNAL



SECOND COAST ARTILLERY
(HARBOR DEFENSE)

September

1926

17th Annual Prize Essay Competition

PRIZES

First Prize	\$125.00
Second Prize	\$ 75.00

CONDITIONS

(a) Subject to be chosen by competitor, discussing some phase of policy, tactics, or technique involved in the efficient accomplishment of the mission of Coast Artillery.

(b) Competition will be open to all readers of the JOURNAL.

(c) Award will be made by a committee of award, consisting of three persons, to be nominated by the Editor. If no essay submitted seems to the committee worthy of a prize, none will be awarded. Honorable mention may be made of any essay submitted which seems to the committee worthy thereof, but to which a prize is not awarded.

(d) All essays entered in the competition will become the property of the COAST ARTILLERY JOURNAL. These will be published, if valuable and interesting to JOURNAL readers.

(e) Copy must be typewritten, with lines double spaced, on one side of the paper only, and must be submitted in triplicate. If illustrations are included, one of the three copies thereof must be in the form of drawings, tracings, or photographs (not blue-prints nor brown-prints).

(f) Copy must contain nothing to indicate its authorship, must be signed with a *nom de plume*, and must be accompanied by a sealed envelope containing this *nom de plume* and the name of the writer. This envelope will remain in the hands of the Editor of the JOURNAL and, after award has been made by the Committee, will be opened in the presence of the Executive Officer, Third Coast Artillery District.

(g) Copy must be received on, or before December 31, 1926. It must be addressed COAST ARTILLERY JOURNAL and the envelopes must bear the notation, "Essay Competition."

PUBLICATIONS OF THE
BOOKSHOP
 Coast Artillery Journal
 Fort Monroe, Virginia

GUNNERY AND POSITION FINDING FOR ANTI-AIRCRAFT ARTILLERY75
HEAVY ARTILLERY MATERIEL:	
Part III: Ammunition	\$.25
Part IV: Pointing and Fire Control Instruments and Devices50
Part V: Signal Communications25
GUNNERS INSTRUCTION:	
Fixed Mortars (complete without supplement)50
Mine, with one supplement50
Fixed Gun, with one supplement50
Expert Gunners, Fixed Guns and Mortars50
Expert Gunners, Tractor Artillery50
<i>Antiaircraft:</i>	
Machine Gun Battery50
Gun Battery50
Searchlight Battery50
Expert Gunners50
Railway, complete without supplement50
Tractor Artillery, with one supplement50
SUPPLEMENTS	
3-in. Rapid fire	6-in. Disappearing.
5-in. and 6-in. Barbette.	8-in. Disappearing.
10-in. Barbette.	10-in. Disappearing.
12-in. Barbette, 1892 model.	12-in. Disappearing.
12-in. Barbette, 1917 model.	14-in. Disappearing.
155-mm. G. P. F.	8-in. Howitzer.
Additional extra supplements for any Gunners' Instructions10
OPERATIONS OF THE 29TH DIVISION:	
Volume I, American Documents	1.25
Volume II, German Documents	1.00
MECHANICAL MANEUVERS:	
Paper covers20
MILITARY MOTOR TRANSPORTATION, 414 pages:	
Board covers	1.25
Cloth covers	2.25
Flexible leather	3.50
HEAVY (Coast) ARTILLERYMAN'S FIELD POCKETBOOK:	
(The information every Coast Artillery Officer needs, in loose-leaf form, tables, formulæ, forms, and data sheets, 206 p.)	
Sheets without cover	\$1.50
Sheets with covers	from \$2.85 to \$6.50

WHEN WRITING ADVERTISERS PLEASE MENTION THE COAST ARTILLERY JOURNAL

Newport News Furniture Co.

5-100 - 5-102 WASHINGTON AVENUE

HAPPY HOME FURNISHERS

DIETRICH'S PLACE at Newport News

Will be always the Leading Restaurant of the Peninsula

DOWN SOUTH COOKERY

A PLACE BECOMING TO PERSONS OF CULTURE

The
EBBITT
HOTEL
H STREET AT TENTH
WASHINGTON · D · C

*The Newest Hotel in the
Nation's Capital*

All rooms have private bath or shower; running ice water and electric fans; Dixie Room offers real Southern cooking; Convenient for motorists

ROOMS \$2.49 PER DAY UPWARDS

BOOKLET WITH MAP OF WASHINGTON SENT FREE

HOWARD LITCHISON - Registrar
& CAMPERS' Manager



(17)
DYANSHINE
BARTON'S DY-
ANSHINE is the
best insurance
for your shoes.
Use it and your
shoes will look
better, feel bet-
ter and last lon-
ger.

BARTON'S
DYANSHINE

**BARTON'S
DYANSHINE**
TRADE MARK U.S. PAT. 1,011
DOUBLE SERVICE SHOE POLISH

MANUFACTURED BY
**BARTON MANUFACTURING
COMPANY**
ST. LOUIS, MO.

NEW YORK

CHICAGO

PARIS

Brentano's Inc.

Any Book in Print

BOOKSELLERS, ENGRAVERS AND STATIONERS

F and 12th Streets

Telephone Main 861

Washington, D. C.

THE PURITAN CONFECTIONERY

31 EAST QUEEN STREET
HAMPTON, VIRGINIA

PURE HOME MADE CANDIES AND ICE CREAM

*Home Made After-Dinner Mints, Salted Almonds, and Whipping
Cream a Specialty*

PHONE 856

I. LIPMAN & COMPANY

33rd St. and Virginia Ave.
NEWPORT NEWS, VA.

ARMY AND NAVY SURPLUS EQUIPMENT

PLUMBING AND MARINE HARDWARE AT REDUCED PRICES

DON'T BLAME IT ALL ON WINDAGE



A dirty gun minimizes your chances on the "Bull." A gun is clean only when the primer salts (potassium chloride) have been *completely* dissolved. Chloroil is the only solvent which will dissolve these salts and prevent after-corrosion. Chloroil cleans thoroughly with one application and there is no sweating out.

THE STAZON KIT

In addition to Chloroil, the Stazon Kit contains Stazon Gun Oil, Stazon Gun Grease and Stazon Rust-off. Everything necessary for the complete care and preservation of your firearms.

If not carried by the Post Exchange, send \$1.00 for the Kit, or \$.35 for Chloroil direct to

Gun Cleaning Headquarters

CONVERSION PRODUCTS CORP.

622 S. DELAWARE AVENUE

PHILADELPHIA, PA.

BROADWAY DEPARTMENT STORE

NEWPORT NEWS, VA.
3007-09 Washington Ave.

DRY GOODS, NOTIONS, MEN'S FURNISHINGS

HOUSE FURNISHINGS

EXCLUSIVE READY-TO-WEAR

AGENTS FOR McCALL'S PATTERNS

PHONE 736

BLOXOM BROTHERS

WHOLESALE FRUITS AND PRODUCE

23 MELLEEN STREET

PHOEBUS, VIRGINIA

WHEN WRITING ADVERTISERS PLEASE MENTION THE COAST ARTILLERY JOURNAL



**RADIOLAS—
RCA LOUDSPEAKERS
and RCA ACCESSORIES**

WE are glad to announce that we have been selected by the Radio Corporation of America to sell and service RADIOLAS, RCA LOUDSPEAKERS, and RCA ACCESSORIES

Radiolas \$15 to \$575
RCA Loudspeakers \$18 to \$245

*Convenient Time payment may
be arranged*

EVERYTHING IN RADIO

THE BOOKSHOP :: Fort Monroe, Virginia

Depository of the U. S. Government

**THE FIRST NATIONAL BANK
OF HAMPTON, VIRGINIA**

Capital	\$ 50,000.00
Surplus and Profits (earned) over	100,000.00
Total Resources over	1,800,000.00

**CONSERVATIVE
STRONG
ACCOMMODATING**

H. H. KIMBERLY, *President*
R. C. WINNE, *Cashier*

P. J. DRUMMOND, *Assistant Cashier*
J. C. ROBINSON, *Vice-President*

4% INTEREST ON SAVINGS ACCOUNTS