

# COAST ARTILLERY JOURNAL

PROPERTY OF THE US ARMY

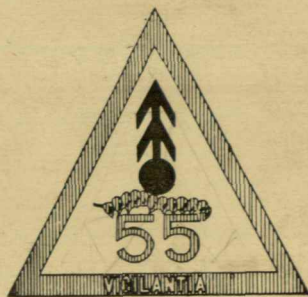

FIFTY-FIFTH COAST ARTILLERY  
(Heavy Tractor)

USAADS Library  
Fort Bliss, Texas 79916

July

1926

## Report Documentation Page

*Form Approved*  
*OMB No. 0704-0188*

Public reporting burden for the collection of information is estimated to average 1 hour per response, including the time for reviewing instructions, searching existing data sources, gathering and maintaining the data needed, and completing and reviewing the collection of information. Send comments regarding this burden estimate or any other aspect of this collection of information, including suggestions for reducing this burden, to Washington Headquarters Services, Directorate for Information Operations and Reports, 1215 Jefferson Davis Highway, Suite 1204, Arlington VA 22202-4302. Respondents should be aware that notwithstanding any other provision of law, no person shall be subject to a penalty for failing to comply with a collection of information if it does not display a currently valid OMB control number.

1. REPORT DATE <b>JUL 1926</b>	2. REPORT TYPE	3. DATES COVERED <b>00-00-1926 to 00-00-1926</b>			
4. TITLE AND SUBTITLE <b>The Coast Artillery Journal. Volume 65, Number 1, July 1926</b>		5a. CONTRACT NUMBER			
		5b. GRANT NUMBER			
		5c. PROGRAM ELEMENT NUMBER			
6. AUTHOR(S)		5d. PROJECT NUMBER			
		5e. TASK NUMBER			
		5f. WORK UNIT NUMBER			
7. PERFORMING ORGANIZATION NAME(S) AND ADDRESS(ES) <b>Coast Artillery Training Center, Coast Artillery Journal, Fort Monroe, VA, 23651</b>		8. PERFORMING ORGANIZATION REPORT NUMBER			
9. SPONSORING/MONITORING AGENCY NAME(S) AND ADDRESS(ES)		10. SPONSOR/MONITOR'S ACRONYM(S)			
		11. SPONSOR/MONITOR'S REPORT NUMBER(S)			
12. DISTRIBUTION/AVAILABILITY STATEMENT <b>Approved for public release; distribution unlimited</b>					
13. SUPPLEMENTARY NOTES					
14. ABSTRACT					
15. SUBJECT TERMS					
16. SECURITY CLASSIFICATION OF:			17. LIMITATION OF ABSTRACT	18. NUMBER OF PAGES	19a. NAME OF RESPONSIBLE PERSON
a. REPORT <b>unclassified</b>	b. ABSTRACT <b>unclassified</b>	c. THIS PAGE <b>unclassified</b>	<b>Same as Report (SAR)</b>	<b>132</b>	

# 17th Annual Prize Essay Competition

## PRIZES

First Prize .....	\$125.00
Second Prize .....	\$ 75.00

## CONDITIONS

(a) Subject to be chosen by competitor, discussing some phase of policy, tactics, or technique involved in the efficient accomplishment of the mission of Coast Artillery.

(b) Competition will be open to all readers of the JOURNAL.

(c) Award will be made by a committee of award, consisting of three persons, to be nominated by the Editor. If no essay submitted seems to the committee worthy of a prize, none will be awarded. Honorable mention may be made of any essay submitted which seems to the committee worthy thereof, but to which a prize is not awarded.

(d) All essays entered in the competition will become the property of the COAST ARTILLERY JOURNAL. These will be published, if valuable and interesting to JOURNAL readers.

(e) Copy must be typewritten, with lines double spaced, on one side of the paper only, and must be submitted in triplicate. If illustrations are included, one of the three copies thereof must be in the form of drawings, tracings, or photographs (not blue-prints nor brown-prints).

(f) Copy must contain nothing to indicate its authorship, must be signed with a *nom de plume*, and must be accompanied by a sealed envelope containing this *nom de plume* and the name of the writer. This envelope will remain in the hands of the Editor of the JOURNAL and, after award has been made by the Committee, will be opened in the presence of the Executive Officer, Third Coast Artillery District.

(g) Copy must be received on, or before December 31, 1926. It must be addressed COAST ARTILLERY JOURNAL and the envelopes must bear the notation, "Essay Competition."

ADVERTISEMENTS

# Books that will be of service in preparing for The Summer Camps



## NEW MILITARY LIBRARY

Red, White and Blue Manual	\$1.25	Field Engineering	\$1.50
Infantry Drill Regulations, illustrated and simplified	1.25	Scouting, Patrolling, Musketry	1.50
Tactics	2.75	Military Law	1.25
		Kerrick, Flag of the U. S.	1.50

## COAST ARTILLERY JOURNAL PUBLICATIONS

Military Motor Transportation	\$1.25	Operations of 29th Division	
Antiaircraft Defense	1.00	v. 1. American	1.25
Gunnery for Heavy Artillery	.75	v. 2. German	1.00
Gunnery and Position Find- inf for Antiaircraft	.75	Mechanical Maneuvers	.20

## SOME SPECIAL BARGAINS WHILE SUPPLY LASTS

Artillery Training, 1921	\$ .25	Coast Artillery Drill Regula- tion, 1917	\$ .25
Gas and Flame, Auld, 1918	1.00	Reconnaissance Sketching, Sherrill, 1912	1.25
Courts Martial Procedure, 1921	.50	Command, Staff and Logis- tics, 1925	.25
Plattsburg Manual, Ellis, 1917	1.00	Coast Artillery Materiel, Platt, 1917	.25
Military Primer, Marshall, 1916	1.00	Explosives, Weaver, 1917	1.00
N. C. O. Manual, Moss, 1916	1.00	G-I, Division General Staff, Pendleton, 1918	1.00
Machine Guns, Short, 1919	.25		
Hygiene and Sanitation, Keefer, 1918	.50		

## GUNNERS' INSTRUCTION

Antiaircraft Gun	Submarine Mine
Machine Gun	Motorized (Tractor)
Searchlight	Railway Artillery
Expert	Expert Guns and Mortars
Fixed Gun	Fixed Mortar

50 cents each postpaid

Expert Gunners' Instruction for Tractor (Motorized) Artillery 60 cents



# THE BOOKSHOP

FORT MONROE, VA.

WHEN WRITING ADVERTISERS PLEASE MENTION THE COAST ARTILLERY JOURNAL

**Newport News Furniture Co.**  
 3100 - 3102 WASHINGTON AVENUE  
 HAPPY HOME FURNISHERS

**DIETRICH'S PLACE at Newport News**

*Will be always the Leading Restaurant of the Peninsula*

DOWN SOUTH COOKERY

A PLACE BECOMING TO PERSONS OF CULTURE

**The EBBITT HOTEL**  
 H STREET AT TENTH WASHINGTON - D.C.  
*The Newest Hotel in the Nation's Capital*

All rooms have private bath or shower; running ice water and electric fans; Dixie Room offers real Southern cooking; convenient for motorists  
 ROOMS 12<sup>00</sup> PER DAY UPWARDS  
 BOOKLET WITH MAP OF WASHINGTON SENT FREE  
 HOWARD ERHISON - Supervisor  
 A. CUMPERT - Manager



Ask for **DYANSHINE**  
 Apply it according to directions, and see what wonderful service it gives.  
 It is to be had in most any shade.

**BARTON'S DYANSHINE**  
 DOUBLE SERVICE SHOE POLISH

MANUFACTURED BY  
**BARTON MANUFACTURING COMPANY**  
 WACO . . . . . TEXAS

NEW YORK

CHICAGO

PARIS

**Brentano's Inc.**

*Any Book in Print*

**BOOKSELLERS, ENGRAVERS AND STATIONERS**

F and 12th Streets Telephone Main 861 Washington, D. C.

---

---

## OLD POINT PRINT SHOP

43 WATER STREET  
PHOEBUS, VA.

ALL KINDS OF JOB PRINTING

STATIONERY for your personal and organization use. INDEX CARDS, BLANK FORMS, small, large and intricate. BOOKLETS. HOLIDAY MENUS. ORGANIZATION HISTORIES

---

## I. LIPMAN & COMPANY

33rd St. and Virginia Ave.  
NEWPORT NEWS, VA.

ARMY AND NAVY SURPLUS EQUIPMENT

PLUMBING AND MARINE HARDWARE AT REDUCED PRICES

---

## SALT AIR AND YOUR SMALL ARMS

SALT is the chief cause of after-corrosion, the most deadly enemy of modern fire-arms. Under ordinary conditions the salt is in the potassium chloride, residue of the primer. On the sea coast the salt in the air adds to the difficulty of effective cleaning—Chloroil is the only solvent which dissolves this salt completely. Used by all International teams representing the United States for the past three years—testifies to its efficiency.

### *The Stazon Gun Kit*

contains Chloroil, Stazon Gun Oil, Stazon Gun Grease, Stazon-Rustoff—everything necessary for the complete care and preservation of your small arms. If not carried at the Post Exchange, send \$1.00 for the Kit or 35 cents for Chloroil direct to



### *Gun Cleaning Headquarters*

## CONVERSION PRODUCTS CORP.

622 S. DELAWARE AVENUE

PHILADELPHIA, PA.

---

## BROADWAY DEPARTMENT STORE

NEWPORT NEWS, VA.  
3007-09 Washington Ave.

DRY GOODS, NOTIONS, MEN'S FURNISHINGS

HOUSE FURNISHINGS

EXCLUSIVE READY-TO-WEAR

AGENTS FOR McCALL'S PATTERNS

---

PHONE 736

## BLOXOM BROTHERS

WHOLESALE FRUITS AND PRODUCE

23 MELLEEN STREET

PHOEBUS, VIRGINIA

---

WHEN WRITING ADVERTISERS PLEASE MENTION THE COAST ARTILLERY JOURNAL



**DEER  
PARK HOTEL**  
*DEER PARK MARYLAND*

"HIGH UP IN THE ALLEGHENY MOUNTAINS  
*Where Spring Spends the Summer*"  
elevation of 2600 ft. insures a cool invigorating climate

18 Hole Golf course, Tennis, Saddle Horses,  
Swimming pools, Music and Dancing:  
Excellent table - Very moderate prices.  
200 Rooms - 100 Baths - 10 Cottages.

*Booklet sent upon request -*  
H. P. DUNCAN  
Manager

*Depository of the U. S. Government*

**THE FIRST NATIONAL BANK  
OF HAMPTON, VIRGINIA**

Capital . . . . .	\$ 50,000.00
Surplus and Profits (earned) over . . . . .	100,000.00
Total Resources over . . . . .	1,800,000.00

**CONSERVATIVE  
STRONG  
ACCOMMODATING**

H. H. KIMBERLY, <i>President</i>	P. J. DRUMMOND, <i>Assistant Cashier</i>
R. C. WINNE, <i>Cashier</i>	J. C. ROBINSON, <i>Vice-President</i>

4% INTEREST ON SAVINGS ACCOUNTS

# THE COAST ARTILLERY JOURNAL

Published as the Journal U. S. Artillery from 1892 to 1922

MAJOR ROBERT ARTHUR, C. A. C. . . . . *Editor and Manager*  
CAPTAIN D. L. DUTTON, C. A. C. . . . . *Assistant Editor*

Volume 65

JULY, 1926

Number 1

## CONTENTS

U. S. AIRCRAFT CARRIER LANGLEY . . . . .	<i>Frontispiece</i>
COAST ARTILLERY . . . . .	By COL. C. E. KILBOURNE 1
NATIONAL GUARD ENCAMPMENTS . . . . .	By MAJ. GEN. C. C. HAMMOND 7
A DISCUSSION OF SKY AND COAST DEFENSE . . . . .	15: By MAJOR R. R. WELSHMER
THE R. O. T. C. . . . .	By MAJOR P. H. HERMAN 31
THE ORGANIZED RESERVES . . . . .	By MAJOR S. F. HAWKINS 38
FRENCH COAST DEFENSES . . . . .	By COL. G. DUMONTET 43
RAILWAY COMMUNICATIONS AND FIRE CONTROL . . . . .	57 By CAPT. G. W. RICKER
EDITORIALS . . . . .	65 <i>Specialization—Writing an Editorial—Attention, Young Americans— Legislative Preparedness—The Army Housing Bill—Not Again, Thanks.</i>
PROFESSIONAL NOTES . . . . .	71 <i>A Proposed Method of Tracking Moving Targets Using Aerial Observa- tion—Coast Artillery Noncommissioned and Warrant Officer Personnel— A Fuze Range Percentage Corrector for Antiaircraft Artillery—Artillery Ordnance Development—Foreign Periodicals—Remington's New Rifle— T. R. 435-184: "Service of the Piece, 156-mm. G. P. F. Gun"—A Correction</i>
MILITARY NOTES . . . . .	93 <i>Military Training of Youths in Japan—Reorganization of the Italian Army—The Esthonian Army.</i>
COAST ARTILLERY BOARD NOTES . . . . .	98
BOOK REVIEWS . . . . .	107 <i>The Study of War—Mesopotamia Campaign, vol. III—Man and Weather— How to Live—Whitehead's Complete Auction Bridge—Digging for Lost African Gods—Whys of Auction Bridge—How to Write a Short Story— Army—The Esthonian Army.</i>

*Authors alone are responsible for statements in contributed articles*

Published monthly under the supervision of the Commandant, Coast Artillery School, by direction of the Chief of Coast Artillery, for the information of the Coast Artillery personnel of the Regular Army, National Guard, and Organized Reserves.

Terms: United States, \$3.00 a year; single copies 50 cents. Canada, \$3.25 a year; single copies, 55 cents. Foreign, \$3.50 a year; single copies, 60 cents.

Entered as second class matter at the Post Office at Fortress Monroe, Va. Acceptance for mailing at special rate of postage provided for in Section 1103, Act of October 3, 1917, authorized 3, 1920.

Copyright, 1926, by the COAST ARTILLERY JOURNAL.

Address: THE COAST ARTILLERY JOURNAL, Fort Monroe, Va.

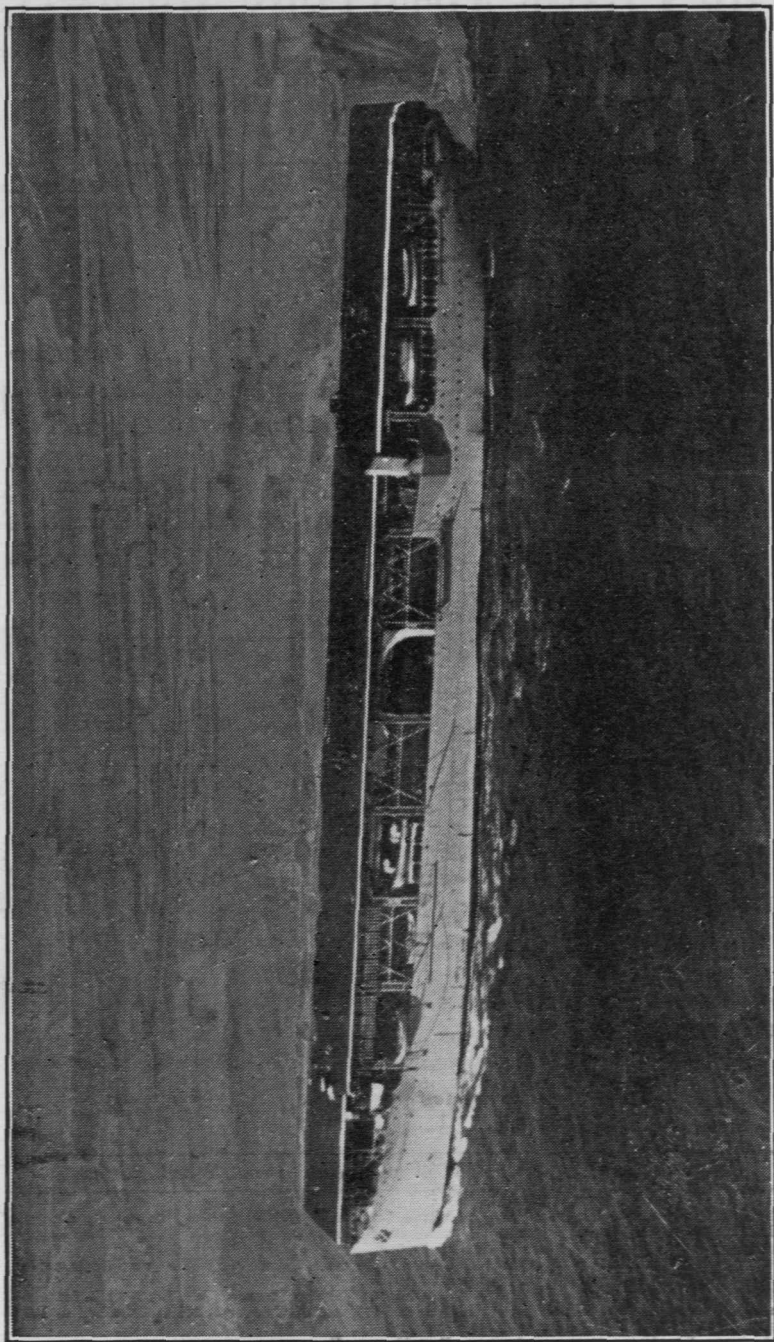

U. S. AIRCRAFT CARRIER LANGLEY

DISPLACEMENT, 19,360 TONS. LENGTH OVERALL, 542 FEET. BEAM, 65 FEET. DRAUGHT, 19 FEET. ARMAMENT, 4 5-IN. SPEED, 15 KNOTS. HORSEPOWER, 7152.  
CARRYING CAPACITY, 34 PLACES. CONVERTED FROM COLLIER, 1920-21.

# THE COAST ARTILLERY JOURNAL

Volume 65

JULY, 1926

Number 1

## The Coast Artillery\*

COLONEL C. E. KILBOURNE  
*Coast Artillery Corps*

THE reason I volunteered to give this address is that a prominent Congressman recently came to my office and advised that the Coast Artillery come out and state what was being done—that some of the statements made publicly that the activities of the Corps were obsolete or of little relative importance were having an effect upon the people and in the Congress.

\* \* \* \* \*

The system of harbor defense has been criticised. Now, General Coe has said that the Navy, not the Coast Artillery, should defend the big fixed battery against criticism, since, as long as possible adversaries have battleships, the major-caliber fixed gun ashore would be necessary. But the battleship itself has been classed as obsolescent. Is this so? I do not believe it; I have seen the supremacy of the battleship threatened three times. First by the torpedo boat with its automobile torpedo; the torpedo boat could be seen and the defense against it was found. Next came the submarine, and many believed this would drive the battleship from the seas, since it could neither be seen nor heard; nevertheless the defense was found. Now comes the bombing plane; this can both be seen and heard and, in my opinion, the defense against it will be found.

As long as there are battleships, the big-gun, fixed battery will remain the most certain and least expensive method of defending our harbors against sea attack.

a. I say the most certain, because—

1. It is always there; it cannot be tricked away by the skillful maneuver of an enemy, nor ordered away through some error of our own high command;
2. It is practically invulnerable;
3. It is independent of weather conditions;

\* Extracts from an address delivered before the Reserve Officers' Association of Washington, D. C.

4. It has proved itself in actual war, there being no instance where a well-manned, well-equipped land fortification has been overcome by naval attack.

b. I say the least expensive, because—

1. It sits on the ground and is inherently less expensive than anything that has to be moved around by machinery;
2. It does not deteriorate, while warships do deteriorate rapidly, and the life of aircraft is very short;
3. It needs no great plant for its maintenance;
4. It is capable of continuous, aimed fire. Calculate for yourselves the number of bombing planes it would require to maintain the rate of fire of a single 16-inch battery of two guns—two shots a minute, with shell weighing over a ton. Remember that a plane can carry only one 2000-lb. bomb—that, this dropped, the plane has no further offensive power until it returns to its base, lands, reloads, takes the air, gains altitude, and returns to the fight. Remember also that air tactics require the bombers to be preceded by pursuit and attack planes in actions against battleships, and you will form some idea of the enormous number of planes it would take to develop the fire power of our harbor defenses.

\* \* \* \* \*

Even should the battleship cease to exist as a war weapon, the *principles* of coast defense would not change. Economy might call for a different type of gun; but as long as the surface of the sea is used for military operations, as long as an army of invasion needs a harbor with wharves as a base, then the fixed gun ashore will remain the most certain and least expensive method of harbor defense.

This idea of doing away with coast fortifications is not new. When we began to develop our modern fleet many said: "Now we need no longer maintain these expensive forts; the fleet can defend the coast." This was correct—the fleet *could* defend the coast. But economists found that to maintain enough vessels to defend each harbor would cost much more than the forts, and strategists condemned tying down to local defense a force whose mission was to control the seas. So we continued our program of fortification. The same is true of the defense by aircraft. No one doubts that the coast could be defended by aircraft if we were willing and able to maintain enough of an air force to do it and were willing to assign, to a force essentially offensive in power, a mission purely defensive. Since we have paid for our coast fortifications already, and since coast fortifications have invariably proved effective in war, why seek some other means?

\* \* \* \* \*

You all know the uses of railroad artillery and heavy tractor-drawn artillery in land warfare—counterbattery, interdiction, and demolition.

The first two call for continuous, aimed fire; to replace the gun by bombers would parallel the situation described for the big harbor defense gun; it would call for a very large number of bombers to maintain the rate required. For demolitions the power of the plane to penetrate great distances gives it a marked advantage.

In coastal warfare, heavy movable artillery is very important. Foreign nations probably know our fortified and unfortified harbors. With only the fixed armament an enemy could plan, knowing what he was to meet; but with mobile armament he cannot anticipate its use—he may find the defended harbor strongly reinforced, or the undefended harbor protected by powerful armament.

There is certainly nothing obsolete or unimportant in this branch of Coast Artillery work.

\* \* \* \* \*

As to developments in sound ranging, I must confine myself to stating that marked improvement has been made in the method of locating by sound the enemy batteries and in adjusting our own fire by locating the explosion of our shell. In harbor defense we have held a very successful practice on a moving target without use of the terrestrial observation stations; our big guns can be used in fog or darkness. In the location of planes at night the tests of last summer have led to discarding much that was not practicable, and the development of improved methods. General Ruggles believes the time is near when firing data can be made available by sound locators, doing away with the necessity for searchlights.

. \* \* \* \*

The antiaircraft artillery has been especially the mark for attack. I am glad to state that my own conversations have convinced me that the adverse opinions are confined to a small percentage of our airmen, that the bulk of our fliers have a warm interest in the development of antiaircraft and realize its potentialities and its value to the aerial forces. Unfortunately, the different branches of the Army could live in anmity and brotherly love for a century without getting a line of newspaper comment, but just let someone start a row, come out with some violent attack, and the newspapers will headline it.

Now, it is inherent that the defense lags behind any new method of attack. World War records show that the number of shots to bring down a plane decreased steadily during the war till, in 1918, only about one-tenth the number necessary in 1916 were required. Also, these records show that approximately twenty per cent of the planes destroyed were destroyed by the antiaircraft gun—not so bad when you realize the gun could fire only while the plane was in range, while the

combat between aircraft could and did take place anywhere. To claim indifference to antiaircraft fire indicates closing one's eyes to the obvious.

There has been marked improvement in antiaircraft fire since the war. A well-manned, well-equipped battery can confidently expect to prevent a bomber from successfully attacking a limited target such as the Capitol building, the Navy Yard, or the railroad terminus. To

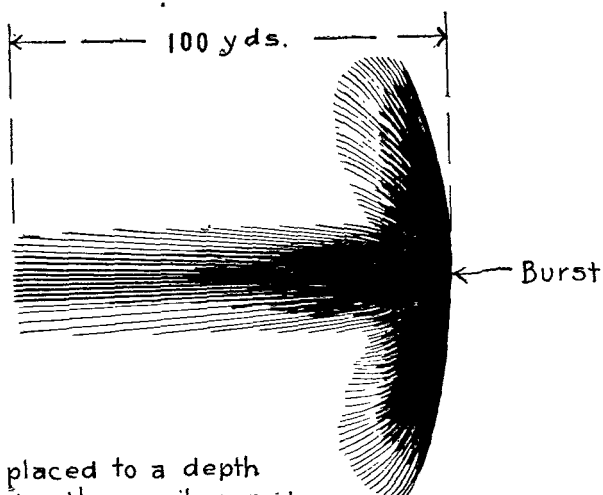

Note.

Screens were placed to a depth of only 100 yards; the number and size of fragments penetrating the last screen indicated that the danger space extended 50 yards further

FIG. 1. FRAGMENTATION 3-INCH A.A. SHELL

attack these the bomber must assume an altitude at which he can observe accurately, he must fly a course that will cause his bomb, when released, to travel to the objective. This is what made General Coe so positive in his statement that we could defend the limited objective while we could not prevent the bombardment of a city, which furnishes so large a target that a plane, flying at great height and in cloudy weather, could hardly fail to have its bombs strike somewhere in the city limits.

\* \* \* \* \*

Our conclusions, drawn from this year's practice, have been attacked as worthless. It has been stated that the percentage of hits claimed were made under "*Target Practice, and not War conditions.*" The most outstanding example of inconsistency I have ever known is furnished by the officer who criticised our practices at *moving* targets at a mean altitude of 5960 feet as being under target practice conditions and then

proceeded to write magazine articles and a book about bombing, at altitudes of 1500 to 2000 feet, the empty ships anchored off the capes.

I am prepared to demonstrate that the courses used at our target practice are really more difficult than those that might obtain in war. For the safety of the pilot and the plane we must have him fly across the course with certain limiting angles. Now, if the plane came directly toward the battery we would merely have to increase the elevation at a comparatively slow rate, and change the fuze settings. But a plane flying across the course calls for rapid traversing as well. Also, such a course requires a continual and a varying change in every element—deflection, elevation, and fuze settings—and these changes reverse themselves during the flight.

Some airmen stated that they saw the fuzes set in advance of the practice. They honestly believed that, somehow, the battery personnel knew in advance where the plane was to go. I have explained to some that the men were not setting the fuzes but merely breaking the shellac coating, a custom that is followed in war. Also, I showed them, as I am prepared to show you, that any attempt to set the fuzes in advance of the fire-control data would have resulted in certain failure. The fact is that the infantryman who directed the planes in the Tilden test, declined to inform anyone of the course, except the pilot, and gave it to him only just before he took the air. As far as it is possible to simulate war conditions in peace, these firings did so. The results are reliable.

\* \* \* \* \*

Our hits have been held up to public ridicule—called “hypothetical hits” and “theoretical hits.” Now, gentlemen, we are not trying to hit the plane with the shell; we are trying to burst the shell in a position where the fragments will damage the plane or pilot. Cast back to your war experience—how many times did you hear of a man being actually struck by a shell, and how many men did you know who were injured by the fragments of an exploding shell. All these last were injured by hypothetical hits, gentlemen. The graveyards of Europe hold thousands of men killed by “hypothetical hits”; the hospitals of the world have still large numbers of men disabled eight years ago by “hypothetical hits.”

\* \* \* \* \*

Our target has been criticised. There is no doubt that the hypothetical target used last year was not a scientific one. Some of the bursts we called hits would not have damaged a plane; on the other hand, a larger number we discarded would have damaged the plane. Simultaneously with our practice, the Ordnance Department was bursting shell in front of screens to determine the effect of fragmentation. The

results are shown in Figure 1. Based on these experiments we have recommended a new target. It is shown, with the old target, in Figure 2\*.

Also the Ordnance Department has developed a shell that gives a far more effective fragmentation than the one used in the tests, which was from World War stocks. In a lecture on the subject of anti-aircraft materiel; I recently heard an Ordnance officer state as follows:

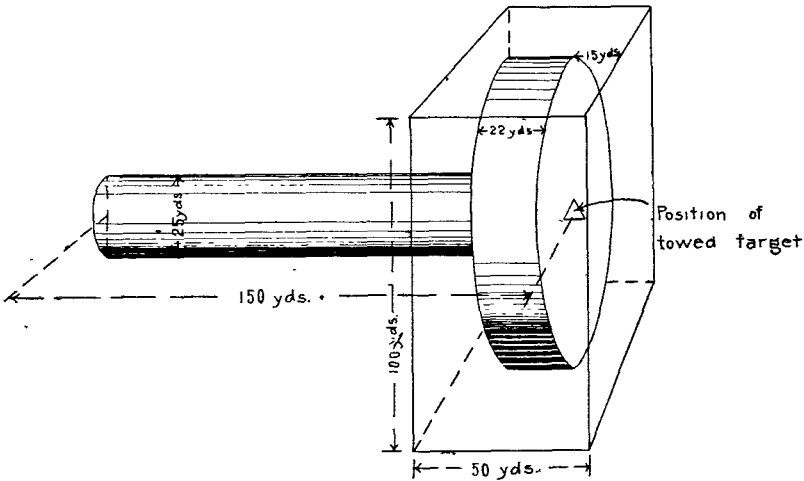

FIG. 2. NEW TARGET ENCLOSED IN THE TARGET PRESCRIBED FOR 1925

“The time is here when, for a bombing plane to come within range of a well-manned anti-aircraft battery, is to court almost certain destruction.”

\* \* \* \* \*

In my desire to make this talk as short as possible, I have dealt only on one side of the question—the Coast Artillery side. I do not wish to be understood as not appreciating the power of the aerial forces. I believe that nothing since the invention of gunpowder has more profoundly affected the Art of War than will the development of air power. I have the utmost respect for that arm of the service; I have even greater respect for those officers who select this hazardous branch for their life's work. This address is given merely in the hope that when you will advise the critic to hear the other side. Powerful as the air you hear the older arms criticised you will withhold judgment, that forces may become, I personally doubt that the bomber will ever displace artillery, that the attack plane will ever replace infantry, or that the observation plane will ever replace cavalry.

\* EDITOR'S NOTE: Since this lecture was delivered, the hypothetical target for 1926 has been materially decreased in dimensions.

# National Guard Encampments

MAJOR GENERAL C. C. HAMMOND

*Chief of the Militia Bureau*

A DISCUSSION of the methods and means used in the training of the National Guard, especially with reference to the fifteen-day encampments, seems particularly apropos at the present time. No attempt will be made to set forth the law and regulations in detail. The National Guard Regulations are now being promulgated in pamphlet form and officers desiring to acquaint themselves in detail with the law and regulations on any subject will be furnished, on request, insofar as possible, with the pamphlets pertaining thereto.

Before proceeding further it might be well to state that the National Guard—with few minor exceptions—is organized, armed, and equipped the same as the Regular Army, and during the annual encampment members of the National Guard receive the same pay, subsistence, and transportation as officers and enlisted men of like grades in the Regular Army engaged in similar service.

Training of the National Guard as a whole presents many difficulties. Some of these difficulties, such as wide dispersion of units, limited time available for instruction, and excessive turnover of both officers and enlisted men, are inherent in the system. To these can be added lack of funds for visits of instruction by instructors and sergeant instructors, curtailment of the number of armory drills, and forced reduction in strength, all resulting from insufficient funds. Incomplete equipment, due both to lack of storage space and inadequate appropriations, is also a factor. Generally not to exceed forty-eight armory drills of a duration of one and a half hours each can be held each year. We thus have a maximum of seventy-two hours of scattered instruction during eleven and a half months of the year to prepare for what might be called the final test, *i. e.*, the two weeks' encampment. When we consider that the mission of the National Guard, as set forth in mobilization plans, is to assist the Regular Army in the first line until the manpower of the nation can be mobilized and trained for offensive action, a superficial observer might decide we were placing our dependence on a broken reed. However, such is not the case. It is true that, as compared with the Regular Army, the time devoted to training is small, but where definite plans are made sufficiently in advance so all members are conversant with what is to be attempted, and if the objective is not too far advanced, it is surprising what can be accomplished.

From a training viewpoint the ultimate objective is the combat efficiency of the division, but the intermediate objective is the combat efficiency of companies and similar units, and the qualification—insofar as practicable—of higher commanders and staff officers by means of study and the solution of problems. Thus, both units and the higher command are prepared by the accomplishment of the intermediate objective to engage in training for the ultimate objective on M-day.

The intermediate objective is based on the following considerations:

- a. A thorough basic training is essential before an attempt to reach the ultimate objective will succeed.
- b. The ultimate objective cannot be reached in time of peace for reasons heretofore given.
- c. Mobilization plans contemplate a period of intensive training during which the ultimate objective can be approached.

The assignment of an intermediate objective is not intended to prevent progress beyond its scope but is intended to prescribe a goal that must be reached before more advanced training is undertaken. It is for higher commanders to determine, by means of tactical inspections, when the time has arrived for more advanced training.

Great progress has been made during the past year, mainly because this policy of basic training for the troops with higher training for the command and staff has been grasped and followed. Some divisions have already reached the point where training beyond the intermediate objective has been taken up and it is confidently expected this point will ultimately be reached by the entire National Guard.

The strength of the National Guard as originally contemplated by the National Defense Act was to have been some 23,000 officers and 800 enlisted men per Member of Congress by June 5, 1925. Since this program proved to be too ambitious, it was modified and at present contemplates a final strength of 250,000, including:

- 18 Infantry Divisions,
- 4 Cavalry Divisions,
- 18 Corps Artillery Regiments,
- 11 Coast Artillery Regiments (H. D.),
- 2 Coast Artillery Regiments (Hvy. Tr.),
- 8 Coast Artillery Battalions (H. D.),
- 7 Antiaircraft Regiments,
- 12 non-divisional infantry regiments, with certain other corps, army, and G. H. Q. reserve units.

The non-divisional infantry regiments consist, for the most part, of regiments organized prior to adoption of the modified program. It was not practicable to absorb all of these units in the eighteen divisions and they are now considered a special allotment, subject on call or draft

to service either as infantry or in any branch in which their services may be required.

The 250,000-man program contemplated arrival at that strength by July 1, 1926. However, inadequate appropriations necessitated a halt in the organization of new units, a reduction in the authorized strength, and a curtailment in the number of armory drills. As of March 31, 1926, the aggregate strength was 176,033 and comprised 2956 company or similar units at 1398 different stations. The foregoing illustrates the wide dispersion of the National Guard and the difficulties encountered in providing training points in sufficient number to avoid undue transportation costs with the attendant loss of time.

In time of peace the National Guard is essentially a State force. Except by mutual agreement between the States concerned a National Guard officer of one state has no authority over the National Guard of another state, irrespective of his rank. Some of the larger states (6) have been allotted a complete division but many divisions are allotted to two or more states. When, under the foregoing conditions, special allotments and corps, army, and G. H. Q. reserve troops are taken into consideration, the establishment of training points and the command thereof is somewhat complicated.

It is the policy to encourage the establishment of at least one camp in each state which will be under state control. Usually in such cases the camp site is either owned by the state or leased with an option of renewal for at least five years. However, in some states camp areas of sufficient extent are not available for use by Field Artillery and Anti-aircraft regiments. Coast Defense troops, if Harbor Defense, must have fixed armament and, if Heavy Tractor, must have a water area or target practice cannot be held. In order to make the maximum use of camp facilities, certain camps are used concurrently by other components of the Army of the United States such as Regular Army and Organized Reserves. In some few camps C. M. T. C activities are also carried on.

During 1925 the National Guard was trained at 86 different camps of which 55 were used solely by the National Guard and 31 were used concurrently by other components of the Army. A total of 152,970 officers and men attended these camps. Of this number 92,624 engaged in their field training at camps used solely by the National Guard, indicating that the average attendance at each camp thus used was approximately 1700. At first glance this may seem an uneconomical use of training camps. A camp can normally be used during four training periods between the Fourth of July and Labor Day. However, in view of the dispersion of the home stations of the National Guard, the location and number of camps established must be balanced against

APPROPRIATIONS  
NATIONAL GUARD  
 1808 - 1926

1200,000  
 Yearly  
 1808-86

400,000  
 Yearly  
 1887-99

1,000,000 - 2,000,000  
 Yearly  
 1900-08

2,000,000 - 6,000,000  
 Yearly  
 1909-14

1915<sup>16</sup> AVERAGE 10,000,000  
 1913  
 13,500,000  
 1918-17

39,000,000  
 1918

13,000,000  
 1919

20,000,000  
 1920

29,000,000 AVERAGE YEARLY  
 1921-26

30,879,252  
 1927

transportation costs and time lost in travel. Another factor is the necessity for providing adequate training facilities for the various arms of the service.

The camp facilities provided for the various camps at Federal expense vary within wide limits. Among the considerations affecting the funds allotted are: (a) the permanency of the camp; (b) the number of camp periods during which the camp will be used; (c) the natural advantages or disadvantages of the camp site; and (d) the availability of funds. Thus, we have camps varying in facilities from the barest essentials, such as a camp entirely of canvas with water, dry earth closets, and disposal of kitchen waste by burying or burning, to a camp with frame kitchens and mess halls, shower baths, sewer systems with officers' and enlisted men's latrines, tent floors, concrete roads, and frame buildings for use as camp headquarters and storage purposes. In some cases, existing structures remaining from the World War have been used. Some of the camps have been criticised as being too complete and tending to provide facilities more akin to a summer resort than to a camp. However, the standards of living are getting higher each year and this trend is reflected in the facilities provided at camps. There is also a growing conviction among students of the subject that discomfort is not essential to the acquisition of military knowledge. We may thus expect constant additions to the facilities provided at camps as funds become available therefor.

Training camps for National Guard Coast Artillery require, in addition to camp facilities, provision for long-range fire under conditions where it is impossible to ascertain just where the projectile is going to strike. The laying or aiming of the gun is only one of a series of operations carried on in sequence with strict regard to the time factor and if time is taken to check any one of these operations, the whole series must be repeated. This brings up the question of the adaptability of National Guard to the use of weapons requiring a very high state of training on the part of a few key men such as plotters and gunpointers. Early in the present century, when the first attempt was made to train National Guard in the handling of seacoast weapons, many doubted whether, under the handicaps inherent in the system, National Guard could ever successfully fire seacoast guns. It was argued that the turnover was too great and the time available for training insufficient. An analysis of the personnel of most National Guard organizations discloses the fact that while there is a large turnover, there is also a small grouping of enlisted men in each unit that continually re-enlist. All that remains is to select plotters and other key men from among this grouping who remain with the unit year after year in order to develop the key men in both range and gun sections

to a point where reasonable success is assured. As to the remainder of the gun crew, one might say that they are merely hewers of wood and drawers of water and can easily be trained in their respective duties. Wheeling an ammunition truck or carrying a bag of powder is not far different from the labor of a longshoreman in wheeling a barrel of fish or a mill employe handling a bag of flour. To state the proposition in a different way, the National Guard is better adapted to service in an arm where a high degree of intelligence and state of training is demanded for a few men, the remainder requiring but little training or intelligence, than where all the personnel of the organization must have a certain average degree of intelligence and all be brought to approximately the same state of training in order to function properly.

To return now to the subject of camps for Coast Artillery National Guard, it is necessary in addition to a camp site to provide armament, towing tugs, and a field of fire reasonably clear of commercial shipping for harbor defense troops. Heavy tractor regiments already have their armament but must have a location where their guns may be emplaced and, in addition, should have an area suitable for training tractor drivers. In the case of antiaircraft regiments, it is necessary to provide a clear field of fire in the shape of an equilateral triangle the sides of which are some 12,000 yards in length.

Harbor defense troops are invariably encamped in some coast fort where they make use of the fixed armament and installed fire-control apparatus. In the past only coast forts have been considered as suitable when they were in service. Since many coast forts are in the hands of caretakers, the choice was restricted somewhat and transportation costs were excessive. This year some coast forts will be used that are in the hands of caretakers. No objection is seen to this arrangement provided the equipment has been kept ready for service or placed in this condition prior to the arrival of the troops.

The field training of heavy tractor regiments presents difficulties in that several combinations must be sought. The essentials, in addition to a camp site, are:

- a. Water area reasonably free from shipping contiguous to land area suitable and available for emplacing guns and maneuvering tractors.
- b. Towing vessel with harbor or wharf not too far distant from firing point or camp.
- c. Proximity to railroad and storage facilities for ammunition which must be shipped so as to arrive ahead of the troops.
- d. Fair roads between railhead, camp site, and firing point.

Antiaircraft artillery also presents difficulties, as in addition to the large triangular field of fire required, airplane towing service must be

provided. A landing field is of course essential. In the past but little target practice has been engaged in by National Guard anti-aircraft regiments. The main difficulties have been a restricted field of fire and lack of towing planes. Past experience indicates that target practice will be most satisfactory when the following conditions obtain:

- a. Water area in close proximity to the camp over which the target can be towed with a contiguous and accessible land area, not over two miles from the camp, where the guns may be emplaced.
- b. A suitable landing field, accessible from the camp and within ten miles therefrom and connected therewith by telephones.
- c. Two airplanes to be stationed at the landing field during the entire encampment. Any type of airplane is suitable for the first week of the encampment but those available during the last week must be suitable and equipped for towing an aerial target.

The matter of the requirements for a successful training point for the use of heavy tractor and anti-aircraft artillery has been discussed in some detail for the reason that these requirements have not always been considered in the past. I wish to say that any officer detailed to select a camp site or training point should be conversant with the requirements of the arm and what it is intended to accomplish and should then engage in a mental rehearsal covering the entire period of the encampment, from the time the troops leave their home stations until they return thereto. Only in this way can the recurrence of past mistakes be avoided.

As might be expected the accomplishments of National Guard Coast Artillery during the period of the annual encampment are by no means uniform. A regiment should be able to go to camp, make and keep itself comfortable, emplace or prepare its guns, lay the necessary wire and establish communications and fire control stations, and engage in a successful target practice. Not all of the regiments were able to accomplish this last year, though in some cases this was due to factors over which the regimental commander had no control. However, progress is being made and will become more marked as the selection of training points is made with more care and the requirements are more generally understood.

The assistance given by officers and noncommissioned officers of the Regular Army during these encampments is of incalculable value. However, much depends upon the individual. At times, especially where a certain degree of personal skill is required, as in bore-sighting a gun, there is a tendency on the part of Regular Army personnel to perform these duties themselves instead of instructing the National Guard in the performance thereof. It is obvious that no training results from such action. It is far better instruction to require the National Guard to

perform the actual tasks themselves, even though mistakes may be made or a longer time taken in the performance thereof. It is further believed that often, especially when troops are trained at a post with a Regular Army garrison, too many instructors are provided. When an instructor or sergeant instructor is always standing by, there is a tendency on the part of the National Guard to ask for assistance in the adjustment of plotting boards and the like, rather than to make the attempt themselves. This assistance often develops into performance and as such has very little training value. No fixed rule can be laid down. It is obvious that a proper middle course must be followed which will result in the maximum of instruction for the National Guard combined with a reasonable accomplishment of finite results.

From what has been said it is evident that training camps are a large and important subject. Vast sums of money are annually expended in connection therewith, but the results achieved are not readily apparent to the public at large. An expenditure of the same amount of money on a memorial bridge or a waterway would be brought to the view of many millions through the medium of the Sunday newspapers. However, few of the metropolitan dailies ever mention the training camps and when they do it is only as a matter of local news. The public is, however, taking a wider interest in this matter and more rapid progress will be made when the children of the present trainees begin to attend training camps.

In conclusion it is desired to emphasize the part played in the training of the National Guard by Regular Army personnel in their duties as instructors. It is conceived to be the duty of the professional soldier to keep himself up to date, this involving much time and study, and to pass on to the citizen components of our Army the last word on military subjects in such a way as to be readily grasped. Obviously many fine points must be brushed aside and the short time available concentrated on the most important essentials. The performance of these duties by the Regular Army leaves little to be desired, and in a few more years we may expect the National Guard as a whole to be a truly dependable force.

# A Discussion of Sky and Coast Defense

MAJOR R. R. WELSHMER  
*Coast Artillery Corps*

[Honorable Mention Essay Competition 1925]

## FORWARD

A point which I feel safe in assuming no aviator has heretofore mentioned—defense by the air is no cheap thing, as seems to be the popular opinion. I have not the figures and I doubt if they exist, but I have a conviction they would not be pleasant to look upon.—*Commander John Rodgers, U. S. Navy, testifying before Aircraft Board, 1925.*

The American people undoubtedly desire an effective Navy, until navies are proved obsolete, and an adequate, effective Air Service. Practically, there are two ways of increasing the effectiveness of our Navy and our Air Forces. First, directly by increases in ships and aircraft. Second, indirectly by increasing certain auxiliary arms such as seacoast artillery and weapons used in ground defense against aircraft, since these auxiliaries contribute directly to the effectiveness of the Navy and Air Forces. The second method, which is discussed in the following pages, does not appear to be understood, yet it is comparatively inexpensive. Dollar for dollar, within certain well recognized limits, the Navy and Air Service will be rendered more effective by comprehensive but coordinated development of seacoast artillery and ground defense against aircraft (sky defense) than by expenditures on any other means of warfare. This principle is of great significance to the Tax Payer.

## MEANING OF ANTI-AIRCRAFT

It is apparent from current newspaper articles and editorials that the Army Antiaircraft Service is not understood. There is an almost universal public opinion which indicates a belief that the Antiaircraft Service is diametrically opposed to adequate development of the Air Services. In other words, the two services are considered to be rivals. This is not the case. Perhaps this belief originates in an unfortunate selection of the term designating that element of the Army charged with ground defense against aircraft as "Antiaircraft Artillery." A more descriptive term would have been something like "Aircraft Assistance Service," which name would convey some idea of the true mission of the "Antiaircraft Service"—Help for the Air Service. The two Ser-

vices are not rivals. Every development in efficiency of the Antiaircraft Service makes the Air Service more effective. Once this is understood it is to be hoped public sentiment, and in final analysis Congress, will demand the full development of the so called "Antiaircraft Service." It is sadly neglected now. More so than the Air Service, as is readily understood if one stops to think what it's all about. Let us remember that the Antiaircraft Service, "Sky Defense" if you will, is aimed at *hostile* airplanes, not our own; and with this in mind let us see just what is its true relation to our Air Service.

The Antiaircraft Service, including antiaircraft cannon, antiaircraft machine guns, balloon barrages, searchlights, and listening devices, bears the same relation to air squadrons that seacoast artillery does to naval squadrons. Seacoast artillery, to a great extent, relieves the Navy from assuming a defensive rôle in protecting our coasts and allows the Navy to perform its proper mission—offensive action against enemy ships. Similarly, the Antiaircraft Service, to a large extent, should relieve the Air Service from the necessity of assuming a defensive rôle in the protection of points which may be subject to air attack and should free the Air Service to pursue its primary mission—offensive action against the enemy. Naval officers are advocates of adequate seacoast artillery and realize its effectiveness in regard to which the seacoast artilleryman claims that "one gun on land is equal to one ship at sea." History justifies the claim. Naval officers know modern seacoast artillery is superior in range and power to any armament carried by ships, and realize that the defense of seacoast artillery from aerial attack is the simplest of all problems confronting the antiaircraft gunner, because he is called upon to defend only a restricted area, comparable to a battleship, from direct attack. There is no rivalry between the Seacoast Artillery and the Navy. There might be if seacoast artillery were called "Anti-Navy Artillery." Adequate Seacoast Artillery does not lessen the need for an adequate Navy, but the combination of Navy craft and seacoast artillery gives the most effective defense against hostile Naval attack. Naval officers realize this. Similarly, there should be no rivalry between the Air Service and the Antiaircraft Defense. Adequate Antiaircraft Defense does not lessen the need for adequate Air Service, but on the contrary, if both are fully developed the most effective defense against aircraft will result. And this is necessary because, as the Italians say:

No matter how strong, no matter how daring, no matter how aggressive our aviation Service may be, it can never prevent, throughout its whole territory, that of the enemy from executing its multifarious actions, even though on a reduced scale.—*Italian Antiaircraft Defense Bureau.*

## EFFECTIVENESS OF ANTI-AIRCRAFT (SKY) DEFENSE

Unfortunately there seems to be a quite general belief that anti-aircraft defense by means of cannon, machine guns, and searchlights, is ineffective and that the only defense against aircraft is aircraft. This belief is unjustified, as conclusively proved by war records. The war showed that "one French gun on land is as good as one Zeppelin in the air." That is, a Zeppelin must either not venture near an anti-aircraft cannon or invite certain destruction if it does. Few people know this. Fewer still realize the effectiveness of anti-aircraft defense against all aircraft—that, for example, during the World War 2198\* airplanes were destroyed by anti-aircraft cannon alone. Yet destruction is not the sole basis for judging effectiveness of ground defense against aircraft. Instead its effectiveness should be measured by its success in preventing or limiting enemy aerial operations. In other words, the efficiency of ground defense against aircraft is measured, not only in terms of planes destroyed, but by its ability to destroy the morale of the aviator, to turn him back, to force him to change his course and altitude, or to require him to fly so high he can not accomplish his mission, and at the same time to assist friendly aircraft in destroying or driving away the enemy.

## WAR RECORDS

The following French statistics are absolutely reliable:

- In 1914 and 1915—Very few airplanes brought down—no statistics.
- In 1916—60 airplanes brought down, proportion 1:11,000 shots.
- In 1917—120 airplanes brought down, proportion 1:10,000 shots.
- In 1918—220 airplanes brought down, proportion 1:7,000 shots.

The above figures represent the number of airplanes officially recognized by the French as having been brought down, but do not indicate the actual number brought down, *as only the Germans could tell that*. Let us examine the 1918 statistics more carefully. If, instead of considering all guns, we consider only anti-aircraft guns with the 1918 fire-control equipment and firing high-explosive shells, we find one plane destroyed for each three thousand two hundred twenty-seven shots. To get the full import of these statistics, let us compare them with those of artillery firing at objects on the ground. For example, let us try to get an idea of what the destruction of a French 75-mm. gun cost the Germans.

Number of 75-mm. guns destroyed by German artillery: about two thousand two hundred. The best French authorities estimate that the Germans fired not less than two hundred fifty million shells of all

\*These figures do not include planes destroyed by the British.

calibers during the war, and that of these approximately fifty million were directed at 75-mm. batteries. From these figures they conclude that at least twenty thousand rounds were fired to destroy one 75-mm. gun, that is, two to seven times more rounds than were fired to destroy one airplane. These twenty thousand rounds involved the wearing out or bursting of two or three tubes, so that the operation may be worked in regard to material: expenditure—two or three tubes and twenty thousand shells; gain—one gun. Also, war records show that, in present day warfare, to kill one man required sixty times his weight in metal scattered over the battlefield. Destruction of airplanes, destruction of guns, destruction of men—any kind of destruction is difficult. In war, the important thing is not to be sparing but to win, and destruction is not an end in itself but only a means to an end.

But to return to counterbattery actions—why did the German Artillery require so many shells to demolish guns? French regulations claim that eight hundred rounds from the 75-mm. are sufficient to destroy a battery. Careful adjustment is sufficient, such as is conducted by ground observers provided with good telescopes, when the objective can be plainly seen, and such as would doubtless be used by aerial observers if they could get to within a few hundred yards of their objective. And why do not the aerial observers always approach near the objective? Why do they remain, when making an adjustment, over their own lines and six to eight thousand yards from the objective? Why, if not for the antiaircraft defense system, which includes not only the antiaircraft cannon but everything that defends us against hostile airplanes,—pursuit planes, antiaircraft cannon, antiaircraft machine guns, and searchlights. This illustrates the greatest service rendered by the Antiaircraft Defense. It keeps the enemy airplanes under control. That is, it makes them keep away or invite destruction. This is work that is often negative, often not very glorious, though work of prime importance. But remember, like bills on the first of the month, the Antiaircraft Defense is always present. It protects the doughboy in the trench and on the march, it protects cities and industries, it protects seacoasts and the interior.

In the face of what has been accomplished in the acid test of war it can not be proved that ground defense against aircraft is ineffective. Here is a resume of World War accomplishment: Italy: planes brought down by aviation services on all fronts, five hundred forty; planes brought down by antiaircraft, one hundred twenty. Germany: aviators got six thousand five hundred fifty-four; antiaircraft, one thousand five hundred twenty. France: aviators accounted for two thousand; and antiaircraft fire, five hundred.\* The American Antiaircraft Service,

---

\*Official Italian Report.

although in action only four months, and having only two skeleton artillery battalions and two machine gun battalions in action, is officially credited with bringing down fifty-eight enemy planes; and the report of the Commander in Chief, American Expeditionary Forces, gives six hundred five as the average number of shots to bring down each plane. In the year 1918, a total of four hundred eighty-three German planes were dispatched to raid Paris, but only thirty-seven penetrated the antiaircraft defenses of Paris, and of these thirty-seven, thirteen were brought down by antiaircraft fire.

The recent statements of Major Newmann, German Air Force, are illuminating and are quoted as published in the *Army and Navy Journal*:

The German air officer stated that after the first air raids by German planes over England the increased efficiency of British antiaircraft guns to protect London made it necessary for German machines to fly at a height of at least 17,000 feet, and official orders were issued to that effect. Other information the major has given includes the following:

The first air raids over London, made by Zeppelins in 1915, were delivered at a height under 3000 feet, owing to the weakness of aerial defenses. In 1916 so effective had the antiaircraft defense become that the Germans suffered losses at 9000 feet.

Fighting squadrons of airplanes when organized were maneuvered as high as 15,000 or 18,000 feet.

Numerous disasters to German airplanes are noted by Major Newmann, when under orders the airmen flew over enemy battlefields in day time to make observations at a low altitude to get desired information.

Towards the end of 1917 the advisability of discontinuing patrol work over the main battle ground was seriously considered by the German high command, owing to the heavy casualties suffered by their planes through the very efficient aerial defenses of the Allies.

Single reconnaissance machines were constantly shot down while flying low on the British front about Cambrai.

#### RECENT ACCOMPLISHMENTS

The results of the war are conclusive, but improvement is to be expected in the future. The 1924 and 1925 target practice gives an indication of what may be expected:

Battery "E," 64th C. A. (A. A.): 30 shots at towed target, 8400 feet altitude, six hits in day practice; night practice, 4800 feet altitude, nine hits.

Battery "G," 64th C. A. (A. A.): altitude 7360, night practice at towed target, 10 hits.

Battery "B," 65th C. A. (A. A.): 41 shots and 15 hits.

Battery "B," 63d C. A. (A. A.): firing 591 rounds, shot down one target, shot the tail off another, put 56 holes in the targets, and scored

96 hits any one of which might have destroyed an airplane. All this with the target over a mile high, two miles away, and moving 80 miles per hour.

The above target practice results were obtained firing shrapnel with old fuzes and using a war-time material. The danger volume of this kind of projectile is approximately a sphere of fifty yards radius. With high explosives have a greater danger volume, and using improved fuzes fired from new high-muzzle-velocity guns, even better results are to be expected. When Congress makes funds available for quantity manufacture, new 3-inch guns having a muzzle velocity of twenty-six hundred foot seconds and a vertical range of twenty-five thousand feet will be supplied troops. Also a 105-mm. gun will be supplied which can fire to an effective vertical range of approximately thirty-five thousand feet. These conditions warrant the possibility of antiaircraft cannon attaining a degree of perfection comparable to seacoast artillery in destroying targets, and it should be remembered that modern antiaircraft cannon can fire in fog or darkness by means of sound location. It has been claimed that smoke screens laid by enemy airplanes will preclude antiaircraft fire and at the same time protect hostile ships from shore fire. This claim is not justified. The plane which lays a smoke screen is a vulnerable target for antiaircraft cannon and machine guns if within range; if not within range the smoke screen serves no useful purpose. Moreover, objectives in or behind a smoke screen may be fired upon with modern weapons by means of sound location just as they may be fired upon at night when illumination by searchlights is not available.

### MACHINE GUNS DEADLY

Antiaircraft machine gun fire is effective against low flying airplanes, especially those endeavoring to attack ground objectives. Convincing proof of this is to be found in the fact that Battery "E," 63d Coast Artillery, recently made 1000 hits on an aerial target in approximately thirty minutes firing time. However, erroneous conclusions as to the effectiveness of antiaircraft machine gun fire are quite generally prevalent. The following editorial appearing in a recent issue of a daily newspaper is quite typical:

Two Martin bombers towed targets about Fort Tilden, Rockaway Park, last week and machine gunners fired 16,000 rounds of ammunition at them. The targets were hit only nineteen times and that's an average of one hit for every 842 rounds fired. That test is proof enough for anyone that airplanes can't be repulsed by antiaircraft batteries. David brought Goliath down with one shot, but that happened a long time ago and isn't a parallel instance. We need more airplanes and ought to have them.

The editorial gives a misleading impression as to why more airplanes may be needed and the conclusions in regard to antiaircraft machine guns are erroneous because based upon faulty reasoning as to their effectiveness. Remember that the primary weapon of airplanes attacking airplanes is the machine gun. It is the same sort of gun as that used by the Antiaircraft Service. Attempts to mount more powerful weapons in attack planes have not been successful. The attacking airplane must maneuver while firing and the number of machine guns carried is very limited. This limits the volume of fire from each airplane, and the machine gun must be fired from a *rapidly moving* airplane at a *rapidly moving* airplane. Such is the problem of aerial gunnery. The records of accomplishments are not available, but, to a large extent, it is upon that accomplishment that advocates of airplanes only for defense against aircraft must rely to justify the stand taken in the above editorial. It would be interesting to see the actual figures of hits in aerial gunnery per rounds fired and compare them with the results obtained from antiaircraft machine guns fired from the ground. It is difficult to imagine that for the same ranges the comparison would be unfavorable to ground machine guns, which have the great advantage of being fired from a stable stationary platform. In addition, antiaircraft machine guns on the ground may be so grouped that the volume of fire is not from a few but as many as eight or even sixteen machine guns against a single target. In both aerial gunnery and antiaircraft gunnery the machine gun is a short-range weapon. Airplanes endeavoring to attack ground objects can do so only at low altitudes and short ranges, both well within the reach of antiaircraft machine guns. If such attack planes fly higher, they can do no damage to ground targets with their machine guns, and the hostile planes under these conditions are vulnerable targets for our own attack planes, our 37-mm. automatic guns, and our antiaircraft cannon.

Effectiveness of antiaircraft machine guns is not a question of the number of shots fired and hits obtained, as would be inferred from the editorial quoted, but is a question purely of the *time in which the hits were obtained*. Taking the above figures, a battery of antiaircraft machine guns fired eight hundred forty-two rounds and obtained one hit in twenty seconds. This number of hits is hardly an average. For example, Battery "E," 63d Coast Artillery (A. A.), in a recent antiaircraft machine gun target practice, when firing only four guns, made one hundred fifty-six hits. That was three hits each two seconds of firing time for a machine gun battery, and the hits were made with an ammunition expenditure of only twenty rounds per hit. But for the purpose of this paper the less favorable figures will be considered. Eight hundred forty-two rounds of machine gun ammunition costs

approximately fifty dollars. The plane which it damages or destroys costs from \$10,000 to \$25,000. Is that ineffective? Recall that the French War Records show that in present day warfare to kill one man requires sixty times his weight in metal scattered over the battlefield. In terms of machine gun ammunition that is approximately *one hundred sixty-one thousand rounds* of ammunition. In war all destruction is costly, but antiaircraft machine gun fire directed at air targets seems to be less costly than ground machine gun fire directed at enemy troops. We have then eight hundred forty-two rounds of antiaircraft machine gun ammunition damaging or destroying one plane of, say \$25,000 value and one, two, or three lives in twenty seconds at a cost of fifty dollars, as compared to ground action using one hundred sixty thousand rounds at a cost of \$8000 to destroy only one life. It is problematical as to how many such hits from a machine gun are required seriously to damage an airplane. One may do so, but it might take more. It would be cheap destruction if it took ten, twenty, or even a hundred.

#### NEW DEVELOPMENT

The present fifty-caliber antiaircraft machine gun has a vertical range of twelve thousand feet. It is fired at the rate of four hundred fifty shots per minute. The ammunition used is armor piercing and tracer, the tracers being effective to three thousand yards. These guns are being issued to troops for use. Meantime, a 37-mm. antiaircraft gun, which is in effect a large machine gun, has been developed, and when funds are available for quantity manufacture these will be supplied troops. The 37-mm. has a vertical range of fourteen thousand feet, fires one hundred twenty times per minute, and utilizes a high explosive shell provided with a fuze so sensitive that it explodes on contact with airplane fabric. The fifty-caliber machine gun and the 37-mm. automatic constitute the backbone of ground defense against low-flying aircraft attempting to observe, photograph, or attack our ground forces. The 3-inch and 105-mm. cannon are normally used against high-flying aircraft and especially large, slow-moving bombing planes.

#### THE PRINCIPLES OF WARFARE ARE UNCHANGED

Since the airplane has carried warfare into the sky, there is a more or less general opinion to the effect that the next war will be primarily aerial warfare, waged almost exclusively by airplanes both offensively and defensively. The soundness of such opinions is questionable. It is questioned by the most experienced of the military and naval experts, including many aviation experts. The best opinion seems to be that while the airplane has carried warfare into the sky, it is, after all, merely a new instrument of warfare, to be used to the greatest extent

offensively and defensively in connection with every other known element of warfare. Consistent with this idea, the best military thought urges coordinated development of all elements of the Army and Navy, including among such elements, the Infantry, the Field Artillery, Coast Defenses, Sky Defenses, the battleship, the airplane carrier, the submarine, and so on—all to be worked into a smooth running military machine. The Air Forces in any war now conceivable will have important missions, but they can not do it all. If they can, why does not France, with the most powerful air force in the world, wipe the lowly Riffs off the map? They have neither aircraft nor ground defense against aircraft.

In visualizing the part aircraft will play in any future war, let us remember the following past experiences and present conditions:

1. The Allies bombed the Zeebrugge Flood Gate for four years without hitting it.

2. The destruction of the battleships *Virginia* and *New Jersey* by bombers took hours. The ships were not maneuvered, were anchored, and were defended neither by friendly aircraft nor anti-aircraft guns.

3. For years the Germans tried to wreck the flood gate at Dunkirk by aerial bombs without success.

4. The cruiser *Goeben*, aground for a week, was bombed a thousand times, hit sixteen times, and then went on its way, good as new, to cruise the Black Sea.

5. Aircraft are too limited in radius to wage successful war on sea power. The radius of action is too limited to permit attack from overseas on our coasts. We have two mighty oceans protecting us from overseas attack, and this protection will exist so long as we control the seas.

6. In order to remedy fatal lack of radius of action airplanes are put on carriers, but there are limitations on the number of planes carriers can bring and limitations on carriers themselves. The Treaty of Washington limits our carrier capacity and also that of Great Britain, France, Japan, and Italy. Our capacity is equal to that of Great Britain and greater than that of Japan, insuring us a reasonable degree of security. Airplane carriers are ships of special design which are neither cheap nor can they be built over night. Moreover, being surface ships they have all the limitations of surface craft. If it be admitted that aircraft must be put on carriers to bring the planes against us or even that the planes must obtain fuel from surface ships, then with an inferior hostile fleet the planes are relegated to spasmodic raiding activities. It has been stated that aircraft can never be a substitute for sea power because it can not carry enough fuel to seek out and sink battleships anywhere on the high seas. Most people are inclined to visualize airplanes in contact with battleships or our frontiers

without considering how contact was gained. It will be wise to consider from what point did the airplane start, and then how did it get to that starting point unmolested. In this connection, if there be those who believe, for example, that air attack may be based on the shores of Alaska, let them remember that aircraft are as uncertain as the weather. When diphtheria antitoxin was to be sent some two hundred miles across icy Alaska it was not an unreliable airplane that carried relief but the most primitive motive power known to man, the sled dog. May we remark, without being ungracious, that in war it is essential that any primary element making for ultimate success must at least be certain—reliable.

7. Next to radius of action probably the most serious limitation of aircraft is weather. A commander cannot afford to place main reliance during sustained operations in a force such as aircraft which is not available at any time and under all circumstances. The airplane is not such a dependable weapon. Not only severe storms but even ordinary clouds and foggy conditions put it out of action. All know of frequent postponements of air maneuvers during times of peace, but they exist in time of war also and frequently so limit air activities that they are properly considered a special arm for special operations. The following extracts from Admiral Sir Reginold Bacon's *Dover Patrol* show up, in a striking manner, these defects during sustained operations:

Heavy gales and great quantities of rain were experienced during fourteen of the thirty-one days in December, 1915, and no flying was possible, while on others the conditions were such that while protective patrols were carried out over the warships off La Panne, it was not considered feasible to undertake offensive work. A break in the weather called a halt in the continuous bombing attacks on both sides during the first two weeks of February, 1917, and except for an occasional odd day, no flying operations were possible.

It will be noted that the period of inactivity here mentioned was sufficiently long to have permitted a hostile navy to have crossed the ocean and attacked our shores with every possibility of success if our sole or even main defense were aircraft. How easily adverse weather may prevent aircraft operations at a particular time is illustrated by a letter from the book of a British aviator:

August 26, 1915.

DEAR BUD:

What do you think of forty warships bombing Zeebrugge? We were all due out there, of course, some spotting and fighters to protect the spotters. As luck would have it the weather was dud—clouds at 1500 feet—with the result that no one got there except a solitary fighter, and he was rewarded by a scrap with a German seaplane.

HAROLD ROSHER.

8. The airplane is incapable of sustained action. It has "one shot in the locker" so to speak, and, generally speaking, is limited to raiding operations.

9. Aircraft operations failed to close the line of communications between England and France, although well within their radius of action.

10. Aircraft can not take and hold positions. Wars are won by taking one position after another, holding it, consolidating it with others, and moving on to the next. On land this force is the Infantry, on sea it is the battleship.

There is a dangerous tendency toward development of an Air Force at the sacrifice of other elements in our National Defense, particularly the Navy, Seacoast Defense, and Antiaircraft Defense. No one has yet suggested that the submarine is obsolete. Until it is, and so long as there is even a possibility of surface craft not being obsolete, seacoast artillery is not obsolete. By a proper combination of camouflage, barrage balloons and antiaircraft cannon, seacoast artillery can be given practically positive protection against aerial bombers. In this connection it should be noted that the Belgian Coast was dotted by German seacoast artillery. The many attempts to destroy this artillery by bombs were unsuccessful. Observers found evidence of bombing but no single battery destroyed thereby. It has been claimed by some that aircraft lessens the need for seacoast artillery in coast defense. This claim is unsound. The proper way to view the matter is that aircraft is merely an added auxiliary in coast defense which used properly in conjunction with the seacoast guns renders our coast defense more effective. Both aircraft and seacoast artillery are essential to coast defense—adequate, so stated by President Roosevelt, to permit the Navy to be free to operate "only after our Coast Defense is reasonably secure *and so recognized by the Country.*" The significance of the seacoast gun and the antiaircraft weapons seems to be lost sight of because they play their all important rôle in a passive way. But think of Gibraltar, Helgoland, London, and Paris in the World War.

In the beginning of this paper we compared antiaircraft defense to seacoast artillery. During the war German seacoast artillery did not destroy any battleships, and yet it played its part, since the Allied fleets *did not venture to come near it*. For example, that was the case of Helgoland in the World War, but it effectively protected the German naval bases and the Baltic at its rear. Some persons complain that the antiaircraft defense does not bring down enough airplanes. Let them lay in a supply of patience, remembering the seacoast artillery. When the Antiaircraft Service has attained the same degree of perfection as its elder brother, it may no longer bring down any airplanes at all, for airplanes will no longer venture near it.

Let us bear the comparison between aircraft defense and seacoast defense in mind, in considering President Roosevelt's grasp of the significance of seacoast defense in its relation to the Navy as given in 1906. In a special message to Congress he said:

The necessity for a complete and adequate system of Coast Defense is greater today than twenty years ago, for the increased wealth of the country offers more tempting inducements to attack, and a hostile fleet can reach our country in a much shorter period of time. The fact that we now have a Navy does not in any way diminish the importance of Coast Defenses; on the contrary that fact emphasizes their value and the necessity for their construction. It is an accepted naval maxim that a navy can be used to strategic advantage only when acting on the offensive and it can be free to so operate only after our Coast Defense is reasonably secure and so recognized by the country.

The principles stated by President Roosevelt in 1906 apply not only to the relation between seacoast artillery and the Navy today but similar principles are applicable to the relation between the Air Service and the Antiaircraft Service. It is hoped the public will awaken to these facts.

#### SEACOAST AND SKY DEFENSE NEGLECTED

The element of the Army charged with "Seacoast Defense" and "Sky Defense" is the *Coast Artillery Corps*. The first attack on our United States must come from the air, the sea, or both. In any case the great blow must be taken by the Coast Artillery Corps. It should be ready at the drop of the hat. It is not so ready today. The crying need is more Coast Artillery soldiers; the next requirement is new guns, machine guns, and searchlights for antiaircraft artillery. As to personnel, the situation today may be summarized as follows: The present strength of the Coast Artillery Corps is not now determined by legislation, but by the War Department. The Coast Artillery now has 12,000 authorized enlisted strength on the basis of a total Army enlisted strength of 125,000 men. Before the War (National Defense Act of 1916) the strength of the Coast Artillery Corps was fixed by law and was 19,000 out of a total Army strength of 87,800. In terms of percentage this means that there is now assigned the Coast Artillery Corps a percentage strength of 9.6%, whereas before the World War the Coast Artillery had a strength of 21.8%. The present Coast Artillery enlisted strength is actually 63.2% of the 1916 strength in spite of the fact that the enlisted strength of the Army is 153% of what it was in 1916. Moreover, with this reduced strength the Coast Artillery Corps has added to its responsibilities, the manning of railway and motorized seacoast artillery, and the development and manning of the Antiaircraft Service—duties that were not required when the number of authorized soldiers was much greater than now. This means that the Coast Artil-

lery Corps of the United States Army has reverted to the status that existed in 1898, when Boston went into hysteria at the imagined approach of the Spanish Fleet and the forts offered no protection.

It may be that seacoast artillery and the antiaircraft defense should not be in the Coast Artillery Corps of the Army. Perhaps seacoast artillery and coast defense should be under the Navy. The Navy realizes the direct contribution to its effectiveness obtained from adequate seacoast artillery, and it is reasonable to suppose that, if charged with responsibility for it, there would be sufficient personnel furnished to man the guns. Now there is but one fort from Chesapeake Bay to San Francisco that is garrisoned. Charleston is just as important to South Carolina and New Orleans to Louisiana as New York City is to New York. President Roosevelt's coast defense policies recognized these facts, the people of the country were safe and knew it. Today there is no such security, and if the people think there is they are fooling themselves. If it be expected that these unfortified cities will be protected by the Air Service alone, let us remember that at the crucial moment weather may prohibit the use of airplanes, or the planes may deliver their "one shot in the locker" without effect. To put dependency in aircraft alone is to rely on an uncertain instrument. The seacoast gun is always present and is above all capable of sustained action. But seacoast guns must be manned to be effective. There is not a fort in the United States that has a garrison sufficient to meet any emergency. In 1914 the forts guarding the great strategic centers like Puget Sound and the entrances to New York harbor were the most efficient in the world, *and so recognized.*

Perhaps the Antiaircraft Defense should not be in the Coast Artillery Corps of the Army, but in the Army Air Service to which it is a proper and very helpful auxiliary. Regardless of whether seacoast artillery may ultimately be under the Navy and whether antiaircraft defense may ultimately be under the Air Service of the Army, they should be given adequate armament with accessories and, above all, sufficient personnel; and right now that means sufficient personnel for the *Coast Artillery Corps* of the Army.

It is the opinion of the writer that both seacoast artillery and the antiaircraft defense are properly under the Coast Artillery Corps of the Army. To put seacoast artillery under the Navy would merely move the dividing line between the Army and Navy back a hundred yards or so from the shore. To put the Antiaircraft Defense under the Army Air Service at the present time probably would not be helpful, because, as yet, that Service does not realize the value of antiaircraft to its own efficiency. Moreover, sky defense artillery is essentially a gunnery problem. The Air Service is not a gunnery corps but the Coast

Artillery is. It is hoped that the numerous investigations now being made will consider not only the status of Air Service personnel but that of other branches of the Service, and that some action to correct the present deplorable condition in regard to seacoast artillery and anti-aircraft personnel will follow. The condition may be traced directly to the fact that when the present Army organization was prescribed the World War was still the predominant consideration. In that war Coast Artillery could be used to fire at German ammunition dumps. It did not have to defend our coasts. In the next war it may be different. The present policy in reference to coast defense attempts to skeletonize forts like infantry regiments are skeletonized. This can not be done successfully. A "caretaking detachment" in a coast fort is not a skeletonized unit that in emergency can be quickly expanded into a combat unit. Seacoast defense must ever be ready. The principle should be as in 1914. That is, the peace time strength of coast defense troops should be about one-half that required in war. That does not mean a large Coast Artillery Corps, but it does mean an effective one. The Chief of Coast Artillery asks for approximately 30,000 men and that number is exactly what was authorized in 1916. Considering that additional duties of anti-aircraft defense are assigned the Corps, it appears this is a modest number for the mission prescribed. The need for increased personnel in the Coast Artillery Corps has been presented to the Secretary of War by the Chief of Coast Artillery, in his annual reports, but there has as yet been no action taken. To whatever degree our Air Service and our Navy are being neglected, failure to provide adequate anti-aircraft and seacoast defense merely increases the degree of the neglect. The neglect means that an enemy under present conditions could only be defeated after he lands on our shores. We should be able to prevent a hostile foot from touching our soil. This can be done if we have adequate fixed and mobile seacoast artillery for use with other auxiliary arms. Remedial action is necessary, and should be forthcoming if seacoast artillery and anti-aircraft defense are at all effective.

That seacoast artillery is effective against Naval craft is quite generally admitted. Witness the Dardanelles. That anti-aircraft defense is at least not negligible was demonstrated during the World War. Recall the record of World War accomplishments. Anti-aircraft or "Sky Defense" is a new service. It is a development of the World War. When it has been in existence as long as airplanes now have been, it is reasonable to suppose the effectiveness of elements constituting sky defense will be increased to a marked degree. That aviators realize this is clearly indicated by the fact that the aviation arm of all countries is continuing, with diligence, studies and researches as to the possibility

of flying at greater altitudes, as to the possibility of extending continually the limits of photographic observation, as to long distance bombardment, as to protecting aircraft with armor, and as to concealing aircraft with artificial clouds.

Italy sizes up reasons for developing anti-aircraft defense very well.

Even if we are convinced that the first indispensable element in the fight against aircraft is the possession of a strong aviation service, it is not believed that this could be sufficient in itself to afford at all times and places an adequate protection against air attacks.

An aviation service, no matter how superior numerically, technically, and morally, to that of the enemy, will never be able, from the first day of the struggle, to prevent that of the enemy from accomplishing or attempting bombardments, from trying to accomplish its own missions. If it can prevent it in one sector, it cannot do so in another; if it succeeds in bombarding one field, other fields and other aircraft will remain intact.—*Italian Anti-aircraft Defense Bureau.*

In weighing the value of the opinion of the Italian Defense Bureau let the reader consider this: While a well known officer of the Air Service, U. S. Army, who is an extremist in advocating a Separate Air Service as a cure all for military endeavor, commanded and used apparently the biggest offensive air force ever under the command of one man in war, the enemy took advantage of the temporary absence from the home base of his squadrons to bombard our own doughboys. The tactical use made of the air squadrons was theoretically correct, but it worked out practically to be the old story of the cat away the mice will play—our own men suffered. So it may be in the future. Let us bear these things in mind and develop every defense against aircraft, not merely aircraft alone. No other country appears to be neglecting ground defense against aircraft as is the United States. Italy, France, England, Japan are developing their anti-aircraft or sky defense. We would do well to follow their example and, better, to take the lead. Now we are lagging behind. The cause is lack of appropriations. Funds have been insufficient to place in service even one new anti-aircraft cannon, and there is a woeful lack of personnel trained in anti-aircraft work. On the whole Pacific Coast there are only three hundred trained anti-aircraft soldiers, and very few anywhere else. No progress can be made under these conditions.

#### NEED FOR COORDINATED DEVELOPMENT

The people of this country undoubtedly want an effective Navy and Air Service, and this irrespective of whether there is a United Air Service or both Army and Navy Air Forces. Adequate appropriations are required for the Navy and Air Service. Adequate appropriations and suitable legislation are also required to permit the Coast Defenses

and the Antiaircraft Service to function. Coast defense is merely neglected. Insufficient soldiers to man existing armament makes our Coast Defenses the weakest they have been since 1906. They are far from being the Coast Defenses that we had in 1914 as a result of policy pursued by the Roosevelt and following administrations. They should be restored to their place in the sun. The Antiaircraft Service is in its infancy and needs merely a chance to develop its potential power. The public press seems to be urging an adequate Navy and increased aircraft, but at the same time ignoring seacoast defense and maintaining at least, a passive attitude toward development of antiaircraft or sky defense. If it is a fact that seacoast artillery means a more effective Navy, and antiaircraft means a more effective Air Service, it appears that the present attitude is not only inconsistent, but tends to prevent both the Navy and the Air Service receiving aid, and economically, too, which would contribute to making them effective in the manner urged by the press and desired by the public. The following recent statement by Commander John Rodgers, U. S. Navy, before the Aircraft Board is very significant:

Now last, but most important—a point which I feel safe in assuming no aviator has heretofore mentioned—defense by the air is no cheap thing, as seems to be the popular opinion. I have not the figures and I doubt if they exist, but I have a conviction they would not be pleasant to look upon.

Dollar for dollar, within certain well recognized limits, the Navy, the Air Service, and in fact, our whole National Defense will be rendered more effective by an adequate development of the Coast Artillery Corps, meaning coast and sky defense, than by expenditures on any other auxiliary means of warfare. The cost of two battleships would modernize our Coast Defenses; the cost of two dozen airplanes is more than has been spent on Antiaircraft (Sky) Defense since the World War.

#### ADEQUATE NATIONAL DEFENSE THE RESULT

It is to be presumed that the negative attitude toward seacoast and antiaircraft defense will be reversed as soon as it is realized that our seacoast artillery, "Coast Defense," is directed at enemy vessels, not our own; that our own Antiaircraft Artillery—"Sky Defense"—is directed at enemy aircraft, not our own; *and that neither are rivals of the Navy or Air Service, but instead are their indispensable helpmates.* Adequate National Defense demands coordinated development of all elements of the Army and Navy, and not the development only of one at the expense of the others. Numbered among many elements essential to National Defense are the Seacoast Artillery and the Antiaircraft Service. They should both be sufficient and ready to receive that first blow from the sea, the air, or both when the bell rings.

# The Reserve Officers' Training Corps

MAJOR P. H. HERMAN

*Coast Artillery Corps*

THE Reserve Officers' Training Corps is an organization which has been established in civil educational institutions of the United States in accordance with the provisions of the National Defense Act of June, 1916. It is organized into two main divisions: namely, the Senior Division and the Junior Division. The Senior Division comprises those units that are established in educational institutions which grant degrees and in a few specially selected, essentially military, schools which do not grant degrees. The Junior Division comprises all other units. It includes those units established in high schools, essentially military schools, and certain other schools.

There are one hundred and thirty-two senior R. O. T. C. units established in our country. Each unit consists of one or more sub-units of branches of the service. For each of the sub-units, there are one or more officers of that branch of the service detailed for duty with it, the senior officer present being in charge. He is responsible to the P. M. S. & T. for the preparation and carrying on of a schedule of instruction for that unit. The other officers of his same branch of the service are his assistants. If the P. M. S. & T. so desires and it can be arranged without interfering with the instruction in any sub-unit, officers of one branch of the service may be used for the instruction in other branches.

The Senior Officer present for duty at an institution is known as the P. M. S. & T.; the other officers being designated as Assistant P. M. S. & T.'s.

In addition to the officers who are present at an institution, there are a number of enlisted men, mostly noncommissioned officers, on duty. These men are usually excellent men and, in some institutions, are carried on the college records with the rank of Instructor.

On the staff of the Corps Area Commander, and stationed at his headquarters, is an officer designated as Officer in charge of R. O. T. C. affairs. He represents the Corps Area Commander at the different institutions which are located within the limits of his Corps Area, coordinates the work within the area, is the immediate commanding officer of all P. M. S. & T.'s in the Corps Area, and makes all of the annual inspections.

In the offices of the Chiefs of the various branches, the officer in charge of training handles all matters pertaining to R. O. T. C. that require the action of the Chief. Such matters include application of institutions for the establishment of units, preparation of schedules of instruction, and the allotment to the institutions of certain articles of equipment.

It was recognized in the late war, that the proper place for a college graduate in our armies is that of a commissioned officer. It is often very desirable to have educated men in positions other than in the commissioned personnel; such men can be obtained from our specialists schools which is the purpose for which they are established. Any graduate of a college can, with a small amount of military training, perform the duties of a commissioned officer of the lower grades in time of war. The R. O. T. C. takes advantage of this fact and provides that training to the student. It gives this training along with his regular college work, so that, when he leaves the college trained to take his place in the business or professional world, he is also trained and ready, in the event of need for national defense, to take his proper place in the ranks of the defenders.

The primary object of the R. O. T. C. may then be stated to be to produce trained officers for the Officers' Reserve Corps, or, failing in this, to give to college students military training which will be of considerable value to the Nation in time of an emergency. Many of those students who fail to complete their college course and receive a diploma can be qualified for a commission with but a little additional intensive training.

Although the R. O. T. C. is not really a component of the Army, it is very closely allied to it. Provision for the use of the R. O. T. C. is made in Corps Area mobilization plans to the same extent as for that of components of the Army. In the event of an emergency, all R. O. T. C. students who have completed more than three-fourths of the entire course, will be offered commissions immediately; for those who have completed less than three-fourths but more than one-half of the entire course, training camps are to be provided for the completion of their training, commissions being offered to those successful. All other R. O. T. C. members will be given an opportunity to attend a training camp of longer duration, which will lead to a commission for those who can qualify; for those failing to qualify who complete the course, non-commissioned warrants will be offered. In this way, the government will utilize all of the training which has been given.

The course of instruction in the R. O. T. C. units established in our colleges, is divided into two parts; namely, Basic and Advanced.

The Basic part usually is made compulsory by the colleges. This is done almost of necessity, as one of the conditions under which a unit is established in an institution provides for a minimum enrollment in the unit. This number is, for Infantry, Cavalry, Field Artillery, and Coast Artillery, one hundred physically fit male students who are citizens of the United States. For other branches of the service, the minimum enrollment is fifty.

The Advanced part is voluntary. Only those students who have completed the Basic work, or its equivalent, and who have been recommended for further training are eligible. Those desiring to take it execute a written agreement with the Government to complete the course, including attendance at one summer training camp of not less than six weeks duration, providing they do not leave the college prior to graduation. The Government furnishes the uniforms and equipment necessary to carry on the military instruction. The Advanced students, in addition, receive an amount of money which is equivalent to the value of one ration per day.

The subjects of instruction which are taught are those which are prescribed by the different Chiefs of Branches of Service. This is so for the very good reason that it is highly desirable to have a uniform course of instruction given. Conditions being so very different at each college, it is not possible to prescribe a course which can be followed to the letter by all of the units. It becomes, then, the duty of the P. M. S. & T. to draw up a schedule, based on those which are prescribed by the Chiefs of Branches, which will fit his particular case. The Military courses must be of the same standard as the other courses given in the college. They must be conducted in a similar manner, in accordance with the rules and regulations of the college.

The work is both theoretical and practical. It is the experience of those who have been on R. O. T. C. work that practical instruction is much to be preferred whenever it is possible to give it. In some institutions, credit hours are given which are based on the number of lecture and laboratory periods given. The practical work done in the military course is considered as laboratory work. In some institutions, which are situated near an army post, arrangements can sometimes be made with the commanding officer of that post to put on a demonstration of one kind or another for the benefit of the students. In such cases, the students are taken to witness these demonstrations in a similar manner as they would make a shop visit.

The Basic course is given during the freshman and sophomore years. It consists of elementary subjects which form a basis for any advanced work to be given later. It is well, whenever the conditions of the college will permit it, to begin the military course with Infantry

Drill and Military Courtesy. It is most desirable to have the students in a military frame of mind before attempting to teach them military subjects. Nothing can accomplish this purpose so well as Infantry Drill. The Infantry Drill instruction should be short, snappy, interesting, and progressive.

College students object to infantry drill for the reason that it is usually monotonous, uninteresting, and more in the nature of punishment than of instruction. They should be made to understand that it teaches them self reliance, gives them a presence before other students, corrects any tendency they may have to stoop or otherwise hold themselves improperly, teaches them the value of discipline and to respect authority. There is usually but a short time available for drill instruction on account of climatic conditions and the time needed to instruct in the other prescribed subjects. In the college where I was P. M. S. & T., a student was made a well-drilled private in about twenty hours of actual drilling; a noncommissioned officer qualified as an instructor in another twenty hours; and after an additional twenty hours' experience, he was able to enter the commissioned officers' class and to perform the duties of a commissioned officer in the cadet corps.

Supplementing the training in Infantry Drill, lectures on military courtesy should be given. In this course the student's pride should be appealed to. He should be told of the advantages of military training, the reasons for and the results obtained by observing military courtesy in the Regular Army. He should be made to feel that the R. O. T. C. is a part of the Army of the United States and that his actions while in uniform will therefore reflect on the reputation of the Army as well as on that of his college. When properly handled, it is very gratifying to see how quickly students will respond to military training.

An idea of the subjects given can best be obtained by mentioning those pertaining only to members of the C. A. C. unit. These are, besides Infantry Drill, during the freshman year, Elementary Gunners' Instruction, lectures in Military Policy and History, and instruction and practice in rifle shooting. During the sophomore year, Gunners' Instruction is continued, the first part of Artillery Materiel taken up, lectures are given on various campaigns, and practical artillery drill is conducted on the cannon which are on hand for that purpose.

The Advanced course, given during the junior and senior years, includes, for the C. A. C. unit, Artillery Materiel, Motor Transportation, Field Engineering, Orientation, Gunnery, Military Law, and Employment of Artillery. In all courses, leadership training is emphasized.

The Advanced course training is followed by six weeks of training in a training camp at a Regular Army post. At this camp the student

sees and uses the materiel in which he has been instructed. comes into contact with students from other colleges, and absorbs the military spirit which comes from being present on an army post with its military surroundings. The value of these camps is well worth all of the time and money spent on them.

At the college to which I was assigned, the conditions were such that the students could not attend camp until after their graduation, instead of after their junior year as is prescribed. All of these students, therefore, received their commissions while at the camp. The impression made on them by receiving their commissions while in the military surroundings, and usually from the hands of some high-ranking officer, as well as on the under-graduates when these newly commissioned officers returned to the University to receive their diplomas, was a very deep one. In my opinion, it would be a distinct advantage if this practice could be made universal.

Officers assigned to duty with the R. O. T. C. at colleges take their places on the college faculties the same as the teachers in the other departments. The senior officer present is the Professor of Military Science and Tactics and the other officers on duty with him are assistant professors. These officers have the same responsibilities in regard to their department as the other faculty members have in regard to their departments. They attend faculty meetings and may be assigned committee work dealing with problems of a purely academic character. Their principal duties naturally are instructing. In some colleges all of the theoretical work must be given in lecture form with no preparation on the part of the student outside of the class room. Preparation of one or more lectures of this kind to be given every day requires considerable time. They must be interesting as well as informative.

Officers must always remember that the military instruction in colleges is secondary instruction as far as the student is concerned. It must not take his time away from his work which is the principle objective of the student. The course of instruction includes quizzes, examinations, and recitations, which entails the giving of grades and the keeping of records.

The P. M. S. & T. arranges the schedules of each branch unit, assigns subjects to the instructors, and supervises the conduct of all classes. He is responsible not only to the head of the institution for the manner in which the different subjects are handled, but also to the chiefs of the branches of the service. The personality, energy, and interest of the P. M. S. & T. will have more effect on the character of his unit than will be the case in most other lines of work. It is therefore essential that the proper type of officer be selected for this work. There must be harmony amongst the members of the military detach-

ment. Efficiency, team work, and discipline are expected from military persons by civilians; especial emphasis must be placed on these things.

There should always be a friendly spirit shown towards members of the college faculty, and cooperation with them in furthering the aims of their institution should never be neglected. It is well to show an interest in all college activities, taking the lead wherever possible. Close relations should be built up between the military department and the faculty and students. It is essential to have their confidence in order to have their aid in carrying on your work.

Students look upon the army officer in a different way from what they do the other instructors. There exists a much closer relationship, and officers will find themselves called upon to listen to and give advice upon many personal problems which are most vital to the student. No opportunity to be of the greatest possible service should be overlooked at these times, because they are opportunities to make an everlasting impression on the mind of the student in regard to his estimate of the value of military training.

Another important duty an officer on R. O. T. C. work must perform is publicity. This, I believe, is his *most* important duty. Of course, a good, interesting, worthwhile course of instruction will give the military department much publicity; but there are many other opportunities to obtain valuable publicity and none should be neglected. To give some idea of the vastness of this problem, I will mention some of the things done at the college where I was on duty in order to gain publicity and keep military training constantly before the students:

1. A good course of instruction.
2. A well drilled corps of cadets, with frequent ceremonies.
3. An excellent R. O. T. C. band.
4. A cadet staff which governed all R. O. T. C. activities.
5. Publication of an R. O. T. C. paper.
6. Excellent rifle and pistol teams.
7. An annual sham battle on graduation day.
8. Sparing no efforts to make the Military Ball the most important event of the college year.
9. Intensifying training in courtesy and leadership, making the R. O. T. C. student more prominent in his actions than other students.
10. Obtaining appointments to West Point annually for a member of the Basic course.
11. Supporting and giving prominence to the activities of the Scabbard and Blade, the honorary military fraternity.
12. Inserting articles in newspapers and making speeches over the radio.
13. Obtaining reserve commissions for eligible faculty members.
14. Arranging for demonstrations and exhibitions at the nearby army post.

The R. O. T. C. is now firmly established in many of our best educational institutions, and the output of reserve officers from them is steadily increasing. It is extremely unfortunate that at this time there should be a reduction made in the appropriation necessary to carry on the R. O. T. C. work. The natural growth of the advanced course has been interfered with so that the time when the output of reserve officers to the Officers' Reserve Corps will equal or exceed the loss of officers therein must be deferred.

The preachings of the pacifists and the Communists are constant problems to be dealt with. Reference to these things should frequently be made during the training of students and the fallacy of their arguments explained to them. No apprehension on this account need be felt if the matter is constantly considered and proper steps taken to handle it. That the R. O. T. C. has proven its worth and is now an important part of the educational scheme of the institutions where it is established, is shown by the words of Dean Schneider, of the College of Engineering and Commerce of the University of Cincinnati: "All engineers should receive military training on account of the great number of qualifications that are common to each of these professions;" and again, "Those young men who are not willing to prepare themselves to take their proper places in the defense of their country in time of need are not worth educating."

I am unalterably opposed to such suggestions as having only infantry in the National Guard, as has been proposed from some sources, as that would make the National Guard useless until artillery could be trained and its effectiveness in any war delayed by approximately a year.—*John W. Weeks.*

# The Organized Reserve

MAJOR S. F. HAWKINS  
*Coast Artillery Corps*

THE Organized Reserve is a new institution. It is a component of the Army of the United States which is destined to play a very large part in the event of a national emergency. It is therefore important that all officers become familiar to a certain extent with its composition, possibilities, and problems. Let us summarize briefly what the Reserve comprizes. First we have twenty-seven Infantry divisions allocated three to each Corps Area, six Cavalry divisions located in those Corps Areas deemed most likely to furnish cavalry troops, and the Corps, Army and G. H. Q. troops to complete six field armies.

The Coast Artillery Reserve consists of—

- 10 Brigades
  - 44 Antiaircraft Regiments
  - 15 Harbor Defense Regiments
  - 4 Railway Artillery Regiments
  - 3 Heavy Tractor Regiments
- Several separately numbered Battalions and Batteries.

Each of the Infantry divisions has a certain territory apportioned to it from which to draw its peace time cadre and, also, from which in time of war the draft should furnish the men necessary to complete the division. Within the divisional area the same principle applies. Each regiment has its own area and each company its particular share of the regimental area. Here, of course, is evident one of the first difficulties in organization. One company area will contain many officers; another, few or none. This may be solved to some extent by allocating the machine-gun companies to the entire battalion areas and the Howitzer and Headquarter companies to the entire regimental area.

The Field Artillery regiments are superimposed on the divisional area in the same way. Territory has been saved for a 155-mm. Howitzer Regiment should one be authorized. Medical, Engineer, Air Service, and Special Troops each have their own space, but the boundaries are of necessity somewhat elastic.

Each unit down to and including the company has a designated headquarters. This is usually the office or home of the commanding officer. It must always be remembered that a Reserve unit is a skeletonized organization consisting of the officers and not over ten per

cent of the key enlisted men as given in the war-strength tables of organization.

The mission of the Organized Reserve was well stated in a letter of last June from the Adjutant General's office. The Peace Mission: To develop unit cadres trained to receive, organize, supply, and train the selective service men necessary to bring the units to war strength during mobilization for a major emergency. War Mission: To complete the organization of those reserve units required to form six field armies under the basic plan for meeting a major emergency. It also states, "The Officers' Reserve Corps is maintained as a general replacement pool in which reserve officers are initially appointed and made available for assignment to the Regular Army, National Guard, and Organized Reserve."

In carrying out the Peace Mission an important step has been taken—the construction of mobilization plans. In the Reserve, Mobilization will mean that the rendezvous of each company is its own home town. This, at the same time, presents decided advantages and serious difficulties. It will be unnecessary to await the construction of expensive cantonments, as an empty building can be secured locally; a restaurant will provide meals until mess equipment is received. No draftee need lack blankets or clothing, as unavoidably happened in 1917, since all will be close to home sources. On the other hand, administration and supply will be difficult. A regimental commander will find his unit scattered over a considerable area with young and perhaps entirely inexperienced company commanders. Quartermaster, Ordnance, and Medical supplies will have to be shipped in many small shipments to many places. (Local transportation and numerous other matters must be provided for.) To meet the situation we have the unit mobilization plan. These have generally been prepared with the help of the Regular Army executive and will be found to be much alike in any one regiment. But each commander and his subordinates have been made to visualize his particular problem and its solution. In this respect we are far ahead of 1917.

The subject of instruction and training is and doubtless always will be the big problem with the Reserve. Much has been learned in the last four years through the efforts of the Regular Army and the hearty co-operation of Reserve Officers. At first the fifteen-day training was in Divisional camps. Instruction was almost entirely theoretical and didactic and was given by capable teams from Fort Leavenworth and Fort Benning. Some practical work was given in marksmanship and equitation.

As time progresses much greater emphasis is placed on unit training. The War Department has enunciated the policy that the unit commander must understand his responsibility and exercise his authority

on both active and inactive duty status so as to develop an organization with a unit entity of which it is conscious at all times. Accordingly, during the past summer, regimental training camps under command of Reserve Officers were the rule. Much of the instruction was given by Reserve Officers.

In most Corps Areas a Reserve regiment assisted for fifteen days at the opening of the Citizens' Military Training Camps. This is a most excellent form of training, as it approximates closely the duty required in case of a major emergency. The regiment so detailed should be informed well in advance and given instruction in close order drill, saber drill, etc.

The problem of inactive duty training is difficult. Some months ago the War Department appointed a board to study the whole subject. It held a number of meetings and conferences and gave much consideration to the matter. Recently the board was dissolved without, apparently, having arrived at any definite conclusions. It would seem necessary that the War Department first determine the minimum amount and kind of training to keep an officer reasonably proficient in his grade and qualify him for promotion,—what should be given on active and what on inactive duty. Four hours work a month has been considered.

Much has been learned about Correspondence schools. The average Army officer will be surprised by the number who enroll and the amount of work done on these courses. Many drop out, but no more than in civilian schools where the courses are paid for.

A simple method of procuring texts is yet to be evolved. It is most exasperating to the student to sit down to work some winter evening and find that he must send to Leavenworth ten cents for a map, to Fort Benning ten cents for a chart, etc. He believes that if he is willing to donate his time he should be relieved of the bother of sending three or four letters for texts.

The third division of this subject is duties and problems of the Regular Army officer on duty with the Organized Reserve. Fortunately ~~the duties~~ are nearly all pleasant and the problems worth solving. The first essential is to believe in the Reserve. This should not be difficult if one thinks the matter through. The National Defense Act gives us the first real defense policy which we have ever had. The success or failure of this policy rests largely on the Reserve. If this plan is consummated we have a practically complete organization—the overhead for twenty-seven divisions, with Corps and Army troops. All of this personnel would have some training; many, actual war experience. This scheme may not be as good as the Swiss system or some other system, but it is certainly incumbent on the Regular Army officer to get the best out of it and to work for the improvements he deems necessary.

The spirit of the Reserve officer is excellent. He has little to gain politically or financially by being in the Reserve and is there chiefly because he is a patriotic American citizen interested in the military game. It is therefore a pleasure to work with him.

One of the first problems is a place to live. This is important because it affects appreciably the value of the officer to the government as well as his enjoyment of the detail. Select a location where you will be content to remain for the four years. You may then form local contacts, take a part in the life of the community, become known as representative of the service, and form many pleasant friendships. Some officers move from place to place and do not become acquainted anywhere. In small towns the commutation furnished is adequate; in large cities, hardly sufficient.

Professional duties vary, largely, as to whether you are at headquarters or a separate station. If at a new station it will be necessary to find an office in some armory, postoffice, or other public building, as generally no funds are available for renting.

A second essential on this duty is to endeavor to satisfy every demand made upon you. In common parlance; "Never pass the buck." To illustrate what is meant: You are busy marking papers or working out mobilization plans; some one comes in and asks a question; perhaps he does not belong to your division; you are not interested in him. Do not yield to the temptation to tell him to write to the A. G. O. or Corps Area, though that might be the plausible thing to do. He has taken his time to come to your office; you are being paid to further the one Army plan in any way possible. By a few minutes work you may find the data; telephone a nearby office for it or dictate a letter which will procure it. In any case you will have secured a friend for the Reserve if you have made an honest effort, and, incidentally, you will have saved headquarters extra correspondence.

Every Reserve headquarters should have a good stenographer. If you do not have one, a likely youngster will pick it up in a comparatively short time if you dictate slowly at first.

Division and other headquarters publish bulletins from time to time. Experience suggests that these should not be too frequent nor too long. Otherwise it arouses criticism and goes with the oil circulars to fill the waste basket.

When reply is desired, the questions and answer form, with addressed franked envelope, is sent out. Great care must be exercised in wording these questions. It was found that even after several officers had checked a form it was misinterpreted.

Every chance must be taken and opportunities made to come in touch with Reserve personnel. Only thus can interest be maintained.

Divisional and regimental dinners do much to develop *esprit de corps* and morale,—one or two each winter, well arranged and with good speakers. Shooting clubs and riding classes have helped where facilities are available.

The headquarters automobile is a valuable asset and a regimental executive will find that a trip or two over his area each year creates more interest than dozens of letters. Arrangements have now been made whereby an officer can be reimbursed for gasoline and oil used in his private car if the trip is properly authorized.

Where officers can be gotten together, one or two night classes a month for instruction have been found successful. This is particularly true if there is some definite objective to train for such as a C. M. T. C. or contact camp with the Regular Army.

It will be found beneficial on this duty to join such societies and organizations as your inclinations and finances permit. Lodges, Rotary clubs, Kiwanis, Neighborhood clubs, golf and tennis clubs, and, of course, the Military Order of the World War and the Legion in some places. There will be frequent opportunities to speak or otherwise assist. Many clubs give Army officers preferred rates or omit initiation fees.

Every endeavor should be made to maintain cordial relations with the National Guard. The two are not competitive. Applicants should always be advised to join the Guard if they have the time.

A subject which will give considerable food for thought is promotion. This was formerly by oral examination before a board of officers and promotion was quite rapid. At present a certificate of capacity is necessary and requirements are more stringent. The difficulty is that the best type of officer cannot afford to take time from his business and the more mediocre will frequently get the advancement. This matter of promotion has been a source of jealousy with the National Guard in some sections as officers drilling every week see those in the Reserve outstrip them in rank, which rank would, of course, be held in case of war. This condition has been remedied somewhat by the new regulations. If an applicant for appointment or promotion must be turned down the case should be handled as tactfully as possible. If he shows ability he should be advised to take Correspondence Courses or otherwise prepare himself for re-examination.

As may be perceived from the foregoing the activities of an officer with the Reserve are very largely dependent on his own initiative. They are not prescribed. He may do much or little. The interest he manifests will be reflected in the size, enthusiasm, and quality of his organization. The Reserve detail is an opportunity for service, to enrich one's knowledge of human nature, to broaden one's outlook, and to come into closer contact with the outside world which we are prone to forget.

# French Coast Defenses

COLONEL G. DUMONTET

*French Artillery*

[Extracts translated from the *Revue d'Artillerie* by  
1st Lieut A. J. Maxfield, C. A. Res.]

## SEA COASTS—PARTICULAR CHARACTER OF THEIR DEFENSE

ON land, the limit of an army's protection can never go beyond the military frontier. On the sea, however, this is not so. The defense of a coast does not stop on the coast—it must be established beyond this. It must even extend beyond the limit of territorial waters, and meet and cooperate with its high sea forces. If these last measures are retained or called to another theatre of operations, the defense must remain on the high seas, provided the submarine chasers, planes and submarines at the disposal of the coast defense commander for his defense permit such procedure.

Because of its military ports and navy yards the coast becomes the base of operations for the fleet. By the same token, because of its commercial ports, it becomes the base of supplies for the territorial armies. During the World War the ports of France received, and then transported to the Western front, millions of men and innumerable tons of materiel.

In modern war it no longer suffices, as in the past, to insure the lines of communication of an army with its base of supplies. Today, the immense needs of armies demand communication with the world. Our maritime routes must be protected by our squadrons or those of our allies. The economic life of a country and the rationing of armies depend entirely on the seaports, and these, in order to be free to operate, are in turn dependent on adequate coast defenses.

The protection given the coast by the fleet and its auxiliaries and aerial forces cannot be regular or impassable. The coast will be subject to attacks, more or less severe, from the enemy fleet, depending on who controls the sea. But these adverse enterprises do not menace to the same degree the various parts of the coasts.

Suppose the enemy desires to destroy the fleet supply bases, to cut all coastal communications, and to attack war production shops and rationing points. Then his principal objectives will be the military ports, navy yards, shipbuilding plants, and other industries such as railroads, viaducts, etc., easily accessible from the coast. In the

event that he wishes to operate massive disembarkments having a definite strategical object in view, or to land small raiding parties charged with destroying the organization of the defense and other works, the weak points make themselves known through the landing facilities offered and the importance of the objectives opened up to the enemy.

The coast line then presents an easily defined and limited number of vulnerable regions where the defender can group his forces and prepare his fields of battle with forethought as to the coming operations. It is in these regions of our sea coast that we must reorganize our coast artillery armament, by giving to it new batteries with powerful and modern engines of destruction capable of engaging efficiently the fire of the naval enemy and that of its air forces. Also, in these regions it will be wise to see that land forces are placed at the disposition of the coast defense commanders; under certain conditions these troops may be greatly reduced. It is then that mobility will supplant numbers.

The troops assigned to coast defenses are called upon to play the rôle of covering troops, their mission being to prevent surprise attacks upon vital points and to hold up outflanking landing parties until such time as re-enforcements arrive.

An echeloned network of defense the length of the coast, advance posts distributed through the zones particularly menaced, reserves established in proximity to the principal communication centers, and efficient disposition of means of transport, will permit coast defense commanders to bring to the attacked points sufficient forces to effect a victory.

But if the assailant is resolute, master of the sea, and has powerful means, the task of the defender becomes a formidable one. He will be unable to fulfill his mission of "covering," *i. e.*, to hold out for the time being, if he has not carefully studied in advance the fields of battle he may be called on to defend, and if he has not previously organized and equipped these centers as fully as possible. The rôle of the coast defense commander is most important, not only from a naval standpoint but also in view of the military operations he may be called on to prepare and direct.

#### HISTORICAL SKETCH OF OUR COAST DEFENSES

From time immemorial, France by reason of her extensive coasts, has always been exposed to landings. The fleets of the past being at the mercy of the winds, not much reliance could be placed on maritime means to insure the safety of the coast. It was therefore necessary to distribute land forces along the coast to repulse any attempted invasion—this at a time when armament was weak and communication difficult. But the regular forces were often called to defend the terrestrial border. It thus became necessary to confide the defense of the coast to

coast guard militia especially reserved for this mission. This militia was recruited in a coastal zone, six miles wide, that was exempt from furnishing men to other territorial militias. In times of peace, their service consisted of two musters or inspections per year (Charter of 1716). In the beginning, they were commanded by the "Admiral of France." Later they were placed under the command of provincial governors, who received their orders from both the Army and Navy.

The defense of the coast was completed with the distribution of coast batteries. A certain number of them, armed by the Navy, avoided the authority of the provincial commanders. In times of war, it was often necessary to re-enforce the poorly-trained coast guard militia with regular troops dependent on the Minister of War. This non-homogenous gathering soon began to feel the effects of the duality of command (Army and Navy) to which it was subjected, which proved inconvenient many times later on. Unity of command was necessary. Under pressure of events, this unity of command was created for the first time in 1695, at Brest, when Louis XIV charged Vauban with the defense of the port against the English; a second time in 1755, when Louis XV on the eve of the Seven Years' War gave the Marshal of Belle-Isle the command-in-general of the coasts of La Manche and of l'Océan. The Marshal commandeered rifles, organized coast guard companies into battalions, battalions into regiments, and sent them into camp for instruction; he garrisoned the permanent fortifications and assigned reserves and patrols to them. The most important points were held by regular troops which were replaced by contingents from the interior. Coast guard dragoons and companies of cannoneers were created. The coast guard units were under the command of the Navy. But the rôle of the regular army troops became more and more important in the defense of the coast, and in 1759 the defense of the coast reverted to the War Department.

In 1775, the Navy took over anew the batteries of the coast and obtained those of Brest in 1776 and those of Rochfort in 1779.

In 1778, an ordinance (complemented by that of 1780) instituted companies of coast guard cannoneers and "watch" companies, the latter formed of men subject to service in the coast guard and not incorporated in the companies of coast guard cannoneers. These "watch" companies were officered by the Royal Artillery Corps, attached to the artillery districts and inspected by general officers of the Army, although still under the authority of the Admiral of France and under the orders of the provincial commanders.

Thus stood the defense of the coast when the Revolution broke out.

The war with England during the Revolution was destined to add new importance to the defense of the coast. The Revolution surpassed

the militia and coast guard cannoneers and replaced them with national guards from maritime departments. By the law of July 10, 1791, the National Assembly returned the defense of the coast to the War Department. This law is still in force at the present time. It was designed for the conservation and upkeep of the fortifications and the classification of their mission in war. It declared "National property" all military posts and the land on which they stood, whether they were on the coast line or the terrestrial border, and confined it all to the War Department.

After the fall of Toulon, Bonaparte was charged with the bringing to a state of defense the coast from Marseilles to Menton. Under the Consulate, this defense was reorganized and reenforced. The coast of La Manche was strongly armed, and in 1803 became the "iron coast."

After Trafalgar, it was thought that a mobile active force, based entirely on the means afforded by the War Department, would solve the problem. Detachments of all arms were established in camps near the coast, with strong reserves in all large ports. In 1808, the Emperor built coast fortresses, manned by the élite of the Army. In 1810 the development of the coast defenses had reached a high stage; and at that time there were 900 batteries, 3600 cannon, and 13,000 cannoneers.

Mobile columns were formed, each column comprising 1000 to 1500 infantrymen, 200 cavalrymen, and two field guns. Like all Napoleonic conceptions, the idea of mobility dominated this organization. After Leipzig, due to lack of funds, the coasts were nearly abandoned. The coast guards were abolished in 1815, and the defense of the coast disappeared with the fall of the Empire.

From 1815 to 1870 a series of plans were introduced by several commissions, but most of these accomplished very little. The commissions of 1818, 1823, and 1836 composed of Army officers, established a number of projects for reorganizing the coast defenses, but their work remained a dead letter.

In 1841 a new commission was organized in which the Navy was represented. It formulated a certain number of principles that were just and practical. A continuous line of defense along the coast was not contemplated. Instead, the organization comprised the defense of important points by powerful naval pieces and land troops with advance posts and reserves placed near at hand.

Observation soon disclosed that the defense of the coast could not be divided between two departments, the commission finally deciding that it must fall to the War Department, admitting at the same time that there were reservations to this principle. It proposed that the personnel of the coast batteries be detached from the regiments of other artillery. These plans were approved in 1847. The naval forces were

assigned to a large number of the batteries in the military ports. In 1849 a board of inquiry on the Navy issued the statement that all forts and batteries destined to defend the military ports and their roadsteads should be turned over to the Navy.

In 1859, the commissions of Lebardier, Tinan, and Tourichon studied the means by which the naval personnel could be made to cooperate with that of the Army in the defense of the coast. Finally, the committee on artillery and the Neil commission (1859-1860) made appropriations for twenty batteries for the defense of the coast. This was the only tangible result of all these different commissions.

During this period, from 1870 to 1914, the problem of the defense of the coast continued to be studied from every angle by a multitude of committees and commissions, without ever receiving a clear solution. As a result, the responsibility of the coast defense was still divided in 1914, and the inconvenience of the duality of command was always manifested.

In 1872 a "Committee of Defense" was created, uniting with its other works the defense of the coast. In 1885 this supplanted the commission of 1859. But the "Committee of Defense" was in turn displaced in 1888 by the "Superior Council of War," which alone was charged with questions relating to coast defense. During this time several projects, tending to confide the coast defenses to the Navy entirely, were presented to the Chambers.

In 1881 Minister of Marine Gougeard took the initiative on one of these projects. In 1886 Admiral Aube in turn demanded that the defense of the coast be entrusted to the Navy, but in this he met with opposition from General Boulanger.

The "Superior Council of War" charged its "commission of studies for the defense of the coast" to renew the organization of the coast defenses. This commission proposed to concentrate all means of defense in military ports, the large commercial ports and a certain number of other important points, finally obtaining the disarmament of numerous minor works.

In 1890 a new ruling placed under the control of the naval prefects all the means for the defense of the coast, including the land forces. The general officers, however, remained under the control of the Minister of War. The coast was divided into sectors, and at the head of each was placed a general officer of the Army or the Navy under the immediate command of the naval prefect. This statute still left the responsibility divided between the Army and Navy. In 1892 Lockroy proposed to assign it entirely to the Navy. The rulings of 1894, appearing in the meantime, differed from those of 1890 only in certain details and still left the duality of command in force.

In 1898 the Fashoda incident occurred. A sufficient amount of materiel was available, but the personnel was small and poorly trained. No covering troops were available for the coast frontier. It took from five to ten days to mobilize the coast artillery troops. Only one out of three guns could be manned, and these ineffectively. Algeria, Tunis, and Corsica were in no better position than France. As usual, France knew how to parry the danger by taking rapid initiative. Forty companies and fifteen field batteries were sent by the War Department to the largest ports; volunteers from the army reinforced the naval personnel; the most menaced points were occupied; but mobilization finally had to be resorted to. The crisis over, the question of the defense of the coast was once more taken up. In 1900 the Army took over the naval troops, without, however, gaining complete control of these forces. A decree of 1910 named the naval prefects governors of military ports, and placed them under the orders of Army Corps commanders in so far as the land defense of these ports was concerned.

In the ruling of 1914, the coast sector idea was abandoned and the defense against landing parties was placed under the generals commanding the coastal regions, the defense against the enemy afloat remaining in the hands of the Navy. In 1909 Colonel Rouquerol published a study of the problem which contained many truths: "The coasts are frontiers and the troops that defend them are covering troops. All coast artillery works must be in a high state of preparation, ready to function at any given moment, without being obliged to count on personnel other than that of the permanent garrisons."

During the early part of the World War, the War Department transferred all coast artillery personnel to units of heavy mobile artillery. Naval personnel for the most part replaced the artilleryman, but the War Department remained responsible for the defense of the coast.

The coast being but a secondary theater of operations and with England's assurance of the supremacy of the sea, nothing prevented the concentration of all resources on the west front, whether they were from the Army or the Navy. The Navy cooperated fully with the Army, placing at the disposal of the War Department about 6000 men, creating what was known as the Naval brigade, forming searchlight companies and tractor companies, and manufacturing war munitions. With the development of submarine warfare, the Navy was forced to limit its contribution of personnel to the Army in order to man a large number of submarine chasers.

In 1915 ten posts for the defense of the coast against submarines were organized, and in 1916 eleven more were added. In January, 1917, the coast being in a precarious position due to the limited number of guns and their comparatively short range, preparations were

begun for its reinforcement. Levying guns and ammunition from the coast batteries had left them with a mediocre and incomplete armament.

In February, 1917, an interdepartmental commission for the defense of the coast was created, its mission being the solution of the problem of protection of the coast against submarines. In the spring of 1917, German torpedo boats executed a number of raids on northern ports, and at this time the reporter of the Naval budget demanded that the Navy be charged entirely with the defense of the coast. Two bills were presented to the Chamber with this end in view.

At that time the coast comprised the following—twenty-six forts, of which seven were manned by Naval personnel, under the direction of the War Department, and numerous posts of defense against submarines organized by the War Department on the coast and by the Navy on the islands, which were manned by a mixed personnel from the Army and Navy.

In August, 1917, the Navy prepared a project tending to assume the defense of the coast. The principal arguments in favor of this change were as follows—up to this time, by virtue of the text of 1791, the Minister of War remained charged with the defense of the coast, but, since 1791, war conditions had changed, the struggle against the enemy afloat now demanding a close liaison between the naval and coast forces. This liaison involved unity of command. The Department that assumed the direction of the war on the sea must also be charged with the defense of the coast against the enemy afloat. In addition, the War Department had already transferred a large part of its personnel to other points. Estimating that the Army must concentrate all its resources on land warfare, it could no longer insure the defense of the coast.

After a careful study of the problem had been made by the Ministers of War and of Marine, a decree on September 21, 1917, charged the Navy Department with the defense of the coast against the enemy afloat and gave it the command of all coast artillery units and materiel pertaining thereto. However, this decree did not embrace the zone along the North and Northwest coasts, which remained under military commanders until January 10, 1919. The rulings of the decree of September 21, 1917, were put into effect January 18, 1918.

On May 14, 1919, the Navy Department organized the framework of the offensive and defensive services and charged them with all affairs concerning the defense of the coast. In September, 1919, there was created a "Commission for the study of practical coast artillery firing," which replaced the commission from the Army. Finally, in December, 1921, two decrees, which will be studied in the next chapter, fixed the present statute for the defense of the coast.

## PRESENT ORGANIZATION OF SEACOAST DEFENSES

The present statute for the defense of the coast was fixed by the following acts: Decree of December 27, 1921, for the organization of command of the seacoast defenses; Decree of December 27, 1921, for the organization of the high command of the maritime forces; Inter-ministerial instruction of May 29, 1922, for the application of the decree of December 27, 1921, for the organization of the command of the seacoast defenses; Ministerial settlement of June 2, 1922, for the organization, for military purposes, of such elements as were affected by the Navy Department in the defense of the coast.

This regulation may be summed up as follows: as was stated in the preceding chapter, the decree of September 21, 1917 (complemented by that of January 18, 1918), confided to the Minister of Marine the defense of the coast against the enemy afloat, the Minister of War remaining charged with the defense of the coast against landing forces or those already landed. Unity of command was thus attained in the struggle of the coast against adverse naval forces, but the duality of command reappeared at the most critical moment—when the enemy landed.

Now, the defense against an enemy landing requires an absolute coordination of action of all defensive means, be they naval, terrestrial or aerial, during all phases and all times of the attack. To attain this coordination, the decree of December 27, 1921, proposed that the Minister of Marine must alone be responsible for the defense of the coast against all enemy enterprises.

The Minister organizes and assures this defense by means of those elements pertaining to his department and those of the War Department placed at his disposal.

The coasts of France and North Africa are divided into four large coastal regions, each placed under the command of a Vice Admiral, as follows:

- The North Sea coast and that of La Manche, <sup>the Channel</sup>
- The Atlantic coast,
- The northern coast of Africa,
- The southern coast of France.

Before outlining the rôle of the commanders-in-chief, it is proper that we determine the place they occupy in the naval High Command. In time of war the senior Vice Admiral of the Navy assumes the command of the French naval forces. Under his authority, two Vice Admirals, designated in time of peace, exercise superior command of the two principal theaters of operation, the Atlantic Ocean and the Mediter-

anean Sea. These Vice Admirals, respectively, take the title of commander-in-chief of the naval forces of the North and of the South. Under them are flag officers commanding the high seas and naval patrol forces, and the Vice Admirals, commanders-in-chief of the seacoasts. The latter can, by Government order, take over the command of the theater of operations on land adjacent to the coastal region from the commanding general of the Army.

In peace time the Vice Admirals designated to command the North and South theaters of operations are only general inspectors of the forces that they will command in war.

During activities, the Coast Commander directs the defense of the coastal region by means of all forces—fixed or mobile, terrestrial, aerial or afloat, permanent or temporary—assigned to this defense by the War and Navy Departments. In time of peace it is his duty to prepare these forces for action and inspect them. He exercises permanent authority over the naval forces. The Army may be placed at his disposal for maneuvers to perfect the preparation for the defense of the coast.

From a military standpoint, each coastal region is divided into sectors that are commanded by flag or superior officers of the Navy. These commanders of sectors, who may at the same time be governors of strong points, are directly responsible to the Vice Admirals commanding the coast. For administrative purposes, the division of the coast into districts is maintained. The Naval prefect, placed at the head of a district, is directly responsible in peace time to the Minister of Marine and in war time to the commander-in-chief of the naval theater of operations. He commands the military sector of the chief port and is eventually governor of the strong point. With these two titles he is directly responsible to the Vice Admiral, commander-in-chief of the coast.

In time of peace the Vice Admiral commanding the coast has under his authority as Naval organizations, the Fleet, the Aeronautic forces, the Fixed Defenses, the Coast Artillery, the Antiaircraft, and the Service of Communications.

The Fleet, stationed in one or more ports on the coast, is composed of patrol squadrons, mine sweepers, submarine squadrons, swift scout cruiser squadrons, and mine planters.

The Aviation, concentrated as much as possible in time of peace in the vicinity of naval ports and yards of the coast, consists of squadrons of pursuit planes, bombing planes or hydroplanes and seaplanes, dirigibles (cruising, scouting, and searchlight carriers), and captive balloons for patrolling, regulation of fire, and protection.

The Fixed Defense provides marine obstructions such as mines, nets, torpedos, and torpedo tubes. It polices the waters and roadsteads, organizes a coast detection service including listening outposts, maintains channels of security and searchlight posts not affiliated with the artillery.

The Coast Artillery, the personnel of which is formed in one or more battalions, consists of fixed and mobile batteries; observation posts, command posts, range-finding stations, and plotting rooms; searchlight stations; communications, and artillery observation planes and balloons placed at the disposal of the Artillery by the Aviation.

The Antiaircraft consists principally of batteries of artillery, machine guns, searchlights, barrage balloons, smoke producers, etc.

The Service of Communications assures liaison between the command and the organs of execution; liaison between the various military units with the exception of those which pertain to the artillery alone. It is sub-divided into Radio Service, Service of Observation and Service of Codes.

The Vice Admiral, commander-in-chief of the coast, anticipates its needs and prepares the plan of mobilization and defense of the coast.

For administrative purposes, the rôle of the commander-in-chief is confined to advising the various units under him of their needs in the preparation for war. All these needs, without exception, are furnished by the naval prefects and their services.

The foregoing regarding the functions and means of action of the Vice Admiral commanding a coast permits us to measure the great importance of his rôle. The important task assumed by this general officer requires that he be familiar with administration.

All of this, however, did not come without arousing criticism. In general, all are familiar with the principles of the total assignment of the coast defense to the Navy Department, with the understanding that if, in spite of the efforts of the fleet and the troops, the enemy succeeded in landing sufficient forces to make the invasion menacing, that an army specially constituted of reserves would oppose him and that the commander of this army would exercise direction of all military operations in that particular region. It is also seen that in coast defense the various means of action that are prescribed must all be under a single chief and that this chief must be of the Navy, since the defense of the coast is under the jurisdiction of the Navy Department and that naval forces predominate.

But the following questions arose:

1. Why was the naval prefect, already charged by the decrees of September 21, 1917, and January 18, 1918, with the defense of the coast

against the enemy afloat, not invested with the powers actually attributed to the commandant of the coast?

2. Why were new functions for Vice Admirals created, at the moment when economies and reductions of action were the order of the day?

These questions can best be answered by borrowing from an article by Admiral Ratye the following considerations. It is not a question of creating additional posts for the Vice Admirals of the coast, but of better utilizing those already employed. Prior to 1914, that is, before having had charge of the defense of the coast, the Navy had six Vice Admiral naval prefects and four Vice Admiral commanders-in-chief of the coasts, this being six Vice Admirals for a task on a more extended scale.

"We must neglect the lessons of the last war," writes Admiral Ratye, "to admit that the naval prefects of Toulon and Brest can continue in the future their functions of governor of a maritime station and commander of a large arsenal, with the added obligations of the defense of a coast that enemy aviation can attack at any moment and at any point."

War has changed its form. Too often do we forget it. Today it is necessary that all mobile forces of the coast, aerial, afloat, or on land, be able to concentrate instantly at any point on the coast. And these immediate reactions are possible, with so many various elements, only when there exists a chief who devotes himself entirely to this mission of command and action; at the same time, it is necessary that another chief see that all the principal arsenals produce all that an actual war requires; who directs industrial mobilization, expedites construction, repairs vessels, makes material, and administers the district.

In addition, it must be remembered that the naval prefect, governor of a major port, is confined to the post of commandant of a strong point, while the commander-in-chief of the defense of a coast sector must be at liberty, if necessary, to be present at threatened points on the coast.

#### APPLYING THE MEANS AT OUR DISPOSAL TO THE DEFENSE OF THE COAST

Must we have a coast defense? If yes, then how must it be conceived?

To the first question, Grand Admiral von Tirpitz replies in his memoirs: "In all my career, I have always had to combat two ideas particularly dear to the ignorant—the idea of a coast defense and the idea of a fleet of cruisers destined to sail strange waters. The World War has shown that the best defense for a coast is to possess a combat fleet."

All well and good when we possess a strong combat fleet and are able to use it. In spite of this principle, the Germans were forced to organize a strong defense along the Belgian coast.

"The English," says Captain Avice, "have always considered that their fleet was the most efficient factor in the protection of their coast. Their theory of defense and offense is summed up in the formula, 'the first line of defense is the enemy's own coast.' " Nevertheless, beginning with 1859, England occupied herself with putting her armaments and naval bases in a state of defense; and in 1889 she undertook the organization of points of support, or naval bases, for the fleet, on the hypothesis that she was no longer mistress of the sea and that should her fleet be dispersed or suffer defeat, the ports and arsenals could count only on their own resources to repulse an enemy attack.

While realizing that the best coast defense is mobile and that the high seas forces are most efficacious, we must not neglect other means of defense.

If the English, in spite of their naval supremacy, understood that a strong coast defense organization was necessary, we can firmly say with Mr. de Chappedelaine, reporter of the budget of the Marine at the Chamber of Deputies, "that France, equipped as it is with a reduced naval forces, financially incapable of building capital ships, is obliged, by this very fact, to superintend attentively the defense of its coast, more than any other nation."

To answer the second question, we must see how a formidable attack from a fleet would take place. Powerful squadrons composed of heavy armored dreadnoughts, nearly invulnerable to a torpedo, carrying guns with a range of over 40 kilometers, well concealed from the coast by thick smoke screens, assisted and covered by squadrons of submarines and airplane squadrons, would be used by the enemy.

Such a force is able to attack and destroy a commercial port, annihilate a naval base, or to capture a roadstead preliminary to landing operations. It has only to choose a means of attack—aerial bombardments, artillery bombardments, mine planting, blockading, submarine attacks, bottling the ports, attacking the ports and sending torpedoes, gas warfare, harassing parties along the coast, massive landings, etc.

To repulse the enemy attack, the defense disposes all its naval, land, and aerial elements. These elements are classed in two large categories:

1. *Passive means*—obstructions such as mine nets and submarine nets, barrages, captive balloons, etc.

2. *Active means*—reconnaissance units, submarines, patrol boats, hydroplanes, coast airplanes, and aerial cruisers; combat units, mine

fields planted at large in the enemy's path, torpedoes launched by hydroplanes and planes, by submarines and batteries of torpedo tubes by the sea, bombing planes and hydroplanes, pursuit planes, coast artillery, antiaircraft artillery, and, finally, Army troops ready to repulse any move towards disembarking.

Certain critics ask why all efforts towards coast defense are not directed to aircraft and submarines, which are more modern means of defense. They point out that the present artillery installations are too costly and that funds for the defense could be used more judiciously by increasing aerial and submarine forces.

Doubtless aircraft has an immense future. Much has been said of bomb dropping on old battleships, recently executed in the United States, one squadron dropping bombs from an altitude of 2000 meters and obtaining six direct hits out of twelve bombs dropped. Experience has also shown in the United States that it was possible to direct airplanes by radio for a distance of over ninety miles and to load them with explosives. The same holds true for submarines which are constantly being perfected.

But the old coast artillery arm—the gun—will still have an important rôle. "It takes time for planes to take to the air. It takes time for submarines to overtake an enemy that appears at large. *Only artillery can enter into action immediately.* And so we ask that a certain force of artillery be provided to defend all channels and passes of our large ports." \*

The defense cannot expect to stop entirely an assailing force by means only of aerial bombardments, torpedoes, and mine explosions, the functioning of which may be paralyzed by aviation, submarines, and mine sweepers. But if the attackers succeed in penetrating the barrages formed by the aerial and naval forces, victory will not be decided in their favor yet, for they will have to encounter another powerful obstacle—the artillery. Let this obstacle be rationally organized with powerful rapid-fire guns, plentifully provisioned and munitioned, concealed from view from the sea or at least observed with difficulty from enemy vessels, provided with a judiciously installed system of observation and range finding, and the assailant will be unable to silence them unless possessed of a crushing superiority.

This necessary artillery cannot be distributed along the whole coast. Therefore a good proportion of it should be mobile and capable of concentrating rapidly at points of attack; it will be also necessary that a certain number of fixed batteries, capable of immediate action, be installed; if these latter should be especially for the protection of naval

\* *Journal Officiel* of December 19, 1922. Discussion in the Chamber of the Marine Budget, Minister of Marine.

bases and large ports of commerce. Powerful batteries with a range of 40 kilometers or more must be provided for the defense of vital points that would be subject to bombardment by the enemy from long distances. These battery emplacements should be chosen in such a way as to be capable of mutual support. Their action would be supported by minor artillery batteries and secondary batteries, and batteries of light artillery designed to protect passes and entries into ports and roadsteads. Finally, artillery for defense against aircraft, in sufficient numbers and well equipped, would be charged with the protection of ports against aerial bombardments.

There results from the preceding sketch the fact that the defense of the coast implies the putting in action of all means of modern war. The task will be a severe one and will imply heavy responsibilities, but France knows how to make the necessary sacrifice, for if she cannot admit that her borders remain open, "she can no more admit that her coasts remain defenseless."

We are as brave a people as live, but bravery unarmed means useless sacrifice of the best men. We are ready to fight, but an unarmed people cannot fight a fully armed and equipped body of men. How are the bravest people in the world to spring to arms when they have no arms to spring to?—*Senator Henry Cabot Lodge.*

# Railway Communications and Fire Control

CAPTAIN GEORGE W. RICKER  
*Coast Artillery Corps*

---

## COMMUNICATIONS

*a. General.* The telephone is by far the most important agency of signal communication. Since the war many experiments have been conducted with a view to learning the best methods and systems for using this instrument. It has been found that, in general, the common battery telephone system is unsatisfactory for mobile artillery. Many of the lines employed by mobile artillery are too long to operate efficiently on common battery. In one battery position that I occupied the secondary station was ten miles distant from the firing position; the battery personnel strung more than twenty-six miles of twisted pair. Some commercial companies have adopted a distance of five miles from the central storage battery as the distance not to be exceeded for common battery operations. Such commercial operation is usually under the most favorable conditions, whereas artillery fire-control phones receive much harder usage than commercial telephones. They are frequently used continuously for several hours and are often operated over lines which have been laid under conditions anything but favorable for common battery operations. Common battery systems require more equipment, especially for power, than do local battery systems. The most serious objection to the local battery system is the necessity for having batteries at each telephone, but this difficulty is not insurmountable, and, all things considered (especially the recent advancements made in dry-cell battery design), the advantages of the local battery system far outweigh this one objection.

In addition to the telephone system the other means of signal communication are the message center, the messenger system, the radio system, and the visual signalling system.

*b. Regimental.* It is not contemplated that regiments of railway artillery will, as a general thing, take the field, either in seacoast operations or in land warfare, as tactical units. The basic tactical unit is the battalion. Nevertheless, the system of communications described below treats of the regiment as a tactical unit, with the idea that this system, with a few modifications, will apply to a groupment of railway artil-

---

\* Lecture delivered at Unit Camp, 601st C. A. (Ry.), Fort Andrews, Mass.

lery. The command, administration, and tactical control of a railway artillery groupment is the normal assignment of a regimental commander and his staff.

(1) When the regiment is stationed in a harbor defense, use is made of such of the standard harbor defense telephone installation as may be available and of other existing means of communication.

(2) When the regiment is stationed near a harbor defense command as much use as possible will be made of the fixed installations; otherwise, and in land warfare, the *general system communications* will be as prescribed in T. R. 160-5, *Signal Communications for all Arms*. The regimental communications detail must also be prepared to establish communication with outside agencies such as lighthouses, coast guard stations, beach patrols of the mobile forces, and patrol vessels and other agencies of the naval coast defense forces. The possible necessity of locating observing stations beyond water areas may make it impossible to establish wire communication and necessitate the use of radio or visual signalling.

The message center is established near the regimental command post by the message center detail of the headquarters battery.

When necessary a messenger system of motorcyclists is established by the message center detail and maintain service from the regimental command post to the battalions; auxiliary services and units, naval forces, coast guard, etc.; supported units; neighboring harbor defense commands; or other artillery units.

The wire system is installed and maintained by the telephone detail of the headquarters battery. Lines are run from the regimental command post to—

Battalions,  
Regimental observation posts,  
Supported units,  
Auxiliary units and services,  
Neighboring harbor defense commands or other artillery units.

When conditions are favorable, the radio telephone may be used for communication with distant observation posts. When these are located beyond water areas, radio may be the only means of communication which can be installed in time to be of use.

Visual signalling will be under the control of the radio detail of the headquarters battery. Flags and projectors may be used to communicate with patrol boats; rockets will be used by beach patrols and by patrol boats; radio will seldom be used by regimental headquarters, as radio communication with planes will normally be maintained by

batteries, and no provision is made for the regiment in the railway artillery net.

*c. Battalion.* The signal agencies of the battalion are the same as for the regiment except that the installation is rather more complicated. The wire system includes both a telephone system and, in seacoast operations, a time interval system.

(1) For seacoast operations the following lines are run from the battalion switchboard (12-drop board) :

- To the battalion command post,
- To the armsetters in fire control car or plotting room (2 lines),
- Two sets of two lines in parallel, one branch of each running to the switchboard of each battery, where it can be connected to the lines to the batteries' armsetters,
- Two lines, one to each battery C. P., through the respective battery switchboards.

From the 4-drop board in the battalion C. P. there are lines to each base-end station and to each armsetter. In addition to these there are the two spotters' lines which run direct from spotting stations to plotting room without going through a switchboard.

In land warfare there is no need for a time interval installation, and the lines from the battalion switchboard may be reduced to a line to each battery, and a line to each battalion observation post. The battalion will also run a line to the battalion on its left and, if the situation requires, to the unit which it is supporting.

Except for ground to ground communication where no other means is available, radio will not be used by the battalion. The battalion is not included in the army railway artillery net. As in the case of the regiment the use of radio in seacoast operations will depend entirely on the situation.

In seacoast operations the battalion functions like the group in the fixed defenses. It therefore establishes and operates a base line and a plotting room. In connection with this it needs a time-interval installation. The installation consists of a motor driven T. I. mechanism. It takes about one ampere at six volts and operates about 100 hours on a single charge of the storage battery. For railway artillery the T. I. bell system, used on the comparatively short lines of the fixed defenses, is not satisfactory. Five miles seems to be about the limit for installations of this type. On account of the longer lines usually employed by the railway artillery, it has been necessary to devise some other means of getting the T. I. signal to the distant stations. After many experiments this has been most satisfactorily accomplished by having the T. I. circuit inductively coupled to the observers' lines, so

that each time the apparatus makes and breaks contact a click is heard in the telephone receivers. In the system for the firing batteries it is necessary to make provision for a T. I. signal at the guns. This is done by the use of relays, which make it possible to ring a T. I. bell of standard type at each gun.

*d. Battery.* The signal agencies used in the battery are the same as those employed by higher units. In addition the battery always operates a radio set, both as a part of the railway artillery net and for communication with observing planes.

(1) *Telephone system.* Like the battalion, the battery in seacoast defense installs two switchboards; a 4-drop board in the battery C. P. and a 12-drop board in some convenient and well protected locality. The battery command will require the following lines:

- From B' to plotting station.
- From S' (spotter at B') to plotting station.
- From B'' to plotting station.
- From S'' (spotter at B'') to plotting station.
- From range or elevation board in plotting station (No. 1 data phone) to guns. (Phones at guns to be in parallel.) Maximum of two lines, depending on locations of guns.
- From azimuth or deflection board in plotting station (No. 2 data phone) to guns. (Phones at guns to be in parallel.) Maximum of two lines, depending on locations of guns.
- From the C. P. to switchboard.
- From Battery Executive to switchboard.
- From plotting station to switchboard.
- From B' armsetter to switchboard.
- From B'' armsetter to switchboard.
- From switchboard to battalion switchboard, 3 lines (installed and maintained by battalion).

In every seacoast fire-control installation it is necessary that the battery commander be able to communicate with the B' and B'' observers, primarily for the purpose of placing them both on the same target. In the fixed defenses a separate line to both stations, known as the Intelligence line, is usually provided for this purpose. To obviate the necessity for such a line in railway artillery installations, the B' reader's phone and the B' armsetter's phone are connected through a type BD-9 switchboard (4-line) in the battery C. P. The secondary reader and armsetter are connected in like manner through the same board, and each observer has a headset in parallel with his reader's headset. By means of the monocord operator's set of the 4-line switchboard the B. C. can plug in to either or both of the O. P.-plotting room lines and talk to his observers. The spotter's lines are directly connected without going through a switchboard.

(2) *Radio system.* The Army Railway Artillery Net consists of one radio station at Army Artillery Headquarters, and probably a maximum of about three battery stations. Such battery stations will be specified in field orders at the time the batteries move into position. Where railway batteries are located near the main wire axis of the Army or of a Corps, wire communications only will be used for ground to ground messages, and radio stations will not be put in commission except when needed for communication with observing airplanes. One wave length per army will be allotted for this net.

For the airplane observation service the radio stations of batteries not assigned to the army artillery railway net will be used in so far as practicable. When this is not possible the net stations will be relieved from the net for airplane observation service. Five wave lengths per Army will be allotted for airplane observation for both tractor and railway artillery. Arrangements similar to those set forth above will obtain in seacoast operations. The net will probably be a sector net, and instructions will be issued by the sector commander.

#### FIRE CONTROL

*a.* For seacoast operations the fire-control system for railway batteries is similar to that employed in the fixed defenses. The most important differences are that the system and equipment must be sufficiently flexible to meet the needs of all possible situations. Other controlling factors that have necessitated some departure from the standard system are: the use of the panoramic sight, the 4-gun battery, the comparatively large area over which a battery may extend, and the fact that Case III is the normal method of aiming and laying. These points are all covered in an article in the COAST ARTILLERY JOURNAL, "Railway Artillery Developments Since 1918," October, 1924. The required degree of flexibility or adaptability is obtained largely by the use of the Cloke plotting board which can be oriented to conform to any situation in a very few minutes.

In land warfare much simpler methods are possible. About the only equipment necessary are a firing map, firing board or impact chart, firing tables, and communication with each observation post. The Cloke board may be used, but the use of an impact chart or improvised firing board will be found to be simpler.

*b. Emergency Methods.* Each battalion will establish not less than three base lines; *i. e.*, one by the battalion and one by each of its batteries. The wire communication installations are so arranged that either battery can, at a moment's notice, get data from any one of these base lines. Thus, if a battery has a station out of action or loses communication with one of its stations, all that is necessary is to plug in

to the base line of the battalion or of the other battery, re-orient the plotting board, and go ahead with the action. It does not seem probable that all three base lines would be out of action at the same time. Other methods that have received consideration are the use of depression position finders, self-contained range finders, and position finding by airplane. The use of depression position finders is feasible only when stations of adequate height of site are available. No coincidence range finder has yet been adopted as standard for the railway artillery, but it is believed that one of about 20-foot length will be found that will come somewhere near to meeting the requirements of accuracy, medium size, and portability. Position-finding by airplane will be discussed under the next heading.

c. *Fire Control Beyond the Range of Vision from Shore.* At present the only means of accomplishing this is by the use of airplanes. The airplane observer reports the initial location of the target, the direction in which it is going, and its speed, in code, by radio telegraph. There are different methods of determining the initial location of the target. The simplest and most satisfactory is the map method. The observer estimates as closely as possible the location of the target on a 1/80000 map bearing a magnetic grid, its speed in knots, and the magnetic bearing of its course. He reports these data in code to the battery plotting room where the target is located on a magnetic grid on the plotting board. By means of the direction and speed the course is plotted and a setforward point is located. Firing data are computed as usual. The observer reports the fall of shots and any changes in speed or direction of the target. If maps are not available the initial location of the target may be determined by tracking the airplane with an oriented observing instrument. When the plane is directly over the target the observer gives a prearranged signal and reports his altitude. The azimuth reading of the instrument will be the azimuth of the target and solution of the right triangle (of which altitude and angular height of the plane are known) target-plane-O. P. will give the range. Objections to this method are that it requires more equipment, is much slower, and that it is very difficult to track and identify the right plane at long ranges. A variation of this method is the mid-point method, in which the observer reports his altitude and gives his signal when he has reached a point which he estimates is half-way to the target. The same objections apply. Also, the results depend entirely upon the correctness of the observer's estimate of the location of the mid-point. Obviously the solution of the right triangle will give one half the range. Another method is by radio intersection. For the use of this method, two or more goniometric radio receiving stations must be available. The observer signals when he is directly over the target. By the use of highly

directional coils the angles from the radio stations are determined and plotted and the target is thus located. These methods were all tried during the joint maneuvers of the Coast Artillery and Air Service in 1922. The map method gave by far the best results and was the one chosen for use in actual firing problems. In all methods the observer estimates and reports speed and direction of the target as explained in the map method.

*d. Map Firing.* This method is used only in land warfare, and then only when more accurate means of locating the target are not practicable. Range, azimuth, and difference in height of site of gun and target are taken directly from the map and firing data are computed thereon. When observation is available the fall of shots are plotted on an impact chart or firing board.

*e. Spotting.* Both in land warfare and in fire at naval targets there will undoubtedly be much firing done under conditions which will make spotting impossible. Nevertheless, observed fire is of such unquestioned value that means must be at hand for carrying on satisfactory spotting whenever there is any opportunity to do so. Spotting may be done from balloons, airplanes, or terrestrial stations. Bilateral spotting from terrestrial stations is the most accurate method but it is also the slowest, most cumbersome, and requires the most personnel and most equipment, including long lines of communication. Balloon spotting is rapid and simple but the results for range are usually far from accurate. About all that can be expected from balloons are fairly good deflection readings and some sensings in range. Spotting by airplane observers is, all things considered, the most satisfactory. It is by far the quickest; the report is received almost before the splash has died away; with a trained observer the results are quite accurate enough for all practical purposes; it requires little or no equipment. If the observer is reporting splashes with respect to the battery-target line no apparatus is required aside from a radio set; if the "clock code" is being used the only additional equipment necessary is a simple clock spotter.



COLONEL JOHN DE BARTH WALBACH

*Commandant, Artillery School, October 13, 1829, to December 12, 1830*

# EDITORIALS

---

## *Specialization*

THE name of an officer, introduced in a recent conversation, brought forth the remark that this officer felt he had injured his professional standing by too high a degree of specialization. The talk then turned to the value of specialization to an officer, and the arguments, both pro and con, waxed hot and heavy. It can scarcely be said that there was a consensus of opinion beyond the admission that the Army itself profited by specialization on the part of its personnel. The discussion centered about the advantage to an officer himself of becoming recognized as an expert in some one particular line.

The officer whose name brought about the discussion was, a few years ago, an outstanding authority on a subject in which the Coast Artillery was, at that time, much interested. The war came along and brought with it many new problems and new interests. Our attitude towards many things underwent material modification. Our viewpoints altered. We are not now, to any great extent, directly interested in that particular subject. What good, then, did it do that officer to become a specialist? It is true that the service profited from his researches, that much of our advance was due to his efforts; but is he now any better off for the many long hours he spent in study, investigation, and experiment? Does any officer improve his ultimate standing by specialization?

It seems to us that the answer is found in the old, familiar "That depends." It depends upon the character of the chosen field; it depends upon the rank and experience of the officer; it depends upon the effect that study towards specialization has upon the performance of present duties; and, above all, it depends upon the extent to which preparation for future duties is affected.

Back beyond the memory of the present active list, the Army produced many recognized authorities in botany, zoology, geology, and kindred subjects. These were taken up as hobbies in the days when the Army was scattered in small detachments all over the country, with little to fill the time other than an occasional Indian raid. The introduction of rifled cannon, armored ships, capped projectiles, and smokeless powders brought new interests, and the last two decades of the Nineteenth Century gave us, in the Artillery, a number of outstanding

specialists in ballistics, explosives, chemistry, and similar subjects, and initiated research in the fields of gunnery, position finding, submarine mining, and so on.

Since the opening of the present century, and particularly since the recent war, the life of a Coast Artilleryman has become complex. He serves with antiaircraft troops today and with a railway battery tomorrow; next week he goes on detached service—perhaps to teach school, perhaps to run a mine planter. It is difficult to see how, in the ordinary course of events, an officer can afford to take the time to specialize in any subject except it be strictly in line with his current duties.

The first and foremost duty of any officer is to prepare himself to perform with the maximum efficiency permitted by his capabilities the administrative and technical duties for which his current assignment calls. He must then prepare to take upon himself any assignment to which his rank and age may make him subject. His third care must be to see that he is ready to take the field in active service in at least one grade higher than his present rank. And fourth, he must look to the future so that increased rank and increased responsibility may not find him unprepared. Then and then only, can he specialize.

When he comes to the point of specialization, the subject itself becomes of importance and must be chosen judiciously. For example, a young officer, assigned to an antiaircraft gun battery, becomes interested in antiaircraft gunnery—a subject of importance and one in which much progress remains to be made. His routine duties have already caused him to devote considerable study to the subject. Shall he take up research with a view to establishing himself as an authority in antiaircraft gunnery? Even if he has reached the stage where he can contemplate specialization, would it not be well to consider the probable future of the antiaircraft service? Is the subject going to continue to be of major importance to the Coast Artillery? Is it capable of development? Is development necessary, or even important? Will the officer be any the more valuable for knowing all that is to be known on the subject? How long will the officer be in a position to conduct his researches? The answers being favorable, specialization is indicated.

The whole matter seems to come to this: Specialization is a fine thing for the individual, *provided* (1) that it does not lead him to neglect preparation for his broader and more general duties as an officer; (2) that the chosen subject is not so narrow or of so temporary a value as ultimately to leave him stranded with a fund of detailed knowledge of no value to himself or to the service; (3) that the results of his researches are made available to the service at large; and (4) that he retains his sense of values, for there is such a thing as being unable to see the forest because of the trees.

## *Writing an Editorial*

JOURNALL OF YE EDITOR

*Extract*

25th (Lord's Day). Forbore going to church this morning that while my wife was abroad might write an editorial as I must do. Read the paper and then stept to my office for the mail and so home and to dinner with my wife of roast fowle of which I did make a very great meal. After noone came to see me and sat with me Ruhlen, who tells me the newes. Anon he up and departed and I read somewhat of Ward's *Animadversions of Warre* which is most interesting. And so to supper which our onlie mayde being out was scant for which I forbore to upbraid my wife. Towards the evening, as I have been wont to do, made John shew me his lesson in arithmetique in which he does scarce passing well which not being done I was fain to beate him, but desisted. And so to prayers and to bed, editorial being not writ.

26th. Up betimes, and while breakfast was providing, to my study to plan an editorial, and so to breakfast and to my office where first I read the newes. Thither by and by came Eddie Cullen, and we sat a pretty while talking of many matters of state till noone. I was not unwilling to heare him, for he is full of words. Then home to dinner where I heare of the deficiencies of our mayde and so back to the office to write the editorial where Gardner calls up and proposes a game of golfe, I being the onlie man he can nearlie beate, but he improveth and shortly I can but nearlie beate him for to me the game is trulie one of hooks and slices. I yield to temptation and anon in comes he, and I lose but foure balles and my temper, and so content to home againe and to supper and, editorial not writ, to bed.

27th. Up pretty betimes and drank my morning draft of Java so to the office to write that editorial where I sat with pencil in hand and nothing in head, and so read I Verstegan's *Restitution of Decayed Intelligence in Antiquities*, which is a pretty book but do make us out all Germans, and so home to dinner. Abroad in the afternoon where I stept over to the School to seek an idea but none was to be found and so home and to supper. Thence with my wife to the Liberty Theatre which is like unto a barne and did meet with Dr. Dovell who sat with us to see "Behind the Front" which is an amusing play but which he did not approve of, and so to his lodgings and did play a little at cards with him and his good lady and she did bring out a collacon of cheese cakes and tarts and beer (neare), and so up and away home and to bed, no editorial yet writ.

28th. Up at 6 o'clock, which is the houre I now intend to rise at, and to my office a while where I start an editorial, but getting nowhere fast, to home and to dinner. In the afternoon golfe again but with Dutton who I verilie believe do prefer golfe to labour but who do play a sad game, and so having trimmed me soundly home again. After supper half an houre at my piano. Then to Putney's. There saw his radio which he shewed me and indeed is a pretty toy and home-made but do play foule musique this time of the yeare. Anon took my leave and so home. No editorial writ, but to bed.

29th. At 8 o'clock I up and find myself and family well, onlie my wife and the children sicke with the gripepe. Sat till noone to write the editorial, having no thoughts, and thence to dinner. A foule day and it rayned, and so abroad and to the barber's and there was trimmed. Thence to my office where late and so to supper. At night to my office and did business but no editorial writ and so home and to bed.

30th. Up early to my accounts and I find myself, when my bills do be paid, worth clear \$2.00 which is the most I ever had yet, and so thanks be. Thence to my office, resolved to fall to work again as I used to do, but no ideas and so I up and abroad to buy a dish of cold creame and other things. All the afternoon sitting at the office till late. Then to the Club where (being invited), with my wife, Tubby Meyer did give us a very pretty dinner and we were very pleasant. Then to the dance where I did dance with our hostesse, who danceth in such good fashion that maketh me to think I might myself do right well did I but practice somewhat. And so weary home and with pleasure to bed, no editorial writ.

1st. Lay pretty long in bed thinking an editorial and then I up and to the office a while where all the morning and so to dinner. In the afternoon by auto with my wife to Hampton who I dropt at the Five-and-Ten while I long waited. Thence home and to supper. Thence to the living room whither comes by and by the Achesons and sat playing at cards till it was late, and so good night. Thus endeth the week with but little done but I shall I hope come soon to business again and so, no editorial being writ, to bed.

2d. (Lord's Day). I rose in good temper and to church where I slept most of the sermon and so home and to dinner. Thence to the office to get the mail and there did find a letter from S— who hath many ideas and tells me many things. He did say for me what I fain would say and so I strike salutation out and mark the whole "Editorial," and so home and to supper and, editorial being writ, quiett in mind to bed.

### *Not Again, Thanks!*

Great industrialists, gathered in the American fashion at a banquet, ask the public to rely on the great industrialists "nobly and unselfishly mobilized" to take care of the country in war.

The public will say, "No, thank you, we tried that last time. What happened? The mobilized industries squandered a billion or so on airships that never flew and another billion or so on wooden ships that never left their docks. Our industrial kings proved to be excellent spenders of public money, but poor performers."—*San Antonio Light*.

### *Legislative Preparedness*

The Secretary of War is not in sympathy with those who believe in the efficacy of laws designed and enacted for the purpose of outlawing human conflict. He proposes a new preparedness program for this country, intended to be automatically operative in time of war. This program has been outlined by the Secretary to the House Military Committee. The plan is described by him as "legislative preparedness," and contemplates enactment in peace time of war measures, with the duty of putting them into effect in a national emergency entrusted to the President.

Secretary Davis urges the creation of a Council of National Defense. This council would formulate preparedness plans which would be

passed by Congress. The enactment of such measures as the selective draft, plans for the financing and mobilization of industries, would enable the Defense Council and the President to act promptly in the event of war.

Under such a procedure there would result no such sad delay as happened in 1917, when forty-five days—a long enough time in which world empire might be lost, or won—elapsed before the draft law went into effect. It was a time when every minute was fraught with mighty potentialities for good or evil. Under the Secretary's proposed plan such a delay would be impossible and the President would go ahead with war preparations as soon as emergency appeared.

The proposed Council for National Defense—and it may be expected that it will be sneered at, decried, hooted at, vilified and antagonized by every yellow, pink and red internationalist in the land—would be composed of the Secretaries of War and the Navy, Assistant Secretary of Commerce, the Chief of Staff of the Army and the Chief of Naval Operations. This board would study all situations and problems relating to preparedness and to the coordination of department efforts and make recommendations to the council.

The bill would give to the President adequate war powers; power and authority to create and establish such Federal agencies as he may deem to be necessary and desirable to make effective approved plans for the development and efficient utilization of the man-power and industries, finances, transportation and other national resources essential to the national defense.

The Secretary of War pointed out to the committee that modern warfare no longer is a matter for the Army and Navy. It is a matter for all the resources and activities of the country, particularly industrial, as well as strictly military efforts.

Here is constructive reasoning. War has not been abolished from human experience, nor will it be for generations to come. The United States is a peaceful nation, but it also is the richest nation on the face of the globe. There still are many nations not particularly impressed by altruistic argument.—*Cincinnati Enquirer*.

### *The Army Housing Bill*

The House of Representatives took a step toward remedying a disgraceful and pitiable condition when it passed the war department housing bill. The report on the condition of American army barracks which the Secretary of War made in his last annual statement would have been incredible if it had been tendered by anybody except a responsible officer of the government. A considerable part of the hous-

ing facilities for enlisted men and officers alike were worn out, tumble-down buildings which are dangerous both to health and to life; and many of the barracks are fire traps which may easily become scenes of fearful tragedies if anything goes wrong. Altogether the places in which the personnel of our regular army is obliged to live would be discreditable to a third class power. And the war department chief says plainly that they are responsible for many desertions and produce bad morale. Incidentally few if any posts are more in need of rehabilitation than is Selfridge field, which at last seems to be in line for some real attention.—*Detroit Free Press*.

### *Attention, Young Americans!*

The meddling, and maudlin, opponents of military training continue their efforts to accomplish the abolishment of this practice throughout America. They assail the colleges which require, or permit, military instruction and training. They are loud in their vociferations against militarism, declaiming, often, that this nation is trending toward that status. They are loud in their decrying of appropriations for the national defense. In hysterical assemblies, over tea and pastry puffs, they resolute with a fine emotionalism against guns and warships and battle flags, emphasizing by such lachrymal evidence their sympathy with the fathers and mothers of boys who may be called upon to risk their lives in the service of the republic. They go about preaching a piffing pacifism that, if encouraged and adopted by the United States, would place this Government and its people at the mercy of the still normally human world—a world of men who still are ready and willing to fight for national aggrandisement, for revenge, for extensions of warring creeds, pagan faiths, racial hatreds.

What the average half-baked pacifist needs is a poke in the intellectual solar plexus. He justly may be accounted among the republic's sinister and insidious enemies. He may be well intentioned. But who can work greater havoc than a fool, unrestrained in his folly—*Cincinnati Enquirer*.

# PROFESSIONAL NOTES

---

## A Proposed Method of Tracking Moving Targets Using Aerial Observation

By LIEUTENANT GEORGE A. PATRICK  
*Coast Artillery Corps*

Due to the ever-increasing range of modern cannon and the consequent increasing difficulty of accurate plotting and spotting at long ranges using terrestrial observation, the necessity for a satisfactory method of plotting and spotting through the use of aerial observation is becoming more apparent daily. Even at medium ranges difficulty is experienced in satisfactorily plotting the course of a target and of spotting when visibility is poor, and we may expect visibility to be poor on account of the ability of an enemy fleet to lay smoke screens to hide its movements.

No great difficulty has been experienced with aerial spotting and, as this paper deals with a method of plotting, the subject of spotting will only be mentioned in so far as it affects the proposed method of plotting. The method described below is believed to be extremely flexible in that each battery may compute its own firing data from the data furnished by the plane, or any battery may furnish data from which any number of batteries may compute their individual firing data.

Use is made of existing fire-control apparatus with slight modification. Three simple mechanical devices are used to facilitate plotting, to shorten the predicting interval, and to obviate the necessity of having to convert data from one unit of measure to another.

A prerequisite of the system is that all batteries must keep a system of time that is exactly synchronized with that kept by the aerial observer. A suggested modification of the present T. I. bell system is to have in each plotting room and at each gun emplacement an electro-mechanical device which will accurately indicate the time in hours, minutes, and seconds. These indicators should be of construction similar to an automobile mileage indicator and operated by the present time-interval apparatus modified to send out impulses every second. Adjustment knobs should be provided to allow all batteries to set their indicators at an announced time before the power is turned on at the fire-control switchboard. The switchboard, coordinating its time with the plane, will turn on the power so that the indicators will be in step with the plane.

Another requirement is that the plotting boards of all batteries, as well as the maps used by the aerial observer, be marked off into squares corresponding to the approved U. S. grid system and that they be numbered according to the grid coordinates pertaining to the particular locality.

The mechanical devices mentioned above will be described here as an understanding of their construction is necessary to understand their proper use.

The first is a circular plotting protractor of transparent material and of suitable size. The circumference of this protractor is graduated in degrees and a pointer is inscribed so that it is away from the zero graduation in the proper direction by an angle equal to the algebraic sum of the magnetic declination and convergence at the place. Thus when the pointer is made parallel to the north-

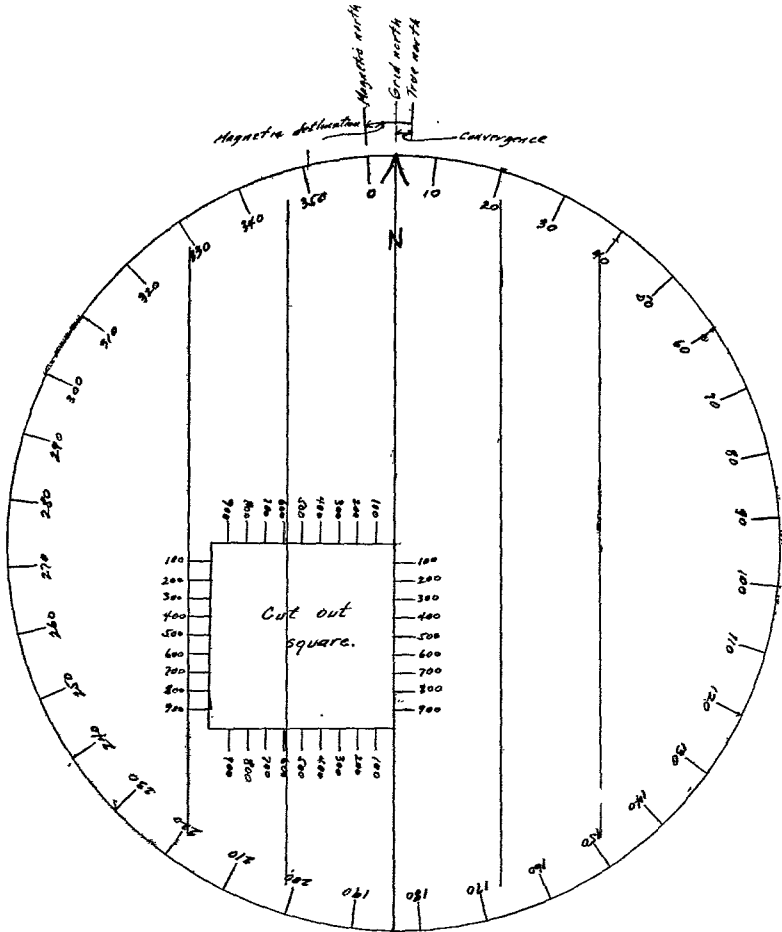

FIG 1. PLOTTING PROTRACTOR

south grid lines on the plotting board the zero of the protractor will be pointing to magnetic north. When the observer reports the bearing of the course of a target (measured clockwise from magnetic north) it may be marked off directly on the protractor and it will be corrected for declination and convergence. A square is cut out in the southwest quadrant and the edges are graduated in divisions equal to 10 or 20 yards each (to the scale of the board). This is used to plot accurately the positions of a point between the 1000-yard grid lines on the board and also to determine the coordinates of a located point. Parallel north

and south lines are inscribed on the protractor to facilitate its orientation. To plot a point of given coordinates the pointer must be pointing north, the hundreds of yards are set off on the edges of the square, and the desired point will be at the center of the protractor and the protractor will be correctly oriented.

The second device is a circular spotting protractor of transparent material and of suitable size. Twelve radial lines extend from the center to the edge and are spaced to correspond to the hours on the face of a clock. Concentric circles

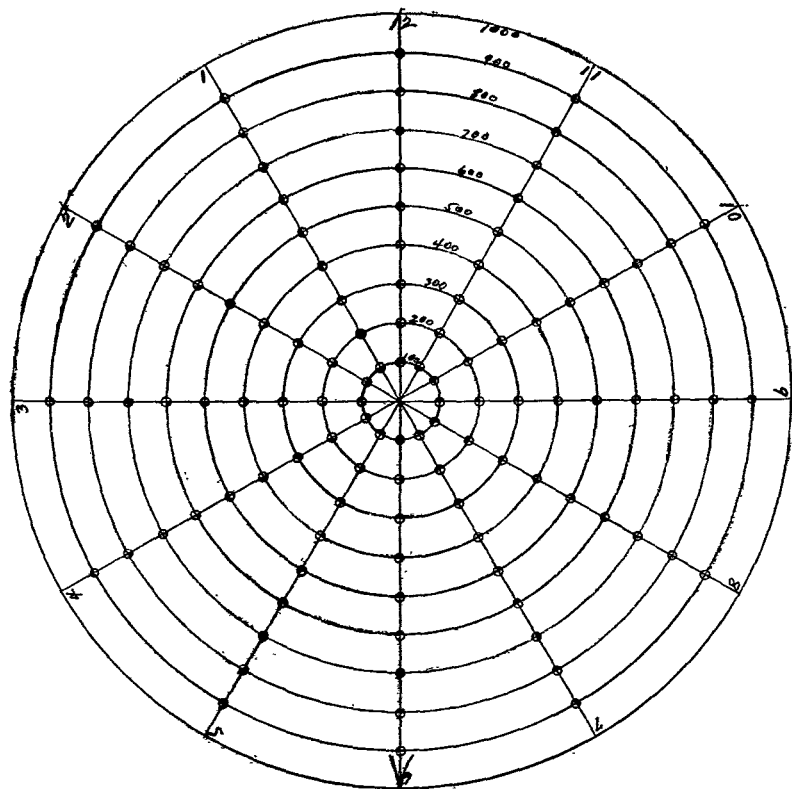

FIG. 2. SPOTTING PROTRACTOR

are inscribed 100 yards apart and small holes are punched at the intersections of the radial lines with the circles. This will permit the insertion of the point of a pencil to lay off a reported deviation. A pointer is inscribed at six o'clock and the hours are numbered *counterclockwise*.

The third device is a predicting-interval slide rule similar in construction to the ordinary setforward ruler. One side is numbered in speed in M. P. H. and the opposite side in travel in yards during two minutes (taken as the minimum predicting interval). The slide is graduated in seconds with an index so that travel during more than two minutes may be determined. This will permit predicting at times other than a fixed number of minutes after the time of observation or will permit predicting on an even minute although the observation is made between even minutes. The assistant plotter keeping the index set at the re-

ported speed, in M. P. H., reads the travel to the setforward point in yards to the plotter who marks it off with an ordinary prediction scale.

The aerial observer locates the position of the target on his map by visual resection using known reference points on the land or water, if possible, otherwise he uses another method. He then determines its course, degrees from magnetic north, using his compass; he estimates its speed and notes the exact time the observation was made. Reading the X and Y coordinates from his map, or giving the estimated range and azimuth, he radio telephones or telegraphs the data to the radio station in some form such as: LOCATION X 1890—Y 2360, BEARING 170, SPEED 15, TIME 9:00. The plotter takes his plotting protractor and using the coordinates received plots the position of the target on the board. As his protractor has been oriented during the plotting he can mark a point at the bearing. Joining the two points will give him the course of the target. He then locates the setforward point, using the travel furnished by the assistant plotter. If the data are being computed for his battery alone he can place his targ on the setforward point and read the range and azimuth to it, using the gun arm. However, if the data are to be used by several batteries he determines the

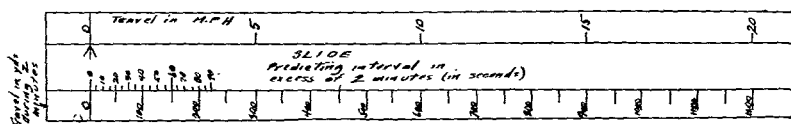

FIG. 3. PREDICTING SLIDE RULE

coordinates of the setforward point and transmits them to the batteries where the point is replotted and firing data computed. The assistant plotter announces the time at which the target is predicted to reach the setforward point. The time of flight is determined and is subtracted from the predicted time and the time at which the gun must be fired is sent out to the guns.

Let us assume that a minimum predicting interval of two minutes is necessary. This interval includes the dead time of receiving, plotting, computing, transmitting, and setting the data. Time of flight is also included as noted above.

Since the position of the target was observed, say, at 9:00, the setforward point, using a predicting interval of two minutes, represents the position at which the target should arrive at 9:02, provided everything has been computed correctly and the target does not change its course or speed. Therefore the firing data must be computed, and the guns must be loaded and laid so that they may be fired at a time ahead of 9:02 equal to the time of flight.

As the aerial observer is working under very adverse conditions and as his instruments, if he uses any besides his compass, are very crude, the probability is that his first report of the location of the target and its course and speed are none too accurate. However, that is the best we can do so we must try to adjust the track at the same time that we adjust fire. We know that the gun will not shoot so as to hit the point aimed at every time, but we have no way of determining the deviation of the shot from the point for which the data were computed. We must therefore throw this deviation, due to dispersion, into the deviation due to the error in locating the target correctly and assume that the observed deviation is due to the error in plotting alone. The gun is fired and the observer determines the deviation of the splash in terms of polar coordinates, using the clock system. The target is assumed to be at the center of the clock and to be traveling toward

12 o'clock. Or, in case of a stationary target, 12 o'clock is assumed to be magnetic north. To be universal it would perhaps be better to use the latter method. The deviation is sent to the plotting room. If the longitudinal and lateral deviations of the splash are computed and if the plotter plots the fall of the shot on the board but changes the sense, the point thus plotted would be a new plotted location of the target corrected by the amount of the observed deviation. Using this point and laying off a course parallel to the original course and using the same speed, a new setforward point is obtained which has been brought nearer to the actual position of the target. Actually, it is not necessary to determine the longitudinal and lateral deviations because, by placing the spotting protractor with its center on the point fired at and with its index (6 o'clock) pointing in the direction in which the target is traveling and marking a point through the small hole in the protractor at the same deviation reported by the observer, the new point is determined whose sense has automatically been changed. (If using magnetic north as 12 o'clock the index should be offset from 6 o'clock in the same manner as on the plotting protractor.)

This method is continued for two or three shots. The line joining the last two plotted target positions gives a closer approximation of the true course and their length and time interval being known, the true speed may be more closely determined. If after two or three shots the plotter finds that the shots are falling consistently behind the target it is a good indication that the reported speed is too slow and a slightly greater speed is used on the slide rule. If the shots are falling consistently over it is a good indication that the bearing of the course is in error and the plotter can alter the course so that the ranges will be decreasing. Full corrections are made and the course is adjusted on the plotting board each time until a bracket has been obtained with two successive shots after which adjustment corrections in percentages are made from reported deviations. The aerial observer should immediately notify the plotting room of any noticeable changes in the course or speed of the target.

The following is an example of typical data, with time in which it is believed that data can be gotten out. A longer or shorter predicting interval may be used as found necessary.

**OBSERVER'S REPORT**—Location X 1980—Y 2360; bearing 170; speed 15; time, 9:00. (Assumed that data are received at plotting room by 9:00:30.)

**PLOTTER'S REPORT** (If data are furnished other batteries.)—Target for 9:02 X 1960—Y 2300. (If data are for his own battery alone)—Data for 9:01:30 (assume time of flight of 30 seconds); range 18,000; azimuth 265.89. (The guns being previously loaded the data must be received and set so that they may be fired at 9:01:30.)

**OBSERVER'S REPORT OF DEVIATION**—1000 at 5 o'clock; time 9:02.

The plotter makes necessary corrections and locates new plotted point from which he determines new setforward point for time 9:04.

The time of splash sent in by the observer is the actual time it occurs. Should it differ from the time at which it was expected the plotter must use the actual time on which to base the time of the next setforward point. For example, if the splash occurred at 9:02:05 the assistant plotter would read opposite the 55-second graduation on the slide of his predicting-interval ruler to get the travel to the setforward point for time 9:05. If the splash had occurred at 9:01:50 he would read opposite the 10-second graduation to get the travel for time 9:04 or opposite the 70-second graduation to get the travel for time 9:05.

## Coast Artillery Noncommissioned and Warrant Officer Personnel

By CAPTAIN B. L. MILBURN  
*Coast Artillery Corps*

### *Replacement of Noncommissioned Officers on Foreign Service.*

Circular No. 1, War Department, January 8, 1926, institutes an important change in the method of replacing Coast Artillery noncommissioned officers on foreign service. The plan of replacement outlined in this circular was adopted by the War Department upon the recommendation of the Chief of Coast Artillery. It is understood that chiefs of other combatant branches are considering the adoption of a similar plan with reference to the replacement of noncommissioned officers of their branches.

The unsatisfactory conditions incident to the replacement of sergeants and first sergeants of Coast Artillery have for the past several years been the subject of frequent reports and studies. The system as laid down in Army Regulations 615-210 was not particularly at fault. The principal source of trouble was due to the large proportion of sergeants and first sergeants required in foreign garrisons. Of the 1038 sergeants authorized for the Coast Artillery Corps, 519, exactly one-half, are allotted to foreign garrisons, and of the 120 first sergeants authorized, 58 are allotted to foreign garrisons. This distribution at once suggests the importance and extent of the replacement problem. The supply of first sergeants and sergeants in the continental United States from which replacements were taken was further reduced through the operation of the following War Department policies in connection with the detail of enlisted men to foreign service.

- a. An enlisted man is not eligible for foreign service unless he has at least two years to serve in his current enlistment.
- b. He must have served or resided within the continental limits of the United States at least two years since completion of his last tour of foreign service.
- c. He must be reported by the medical officer as physically fit for tropical service.
- d. Noncommissioned officers on foreign service are frequently held until the arrival of their replacements. (The irregular and infrequent transport schedules make this a source of frequent delays.)

Due to the large proportion of first sergeants and sergeants in foreign garrisons and the operation of the policies referred to above, Coast Artillery organizations in the United States were securing such a frequent turn-over of noncommissioned officer personnel that serious interference with their training and a marked reduction in their efficiency were unavoidable results. It was not surprising also that the frequency with which noncommissioned officers were required to serve in foreign garrisons was a source of much personal hardship to them and their families and that the resultant dissatisfaction was causing many of them to leave the service or seek transfers to other branches. There were also many cases of first sergeants and sergeants asking reduction in order to avoid foreign duty. (No corporals are sent to foreign service in grade.)

Some sort of remedial action was therefore imperative. Several plans looking toward relief were studied and considered. As the principal source of difficulty with reference to replacements was due to the large number of first sergeants and

sergeants required for foreign garrisons, it was apparent that one of two remedies must be applied: either reduce the allotment of first sergeants and sergeants in foreign garrisons and increase the allotment in continental commands and thus provide a sufficiently large replacement pool in the latter to relieve their replacement requirements, or substitute a scheme whereby none or at least only a part of the first sergeants and sergeants in foreign garrisons would be replaced in grade upon completion of their tours of foreign service. The first remedy was dismissed as impracticable as it would leave organizations in foreign garrisons without sufficient noncommissioned officer personnel and a correspondingly unsatisfactory surplus in continental organizations. Although the second remedy appeared to be the only practicable solution, the method of applying it brought up several difficulties. It was clear that if the 519 sergeants on foreign service were not to be replaced in grade, most of them must be absorbed by continental commands, practically a 100 per cent absorption. This would work a distinct hardship upon organizations in the United States and suspend promotions for a period of several years. It was, therefore, decided to adopt the plan given in Circular 1, which provides that all first sergeants and sergeants appointed in foreign garrisons be reduced on their return to the United States and those sent to foreign garrisons as first sergeants or sergeants to be returned in those grades. The number to be absorbed under the former provision is reduced, of course, by the number returning for discharge. As much time as practicable was allowed for the returning first sergeants and sergeants to be absorbed in organizations to which assigned without necessitating the actual reduction of noncommissioned officers in these organizations. This period was necessarily limited, however, as it necessitated holding vacancies open in foreign garrisons due to the fact that the total number of noncommissioned officers authorized for the Coast Artillery Corps could not be exceeded at any time. (It was the desire of the Chief of Coast Artillery to secure a temporary increase of first sergeants and sergeants of the Coast Artillery Corps in order that the new replacement system could be established without requiring such a large number of sergeants to be absorbed. This could not be favorably considered, however, as it would require a decrease in noncommissioned personnel of other branches.)

The plan as adopted will require a considerable number of actual reductions. This is to be regretted. It was a case, however, of eliminating the more serious difficulties under the old system and it is believed that the new plan will operate as a whole in a very satisfactory manner. It will grant considerable relief to organizations in the United States and their sergeant personnel. It will give organization commanders the opportunity of appointing most of their own noncommissioned officers. This was denied under the old replacement system. Regulations provide that the first sergeants and sergeants of the regiment will be selected by the regimental commander upon recommendation of the battery commander. Local selection was not possible, however, under a system which transferred noncommissioned officers to and from foreign service without regard to the desires of the commanding officers concerned.

The new replacement system does not apply to enlisted specialists of the Coast Artillery (Electricians, Master Gunners, Sergeants Major, and Radio Sergeants). The appointment, assignment, and transfer of these noncommissioned officers are controlled by the Chief of Coast Artillery. Due to the fact that the number in each class in the continental United States exceeds the number in foreign garrisons no difficulty has been experienced in furnishing replacements for this class of personnel.

The following office policy has been adopted with reference to the detail of enlisted specialists to foreign service:

a. Noncommissioned officers of each class are placed on a separate foreign-service roster.

b. They are selected for detail to fill vacancies occurring in foreign garrisons in accordance with their standing on the roster, subject to the following conditions:

1. Noncommissioned staff officers who volunteer for foreign service may be sent ahead of their regular turn as authorized by Par. 4(b), A. R. 615-210, and as far as practicable their preferences for station will be followed.

2. Noncommissioned staff officers of the following classes are not eligible for tours of foreign service.

(a) Those who have not resided within the continental limits of the United States for two years since the completion of their last tour of foreign service. (Par. 4 (b) A. R. 615-210.)

(b) Those who are not physically fit for tropical service. A. R. 4 (c) 615-210.)

(c) Those who have less than two years to serve before retirement. (Noncommissioned officers of the first three grades who have less than two years to serve on current enlistment are no longer required to be discharged and reenlisted for the convenience of the government.)

(d) Those who are permanently assigned to the Coast Artillery School Detachment.

#### *Appointment of Enlisted Specialists.*

The situation with reference to enlisted specialist personnel is more favorable than it has been for some time. It is hoped to fill all existing vacancies by July 1 of the present year. The following table shows the present and prospective status of this personnel.

	<i>Electricians</i>	<i>Master Gunners</i>	<i>Sergeants Major</i>	<i>Radio Sergeants</i>
Vacancies, 4/15/26	30	0	1	0
Number on eligible list, 4/15/26	0	1	0	5
Estimated vacancies on 6/14/26 (a)	30	1	(c)	0
Graduates, 6/15/26 (b)	37	5	—	5
Remaining on eligible lists, 7/1/26	7	4	—	10
Estimated losses, fiscal year 1927	10	2	2	3
Remaining vacancies, 6/1/27	3	0	—	0
Remaining on eligible list, 6/1/27	0	2	—	

(a) Based on new reduced strength of noncommissioned staff. Proposed amendment to G. O. No. 19, W. D., 1923, will result in reducing enlisted specialists as follows:

Electricians	7	Master Gunners	5
Sergeants Major	2	Radio Sergeants	0

The following strength of the Coast Artillery noncommissioned staff will obtain after these reductions:

<i>Grades</i>		<i>Classes</i>	
Master Sergeants .....	88	Electricians .....	274
Technical Sergeants .....	89	Sergeants Major .....	100
Staff Sergeants .....	287	Master Gunners .....	40
	—	Radio Sergeants .....	50
Total .....	464		—
		Total .....	464

(b) Graduates of the Engineer, Artillery, and Radio Courses at the Coast Artillery School. Estimates based on 80 per cent of present classes.

(c) Depends upon number of successful candidates under competitive examination to be held in May. The applications of 22 candidates to take this examination have been approved by the Chief of Coast Artillery.

#### *Warrant Officers, Army Mine Planter Service.*

Each of the eight Army Mine Planters is authorized one master, one chief engineer, one first mate, one second mate, and one assistant engineer, making a total authorized strength of eight masters, eight chief engineers, eight first mates, eight second mates, and eight assistant engineers. No reserve is authorized to provide for temporary losses due to leaves of absence, sickness, travel upon change of station, and other causes. The replacement of warrant officers on foreign service especially requires mine planters in the United States to withstand extended losses of this nature.

Original appointments in the Army Mine Planter Service are now made only in the grades of second mate and assistant engineer. Appointments in the grades of master, chief engineer, and first mate are made by the promotion of the senior first mate, assistant engineer, and second mate, respectively. Upon the reduction of the number of army mine planters in 1922, it was necessary to discharge summarily a large number of warrant officers who had excellent records and who would otherwise have been retained in the service. For some time a policy was therefore pursued by which vacancies in all grades in the Mine Planter Service were filled by the reappointment of these discharged warrant officers. This policy had the effect, however, of denying promotion to first mates, assistant engineers, and second mates in active service and it was discontinued in 1924. Soon after this announcement Congress made provision for the remaining discharged warrant officers by authorizing their reappointment and immediate discharge or retirement.

The Marine Engineering and Deck courses at the Coast Artillery School were formerly the principal means of qualifying candidates as second mates and assistant engineers. Due to the large number of eligibles made available upon the reduction of the Mine Planter Warrant Officer strength in 1922 these nautical courses were suspended and have not been in operation since. Owing to the small number of eligibles required each year (probably not more than two or three in both branches of the Mine Planter Service) it is the present intention not to re-establish these courses as long as the present warrant officer strength obtains. To reopen the courses would require a faculty possibly as large as the student body itself and would require the purchase of additional equipment, including boats and other marine materiel and supplies. There is also a question as to whether the method of obtaining eligibles by theoretical courses alone is altogether satisfactory. It appears to be more feasible to select men for assistant engineers and second mates who are practical and experienced seamen, rather

than men who have successfully completed short periods of theoretical instruction. The policy has therefore been adopted to secure eligibles for these courses in the future through the medium of competitive examinations to be held from time to time as occasion may require. In selecting candidates to take these examinations preference will be given enlisted men of the Army Mine Planter Service. This policy has been adopted for two reasons. First, to encourage the enlisted men of the lower grades in the Army Mine Planter Service by offering opportunities for their advancement; and, second, to insure the appointment of practical seamen to the warrant officer grades.

Due to the fact that the present number of eligibles for appointment as second mate is sufficient to fill all prospective vacancies for the next four or five years, competitive examinations to secure eligibles for the second mate list will not be held within the next two or three years. The assistant engineer eligible list contained only three names, however, and a special examination was held for the purpose of securing additional eligibles for that list. The results of this examination have been reported. Of the ten applicants, six successfully passed the prescribed examination and the names of these men have been placed on the Assistant Engineer eligible list in the order of merit obtained in the examinations. The Assistant Engineer list now contains nine names and the Second Mate list five names.

Most of the enlisted men now on the warrant officer eligible lists graduated from the Nautical Courses at the Coast Artillery School in 1921. In the mean time they have had no practical experience or instruction on mine planters. A policy has been adopted to require these men to serve on mine planters as acting warrant officers approximately one year prior to their appointment. At the present time, for example, the enlisted men who stand number one on the second mate and assistant engineer eligible lists are assigned to duty as acting second mate and acting assistant engineer, respectively, on two of our mine planters. This experience will be invaluable in properly qualifying these men for duties as warrant officers. Commanding officers are required to submit efficiency reports on these men in the same manner as on the regular warrant officers. This serves the additional purpose of eliminating any of the present eligibles who, under actual conditions, do not appear to possess the necessary qualifications for appointment as warrant officers.

A new Army Regulation (A. R. 610-10) pertaining to Warrant Officers of the Army Mine Planter Service has been prepared and will soon be published to the service. A special need for such a regulation has existed for some time. Existing regulations pertaining to warrant officer personnel of the Army Mine Planter Service are covered in many different types of orders and instructions and in some cases administrative action is based upon precedent alone. The new regulations will bring all existing instructions under one cover (some of them with slight modification) and will reduce to definite and accessible form all approved policies and procedure with reference to this class of personnel. The new regulations will cover the following subjects:

*Appointment*, authorization, how made, when effective, basic requirements, eligible lists, lineal lists, competitive examinations, promotion examinations.

*Miscellaneous*, assignment, training and duties, efficiency reports, annual physical examinations, leaves of absence, pay and allowance, retirement, resignation, and discharge.

## A Fuze Range Percentage Corrector for Antiaircraft

LIEUT. J. E. REDERSON

*Coast Artillery Corps*

A range percentage corrector for antiaircraft is as necessary as is a range percentage corrector for heavy artillery (see T.R. 435-221). The writer has devised a fuze range percentage corrector which he believes will be entirely satisfactory. It consists of tables to be used with Bracket Fuze Setter, Model 1916, with a modification described below. It is based on the fact that range corrections vary directly with the range.

The Bracket Fuze Setter is modified by machining the housing cover so that its surface and radial distance for 1.4 inches on each side of the fuze range index is the same as for the latter. This surface is graduated in 0.1 units of fuze range (two graduations being equal to a 0.2 graduation between the 12 and 13 fuze range graduations on the range ring—the latter is equal to one graduation on corrector ring). The graduations are used as indices and when so used, give a range percentage correction (see Figs. 1 and 2). This is far more satisfactory than using the corrector ring, for the following reasons: (a) It allows the corrector ring to be used for adjustment corrections, (b) Less chance for error, (c) Corrections can be applied in far less time.

The tables of range-percentage corrections are computed for a certain gun, carriage, projectile, fuze, and trial shot point and therefore for altitudes within certain limits from the latter. The range percentage corrections are computed as follows:

a. Measure actual range to the intersection of each 0.5-unit fuze range curve, with a horizontal line through the T. S. point to be used (using trajectory chart).

b. With the actual ranges to all fuze ranges (in multiples of 0.5) at the same altitude as the T. S. point known, solve for C, in the following equation:  $\frac{R_1}{R_2} = \frac{C_1}{C_2}$

$C_1$  = Range percentage correction, in corrector divisions, for Range  $R_1$ .

$C_2$  = Range percentage correction, in corrector divisions, for Range  $R_2$ .

Example:

*Given:* T. S. point H = 2894 yds., B = 19, i = 600 mils, S = 408 mils, A. R. = 7700 yds; + 12 = Divisions of corrector necessary to bring the burst from its observed position into the inclined plane of position of the T. S. point (as computed from the T. S. problem).

*Required:* (a) The range percentage correction in 0.1 units of fuze range for B = 10.5.

(b) The index to be used for this correction.

*Solution:* (a) 5025 yds. = A. R. to B = 10.5 (see Table 2)

$$\frac{5025}{7700} = \frac{Cx}{12}$$

$Cx = +7.8$  or + 8 = Range percentage correction in .1 units of fuze range.

(b) 30 = Normal on range percentage correction index scale.

30 — 8 = 22 = Index to be used (see Fig. 2) to set correction 30; and add to 30 for a minus correction.

To find the index for a plus correction, subject the correction from 30; and add to 30 for a minus correction.

To find the range percentage correction and the index for any fuze and any T. S. corrector division correction by using Table "2," enter proper corrector division column and read range percentage correction and index for any fuze.

*Example:* *Given:* T. S. Corrector division correction of — 14.

*Required:* (a) The range percentage correction for B = 8;

(b) Index for the same.





TABLE II

Corr Div.	+ 15		+ 14		+ 13		+ 12		+ 11		+ 10		+ 9		+ 8		+ 7		+ 6		+ 5		+ 4		+ 3		+ 2		+ 1		0	
	B	A.R. R% C	I	R% C	I	R% C	I	R% C	I	R% C	I	R% C	I	R% C	I	R% C	I	R% C	I	R% C	I	R% C	I	R% C	I	R% C	I	R% C	I	R% C	I	R% C
2.0*	1280	2	28	2	28	2	28	2	28	2	28	2	28	1	29	1	29	1	29	1	29	1	29	1	29	0	30	0	30	0	30	
2.5*	1550	3	27	3	27	3	27	3	27	3	27	3	27	2	28	2	28	2	28	2	28	2	28	2	28	0	30	0	30	0	30	
3.0*	1820	4	26	4	26	4	26	4	26	4	26	4	26	2	28	2	28	2	28	2	28	2	28	2	28	0	30	0	30	0	30	
3.5*	2050	4	26	4	26	4	26	4	26	4	26	4	26	3	27	3	27	3	27	3	27	3	27	3	27	0	30	0	30	0	30	
4.0*	2300	5	25	5	25	5	25	5	25	5	25	5	25	3	27	3	27	3	27	3	27	3	27	3	27	0	30	0	30	0	30	
4.5*	2530	5	25	5	25	5	25	5	25	5	25	5	25	4	26	4	26	4	26	4	26	4	26	4	26	0	30	0	30	0	30	
5.0	2800	6	24	6	24	6	24	6	24	6	24	6	24	4	26	4	26	4	26	4	26	4	26	4	26	0	30	0	30	0	30	
5.5	3000	6	24	6	24	6	24	6	24	6	24	6	24	4	26	4	26	4	26	4	26	4	26	4	26	0	30	0	30	0	30	
6.0	3200	6	24	6	24	6	24	6	24	6	24	6	24	4	26	4	26	4	26	4	26	4	26	4	26	0	30	0	30	0	30	
6.5	3400	7	23	7	23	7	23	7	23	7	23	7	23	4	26	4	26	4	26	4	26	4	26	4	26	0	30	0	30	0	30	
7.0	3650	7	23	7	23	7	23	7	23	7	23	7	23	5	25	5	25	5	25	5	25	5	25	5	25	0	30	0	30	0	30	
7.5	3850	7	23	7	23	7	23	7	23	7	23	7	23	5	25	5	25	5	25	5	25	5	25	5	25	0	30	0	30	0	30	
8.0	4150	8	22	8	22	8	22	8	22	8	22	8	22	5	25	5	25	5	25	5	25	5	25	5	25	0	30	0	30	0	30	
8.5	4375	8	22	8	22	8	22	8	22	8	22	8	22	6	24	6	24	6	24	6	24	6	24	6	24	0	30	0	30	0	30	
9.0	4575	9	21	9	21	9	21	9	21	9	21	9	21	6	24	6	24	6	24	6	24	6	24	6	24	0	30	0	30	0	30	
9.5	4850	9	21	9	21	9	21	9	21	9	21	9	21	6	24	6	24	6	24	6	24	6	24	6	24	0	30	0	30	0	30	
10.0	4850	9	21	9	21	9	21	9	21	9	21	9	21	6	24	6	24	6	24	6	24	6	24	6	24	0	30	0	30	0	30	
10.5	5025	10	20	10	20	10	20	10	20	10	20	10	20	6	24	6	24	6	24	6	24	6	24	6	24	0	30	0	30	0	30	
11.0	5200	10	20	10	20	10	20	10	20	10	20	10	20	6	24	6	24	6	24	6	24	6	24	6	24	0	30	0	30	0	30	
11.5	5380	10	20	10	20	10	20	10	20	10	20	10	20	6	24	6	24	6	24	6	24	6	24	6	24	0	30	0	30	0	30	
12.0	5550	11	19	11	19	11	19	11	19	11	19	11	19	6	24	6	24	6	24	6	24	6	24	6	24	0	30	0	30	0	30	
12.5	5700	11	19	11	19	11	19	11	19	11	19	11	19	6	24	6	24	6	24	6	24	6	24	6	24	0	30	0	30	0	30	
13.0	5872	11	19	11	19	11	19	11	19	11	19	11	19	6	24	6	24	6	24	6	24	6	24	6	24	0	30	0	30	0	30	
13.5	6025	12	18	12	18	12	18	12	18	12	18	12	18	6	24	6	24	6	24	6	24	6	24	6	24	0	30	0	30	0	30	
14.0	6200	12	18	12	18	12	18	12	18	12	18	12	18	6	24	6	24	6	24	6	24	6	24	6	24	0	30	0	30	0	30	
14.5	6350	12	18	12	18	12	18	12	18	12	18	12	18	6	24	6	24	6	24	6	24	6	24	6	24	0	30	0	30	0	30	
15.0	6500	13	17	13	17	13	17	13	17	13	17	13	17	6	24	6	24	6	24	6	24	6	24	6	24	0	30	0	30	0	30	
15.5	6650	13	17	13	17	13	17	13	17	13	17	13	17	6	24	6	24	6	24	6	24	6	24	6	24	0	30	0	30	0	30	
16.0	6800	13	17	13	17	13	17	13	17	13	17	13	17	6	24	6	24	6	24	6	24	6	24	6	24	0	30	0	30	0	30	
16.5	6950	13	17	13	17	13	17	13	17	13	17	13	17	6	24	6	24	6	24	6	24	6	24	6	24	0	30	0	30	0	30	
17.0	7100	14	16	14	16	14	16	14	16	14	16	14	16	6	24	6	24	6	24	6	24	6	24	6	24	0	30	0	30	0	30	
17.5	7250	14	16	14	16	14	16	14	16	14	16	14	16	6	24	6	24	6	24	6	24	6	24	6	24	0	30	0	30	0	30	
18.0	7400	14	16	14	16	14	16	14	16	14	16	14	16	6	24	6	24	6	24	6	24	6	24	6	24	0	30	0	30	0	30	
18.5	7550	15	15	15	15	15	15	15	15	15	15	15	15	6	24	6	24	6	24	6	24	6	24	6	24	0	30	0	30	0	30	
19.0	7700	15	15	15	15	15	15	15	15	15	15	15	15	6	24	6	24	6	24	6	24	6	24	6	24	0	30	0	30	0	30	

\* Same as preceding table except that it has in addition the actual range and the range percentage correction (R% C), in corrector divisions, for each fuse.



*Housing, un modified*

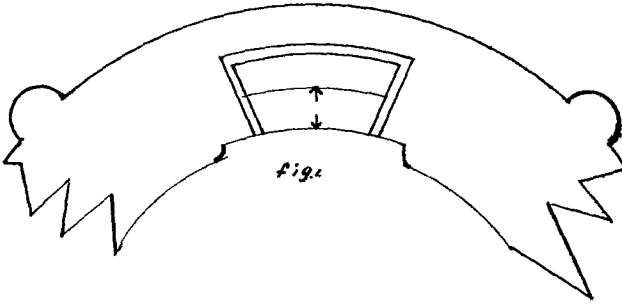

*Housing, Modified*

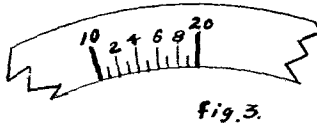
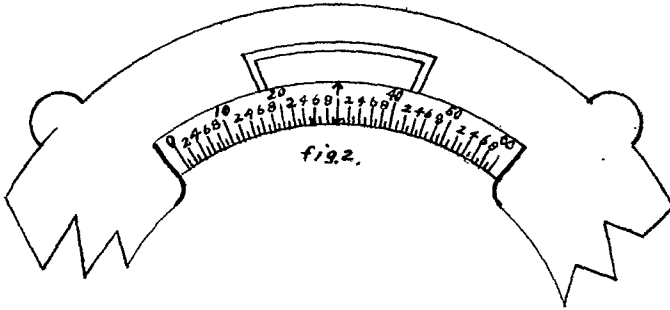

*Fuze Range curves 12.0, 12.2, 12.4, 12.6, 12.8, 13.0*

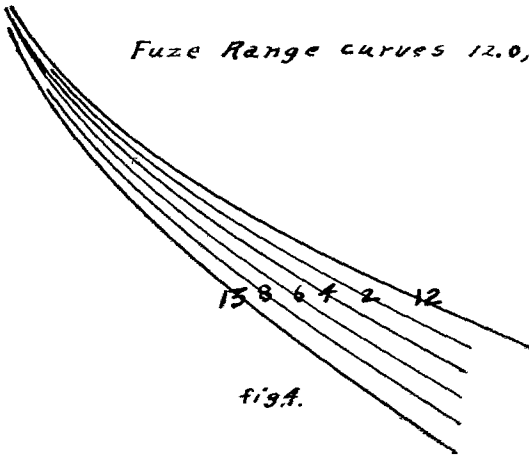

*Procedure:* Enter corrector column “-14” and read 8 and 38 respectively on the horizontal line for  $B = 8$ .

Table “1” is used in firing, as the index and fuze are adjacent and are all that are necessary to get the corrected fuze range, when set as subsequently described.

For target practices, tables for two T. S. points should be sufficient, namely:  $H = 1584$  yds.,  $B = 15$ ,  $i = 400$  mils,  $S = 258$  mils; and  $H = 2894$  yds.,  $B = 19$ ,  $i = 600$  mils,  $S = 408$  mils. For service firing, tables for 5000- and 8000-yd. altitudes should be computed.

To operate this range percentage corrector, a man, designated as a Range Percentage Reader, is added to the gun section. He takes post near the fuze setter and calls off the range percentage correction index to the Fuze Setter; an index called off will not be repeated for each fuze using this index, but only when the index changes. For example, if the T. S. corrector division is +15 and the first fuze received is “16.5,” he calls off “17”; the fuzes are decreasing and just after a fuze less than “14.8” is repeated by the Fuze Setter, the index “18” is called off by the Range Percentage Reader. The Fuze Setter should be informed by the Range Percentage Reader before the firing that the indices will either increase or decrease as the fuzes increase or decrease; for example, if the corrector division is +15 the indices increase as the fuzes decrease, while for a -15 corrector division the indices increase as the fuzes increase, and decrease as the fuzes decrease.

To enable the Fuze Setter to find the index instantly, the adjacent indices are of different lengths, and all even ones are numbered, except the “30,” which is normal. (See Figs. 2 and 3).

As the  $\Delta R$  for I corrector varies with the fuze range along any trajectory, and for the same fuze in different trajectories; it is necessary to apply arbitrary corrections, on the corrector ring, to correct for these variations so as to make Table I correct. As the  $i$  at any instant can be determined as explained in par. 4 on page 276, vol. 63, COAST ARTILLERY JOURNAL, the following corrections can easily be applied:

$\Delta$  CHANGE IN CORRECTOR RING SETTING FOR  $C = +5$   
(C being the T. S. Corrector)

$i$	$B$	Corrector ring correction
400 — 800	2 — 6	— 2
400 — 800	7 — 11	— 1
400 — 800	12 and above.	0
900 — 1500	2 — B for 4000 yd. H.	— 2

For  $C = -5$  the signs in column 3 are plus.

To realize the maximum results with the above method, it is recommended that wherever the interval between unit curves on the fuze range cylinder of the R. A. Corrector allows, 0.2-unit curves of fuze range should be drawn, and when this interval becomes impracticable to use all four of these 0.2-unit curves, the 0.4 and 0.6 curves only should be continued in the interval; these will eventually converge into one line (see Fig. 4). This will leave very little interpolation for the reader, thus avoiding error as well as saving time.

## Artillery Ordnance Development

*EDITOR'S NOTE.—The following notes were compiled in the office of the Chief of Coast Artillery by Major Oliver L. Spiller, C. A. C. Credit is accorded the monthly Digest of Activities of the Ordnance Department for much of the information contained herein.*

1. An intensive firing program, to be conducted by the 61st Coast Artillery at Aberdeen beginning September 1, is now being prepared by representatives of the Chief of Ordnance and the Chief of Coast Artillery. These firings will be in the nature of field tests of a great variety of anti-aircraft equipment including 3-inch guns, 37-mm. guns, .30 and .50-caliber machine guns, searchlights with distant control, and a searchlight and sound locator connected as a unit with data transmission device.

A great variety of fire-control instruments for use with both guns and machine guns will have their initial tests at these firings. Better facilities will be provided for accurate observation of the results of firing than have ever been available for firings conducted with anti-aircraft materiel.

2. Development work in the following lines has been conducted by the Ordnance Department during the past few months.

*a.* 240-MM. HOWITZER CARRIAGE, M. 1918, FOR EMPLACEMENTS WITH ALL-ROUND FIRE.—The traversing mechanism is to be modified on the carriages in the Hawaiian Department to install a quick release mechanism to permit rapid traverse when the change in azimuth is so large that it can not be accomplished promptly with the modified traversing mechanism recently designed for this set of carriages. The experimental triple-thread worm and worm wheel recently sent to Hawaii for test proved to be satisfactory for traversing on a rapidly moving target, but the quick release mechanism is desired for a quick change to another sector.

### *b.* ANTI-AIRCRAFT GUNS AND SEARCHLIGHTS.

(1) *Fire-Control Equipment.* A modification of the sound locator now in use has been completed at Frankford Arsenal and forwarded to Aberdeen for preliminary test. The modification consists principally of improvement in the means of elevating and traversing. The new apparatus is known as the exponential sound locator T-2.

(2) *Sighting Mechanism.* A modification of the sighting mechanism on the 3-inch Anti-aircraft Guns, M. 1917 and 1918, which is a great improvement over the old type is now being installed in all guns in service. The principal result of the modification is the elimination of practically all backlash. The sighting systems as modified will be known respectively as "Sight for Anti-aircraft Carriage M. 1917 A1" and "Sight for Anti-aircraft Carriage M. 1918 A1."

The sighting mechanism for the 3-inch anti-aircraft gun, M. 1917 ML, (for Panama) was examined by the Coast Artillery Board at Aberdeen in January last. Although the sight functioned very satisfactorily and was entirely acceptable to the representatives of the Chief of Coast Artillery and the Chief of Ordnance, it was later decided to modify this sight so as to eliminate the universal joint. Officers who are familiar with the various sighting mechanisms which have been produced since 1916 will be interested to learn that this sight, as it will be completed for the 1917 M1 gun, does not contain the universal joint for transmitting the vertical movement of the gun-pointer sight to the elements on the right side of the carriage. The change will not require any change in the R. A. Corrector for use with this materiel.

(3) *Concrete Mount for 3-inch Anti-aircraft Gun.* The War Department has approved a design of concrete emplacement for 3-inch trailer gun M. 1918,

and authorized its use for guns firing target practice and for guns mounted in defense areas in accordance with approved projects. This concrete platform was tried out at Fort Tilden last summer and greatly improved the stability of these mounts principally by eliminating the "whip" of the gun when going back into battery from recoil. As soon as funds can be made available it is intended to install a sufficient number of these for the conduct of target practice by all organizations which fire this materiel as their primary assignment. Unfortunately, it will be impracticable to do this in many places, due to the fact that target practice is conducted at places which are not on military reservations.

(4) *3-inch Antiaircraft Mount M. 1917 MI.* The firing of this materiel at Aberdeen was recently witnessed by representatives of the Coast Artillery Board and of the Office, Chief of Coast Artillery. This mount is intended for fixed emplacement in the Canal Zone. It is a very fine piece of work in which the elevating and traversing can be accomplished by a very slight touch on the handwheels. There is practically no backlash or lost motion in the mechanisms. The perfection which has been achieved in this materiel is very encouraging as it gives indication that similar results will be achieved in the production of the Mobile 3-inch Materiel.

(5) *Machine Guns and Mounts.* In continuation of the endeavor to supply suitable .30 and .50-caliber mounts, some modified types of the various tripods that have been in use for the past two or three years were demonstrated to the Coast Artillery Board during the past winter by a representative of the Infantry and Aircraft Armament Division of the Office, Chief of Ordnance. Five types of mounts were given tests in order that the Coast Artillery Board might make recommendations as to the perfection of two or more types for experimental work during the current year. The Board recommended manufacturing two of the improved mounts, for use with the .30 and .50-caliber machine gun. These mounts will be completed in time for extensive firing tests by the 61st Coast Artillery at Aberdeen in September.

(6) A design has also been initiated for the development of a mechanically geared mount for the .50-caliber machine gun which will be tested at Aberdeen at the same time.

(7) Consideration is also being given to mounting either the .30 or .50-caliber, or both, in multiple, with the idea of firing them simultaneously.

(8) *Machine Gun Fire-Control Apparatus.* One of the most vital problems in the development of antiaircraft materiel is that which concerns proper fire-control equipment for use with machine guns. Considerable progress has been made in the development of a sight but the development of some means of obtaining the data necessary for setting this sight is far behind the rest of the program. It is generally believed that there should be some simple means of rapidly determining the speed or altitude of the airplane with sufficient accuracy to permit the gun to be laid by the setting of this single element of data on the sight.

A 50-cm. stereoscopic range finder has been furnished the Coast Artillery Board for test to determine its suitability for use with machine gun units.

Consideration is also being given to a coincidence type of range finder to determine its suitability for this purpose.

### c. AMMUNITION.

The Ordnance Department is continuing the work which has been in progress for some time to secure better destructive effect from the antiaircraft projectile by increasing the efficiency of the fragmentation. Much improvement has been made

over the types of 3-inch projectiles now in service and it is expected that the destructive volume of the projectile will be greatly increased by the development which is now being made in this line.

(1) When the Mark III Scovil Fuze was adopted for standard for the 3-inch gun last fall, the Ordnance Department was interested in providing fuze covers from the stocks on hand. It was found that the M. 1907 time and percussion fuze cover could be made to fit the MIII fuze by simple re-sizing process to be made at Picatinny Arsenal. This type of cover is now being supplied for use with the MIII fuzes.

(2) In an effort to determine as nearly as possible the extent which tracer bullets, as so far developed, may be expected to be used in anti-aircraft machine gun fire direction, a program of investigation is being conducted at the Aberdeen Proving Ground. It is expected that considerable data will be obtained to show the relation between the trajectory of the tracer and the service bullets and also give an idea as to how far out on the trajectory the tracer ceases to burn.

### 3. MISCELLANEOUS.

a. *Cross Country Car.* The consideration of the communication requirements of the various branches resulted in action by the Ordnance Department to procure one Chevrolet cross-country car for test by the Field Artillery Board and one for test by the Infantry Board. Two Ford cross-country cars have been procured and issued to the 1st Cavalry Division. One of the Ford cars is equipped with windshield and the other without windshield, the idea being to secure comparative data on this particular feature.

b. *Long-Range Firing Program.* The long-range firing program that was to have been conducted at Fort Tilden and Fort Hancock this summer in accordance with the program prepared by the Coast Artillery Board will not be conducted this year. This decision was made by the War Department after study of the various activities to be carried on in the Second Corps Area this year.

## Foreign Periodicals

REVUE DES DEUX MONDES, January, 1926. *General View of the Affairs in Northern Morocco during the Year 1925.*—The Spanish Military Journal, *La Guerra y Su Preparacion*, publishes a translation of this interesting article in its issue of March, 1926. It is practically a summary of the operations in Northern Africa during the last year, giving in detail the difficulties under which war operations are being conducted. Abd-el-Krim is a capable and energetic leader, who has succeeded in organizing a capable staff, foremost among whom is Si-Mohamed-Abd-el-Krim, a brother of the Riffian leader, who has repeatedly shown real military qualities. Marshal Lyautey, who had been in charge of Morocco for so many years and who rendered such valuable services during the Great War, was relieved by Marshal Petain on July 16, 1925, and the first step taken by the latter was to come to an understanding with the Spanish dictator with a view to closer cooperation between the Spanish and the French. The Spanish landing at Alhucemas and the capture of Axdir seem to give proof that such cooperation is an actual fact. Abd-el-Krim's army is composed of about 120,000 tribesmen, well acquainted with the country and well versed in guerilla warfare. They have suffered defeats at the hands of the French and the Spaniards in recent encounters, but the pacification task is not at an end by any means. A map of Northern Morocco enables the reader to follow the narration of events and helps to form a clear conception of the conduct of operations in Northern Africa.—E. M. B.

REVUE DE PARIS, February, 1926. *The Military Role of Aviation in Morocco*, by General A. Niessel, French Army.—In this interesting article, General Niessel explains the true role of aviation in Morocco, and enumerates in detail the difficulties that are encountered in Northern Africa. The materiel received from France comes disassembled and must be assembled and placed in readiness in Morocco. This work is done at Casablanca, although the park at Ouran handles all the equipment used in Eastern Morocco. Climatic conditions, lack of facilities and war conditions greatly shorten the life of airplanes. Up to the present moment, the role of aviation has been bombardment, reconnaissance, observation, and photography. There has not been any night bombardment work because there are no objectives such as large cities, railway depots, or factories. The types of planes used are the Breguet 14A2, which is normally an observation plane but which is also used as light bombardment plane, and the Hanriot 14, used for liaison work and also as ambulance plane. The author believes that too much has been expected from aviation, and he concludes his article by stating that aviation is a most essential means, but that it cannot, by itself, win the war in Morocco. Its work in Africa, just as anywhere else, must be to work in cooperation with the other arms of the service for the successful achievement of the common aim.—E. M. B.

RIVISTA DI ARTIGLIERIA E GENIO, March, 1926. *Contribution to the Study of Variable Charges in Field Artillery*, by Lieutenant Colonel Cesare Cerutti, Italian Artillery.—The author states that the last war has shown the desirability of employing variable charges in field guns. The necessity of using fixed ammunition has rendered the solution difficult, but such a solution is now described by the author as follows: a cartridge case with a movable base assembled by elastic expansion. The case is practically a tube united at one end to the projectile and having an extraction rim at the other. The movable base is cup-shaped and fits into the rear end of the case by elastic expansion. This base not only closes the end of the case but also acts as an obturator by elastic expansion to prevent the escape of the powder gases.

The variable charge consists of a number of elements all equal in form and weight and any charge is specified by the number of elements it is to contain. By this system and suitably fashioning the movable base the charges will always be formed of the same powder and same granulation and the density of loading will not be altered since the volume of the powder chamber will be regulated by means of the proper movable base.

For the 75-mm., six charges are assumed beginning with one element of .60 Kg. and increasing by a like weight for each successive charge, the corresponding velocities being 135, 225, 290, 355, 410, and 460 meters per second.—F. E. H.

REVISTA DEL EJERCITO Y DE LA MARINA, November, 1925. *Foreign Military Missions in Latin America*.—At present, almost all the Latin American republics have European military commissions who are in charge of the reorganization of the military forces. The army of Chile is being modernized by the Germans, Peru and Brazil by the French, San Salvador by the Spaniards, Ecuador by the Italians, and Colombia has just signed a contract with a Swiss military commission. French officers are instructors in the "Escuela Militar de Aplicacion" of Mexico. These military missions have a decided influence on public opinion, they inculcate European ideas in the minds of the South American officers. The article is short, but gives a good idea of the present state of military affairs of the New World.—E. M. B.

### Remington's New Rifle

About the middle of July Remington will bring out an American bolt action rifle for use in the game fields, which will be a decided improvement over any arm of this type ever produced anywhere. We believe readers will be interested in this new sporting arm and give some of its specifications.

*Calibers*—.25 Remington rimless, .30 Remington rimless, .32 Remington rimless, .35 Remington rimless, .30'06 Springfield rimless. *Length, over all*—42 $\frac{3}{4}$



inches. *Weight*—About 7 $\frac{1}{4}$  pounds. *Barrel*—Ordnance steel, 22-inch. *Buttstock and Forestock*—American walnut, in one piece, pistol grip, forestock and grip checkered, fitted with loops for sling straps. *Sight*—Front sight is gold bead of blade type, buckhorn sporting rear sight with adjustable, reversible leaf with U. and V. notches and adjustable slide. *Magazine*—Staggered, box type; charged singly or from standard clip; capacity, five cartridges.

#### T. R. 435-184: "Service of the Piece, 155-mm. G. P. F. Gun"

T. R. 435-184: "Service of the Piece, 155-mm. G. P. F. Gun," has been eliminated from the Coast Artillery list of Training Regulations, and work on this regulation has been discontinued.

T. R. 430-30: "Service of the Piece, 155-mm. G. P. F. Gun," is now being prepared by the Field Artillery and will be published at an early date. This regulation will be used by all Coast Artillery units assigned to 155-mm. guns for drill and practice.

#### A Correction

In the figure given on page 336 of the JOURNAL for April, 1926, illustrating the article, "A Graphical Solution of the Trial Shot Problem" by Captain B. F. Harmon, an error was made which, if undiscovered, would cause much confusion to anyone making a study of the article. The draftsman preparing the plate displaced the scale of coordinates on the left-hand side of the figure downwards fifty yards, making all points in the figure read fifty yards too high. For example, the line marked 4200 should read 4150. The JOURNAL regrets the error and hopes it has not caused undue confusion.

# MILITARY NOTES

---

## Japan

**MILITARY TRAINING OF YOUTHS.**—One of the most important events that has taken place in Japan in recent years is the institution of military training of youths, not only those who are enrolled in schools but extended to include those who are not so fortunate as to have the advantage of higher intellectual education.

The military training recently made compulsory for all youths in middle schools and universities under the jurisdiction of the Department of Education is modeled along the general lines of our own R. O. T. C. system. The original act provided that training in normal schools, all government and private middle schools, government and private technical schools, high schools, preparatory schools and colleges should be obligatory.

In all, there are 1164 schools where military training is given, and, to date, all but thirty of these schools have been provided with active army officers as instructors. The total number of students now undergoing military training may be taken as 475,000.

The instructor personnel are selected from the active army list from the grade of first lieutenant to colonel. On December 2, 1925, officers were detailed on this duty as follows:

Colonels, 20; Lieutenant Colonels, 47; Majors, 241; Captains, 682; Lieutenants, 124. Total, 1114.

In addition, there are a large number of reserve officers employed directly by the various schools.

The courses of training, schedules, etc., are decided upon by mutual arrangement between the War Department and the Department of Education. Two or three hours per week in the case of middle schools, and at least one and a half hours per week in the case of higher schools, are devoted to training. Four to six days every year will be spent in field training.

Investigation having shown that a great mass of the young Japanese receive only elementary school education, it was then decided to extend military training to this class estimated to number one million five hundred thousand annually. While this class of training is to be entirely voluntary, whoever refuses to enroll does so at the risk of remaining in conscriptional training for the full specified term.

This training not-in-schools is to consist of eight hundred hours during a four-year period, as follows:

Ethics and citizenship	100 hours
Elementary education	200 hours
Business Training	100 hours
Military drill	400 hours

The undertaking, being entirely national, will be placed under the direction of the local mayor or village chief. The schoolmasters, usually military reservists, will act as instructors. The War Department is responsible for the supply of

arms and other necessary equipment as well as the inspection of the results attained. As can readily be seen, it is, in a way, an adaptation of many of the features of our C. M. T. C. system.

Perhaps the army alone realizes the full significance of the new system. Military training is extended to two million young men, the great majority of whom would not have received it otherwise, thus increasing to a marked degree the efficiency of the Japanese Army. The national physique will be greatly improved; the army and navy will regain its old place in the affections of the people; there will be a general get-together in national thought and ideas.

Undoubtedly the new system means a marked increase in Japan's military power accomplished at a minimum of expense either to the nation or to the individual.

## Italy

REORGANIZATION OF THE ITALIAN ARMY.—The important Army Reform Bill for the reorganization of the Italian Army became a law on March 15, 1926, on which date it was signed by the king. The following summary of the principal provisions of the new law should prove of interest to the military student.

Of the three Fighting Services the Army is the most important.

It is essential to provide for the rapid mobilization of all the resources of the State, and particularly for the rapid mobilization and assembly of the Army.

In spite of the greatly increased power of mechanical contrivances, it is still the human element, the soldier, that counts for most in war. In fact, the greater the improvement in mechanical contrivances, the higher must be the qualities of the men who are to use them or to oppose them.

One annual contingent produces a total of about 230,000 physically fit men, of whom, however, about 30,000 may be exempt. One-quarter of the remainder may also be dismissed after a reduced term of service of not less than six months. The budget strength of the Army may be taken as 220,000.

The minimum strength of the Army is fixed at 150,000, which figure will be adhered to in the non-training season, that is, during the winter months. During the training season, *i. e.*, in the summer months, two annual contingents will overlap. (According to a statement made by General Cavallero the actual strength during the training season will amount to about 325,000 and the average net yield of a levy as 200,000 men.)

The land forces will be organized into 4 Armies, 10 Army Corps and 29 divisions, plus the special and more or less independent commands of Sicily (1 Army Corps), and of Sardinia (1 division). For the immediate protection of the frontiers, the Alpini will be formed into 3 brigades, each of 3 regiments (total 27 battalions). They will be kept in a state of constant readiness, and each brigade will have its own regiment of mountain artillery with 9 batteries (total 27 mountain batteries). The Alpini brigades will thus be organized on the ternary principle in the same way as the brigades of ordinary divisions, but they will differ from the latter in that their component parts will be more widely distributed and decentralized. They will be able to take the field immediately, and can be supported at short notice by certain divisions whose peace strength will be above the average.

Since the Great War divisions in the Italian Army have nominally comprised 2 brigades of infantry, each of two regiments, each of three battalions, or 12 battalions in all; one regiment of field artillery, besides other troops, was allotted to each division; but in actual fact divisions existed in little more than name and

could not be regarded as organized formations. Under the provisions of the present bill the above composition of divisions will be abandoned, and in its place the "Divisione Ternaria" comprising only 1 infantry brigade of three regiments (total 9 battalions), with 1 regiment of field artillery (12 batteries) and other troops, will be introduced. The *Divisione Ternaria* is to be regarded as the key-stone of the new organization, and is to become a self-contained tactical unit.

The existing total number of divisions (30) and of Army Corps (10) will remain, but they will be differently grouped. The Palermo Army Corps (the 10th) allotted to the island of Sicily will be abolished as such; a New Army Corps on the Continent of Italy will be created, and the two islands of Sicily and Sardinia will become separate "Island Military Commands." In this way it will be possible to effect improvements in the conformation of Army Corps areas on the land and sea frontiers, and to reduce some of those areas whose great extent and awkward shape has hitherto caused inconvenience. Divisions will differ in strength, according to the areas in which they are located.

The period of military service will continue to be 18 months for all male citizens, excepting a very small percentage who may be entirely exempted for family reasons by the Minister for War.

In order to insure that supplies of war material and mobilization equipment are always maintained in sufficient quantities and in good condition, special Mobilization Inspectorates will be created. These are entirely new institutions and will number 30.

With respect to individual arms and services, the following points are brought to notice:

*Infantry.* The reorganization of the infantry will entail a reduction in the number of regiments from 104 to 90. All regiments will shortly be provided with more modern arms.

*Bersaglieri.* All Bersaglieri (12 regiments) will be converted into cyclist machine-gun units.

*Artillery.* The field artillery will be increased from 27 to 30 regiments so as to provide one regiment for each divisions.

The heavy field artillery will be reduced from 14 regiments to 11, so as to coincide with the number of Army Corps.

The heavy and coast artillery (hitherto united), will be separated, in order to form two distinct branches.

The anti-aircraft artillery will be reorganized and more suitably distributed.

*Engineers.* The engineers will remain practically unaltered; only a slight increase will be made in wireless-telegraphy specialists.

*Tanks.* Tanks will remain an independent body, but they will be so organized as to allow for future developments.

*Administrative Services.* The Administrative Services will on the whole be reduced and simplified, and efforts will be made to unify certain services that are common to the army, navy and air force. (Unification has already taken place in the Chemical Warfare Service, in the Intelligence Service, and also to some extent in the Commissariat Service.)

*Permanent Staff.* With respect to the Permanent Staff (*i. e.*, the officers and under-officers known collectively as the "*quadri*"), it is pointed out that the new bill will not cause any great change in numbers, and that their prospects will be improved. Great reliance will continue to be placed in "Complement Officers," and it is intended that all youths with the necessary qualifications shall annually perform their military service as officers.



ESTHONIAN CAVALRY PASSING IN REVIEW  
EQUIPMENT: ROSS-ENFIELD AND LANCES



ESTHONIAN ARTILLERY (GERMAN TYPE HOWITZER)

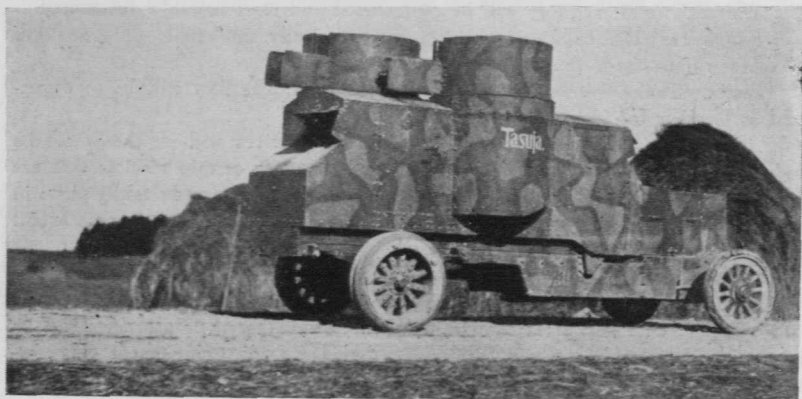

ESTHONIAN ARMORED AUTO (2 MACHINE GUNS)



ESTHONIAN INFANTRY MACHINE GUN SQUAD  
GERMAN MAXIM; ROSS-ENFIELD RIFLE



ESTHONIAN ARTILLERY (18-POUNDER)



ESTHONIAN INFANTRY ARMED WITH RUSSIAN 3-LINE RIFLES

# COAST ARTILLERY BOARD NOTES

*Communications relating to the development or improvement in methods or materiel for the Coast Artillery will be welcome from any member of the Corps or of the Service at large. These communications, with models or drawings of devices proposed, may be sent direct to the Coast Artillery Board, Fort Monroe, Virginia, and will receive careful consideration. R. S. ABERNETHY, Colonel, Coast Artillery Corps, President Coast Artillery Board.*

---

## Projects Initiated During the Month of May

*Project No. 463, Test of Sighting Equipment for Altimeters, Model 1920.*—Complete lighting equipment for anti-aircraft altimeters, Model 1920, has been designed and constructed by the Ordnance Department as a result of recommendations in Coast Artillery Board Project No. 252. One set of this equipment was sent to the Coast Artillery Board for test and report to the Chief of Coast Artillery.

*Project No. 464, Test of Telescopic Sight, Model 1923.*—The telescopic sight, Model 1923, which was built for the 14-inch railway gun, model 1920, is believed by the Ordnance Department to possess characteristics which are superior to those of the Model 1912 or 1912 MI telescopic sights. One of these Model 1923 sights has been sent to the Coast Artillery for assembling to one of the fixed seacoast artillery carriages to determine whether or not this sight is more satisfactory than those now in use.

*Project No. 465, Firing Tables for 3-inch A.A. Gun, Model 1917—1917 MI—1917 MII and 1925 MI.*—These tables prepared by the Ordnance Department were arranged partially in the way recommended by the Coast Artillery Board in Project No. 382. After study, the Board recommended that all of the changes recommended in Project No. 382 be incorporated in the tables examined in this Project.

*Project No. 466, Test of Illuminating System (Homelite) for Mobile Artillery Units.*—A complete lighting system has been purchased by the Ordnance Department for test by the Coast Artillery Board. The object of this test will be to determine whether the system will be suitable for use with the 155-mm. materiel, including illumination of the vicinity of guns and plotting room. The essential part of this system is a 12-volt Homelite gasoline generator battery charging set.

*Project No. 467, Propelling Charges for 12-inch Mortars, Model 1912 (Battery Barlow, Fort MacArthur, Cal.)*—In order to complete the War Reserve ammunition allowance of propelling charges for the 12-inch mortars, Model 1912, in the harbor defenses of Los Angeles the District Commander, 9th Coast Artillery District, has recommended that charges be constructed by utilizing a large quantity of bulk powder now in storage at Fort McDowell. This recommendation was referred to the Board for study.

## 44/ Completed Projects

### *Project No. 411, Test of Adamson Antiaircraft Machine Gun Sight*

#### I—HISTORY OF THE PROJECT.

1. An antiaircraft machine gun sight having a movable front sight, with rings representing speeds and radii representing angles of approach, all of which were kept in a horizontal plane by a pendulum, was designed by Captain E. H. Taliaferro, C. A. C. This sight was elaborated by Major K. F. Adamson, Ordnance Department, into the present Adamson sight as pictured in Fig. 1. The front sight is a circular grid having a center and two concentric circles and eight equally spaced radii representing angles of approach. The axis of this grid is supported on trunnions and at the right-hand end has a pendulum to keep the grid horizontal as the gun is elevated. This lead pendulum is, in form, a quadrant of a circle, and under it is a quadrant which elevates with the gun and is equally spaced in three colors, red, yellow, and green, corresponding to angles of elevation of 0 to 30 degrees, 30 to 60 degrees, and 60 to 90 degrees, respectively. All parts above described are supported by an arm at right angles to axis of gun bore and free to move in a vertical plane both perpendicular to and parallel to bore axis.

2. This arm moves in a vertical plane over the face of a platen 25 inches by 8 inches which bears curves of constant speed, thirteen curves representing speeds from 40 to 160 miles per hour, each curve having range points thereon. The ranges are marked in hundreds of yards, usually from 4 to 18. On this platen below the curves of constant speed are three sets of curves for ranges, each set having a curve for ranges 8, 10, 12, 14, 16, and 18. One set of curves—the uppermost—is green in color; next below is a yellow set, then a red set, each set corresponding to the angles of elevation represented by the colored arcs below the pendulum. The sight arm has three index notches, one for each set of range curves.

3. To operate the sight the gun is pointed on the target, and the sight arm (by means of a handwheel and set of gears) is set at the measured range on the proper speed curve. By means of another handwheel or knurled knob and gearing, the sight arm is raised or lowered so that one of the notch indices is set on the proper range curve of the green, yellow, or red set of curves, according to which color is indicated by the pendulum. The gunner so points his gun to put the target on the front sight radial wire corresponding to the proper angle of approach, at its intersection with the outer concentric circle (if target is "coming") or the inner circle (if target is "going") and keeps the target on the radial line until it reaches the other circle when the gun is aimed again at original point. A bead rear sight is used.

4. The Adamson sight as received here had a twisted strand copper wire to operate the sight arm over the face of the platen. This wire stretched and broke so much that the first firing test was unsatisfactory. In the Coast Artillery School machine shop a system of gearing and a helical screw was installed which performs this function much more satisfactorily.

5. To use altitude instead of ranges there was placed on the pendulum arc, above the platen, a xylonite plate bearing range curves, plotted with angular height and altitude as arguments, and an index pointer arm was attached to the sight arm so as to slide up and down the sight arm over a series of altitude graduations. By setting this index pointer at proper altitude and pointing the

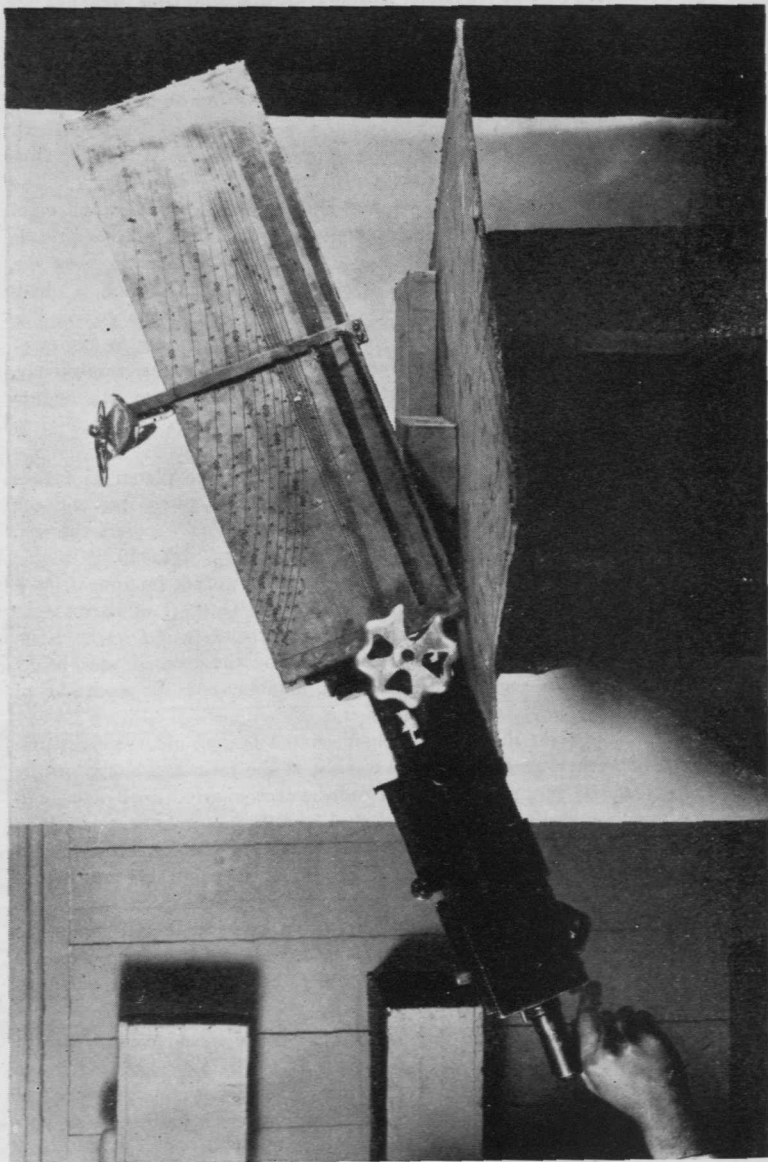

FIG. 1

gun at the target to get proper angular height, the slant range is read on the scale on the pendulum arc.

6. After installation of the gearing the sight was tested again on one gun of Battery E, 61st Coast Artillery (A.A.) during one of their firings upon sleeve targets.

## II—DISCUSSION.

7. The Adamson sight permits the setting of all the elements required for delivering of anti-aircraft machine gun fire, vertical and lateral deflection being varied by the adjustable distance between front and rear sights. Angle of approach must be estimated to the nearest 45 degrees; speed of target must be estimated or measured to nearest 10 miles per hour; slant ranges must be measured and can be set on even hundreds of yards or, by interpolating, to as close as ten or twenty yards; superelevation is changed for every two hundred yards range and amount of change depends upon angle of elevation.

8. Increased accuracy would result if more groups of range curves were used to obtain superelevation—a group for, say, each ten degrees elevation, but the increased accuracy would be slight, the difficulty of operation increased, and the size of platen, hence bulk and weight, greatly increased.

9. The curves placed on the pendulum to be read when altitude is known could be on a pendulum placed elsewhere with a pointer to be set at proper altitude. The advantage of such an addition is that if an altitude can once be obtained and sent to the gun, data can be set continuously without further data from outside source so long as the target maintains the same altitude. This is not true of a diving target nor necessarily so of any machine gun target, but in any case, altitudes will never change so rapidly as ranges. Data transmission to all the machine guns of a battery will always be subject to interruption, but, if one altitude reading gets to the gun, the gun can function. The diving target will be exceptional. Ground troops being subjected to diving attack by airplanes can offer their own defense. The anti-aircraft machine guns, particularly the .50-caliber guns, will usually find their targets en route to an attack or other mission or while diving at some other objective. In many cases a knowledge of altitude alone will suffice for the Adamson sight to function if the sight be equipped with the range altitude curves.

10. Errors in estimation of speed as small as 10 miles per hour equal errors in range of from 100 to 200 yards.

11. The sight as now constructed is too stiff and difficult of operation. The scale on the platen is large and the time taken to set the sight at proper speed curve is excessive. Pendulum should be heavier and the front sight so swung as to give better balance. The entire apparatus is very heavy and adds considerably to machine gun weight. It is not sufficiently easy to install and remove to be suitable for transportation separately, and it has protruding parts liable to breakage if transported on the gun.

12. It might be possible to reduce the scale of the speed curves by, say, one-half, thereby reducing bulk of platen. To do this, however, additional gearing would be necessary so that a movement of the sight pointer of one inch would move the sight two inches.

## III—CONCLUSIONS.

13. A satisfactory machine gun sight must have means by which (a) slant range (or altitude), (b) superelevation, (c) vertical deflection, and (d) lateral

deflections can be quickly applied. The sight should be rugged, yet not of such bulk as greatly to increase the total weight of the gun. This question of weight is not so important on an artillery type mount for a .50-caliber weapon, but it is important for a .30-caliber weapon, the mobility of which is an important feature. The data necessary for (a), (b), (c), and (d) above need not all be applied directly; as much as possible of it should be computed and set automatically at the gun, *e. g.*, by setting slant range or altitude and pointing the gun at the target, a means of having the superelevation set itself automatically is possible.

14. The difficulties attending position-finding instruments for antiaircraft machine gun work, sufficiently accurate, mobile, and capable of rapid determination of data and the transmission of such data from instruments to machine guns, must be considered along with the sight design. Determination of data to a high degree of accuracy is unnecessary if means of properly applying same on the gun and means of accurate pointing and following with the gun are inaccurate or based on estimation. Likewise extreme accuracy in pointing is unnecessary if there is not developed efficient means by which ranges (or altitudes), speed, etc., can be determined and transmitted to the gun.

15. The Adamson sight has means of setting speed of target with more accuracy than can reasonably be expected in determination. Ranges can be set with an accuracy greater than that to be expected from range instruments. Angle of approach can be set to nearest 45 degrees, less than the accuracy which could be in the measuring, even the estimation of the same.

16. To include a range scale that can be read by setting altitude when gun inclination gives angular height would be advantageous.

17. The present model of the Adamson sight is too heavy and data is set thereon with insufficient facility due to crudeness of construction. It is not practicable to conduct satisfactory firing tests for the purpose of determining relative accuracy with the present model. Also, means of measuring ranges efficient enough to give fair test to the sight have not been available to date.

18. A rear sight of clover leaf design would give best field of view and accuracy in aiming.

#### IV—RECOMMENDATIONS.

19. The Coast Artillery Board recommends:

*a.* That the present model Adamson sight be sent to Frankford Arsenal and that a new model be constructed having following features:

- (1) Of lighter material, such as duralumin or aluminum.
- (2) Of lesser bulk if redesign shows this possible.
- (3) Geared to permit ease in setting sight arm.
- (4) To include a range scale that can be read when altitude is known.
- (5) With a rear sight of clover leaf design.

*b.* That the new model be sent to the Coast Artillery Board for test.

#### V—ACTION OF CHIEF OF COAST ARTILLERY.

473.85/W-2

1st Ind.

War Department, O. C. C. A., May 6, 1926—To Chief of Ordnance.

1. Proceedings of the Coast Artillery Board on Project No. 441 are enclosed herewith, one copy of which may be retained for your file.

2. The conclusions and recommendations of the Board are, in general, concurred in. Due to the importance which certain parts of the discussion have been

when considering the requirements of a sight for anti-aircraft machine guns, it is desired to invite attention to certain points in that discussion.

Paragraph 13.—The sight should have means for quickly applying the data: (a) Slant range (or altitude); (b) Super-elevation; (c) Vertical deflection; (d) Lateral deflection. It is believed that the only element of data to be applied directly on the sight is (a). All the other elements should be indirectly (automatically) applied during the operations or laying and pointing the gun.

Paragraph 14.—It is obvious that it is a needless waste to provide in a sight great refinement, involving scales for accurate setting of elements of data when no accurate means for determining those elements are provided. Nevertheless, at this stage in the development of sights and fire-control apparatus, efforts should be directed towards securing the greatest accuracy possible. The development work thus far carried on to produce accurate fire-control instruments for anti-aircraft machine guns has been entirely too limited to give any definite indication as to the possibilities of the outcome.

Paragraph 19.—The recommendation made in subparagraph *b*, paragraph 19, is modified as follows: That the new model be constructed from the present model of the Adamson Sight, as outlined in subparagraph *a*, paragraph 19, be completed in time for test by the 61st Coast Artillery at Aberdeen in September.

3. It is requested that this office be notified as to whether or not it will be practicable to furnish the new model in time for the tests at Aberdeen.

<sup>460</sup>  
Project No. ~~450~~, *Number Strips and Prediction Scales for Cloke  
Plotting and Relocating Board*

I—HISTORY OF THE PROJECT.

1. Letters, dated April 6, 1926, from the Chief of Ordnance to the Chief of Coast Artillery on the subjects of "Cloke Plotting and Relocating Boards" and "Prediction Scales," and the 1st Indorsement to each of these letters are as follows:

1. Cloke boards issued to the service are equipped with sets of replaceable number strips graduated as follows:

<i>Yards per inch</i>	<i>Maximum range</i>
300	11,400
600	22,800
750	28,500
1500	57,000

2. Steps are being taken to supply sets of number strips graduated 900 and 1200 yards to the inch for use with the Cloke Board assigned to the 14-inch Gun Railway Mount at Fort MacArthur (O. O. 413.683/319—O. C. C. A. 413.6813/14B).

3. Information is requested, if available, at this date, as to the number and scales of strips to be issued with each Cloke Board in the future, noting that it may be desirable to vary the strips to suit the armament served.

413.6813/V  
1st Ind.  
War Department, O. C. C. A., April 10, 1926—To President, Coast Artillery Board, Ft. Monroe, Va. (Through Commandant, C. A. School).

For remark concerning the information requested in paragraph 3, basic letter.

1. In connection with a letter from this office under the same date on the subject of proper number strips to be issued with Cloke Plotting and

Relocating Boards, information is requested as to the manufacture and issue of prediction scales to suit the scales in use on the plotting boards.

2. The Cloke boards issued to the service have been equipped with scales graduated 300, 600, 750 and 1500 yards per inch, and, in one case, arrangements are being made to issue scales graduated 900 and 1200 yards to the inch. This latter issue is for the 14-inch Gun Railway Mount at Fort MacArthur. (O. O. 413.683/319—O. C. C. A. 413.6813/14B).

3. Is it desirable or necessary to issue prediction scales to suit each set of number strips provided?

413/6813/W

1st Ind.

War Department, O. C. C. A., April 10, 1926—To President, Coast Artillery Board, Ft. Monroe, Va. (Through Commandant, C. A. School).

1. For remark.

2. This subject should be considered in connection with the communication referred to in paragraph 1, basic letter, which was forwarded to you per 1st Indorsement, 413.6813/V, O. C. C. A., April 10, 1926.

2. In accordance with the foregoing instructions the Coast Artillery Board has endeavored to determine:

a. Whether or not it is desirable to continue to graduate the arms of Cloke Boards 30 graduations to the inch or to have some other number of graduations to the inch.

b. To what scales should the replaceable number strips for Cloke Boards be graduated?

c. Should the replaceable number strips issued with Cloke Boards be varied to suit the armament?

d. Should prediction scales be issued to suit each set of number strips provided?

## II—DISCUSSION.

3. In this discussion the board having a 38-inch effective radius is called "Short-Range Cloke Plotting Board," and that having a 55-inch effective radius, "Long-Range Cloke Plotting Board."

a. The Short-Range Cloke Board has an effective plotting radius of 38 inches, and the arms have 30 graduations per inch. The Coast Artillery Board considers number strips having scales of 300, 600, and 750 yards per inch as satisfactory. With these scales the least readings are respectively 10, 20, and 25 yards.

b. A scale of 900 yards per inch has a least reading of 30 yards and a scale of 1200 yards per inch has a least reading of 40 yards. These values are not believed to be satisfactory in that their use will tend to produce errors. It is the opinion of the Coast Artillery Board that the least reading in every case should be an integral divisor of 100.

c. It is not believed that a satisfactory degree of accuracy will be attained with a scale of 1500 yards per inch.

d. Consider the armament to be divided into two classes:

(1) The 14-inch railway and 16-inch guns which should be provided with Long-Range Cloke Boards (it is understood that the long-range board will have an effective plotting radius of approximately 55 inches).

(2) All other armament, with the possible exception of the 16-inch howitzer, which should be provided with the Short-Range Cloke Board. It will be seen that with arms graduated 30 divisions per inch it will be impossible to provide scales, the least readings of which will be integral divisors of 100, and obtain the

maximum ranges required for some of the armament of the second class, as the 12-inch railway and 12-inch B. C. Guns.

4. *a.* The following tables show for the Short-Range Cloke Board the scales, least readings, and maximum ranges obtainable with different graduations of the arms:

## 20 GRADUATIONS PER INCH

<i>Scales (per inch)</i>	<i>Least reading</i>	<i>Maximum range</i>
100 yards	5 yards	3,800 yards
200 yards	10 yards	7,600 yards
400 yards	20 yards	15,200 yards
500 yards	25 yards	19,000 yards
1000 yards	50 yards	38,000 yards

## 25 GRADUATIONS PER INCH

125 yards	5 yards	4,750 yards
250 yards	10 yards	9,500 yards
500 yards	20 yards	19,000 yards
625 yards	25 yards	23,750 yards
1250 yards	50 yards	47,500 yards

## 30 GRADUATIONS PER INCH

150 yards	5 yards	5,700 yards
300 yards	10 yards	11,400 yards
600 yards	20 yards	22,800 yards
750 yards	25 yards	28,500 yards
1500 yards	50 yards	57,000 yards

## 40 GRADUATIONS PER INCH

200 yards	5 yards	7,600 yards
400 yards	10 yards	11,400 yards
800 yards	20 yards	30,400 yards
1000 yards	25 yards	38,000 yards
2000 yards	50 yards	76,000 yards

*b.* A consideration of the foregoing indicates that the Short-Range Cloke Board, with effective plotting radius of 38 inches, with arms graduated 40 graduations per inch and provided with sets of number strips graduated 200, 400, 800, and 1000 yards per inch meets the requirements of all armament, except the 14-inch railway and 16-inch gun, and possibly 16-inch howitzers, better than any of the other combinations considered.

*c.* The Long-Range Cloke Board with effective plotting radius of approximately 55 inches, with arms graduated 40 graduations per inch and provided with sets of number strips graduated 200, 400, 800, and 1000 yards per inch, should meet all requirements of the 14-inch railway and 16-inch guns.

*d.* A scale of 200 yards per inch is believed to be necessary in each case for sub-caliber practice.

*e.* One-fortieth of an inch is not believed to be too small a division for accurate rapid work.

5. The Coast Artillery Board believes that but one prediction scale is necessary with each Cloke Board, regardless of the number of sets of replaceable number strips provided. On a prediction scale the graduations and their corresponding numbers are used rather as reference numbers in determining the relation of the travel during one predicting interval plus the time of flight to the

travel during one predicting interval than as units in measuring distances. Any convenient arbitrary scale may be used for this purpose. Except for the case when the scale of the prediction scale is the same as that of the set of number strips being used, the word "yards" printed on the prediction scale has no meaning. Hence, if a prediction scale is to be used with number strips other than those of the same scale as the prediction scale the word "yards" should not appear on it.

6. The adoption of a standard predicting device and the issue of one of these devices with each Cloke Board should obviate the necessity of issuing any prediction scales. It is the opinion of the Coast Artillery Board that such a device eventually will be adopted.

### III—CONCLUSIONS.

7. The Coast Artillery Board is of the opinion:

a. That Cloke Plotting and Relocating Boards in the future should have the arms graduated 40 graduations to the inch.

b. That there should be issued with each Cloke Plotting and Relocating Board, the arms of which have 40 graduations per inch, replaceable number strips graduated 200, 400, 800, and 1000 yards per inch.

c. That it is desirable to use no smaller scale than 1000 yards per inch.

d. That ultimately 14-inch railway and 16-inch gun batteries, and possibly 16-inch howitzer batteries, should be provided with Long-Range Cloke Plotting and Relocating Boards.

e. That only one prediction scale should be issued with each Cloke Plotting and Relocating Board.

### IV—RECOMMENDATIONS.

8. The Coast Artillery Board recommends:

a. That the arms of both types of Cloke Plotting and Relocating Boards be graduated 40 graduations per inch.

b. That there be issued with each Cloke Plotting and Relocating Board the arms of which are graduated 40 divisions per inch, sets of replaceable number strips graduated 200, 400, 800, and 1000 yards per inch.

c. That long range Cloke Plotting and Relocating Boards ultimately be provided each battery of 14-inch railway and 16-inch guns.

d. That but one prediction scale be issued with each Cloke Plotting and Relocating Board.

e. That, for purposes of uniformity, prediction scales be graduated 40 divisions per inch with zero at the center and graduations to be numbered at ten division intervals to the right and left of zero, fifties and hundreds to be emphasized as is customary, the length of the scale to be 12 inches.

### V—ACTION OF THE CHIEF OF COAST ARTILLERY.

413.6813/W-1

1st Ind.

War Department. O. C. C. A., May 6, 1926—To the Chief of Ordnance.

1. The proceedings of the Coast Artillery Board on Project No. 460 are inclosed herewith. The conclusions and recommendations contained therein are concurred in.

2. The data contained in these proceedings answer in full the questions raised in letters, Chief of Ordnance, April 6, 1926, file O. O. 413.481/140 and 413.683/328 respectively.

3. A copy of these proceedings may be retained for your files.

# BOOK REVIEWS

---

*The Study of War.* By Major General Sir Ernest Swinton, K. B. E., C. B., D. D. O., Chichele Professor of Military in the University of Oxford. Oxford University Press. 1926. 6"x 9". 26 pp. \$0.70.

This inaugural lecture (delivered before the University of Oxford on February 23, 1926) is unusual because it is not tiresome but entertaining. It is intended to demonstrate "that the general knowledge of military history is as important as that of social economic or political history." Considering the brevity of the paper, the proof is convincing in an astonishing degree.

The style and character of this lecture can perhaps best be indicated by the following extracts from the concluding paragraph:

If, on the other hand, we think, as I think, that we have not reached a state at which the prospect of the recurrence of war can be disregarded, then apart from any question of sentimental or academic interest, we cannot, as a matter of practical utility and as a vital precaution, afford to neglect the past history of this sphere of human activity. The greatest service which its study can render is to prevent our stumbling into hostilities because we do not recognize the signs nor appreciate the implications of their approach.

If they go forth [from Oxford] into the world after ordered reflection on the nature of war and with a true conception of how the State may best prepare for it, avoid it, or meet it if and when it comes, they will be equipped to help their country at a time when help is more required.—R. S. A.

*Mesopotamia Campaign, Vol. III.* (Official History of the Great War). Compiled by Brig. Gen. F. J. Moberly, C. B., C. S. I., D. S. O., p. s. c. His Majesty's Stationery Office, London. 1925. 5¼"x 8½". 460 pp. Ill. 15s.

This volume deals with the operations from the surrender of Kut-el-Amara in April, 1916, to the end of April, 1917. Like almost all British Official War History it is notably dispassionate and free of partisan bias, but, like the earlier volumes of this series, it seems too ready to condone or excuse the inactivity or tardiness of British commanders.

It is pointed out that the surrender of Kut left both sides exhausted and incapable of effective action, and that the inability of the Turks, who were numerically the weaker, to attack made British withdrawal unnecessary, as it was inadvisable in view of its moral effect on the Arabs and probably unfavorable reaction on the situation in Persia and Afghanistan and that of the Russian Caucasus Army.

The period of tactical inactivity which lasted until December 14, 1916, was employed by the British in reorganizing and reinforcing "Force D" (as the force in Mesopotamia was designated) and in making preparations for an offensive should that appear desirable during the winter season. General Lake was relieved on August 28 as G. O. C. by General Maude. It is to be noted that the end of November found the British ration strength on the different fronts and lines of communications at 221,150 and the combatant strength at more than 100,000.

The British offensive against Kut and the advance to Baghdad (about 140 miles distant) lasted from December 14, 1916, to March 11, 1917, the British striking force having a strength of 3500 sabers, 45,000 rifles, and 174 guns, and the Turks not more than 15,000 of all arms. It would appear that the British operations were conducted creditably to the ability of the leaders and the courage and endurance of the troops, but that the resistance of the Turks demonstrated the fighting ability of the race to an astonishing degree. The small Turkish force scattered over the long river line was never stampeded, rarely surprised, and not only held its positions stubbornly, but counterattacked fiercely, and often successfully. Halil, the Turkish commander, seems to have been guilty of numerous errors but was able to withdraw his force without disaster and to inflict losses always approximating and frequently exceeding his own.

The reader can hardly escape the conclusion that a great opportunity was lost through the inactivity of the Russian Caucasus Army and that its advance in cooperation with the British might have resulted in the capture or destruction of almost the entire XIII and XVIII Turkish Corps.

The account of the minor operations after the capture of Baghdad is very interesting and the present volume closes with the British firmly established in and around Baghdad and preparing to deal with the larger enemy force available as a result of the Russian collapse.

This volume is full of meat for the military student, and by aid of the accompanying maps permits a sufficiently detailed study of the entire operation. It is, for an official account, astonishingly readable.—R. S. A.

*Man and Weather.* By Alexander McAdie. Harvard University Press, Cambridge, Mass. 1926. 5"x 7½". 99 pp. Ill. \$2.00.

Professor McAdie has the happy faculty of writing in a fascinating manner about highly technical subjects. This treatise on certain features of meteorology can hardly be said to have been written in non-technical language entirely, but it is written with clarity and the reader need not be a scientist to understand. The fund of information contained combined with the literary style of the author make it a desirable addition to any library.

The first two chapters are devoted to "The Strategy of Weather in War" and "Weather in Peace." Therein the author points out the importance of knowing the atmosphere and develops an interest in the chapters to come. The last four chapters are given to a study of "The Structure of the Atmosphere," "Clouds, Fogs, and Water Vapor," "Lightning," and "Droughts, Floods, and Forecasts."

The book is well organized and ably presented. It has particular interest for the military man.—C. S. H.

*Fix Bayonets.* By Captain John W. Thomason, Jr., U. S. Marine Corps. Charles Scribner's Sons, New York and London. 1926. 7"x 9¼". 245 pp. Ill. \$3.50.

Captain Thomason's book is an account of the experiences in battle of the Marines who formed a part of the Second Division in France. The chapters are sketches of the events which occurred in the author's immediate vicinity on the battlefields and are filled with infinite detail of the men and their emotions in battle. The Marine, as depicted by Captain Thomason, is not unlike the professional soldier or the experienced National Guardsman in other organizations in France. The men who figure in these stories of action were entirely American in their impersonal and unemotional attitude toward the war. The two slogans which best indicate their characteristics were "Let's go" and "When do we eat?"

Captain Thomason, with the vision of an artist, has caught the spirit of the American soldier and has painted a vivid series of word pictures, which are, however, no more striking than the sketches with which he illustrates his book. Many of these were drawn on scraps of paper in the field and, are markedly expressive. The book is unusual and is sure to be of interest to every one who reads it.

*How to Live.* By Irving Fisher and Eugene Lyman Fisk, M. D. Funk and Wagnalls Company, New York. 1926. 5"x 7 $\frac{3}{4}$ ". 513 pp. Ill. \$2.00.

This volume furnishes rules for healthful living based on modern science. It is authorized by and prepared in collaboration with the Hygiene Reference Board of the Life Extension Institute. This edition—the eighteenth—is completely revised and new matter has been added embodying information gathered during the World War and since. "How to Live" is now approaching its tenth anniversary.

From its title it can be seen that a broad field is covered. The first chapter is devoted to Air and it includes a discussion of housing, clothing, ventilation, and outdoor living. Chapters are devoted to foods and poisons. The fourth chapter covers work, exercise, rest, and sleep. The remainder of the book makes a study of individual and public hygiene. Supplements are added covering such special subjects as weight regulation, tobacco, alcohol, and eugenics.

The authors treat their subjects with a broad viewpoint. Their teachings are sound and helpful. There are no radical views to detract from the value of the work. The book is well worth study and it could very profitably be added to every company library.—C. S. H.

*Whitehead's Complete Auction Bridge.* By Wilbur C Whitehead. Frederick A. Stokes Company, New York. 1926. 5"x 7 $\frac{1}{2}$ ". 308 pp. \$2.50.

In these days, when bridge has practically displaced all other card games in the Army, it is almost necessary for an officer to have in his library an authoritative work on the game. Mr. Whitehead's book is one of the most recent and most authoritative. The author is co-editor of the *Work-Whitehead Bridge Bulletin*, and his writings on bridge are known to bridge players throughout the country. The present work contains a discussion of all the new laws; of four-card suit bids, which are gaining in popular favor; and of defensive bidding and play, in addition to the usual chapters on the various principles of bidding and play. Mr. Ralph J. Leibenderfer has contributed a remarkable chapter on justifiable overbidding. The book contains the laws of Auction Bridge as revised in the spring of 1926 by the Whist Club of New York. The volume is of a convenient size, and the type is clear and pleasing. Few typographical errors are noted. The lack of an index, common to most books on bridge, is a handicap.

*Digging for Lost African Gods.* By Count Byron Khun de Prorok. G. P. Putnam's Son, New York and London. 1926. 6"x 9 $\frac{1}{4}$ ". 369 pp. Ill. \$6.00.

During the past five years the Count de Prorok has been engaged in archeological excavations at Carthage and through Tunisia and in the Sahara. He started with limited facilities and inadequate funds, carrying on the work begun by Jules Renault. His enthusiasm and his discoveries have resulted in the organization of a large and efficient expedition, numbering in its personnel experts in many fields, such as geology, petrography, paleontology, engineering, photography and motion pictures, motor transport, cataloguing, aeronautics, surveying, archi-

ture, the several departments of archeology, and so on. Within the past year and a half this expedition has made many remarkable discoveries at Carthage and Utica, along the Mediterranean coast, and in the Sahara. In this book the author tells in an entertaining fashion somewhat of the history and the results of the excavations made at these several points in Northern Africa. The language is not technical. The discoveries which he describes range all the way from the remains of primitive man through Phœnician, Egyptian and Carthaginian remains to those of Roman times, and include the location of Homer's "City of the Lotus Eaters," long lost beneath the sea. Personal experiences, twentieth-century tourists, up-to-date realty dealers, difficulties of motor transportation in the desert, descriptions of the Arab laborer and his tendency to strike, explorations underneath the sea, and many delightful illustrations make the book more than usually readable.

*Whys of Auction Bridge.* By Henry L. Raymond. Bobbs-Merrill Co., Indianapolis. 1926. 4¾" x 7½". 203 pp. \$2.00.

The author is a highly successful and popular teacher of Bridge and, in the present book, has presented in simple and carefully arranged manner the principles of the game. The book is notable particularly for its simplicity of arrangement, whereby it is made much easier to read than most of the books which are now on the market. Colonel Raymond does not differ in his advice on general principles or on major details from the other well-known authorities. The book was published just before the adoption of the cast of rules for 1926, and the laws of Auction Bridge as given in his volume are not those being used at present. Except in minor detail, however, this does not affect the value of the work. The book is recommended to anyone who may find Work or Whitehead hard to read.

*How to Write a Short Story.* By Michael Joseph. Henry Holt and Company, New York. 1926. 4¾" x 7½". 116 pp. \$1.75.

The author is manager of one of the largest literary agencies in the world and has had a long and extensive experience with short stories. He knows how short stories should be written, and in this book he shows others how to write successfully. The volume contains much that will be of assistance to the new writer. It shows the difference between the short story and the story of book length. For purposes of discussion the short story is split up into three main divisions and each is discussed with a view to obtaining a complete story. The author advises writing with a definite market in mind rather than in finding the market after the story has been written. The latter part of the book is devoted to advice on preparation of the manuscript and in details concerning its sale.

*The Law of Destiny.* By Ralph W. Wiles. Dorrance and Company, Philadelphia. 1926. 5" x 7½". 277 pp. \$2.00.

The experiences of twin brothers, very similar in appearance and equally dissimilar in character.

**HOTEL ASTOR—NEW YORK**  
FRED'K A. MUSCHENHEIM  
**ARMY AND NAVY HEADQUARTERS**

*A Perfect Permanent Wave—Nestlé's Circuline Process*

*Hair Dressing, Shampooing, Facial and Scalp Massaging, Manicuring, Permanent Wave, Marcel Chiropody, and all Beauty Work. First Class Line of Hair Goods Carried in Stock. Phone 224.*

**NICHOLAS' BEAUTY SHOP**

3313 Washington Avenue

NEWPORT NEWS, VIRGINIA

(Patent Pending)

Application blanks  
at Journal Office

Cable Address  
USAUTO



**WRITE FOR  
PARTICULARS**

**INSURANCE  
AT COST**

For Officers, Warrant Officers, ACTIVE and RETIRED, and Field Clerks, of the United States Services  
**UNITED SERVICES AUTOMOBILE ASSN.** (Formerly U. S. A. A. I. A.)  
FOR SAM HOUSTON, TEXAS

**STUDEBAKER**

**SALES :: SERVICE :: PARTS**

**Newport News Motor Car Company**  
INCORPORATED

**B. J. STEPHENSON, Secretary and Treasurer**

232-238 27TH ST., NEWPORT NEWS



101 E. QUEEN ST., HAMPTON



**The MAGNOLIA TREE INN**

LUNCHEON · DINNER  
AFTERNOON TEA

TEA ROOM AND GIFT SHOP

ROOMS AND BOARD BY DAY OR WEEK

*Special arrangements for card parties, etc.*

TELEPHONE: Hampton 951

26 S. KING STREET

HAMPTON, VIRGINIA

**EISEMANN'S**

**SHOES and HOSIERY**  
*That Satisfy*

2600 WASHINGTON AVENUE

NEWPORT NEWS, VIRGINIA

# McEnany & Scott

ARMY AND NAVY UNIFORMS AND EQUIPMENT

*High Grade Civilian Clothes*

E. T. McENANY

For 43 years manager  
Cadet Store, West Point

11 WEST 56TH STREET

*Telephone*  
CIRCLE 2811

ROBERT SCOTT

For 35 years cutter  
Cadet Store, West Point

NEW YORK

---

---

L. M. NEWCOMB  
*President*

G. K. VANDERSLICE  
*Vice-President*

## THE OLD POINT NATIONAL BANK

PHOEBUS, VIRGINIA

*Foreign  
Exchange*

*Travelers  
Checks*

YOUR NEAREST NATIONAL BANK  
*and*  
U.S. GOVERNMENT DEPOSITARY

---

WE CAN HANDLE YOUR ACCOUNT  
SATISFACTORILY TO YOU

*Safe Deposit  
Boxes*

*Four Per Cent Paid  
on Savings*

*Call on us for anything in regard to Banking*

P. McK. JOHNSON, *Cashier*

---

---

## B. W. WILSON PAPER COMPANY

RICHMOND, VIRGINIA

*Distributors of WARREN'S STANDARD PRINTING PAPERS and  
STRATHMORE QUALITY PAPERS*

*also all kinds of PRINTING PAPERS, CARDBOARDS and ENVELOPES  
for the Printer*

---

---

WHEN WRITING ADVERTISERS PLEASE MENTION THE COAST ARTILLERY JOURNAL



*Used by Uncle Sam's Expert Riflemen*

**HOPPE'S**

**NITRO SOLVENT POWDER No. 9**

(Trade Mark Registered)

FOR CLEANING HIGH POWER (*Springfield*) RIFLES, REVOLVERS, MACHINE GUNS AND FIREARMS OF ALL KINDS

Necessary to the success of all contestants for honors  
at every Rifle Match

*For sale at Hardware and Sporting Goods Stores and at Post Exchanges*

**FRANK A. HOPPE, INCORPORATED** 2314 N. EIGHTH ST.  
PHILADELPHIA, PA.

**The Philippine Trust Company**

Manila, P. I.

*Commercial and Savings Bank*

*Trust Department*

Special Attention Given to Army Accounts

M. H. O'MALLEY, *President*

*Ford*

WE SELL ANYWHERE

*Ford*

**SHACKELFORD AUTO COMPANY**

HAMPTON, VIRGINIA

*Ford*

*Lincoln-Ford-Fordson*

*Ford*



**FERGUSSON MUSIC COMPANY**

ESTABLISHED 1893

**EVERYTHING MUSICAL**

PHONE 566

2909-11 Washington Ave. NEWPORT NEWS, VA.



**COMPLETE LINE OF MILLINERY and  
LADIES' READY-TO-WEAR APPAREL**

MRS. M. B. GAMMON

13 Mellen Street

PHOEBUS, VIRGINIA



REGISTFRED

**N. S. MEYER, INC.,**

announce for the new lapel collar officer's blouse the finest insignia designs ever presented to the Military Trade. The designs are in keeping with the superior quality of N. S. MEYER, Inc., products.

On sale at all leading dealers and Exchanges.

**N. S. MEYER, INC.**

*Insignia Specialists*  
43 E. 19TH STREET  
NEW YORK

**BOOKS**

THE BOOKSHOP can secure for you any book on any subject, no matter where it is published. The price will never be more, and usually will be less than list price



**THE BOOKSHOP**

COAST ARTILLERY JOURNAL  
FORT MONROE, VA.

**NACHMAN'S DEPARTMENT STORE**

*We extend to the members of the Association of Army and Navy Stores the convenience of a charge account*

Washington Ave. at 30th St.

NEWPORT NEWS, VA.

**BRITTON - ROWELL HARDWARE COMPANY**

HARDWARE, PAINTS, OILS, PUTTY AND CROCKERY

*Window Glass and House Furnishings*

GOODYEAR TIRES AND TUBES

19-21 Mellen St., PHOEBUS, VA.

PHONE 559

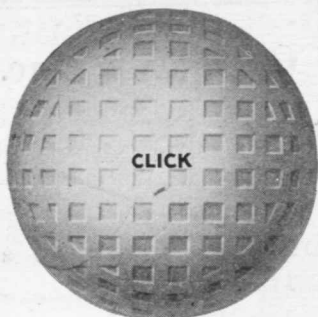

A  
COLONEL  
IS THE LONGEST  
DRIVING GOLF BALL  
MADE

The accuracy and balance, the enduring sturdiness—the extra long true flight of Colonel Golf Balls has been achieved thru constantly increasing the quality—and in spite of parallel increases in the cost of raw materials, they remain the same in price.

ASK FOR  
COLONEL  
GOLF BALLS

Click Colonel \$1 each, \$12 dozen. St. Mungo Colonel 75c each, \$9 dozen.  
Each one in dimpled and meshed markings.

ST. MUNGO MFG. CO. OF AMERICA  
121-123 SYLVAN AVE. NEWARK, N. J.

CUT BALLS REPLACED

---

---

The HEFFELFINGER COMPANY, Inc.

COAL, WOOD, LUMBER, and  
BUILDING MATERIAL

FOOT OF  
KING STREET

PHONES  
23 and 58

HAMPTON, VIRGINIA

---

---



RADIOLAS—  
RCA LOUDSPEAKERS  
and RCA ACCESSORIES

WE are glad to announce that we have been selected by the Radio Corporation of America to sell and service RADIOLAS, RCA LOUDSPEAKERS, and RCA ACCESSORIES

Radiolas . . . . . \$15 to \$575  
RCA Loudspeakers . . . . . \$18 to \$245

*Convenient Time payment may  
be arranged*

EVERYTHING IN RADIO

THE BOOKSHOP :: *Fort Monroe, Virginia*

---

---

*The Journal of the Royal Artillery*

PUBLISHED QUARTERLY

*By the Committee of the Royal Artillery Institution,  
Woolwich, London, S. E. 18*

SUBSCRIPTION, £1-0-0 PER ANNUM

---

---

WHEN WRITING ADVERTISERS PLEASE MENTION THE COAST ARTILLERY JOURNAL

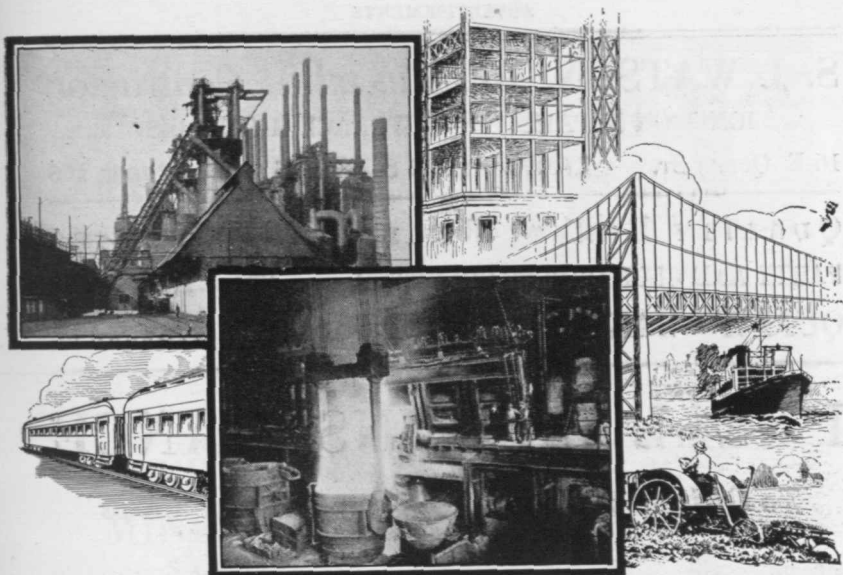

## STEEL — FOR EVERY PURPOSE — IN ANY QUANTITY

**STEEL** is used in some form in practically every industry.

In the railroad industry, in the automotive industry, in the shipbuilding industry—steel is essential.

In the manufacture of machinery, in the erection of bridges and buildings, in the manufacture of agricultural implements—steel is a first requirement.

In the manufacture of ordnance material, in the equipment for practically every military and naval purpose—steel is indispensable.

The raw materials that go into the making of Bethlehem steel are extracted from Bethlehem-owned and -operated mines and quarries. Bethlehem-owned vessels and cars transport these raw materials to Bethlehem Plants, and complete control of every process in the manufacture—from ore to finished product—insures consistent quality. Extensive manufacturing facilities enable Bethlehem to supply steel for every purpose in any quantity.

For many years Bethlehem has shared in supplying the nation's demand for commercial steel, manufactured steel products and ordnance material.

### BETHLEHEM STEEL COMPANY

— GENERAL OFFICES: BETHLEHEM, PA.

#### PLANTS AT

Bethlehem, Pa. Steelton, Pa. Johnstown, Pa. Lebanon, Pa. Reading, Pa.  
Coatesville, Pa. Lackawanna, N. Y. Sparrow's Point, Md.

# BETHLEHEM

WHEN WRITING ADVERTISERS PLEASE MENTION THE COAST ARTILLERY JOURNAL

---

---

**S. J. WATSON, JR., *Electrical Contractor***

IGNITION REPAIR

STORAGE BATTERIES

16 E. QUEEN ST.

RADIO—AUTO SUPPLIES

PHONE 166

---

**QUALITY BREAD, ROLLS *and* PASTRIES**

PARTY AND CLUB ORDERS SOLICITED

PHONE HAMPTON 75

**QUALITY BAKE SHOP, INCORPORATED** 56 W. QUEEN STREET  
HAMPTON, VA.

---

**I SELL LIFE INSURANCE**

*To Officers of the Army—Navy—Marine Corps*

MY SELLING POINTS ARE:

Low Rates.

Suitable Policy Forms—Life, Income, Educational.

Most Liberal Disability Provision.

Monthly Premium Payment by Allotment.

Double Benefit in Case of Accident.

**LAWRENCE C. CRAWFORD**

MAJOR, U. S. A., *Retired*

601 Woodward Building

WASHINGTON, D. C.

---

**JOE FRANK & SON**

210 THIRTY-FIRST STREET  
NEWPORT NEWS, VA.

*Expert Dyers and Cleaners*

*Daily Deliveries to Fort Monroe*

PHONE 2030

---

25 YEARS SERVICE TO OFFICERS OF THE CORPS

**SHERWOOD INN BARBER SHOP**

ANTONIO SARURRO, *Proprietor*

LADIES' WORK SOLICITED

SHERWOOD INN

FORT MONROE, VA.

---

*The  
Army  
Souvenir*

A  
PERFECT  
MINIATURE  
SABRE

---

CAN BE ENGRAVED WITH  
NAME OF POST, OF DONOR  
OR OF RECIPIENT

---

**\$1.50**  
Carriage Prepaid

---

Engraving 25 cents per line of  
16 letters

---

**THE BOOKSHOP**  
FORT MONROE, VA.

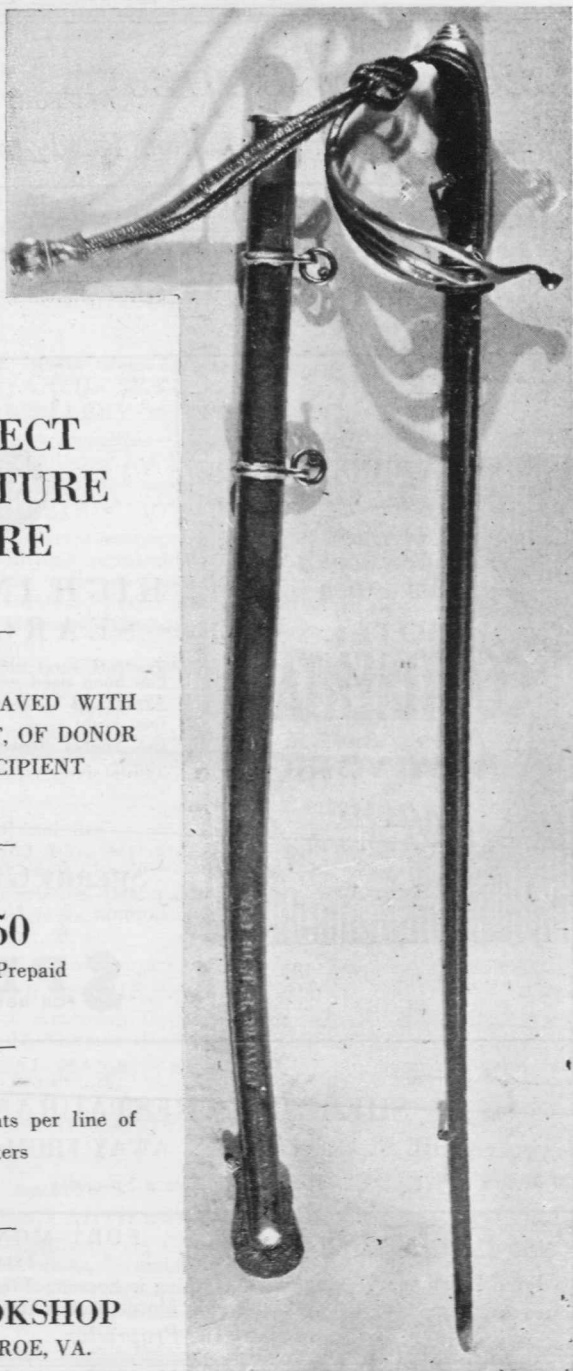

**Leon's Shoppe** 3021 Washington Ave.  
NEWPORT NEWS . VIRGINIA  
*Complete New Line of Ladies' Ready-to-Wear Apparel*

**THE PURITAN CONFECTIONERY** 31 EAST QUEEN STREET  
HAMPTON, VIRGINIA  
PURE HOME MADE CANDIES AND ICE CREAM  
*Home Made After-Dinner Mints, Salted Almonds, and Whipping  
Cream a Specialty* PHONE 856



**HIGH INTENSITY  
SEARCHLIGHT**

has been used exclusively by the U. S. Army and U. S. Coast Artillery for the past eight years. This fact alone proves the Sperry Searchlight as Supreme in quality and efficiency.

THE  
**SPERRY GYROSCOPE CO.**  
LONDON NEW YORK TOKYO

**SPERRY**  
FOR BETTER NAVIGATION

*Everything in Season*

*Tables for Ladies*

**SHERRILL'S RESTAURANT**

THE PLACE FOR MEN AWAY FROM HOME

120 Mellen Street

*Home-made Pies a Specialty*

PHOEBUS, VA.

**Post Exchange Market** FORT MONROE, VIRGINIA  
TELEPHONE 315

Fresh Fruits and Vegetables. Everything in Season. Fresh Killed Chicken  
a Specialty. Deliveries: Morning and Afternoon

M. CARLI, Proprietor

PUBLICATIONS OF THE  
**BOOKSHOP**  
 Coast Artillery Journal  
 Fort Monroe, Virginia

GUNNERY AND POSITION FINDING FOR ANTI-AIR-  
 CRAFT ARTILLERY ..... .75

HEAVY ARTILLERY MATERIEL:

Part III: Ammunition ..... \$ .25  
 Part IV: Pointing and Fire Control Instruments and Devices ..... .50  
 Part V: Signal Communications ..... .25

GUNNERS INSTRUCTION:

Fixed Mortars (complete without supplement)..... .50  
 Mine, with one supplement ..... .50  
 Fixed Gun, with one supplement ..... .50  
 Expert Gunners, Fixed Guns and Mortars..... .50  
 Expert Gunners, Tractor Artillery ..... .50

*Antiaircraft:*

Machine Gun Battery ..... .50  
 Gun Battery ..... .50  
 Searchlight Battery ..... .50  
 Expert Gunners ..... .50  
 Railway, complete without supplement ..... .50  
 Tractor Artillery, with one supplement ..... .50

SUPPLEMENTS

3-in. Rapid fire	6-in. Disappearing.
5-in. and 6-in. Barbette.	8-in. Disappearing.
10-in. Barbette.	10-in. Disappearing.
12-in. Barbette, 1892 model.	12-in. Disappearing.
12-in. Barbette, 1917 model.	14-in. Disappearing.
155-mm. G. P. F.	8-in. Howitzer.

Additional extra supplements for any Gunners' Instructions ..... .10

OPERATIONS OF THE 29TH DIVISION:

Volume I, American Documents ..... 1.25  
 Volume II, German Documents ..... 1.00

MECHANICAL MANEUVERS:

Paper covers ..... .20

MILITARY MOTOR TRANSPORTATION, 414 pages:

Board covers ..... 1.25  
 Cloth covers ..... 2.25  
 Flexible leather ..... 3.50

HEAVY (Coast) ARTILLERYMAN'S FIELD POCKETBOOK:

(The information every Coast Artillery Officer needs, in loose-  
 leaf form, tables, formulæ, forms, and data sheets, 206 p.)

Sheets without cover ..... \$1.50  
 Sheets with covers ..... from \$2.85 to \$6.50

ADVERTISEMENTS

# HOUSTON

PRINTERS  
PUBLISHERS  
ENGRAVERS

*De Luxe Printing at a Fair Price*



HOUSTON BUILDING

HAMPTON. VIRGINIA

WHEN WRITING ADVERTISERS PLEASE MENTION THE COAST ARTILLERY JOURNAL

# Target Practice Essay Competition

## PRIZES

First Prize .....	\$60.00
Second Prize .....	\$40.00
Third Prize .....	\$20.00

**SUBJECT:** A description of a preparation for and conduct of a target practice, or any phase or feature thereof.

**PURPOSE:** To secure for publication in the JOURNAL, the experiences and viewpoints of officers who recently have trained for, engaged in, or reported upon the results of target practices.

**NOTE:** This Competition is additional to and not in place of the JOURNAL'S Annual Prize Essay Competition.

## CONDITIONS

(a) The competition is open to any officer of the Coast Artillery branch of the Regular Service, National Guard or Organized Reserves.

(b) The articles must be descriptive of practices held between November 1, 1925, and September 15, 1926, at batteries of 3-inch guns or larger caliber.

(c) Articles may relate to Fixed Artillery, Tractor Drawn Artillery, Anti-aircraft Artillery or Railway Artillery.

(d) Articles must not exceed 3000 words in length (approximately eight typewritten, double spaced pages of legal cap paper). Photographs, drawings, etc., may however, be submitted in addition if desired.

(e) All articles entered in the competition become the property of the JOURNAL.

(f) No competitor may submit more than one article.

(g) Articles must be received on or before October 1, 1926, and be addressed to the COAST ARTILLERY JOURNAL.

(h) Award will be made by a Committee of Award consisting of three officers to be nominated by the Editor.

(i) Articles must contain nothing to indicate authorship. They must be signed with a *nom de plume* and must be accompanied by a sealed envelope containing the *nom de plume* and the name of the person submitting same. These envelopes will remain in the hands of the Editor of the JOURNAL until after the award has been made by the Committee. They will then be opened by the Executive Officer of the Third Coast Artillery District.

F. W. DARLING, *President*

H. H. HOLT, *Vice-President*

W. H. FACE, *Cashier*

G. B. BRADFORD, *Asst. Cashier*

# The Bank of Hampton, Virginia

HAMPTON, VIRGINIA

*Located Near Fort Monroe, Virginia*

“A FRIEND TO THE ARMY”

---

**Capital, Surplus and Profits - over \$550,000.00**

**Resources - - - - over 3,000,000.00**

---

**The OLDEST BANK on the PENINSULA**

You can, and a great many officers do, bank with us as easily by mail as in person. Write to us about it. Special attention given to all Army Accounts and we will be pleased to serve or advise in all financial or business matters.

**4% Interest Paid on Savings Deposits**