

**A PENDING MAJOR CRISIS:  
An Analysis of the Critical Shortage  
of US Army Officers in Year Groups 1991-1997**

A thesis presented to the Faculty of the U.S. Army Command  
and General Staff College in partial fulfillment  
of the requirements for the degree:

**MASTER OF MILITARY ART AND SCIENCE  
Transformation**

by

**GEORGE B. BROWN III, MAJOR, US ARMY  
MA 2002 Webster University, St Louis, MO;  
BS 1995 Appalachian State University, Boone, NC**

**United States Army Command and General Staff College  
Fort Leavenworth, Kansas**

2008-02

Approved for public release; distribution is unlimited.

<b>REPORT DOCUMENTATION PAGE</b>			<i>Form Approved</i> OMB No. 0704-0188		
Public reporting burden for this collection of information is estimated to average 1 hour per response, including the time for reviewing instructions, searching existing data sources, gathering and maintaining the data needed, and completing and reviewing this collection of information. Send comments regarding this burden estimate or any other aspect of this collection of information, including suggestions for reducing this burden to Department of Defense, Washington Headquarters Services, Directorate for Information Operations and Reports (0704-0188), 1215 Jefferson Davis Highway, Suite 1204, Arlington, VA 22202-4302. Respondents should be aware that notwithstanding any other provision of law, no person shall be subject to any penalty for failing to comply with a collection of information if it does not display a currently valid OMB control number. <b>PLEASE DO NOT RETURN YOUR FORM TO THE ABOVE ADDRESS.</b>					
<b>1. REPORT DATE (DD-MM-YYYY)</b> 12-12-2008		<b>2. REPORT TYPE</b> Master's Thesis		<b>3. DATES COVERED (From - To)</b> FEB 2008 – DEC 2008	
<b>4. TITLE AND SUBTITLE</b>  A PENDING MAJOR CRISIS: An Analysis of the Critical Shortage of US Army Officers in Year Groups 1991-1997			<b>5a. CONTRACT NUMBER</b>		
			<b>5b. GRANT NUMBER</b>		
			<b>5c. PROGRAM ELEMENT NUMBER</b>		
<b>6. AUTHOR</b>  George B. Brown III, Major, US Army			<b>5d. PROJECT NUMBER</b>		
			<b>5e. TASK NUMBER</b>		
			<b>5f. WORK UNIT NUMBER</b>		
<b>7. PERFORMING ORGANIZATION NAME(S) AND ADDRESS(ES)</b> U.S. Army Command and General Staff College ATTN: ATZL-SWD-GD Fort Leavenworth, KS 66027-2301			<b>8. PERFORMING ORG REPORT NUMBER</b>		
<b>9. SPONSORING / MONITORING AGENCY NAME(S) AND ADDRESS(ES)</b>			<b>10. SPONSOR/MONITOR'S ACRONYM(S)</b>		
			<b>11. SPONSOR/MONITOR'S REPORT NUMBER(S)</b>		
<b>12. DISTRIBUTION / AVAILABILITY STATEMENT</b> Approved for Public Release; Distribution is Unlimited					
<b>13. SUPPLEMENTARY NOTES</b>					
<b>14. ABSTRACT</b> <p>There is a pending crisis in the US Army that has received little attention, but that is having a critical effect on the military and its ability to continue its high current operational tempo. The pending crisis is a shortage of US Army field grade officers.</p> <p>The retirement rate of officers reaching 20-years of service last year was 20%; a survey conducted for this thesis indicates the rate could grow to 60%. This loss rate suggests that by 2014, the US Army may be short 30% lieutenant colonels and 20% majors. The most critical aspect of this potential 30% shortage of lieutenant colonels and 20% shortage of majors will be that it is not equally distributed across all the branches. By 2014, indications suggest that most of the US Army officer branches will face shortages greater than 50% of their requirement for lieutenant colonels and majors.</p> <p>The security of the United States depends on senior military and civilian leadership recognizing these issues before they become critical and reach a tipping point beyond what can be quickly resolved. Potential initiatives to correct the current problems include (1) conducting an information campaign (short term); (2) formalizing incentive programs already in use (near term); and (3) creating a monetary bonus program similar to those used for enlisted Soldiers (long term). Other more drastic options are available to address the shortages, but the second order effects may do more damage than good to the US Army.</p>					
<b>15. SUBJECT TERMS</b> Shortage of Officers; Pending Crisis; US Army Officers; Major Crisis; Army Survey; Military; US Army, Transformation					
<b>16. SECURITY CLASSIFICATION OF:</b>			<b>17. LIMITATION OF ABSTRACT</b>	<b>18. NUMBER OF PAGES</b>	<b>19a. NAME OF RESPONSIBLE PERSON</b> George B. Brown III
<b>a. REPORT</b> (U)	<b>b. ABSTRACT</b> (U)	<b>c. THIS PAGE</b> (U)			(U)

Standard Form 298 (Rev. 8-98)  
Prescribed by ANSI Std. Z39.18

MASTER OF MILITARY ART AND SCIENCE  
THESIS APPROVAL PAGE

Name of Candidate: Major George B. Brown III

Thesis Title: A PENDING MAJOR CRISIS: An Analysis of the Critical Shortage of  
US Army Officers in Year Groups 1991-1997

Approved by:

  
\_\_\_\_\_, Thesis Committee Chair  
MG(R) Ralph O. Doughty, PhD

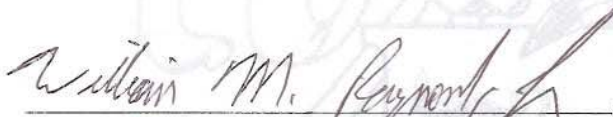
  
\_\_\_\_\_, Member  
COL William M. Raymond, Jr., PhD

  
\_\_\_\_\_, Member  
COL(R) David Hunter-Chester

Accepted this 12th day of December 2008 by:

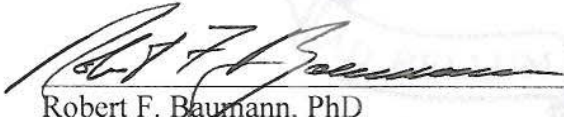
  
\_\_\_\_\_, Director, Graduate Degree Programs  
Robert F. Baumann, PhD

The opinions and conclusions expressed herein are those of the student author and do not necessarily represent the views of the U.S. Army Command and General Staff College or any other governmental agency. (References to this study should include the foregoing statement.)

## ABSTRACT

### A PENDING MAJOR CRISIS: An Analysis of the Critical Shortage of US Army Officers in Year Groups 1991-1997

By Major George B. Brown III, 153 pages

There is a pending crisis in the US Army that has received little attention, but that is having a critical effect on the military and its ability to continue its high current operational tempo. The pending crisis is a shortage of US Army field grade officers.

The retirement rate of officers reaching 20-years of service last year was 20%; a survey conducted for this thesis indicates the rate could grow to 60%. This loss rate suggests that by 2014, the US Army may be short 30% lieutenant colonels and 20% majors. The most critical aspect of this potential 30% shortage of lieutenant colonels and 20% shortage of majors will be that it is not equally distributed across all the branches. By 2014, indications suggest that most of the US Army officer branches will face shortages greater than 50% of their requirement for lieutenant colonels and majors.

The security of the United States depends on senior military and civilian leadership recognizing these issues before they become critical and reach a tipping point beyond what can be quickly resolved. Potential initiatives to correct the current problems include (1) conducting an information campaign (short term); (2) formalizing incentive programs already in use (near term); and (3) creating a monetary bonus program similar to those used for enlisted Soldiers (long term). Other more drastic options are available to address the shortages, but the second order effects may do more damage than good to the US Army.

## ACKNOWLEDGMENTS

No one completes a thesis like this by himself. I would like to offer the utmost gratitude to my thesis committee chairman: Dr. Ralph O. Doughty, Ph.D for his patience, persistence, and overwhelming amount of time dedicated to the proper completion of this project; my thesis committee: COL William M. Raymond, Jr., Ph.D., and COL(R) David Hunter-Chester for their insightful and instructive direction; LTG William B. Caldwell IV, Commanding General of the US. Army Combined Arms Center, for his support of the MMAS program and the latitude for critical thinking and strategic communication among the officers in the Command and General Staff College; the Fort Leavenworth Combined Arms Research Library staff and MAJ Derek Burt from Human Resources Command for giving me almost too much information to handle; COL Paul L. Aswell and COL Chris Robertson of the US Army Human Resources Command for their abundance of cooperation and educated insight; Mr. Rick Steele for making the process to properly initiate a survey virtually trouble-free; Ms. Maria Clark for the patience in assisting me in the design of the survey; Dr. David Bitters for facilitating the analysis of the statistical data; Dr. Bill J. McCollum and Dr. Constance A. Lowe, CGSC MMAS seminar instructors, LTC Scott Nester PhD Director, Center for Data Analysis & Statistics, West Point and Dr Fred Milano, professor emeritus of sociology, Appalachian State University, for the high-quality feedback after proofing my draft thesis several times; my neighbor, Major Mike Wise and his wife Becky, for the scores of hours of dialogue on this topic while relaxing in the front yard over some homebrew; fellow 2008 Command and General Staff College students (in particular, Staff Group 5/B (“Five Banzai”)); MAJ Mike Halley; MAJ Sam Escalante; MAJ Kim Nash; and MAJ Joe

Jackson) for encouragement, support, and a plethora of editorial comments; my dogs, Liberty and Justice, for allowing me a couple of hours of tranquility each day; and to my wife and best friend, Sandra, for everything else.

Without the support and effort of those listed above, as well as others, I could not have completed this thesis. However, responsibility for errors in fact or judgment rests with me alone.

# TABLE OF CONTENTS

	Page
ABSTRACT.....	iv
ACKNOWLEDGMENTS .....	v
TABLE OF CONTENTS.....	vii
ILLUSTRATIONS .....	ix
TABLES .....	x
ACRONYMS.....	xi
CHAPTER 1 INTRODUCTION AND OVERVIEW .....	1
The Pending Crisis.....	1
How did the US Army Arrive at this Crisis? .....	5
CHAPTER 2 HISTORICAL REVIEW .....	15
Background.....	15
Military Retirement Program.....	26
CHAPTER 3 RESEARCH DESIGN.....	28
CHAPTER 4 ANALYSIS.....	32
Analysis .....	32
Statistical Information from Specific Branches of Note.....	40
The Future.....	42
Thesis Limitations.....	48
CHAPTER 5 CONCLUSIONS AND RECOMMENDATIONS .....	51
Conclusions.....	51
Recommendations.....	54
Information Campaigns .....	55
Formalize Incentive Programs .....	56
Monetary Bonus Programs .....	57
Less Desirable Options .....	59
Summary .....	63
APPENDIX A SURVEY .....	64

Approval Letter.....	64
Survey .....	66
Survey Results .....	70
APPENDIX B SURVEY COMMENTS .....	84
APPENDIX C EMAIL FROM THE ARMY CAREER AND ALUMNI PROGRAM (ACAP) .....	94
APPENDIX D MAJOR CRISIS ARTICLE IN THE <i>WASHINGTON POST</i> .....	96
APPENDIX E BATTLE COMMAND KNOWLEDGE CENTER (XO/S3 NET) COMMENTS .....	116
REFERENCE LIST .....	133
INITIAL DISTRIBUTION LIST .....	139

ILLUSTRATIONS

	Page
Figure 1. Shortage of US Army Officers as a Percent of the Total of Officer Shortages (US Army G-1 2008).....	3
Figure 2. Shortage of Required US Army Officers, by Rank (US Army G-1 2008).....	7
Figure 3. Percent of Majors that Leave the US Army Each Year (US Army G-1 2008)..	8
Figure 4. Officer Promotion Timeline (Army Regulation 600-8-29 2005) .....	9
Figure 5. Number of US Army Officers by Year Group (US Army G-1 2008) .....	13
Figure 6. Cash vs. Non-Cash Benefits (Heritage 2004).....	18
Figure 7. Example of the Cost to Hire One Security Guard From Blackwater (Neff 2008) .....	19
Figure 8. Trend of the Percent of Majors and Lieutenant Colonels Leaving the US Army Each Year (US Army G-1 2008) .....	29
Figure 9. Required vs. Predicted Number of Officers in 2010 (Source: Author) .....	33
Figure 10. Required vs. Predicted Number of Officers in 2011 (Source: Author) .....	34
Figure 11. Required vs. Predicted Number of Officers in 2012 (Source: Author) .....	34
Figure 12. Required vs. Predicted Number of Officers in 2013 (Source: Author) .....	35
Figure 13. Required vs. Predicted Number of Officers in 2014 (Source: Author) .....	35
Figure 14. Percent of Active Duty Majors and Lieutenant Colonels Separating from the US Army (US Army G-1 2008).....	45

## TABLES

	Page
Table 1. Army's Percentages of Overfilled and Under-filled Required Positions for Majors in Specified Branches for FY 2007 .....	13
Table 2. Retention-related pays and incentives for officers in 2006 .....	16
Table 3. Trend of Comments from the Survey .....	37
Table 4. Raw Survey Data .....	70
Table 5. Majors that Plan to Get Out of the Service at 20 Years or Less .....	73
Table 6. Extracted Survey Results .....	76
Table 7. Comparison of Survey Answers .....	80

## ACRONYMS

1LT	First Lieutenant
2LT	Second Lieutenant
ACAP	US Army Career and Alumni Program
AGR	Active Guard Reserve
CG	Company Grade Officer (2LT/1LT/CPT)
CGSC	Command and General Staff College (Ft Leavenworth, KS)
CGSS	Command and General Staff School (part of CGSC)
COL	Colonel
BA	Bachelor of Arts
BS	Bachelor of Science
DA	Department of the US Army
DoD	Department of Defense (US)
FG	Field Grade Officer (MAJ/LTC/COL)
FT	Fort
FY	Fiscal Year
G-1	US Army Human Resource Section
GAO	Government Accounting Officer
HRC	Human Resources Command
ILE	Intermediate Level Education
KD	Key Developmental Job/Branch Qualifying Job (ie Battalion S3 or XO)
KS	Kansas
LT	Lieutenant
LTC	Lieutenant Colonel
MA	Master of Arts
MACOM	Major Command
MAJ	Major
MBA	Master of Business Administration
MS	Master of Science
MMAS	Master of Military Arts and Science
PAM	Pamphlet
PhD	Philosophiæ Doctor (Doctor of Philosophy)
ROTC	Reserve Officer Training Corps
S3	Operations or the Operations Officer
SGT	Sergeant
TRADOC	US Army Training and Doctrine Command
TSP	Thrift Savings Plan
US	United States
USMA	United States Military Academy (West Point, New York)
USR	Unit Status Report
XO	Executive Officer
YG	Year Group

## CHAPTER 1

### INTRODUCTION AND OVERVIEW

The Army has some of the finest people in the world, but I'm worried about them. I'm worried about the ability to retain them after so many rotations to combat that their heads must be spinning.

Representative Ike Skelton,  
Chairman of the House Armed Services Committee  
(September 2007)

#### The Pending Crisis

When written in Chinese, the word "crisis" is composed of two characters - one represents danger and one represents opportunity.

John F. Kennedy  
(April 12, 1959)

The US Army could soon face potential danger because of a dramatic increase in the number of officers leaving the service after reaching the minimum number of years required to retire. A rise in the number of officers leaving the US Army would have a significant effect on the military and its ability to maintain high operational tempo. However, the opportunity exists to understand and apply resources before the problem becomes dire. To properly address this hypothesis, this thesis addresses how many officers the active US Army may anticipate losing over the next six years as these year groups begin to reach their 20 years in service.

Officers in year groups facing the most shortage, 1991-1997, will be surveyed and asked why they are leaving the US Army, and what can be done to keep them in past 20 years of service. This thesis will combine historical and current data including survey results to determine the degree of severity of the pending crisis of the officers in the

above year groups. The survey will be limited to the student population of active duty majors presently attending the 2008 Command and General Staff College at Ft Leavenworth, Kansas.

At 18 years of service, most officers start to consider when to retire. This assessment is often done with their families who, with the officer, have become worn down from the high operational tempo of the US Army. (Crist 2006). At 18 years of service, the Army Career Alumni Program (ACAP) sends a letter to each officer letting them know about services that are available to help them retire from the US Army and find a job in the civilian community. At 18 years of service, flight pay goes down for US Army aviators. At 18 years of service, Variable Special Pay goes down for dental and medical officers. At 20 years of service, members of the military may retire and receive 50% of their base pay for the rest of their lives and maintain many benefits from active duty. Although there are many incentives for the US Army officer to leave the service at 20 years, there is little officially being done to encourage officers to stay in past 20 years of service.

Much of the increased operational tempo of the US Army is directly related to the combat operations in Iraq and Afghanistan, but a certain amount can also be attributed to the current shortage of officers. With fewer officers, the officers in the US Army are deploying more often and have to pick up extra duties when not deployed. The total shortage of required US Army officers is 8%, representing a shortage of over 4,600 across all officer ranks. The media has focused on the shortages of lieutenants and captains (together as a group called company grade officers), yet 48%, over 2,200 (US

Army G-1 2008) of the total officer shortage is within the rank of major, the largest percentage for a single rank (see Figure 1).

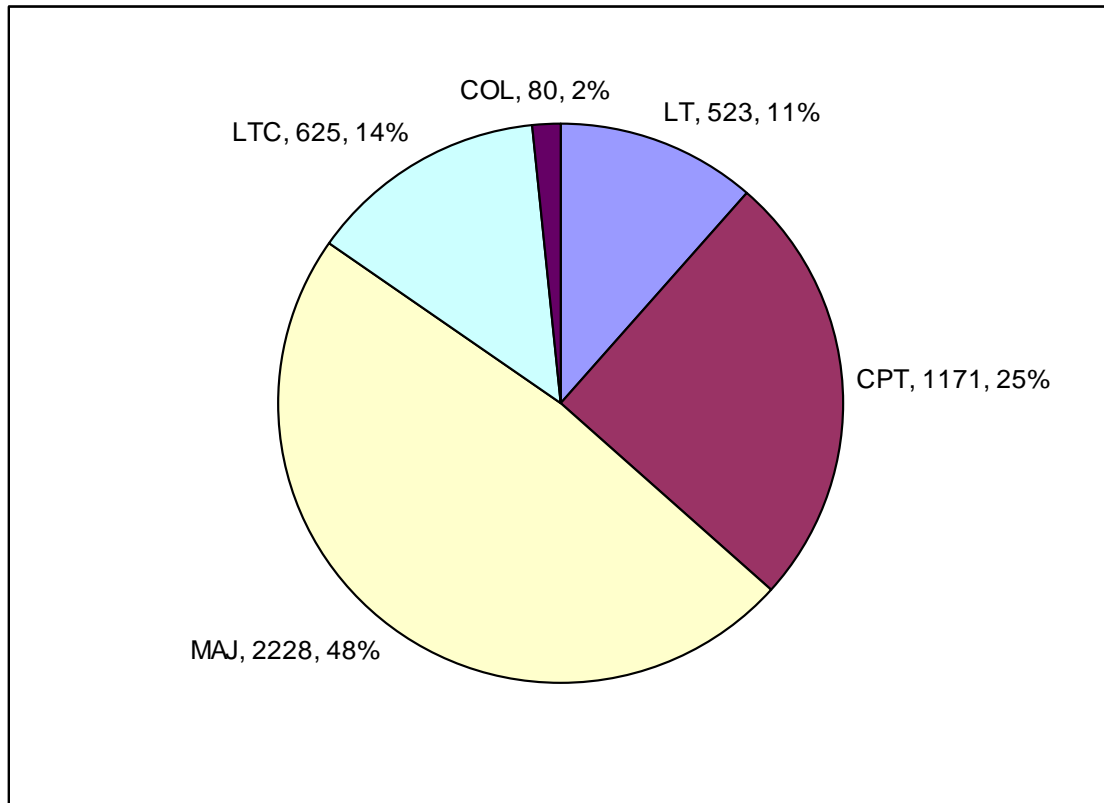

Figure 1. Shortage of US Army Officers as a Percent of the Total of Officer Shortages (US Army G-1 2008)

The US Army focus on company grade officers is an effort to fix the shortage of officers completing their active duty service obligations. However, in order to address the greater issue, something must be done with the more senior officers in year groups 1991-1997, mostly majors, as they begin to approach 20 years of service and are eligible to leave the service with retirement benefits.

Increased operation tempo and the military modular transformation following the 9/11 terrorist acts placed extraordinary strains on those officers who were commissioned

from 1991-1997 (called year groups); most of these officers are now majors. This thesis will examine this cohort to review the current and projected future shortages and propose measures that can be used to address this shortfall.

## How did the US Army Arrive at this Crisis?

Change is the law of life. And those who look only to the past or present are certain to miss the future.

John F. Kennedy

The US Army currently has a shortage of officers; most of this shortage resides within the rank of major. Within the next six years, this group will decide whether to continue to serve in the US Army beyond 20 years of service. Presently, nearly half of the branches are so understaffed in the rank of major that these branches would be considered not ready for combat using the US Army Unit Status Reporting (USR) system. (AR 220-1 2006) Any significant loss within these branches could be devastating.

This predicament was created as a direct result of the massive military drawdown in the early-to-mid-1990s when the US Army decreased its number of officers by 31% and under-accessed newly commissioned second lieutenants following the Cold War and coinciding with the end of OPERATION DESERT STORM. During this time, many lieutenants on active duty were involuntarily separated through Lieutenant Retention Boards. Captains were permitted to voluntarily separate prior to completing their active duty service obligations and were later offered relatively robust financial incentives under the Voluntary Separation Incentive (VSI) and Special Separation Benefit (SSB) programs. Officers opting for the VSI received an annual annuity for twice their number of years of service while SSB provided a lump sum payment. (Henning 2006) This

program seemed both logical and suitable in shaping the force to meet anticipated post Cold War requirements.

In addition to the massive military drawdown in the early to mid-1990s, recent factors also had a significant impact on the shortages of officers commissioned from 1991-1997. Beginning in 2004, the US Army increased the demand for active duty officers by 7,512 because of modifying the force structure of the US Army to a modular force (US Army G-1 2008); and in 2008, the US Army announced an increase in the US Army end-strength of 65,000 by 2010.

The percentage shortfall of the authorized number of majors is over three times greater than the percentage shortfall of the required number of all company grade officers (see Figure 2). Within the grade of major, there is a 17% total shortage of required majors (MAJ) versus a 5% total shortage of required company grade (CG) officers. (US Army G-1 2008) Even without an unexpected increase of officers leaving the service, the US Army G-1 predicts the shortage of majors to jump to over 20% by 2012. (US Army G-1 2008)

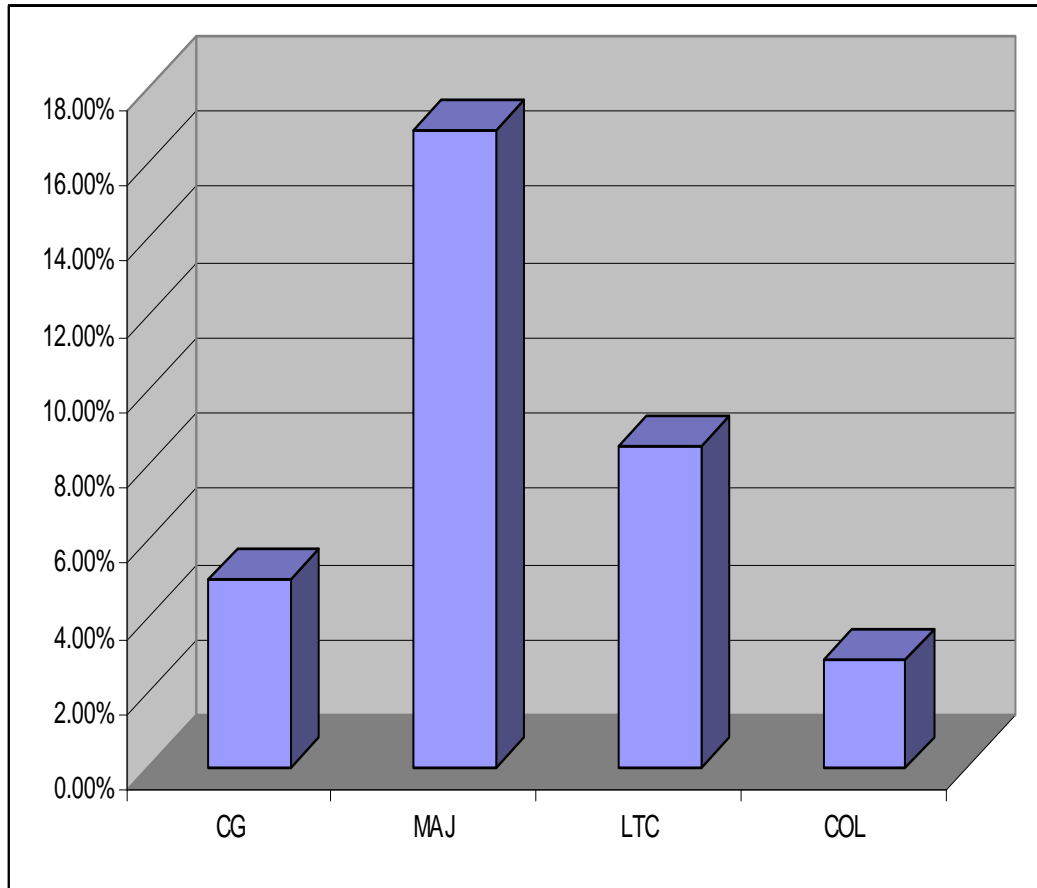

Figure 2. Shortage of Required US Army Officers, by Rank (US Army G-1 2008)

The percentage of majors leaving the service each year has increased since 1998 by 73% (from 3.75% to 6.48%) as shown in Figure 3. (U.S. Army G-1 2008) Each loss of 1% equals approximately 150 officers departing from the US Army. Reasons for these losses range from voluntary resignations to dismissals, and also include injuries and death from combat operations. Many of these officers have been able to retire with 20 years of service.

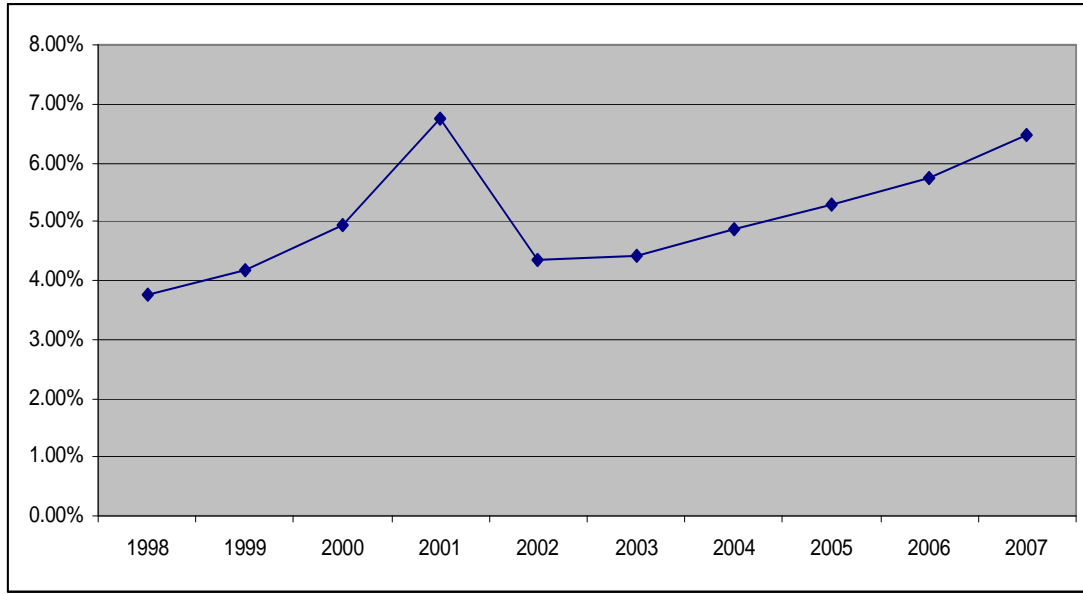

Figure 3. Percent of Majors that Leave the US Army Each Year (US Army G-1 2008)

A large number of officers in year group 1991-1997 will reach 20 years in service sooner than their year group peers because over 35% of these officers have prior-service experience (enlisted service time before becoming an officer is credited towards cumulative years) dating back to OPERATION DESERT SHIELD/STORM and OPERATION PROVIDE COMFORT in 1990-1991. This percentage is a significant factor not readily apparent in the current officer population. The example shown in Figure 4 illustrates how an officer with just three years of prior service will be eligible for retirement soon after promotion to lieutenant colonel.

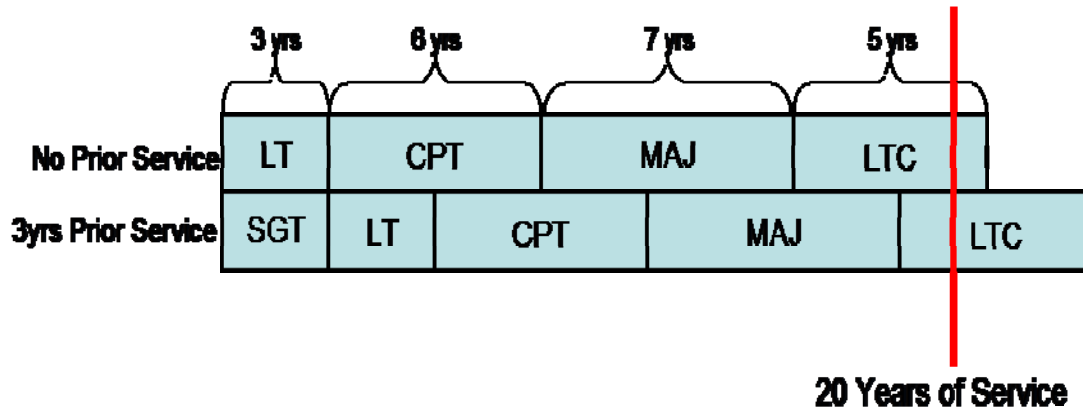

Figure 4. Officer Promotion Timeline (Army Regulation 600-8-29 2005)

Several recent surveys and government reports note that numerous officers leave the service sooner primarily because of the personal and family strains multiple deployments. One must not forget that Iraq and/or Afghanistan are most likely not the first of multiple combat deployments for these officers; the populations of officers in year group 1991-1997 of today were lieutenants and enlisted Soldiers during Somalia, Haiti, and the many missions to Bosnia and Kosovo.

A recent Government Accounting Office (GAO) report states that "DOD agreed that the Army does not have a strategic plan dedicated to current and projected officer accessions and retention." (Government Accounting Office 2007, 43) "The Government Accounting Office recommended that the Army develop and implement a strategic plan to address its emerging officer accession and retention problems." (Government Accounting Office 2007, cover page) Despite a few unsuccessful incentive programs, the shortfall trend continues and the "Army's ability to meet its future mission requirements and to transform to more deployable, modular units is uncertain." (Government Accounting Office 2007, cover page) Senator Chuck Hagel (R-Neb) noted in 2006 that "we're ruining an Army that took us 30 years to build." (Henning 2006)

Some broad steps at mitigating the total US Army personnel shortfall received support recently from the US Congress. In 2008, in recognition of the demands placed on the US Army, Congress increased the authorized end-strength of the Army by 65,000 personnel by 2010 (Tilghman 2007), of which 7,000 are officers. (HRC 2008) The US Army responded by increasing the number of lieutenants commissioned each year. However, increasing the numbers of newly commissioned officers in a relatively short period of time to address a change in end strength is not going to solve the current and projected shortage of needed senior officers (majors and lieutenant colonels). In other organizations, for example the State Department, an individual could join as a GS-14 (government position equivalent to a lieutenant colonel) based on education and experience. The US military does not have this type of program for most branches. It takes over 15 years to grow lieutenant colonels, so the loss of each lieutenant colonel is critical. The US Army must address the issue of retaining these officers on a phased basis and with a view of the ratios required to develop and retain an experienced force.

The US Army recently attempted to address the officer deficiency with several different programs. These include: (1) increasing second lieutenant accessions; (2) early officer promotions; (3) increasing the officer promotion rates (nearly 100% of the US Army officers are subsequently promoted from first lieutenant to captain, and 97% of the captains are promoted to major despite Department of Defense and Army guidelines that support 90% and 80% respectively per DA PAM 600-3); (4) graduate programs; (5) duty station of choice; (6) retention bonuses up to \$35,000 for captains; (7) recruiting retired officers to return back into the active service; (8) pulling officers from the Individual

Ready Reserve; and (9) inter-service transfer agreements with the Navy and Air Force under what is known as the “Blue to Green” Program. Unlike its sister services, the US Army has brought on about 400 officers who downsized into the US Army. (Peters 2007)

Each of these programs fails to reduce the growing trend of junior officers departing as soon as they reach their minimum service requirement (typically three to four years) and field grade officers (field grade officers are defined as officers serving in the rank of major, lieutenant colonel, and colonel) from leaving as soon as they achieve 20 years of service. In fact, most of the statistical information from HRC shows a slight increase in the percentage of company grade officers departing as soon as they reach their minimum service requirement and field grade officers leaving as soon as they reach 20 years of service. Although the HRC programs appear to have failed, the increase could have easily been significantly higher without these efforts.

Historically, the focus of officer retention by the US Army Human Resources Command and the US Congress appears to have been directed only towards the company grade officers. The US Army is now looking at two new programs to directly address the mid-grade officer shortage. The first program would expand the ability of the US Army to allow professional civilians to enter the service as a captain (new officers typically enter the service as a second lieutenant) in recognition of their experience and education. This program is already being used in the US Army and contributes a small percentage of the total officer corps (Aswell 2008) but is restricted to the legal, medical and chaplain branches. Another program under discussion at HRC is to allow select senior US Army officers the ability to promote a limited number of senior NCOs to captain. (Aswell

2008) Both of these plans, if approved, would allow an infusion of mid-grade officers into the US Army, but the total numbers would be relatively insignificant and only directly affect company grade officer shortages.

An influx of new officers is one method to address the shortage, but reducing the outflow of mid-grade officers also warrants attention. There are two significant exit points in the US Army officer system: (1) the loss of the junior officers after they finish their first term (typically after 3-5 years), and (2) the officers leaving after 20 years of service. The greater predicament is the loss of officers with 20 years of experience. This is where the shortage is most critical to the future leadership platform of the US Army.

The lack of incentives is another significant factor impacting the loss of officers from the US Army in cohort year group 1991-1997. These officers were not given early promotions or any of the other incentives given to the current captains and lieutenants. The lack of incentives is despite the fact that this group represents the largest shortfall of officers. Although this cohort will be the field grade officers needed to fill the positions in the expanding US Army, they are not currently included in any of the US Army's past, present, or future incentive models. This is not simply a case of "feeling left out." These year groups, as established earlier, represent a crucial pool of experience. This critical shortage of officers has been an "air bubble" (see Figure 5) in the officer manning system of the US Army that has been working its way through the ranks for more than a decade. Well over half of the branches are filled below 80% of required majors and several of the branches are already down to 70% or less (see Table 1). By US Army standards, fewer than 80% available would make a unit not mission capable for combat. (AR 220-1 2006)

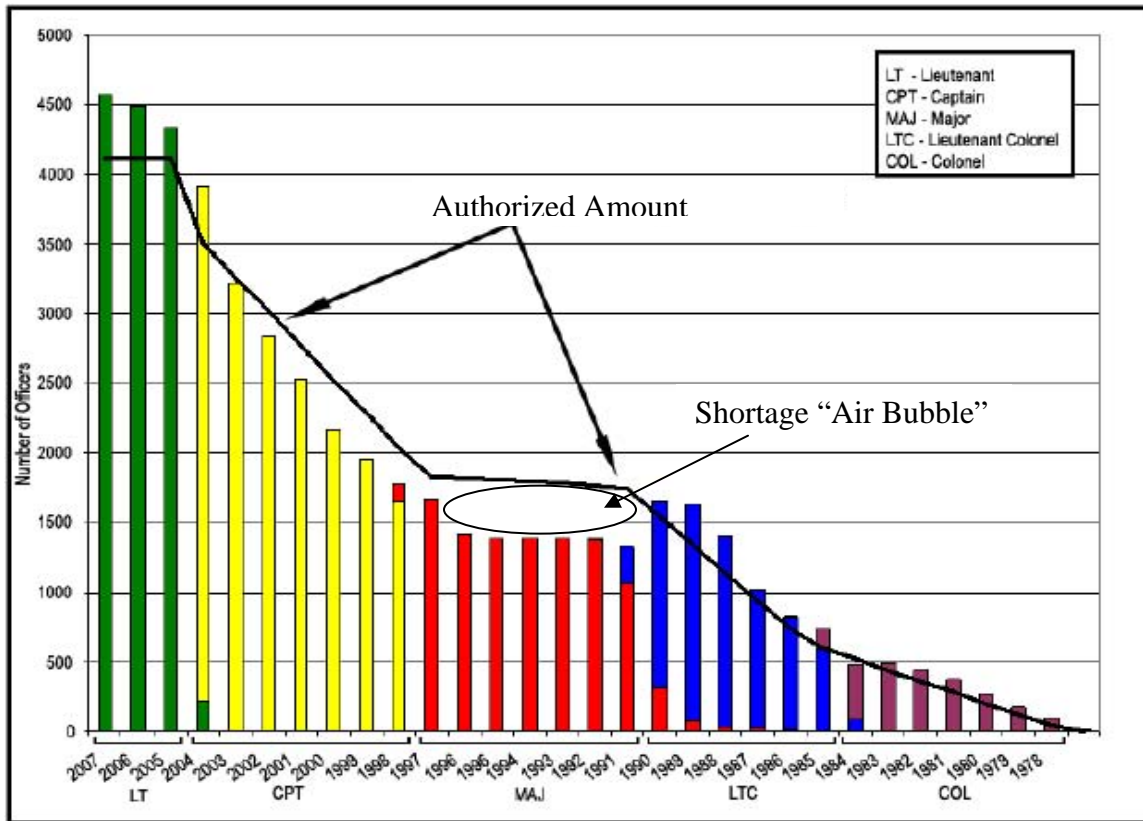

Source: Department of the Army.

Figure 5. Number of US Army Officers by Year Group (US Army G-1 2008)

Table 1. Army's Percentages of Overfilled and Under-filled Required Positions for Majors in Specified Branches for FY 2007

Basic branch	Percent of Authorized Strength
Infantry	107
Armor	99
Finance	98
Special forces	97
Adjutant general	96
Ordnance	88
Quartermaster	86
Signal corps	84
<b>Field artillery</b>	<b>79</b>
<b>Aviation</b>	<b>77</b>
<b>Military police</b>	<b>76</b>

<b>Basic branch</b>	<b>Percent of Authorized Strength</b>
<b>Chemical</b>	<b>75</b>
<b>Engineer</b>	<b>74</b>
<b>Military intelligence</b>	<b>73</b>
<b>Air defense</b>	<b>66</b>
<b>Transportation</b>	<b>48</b>
<b>Total</b>	<b>81</b>

<b>Special branch</b>	<b>Percent of Authorized Strength</b>
Medical doctor	99
Chaplain	91
Army nurse	86
Medical service	82
<b>Veterinary corps</b>	<b>78</b>
<b>Judge advocate</b>	<b>72</b>
<b>Medical specialist</b>	<b>67</b>
<b>Dentist</b>	<b>49</b>
<b>Total</b>	<b>85</b>

*Source:* GAO analysis of Army data 2007

It is clear that the severe shortage of field grade officers is a problem central to the US Army. The following chapters will discuss the history of the shortage, research/analysis of the future of the shortage and finally, recommendations on how to ameliorate this shortage and the pitfalls to be avoided in implementing a satisfactory recovery plan.

## CHAPTER 2

### HISTORICAL REVIEW

It is not the strongest of the species that survives, nor the most intelligent, but the one most responsive to change.

Charles Darwin

If you have always done it that way, it is probably wrong.

Charles Kettering

#### Background

The shortage of majors in the US Army did not develop overnight, yet there is incredibly little written on this subject. There were strong hints of it as early as 1999 when three of the ten US Army divisions reported that they were unfit for combat. The divisions had reported a C4 rating on their Unit Readiness Report (USR), a C4 being the lowest of four possible readiness scores. The low rating was mostly due to a shortage of training and equipment, but the mistake of drawing down the number of officers in the US Army too much too soon was becoming readily apparent.

The Government Accounting Office reports that another contributing factor to the officer shortage is that the US Army has routinely spent less than the Air Force, Navy and the Marine Corps on retention-related pays and incentives for officers (see Table 2).

The Government Accounting Office recently made the following observation:

The Office of Military Personnel Policy acknowledged that retention may have suffered because of an improving civilian labor market and the high pace of operations. Army officers may have already completed multiple deployments in Iraq and Afghanistan since the Army is the service providing the majority of the personnel for those operations. Another reason why the Army may be having more difficulty than other services in retaining its officers could be related to its lack of continuation pays and incentives. (Government Accounting Office 2007, 29)

Table 2. Retention-related pays and incentives for officers in 2006  
(emphasis added)

Dollars in thousands	
<b>Service</b>	<b>Total</b>
<b>Army</b>	<b>13,591</b>
Marine Corps	18,707
Navy	129,273
Air Force	202,536

*Source:* Government Accounting Office 2007

The Army's retention-related pays/incentives for officers were about 11% of the Navy's and 7% of the Air Force's expenditures. This lack of financial incentives is made starker by the fact the US Army is much larger in size than any of the other US service branches.

The US Army compensation system has remained virtually unchanged for over half a century. Today's structure is just as it was after World War II. Compensation continues to be provided based primarily on a "one size fits all" approach where longevity of service and rank remains the key determinant of service members' salaries. In short, today's compensation package for the US Army lacks the flexibility to meet the full range of current requirements, especially the ability to retain skilled military professionals. (Eaglen 2008)

In addition to the fixed antiquated salary structure, there is an observable negative consequence on retention of officers due in part to the prevailing perception by service members that those serving in the military are underpaid. This became evident in recent reports which suggest that service members do not value deferred benefits as highly as cash compensation. (Warner 2001) The GAO concluded that the current mix of compensation is highly inefficient for meeting near-term retention needs. (GAO 2005)

Each year, there is a “Personnel Statement of Military Compensation” published comparing US Army jobs to compatible civilian jobs. Service members often find the statement hard to understand and confusing. A recent GAO focus group found that 90 percent of service members underestimate the true value of their compensation, and 80 percent believe they would earn more in a civilian job. (GAO 2005)

An emphasis on non-cash and deferred payments continues to contribute to the perception of a military–civilian "pay gap," even though, arguably, the military reports none exists. The perceived “pay gap” is partly because more than half of military compensation is in non-cash benefits (see Figure 6). The *Tenth Quadrennial Review of Military Compensation* report also refuted this opinion, concluding that "military pay for both enlisted personnel and officers is about the same or higher than the earnings of comparable civilians." (Tenth Quadrennial Review of Military Compensation 2008) The difference is that members of the military only see the published salaries being given to their civilian counterparts, but do not have visibility on the out-of-pocket expenditures by their civilian counterparts for services that are included in their military benefits.

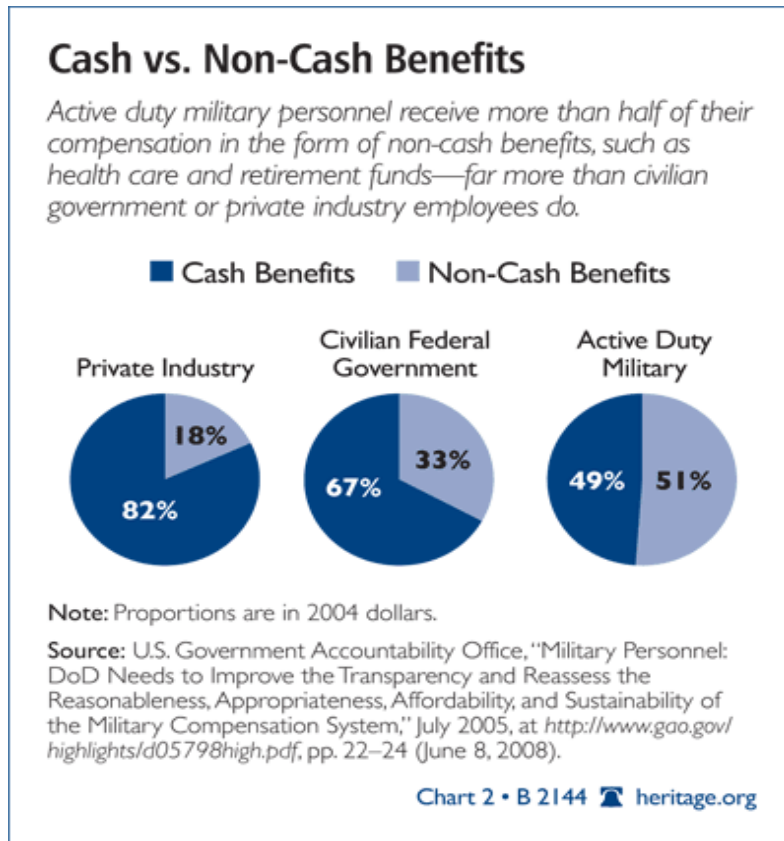

Figure 6. Cash vs. Non-Cash Benefits (Heritage 2004)

Although there is technically no “pay gap” between the military and civilians in private industry, what are often not considered are the inherent dangers of being in the military. Perhaps a better comparison of the “pay gap” is to compare what American civilians are being paid in Iraq doing similar jobs similar to US Army Soldiers in Iraq. According to data provided to the House panel, the average per-day pay of personnel Blackwater hired was \$600 (see Figure 7 for total cost of one Blackwater security guard). According to the schedule of rates, supplies and services attached to the contract, Blackwater charges taxpayers \$1,075 a day for senior managers, \$945 a day for middle managers and \$815 a day for operators. (Pincus 2007, A17)

## LAYERS OF COSTS

Here's a look at one small item in the war in Iraq: the daily cost of one security guard for a food convoy.

<b>Jerry Zovko</b> Security guard from Ohio	PLUS	\$600/day
<b>Blackwater</b> North Carolina security company	PLUS	\$215/day plus all expenses*
<b>Regency Hotel</b> Kuwaiti middleman	PLUS	Overhead and profit
<b>ESS</b> German food contractor	PLUS	Overhead and profit
<b>Halliburton</b> Texas general contractor	PLUS	Overhead and 2% profit
<b>TOTAL</b>		<b>To be paid by U.S. taxpayers</b>

\* Room and board, insurance, travel and all overhead

Source: Blackwater contracts, LOGCAP contracts

The News & Observer

Figure 7. Example of the Cost to Hire One Security Guard From Blackwater (Neff 2008)

In comparison, US Army General David H. Petraeus, Commander, Multi-National Force–Iraq, overseeing more than 160,000 U.S. troops, makes roughly \$180,000 a year, or about \$493 a day. That comes out to be less than the \$600 Blackwater pays for its senior manager of a 34-man security team. (Pincus 2007, A17) US Army officers in the Military Police branch would not compare their pay scale to a policeman with the same responsibilities in Chicago; the standard US Army officer compares his/her pay to a Blackwater (or similar contractor) employee that is doing the same occupation with the same responsibilities in the same dangerous location, and away from their families for many months at a time. However, the comparisons that appear each year (e.g. in Army

Times) do erroneously make the direct comparison to the police officer in Chicago. This is the “pay gap” or more correctly, the “compensation gap” that does exist.

The spouses of these officers are also weighing in on the decision to get out; overlooked in the compensation calculations is a complete family focus. There is a popular t-shirt slogan that sells well on post, it reads: “Military Spouse: The Toughest Job in the Military.” The military member’s pay also must compensate for the loss of income from their spouses. These officers marry smart, competent, career-capable partners, but given it's next to impossible for the spouse to also have a viable career with frequent military moves while effectively single-parenting during deployments. It may not be about the money, but these spouses are comparing their family life to brothers, sisters, and friends from college (cars, houses, quality of neighborhood schools, etc). If the compensation doesn't keep pace at a family level, in addition to stresses of military service, the spouse is most likely to cast her/his vote to get out. (Tyson 2008, comment)

In 2006, the shortage of officers in the US Army was seen as critical by the Congressional Research Service, who project the issue may become worse.

While specific skill shortages and imbalances have been reported by the other services, only the Army is reflecting service-wide active component shortages. The Army currently projects an officer shortage of nearly 3,000 in FY2007, with the most acute shortfalls in "senior" captains and majors with 11 to 17 years of experience. For example, the Army considers any personnel "fill rate" (the number of officers available to fill requirements) of less than 85% a "critical" shortage and projects a fill rate of 82.6% for majors in FY2007. The Army further projects an increased shortage of more than 3,700 officers the following year, and estimates that annual shortages in excess of 3,000 officers will persist through FY2013 unless accessions can be increased and retention can be improved. (Henning 2006, Summary)

In light of this information, the US Army, in 2006, implemented a pre-commissioning program allowing cadets to select a branch, post, or graduate school for an additional service obligation of three years. This program proved successful; 1,100 participated in FY06 and 1,600 in FY07. The Army expects this program to reduce loss rates among U.S. Military Academy (USMA) and ROTC scholarship commissioned officers beginning in FY10 when these officers will have completed their normal active-duty service obligation (five years for USMA and four years for ROTC officers). Now these officers will be retained for eight and seven years, respectively. USMA cadets may agree to serve three years beyond their five-year obligation; scholarship ROTC cadets agree to serve their four-year obligation plus an additional three years of active duty service; and non-scholarship officers agree to serve their three-year active-duty obligation plus an additional three years. (US Army Posture Statement 2008)

The US Army started a campaign in 2007, backed by hundreds of millions of dollars from Congress, in an attempt to retain junior commissioned officers. These are the officers who have only been in the active military for a few years. This is a continuing effort to address the shortage of the future, but it does nothing to address the shortage of senior officers now, and for the next six years. Army leaders are responsible for providing for the development of leadership skills of all their subordinates. The real question arises: who will develop the junior officers if there is no one available to guide them?

The US Army officer retention program centers on retaining mid-grade captains to stay in until 10 years in service; the goal of the program is to get the officer to the point where he/she is close enough to retirement to decide to stay in until 20 years. “In the last

four years, the exodus of junior officers from the Army has accelerated. In 2003, around eight percent of junior officers with between four and nine years of experience left for other careers. Last year, this same attrition rate leapt to 13 percent. A five percent change could potentially be a serious problem," said James Hosek, an expert in military retention at the RAND Corporation. "Over the long term, this rate of attrition would halve the number of officers who reach their tenth year in uniform and intend to take senior leadership roles." (Tilghman 2007)

In response to the RAND Corporation report and others, the US Army initiated an Officer Retention Menu of Incentives on September 13, 2007, to target retention of Army Competitive Category and selected Medical Service and Army Nurse captains. This initiative allows most of the Army's captains in the year groups 1999 through 2005 the opportunity to select a branch of choice, post of choice, military school, advanced degree, or Critical Skills Retention Bonus (ranging from \$25,000-\$35,000) in exchange for an agreement to serve three additional years past any existing service obligations. The US Army estimates that it can retain an additional 2,300 officers above its normal retention between now and 2009 through these incentives (HRC 2007).

Progress of the captain retention program is not meeting expectations. Typically, the US Army loses 9-12% of the captains each year, yet a recent Defense Military Data Center survey indicated that 52% of captains polled intended to separate or were undecided about continuing in a military career. The Officer Retention Menu of Incentives program encouraged fewer than 70% of the eligible officers to stay in a total of one to three years; only 54% took a menu incentive with an additional three years of

service attached and will now continue to serve until at least FY 2011. (US Army Posture Statement 2008)

The program persuaded 11,933 captains to commit to additional Army service, short of the 14,184 goal. The military will pay out more than \$349 million in bonuses to the officers who took the incentives. All told, 67.6% of those eligible for the program -- which offered officers cash bonuses of as much as \$35,000, the ability to choose their next assignment or military-funded graduate school -- agreed to serve an additional one to three years in the Army. The military had hoped that 80.5% of the eligible captains would extend their time in the Army. (Dreazen 2008)

If one assumes that the officers who did not accept the incentive leave the US Army as soon as they finish their initial service obligation, then the data predict an even greater trend of captains leaving from today's high of over 12% to perhaps over 30%! (US Army Posture Statement 2008) One of the errors in this cash bonus program was the amount of money given to officers who most likely would have stayed in without the bonus. Each year, the US Army loses between 9-12% of captains; therefore, the Army offered bonuses to approximately 90% (historical trends) of the officers who would have stayed in without the program. The defect in this program was that it did not target the captains considering leaving the Army; the incentive was offered to every captain. Because less than 68% of the officers signed up for this incentive program, it can be surmised that the Army gave the majority of the money to the captains who had already decided to remain, and perhaps did nothing to change the minds of the officers who had decided to leave the service. It is also possible that more captains would have left the service without the menu of incentives; therefore the menu of incentives potentially averted a much greater crisis.

A better method of retaining captains might be targeting captains by offering them the opportunity to change branches, with an obligation of an additional three years of service. The officers with job satisfaction would not be interested in this, but this option has the potential to retain hundreds of junior officers at virtually no cost to the US Army. In practice, not all requests could be filled. Perhaps a choice of duty station could be arranged for these officers. This program would need management above the branch offices. The obvious negative is the potential of many officers requesting to leave branches that are already critically short. This could be addressed in the same manner that critical enlisted jobs are: target these officers with cash bonuses.

Another defect in the current incentive program is the amount of money offered. Traditionally, the Army will give an enlisted Soldier a cash bonus equal to a year of pay when the Soldier holds a specialty and rank that are critically needed. The maximum cash amount offered to the captains was equal to about one-half of a year's pay; this amount (before being taxed) was not enough to persuade a captain, who has already decided to leave the military, to stay in; in fact, many of the junior officers noted that no amount of money could convince them to continue their service. (Aswell 2008) A brigade commander in Iraq was recently quoted on the issue:

The main message from our junior officers is that their service is not about financial gain. . . . They want recognition for their performance and want a competitive [personnel] system that rewards top performers. Such competitiveness is impossible to achieve when nearly all officers through the rank of lieutenant colonel are virtually guaranteed a promotion - a situation that is rapidly becoming the norm. (Peters 2007)

Perhaps a better use of the hundreds of millions of dollars spent on the captain retention program would have been spent more wisely on dispersed and long-term targeted programs such as a monetary bonus to entice more senior officers to serve more than 20 years (see Chapter 5).

While the above perceptions of easy promotion are prevalent in today's Army, the leadership opportunities and high level of responsibility of the US Army cannot be matched in the civilian sector and most officers will not have the occasion to discover this until after they have already left the service. In recognition of this, the US Army HRC has adopted some programs that allow officers previously released (ETS or retired) from the US Army to return with the same rank.

### Military Retirement Program

Understanding the retirement programs currently offered to US Army members is imperative to fully comprehend why many officers desire to stay in until completion of twenty years of service. It is also significant to know why many will comment that “working past twenty years of service is the same as working for half your base pay”. Under normal circumstances, no retirement pay is given to the service member that has served less than 20-years of active-duty service. After serving 20-years there are a few methods to calculate your retirement funds. If a Soldier entered active duty after 8 September 1980, the base pay received in retirement is the average of the highest three years of active duty base pay received (known as the “high 3” program) with an additional 2.5% per year after 20 years of active service. For example, a person who entered active duty after 8 September 1980, and spent 22 years on active duty, would receive 55% of the average of the highest 36 months of active duty base pay. (Powers 2008)

There is another retirement option for individuals who joined the military on or after August 1, 1986. These individuals are required to make a decision at the 15-year point of their career and can elect to participate in the same retirement program above or they can choose to receive an immediate monetary bonus (\$30,000) for the "REDUX" system. If they elect the "REDUX" system, the retirement percentage is determined by taking 2.5% percent times your years of service, and then reducing that factor by one percent point for each year less than 30 years. Using the same example as above, a person with 22 years of active duty service would retire at 47% of the average of their

highest 36 months of base pay. The "REDUX" ends at age 62, and the individual then begins to receive his/her "normal" retirement pay. (Powers 2008)

At twenty years of service, a typical officers would be a lieutenant colonel with a base pay of about \$88,473.60 a year, \$2,433.12 a year for Basic Allowance for Subsistence, and on average, \$22,000 a year in Basic Allowance for Housing (this is based on location) for a total of \$112,906.72 a year before taxes. If this officer retired, using the first program listed above, he/she would receive a retirement check of \$44,236.80 a year from the US Army until death (plus cost of living increases). To continue with the exact same standard of living, the next job for this officer would have to pay at least \$68,669.92 a year, or in other words; 60% of what this officer was making in the US Army. Thus the common saying in the military that continuing after twenty years of service constitutes "working for half-pay," is more accurately working for 60% of pay.

At eighteen years of service, the Army Career and Alumni Program (ACAP) transmit an email (see Appendix C) providing information to support the officer considering separation from the service. Although ACAP is an important service, a greater effort needs to be made to entice these officers to stay in past their retirement date of twenty years of service. The military retirement system, with the support of ACAP, encourages officers to leave as soon as they reach 20 years of service and virtually no effort is made to encourage these officers to serve past their minimum requirement time for retirement. The following chapters will discuss research methods to address this issue.

## CHAPTER 3

### RESEARCH DESIGN

In times of change, learners inherit the Earth, while the learned find themselves beautifully equipped to deal with a world that no longer exists.

Eric Hoffer

You got to be careful if you don't know where you're going, because you might not get there.

Yogi Berra

Initial research for this thesis began with statistical data from open sources and from the US Army Human Resources Command. Raw data includes the number of officers required and sourced by the US Army by rank, year group, and branch over the past twenty years. Information was also gathered on the number of officers who leave the service each year, also by rank, year group, and branch over the past twenty years. Months of analyzing and scrutinizing the data were performed by the author to determine the exact status of required, sourced and lost officers by year and to determine the current status of the US Army officer corps. Minor discrepancies were discovered between published charts (for example: Government Accounting Office Reports) and the raw data from the US Army Human Resources Command. These discrepancies were resolved by using the raw data from the US Army Human Resources Command. Most of the illustrations have been created exclusively for this thesis from this raw data in order to present consistent and impartial assessment.

Historical trends are helpful in predicting the future of the US Army officer corps. For example, one could surmise that if the number of majors and lieutenant colonels

leaving the US Army over the last 10 years continues in the same pattern, that there will only be a moderate increase in the number of these officers leaving the US Army over the next four years (see Figure 8).

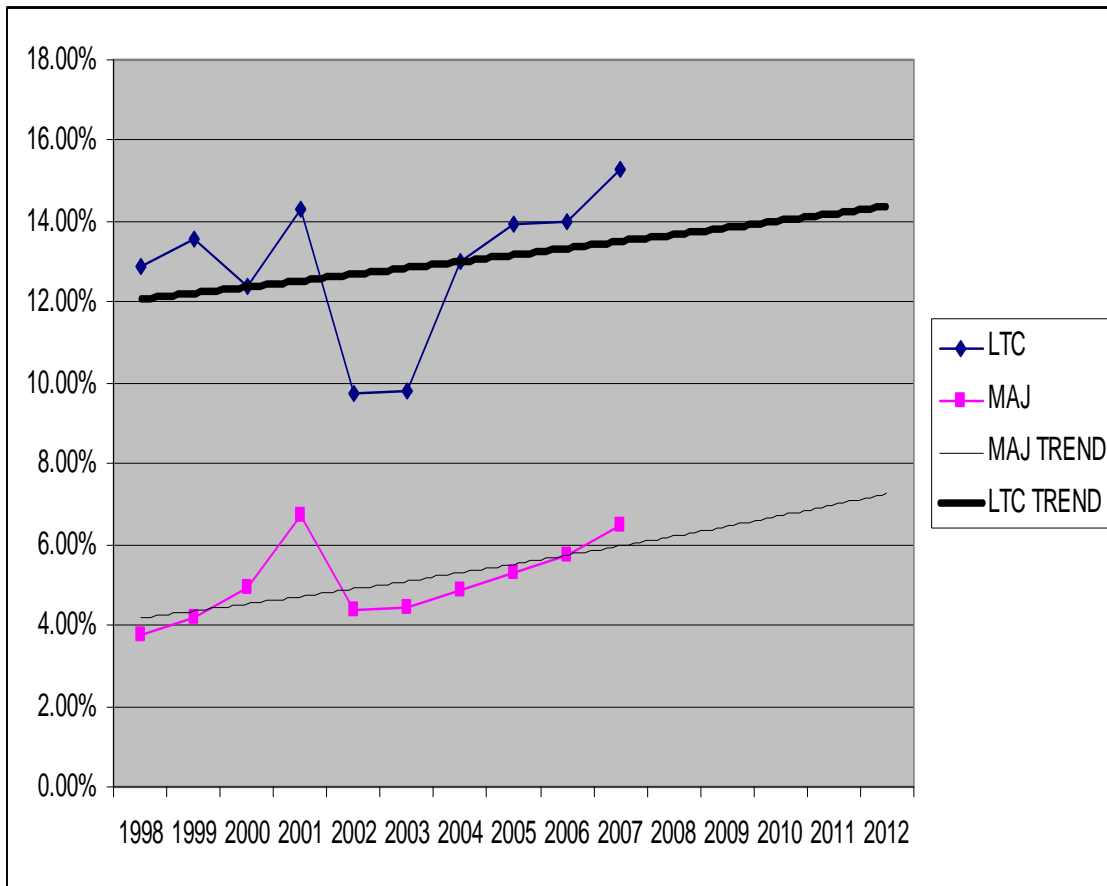

Figure 8. Trend of the Percent of Majors and Lieutenant Colonels Leaving the US Army Each Year (US Army G-1 2008)

But reviewing trends is only a basic way to predict the future, and does not have the ability to predict new trends from other variables. For example, the data prior to 2002 does not include the variables of “stoploss” and multiple deployments. One cannot predict the future but you can however ask intentions. Therefore, a superior method to

determine future trends for this thesis is by conducting a survey of current officers. A survey gives the ability to not only determine the plans of these officers, but to also find out the thinking behind their plans and what might be able to affect these plans.

Coordination was made directly with the CGSC Quality Assurance Office and Army G-1 office (manpower distribution office) to determine what survey information existed on predicting the future shortage of US Army active duty majors. This information was used to determine what additional information was needed to answer the following questions: 1) How many majors can the active US Army expect to lose over the next few years as the officers in their year groups start to reach their 20 year mark in the service? 2) Why are these officers leaving the US Army? 3) What can be done to keep these officers in past 20 years?

The best method to answer these questions was to conduct a survey of the readily available US Army active duty majors. The total number of active duty majors in the US Army in 2008 is 15,706 but the survey was limited to surveying only the active duty majors attending CGSC in classes 08-01 (AUG07-JUN08) and 08-02 (FEB08-DEC08) at Fort Leavenworth, Kansas. In total, 780 US Army active duty majors were in CGSC and were sent surveys via email invitation. Out of the 780 majors, 412 responded giving the survey a confidence level of over 95% (Taylor-Powell 1998) and a confidence interval of +/- 5% for a population size of 15,000. Online surveys typically have a 2-30% response rate (Statistical Survey 2008) and the survey for this thesis had a response rate of 53%. This response allows for an accurate assessment of the views of all the basic branch majors in the US Army today.

The survey is designed to first indicate when officers will leave the US Army, by demographics, including branch, year group, prior service time, marital status, children, and number of recent deployments. These demographics were used to determine common ideas among like groups and to identify ways for targeting incentive programs. The survey also attempted to address the core reason each officer was planning on leaving the service and also what may encourage the officer to stay in longer than planned. The assumption is that officers tend to make career decisions based on three key reasons (in no particular order): (1) family; (2) personal; and (3) professional. The survey questions were designed to indirectly determine these key factors in the officers' decision making process. The results of the survey (results can be found in Appendix A) are also compared to current statistical information from the US Army Human Resources Command within each branch to determine trends. The next chapter will analyze this information.

## CHAPTER 4

### ANALYSIS

Man has two supreme loyalties - to country and to family...So long as their families are safe, they will defend their country, believing that by their sacrifice they are safeguarding their families also. But even the bonds of patriotism, discipline, and comradeship are loosened when the family itself is threatened.

General William T. Sherman

History does not long entrust the care of freedom to the weak or the timid.

Dwight David Eisenhower

#### Analysis

Currently, 20% of the officers who become eligible to retire at 20 years of service are leaving the US Army. (US Army G-1 2008) The survey data generated in this research indicates this percentage could increase within the next four to six years to as much as 60% of the total number of officers eligible to retire with the minimum requirement of 20 years of service. To exacerbate the shortage issue, the percentage of officers with the intent to leave the service promptly upon reaching 20 years is proportionally higher in branches that presently have the fewest required number of majors. A positive highlight of the survey is that less than 8% of those planning to leave the service at 20 years or less noted that nothing would keep them from retiring later than the minimum requirement of 20 years. Therefore, 92% of the officers could possibly be convinced to stay past their planned retirement at 20 years, with the proper incentives.

The following charts show the predicted sequence of the worst-case shortage of

officers from 2010 to 2014. The figures posted below start with the HRC assumption that by 2010 the US Army will be manned to almost 100% of the required lieutenant colonels. (The actual HRC numbers place LTCs at 96% by 2010 and 99.5% by 2012). Other factors used in the charts include: (1) officer year groups (1991-1995) each have 1,400 officers and will experience losses before reaching 19 years of service due to prior service officers retiring before their peers, discipline terminations, and losses due to disability or deaths; (2) the survey conducted for this thesis suggests that up to 60% of the officers will retire as soon as they reach 20 years of service, 4% at 21 years, 9% at 22 years, and 4% at 23 years; and (3) the numbers in charts posted below do not account for the requirement of 500 more lieutenant colonels expected by 2010 which would imply an even larger shortage of officers than depicted in the charts.

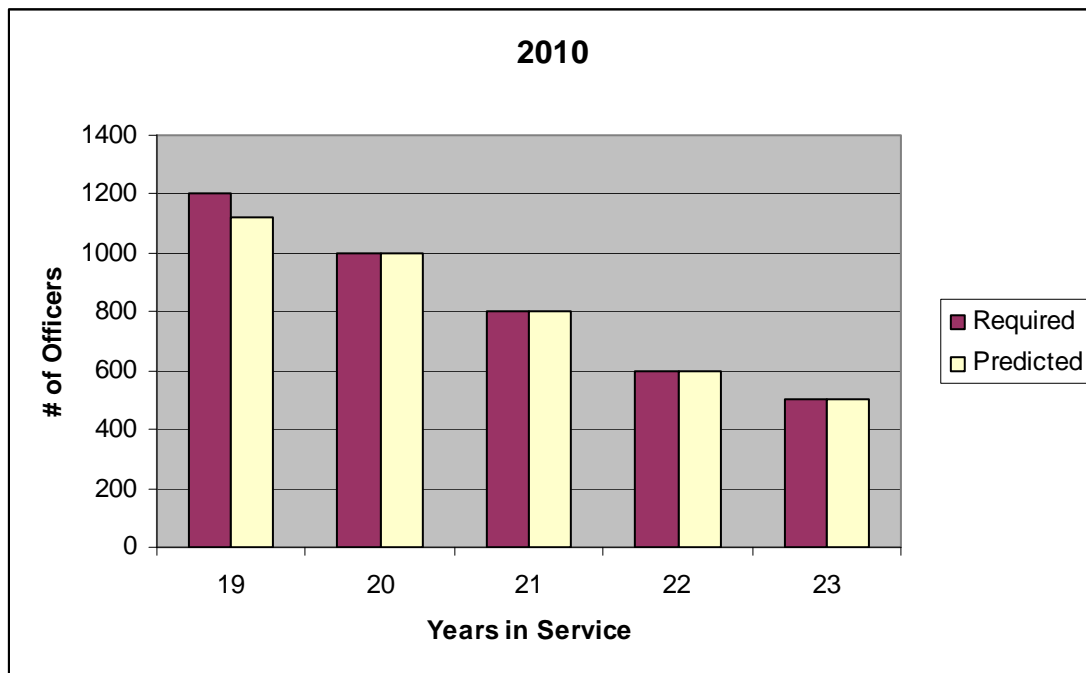

Figure 9. Required vs. Predicted Number of Officers in 2010 (Source: Author)

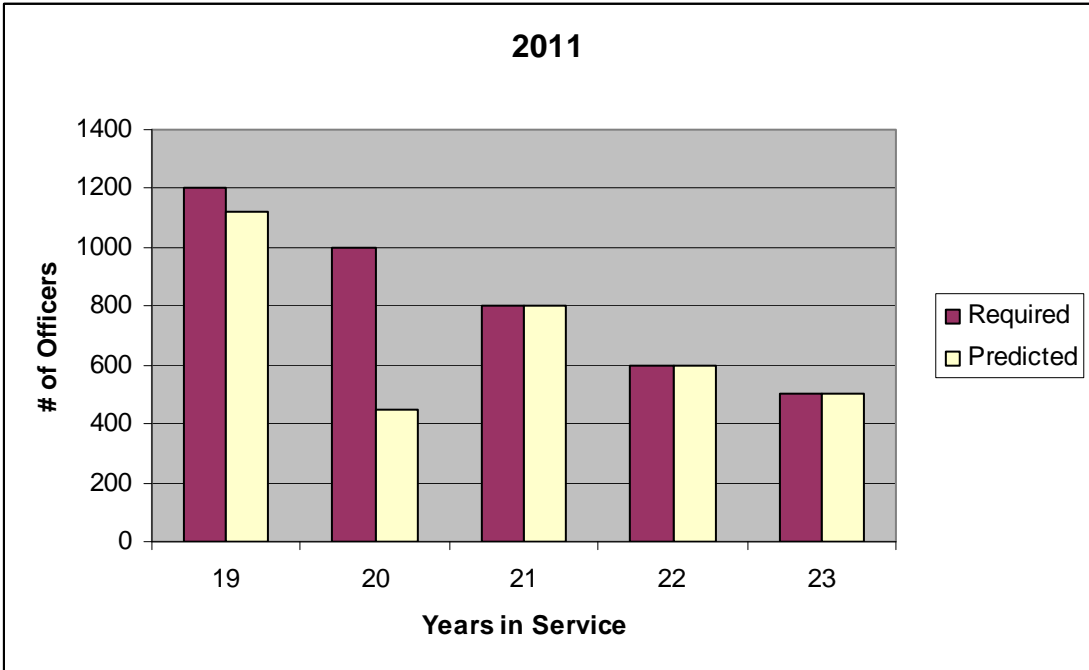

Figure 10. Required vs. Predicted Number of Officers in 2011 (Source: Author)

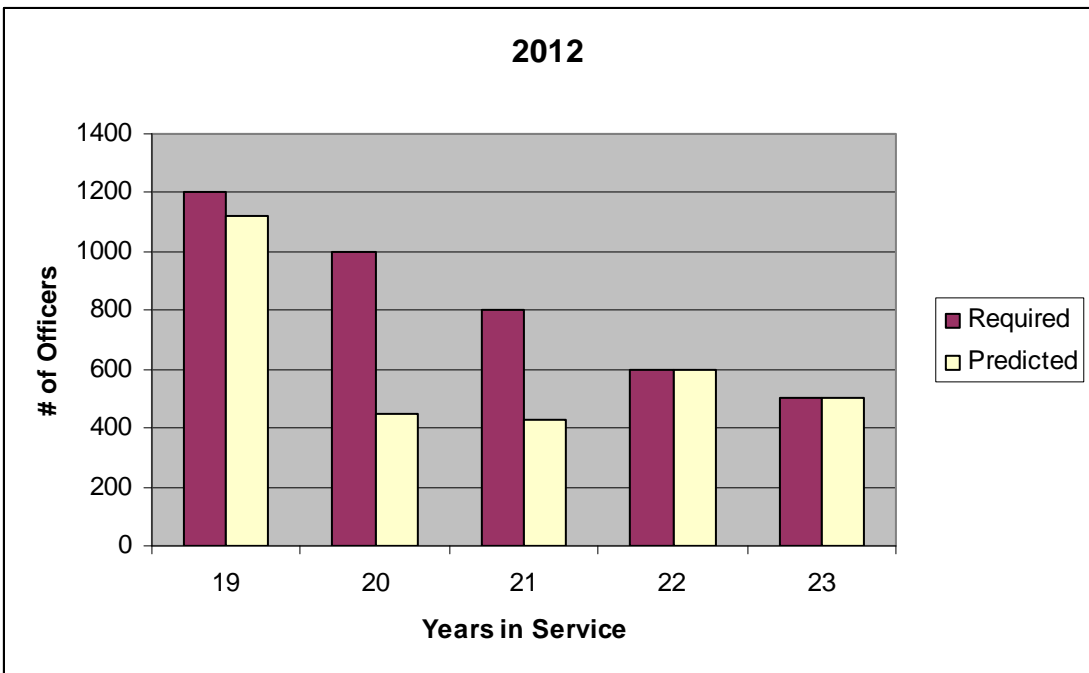

Figure 11. Required vs. Predicted Number of Officers in 2012 (Source: Author)

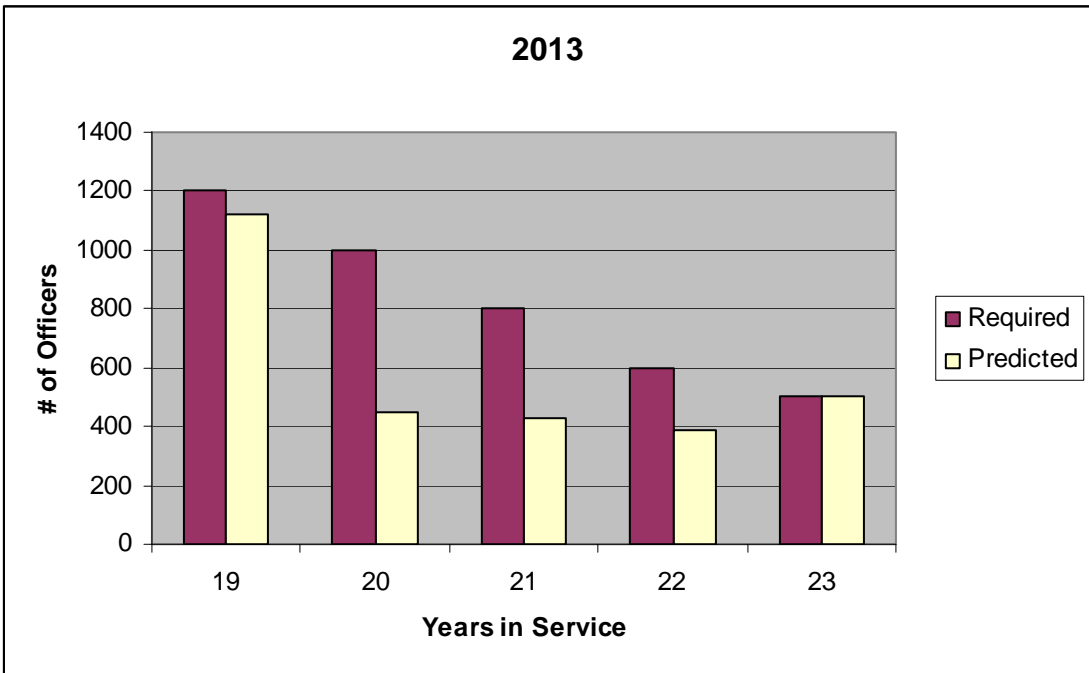

Figure 12. Required vs. Predicted Number of Officers in 2013 (Source: Author)

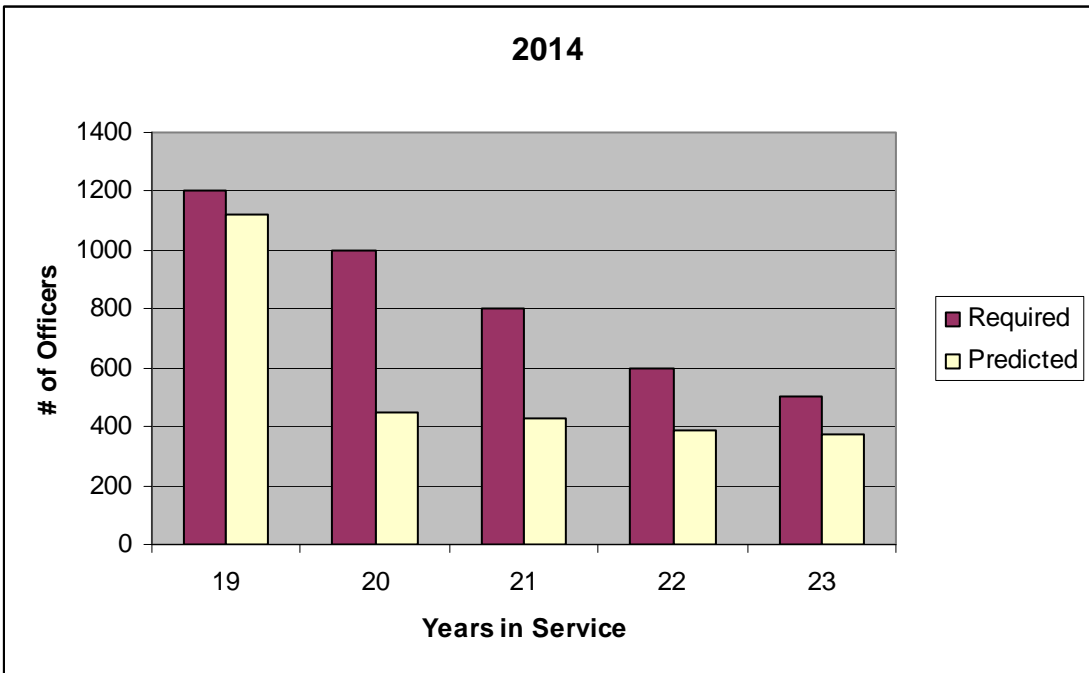

Figure 13. Required vs. Predicted Number of Officers in 2014 (Source: Author)

The survey conducted for this thesis predicts that by 2014 the US Army will be short well over 50% of officers who are serving between 20 and 23 years. The vast majority of officers in these year groups, by 2014, will be the lieutenant colonels. The most critical aspect of this 30% shortage of lieutenant colonels is that it is not equally distributed across all of the branches. Most of the US Army officer branches, by 2014, will likely face shortages greater than 50% of their requirement for lieutenant colonels. This branch data will be more closely examined in the next section under “Statistical Information from Specific Branches of Note.”

The officers surveyed tended to make career decisions based on three key reasons: family, personal, and professional. Family needs are the overwhelming key factor in the decision of the surveyed officers to stay in the US Army or not. Yet the most popular reason for enticement to stay in the Army longer was not based on family needs, but rather it was the desire for capital. A direct bonus payment of one-year base salary for an additional three years, after 20 years of service, was the most popular choice in the survey. This appears to be a contradiction in terms, but not if one assumes that the financial incentive would be used to support the family or if a large enough financial incentive is more important than family needs.

Another statistic of interest is the percent of officers who have served more than a year of time as an enlisted Soldier. Majors in this survey are over 35% prior-service; this is an indicator that more officers will leave sooner than their year group peers. Of the officers who plan on leaving the service at 20 years or sooner, 27% were prior-service, or in other words: 77% of the total number of prior-service officers surveyed do not plan to

serve more than 20 years. Therefore, the common wisdom that prior-service officers typically only serve 20 years of total service is proven in this survey.

Surprisingly, there was no significant difference between those who plan to leave the US Army in 21 years or less and those who plan to stay in for more than 21 years, in the categories of marriage, children, and number of deployments.

The last question on the survey asked the respondent taking the survey for any additional comments. This comment box limited responses to only 500 letters or spaces and allowed the officers unrestricted opportunity to express individual thoughts related to or excluded from the survey. Of the 93 comments (see appendix B), 40 were specifically positive or negative towards the US Army with 88% being negative and 12% positive. This pessimistic attitude among some of the majors was an alarming discovery. The optional comments from the survey ranged greatly, but a few common trends emerged (see Table 3). Because this was an optional and open ended question, no specifics were derived from the answers given.

Table 3. Trend of Comments from the Survey

38%	The US Army does not take care of family needs
29%	Dissatisfaction with monetary compensation
20%	Believe that operational tempo (workload) is too great
19%	Disappointment in the senior leadership
17%	Lack of opportunities for professional development
11%	Lack of education opportunities (self and family)
10%	Displeased with the number of relocations

- 10% Will stay in until 20 years, only because of time already invested
- 6% US Army has invested in junior officers, but not the field grade officers
- 5% Upset with substandard military housing

The comments posted match closely to the other survey data collected, but also added an additional look into the potency of the negative opinions held by active duty US Army majors. The bluntness of the remarks was surprising, even given the anonymity of the survey. Examples included: “Staying in isn't worth the headache anymore;” “we did our time and served our country during difficult times and maybe its just time to take care of our families;” “Army gives lip service to taking care of soldiers in a lot of areas;” “we seem like the Army owns us because we are near retirement;” and “I hate the Army.”

The comments reinforce the majors’ discontent with how they and their families view their treatment by the military and their desire to leave the service. This insight into the inner-thoughts of these officers is important. The importance of this data is not just in reinforcing the results of the survey, but also reveals a view into the private conversations among these officers and their peers and families. Additionally, these opinions may spill over and influence junior officers. Generally, commissioned officers tend to have a positive attitude towards the US Army, but the tendency appears to be turning negative after reviewing the comments given in the survey.

Similar survey results were published in June 2006 by a spouse of a CGSC student for Central Michigan University. The survey data was collected from 150 spouses of Army Majors who were attending CGSC at Fort Leavenworth, Kansas during Academic Year 2005-2006, Class 06-01. (Crist 2008) Of those surveyed, 55%

responded that their spouse plans to retire from the US Army with 20 years of service or less. The survey also identified that nearly two-thirds of the respondents said they have previously considered leaving the Army citing the following factors (in this order): better opportunities in the civilian job market, Operations Tempo (OPTEMPO) in garrison, quality of on-post housing, OPTEMPO in the field, quality of leadership at their duty station, and the amount of military pay (to include bonuses). According to the survey, spouses are also heavily influenced by the following factors when supporting their Soldiers to continue serving the Army (in this order): retirement benefits, service to the Nation, Soldier's job satisfaction, job security, medical care benefit, and travel opportunities.

### Statistical Information from Specific Branches of Note

The greatest danger for most of us is not that our aim is too high and we miss it, but that it is too low and we reach it.

Michelangelo

In general, the branches in the US Army are filled to an average of 83% with typically 20% of the officers leaving after serving the minimum amount of time for retirement, 20 years. In total, officers from 27 branches were surveyed for this thesis. Listed below are the branches that had enough officers responding to make an assessment and that also have the worst current and projected situations. The branches facing the direst conditions are listed first.

The Transportation branch has the greatest shortage of majors with a fill rate of less than 50%. Of the transportation majors that responded to the survey, over 92% plan on leaving at 21 years of service or less and 15% plan on leaving before reaching 20 years of service. Of all the officers surveyed, 50% of the majors planning on leaving before 20 years of service were from the transportation branch. The Air Defense Artillery branch has only 66% of required majors and just under 70% of these majors plan on leaving at 21 years of service or less. The Engineer branch has 74% of required majors and 65% of these majors plan on leaving when they reach 21 years of service or less. The Military Intelligence branch has 73% of the required majors and more than 57% of these majors plan on leaving at 20 years of service; the Aviation branch has 77% of the required majors, but is projected to lose over 75% of the current majors when they reach 21 years of service or less. The Field Artillery branch has 79% of the required

majors, and is projected to lose over 73% of the current majors when they reach 21 years of service or less. The Signal branch has 84% of the required majors, and is projected to lose over 72% of the current majors when they reach 20 years of service. The Civil Affairs branch is perhaps one of the most critical specialties for Iraq and Afghanistan (the exact shortage could not be obtained for this thesis), yet 86% of these majors plan on leaving at 21 years of service or less; a total of 67% of the civil affairs majors leaving at 21 years of service or less are prior-service;. The Quartermaster branch has 86% of the required majors, and is projected to lose over 73% of the current majors when they reach 20 years of service.

This survey not only indicates an increase in the officers leaving after just 20 years of service from a historical average of 20% to a potential average of 60%, but also reveals a trend giving evidence that the branches with the largest current shortage of majors have the greater percentage of officers who plan on retiring sooner. This data implies that the shortage of officers within each branch may be part of the reason the officers are leaving. Therefore, the branches with the greatest needs have a situation that the survey suggests could become a great deal worse.

## The Future

America is at war, and we live in a world where global terrorism and extremist ideologies are realities. The Army has analytically looked at the future, and we believe our Nation will continue to be engaged in an era of “persistent conflict”- a period of protracted confrontation among states, non-state, and individual actors increasingly willing to use violence to achieve their political and ideological ends.

(US Army Field Manual 3.0. 2008)

General William S. Wallace  
Commander, US Army Training and Doctrine Command

Based on the survey done for this thesis, 99% of today's majors will stay in until 20 years of military service to obtain retirement pay that is about half of their base pay. Historically, officers retire several years after reaching this 20 year mark, but the Army's Human Resources Command (HRC) is presently reporting an approximately 50% increase in the number of retirements of majors and lieutenant colonels since 2003. The loss of majors is up from 4.35% in 2002 to 6.48% in 2007 and the loss of lieutenant colonel is up from 9.76% in 2002 to 15.27% in 2007 (see Figure 14).

This number of losses will continue to be supported by the 36% of prior-service officers in year groups (YG) 1991-1997, identified by the survey conducted for this thesis. This percentage of prior-service officers may be attributed to cadets with prior-service often being chosen by the US Army over those without prior-service because of their experience during the military reduction in the 1990s. Perhaps prior-service cadets were also chosen for active duty to help with retention. These officers were most likely, in theory, to stay in the service after their initial requirement. The presumption is that officers with 3-5 years of prior-service time before becoming officers would have 7-9

years of total service time invested in the US Army by the time they finish their initial contract time as an officer. Therefore, an officer would be halfway towards retirement at the first opportunity to leave the service. Conversely, these same officers will reach 20 years of service before their peers in the same year group (see Figure 4).

Experienced, and predominantly married, field grade officers are under pressure to make career decisions against a backdrop that demands their skills and services in the private sector. Many officers and their families deliberate among themselves whether the rewards and benefits of a US Army service career are enough to compensate for the extreme sacrifices inherent in the US Army of today. They see their civilian peers going home to their families every night, while they look forward to repeated deployments to a combat zone. The appeal of a stable family life and job, often including an enhanced compensation package with an entirely different working environment, often proves attractive. Family separation is the single greatest disincentive facing the US Army, as recognized in the survey conducted for this thesis.

One of the most significant concerns is the remaining majors will soon take this critical shortage into the next rank of lieutenant colonel (see Figures 9-13). Lieutenant colonels are the battalion commanders and senior staff members of the US Army. The loss of these officers could move this critical shortage from a hardship to an incapacitating element in the US Army's ability to accomplish missions the nation requires. COL Paul Aswell of the US Army HRC officer management section noted that this shortage is an issue the US Army G-1 cannot quickly fix. The rationale from HRC is that the shortage of majors is due to the fact that the US Army is expanding in size within all ranks. The senior ranks can not be filled until the junior officers, just entering the

service, have enough time in service to make the promotions to fill the new positions.  
(Aswell 2008)

When asked about the impending deficit of lieutenant colonels (due to the major "air bubble" of officer shortages) and officers to fill battalion command slots, COL Paul Aswell surmises that even if 90% of the officers left at 20 years of service, there would still be enough lieutenant colonels to fill the demands of the US Army. (Aswell 2008)

This may not be completely accurate. The fact is, although the lieutenant colonel shortage is not yet as critical as the shortage of majors, lieutenant colonels are already under-strength by 8.5%, and the number of demands for lieutenant colonels will increase by 2% in 2010 due to the overall end strength expansion of the US Army. Historical trends show that about 12% of US Army lieutenant colonels leave the service every year. Without an increase of the historical trend of lieutenant colonels departing the service, the shortage of lieutenant colonels will decrease and equal the demand by 2012 (US Army HRC 2008). But, the percentage of lieutenant colonels leaving the service has increased, just as the percentage of majors. From 2003 to 2007 the US Army witnessed an increase in the rate of lieutenant colonels retiring from 10% in 2003 to 15% in 2007 (see Figure 14); this percent is the highest level in over 10 years. (US Army G-1 2008)

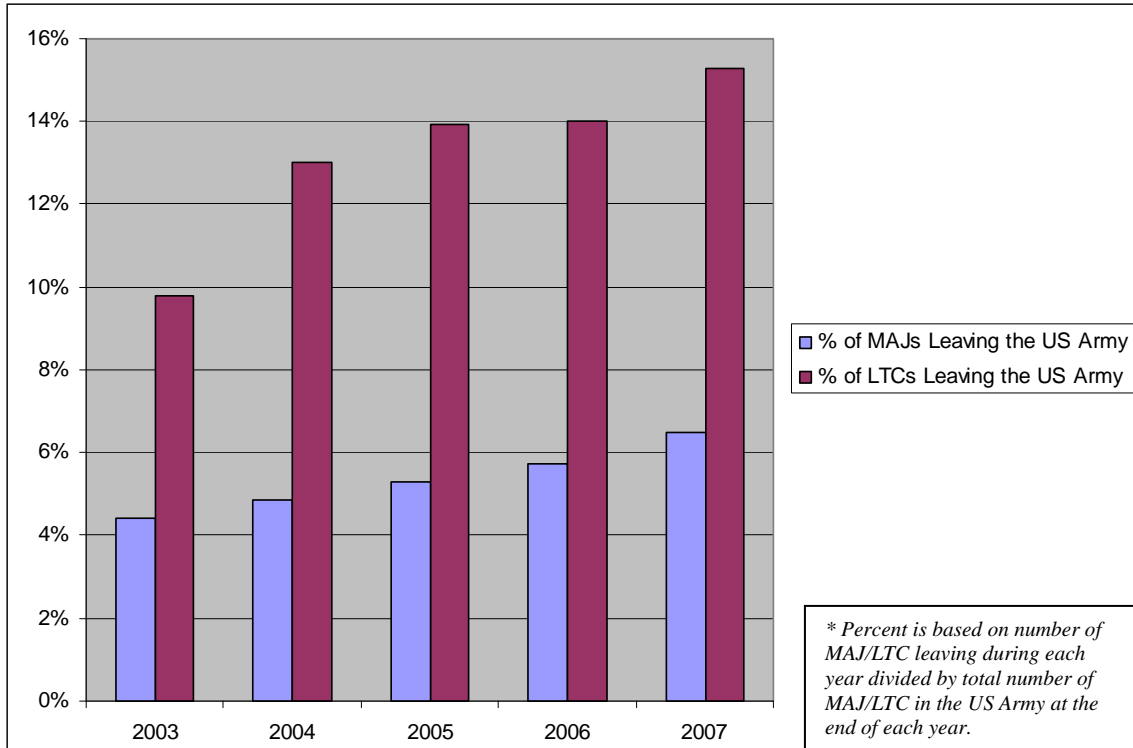

Figure 14. Percent of Active Duty Majors and Lieutenant Colonels Separating from the US Army (US Army G-1 2008)

If the number of officers departing continues to increase, as indicated in the survey conducted for this thesis (see Chapter 3), there will be an increase in the total shortage of lieutenant colonels from 8.5% in 2008 to more than 30% by 2014. This is based on the presumption supported by the survey that 60% of the officers in year groups 1991-1997 will retire after only 20 years of service, typically as LTCs. Each of these year groups has approximately 1400 officers, so a loss of 60% would leave each year group with only 560 officers. The US Army depends on having at least 1000 LTCs to stay in past 20 years of service, 800 to stay in past 21 years of service, and 600 past 22 years of service. These numbers do not factor in the increased demands for 7,000 more officers required by the increased US Army end-strength due by 2010.

This survey not only indicated a likely increase in the number of officers leaving after just 20 years of service, but also a trend giving evidence that the branches with the largest shortage of majors have the greatest percentage of officers who plan on retiring at 20 years. This deficiency will increase in the branches that are already operating at actual fill levels less than 70% of the authorized lieutenant colonels. The US Army is currently compensating for the shortage in many of the branches by shifting manning requirements for branch immaterial (01A) assignments from the branches with the greatest deficiency to the branches whose numbers are not as dire. (Aswell 2008)

Lieutenant colonels command battalions and serve in key staff positions, but they are also the direct senior mentors to junior officers. “Officers in the grade of lieutenant colonel serve as senior leaders and managers throughout the Army providing wisdom, experience, vision, and mentorship mastered over many years in uniform.” (DA PAM 600-3 2007) Without quality mentors, the entire professionalism of the US Army officer corps suffers. This tipping point perhaps could be the most destructive aspect of the officer shortage.

A significant number of these field grade officers will be needed to stay in past 20 years of service to fill the current shortages and to support the expanding end-strength until the large number of junior grade officer accessions can catch up with the senior officer demand. The current 17% shortage of active duty basic branch majors and 8.5% shortage of active duty basic branch lieutenant colonels is a critical issue which, if not addressed by the Army leadership soon, will have a considerable impact on the military's capability to provide for the nation's defense and support the global war on terrorism.

During the most recent Senate Armed Services Committee hearing in February 2008, the Army Chief of Staff, General George Casey, noted that the US Army's goal is to speed up the military personnel expansion and add 43,000 total troops by 2009 and 22,000 more by 2010 for a total of 547,000 for the active duty Army. General Casey stated that "(we) must sustain our Army ... retaining is our top priority." (C-SPAN 2008) But according to the Congressional Budget Office, "if recruiting and retention does not improve from 2005 levels, the Army's end strength will actually decline." (Tighman 2007, 1) During the same hearing, Senator Joe Liebermann (I-CT) noted that he did not think 547,000 active duty Army Soldiers will be enough (C-SPAN 2008). Therefore, the shortage may be an even bigger problem.

There is clearly a need for the US Army to develop and implement a plan to encourage more officers to stay in past 20 years. The ability to grow the US Army cannot be limited to increasing the number of new Soldiers and officers into the service. Logically, there must also be an effort to encourage the senior members of the US Army to stay in longer to properly lead this new larger force. Therefore, the US Army must work doubly hard to preserve the finest and brightest in the military because so much has been invested in these extremely capable officers.

### Thesis Limitations

Colonel Paul Aswell, chief of the officer division for HRC, spoke about the officer shortage: "In the Army there has never been anything like this in memory" and former Army Secretary Francis J. Harvey was quoted "we are worried" on the same subject. (Tyson, 2007, A01) Not every aspect of this issue could be covered in this thesis. Listed below are some of the topics that fell outside the scope of this paper.

There are a few anomalies within the shortage of officers for some branches. The majority of the shortages of majors are related to the military drawdown of the 1990s, yet the branches of infantry, armor and finance are currently all over 98% their required strength. This thesis was unable to explicitly address this topic. One theory is that these officers have a higher level of job satisfaction early in their careers or that the combat officers see the current war as a rare chance to actually do their job that they have spent years training to do. This theory is rationalized by the assumption that the officers who left the US Army from the other branches were not satisfied. The survey of majors in this thesis did not reach officers who have already left the service; therefore, no defensible answer is available. Although the percent of these officers in the branches of infantry, armor and finance who are planning leave the US Army at the minimum requirement for retirement is below the overall average of this survey (60%), all three of the branches have a predicted loss of over 50% at 20 years of service or less.

In addition to the projected losses of officers leaving the service after 20 years, there is also the attrition of officers killed during combat operations. For example, as of 1 June 2008, in Iraq there has been a loss of 98 US Army captains, 26 US Army majors,

and 17 US Army lieutenant colonels. (USA Today 2008) The branch information of these officers was not available for this thesis.

Another cause for an officer to leave the military is due to pregnancy. This thesis did not track the number of officer that left for this reason. An officer who becomes pregnant is not required to leave the military, it is a voluntary resignation. Those officers who still owe obligations due to schooling, incentive pay or funded programs are not eligible for release until completion of service obligation.

Other sources of the loss of officers include accidents (mostly from auto accidents, classified as “Class A” by the US Army Combat Readiness/Safety Center); death by natural causes; and being forced to leave the US Army because of disciplinary issues. Although these numbers are calculated in the overall loss rate, this thesis was unable to determine the exact percentage of these officers versus the number of voluntary resignations.

Only the current shortage of majors and the projected shortage of lieutenant colonels are discussed in detail in this thesis. The issue with the shortage of company grade officers was not fully addressed. The US Army is not commissioning enough second lieutenants from the US Military Academy (West Point) and the Reserve Officers' Training Corps programs. Although this problem may not be as critically important at the moment, it has potential to become a major crisis for the US Army. In 2006, 846 cadets graduated from West Point; the goal was 900 (in 2007 and 2008 West Point met goals). In the same year, there were 25,100 enrolled in ROTC out of a goal of 31,000, according to a report by the Government Accountability Office. (GAO, 2007) Without a proper influx of officers into the US Army, it will be more difficult to encourage majors

and lieutenant colonels to stay in past 20 years in order to keep the military at the proper manpower strength under an all volunteer system.

The survey conducted for this thesis was only able to reach active duty basic branch US Army majors attending the Command and General Staff College. The Command and General Staff College is a ten month course that is available for all of the basic branch majors in the US Army, yet adds two years to an officer's service obligation to the US Army. Because of this additional commitment, the assumption is that officers, who have already decided to leave the service within the next two years, would most likely not attend this school. These officers would most likely be those who have five years or more of prior service credit and who are within two years of the minimum requirement for retirement of 20 years. This premise was not tested in this thesis.

## CHAPTER 5

### CONCLUSIONS AND RECOMMENDATIONS

Readiness remains, unequivocally, our number one priority.  
It affects and is affected by everything the Army does.

Togo D. West, Jr.  
Secretary of the Army (93-98)\*

The nation's resources available for defense are limited, but the uncertainties of today require a ready force capable of responding quickly and decisively to protect our nation's needs.

General Dennis J. Reimer  
Chief of Staff of the US Army (95-99)\*

*\* Ironically, these are quotes from the leaders of the US Army during the massive drawdown in the 1990s that left the US Army with the officer corps hollow of majors.*

#### Conclusions

There are risks and costs to a program of action. But they are far less than the long-range risks and costs of comfortable inaction.

John F. Kennedy

There is a critical shortage of US Army active duty officers. This shortage is most significant within the rank of major and is going to become worse within the next rank of lieutenant colonel as a significant number of these officers decide, at historically high levels, to retire immediately at 20 years of service. These officers are not disgruntled, but are tired, frustrated and starting to leave the service. Persuading these officers to stay in longer is imperative, but currently, there is surprisingly little being done. Some analysts believe that the projected shortages of majors and lieutenant

colonels will result in critical positions being vacant or filled with more junior and less experienced officers or even noncommissioned officers. This lack of experience could have a negative impact on unit readiness or cause some officers to fill more than one position simultaneously. With the current operational and deployment tempo, this additional stress could result in higher attrition and, therefore, a worsening shortage situation. (Henning 2006) The branches with the greatest shortages have the most worn down officer corps because of the extra work having to be done to make up for the shortages. These are the officers most likely to leave the service, only to make the problem worse in the branches in the direst situations. So the problem is in turn making the problem worse.

The United States will always need a strong military; the exact size may be argued, but a tipping point towards failure is approaching when the US Army does not have adequate officers to lead and staff its mid-grade positions. The US Army may not be broken yet, but it is bending a great deal as junior officers are increasingly filling positions that require an officer of senior rank or filling multiple positions.

COL Paul L. Aswell, chief of the officer division for HRC, spoke about this situation in 2007.

We have to ask ourselves, 'Is it the war? Is it the back-to-back deployments?' For him, the question has personal resonance. My son is a 2002 graduate of the U.S. Military Academy, and he's had four tours in Iraq. His friends have served multiple tours in Iraq and Afghanistan. One friend has served 42 months in Iraq since June 2002. . . . That has to have some effect in the future. What's not amazing is that these officers get out. What's amazing is that so many of them do stay in. (Peters 2007)

Many officers speak of family issues as the reason for leaving the US Army; even so the right size monetary incentive, offered along with a menu of other, non-monetary incentives, could target enough officers to curb the growing crisis.

As the nation continues to fight two wars, unpopular both nationally and internationally, over an extended period of time, while attempting to expand the US Army in size, there will be manpower issues. Consequently, the overall security of our nation depends on the senior military and civilian leadership recognizing these issues before they become critical and reach proportions beyond what can be quickly fixed with resources at the disposal of the US Army. On 7 October 2008, the United States entered its eighth year of major combat operations in the global war on terrorism, making this the third longest war in American history after the Revolutionary War and Vietnam. (Stringer 2008) It is likely that the US Army has already reached a major officer shortage crisis in at least several of the branches.

The officer shortage is obvious and the situation is becoming substantially worse. More senior-level discussions on this topic are required and swift action is necessary. The longer the US Army takes to seize the opportunity for action, the fewer options and assets the US Army will have time to implement. The state of affairs of the US Army and the defense of America are at risk.

## Recommendations

If you want to make enemies, try to change something.

Woodrow Wilson

It doesn't work to leap a twenty-foot chasm in two ten-foot jumps.

American Proverb

Something must be done to address the issue of the officers in year groups 1991-1997 from retiring *en masse*. There are three categories of effort where initiatives can be made in the short, near and long term: conduct an information campaign (short term); formalize incentive programs already in use (near term); and create monetary bonus programs similar to those used for enlisted Soldiers (long term). Other more drastic options are available to address the shortages, but the second order effects may be too harmful to the US Army.

Doing nothing would be to depend on the military retirement program to maintain the proper number of officers in the US Army. The military retirement program and opportunities for command have been historically successful in retaining enough officers to enable the US Army to turn away nearly half of the officers seeking battalion command. This percentage is drastically changing as the officer shortage (the "air bubble" shown in Figure 5) continues to work its way through the system. As a result, the US Army may soon not have enough lieutenant colonels to fill all critical positions. Nevertheless, the retirement program has been proven to work and will continue to encourage many officers to stay on active duty, but more needs to be done. New programs to bring in mid-grade officers from the civilian population or NCOs could be

helpful, but only on a limited scale. The key is to promptly focus/target on retaining the officers planning to retire over the next seven years with 20 years of service until the programs to retain company grade officers start to have an effect on the requirements for field grade officers.

### Information Campaigns

Initially, officers with 18 years of service should receive a message from the US Army explaining the benefits of staying in the service. With so much information being sent to the officers supporting them in retiring from the service, and offering jobs, there must be information from the US Army to allow the officers to make better, more educated decisions. Additionally, senior leadership in the US Army should reach out to the officers approaching 18 years of service or sooner and take part in the edification process. Addressing the majors at CGSC would be an example of a quality forum where this process could begin. Another example would be to have the first general officer in the chain of command personally and regularly meet with at risk officers to mentor and counsel them on the very good career opportunities the military offers and to give them a sense of organizational belonging. (Stringer 2008)

Tangible peer narratives should also be used in an information campaign to retain officers. Consider the example below from a posting on a professional military blog by a US Army major:

...I enjoy my job in the military a lot. I loved being a platoon leader and company commander. I even enjoyed some of my staff assignments because they were rewarding, but I am sure glad that I have job security being a member of the U.S. Army and don't have to be one of those employees from Lehman who were seen walking out of the building on a Sunday afternoon with all the stuff from

their desk in a cardboard box or carry-on suitcase; another point you can use when your subordinates are contemplating separation from the military. Also, feel free to use my 15,000 reasons why not to get out of the Army in one minute speech. This (\$15,000) is what it cost for my wife to have an emergency appendectomy while on day 8 after returning from Iraq; thank God for Tricare. It may not be the best but it is definitely not the worst either. I always told my subordinates that they need to prepare for the worst at any given point. I offer this up to those who are thinking about getting out. (XO/S3 Net 2008)

This type of illustration should be used with others to form the core on the information campaign. This intervention should also occur directly via senior management—general officers—to preserve their future leadership cadres. A personnel officer who did this for then-Captain Eric Shinseki saved a transformational Army Chief of Staff for the force. (Stringer 2008)

### Formalize Incentive Programs

The Human Resources Command has many informal incentive programs that could be better utilized if publicized and controlled by one centralized section. One example would be to allow officers to change branch immaterial assignments, across branches. These options would be at no cost to the US Army but would require additional manning at HRC dedicated to run this program. The system today requires officers and HRC to haggle for assignments. This negotiation may require the officer to submit their retirement request before being considered for a requested assignment. Although this is a method for HRC to target officers, it is not a centralized process allowing all officers fair and equal considerations. A centralized process is not much

different than the current system of competition between the officers for certain schools and promotions.

### Monetary Bonus Programs

The majority of the officers surveyed in this research agreed that monetary incentives of varying types would convince them to stay in the US Army longer. A one-year base pay cash bonus for three years of service was the most popular option in the survey. A monetary bonus, in the correct amount, and targeted to the branches that are critically short, is undoubtedly an effective method for the retention of the officers to stay past 20 years of service. Using a monetary bonus is helpful, not only because the value of non-monetary benefits is not easily recognized by personnel, but also because a system that favors monetary benefits would enhance the freedom of each officer to decide how best to use his/her benefits, thus increasing the value of those benefits. (Eaglen 2008)

The current compensation system is heavily skewed toward non-cash and deferred benefits and is typically not well explained to the average member of the US Army. A modern annual compensation review should be mandated for members of the US military that is common across the services. This report would clearly outline each member's benefit programs and include the annual cost to the US government for many in-kind benefits that are included in total compensation costs. (Eaglen 2008) This report would be sent individually to each service member, similar to the mailings from the Social Security Agency. This report could be a step toward countering the idea that the “grass is greener on the other side” when compared to civilian counterparts.

A monetary incentive system for critically needed officers would put salaries in a better light because these officers often compare their pay levels with those of their civilian counterparts, easily forming the false impression that they are underpaid when simply comparing pay stub amounts. The Department of Defense does a poor job of formally and regularly telling service members and their families about their total compensation. (Eaglen 2008)

The one-year base pay bonus for three years of service over 20 years would be one option to provide a monetary incentive to officers in branches that are critically short. This bonus program was the most popular in the survey conducted in this research, and is already common practice with enlisted US Army Soldiers. An average of 1,400 officers reach 20 years of service each year. At 20 years of service, most officers would be at the rank of lieutenant colonel with a base pay of \$88,473.60 a year. This bonus program would equal a yearly maximum cost of just under 124 million dollars, even if every officer was given this bonus after reaching 20 years of service. The cost of the captain retention program was almost three times this amount and one-year base pay is a common bonus to enlisted Soldiers in critical jobs. The cost of this program would be much less if only the officers in the shortage branches and eligible for retirement were targeted. Another way to think about the cost of this bonus program is to recognize that the US Army is short approximately 15% of its authorized strength of majors and 8.5% lieutenant colonels. That means that part of the budget set aside to pay these officers salaries is not being used. In theory (and practice), 85 majors are working harder to do the job of 100 majors, and not receiving any extra pay. That 15% of the salary from majors could fund bonuses, or other incentives, for those who are working harder than

ever. This assertion might be an oversimplification, but the premise is sound. (Philman 2008) The US Army is short 2,228 majors for a savings to the US Army of over \$210 million. This bonus program could be used to target specific branches, but would require a change in federal law to facilitate this option.

Matching funds for Thrift Savings Plan (TSP) is another monetary bonus, less costly, but slightly less popular in the survey compared to the cash bonus. This program would allow officers to give up to 10% of their base pay to the TSP and have it matched by the Army after they reach 20 years of service. With about 9,000 officers serving past 20 years at an average annual pay of just under \$100,000, the program could cost the US Army \$90 million each year if every officer took full advantage of the system. The military already allows service members to invest in the TSP but with no eligibility for matching funds. The eligibility is there in law, but DoD and the services have not made use of it except in a few test cases. The federal employee system already allows civilians to contribute to TSP and their contributions are matched up to 5% by the US Government; the first 1% is placed in the fund, whether or not you contribute any of your own money.

#### Less Desirable Options

Over half of the majors in the survey conducted in this research are currently planning to leave the US Army because of family needs and a desire to settle down in one place. The officers feel they are not supporting their family because of all the time spent away on deployments. These officers could be encouraged to stay in past 20 years with a job in a non-deploying unit that will ensure stability for at least three years. The officer

could be taken off the command track, but would still be able to fill critical positions required by the US Army. This program would directly address the issue many officers have with not spending time with their families, and the cost of this program would be almost nothing. According to the research, for this nominal cost, up to 17% of the officers who plan to retire at 21 or 20 years of service could be retained. This program is already being used informally by some HRC branch officers (ROTC / Recruiting / Installation / AGR / TRADOC / MACOM (or above) Staff / Functional Area Job). A significant drawback of this incentive is it would not be available to every officer because the US Army still needs many of these officers for combat deployments. This plan would be a good program to offer over-strength branches, but not practical for the under-strength branches in need of officers to deploy.

Another program popular in the survey is money for college. This program would persuade over 15% of the officers included in this survey to remain past 20 years of service. Most officers have a masters degree by the time they reach 20 years of service, yet the current policy of the US Army will not allow for funding of a second masters and offers limited opportunities for a doctorate. A program similar to the GI Bill and College Fund programs for enlisted Soldiers could be used, but with more flexibility. The program could grant one full year of college (BS/BA; MS/MA/MBA; PhD) for every year an officer serves past 20. This college credit could be used for the officer, or given to a spouse or child.

If the officer retention situation is allowed to deteriorate, the military will be forced to consider more undesirable options to maintain the leadership needed to run the US Army. One of these options is to increase the number of years it takes an officer to

reach retirement from 20 years to 22 years. A drawback to this decision is that it could be considered a breach of contract between the officers and the US Army. One of the best selling points to join the US Army is the 20 year retirement program. Not only would current officers lose trust in the military if this option were to be implemented, but many in future generations may never join. It is not because a 22-year retirement is terrible, but rather, if the military can change the rules to 22-years, who is to say the military might not change the policy again? Integrity is easy to lose, and incredibly difficult to recover.

Another undesirable option is to allow officers to stay in the service past their mandatory retirement date. Unfortunately, this program is already unofficially in effect as branches give out waivers for officers who cannot get promoted to stay in longer and allow the best and brightest to leave as soon as they reach their 20 years of service. The irony in this is that the branches in the US Army who use this approach have been given the tools to retain the very officers who should be out of the Army (passed over several times for promotion) but limited tools to maintain the best (those with critical skills being offered civilian opportunities).

The 10th Quadrennial Review of Military Compensation, a panel looking at military compensation, has recommended dramatic changes in the military retirement system. The defined benefit would be 2.5 percent of the average basic pay for the highest 36 months of the individual's career multiplied by the number of years of service, with service members vested at 10 years of service. Payments to retirees would begin at age 57 for those with 20 years of service or more and at age 60 for those with less than 20 years

of service. This program would take away the incentive and safety net that officers currently have when retiring at 20 years of service.

A few years ago, the US Army mandated that all majors receive Intermediate Level Education (ILE). The Command and General Staff School (CGSS) is a military school that currently takes about 1,200 majors out of the operational force for one year for the resident ILE course. The old system allowed only 50% of the majors to attend CGSS while the rest were required to conduct the training via correspondence. An undesirable option would be to revert back temporarily to the old method which would immediately make up to 600 majors available to cover many of the current officer shortages. Another variant to this undesirable method would be to temporarily restrict attendance to the ILE resident course to only combat arms branches. Both of these options would have undesirable long-term implications for the officers not allowed to complete the resident education offered at the CGSS.

The US Army also could consider moving from a volunteer program that allows retired officers to return to active service to a mandatory return for officers in critical branches. This program would be a limited draft, only by another name. The US Army is already using involuntary 545-day call-ups to compel inactive officers from the Individual Ready Reserve (IRR) to leave civilian life for duty in Iraq. Over the last few years, the Army has ordered hundreds of officers from the IRR to report to U.S. bases to prepare for Iraq deployments. This is considered by many officers as an unfair “backdoor” draft that only targets the officers the US Army is able to reach. Former Army Secretary Francis J. Harvey was quoted on the effort to find the officers in the IRR: "We don't know where the hell half of them are..." (Tyson 2006)

## Summary

In summation of the recommendations, the US Army should take a three-step approach to this pending crisis: (1) conduct an information campaign by targeting officers with 18+ years in the US Army; (2) formalize HRC informal incentive programs by publicizing incentive programs and control the selection of officers for these programs with one centralized section; and (3) offer a monetary bonus by giving cash incentives (bonus/matching TSP) to every officer serving past 20 years of service or target the officers serving in branches that are the most critical (enlisted model).

Based on the survey conducted for this thesis, a monetary bonus appears to be the best overall method to promptly address this serious officer shortage issue but will take time to implement. Although a financial incentive will not appeal to every officer, enough officers can be targeted to stay in past 20 years of service to avert a major crisis. Until the monetary bonus can be approved, other options can be used to target officers considering retirement at 20 years of service. This total approach initiative would mitigate and minimize the shortage of field grade officers until the appointments of new junior officers can work their way through the ranks and start filling the “air pocket” that is currently at the field grade level and avert a crisis.

APPENDIX A

SURVEY

Approval Letter

ATZL-SWA-QA

6 MAY 08

MEMORANDUM FOR: MAJ George Brown

SUBJECT: Request for Survey Research: "Major Crisis" Officer Retention.

1. Your request to administer a survey to US Army Active Duty Students attending CGSS classes 08-01 & 08-02 is:

**Approved**

Approved with Conditions (see below)

Denied (see below)

2. Your Survey Control Number (SCN) is **08-031**. This survey number must be clearly displayed on the front of your survey instrument's cover letter as illustrated below:

CGSC APPROVED SURVEY

SCN: 08-031

6 MAY 08

3. You are required to submit an *End of Project Data Collection Report* to the CGSC Quality Assurance Office when data collection for your project is complete. This report can be found at: [http://cgsc.leavenworth.army.mil/QAO/download/End\\_Of\\_Data\\_Collection\\_Report.doc](http://cgsc.leavenworth.army.mil/QAO/download/End_Of_Data_Collection_Report.doc).

4. Should you have questions concerning the above, please contact Mr. Rick Steele in the CGSC Quality Assurance Office, room 3524 Lewis & Clark, (913) 684-7331, DSN 552-7331.

**Notes:**

- This approves you to administer the survey only to US Army students in CGSS classes 08-01 and 08-02.

- You must make it clear in your survey invitation &/or cover letter that you are conducting research to fulfill your MMAS requirements and that your research is not being conducted by the US Army Command and General Staff College nor the US Army.

Ricky Steele  
CGSC QAO  
Survey & Research Control

## Survey

### **Are you a full time active duty US Army major?**

*{Choose one}*

- Yes
- No

### **What is your branch?**

*{Choose one}*

- Infantry
- Aviation
- Armor
- Engineer
- Military Police
- Chemical
- Field Artillery
- Air Defense Artillery
- Special Forces
- PSYOPS
- Civil Affairs
- Public Affairs
- Signal
- Military Intelligence
- Transportation
- Ordnance
- Quartermaster
- Logistician
- Adjutant General
- Human Resources
- Finance
- Comptroller
- Acquisition
- Medical Corps
- Dental Corps
- Veterinary Corps
- Nurse Corps
- Medical Specialist
- Medical Services
- Chaplain
- Judge Advocate General
- FA24
- FA34
- FA40
- FA47

- FA48
- FA49
- FA50
- FA52
- FA53
- FA57
- FA59
- OTHER

**What year group (YG) are you?**

*{Choose one}*

- 1988
- 1989
- 1990
- 1991
- 1992
- 1993
- 1994
- 1995
- 1996
- 1997
- 1998
- OTHER

**How many total years do you plan on staying in the Army?**

*{Choose one}*

- Less than 20 years
- 20 years
- 21 years
- 22 years
- 23 years
- 24 years
- 25 years
- More than 25 years

**How many total years of active federal service do you have?**

*{Choose one}*

- 8
- 9
- 10
- 11
- 12
- 13
- 14
- 15
- 16





## Survey Results

Raw data from the survey results is posted below in Table 3. .

Table 4. Raw Survey Data

	<b>Count</b>	<b>Percent</b>
<b>Are you a full time active duty US Army major?</b>		
Yes	412	96.04 %
No	17	3.96 %
<b>Total Responses</b>	<b>429</b>	<b>100.0%</b>
 <b>What is your branch?</b>		
(Not Answered)	17	3.96 %
Infantry	42	9.79 %
Aviation	33	7.69 %
Armor	26	6.06 %
Engineer	37	8.62 %
Military Police	12	2.80 %
Chemical	10	2.33 %
Field Artillery	33	7.69 %
Air Defense Artillery	13	3.03 %
Special Forces	12	2.80 %
PSYOPS	2	0.47 %
Civil Affairs	7	1.63 %
Public Affairs	1	0.23 %
Signal	25	5.83 %
Military Intelligence	28	6.53 %
Transportation	13	3.03 %
Ordnance	15	3.50 %
Quartermaster	15	3.50 %
Logistician	40	9.32 %
Adjutant General	11	2.56 %
Finance	3	0.70 %
Medical Corps	4	0.93 %
Medical Services	12	2.80 %
Chaplain	5	1.17 %
Judge Advocate General	7	1.63 %
FA50	1	0.23 %
FA57	3	0.70 %
FA59	1	0.23 %
OTHER	1	0.23 %
<b>Total Responses</b>	<b>429</b>	<b>100.0%</b>

<b>What year group (YG) are you?</b>	<b>Count</b>	<b>Percent</b>
(Not Answered)	20	4.66 %
1989	1	0.23 %
1990	3	0.70 %
1991	4	0.93 %
1992	11	2.56 %
1993	24	5.59 %
1994	72	16.78 %
1995	137	31.93 %
1996	110	25.64 %
1997	43	10.02 %
1998	3	0.70 %
OTHER	1	0.23 %
<b>Total Responses</b>	<b>429</b>	<b>100.0%</b>

<b>How many total years do you plan on staying in the Army?</b>		
(Not Answered)	18	4.20 %
Less than 20 years	4	0.93 %
20 years	250	58.28 %
21 years	17	3.96 %
22 years	37	8.62 %
23 years	17	3.96 %
24 years	20	4.66 %
25 years	24	5.59 %
More than 25 years	42	9.79 %
<b>Total Responses</b>	<b>429</b>	<b>100.0%</b>

<b>How many total years of active federal service do you have?</b>		
(Not Answered)	18	4.20 %
8	3	0.70 %
9	6	1.40 %
10	17	3.96 %
11	24	5.59 %
12	74	17.25 %
13	77	17.95 %
14	60	13.99 %
15	38	8.86 %
16	30	6.99 %
17	24	5.59 %
18	22	5.13 %
19	10	2.33 %
20	6	1.40 %
More than 20	18	4.20 %
Less then 8	2	0.47 %
<b>Total Responses</b>	<b>429</b>	<b>100.0%</b>

**Count      Percent**

**Are you prior active duty enlisted for more than one year?**

(Not Answered)	19	4.43 %
Yes	153	35.66 %
No	257	59.91 %
<b>Total Responses</b>	<b>429</b>	<b>100.0%</b>

**Are you married?**

(Not Answered)	18	4.20 %
Yes	350	81.59 %
No	61	14.22 %
<b>Total Responses</b>	<b>429</b>	<b>100.0%</b>

**Do you have children?**

(Not Answered)	17	3.96 %
Yes	326	75.99 %
No	86	20.05 %
<b>Total Responses</b>	<b>429</b>	<b>100.0%</b>

**How many unaccompanied deployments have you been on since September 11, 2001?**

(Not Answered)	18	4.20 %
0	40	9.32 %
1	160	37.30 %
2	135	31.47 %
3	51	11.89 %
4	17	3.96 %
5	4	0.93 %
6	2	0.47 %
More than 6	2	0.47 %
<b>Total Responses</b>	<b>429</b>	<b>100.0%</b>

**Count      Percent**

**What would entice you to stay in the Army longer than you currently plan to? (check one or more)**

(Not Answered)	20	2.58 %
One year base pay cash bonus for three years extra service	208	26.80 %
TSP Matching funds up to 10% per month	178	22.94 %
10% base pay bonus for command time	50	6.44 %
Guarantee non-deploying position (taken off command track)	56	7.22 %
One year college fund for every year past 20 for any degree level that may also be given to wife or children	124	15.98 %
Nothing	57	7.35 %
Other	83	10.70 %

**Total Responses      776      100.0%**

**What will be the reason for you leaving the US Army? (check one or more)**

(Not Answered)	18	1.51 %
Want to settle in one place	229	19.20 %
Disappointment with US Army leadership	75	6.29 %
Want a change in profession	96	8.05 %
Lack of military incentives	98	8.21 %
Daily OPTEMPO	96	8.05 %
Too many deployments	118	9.89 %
Civilian job opportunity	93	7.80 %
Lack of promotion opportunity	34	2.85 %
Family needs	229	19.20 %
I plan on staying in until my mandatory retirement	64	5.36 %
Other	43	3.60 %

**Total Responses      1193      100.0%**

Just over 60% (254) of the majors surveyed responded that they plan to get out of the service at 20 years or less. The following results are only the responses from these officers.

Table 5. Majors that Plan to Get Out of the Service at 20 Years or Less

	<b>Count</b>	<b>Percent</b>
<b>How many total years do you plan on staying in the Army?</b>		
Less than 20 years	4	1.57 %
20 years	250	98.43 %
<b>Total Responses</b>	<b>254</b>	<b>100.0%</b>

	<b>Count</b>	<b>Percent</b>
<b>Are you a full time active duty US Army major?</b>		
Yes	254	100.00 %
<b>Total Responses</b>	<b>254</b>	<b>100.0%</b>

**What is your branch?**

Infantry	27	10.63 %
Aviation	23	9.06 %
Armor	15	5.91 %
Engineer	23	9.06 %
Military Police	6	2.36 %
Chemical	5	1.97 %
Field Artillery	23	9.06 %
Air Defense Artillery	8	3.15 %
Special Forces	8	3.15 %
PSYOPS	1	0.39 %
Civil Affairs	5	1.97 %
Public Affairs	1	0.39 %
Signal	17	6.69 %
Military Intelligence	16	6.30 %
Transportation	11	4.33 %
Ordnance	9	3.54 %
Quartermaster	11	4.33 %
Logistician	24	9.45 %
Adjutant General	7	2.76 %
Finance	2	0.79 %
Medical Services	7	2.76 %
Chaplain	2	0.79 %
Judge Advocate General	2	0.79 %
FA57	1	0.39 %
<b>Total Responses</b>	<b>254</b>	<b>100.0%</b>

**What year group (YG) are you?**

(Not Answered)	1	0.39 %
1989	1	0.39 %
1991	2	0.79 %
1992	2	0.79 %
1993	10	3.94 %
1994	39	15.35 %
1995	101	39.76 %
1996	70	27.56 %
1997	24	9.45 %
1998	3	1.18 %
OTHER	1	0.39 %
<b>Total Responses</b>	<b>254</b>	<b>100.0%</b>

**How many total years of active federal service do you have?**

8	1	0.39 %
9	2	0.79 %
10	11	4.33 %
11	17	6.69 %
12	53	20.87 %
13	61	24.02 %
14	41	16.14 %

15	22	8.66 %
16	20	7.87 %
17	16	6.30 %
18	9	3.54 %
Less than 8	1	0.39 %
<b>Total Responses</b>	<b>254</b>	<b>100.0%</b>

**Are you prior active duty enlisted for more than one year?**

(Not Answered)	2	0.79 %
Yes	70	27.56 %
No	182	71.65 %
<b>Total Responses</b>	<b>254</b>	<b>100.0%</b>

**Are you married?**

(Not Answered)	1	0.39 %
Yes	215	84.65 %
No	38	14.96 %
<b>Total Responses</b>	<b>254</b>	<b>100.0%</b>

**Do you have children?**

Yes	195	76.77 %
No	59	23.23 %
<b>Total Responses</b>	<b>254</b>	<b>100.0%</b>

**How many unaccompanied deployments have you been on since September 11, 2001?**

(Not Answered)	1	0.39 %
0	30	11.81 %
1	94	37.01 %
2	80	31.50 %
3	34	13.39 %
4	8	3.15 %
5	3	1.18 %
6	2	0.79 %
More than 6	2	0.79 %
<b>Total Responses</b>	<b>254</b>	<b>100.0%</b>

**What would entice you to stay in the Army longer than you currently plan to? (check one or more)**

(Not Answered)	3	0.65 %
One year base pay cash bonus for three years extra service	124	26.84 %
TSP Matching funds up to 10% per month	104	22.51 %
10% base pay bonus for command time	28	6.06 %
Guarantee non-deploying position (taken off command	43	9.31 %

track)		
One year college fund for every year past 20 for any degree level that may also be given to wife or children	72	15.58 %
Nothing	36	7.79 %
Other	52	11.26 %
<b>Total Responses</b>	<b>462</b>	<b>100.0%</b>

**What will be the reason for you leaving the US Army? (check one or more)**

Want to settle in one place	151	19.09 %
Disappointment with US Army leadership	54	6.83 %
Want a change in profession	64	8.09 %
Lack of military incentives	72	9.10 %
Daily OPTEMPO	73	9.23 %
Too many deployments	85	10.75 %
Civilian job opportunity	64	8.09 %
Lack of promotion opportunity	20	2.53 %
Family needs	152	19.22 %
I plan on staying in until my mandatory retirement	29	3.67 %
Other	27	3.41 %
<b>Total Responses</b>	<b>791</b>	<b>100.0%</b>

The following results were extracted from the 17 non-respondents (4%) that did not answer yes to the question “are you a full time active duty US Army major?”

Table 6. Extracted Survey Results

		<b>Yes</b>	<b>No</b>
<b>Are you prior active duty enlisted for more than one year?</b>	Count	153	257
	Percent	37	63
<b>Are you married?</b>	Count	350	61
	Percent	85	15

<b>Do you have children?</b>	Count	326	86
	Percent	79	21

<b>What would entice you to stay in the Army longer than you currently plan to?</b>		<b>Yes</b>	<b>No</b>
One year base pay cash bonus for three years extra service	Count	208	204
	Percent	50	50
TSP Matching funds up to 10% per month	Count	178	234
	Percent	43	57
10% base pay bonus for command time	Count	50	362
	Percent	12	88
Guarantee non-deploying position (taken off command track)	Count	56	356
	Percent	14	86
One year college fund for every year past 20 for any degree level that may also be given to wife or children	Count	124	288
	Percent	30	70
Nothing	Count	57	355

	Percent	14	86
Other	Count	83	329
	Percent	20	80

**What will be the reason for you leaving the US Army?      Yes    No**

Want to settle in one place	Count	229	183
	Percent	56	44
Disappointment with US Army leadership	Count	75	337
	Percent	18	82
Want a change in profession	Count	96	316
	Percent	23	77
Lack of military incentives	Count	98	314
	Percent	24	76
Daily OPTEMPO	Count	96	316
	Percent	23	77
Too many deployments	Count	118	294

	Percent	29	71
Civilian job opportunity	Count	93	319
	Percent	23	77
Lack of promotion opportunity	Count	34	378
	Percent	8	92
Family needs	Count	229	183
	Percent	56	44
I plan on staying in until my mandatory retirement	Count	64	348
	Percent	16	84
Other	Count	43	369
	Percent	10	90

The following is a comparison of answers from those who responded that they plan to leave the US Army in 21 years or less vs. those who plan to stay in for more than 21 years (using the Kruskal-Wallis test)

The Kruskal-Wallis one-way analysis of variance by ranks is a non-parametric method for testing equality of population medians among groups.

The test statistic is given by:

$$K = (N - 1) \frac{\sum_{i=1}^g n_i (\bar{r}_i - \bar{r})^2}{\sum_{i=1}^g \sum_{j=1}^{n_i} (r_{ij} - \bar{r})^2}$$

$n_i$  is the number of observations in group  $i$

$r_{ij}$  is the rank (among all observations) of observation  $j$  from group  $i$

$N$  is the total number of observations across all groups

$$\bar{r}_i = \frac{\sum_{j=1}^{n_i} r_{ij}}{n_i},$$

$\bar{r} = (N + 1)/2$  is the average of all the  $r_{ij}$ .

Only the answers with statistical differences are posted below. The lower mean number indicates the higher likelihood of a “yes” answer and the greater the differences in the two “mean” numbers indicate a higher confidence level.

Table 7. Comparison of Survey Answers

<b>Anticipated years of service</b>	<b>21 Years or Fewer</b>	<b>More than 21</b>
Count	271	141
Percent	66	34

<b>What would entice you to stay in the Army longer than you currently plan to?</b>	<b>Years</b>	<b>Mean Rank</b>
Guarantee non-deploying position (taken off	21 Years or Fewer	198.77

command track)

More than 21 221.35

**What would entice you to stay in the Army longer than you currently plan to?**

**Years Yes % No %**

Guarantee non-deploying position (taken off command track) 21 Years or Fewer 17 83

More than 21 Years 6 94

**What will be the reason for you leaving the US Army?**

**Years Mean Rank**

Want to settle in one place 21 Years or Fewer 197.10

More than 21 224.57

Want a change in profession 21 Years or Fewer 200.53

More than 21 217.98

Lack of military incentives 21 Years or Fewer 196.21

More than 21 226.28

Daily OPTEMPO 21 Years or Fewer 195.97

More than 21 226.74

Too many deployments 21 Years or Fewer 194.81

More than 21 228.98

Family needs	21 Years or Fewer	199.38
	More than 21	220.19
I plan on staying in until my mandatory retirement	21 Years or Fewer	216.46
	More than 21	187.37

<b>What will be the reason for you leaving the US Army?</b>	<b>Years</b>	<b>Yes %</b>	<b>No %</b>
Want to settle in one place	21 Years or Fewer	60	40
	More than 21 Years	47	53
Want a change in profession	21 Years or Fewer	26	74
	More than 21 Years	18	82
Lack of military incentives	21 Years or Fewer	29	71
	More than 21 Years	14	86
Daily OPTEMPO	21 Years or Fewer	28	72
	More than 21 Years	13	87
Too many deployments	21 Years or Fewer	34	66
	More than 21 Years	18	82

Family needs	21 Years or Fewer	59	41
	More than 21 Years	49	51
I plan on staying in until my mandatory retirement	21 Years or Fewer	11	89
	More than 21 Years	25	75

## APPENDIX B

### SURVEY COMMENTS

Optional comments from the US Army active duty majors that took the survey

*\*All comments are listed here in anonymous random order without prejudice or spelling/grammar corrections.*

There also many job opportunities in the civilian sector that will pay you for your services or skill set the same or more than what you would receive as a LTC so why not retire and make that money in addition to the retirement pay. We did our time and served our country during difficult times and maybe its just time to take care of our families.

Army gives lip service to taking care of soldiers in a lot of areas. The housing and having to pay full BAH rate for these absolute ghettos here at Leavenworth is a prime example. Now they want to charge us for utilities on top of this! General Casey made a point of mentioning privatized housing as a good thing for the Army while he was here, but it is only good for corporate Army, not the soldier. Additionally, the inequity of Officer Bonuses is absurd.

The Army should consider allowing officers to transfer from the Army to the ARNG and back without loss of status, promotion timelines etc...This will allow mid career officers to satisfy family and/or educational needs for a short period of time before returning to the Active Duty Force.

Interesting survey - I have thought about this often. I see a need for an intentive at the 20 year point regardless of rank (04-05). Perhaps a choice of options from which to choose from.

Best of luck on your paper.

Love the Army, but want to pursue career in Homeland Security. If the Army is willing to allow me to work at U.S. Army North for an indefinite period of time, I would most likely stay in longer than anticipated. our senior leadership is out of touch. This began with the promotion of LTs to CPT at 34 to 36 months, etc. We now have MAJs with 9 yrs service. What is the point in taking away experience time from officers? I am not getting the logic to these "streamlined" promotions nor am I understanding the senior leadership's vision. Never saw a problem with a LT doing a CPTs job, etc when the promotion system becomes invalid and we have the No CPT/MAJOR/LTC/COL left behind program it sullies the rank.

As I mentioned on the last page, I am more than likely going to stay in until 24-26 years, with or without the incentives. Nevertheless, the incentives are nice and those listed on

the previous page are good ones. Considering increased costs in living and inflation, the government should more aggressively increase pay and BAH IOT maintain pace with economical costs; and also to fund college for our children. Increasing compensation equal to or better than inflation, college funding for children, ensuring no cuts to retirement benefits, as well as ensuring no medical costs are passed to soldiers & families through Tricare will help long term retention.

At this point in our careers, I think those of us who have decided to stay on have not done it for immediate incentives. The retirement package is a great long term benefit, but I think at this point it's about how we and our families feel about what we are doing. I don't think short term incentives will change people's minds about staying past 20 years

Should have included disappointment with the National Command Authority as an optional reason for leaving the military.

You might want to consider the unique challenges of retaining dual military couples who have twice as many family separations as those where only one spouse is in the service. Also, on your question that asks if giving college benefits to family members would entice longer service, recommend changing 'wife' to 'spouse'. Just my 2 politically correct cents.

No issues

Pay is low compared to the time and energy given, no bonuses or other incentives for FG, no wonder CPTs get out, who wants to be an Iron Major?

We move too much.  
Quarters can be disgusting.  
Health care hasn't been good.

My branch makes me change from specialty to specialty so that you never get good at any one.

The Army leadership protects too many people these days. There are too many of my peers that are not pulling their share of deployment opportunities, yet will be looked at in the same light when it comes time to promotion potential and command screening. The current system does not benefit the guy that works hard and contributes every day. At this level it is way too political.

If I stay past 20 years I am significantly reducing my potential to secure a high paying job when I leave the Army outside of the defense industry. In order to offset this loss, a 10% matching of TSP contributions would go along way to making up the extra retirement income. A cash bonus at the 15-17 year mark would help officers deal with family pressures that may cause an officer to leave early.

The attached expectation would be that an officer serve at least 20 years.

Great research...I believe this is a necessary and viable study.

Recommend taking a look at the recent survey results of senior officers (active and retired) on the state of the Army. Believe it was sponsored by MOAA and/or AUSA. Press coverage maybe 2-3 months ago.

The Army is behind the curve again.

Too bad, a lot of good people will leave due to lack of simple incentives.

One of the greatest disappointments when I came in the Army was the College Student Loan repayment program being cancelled. I don't understand .....we serve the nation....go to war (several times) and yet we can't have a program that states that if you serve 20 years Honorably...the Federal Government will repay your student loan or basically cancel your debt because you have "more than paid it back" !!?? That would be a great incentive to keep officers in!

At this point in my career only a serious family issue or moral crisis would cause me to leave the service before 20 years.

Currently my faith in the service, satisfaction with assignments, compensation and benefits is sufficient to motivate me to remain until my 20-24 yr mark.

incentives for captains are nice, but we need some incentive for majors to stay in the Army. The conventional wisdom that we are bought into the corporation at the 10 year mark is being pushed aside as we continue long deployments and difficult staff jobs working for senior leaders who are out of touch.

The need to be "KD" before getting promoted is discouraging. It interferes with alternative tracks that are very positive for the army. An example would be MITT teams, FAO, or Liaison officer in foreign countries.

If there was an abundance of MAJs or LTCs, there would be a RIF and there would be minor payments made for our dedication and service. Since the opposite is true, there should be a real bonus to compensate us for our continued service. It is hard on the body at my age to keep up with the Soldiers and hard on the family to deal with deployments for a year plus time. Offer my family a place they want to be for 3+ years and a nice bonus, and I would be interested in staying in longer.

I like the Army & want to stay in. I think the leadership needs to step up and be a bit more definitive about the future and do something to fix it. It's getting old listening to the same excuse-we're growing the Army..have been for 7 years-still no solution. We are transforming...have been for 7+ years enough already. When my family reaches the break

point I will leave-that break point is continual deployments...so far I haven't hit it -yet.

I love the Army, but I do fear that working long hours will destroy my marriage. I really hope that the Army considers this and works on a real balance for all soldiers in the military.

Retention of MAJs??? By this point we are tenured in our careers and the Army doesn't have to offer us anything to retain us. Most MAJs are going to go for "20" and get the lottery ticket for life.

As a field grade officer (including time as a commander) I have had subordinates (with equal or less time in service) that got paid more than me. I'm not in for the money, but it does upset me when my subordinates get paid more than me.

I would like to see the Army give tuition assistance for all schooling. Ex. working on a second masters degree, or just wanting to take colleges courses to better myself.

I don't understand why the army keeps offering officers ACS and not assist officers to pursue additional education on our own time. I would think it would save the army money.

I would also recommend having assignment of choice with U.S. Government Agencies. The problem is not one of FG retention. The problem is that we have created an enormous demand for FG officers by quintupling the number of FGs at the BCT level while simultaneously further INCREASING the FG requirements on a DIV staff. It now takes one LTC and 2 MAJs to do what one MAJ used to do, i.e. run a BDE S3 shop---and the BDEs are smaller now! How absurd is that?

The largest factor in my choice will be either my children (family) stability or command/post command assignments (war college). My oldest child will be 16 and in high school at my 20 year mark. Based on current timelines I will have commanded or be exiting command and heading to the AWC. I would have to choose my career or pulling my son out through at least 3 high schools.

I would appreciate seeing your write up when it is complete.

I have 10 more years and given the current OPTEMPO I feel that the next 10 years will be the hardest yet and not sure if my physical and mental capacity will remain as strong as it is now.

We seem like the Army "owns" us because we are near retirement and therefore the brass doesn't think we deserve or need a bonus to stay in longer. Give a bonus with a service obligation attached! Also, why should I pushing myself for a "hard" KD job when I really don't want to be a BN CDR. A LTC yes, but a BN CDR...why? So that I can get deployed, have less family time, and all for the same pay as a staff LTC. I think all

command positions should get a 10% raise while in command.

Although I love the Army, there are several factors that will weigh on my mind. Deployments, physical wear and tear on my body, and a desire for more family time will probably cause my retirement at 20 years, but it will be the most difficult decision I'll have made.

The Army has active duty MAJ and above for the most part by the short hairs. MAJ are high demand and becoming low density, but there are absolutely no incentives to keep us in, because "they" know we are over the hump. It is ashamed that the only reason the Army gives incentives is to keep people from leaving early, not because they being constantly deployed, work long hours and see thier family very little, those are the reasons why soldiers should be offered inentives.

I always thought that I would stay in the Army for 28-30 years, but from a family, financial and professional standpoint I believe it is in the best interest of my family to retire after 20 or 21 years of AFS. Some of the incentives proposed by this survey could definitely change my perception of what is in my best interests.

Brother-

Sure that some of our peers are closer to retirement- but that is too far away over my horizon to determine reasons / timing for retirement. Unless I hit the lottery, that might change my perspective. But at the 12 year mark, it's too soon to say. Best of luck.

Staying in isn't worth the headache anymore. The personnel shortages and the constant expectations of doing more with less is crap. I can do that in the civilian world and get paid for it. The problem is the strategic level of planning and our inability to get folks in the Army. It took five years to get a surge in Iraq and six years to admit the military was too small and we had "to grow the Army".

Are you prior AD ENL >1yr? WO service?

-Didn't enlist for \$(selfless srvc) but O4/17yrs pay good

-Deploy OK, it's Army(loyalty)& part of job(duty)

Context:am lift AVN/O4/solid marriage so easy for me to say

-Effects of early '90s involuntary seps comming back? Army loyalty to OFF then?

-No field grade incentives; Army assumes stay in till 20, incentive to stay past 20?

-O5s say no to CMD; incentives to accept BN CMD challenges?

O4 to O5 & retirement w/out putting up w/ aggravation.

Settling down is my primary reason for getting out. Other reasons include the incremental piling on of tasks when we've generally acknowledged we can't do all we have as it is.

I do not plan to leave the Army until the Army tells me to leave. That said, I recognize that the Army strains my family at least as much, if not more, than me. I will leave the Army if my family asks me to, even if that is before 20 years.

We don't do it for the Money. But, the hardships our families go thru need to be compensated for to retain quantity and quality. I don't think I would stay in if I didn't have 16 yrs invested.

I only speak for myself, I'm here because of service to the country. Deployments are going to happen and are not going away between now and retirement (or anytime soon) but decision to retire or leave short of retirement will be for selfish reason such as putting family first. There are many ways to serve our country and military service is only one of many other ways to serve our country and allow us time with our families.

The piece time Army was a very busy organization with most soldiers working close to 12-hour days; since the war began it has only gotten worse. The other day I overheard a Navy officer chastising an Army officer for leaving his family for a year at a time, "what kind of father and husband would do that to his family", he said. The war on terror is a very busy time indeed.

With three children in school, stability for my family is the top priority. I really don't have a problem with the OPTEMPO - because really, it's what we signed up for. but I do have a problem with having to move my family around every two years as a field grade officer.

Although incentives would be welcome, my family's willingness to move will be the deciding factor on staying to MRD. I am not sure I am willing to move my daughter during her high school years.

I hate the Army. I stay because if I live to a normal projected life of 80 years I will (depending on the cost of living allowance raises) make about 2 million dollars in retirement. I simply want to stay until I get a pension- No civilian job can match that and any Army officer who thinks they make more on the outside is sadly mistaken (because they do not figure in the lost pension. Medical and dental HMO costs alone undermine this argument.

Your question about unaccompanied deployments does not make sense. All deployments are unaccompanied.

Pay and allowances or bonuses (while they would be nice to have) are not an incentive for me to remain in the Army at this point. There are a lot of challenges to the job in the current environment but ultimately, it is what I signed up for 18 years ago at the beginning of ROTC. If promoted to O6 I would consider remaining beyond 22 years, but that is not a promise. Family needs at the time will dictate the direction we head.

I don't mind the moves or even occasional deployments. But I have gotten tired of always having to take "needs of the Army" positions and never being able to take a "good" assignment. For me I would like to do a ROTC PMS assignment, if it appears I might get

it I will stay in otherwise I will probably get out.

Would like to see military family members eligible for in-state college tuition in any state as an incentive to keep senior officers/NCOs on active duty past 20 years. At that point, lots of officers/NCOs make the decision to get out in order to stabilize the family in one state. For a family with 3 kids, the difference between in-state and out-of state tuitions is easily >\$100K.

I have enjoyed my career, but it is time to focus on my family.

My deployments counts 3 one year tours in Korea and 1 one year tour in Afghanistan. All were unaccompanied.

I love the Army. It takes great care of me and my family but eventually the costs outweigh the benefits...right about at the 20 year mark.

The TSP matching falls into the "it would be nice" category, but money alone would probably not change my decision to stay or leave the Army.

The Army is expecting persistent conflict on the backs of the few. Not sustainable in families, morale, and effectiveness in the face of new threats. Command/promotion opportunities are greatly diminished for the engineer branch due to transformation and modularity. These are not the opportunities promised at the start of our careers for good work and skill. The menu of incentives is a slap in the face. Give to all, or dont give at all.

We are overlooked for incentives and bonuses b/c the old Army adage that "once they are Majors, we've got'em for life!" HQDA doesn't realize the void to be left when current Majors leave the military at 20 yrs.

The Army will again be forced into early promotions and bonuses for the cohort with the current table of incentives. They won't be seasoned, prepared, nor ready to accept the responsibilities of a higher rank, leaving a "hollow" Army at a more senior level of command!

I think the unpaid sabbatical is a good idea that I have heard kicked around quite a bit. My spouse, for example, is almost done with a PhD, but needs to spend a year in Massachusetts collecting data. We have moved all over for my career. It would be nice to be able to take a year off from the Army in order to support my spouse's career aspirations.

The Army is a tremendous institution and I have no regrets joining. However, there comes a certain point in most individuals lives in the Army when their family has sacrificed enough and they must become the first priority. I love the Army but I love my family more. FYI, I am AGR

It seems we're the forgotten rank.....I just wonder how many in our year group will be around after 20

Overall, honored to serve in Army til 20 year retirement or few years beyond.

I tried to leave meaningful comment but the 500 character limit prevented it. If you want meaningful input allow more than that.

It is personally and professionally disrespectful to offer \$35,000 retention bonuses to CPT's a couple years behind me and not offer anything to me. That tells me that the Army doesn't want to retain me.

I have enjoyed my time in the Army and live day to day with the intention that, when it isn't fun any more I will quit. I am routinely offered 3 times my Army salary to work for civilian contractors but I enjoy the honor of the profession and the soldiers I work with.

I do not appreciate the army mentality that, since I have stayed in for over 10 years that the Army has me "locked in." The Army should start considering the needs of mid grade MAJORS as well.

Embarrassed to say that no deployments would keep me in past 20. But I really want to start a family (hard to do that deployed) and I want to be around my kids as they grow up.

I plan to stay in the Army for 20 yrs AD and 4 yrs RSV (college). I may stay an additional two years in order to take the promotion to LTC (if selected). Depends on my future family situation. Dating another AD Major and thinking to start a family in the near future.

I am a dual military Army wife. My husband and I decided that I would retire at 20 years service so I could be a stay at home Mom for a few years with our children while they were still fairly young (they will be 10 and 9 when I retire) and my husband will stay in the Army.

As checked earlier - would be nice to have a program to invest in education programs for either spouses or children and have an alternate program for those Soldiers without children or a spouse.

Gob Bless the USA!!!

I am considering leaving the Army before 20 years of service, even though it does not make economic sense. Reasons: poor leadership, too many deployments, too much time away from family, desire to settle down in one place for more than 2 years.

I really don't see any incentives to stay past 20 years. There is a modest increase in your

retirement pay, but not much else. Barracks conditions have recently become an issue and it won't be long before regular housing is too. Privatized housing has not solved the problem. Why should I as a Major be paying twice as much as a SPC for the same house. Rather than having those with hire rank subsidize lower rank housing, just set a rent price and let the Soldier choose.

I am an Title 32 AGR Officer

I don't understand asking this of Majors. Most Majors have been in over 10 years and have hit the "point of no return." Not all but most will stay at least for 20 years.

My children deserve the best college opportunities for their sacrifices. Its not about me, its about them. If the Army can help me afford a Tier 1 University for them, I will stay in forever, otherwise at a certain point I need to get out and get a job that will help me afford the \$30-50K annual tuition (projected) per child for a Tier 1 university.

Nominative assignment process for duty, schools, and training is currently unfair. HRC branches scrub files and select candidates based on their personal knowledge and opinions. They are not posting these nominative openings to see who is really interested.

An increasing "More with less" & "everything is a priority" approach/methodology is not conducive to the long-term effectiveness/health of our services. There is some truth in a saying that U.S Soliders undertake/endure a 20 year sprint to retirement. Thus, at 20 yrs, unless selected for advancement or command, in compromise for their decades of sacrifice/support, the family's vote will carry significantly more weight in any equation to continue uniformed service.

I enjoy serving in the military and I appreciate any support the military offers families in terms of housing, job opportunities, financial and college incentives that would enable my family to feel part of the military team.

I am undecided, but will likely stay until 20 based on recent career developments. However, I have been given a "carrot" that will keep me in until 19, thus makes no sense to not complete 20. However, had this, my current opportunity not been presented I would likely have got out at eleven years.

At the point where I realize I can actually do something to fix leadership problems in the Army, or at least make a positive impact. The frustrations of the early years have given way to a desire to make things right.

Not too many incentives to keep me in, money is almost an insult to the profession. That said, if the Army made any move on my 20 year retirement benefits I'd be ready to fight!

We need a BONUS -Sooner rather than later.

Personnaly, it is not the money associated with any of the bonuses that is important to me. It is the message that is sent with the financial incentives (or lack of them). The current lack of any incentive for majors sends the message that the army does not really care about and appreciate majors and LTCs.

I've been fortunate enough to be in good work environments for the most part. I don't mind deployments, the way I look at it is that the reason for the army's existence is to take care of things in foreign countries. I just look at that as part of my job. Allow room for more comments.

I have spent the bulk of the past 5 years away from my family. If the 12 on 12 off from deployments continue, along with most of the 12 month off time spent training for the deployment, it is likely I will not stay past 20 years.

I plan to stay in the Army until I retire. I do not plan to have another career after retirement. The TSP matching funds and command incentives are appealing to me.

The Army OPTEMPO will force me to choose my family over the Army. I've always believed, "The Army will not always be there for you, but your family will."

## APPENDIX C

### EMAIL FROM THE ARMY CAREER AND ALUMNI PROGRAM (ACAP)

You are receiving this message based upon information contained in your official records. If you have questions concerning this information, please consult your military personnel office.

Now that you have attained 18 years of military service, you may be considering whether to retire within the next 2 years or stay in longer. You are certain to have some questions about what your next career move should be. You may already be speaking to your retention NCO (NA for officers), your supervisor, fellow soldiers, friends, a spouse or a family member.

The army has a program to help you understand/realize what your options are and how to compare those options. The key to planning your future is this: the more information you have, the better your decision will be. You and your immediate family are eligible to use the army career and alumni program (ACAP) now!

ACAP is there for you. Whether you have already decided to separate from the military or are undecided, take advantage of the program to help you decide. To locate the ACAP center nearest you log on to [www.acap.army.mil](http://www.acap.army.mil).

ACAP centers offer a wide variety of transition services and job assistance training to include:

- Preseparation briefings (including completing the DD Form 2648, preseparation counseling checklist), where you learn about your entitlements as well as types of services and benefits available to you.
- Identifying military skills and experience and how they translate to private sector occupations.
- Preparing competitive resumes to work toward a successful career change.
- Training on effective interview strategies and identifying and researching job opportunities.
- Access to automated tools to help you compare current benefits and salary to comparable civilian compensation packages, should you decide to separate.

ACAP also schedules/coordinates the department of labor transition assistance program workshops, veterans administration benefits briefings, disabled transition assistance

program briefings and other specialized seminars pertaining to transition.

The ACAP on-line web site provides transition and job search information for separating soldiers and allows employers who are interested in hiring veterans the opportunity to post their job vacancies. The web site also lists job fairs and special hiring events.

The ACAP experience has been compared to private industry transition services costing \$5,000 - you can receive these services free!

## APPENDIX D

### MAJOR CRISIS ARTICLE IN THE *WASHINGTON POST*

## **Deployments Are a Factor in Army's Deficit of Majors**

Service's Plan for Growth Also Contributes to a Gap That Could Take Five Years to Close

By Ann Scott Tyson  
Washington Post Staff Writer  
Sunday, August 17, 2008; A04

The Army's growth plans and the demands of the wars in Iraq and Afghanistan are contributing to a shortfall of thousands of majors, critical mid-level officers whose ranks are not expected to be replenished for five years, according to Army data and a recent officers survey.

Majors plan and direct day-to-day military operations for Army battalions, the units primarily responsible for waging the counterinsurgencies in Iraq and Afghanistan. Throughout the Army, majors fill key roles as senior staff members, putting together war plans, managing personnel and coordinating logistics.

The gap in majors represents about half of the Army's current shortage of more than 4,000 officers, and officials say there are no easy solutions to the deficit. "We need more officers, and we are pulling every lever we can," said Col. Paul Aswell, chief of the Army's personnel division for officers.

The Army's plan to expand its ranks by 65,000 active-duty soldiers by 2012 -- to a total active-duty force of 547,000 -- is increasing the service's demand for captains and majors. The Army is currently about 15 percent short of its goal of 15,700 majors, and the gap is expected to surpass 20 percent in 2012, according to Army data.

The shortfall is forcing the Army to promote captains more quickly to the rank of major, even though the service is also about 10 percent short of captains. While the Army projects that it will fill the captain shortage by 2011, it will continue to have a deficit of majors until 2013, according to Aswell.

Some majors predict that the gap could widen because of repeated deployments to Iraq and Afghanistan. Those missions, some of which have lasted more than a year, are leading many of them to plan to retire from the Army.

"A lot of my retirement plan hinges on the deployment cycle and the war on terror as it exists today," said Maj. James Blanton, an infantry officer who returned in 2007 from a 15-month deployment to Iraq.

The Army says its data do not currently show majors or other officers leaving the force at accelerated rates. "Our loss rates are fairly stable, and the growth is what's killing us," Aswell said, referring to the Army expansion effort, first announced in January 2007.

But a recent survey of more than 400 majors at the Army's Command and General Staff College at Fort Leavenworth, Kan., indicates that could change in coming years.

"There is a tipping point that we have started to reach," said Maj. George B. Brown III, who conducted the survey and has discussed the problem with Army officials. "There is a much larger percentage of officers . . . planning to get out right at 20 years, and once they are gone, they are gone," said Brown, a graduate student at the college.

"We are overworked because of the shortages and have nothing to look forward to but another rotation to Afghanistan or Iraq, so everything weighs towards getting out," Brown said, adding that upon retiring in their early 40s after 20 years in the Army, majors receive half their base pay and can begin civilian careers. "It's almost like a perfect storm."

Other majors said the shortage means they are continually pulled into war-fighting jobs and have less opportunity to attend schools required for promotion or to take jobs that expand their horizons.

"As I look to the future, I see the choices I am offered narrowing and the freedom of decision I had start to go away because of the shortages," said Maj. Kim Nash, a transportation officer. "I was originally scheduled to get my master's and go teach, and that was derailed by deployments; that window is gone for me now."

Brown's research found that nearly half of the specialty branches are so lacking in majors, they would be considered not ready for combat under Army reporting requirements. The shortage of majors is more pronounced in some branches than others, with a shortfall of 24 percent in military police and 27 percent among military intelligence officers. The Army's transportation branch has the greatest shortage, fielding less than 50 percent of the majors it requires.

Brown's study shows that the percentage of majors leaving the service increased from 3.75 percent in 1998 to 6.48 percent in 2007. "The exodus is expected to continue as more officers are leaving sooner because of the strain multiple deployments are having on families," Brown concluded.

The Army agreed that the rate rose through 2006 but said it fell in 2007 and remains within historic norms. Army personnel officials also challenged some of Brown's survey methodology. Even so, an Army critique provided to The Washington Post acknowledged that the survey "may provide some insights into current sentiment" among the classes that Brown sampled at Leavenworth.

The survey of majors found that more than half of those responding cited family needs, the desire to settle in one place and numerous wartime deployments as reasons to leave the Army. It also suggested that monetary incentives could be effective in persuading more majors to stay longer. But Army officials said that such a program, while considered in 2007, is not an option because it would be prohibitively expensive.

Instead, the Army's strategy is to shore up the ranks of captains, offering \$35,000 bonuses and other unprecedented incentives in a program launched last year. That program so far has led nearly 14,000 captains -- about 1,000 fewer than the Army's goal -- to sign contracts to stay three years longer.

Yet Brig. Gen. Michael S. Linnington, commandant of cadets at West Point, said groups of Army captains recently returned from Iraq have told him that long deployments -- not bonuses -- are central to their decisions. "The whole Army is pretty tired," he said.

Because of the shortage of majors, the promotion of captains is now nearly guaranteed: Well over 90 percent have been selected for promotion to major in recent years, compared with the Army's goal of 80 percent.

"The Army would prefer to promote officers at a lower rate to encourage high performance," Aswell said.

This month, results are expected from the first Army promotion board since the Vietnam War era to reach into the ranks of captains and promote the most qualified candidates two years earlier than the norm.

In addition, the Army is assigning captains to serve in jobs normally performed by majors, and in some cases, majors who have been promoted to lieutenant colonel must stay in their current jobs longer, Aswell said.

**COMMENTS** *(posted from newest comment to oldest with not grammer/spelling corrections):*

Green\_Pig wrote:  
TO: ArmyGI

Incredibly well explained and very true.

8/18/2008 4:37:36 PM

ArmyGI wrote:  
To have a viable volunteer force we need to make the necessary \$\$ investment in our mid-career managers.

It's common for experts and surveys to say it's not about the money. For the military member, it's often not. But if pay is not adequate compensation, it DOES become about the pay. We overlook what we are 'compensating for.' Bottom line: staying in or getting out is a family decision, with the Active Duty member often saying if it were just me I would stay in. So how does it look at the family/spouse level where these decisions are ultimately made?

Brilliant number crunchers argue that pay is comparable to similar civilian jobs. Ohhhh?

1) Try to get those comparably paid mid-career managers to separate regularly from family going into harm's way and then see what you have to pay them.

2) Also overlooked in the compensation calculations is a total family focus. The military members pay should be at least 1.5 times 'comparable jobs' on this basis alone. Why? To compensate for the spouse's lost income potential. These officers marry bright, competent, career-capable partners. But when you're doing frequent military moves and effectively single-parenting, it's next to impossible to also have a viable career. It may not be about the \$\$, but these spouses are comparing their family lives to brothers, sisters, friends from college, etc. Comparisons are inevitable (cars, houses/quality of neighborhood schools, etc). If the compensation doesn't keep pace at a family level (and it doesn't), that, along with stresses of military service, carry the day in the 'stay-in' or 'get-out' decision.

8/18/2008 3:50:42 PM

hayes2 wrote:

Can't wait to see the projected shortfall now that Mr. Bush/Cheney/McCain and lobbyist friends have committed in their "Peace Keeping Humanitarian aid" to Georgia.

Can we spell DRAFT?

RUN! Colleges no matter how expensive will be full, if the exemption holds..the exemption our great leaders including Mr. Clinton used to get out of thier fighting experience in the name of 'freedom' against those dirty Russians that never came!

8/18/2008 10:16:33 AM

bfjackjernigan wrote:

In the early 1950s through the late 70s the Strategic Air Command (SAC) destroyed the married lives of bomber and tanker pilots as well as their enlisted crews through sorties without end or explanation to families at the height of the "cold war". The result was what we called the "TDY widow" who eventually could no longer stand the extended, unexplained separations. The result was a huge and continuing divorce rate among SAC crews.

Now add in the guard and reserve deployed in "the war on terror" and the number of

broken marriages grows even further as O-4s (Major and Navy Lt. Cmdr) are critical personnel and all members of that rank, active and reserve, have had enough of endless family separation and eventual civilian job loss upon their return.

Major or Lt. Cmdr, (O4) means military career life or death. Obviously there are those who have had enough would rather end their careers, active, reserve or guard than lose their families.

We either increase our officer corps, with fair rotations and compensation (as we should our senior enlisted), or we must face a reduction in force that can be blamed upon nothing other than this administration and its policies.

8/18/2008 3:52:47 AM

mchaun wrote:

The Officer Corps should implement an Equal Opportunity Program for Democrats. Any Liberal who has witnessed the way you slimy cowards treated them would have to be nuts to serve.

There are more Contractors over there than troops, why not Draft those KBuck/day baby shooters?

Not much of a military anyhow- a bunch of Dead-Enders led by Officers devoid of Gallantry, Courage or Chivalry with the highest collateral and friendly fire damage in history. Torturers and Queens of the sniper and air strikes, phosphorus, cluster bombs and thieves to boot.

If your "enemies" were one-tenth as well armed, you'd be crawling back to Twenty Nine Palms and North Carolina crying for your Mamas.

If the stories of Iraq and Afghanistan are ever told the Nation will never forgive you.

Monte Haun mchaun@hotmail.com

8/18/2008 1:01:50 AM

Green\_Pig wrote:

But you cannot draft someone for 10+ years... the draft is only to quickly build up the lower ranks - the issue is the incentive to maintain these Soldiers and Officers over the years and not lose the best from the military to higher paying civilian jobs; jobs that do not include deployments for 1-year+ every other year.

8/18/2008 12:26:18 AM

DinoD wrote:

This article accurately highlights the ramifications of fighting extended conflicts with an all volunteer force (AVF). Debates over the political decisions that lead us into the current multi-front war (Iraq, Afghanistan, and everywhere else) are moot. Barring a miraculous, instantaneous eruption of world peace, at some point another President would have had the need to deploy the AVF into an extended conflict; it's all we've got. So, we are seeing the impact that any such extended effort – now, or in the future – has on the Army and Marine Corps.

I am confident we will continue to attract enough young men and women to enlist in the armed forces because the recruiting machine is finely honed to appeal to the myriad reasons a young person chooses to enlist. As the article highlights, the real long-term impact of this extended fight is being seen in the mid-grade officer ranks. The loss of these young, talented officers is what is “breaking” the Army, and to a lesser extent, the Marine Corps. One can always buy more stuff, but the experience (yes, time-in-service matters) and education (both experiential and continuing professional education) required to make a major or lieutenant colonel cannot be easily replaced. It takes about 10 years to produce a major and about 15-16 to make a lieutenant colonel.

The real question for our country is whether the AVF is really the best way to provide for the “common defense” as called for in our Constitution. The Army and Marine Corps are growing under the assumption that we need more personnel assets in order to employ them in future low-intensity and counter-insurgency conflicts. Would we be better served if we challenged this strategic assumption? The low-intensity conflicts that everyone refers to when justifying an increased force structure will be wars of choice, not of necessity. Where is the critical analysis that by restructuring our force so that it is optimized for nation-building and then employing it to that same end, a positive outcome with respect to US interests is probable?

8/18/2008 12:16:39 AM

mchaun wrote:

I think I know where they went-promoted to Light Colonels. Iraq seems to be swarming with them, teaching the Iraqis all about Democracy. They are usually in full battle dress, wearing shades, preferably Jewish and standing 1 inch from the Tribal Chief yelling in English. And they all seem to have the same Given Names. Google "Lt Col Jeffrey" 38,000 hits, "Lt Col David" 90,000 hit.

Maybe we are over-officered- they have an Admiral leading the Guantanamo Marines who have to smear the prisoners own excrement and urine over them if the prisoners refuse to do it themselves.

8/17/2008 11:56:43 PM

rcc\_2000 wrote:

jimmyz211,

You have some serious anger issues. You're better off sticking with Fox News or you will certainly pop a blood vessel.

Fact is that Bush went to war looking, supposedly, for WMD's. Cheney assured us he knew where they were and about how we would be received with open arms. Instead we got a mess, the war planning was poor at best and they had no plan for after "shock and awe". No one is blaming our brave soldiers we are blaming the idiots who put them in harms way without thinking it through. Bush is a traitor. Oh and I am happy to be "YOU PEOPLE". BTW there are more of us people. Based on your venom, anger and hate I can see why you admire GW.

8/17/2008 11:02:11 PM

WestTexan2008 wrote:

OldCoot1,

It is urban myth that the military is made up of poor kids seeking an education. I worked personnel - 83% of enlistees come from middle class families.

8/17/2008 10:15:35 PM

Schweg wrote:

Perhaps the Majors all finally found the time to obey their CIC and go shopping (for a better job)!

The DOD can call this number 1.800.210.0060, Monday - Thursday 8:30am - 8:00pm and Fridays until 5:30pm. Ask for the career placement office. It's the number for Regent University.

8/17/2008 10:05:19 PM

OldCoot1 wrote:

Isn't it time to bring back the draft and get a broader section of people in the military? As it is all that enlist are poor kids that want to get an education that they can't afford. I think that every person should be drafted for two years when they turn 18 years old or graduate from 12th grade, high school. The kids would get more of an education in the military then they would in the first two years of college and the high and mighty wouldn't be so quick to start wars if their kids were in the military and might have to fight. If your country isn't worth fighting for maybe you should leave.

8/17/2008 10:05:19 PM

WestTexan2008 wrote:

Mid-grade officer retention is much more complex than this article lets on. There is only one bottom line - the individual officer has to make a decision as to what is best for country, family and career. The military, like all large corporations, attempts to foresee as many of these issues and make policy to manage the numbers. They can offer pay changes, bonuses, volunteer or mandatory severance packages and training perks. They also manage deployment cycles, arduous duty assignments and overseas duty. They have to manage this within a budget environment that changes yearly and by election. They never get it perfect and they never will - there are simply too many variables. Sometimes they are short Majors (in my day it was senior Captains); some days they have too many; ironically, sometimes both. At one point I was offered a large sum of money to stay; I took it. Four years later, I was offered an even bigger pot of money to leave (I declined because I could not remain in the Reserves if I took this option).

Add to this, the pressure that the corporate marketplace adds by putting a premium on officer experience, and it is little wonder that the mid-grade officer career field is difficult to manage. For the most part, officers show up on time, plan ahead, stay late, follow directions, don't do drugs, and willingly learn what they don't know in order to do the job better. Most workers do not.

8/17/2008 10:03:23 PM

Green\_Pig wrote:

There are two different issues here - the war on terrorism (a must fight/win situation) and a military in a shortage of officers because the military is at war, but our nation is not.

8/17/2008 10:01:54 PM

UE\_Graduate wrote:

Draft the tax evaders and corporate criminals first.

8/17/2008 9:55:46 PM

jimmyz211 wrote:

Just why do you tink they put in negative article about our military and our country? To sell papers to liberal buyers.

Even a fool can read between the lines in such news items. This isn't even news. It's BS!

They think that with president milquetoast that the whole world will sing Kum Bay ya and wine and honey will flow. No, the world is a very dnageroud place wh very dageir oud peop that you can't deal with. You must destroy them or they will destroy you.

What do these idiot liberals think Saddam Hussein would have done by now? The problem was getting worse every year for a decade. 17 UN resolutions violated, US and coalition planes being shot at. Oil for food money being stolen. UN mandates and UN

resolution 1441. Corruption with Saddam and Russia, France Germany and the head of the United Nations Somone please tell me what war was perfect. What war had no mistakes. I wanna know

This is political and Democrats are using this war to win an election. The war on terror is no joke. Radical Islam is no joke. It's REAL.

Yah, Rumsfeld and Bremer were wrong. Now the surge has worked. Armchair quarterbacking is real easy.

Liberals just sit back and complain, but they never have any real answers. NEVER!

A party of weak, pathetic whiners and defeatists.

Tell me, who hates America. They take our aid and money don't they. When Islam takes over weak Europe and China starts a war over oil with us and Russia teams up with Iran to attack us, then it's over.

8/17/2008 9:54:48 PM

VApolitics wrote:

One last point Jimmyz211 -

Your heroes are not conservative. Conservatives don't start wars to spread democracy or run up big deficits where we have to borrow money from China. Even Pat Buchanan has said this foreign policy was silly.

8/17/2008 9:53:44 PM

AresBelt wrote:

Even in the face of major cracks in the dam.....the denial that anything is wrong continues.

Either the ranks are being depleted at an accelerated rate or DoD management has done a lousy job of planning. You can't say the attrition rate is normal when you're faced with significant shortfalls.....

8/17/2008 9:52:35 PM

UE\_Graduate wrote:

Explore Dual Citizenship.

Serve the Queen by joining the Royal Air Force.

Or even the Canadian Mounties.  
8/17/2008 9:50:39 PM

VApolitics wrote:  
Have your opinion Jimmy.

After serving over 7 years on active duty and 5 in the reserves I'm not a radical, but if it walks like a duck and quacks like a duck I am going to call it duck. While Secretary Gates is doing a good job, the majority of time during President Bush's two terms this Defense department has done alot of waddling and quacking. It has not been pretty.  
8/17/2008 9:47:12 PM

jimmyz211 wrote:  
Whne they put something negative about the military and it draws these rabid foaming at the mouth radical liberal lunatics like moths to a flame. Most of these loser wouldn't join up and serve our country if their lives depended on it. They are self loathing whining, miserable excuses for human beings, or as I call them "LIBERALS". Wahhh.

Osama bin Laden would be happy to capture them and kill these liberal whiners and then cut of their tiny heads.

Let the rest of the world know that these liberal cry babies don't represent America. They represent the European defeatists and appeasers.

To read these 'rag' newspapers it's no wonder the socialist and radical Muslim jihadist think they an defeat us. Moms and Dad's should know that the big bucks that they're spending for their kids is being used to teach this garbage to them by their liberal professors.  
8/17/2008 9:34:22 PM

VApolitics wrote:  
Jimmyz211,

There was nothing in this article that directly said the GOP, the President or even Rumsfeld screwed up. Of course it is not hard to take the next logical step. Bottomline, this is a real problem, it doesn't matter if you are on the right or the left. If we listen to people like you and ignore it, the problem will not just go away.

Lastly, if people want to blame on those civilian officials who headed the Pentagon for the first 6 years of the administration they should. The only one of those guys who ever served was Rumsfeld. He was a Navy fighter pilot for one tour and I doubt he had much

command experience. Wolfowitz and the others never served a day in uniform and wouldn't listen to the Generals who said this ain't going to be easy. Anybody can screw up if they are arrogant - doesn't matter if they are conservative or liberal!

8/17/2008 9:30:22 PM

jimmyz211 wrote:

I'd like to tell the liberal newspapers why their readership is down. We are sick and tired of you putting down the military and our country for your warped liberal political views. Dry up and die.

Why don't you cover the rape of Georgia by your socialist pals and the radical Muslim terrorists that blow up innocent people and our brave American soldiers because of their warped, distorted religious views?

I've had it with YOU people. That's right! YOU PEOPLE!

8/17/2008 9:20:32 PM

jimmyz211 wrote:

Will this liberal nonsense of not having enough troops because of Iraq ever end? If I ever heard the liberal media tell one positive story about our military or our country I would pass out.

I'm so sick and tired of them all.

Ten year Navy vet

Gee, I know, if the liberal media had Obama as president there wouldn't be any need for majors because there'd be no more wars or human conflict of any kind. Oh brother.

8/17/2008 9:14:10 PM

VApolitics wrote:

Draft not Likely - - Some of the early posters must have some draft phobia or conspiracy assumptions that drive their thinking because the history of the Army makes a draft highly unlikely.

First, the current Generals were junior officers during Vietnam and remember the draft. The draft gave the Army drug, criminal and discipline problems. Time and resources had to be diverted from everyday tasks to deal with these problems. Moreover, the Army learned a conscript Army does not fight effectively.

Second, a draft would not solve the current shortfall of Majors. Majors are not created overnight. To become a Major you first must earn an undergraduate degree, serve at least

one initial tour in your specialty, go to career level professional school that may be a year or so, and serve another assignment with a unit or on a staff. This may take about 10 years in normal times. No a draft won't solve this.

I also disagree with the people who say the lack of Majors is not a problem. Yes other people can step into the jobs that Majors do. However, if you have an individual that has put in the time to become a Major, that person brings along judgment. Sure a Captain can probably do the same job, but hasn't faced the same amount diverse experiences a Major may have in his or her career.

A SNCO may have had abroad range of experience, but a crucial element is missing. That SNCO has rarely been in the formal chain of command - meaning if things went wrong typically it is some officer that is ultimately responsible not the SNCO. Doesn't mean that the SNCO would not face punitive consequences, but you think differently when the orders are transmitted to you, you execute them and are held responsible for their failure on a daily basis. You learn to balance a wide variety of interests. I know when I was in command I would get alot of ideas, some sensible and some not from those who did not have to answer to my boss.

Additionally, as a Major you can work with other Majors more easily. I was on active duty in the Marines and we had something you call the Lieutenant's Protective Association. That doesn't disappear when you advance in rank. It is also great to be able to pick up the phone call your peer in another command when you need more information than is being passed or will be late on a deadline.

Lastly, the lack of Majors means that the pool to select Lt Colonels from is smaller. Meaning you may see a fall off in quality at that rank in the future.

8/17/2008 9:07:25 PM

Walkerbert wrote:

One remedy that's been mentioned to address military shortfalls has been 'the draft'. The letter in the mail, join the army, or go to jail. In theory, there's tens of millions of potential servicemembers, and all Congress would have to do is reinstate the draft and suddenly the recruiting stations would be chock-full of people. And, with Canada now on board to turn back deserters, today's Army could end up being quite large in the not-so-distant future. Just some paperwork to get through, initial here, sign here, initial here here and here, now, hold up your right hand, and repeat after me, I, state your name(no, state YOUR name....).

8/17/2008 8:11:47 PM

kackermann wrote:

Before going into Iraq I was very sceptical of the motive. Cheney miscalculated when he tried to tie Iraq to 9/11. He should have just stuck with the threat thing because he labeled himself a liar right away. But...

We were told there would be minimal resistance and there would be flowers and candy waiting for us. So as long as the civilian population was essentially safe, I figured that getting in, removing Saddam, and getting out fast could be good.

I didn't believe for a minute there would be a democracy there because it fundamentally flies in the face of Sharia law - or I should say that it allows for too many contradictions.

Does any of this sound pragmatic so far? Do I seem like a nut? Would it be unreasonable for an officer to think something similar?

They of course are expected to support their mission in full, but it would be unreasonable to expect them to leave their brains behind.

A conflict is created when on the one hand you want officers with sharp brains, but then you stick them in missions whose goals begin to conflict with American values and appear to be strategically unwise.

How many were let go because they could not suppress their ability to reason sufficiently for some ideology up the chain of command.

We saw some of it play out in public, and for the record, Sinsheki was correct.  
8/17/2008 8:08:46 PM

nonneocon wrote:

Well Jenna Bush's husband should be ready to enlist, that will make one less Officer needed to join.

8/17/2008 7:52:44 PM

kackermann wrote:

After reading yesterday's article in the Post about having local and state police gather intelligence on Americans even if they are not suspected of a crime, means that there is not much reason anymore to join the military.

It's not like we would be fighting for our country, we would be fighting against our country and supporting what is becoming a totalitarian state.

FISA not only eroded out civil liberties, but it let criminals off the hook and made accountability impossible.

As far as I'm concerned, this new ability to spy on any American is the point of no return.

People are going to naturally capitulate because we are a nation of sheep now, but the capitulation is going to signal massive abuse by the government just as it always does

100% of the time.

It is going to raise the chances of abusive incidents, and it will prompt emotion-driven events where normal citizens take exception over something and lash out in such a way that they will find themselves in jail.

There are going to be people in jail essentially for "subversive" actions.

You don't join the military in a nation like that. What you do is start talking to any soldier you know right now and ask them to promise never to aim their gun at another American.  
8/17/2008 7:40:27 PM

donnolo wrote:

15,700 seems like an awful lot of majors for an army of half a million. Assuming that there are twice as many captains and four times as many lieutenants -- after all, not everyone gets promoted -- that means that there are more than one-fourth as many officers as privates.

I wonder what the corresponding ratio is in the Russian and Chinese armies.  
8/17/2008 7:37:46 PM

Immanurse wrote:

Five years+ of your life for your country to me is enough! I have read all the posts on here and many are from the military. This is from a MOTHER two tours Iraq, one to follow this fall and my question, what is the difference between the DRAFT and what the military calls STOP LOSS??? Show me the difference!!

Show me the difference between Iraq and Afghanistan? Biting the bullet in Iraq is no different than Afghanistan, dead is dead!

8/17/2008 7:33:25 PM

Green\_Pig wrote:

Ref the retirement program changing: the 20-year retirement program may already be changing... A panel looking at military compensation has recommended payments to military retirees would begin age 57 (not the day you retire) for those with 20 years of service or more and at age 60 for those with less than 20 years of service.

8/17/2008 7:11:47 PM

Simon23p wrote:

Clearly, if Obama wins all his Berkeley supporters are going to sign right up.

8/17/2008 7:03:53 PM

justjunkemail wrote:

Poor leadership, poor planning, outright lies by the chump in chief, and now they want to reduce retirement benefits and raise tricare payments.

What do you expect, kids running to the recruiting office?

Nobody wants to serve a \*Cough\* leader or a country that only mouths empty words and promises to take care of them.

8/17/2008 6:49:58 PM

camera\_eye\_11 wrote:

n2avalon wrote:

I think the all volunteer army can not sustain us in time of war. There for I submit that the next time some Idiot wants to take us to war he better have a national draft authorization in his or her back pocket long before the war starts.

Do it now!!!

~~~~~

If you add "no deferrals" to that no matter who your parents are along with "war zone infantry duty for all new recruits", then there will be no "war a la Bush" because the snotty kids of the wealthy will have to serve; and I mean REALLY serve.

Obama '08.

8/17/2008 6:29:58 PM

gadlaw wrote:

It's happening in the Air Force as well. I do not know of any Majors eligible for retirement who are staying in. Constant deployments, lack of opportunity to advance and inability to take care of career development as mentioned in the article as well as poor leadership in higher ranks. These never ending wars after the Vultures took their 'Peace Dividend' by closing bases and cutting personnel where the best people left the service and you have this continuing crisis that will only get worse. It will only get worse.

8/17/2008 6:27:55 PM

John991 wrote:

Maybe it's time we ask what we're doing in Iraq and Afghanistan. From what I can tell, we're spending billions and accomplishing little. The troops get up every morning and go out and drive around in circles, waiting to get blown up. And yet once we pull out, it'll be like we were never there a few months later. Like Vietnam.

Maybe someone should take a look at Europe and the new Russian menace. Poland and the Ukraine?

Where are the Neocon geniuses now?  
8/17/2008 6:05:09 PM

Green\_Pig wrote:

The survey that Major Brown conducted indicated that 60% of those officers who came in the Army in the early to mid-90s plan to retire at just 20-years of service or less... This is a major knowledge/experience drain on our military. Nothing is being done to encourage these officers to stay in, yet the shortage of these officers is already over 15% and growing. Some specialty branches are already manned under 50%; when do we hit the breaking point?  
8/17/2008 5:54:26 PM

coldbay wrote:

We can thank our "Commander In Chief" for this mess. It wont improve with the next "Commander In Chief". With the Congress working for the special interests.What do you expect.  
8/17/2008 5:46:51 PM

rcc\_2000 wrote:

It seems to be SNAFU. The military, make that the Bush Military, is disorganized and refuse to see the world as it is. Instead of addressing the issue they seem to be hiding their heads in the sand. Thanks to George Bush our Military has gone from "shock and awe" to shock and awful. Bush is a traitor. He has helped Osama, Putin, Chavez and the rest of the worlds despots become stronger and more aggressive because he decided to tie up our military on his misguided vendetta against Saddam.  
8/17/2008 4:49:50 PM

n2avalon wrote:

I think the all volunteer army can not sustain us in time of war. There for I submit that the next time some Idiot wants to take us to war he better have a national draft authorization in his or her back pocket long before the war starts.

Do it now!!!

promises and laws will be broken but hey what's new. Washington is so wrapped up in their own little club and getting re-elected they are in fear and denial but can send our mules to war util they fall under the burden. Our army is the mule.

8/17/2008 2:40:19 PM

edfeeney wrote:  
I consider this a "major" problem.  
8/17/2008 12:46:43 PM

Apostrophe wrote:  
Last officer remaining gets to be the new Chief of Staff...  
8/17/2008 12:40:42 PM

Pearl77 wrote:  
Simple solution: drag all the chest-thumping neocon chickenhawks out of their country clubs and send them over. Never has more tough talk been made by so few who have actually served, starting with the Chicken-in-Chief, Dick Cheney. This mess lies right at the feet of republicans.  
8/17/2008 12:29:53 PM

809212876 wrote:

...  
chambers14 wrote: "It would have been reasonable for this article to mention that the current shortage of field grade officers also links back to the shortage of junior officers in the mid-to-late 1990s. These are basically the same people we are talking about. Then, it was the Clinton DoD and the dot.com economy. Now it's war, and deployment fatigue because our Army isn't large enough to spread the workload. . . . "

I worked 30 years for the Army in the DC area, at MACOM HQs and HQDA. I recall the officer drain of the mid 1990's. Some of those younger officers who left did NOT have faith in their superiors, many of whom they viewed as opportunistic ticket punchers who'd say or do anything to get ahead. Some of them left for the significant bonus money, salaries and perks paid by corporate firms during the dot-com go-go years.

Our military was cut too much, starting with G.H.W.Bush who was cutting the Army at the same time we were loading the ships for Desert Storm. Soon after that war, papa Bush mustered much of our victorious forces out of the Army. I recall the stories in the WaPo about these guys looking for jobs during the slow economy of late-term Bush-41 and early Clinton. The GOP Contract With America and Bill Clinton kept cutting the Army as an aid to balance the budget during the years of battling over that issue. No doubt some savings from cutting the Army was used to pay the cost of tax loopholes for vested interests.

8/17/2008 12:28:21 PM

tagazio wrote:

It amazes me...in the mid 1990s we had too many captains and majors. So many in fact that we had reduction in force boards and paid people to leave the Army.

Now we don't have enough and are paying officers to stay in. We really need some forward thinking planners so our Army can get out of this knee jerk reaction everytime the pendulum swings the other way.

If we hadn't cut everything so deep in the 90s, would we be facing this issue today?  
8/17/2008 12:24:58 PM

JERRYB1 wrote:  
What a disaster, thank you Cheney and Rumsfeld.  
8/17/2008 12:00:38 PM

DDilegge wrote:  
Zendrell,'

What planet do you reside on? Your comment here is - how should I say? - BS.

Dave  
8/17/2008 11:50:42 AM

KarenLS wrote:  
That's their story and they are stickin` to it no matter what out of fear that if they acknowledge it the problem will worsen. As it might. People who see others making that decision might be on the cusp anyway and see the exodus as validation of their own feelings and beliefs. I would say they worsen it by not acknowledging it but quite frankly there is nothing the Army can do to fix it. It is all up to the politicians...oh, and the Iraqis to see if they kick us out. That won't fix it as the troops will just be moved next door to Afghanistan but at least there is only one fight going on then and not two.  
8/17/2008 10:22:31 AM

bernardreilly wrote:  
As a dad of a West Point grad class of 2001 who left the Army after a year in Iraq, year in Afghanistan, and facing another deployment, I looked for but did not see officer retention rates I am quite certain West Point class of 2001 well over 50% resignation rate, far in excess of historical.  
8/17/2008 8:12:03 AM

georgekrivsky wrote:

Draft all the neocons, there is enough of them; they knew well before the war started, how to lead us to the victory.

It were to be short and painless operation!

8/17/2008 6:43:32 AM

blackjack3 wrote:

Another reason for the resignation rate of O4/MAJ's is the fact like most of us..the war in Iraq is of such a political dimension that few can continue to support multiple tours. Sure, perhaps one time..but, two or three rotations to include Afghanistan.

The news today..what do we hear of Iraq? Not that much..the Sadr Army said they would disband if US moves to the 16 months or definitive time table for withdrawal. This is the political dimension..among many others.

Normally, majors are selected at 10th or 11th year of active service; getting out is essentially throwing away those 10 or 11 years, so the impact of the decision is monumental..

We wish them well.

LTC US Army

Iraq/2005;Afgh/2003

8/17/2008 5:03:16 AM

TheodoreRoosevelt wrote:

Deployments Are a Factor in Army's Deficit of Majors

////////////////////////////////////

Not just Majors, everyone. Troops are becoming disillusioned due to the totally directionless politics of Bush.

No one will fight a police action that has no end nor purpose no matter how patriotic.

The mission was Usama, and leave, and Usama wasn't in Iraq. Now 6 plus years later Usama is still free. Al Qaeda and the Taliban have been allowed to grow, for the most part unbothered, while Afghanistan has been the forgotten war.

We have wasted troops and wealth in the Hundreds of Billions, if not into the Trillion, and with everything else added just about bankrupting the nation, and still no Usama, and no strategy exit or otherwise

8/17/2008 4:24:32 AM

chambers14 wrote:

It would have been reasonable for this article to mention that the current shortage of field grade officers also links back to the shortage of junior officers in the mid-to-late 1990s. These are basically the same people we are talking about. Then, it was the Clinton DoD and the dot.com economy. Now it's war, and deployment fatigue because our Army isn't large enough to spread the workload.

In the 1990s, following the breakup of the Soviet Union (and the first Iraq War), we stood down Army divisions and Navy/USAF air units, mothballed old ships (and built fewer new ones), and concentrated our forces onto fewer bases. Net results = smaller (though arguably more capable) forces, but thinner personnel pipelines, and more sensitivity to attrition through the ranks.

In one sense, we chose disarmament -- at least in terms of reducing our force size. Unfortunately the world didn't return the favor by getting any less dangerous for us or our allies.

8/17/2008 1:55:21 AM

mill wrote:

This has happened before. I as an LT and later a Captain in the 70's we were required to step up to the job and fill positions there weren't majors for--without the benefit of early promotion. What the military found out (not that it had a choice) was that some jobs it was having majors do should have been filled by more junior officers, some should have been filled by warrants and NCOs and some should have just gone away--which they did for a time. Interestingly when the military gets "fat" with people "new" positions pop up for people to fill. This isn't a story worth a great deal of interest. Yes, it would be nice to have more majors but things won't "go bad" if the Army doesn't have the total number it's thinks in currently needs.

8/17/2008 1:15:55 AM

zendrell wrote:

Oh wah....let's face it, the O corps is not all that it is cracked up to be, this is not a 3rd world country. Though they are viable, a good warrent officer or SNCO would do quite nicely. Then again, this is nothing but a result of all those personnel drawdowns to pay for the expensive toys.

8/17/2008 12:18:28 AM

## APPENDIX E

### BATTLE COMMAND KNOWLEDGE CENTER (XO/S3 NET) COMMENTS

The following are comments from the Battle Command Knowledge Center XO/S3 net in response to this thesis. All the comments are presumed to be from US Army majors because access to the site is controlled. The comments are posted with no grammar/spelling corrections. The author's name has been deleted.

September 15, 2008 1:43 AM.

XXX writes: I put in my retirement packet this year. I'm a MAJ with 20 years and will turn down 0-5 to retire. XXX comments mirror my own. Even though I have 20 years, branch continues to treat majors as though we must bow down to the needs of the Army for every assignment, while offering captains the world to stay in. I've done my time in 2 combat zones and am now choosing to put family first. Bottom line is that I'm voting with my feet.

Saturday, September 13, 2008 1:50 PM.

XXX writes: I am a YG93 officer that was enlisted for 3 years prior to going green to gold. I know first hand the long hours and mental strain of always serving in units understrength in certain career fields. I have silently done my job and sacrificed the time I should have spent with my wife and kids for the last 10 years only to be asked to do more.

The Army has overlooked our year groups and throwing money at it will not fix the issue, we need our branch managers to rotate officers to jobs or schools where they can reconnect with families and relax from the current pace of combat tours and the regeneration. The assignments page should be turned back on, not to allow you to sign up for a job but to allow officers to research what other jobs are out there so they can make a better informed decisions about staying to 20 or transitioning to the civilian job market. No one knows about the other possible jobs beyond KD jobs. What is my next potential job? Should I gut out 12 months to get my dream assignment? Right now no one knows... currently, 12 months at home station does not mean 12 months with your family. The timeline to get units back to MTOE strength does not line up with the training and equipping timeline which also strains the leadership. By time you look at gunnery, NTC/JRTC, PDSS, Bn FTX, Bde FTX, equipment reset, LBE draw/turn in managed by understrength staffs. It is just something to make the politicians and senior leaders think everything is going just fine.

If the situation does not change we will see even more officers turning down commands,

knowing that means one more deployment cycle. We need the information so we can sit down with our families, discuss the possible Army positions available and decide when it is best to move on. I would rather leave the Army when I want to as opposed to when the Army is done with me.

Good research, I will be interested in seeing what if anything is done to address the strain on our year groups.

RE: How do we keep Major's in the force?  
by XXX Yesterday 9:59 PM  
George,

There is little that I disagree with on your statements so far. I think you have some great points and appreciate the discussion you have generated.

In my posting, what I was trying to bring to light is one way that would reduce the foot print in theater. I think we can have a smaller foot print by creating a better policy for how employ units in theater. The key to shorter deployments is that they are without leave. Obviously emergency leave is required, however the amount of people moving between theater and homestation for leave requires a significantly more personnel supporting this and divides the unity of effort. If a unit deploys for 6-8 without the mid tour leave, I believe their focus will be better, they will do the job better and they will come home sooner without the additional number of bodies required to move this force in and out of theater daily. I don't know of any studies on how many people this could potentially reduce but I think that it would if someone looked into it.

Food for thought. In the end will it keep Maj's in the force longer? I don't know, it probably isn't enough relief to cause a largely significant change in optempo however it is only an idea at this point.

Thanks

Maj

RE: How do we keep Major's in the force?  
By XXXX on Today 4:11 PM

Here is another piece of information to chew on. Between 20-26 years of service you can expect on average to PCS between three to four times--taking into account you are selected for War college. So that is three or four times that your children have to change schools, make new friends, make the local sports teams again and the list can go on and on. While I do not have any number to support this, most of our children are hitting middle school or high school during this period which in my opinion makes it worse.

Additionally, what if your spouse is working...is it possible to maintain a job with that kind of pace? Absolutely not and I do not truly believe that any amount of money will solve this problem. The Army has to find a way to allow families to remain stable for a period of time (three-four years) in that 20-26 year window or unfortunately, I believe more and more that Officers and their Families are going to walk.

September 6, 2008 4:06 PM.

I would like to share my comments since I am one of those prior service officers who can actually retire even before LTC. I am also at ILE.

There are 4 main reasons that I am pondering retirement in the next 4 years at my exact 20 year mark:

1. After 20 years, when is the Army going to let me have the assignment I want at the duty location I want to have? I have spent the last 16 years going to where the Army has wanted me to go and have done the jobs my bosses have directed me to do. After 20 years, when do I get a decision for once? I joined the Army to see more of the world than Germany, Ft. Polk, and Ft. Hood with short stops at Forts McClellan, Leonard Wood, and now Leavenworth for schools. Let's also add 5 deployments (Panama, 2 x Balkans, and 2 x OIF).

2. Deployment equity. I've been twice and others have been 1 or none. Until everyone else catches up to me, I believe I should be low on the OML to go unless I choose a job or volunteer for a job that I know is going. If getting an S3/XO KD job means a deployment than that is different than a call out the blue from branch saying your on a MiTT or WIAS tasking. Also, if I have already been to OIF twice and I have to deploy, send to OEF or Horn of Africa, or someplace else. Thirty total months and I am burned out on Iraq right now.

3. Family. Even before my son was born, my wife and I made an agreement to stabilize him for high school. We agreed to drag him around the world from K-8, but 9-12 where the money is made for college and beyond, he needs stabilization especially being special needs and EFMP. The crap of 12 month unaccompanied is just that, crap. It is another unofficial deployment without the extra money. Put me at a location where there are a multitude of career progressive assignments for family stabilization.

4. Assignments. Not everyone needs to stay on the track for BDE Command. Some of us don't aspire to that and don't believe we should be forced on the narrow track to BDE Command. There are probably a multitude of jobs for field grade assignments that most officers will never know about because the information is never provided by branch and/or senior leaders on all the available positions. I believe I can be an asset to my

branch and the US Army for many more years without having to compete for BDE Command.

Bottom line is that after 20 years, family and personal preference and goals tip the balance away for the Army's need. A true equity in assignments and duty locations would go a long way to retain field grade officers.

September 3, 2008 7:24 AM.

A worthy topic for research and discussion; I applaud the effort. I did not have time to review the entire thesis, but I would offer some internal and external factors for your consideration: Are we crossing a generational divide that fundamentally changes the organization? Perhaps this is the RMA so many seek to define (and some to foster). I agree that personal economics play some role (and age, and the individual potential to earn not only money, but another profession and different, but greater satisfaction), but I think it would be interesting to compare macro high and low points to retention rates (i.e. the late 90's CPT's scare). The new GI Bill will also weight greatly on career decisions: Are we becoming too smart for our own good? Is there any research that points to senior NCO trends that mirror time in service? I subjectively offer that I see the same conditions in E7-9, as you ID'd in O4-5. Best of luck!

September 1, 2008 11:00 PM.

XXX, in the defense of the "slick sleeves" remember that there are those who have deployed to locations supporting RFFs that do not provide for a combat patch (e.g., humanitarian missions in Iraq, Cambodia (de-mining), Balkans, OEF-Phillipines, OEF-TS, Operation Noble Eagle, etc). After Desert Storm, I spent time in the Balkans (Bosnia mainly, but Croatia and Kosovo as well) and several GOs attempted unsuccessfully to get combat tour credit for those that went.

Granted, there are those who have never deployed and the effort by the CSA to get them downrange is an effort to provide better equity across the force. At the same time, I know several Majors who have the "slick sleeve" through no fault of their own. They have tried to deploy and were told no they were too important where they were. I felt that pain while in stationed in Germany when I tried to get deployed and was told no while seeing my wife off to OIF II (of course, the other CPTs and MAJs in the unit were deploying or already deployed leaving the unit absent alot of staff personnel, so someone has to stay behind and do the work).

If HRCOM would ever start actually looking at the ORBs (besides to screw them up by adding things mysteriously) to see who had been where, rather than Branch trying to take care of their "bodies to slots" mentality (and they can't say they aren't shifting meat around since they use a slide with hamburgers on a grill to denote places to go) or trying to "make good" with various commands.

Studies, hypothetical or not, provide valid information. Since many of the HRCOM studies don't get the response of the one that George did, no wonder HRCOM is trying to quote rules and regulations. Good on ya George!

RE: How do we keep Major's in the force?  
Tue, Aug 19, 2:16 PM

Interesting article. No surprise the big Army would have "issue" with the survey methodology. :-)

The missing caveat was that by sucking up Captains to be Majors early, the experience level issue arises (much like the "lets accelerate LTs to CPT in 36 months leaving the LTs no time to gain experience" deal of some years ago) as well as simply plopping Majors into LTC positions (but not promoting the Majors after there 4th or 5th positon normally filled by a LTC) since many branches don't have enough LTCs. More troops means more units means more field grades yet the "up or out" process continues and we lack more than just CPTs and MAJs.

Me, I prefer to stay in and affect things from the inside. I pass 22 years active Service next month, am a permanent Major in SELCON status, and am glad to remain to support the Soldiers to expedite staff efforts/work downrange since they are doing the real heavy lifting. It would be easy to get out, make a bunch of cash, and have no real job satisfaction rather than stay in until the Army kicks me out (yelling and screaming that I should stay in) at 24 years to do my small part to make a difference.

Wrapped in a flag? Ok, however, at the same time, I just don't want to have to wear a tie to work anytime soon! ;-) Kidding, but then SEMPER GUMBY!...rant off.

Former XO, 310th MI BN

RE: How do we keep Major's in the force?  
Thu, Aug 21, 4:06 PM

My opinion; It really boils down to control. Soldier's and their families are losing control of their ability to reach their goals, desires, aspirations, etc. in life due to increased demand for Solder's to be away from their family, their home, their way of life. The loss of officers is simply a symptom of this loss of control. Soldiers are being asked to put their personal and family goals aside while they take care of the military's goals and objectives.

At the end of the day, will a bonus fix the system? I am not sure. Soldiers get into this business because they like the adventure, challenge, and to be a part of the greater

cause. Bonuses work because they are a means to an end. They simply offer soldiers flexibility and allow them to control other aspects of their life that they wouldn't otherwise while they are serving in the military. It provides a method to achieve and do what isn't otherwise available.

RE: How do we keep Major's in the force?

Thu, Aug 21, 12:46 PM

Sir,

As a senior CPT waiting for the MFE AC MAJ promotion list to come out on the 26th I have a lot to add what it might take to keep me in now or past 20. I am a prior service enlisted SM and a Recall to Active Duty officer who left the Army back in the mid 90s as a 1LT(P). I came back on active duty in early 2002. I also took a CSRB for EN officers last fall for 25K. So with the promotion list coming out and me facing a PCS and likely TT Tour after being TCS/TDY for the last two years the importance of my family cannot be overstated. I have 10 years till I retire so my family has agreed to try and stick it out at least for now but HH6 has a lot to say. Beyond 20 it's not even on the radar. The Army really doesn't do much at all to keep CPT and MAJ in. The bonus in retrospect didn't amount to much that another tax free deployment wouldn't give you anyway. One of the biggest things is the constant PCS moves every 2-3 years. I have had my family in three states in 4 years. If the senior leaders of the Army can't figure out that might be an issue then God help us. My former roommate was promoted to MAJ in SEPT 07 and then REFRAD in MAY 08. His #1 issue was his family. Can I by staying in effect things? I seriously doubt it. I can't remember the last time a senior leader sat down and actually talked to CPT and MAJ about these issues. Lots of PA rhetoric and flag waving. The Army's system of assignments through HRC is so broken it's insane. So between complete and utter lack of predictability and myriads of PCS moves what CPT(P) or MAJ wouldn't punch out? Do I like the Army and the SM I work with yes but I love my family more. My one suggestion is go to some sort of six year life cycle unit manning for CPT(P)/MAJ. With the few major Army posts these days it shouldn't be an issue. That way Families don't have to move every one to two years. Just my two cents. Update 260900AUG08. No BZ for me despite holding every "KD" position for a Engineer Officer thru CPT and receiving top ratings every time. Not tooting my horn what that tells me is the boards could care less and what senior raters indicate don't amount to much. DA and HRC Promotions Branch squealed that the sky was falling and just had to add in another YG (01) to the FY08 eligibility. Well the promotion rates were the same as last year and no increase in BZ picks despite nearly all the CPTs these days having the experience of older ~YG 92-96 MAJs. BLUF the Army continues to promote solely on numbers and not performance. I know I was a old LT who still was rated on the ABOVE, COM and BELOW scale before the Army went soft and decided that every officer idiot or not should be promoted to CPT. That fact also frustrates CPT(P)/MAJ who stand witness to incompetent peers or lazy ineffective superiors. So just continuing to slog along. My CSRB ADSO is up when?

Thursday Last Week 7:57 PM

My three year old has been to 25 states. We have lived in three states in three years. I am writing this note from a trailer because the BCT complex is not yet ready for us. It will remain this way until after our next deployment. The on-post townhouse at my last assignment was demolished last week. The Army is changing but I encourage everyone to examine why they are serving and remain committed to this transformation. We have young leaders who need our guidance.

RE: How do we keep Major's in the force?

Wed, Aug 20, 5:31 PM

Nothing can be done? Crazy thoughts.

I believe a monetary bonus is in order. Just have the Army Leadership look at the sister services who provide their critical officer leadership with bonuses to remain, be retained, on Active Duty.

I know that Army Spouses are enticing their Major to leave AD service because they can "make more on the outside". The fact is with the downturn in the economy a bonus would ensure the nation's defense would be preserved in our investment in these Major's commitment to continue service beyond 20 years.

The MFE or Operations Career Field and select Logistics Career Field are in serious jeopardy, they need the bonus the most due to the churn of frequent/back-to-back deployments.

Thanks!

Former XO Aviation Bn

Former DPTMS

RE: How do we keep Major's in the force?

Tue, Aug 19, 8:03 PM

I prefer to stay in the Army to make a difference in our country every single day if at all possible. I do not serve for the money, and do not believe we need to demand a bonus. That would not really embody "Selfless Service" now would it? I believe "family needs" are a very big reason majors are getting out. I think being a major in the Army today does cause a large strain on that officer's family, and he or she has to make a concerted effort to maintain the balance between growing professional requirements and spending quality time with his or her family. This is not as easy as some might think. Regarding possible solutions to our shortage of majors, we can possibly close the gap (even if just a little) by looking at those majors that left the Army within the past few years, and see how satisfied they are with civilian life. It might come as a shock that some of them are not as satisfied as they thought they would be, and would like to return to military service once again. During my three years in USAREC, I interviewed several former Soldiers in various ranks who told me civilian life after Army life was not what

they expected. They explained how much they missed serving their country. We recruit for OCS candidates, WOFT candidates, etc, so we could look at future concerted efforts to recruit those qualified majors back into our ranks if possible, even if they only recently left the Army.

RE: How do we keep Major's in the force?

Thu, Aug 21, 3:10 PM

In a time when we are already short Majors, the Army needs to do something more to keep the existing Majors on active duty. Status Quo on Majors' attrition will only make the situation worse. Patriotism only carries you so far. Additional incentives are required, but can the Army afford it? What kind of incentives should be offered?

I consider myself a patriot, and will more than likely stay the course at least to a 20-year retirement, regardless of whether the Army introduces any additional incentives. However, patriotism only carries you so far. Adequate compensation for services rendered carries you the rest of the way. If you think you are still in the service just because you are a Patriot with a deep sense of duty, then think about this: Would you still stay in the Army as a Major if you were only receiving half of your current salary? Whether we admit it or not, most of us stay in as officers, because the pay also isn't half bad. However, being at war, deploying every second or third year, and compensating for the shortage of manpower by working even harder is burning out many officers. Salary status quo can only hurt officer retention.

Can the Army afford to give Majors a bonus or fund other incentives? Emphatically, Yes! The Army is getting a bargain right now. The Army is short approximately 15% of its authorized strength of Majors. That means that 15% of the budget set aside to pay Majors' salaries is not being used. In theory (and practice), 85 Majors are working harder to do the job of 100 Majors, and not getting any extra pay. That 15% of the salary could easily fund bonuses or other incentives for Majors who are working harder than ever. This might be an oversimplification, but premise is sound, and the money is there. I must admit to a certain amount of selfishness. What red-blooded American wouldn't want to be paid more for what they do, regardless of their Patriotic tendencies? However, my selfishness extends not only to getting paid more for the work I do, but also to avoiding having to work even harder. If we lose more Majors, then we collectively will have to work even harder to get the job done.

Possible incentives could include: bonuses, Master's degree programs, duty station of choice, and assignment in newly developing Inter-agency positions. All would of course incur some additional service obligation.

Thank you all for your service to our great nation. Regardless of your motivation, you are protecting our freedom.

v/r,

RE: How do we keep Major's in the force?

Thursday Last Week 1:38 PM

Interesting approach; however, if we're short 15% now, pulling Majors off to get their masters (unless its via 100% distance learning which I'm doing right now) and shifts to emerging jobs with inter-agency would only exacerbate the shortage issue.

Lets face it, Majors do alot of the heavy lifting staffwise. Simply throwing CPTs into the Field Grades faster is a disservice to the Army and those CPTs who already go from LT to CPT way too fast--no time to mature or hold the positions that provide experience to deal with increasingly complex issues which comes wiht the rank. Not saying they caqn't do it, and wartime Service accelerates the learning curve, however the staffing curve is steep already. I spent right about 9 years as a CPT (came in 2 weeks before the end of the FY as a 2LT so am forever a "Tail End Charlie" for promotion) before pinning on Major (at the 11 year mark) and the wealth of positions, issues, experienced people that I worked with gave me the training and insight I would not have otherwise gotten.

As for money, that might make our spouses feel good in the short-term, but the continued deployments and "do mor ewith even less" approach will only come right back. "Right-sizing" the force requires a thorough review of the requirement for Majors (and CPTs and LTCs). I've held at least 4 positions that required a LTC in the past 9 years via the USR "two up one down" rank approach. In one case, I held an O-6 position while the O-5 holding that position was gone for a full quarter--meaning I executed the duties of the O-6, the O-5, and my normal work all at once. So where does that fit into the OER that the boards don't completely read in the first place?

Retention should start at brass tacks.

1. How many Majors does the Army require? Figure that out first.
2. Truly fix the OER so it is useful (delete 80% of the front page nonsense which all boards ignore anyway and go to bullets on the back just like the NCOER-- promotion/school boards have no time to read the verbiage filled blocks for the R/SR anyway).
3. Fill positions with what they state as the required rank and eliminate the USR/SORTs "2 up, 1 down" rank nonsense. If you need a Major, send a Major. If there are none, review your requirement--simply filling a position with a Major because the requirement is "because a Major just left" is assinine.
4. Expand the Selective Continuation Clause (I'm a SELCON Major) after the 2d passover for promotion to maintain experience even if there is no hope of retirement. How many experienced Majors are lost because of the 2nd passover to LTC?
5. Allow retired/ETSed Majors to come back on to Active Service via a streamlined process rather than the current mountain of paperwork, "mother may I" requests that have to occur. If that is an HRCOM "to hard to do" whine, then bring the experience back via the Ralph Peters noted "Geezer brigade" (<http://www.afji.com/2007/07/2792594>) to free

up active Majors to go where they are needed.

6. Put a stake into the "up or out" promotion process for Field Grades and expand laterally to get the experience where its needed.

Remember, by 2010 nearly 50% of the DOD work force of Baby Boomers will be retiring. therefore, while the economy may be bad, the incentive to leave the Army is only going to increase as smart Majors move to fill positions in DOD left open.

Former XO, 310th MI BN

RE: How do we keep Major's in the force?

by [George Brown](#) on Thu, Aug 21, 7:59 PM

I hope you do not mind - but I think I'd like to use that "oversimplification" explanation of funding the bonus program in my thesis...

RE: How do we keep Major's in the force?

Fri, Aug 22, 9:57 AM

You are welcome to use it.

RE: How do we keep Major's in the force?

Thu, Aug 21, 10:27 AM

George,

I think you've addressed some very significant issues clearly and with good background data. I'd be interested in seeing your thesis, if you care to post it to this thread.

RE: How do we keep Major's in the force?

by [George Brown](#) on Thu, Aug 21, 2:06 PM

I will work w/ Mr Nelson to get the whole paper online. The thesis is still a draft, so I more than welcome any comments – both positive and negative.

George

RE: How do we keep Major's in the force?

by [George Brown](#) on Sat, Aug 23, 8:50 AM

After reviewing the survey results that were published in June 2006 by a spouse of a CGSC student for Central Michigan University, I discovered that the results of both surveys and the recommendations are incredibly similar. This replication of surveys validates what I think we all already know...

RE: How do we keep Major's in the force?

Friday Last Week 10:19 AM

I chose to stay in to this point in my career. As for bonuses, it would be very befitting to place a "career" bonus that is given to recognize our commitment to this organization. It has been done for enlisted soldiers since I joined in 1988. Now the enlistment bonuses are mind blowing for initial entry soldiers. But, there are no other corporations or entities that have this level of expertise and professional experience that the US Army possesses. If we want to stay the best, we should try to keep the best, we should make it more lucrative to stay. We do it for doctors and lawyers, why not all the others.

RE: How do we keep Major's in the force?

Friday Last Week 9:06 AM

One of the reasons the active force is overextended is the improper use of the Army Reserve. There are lots of officers in the Army Reserve that are mobilized but are not contributing (or are not being allowed to contribute) to the Army's mission downrange. The AC/RC unit I just left had a mission to train Guard and Reserve units for deployment, yet 1/2 of the officers and NCOs in the unit had not deployed themselves. They had very little credibility as a trainer. We need to re-look how we employ our USAR officers and better integrate them into the WIAS system. Many of them wanted to deploy, but they weren't being allowed to by the unit. Tour equity should work on both sides of the AC and RC spectrum.

RE: How do we keep Major's in the force?

Thursday Last Week 10:10 PM

I think the Army is trying to meet the challenge of retaining Major's in the Army in numerous ways.

First, the Army has decided to allow Officers to choice of Functional Areas or to remain in their current career fields. This has allowed us an opportunity to choose a different career path than the traditional path.

Second, the Army has offered several incentive packages to its Company Grade Officers for them to choose from. For YG's 99 and above the promotion rate to MAJ has increased to 98%.

Finally, I am not advocating that offering incentive packages to our Officers is the right solution or Army is doing all it can to retain its MAJ's and Families. I serve because I enjoy my profession and it's an honor for me to serve my nation. The majority of us will remain because this is our chosen way of life.

RE: How do we keep Major's in the force?

Thursday Last Week 9:37 PM

I have to agree with the theory alluded to by BG Linnington in the Washington Post, that we're just getting tired. I can't speak from experience about the extra long deployments or even multiple deployments; however the Army as a whole, even when you're not deployed, is working extra long hours. There are few opportunities to catch your breath. Families are home without one or in some case both parents. It is these situations which are causing people to opt out at 20.

Let's face it; if you have any economic sense as a Field Grade Officer you probably have a small fortune after multiple deployments and 20 years of service. Money isn't going to be the carrot that keeps people in long term. It might keep them in a couple extra years but it could also cause a culture change within the Officer Corps.

Easing the stress on multiple deployments and extended deployments is the key. One area that I would like to look at is the length in theater and the current leave policy. It takes a couple of staff officers to plan and manage the current leave policy for most units in theater. Let's shorten the deployment significantly and allow only emergency leave. This would ease the turbulence in theater of soldiers constantly coming and going and create units that are constantly coming and going for shorter periods of time. In my combat deployment, I was not afforded the opportunity for leave or pass; it was too long of a deployment at 12 months however, I think it is completely feasible for 6-8. Would deployment cycles be closer to each other? Yes they probably would but I think these would be easier to manage both organizationally and individually.

Great discussion, Thanks for the opportunity for input. Please provide comments to this divergent thought on solving the issue.

Maj

RE: How do we keep Major's in the force?

Friday Last Week 8:49 AM

I would argue we have already made that fundamental change in the Officer Corps with the offering of the retention bonus to CPTs. While many may not have voiced it, when the bonus came out there were probably more than a few who wondered to themselves, "hey, wait a minute..." It's simply human nature, but more to our credit, military nature that we kept our mouths shut over the issue.

But getting beyond the credo of duty honor country and selfless service, we have to look at the population most affected by this and ask if the policies in place now mesh with the idealization that I as an individual have worth and the ability to vote with my feet, as many of my peers have done. What do we have to change with our current system to bring about a realistic solution. As another poster said, patriotism only gets us so far.

RE: How do we keep Major's in the force?

Friday Last Week 11:17 AM

I think you are on to something with the shorter tours to support better retention rates. Face it, retention is a family decision. Optimally, our family support programs can thrive with service members deploying for about 9 months. After 9 months deployed, a lot breaks down and irrevocable issues can arise between military spouse expectations and the tiring Officer. Without bringing in all the constraints against this, a shorter tour would pay dividends to sustaining our Army for the long haul.

Dwell is often misunderstood as individual PERSTEMPO. On the contrary, dwell for rotational planning is only focused on the guidon timeline of boots-on-ground time and home-station time. For example, a unit that spent a year in OIF/OEF and returns home for a year prior to returning again is a 1:1 ratio of dwell. This dwell planning does not factor the individual PERSTEMPO of Majors or other key grades that rotate out of the unit returning and arrives just-in-time to conduct pre-deployment training for the next departing formation.

A 9-month tour and possibly allowing Major's to rotate on a shorter tours much like SPECOPS or other limited speciality skills can provide a sustained program targeted towards higher retention.

RE: How do we keep Major's in the force?

Friday Last Week 10:07 AM

George, you have hit the nail on the head. At the end of my latest deployment to Iraq for 15 Months I called HRC to find out what my options were for assignments. My branch manager stated that I could select from two division staff position that would deploy in 6 months, or select from several MiTT or PiTT positions. In complete shock I ask him if he realized that I was calling from Iraq and had three more months to serve prior to redeployment. To my amazement he stated that he realized this but the requirements for MAJ exceeded the number in the field. I had to fight to not be assigned to a unit deploying in the next 6 months. Luckily I won and am assigned to Garrison for a well needed breather for both me and my family. Apon assignment I was again shocked at the number of Majors I have run into that have never deployed to a combat zone. I don't know their stories but find it hard to believe that HRC has the full picture of the force.

RE: How do we keep Major's in the force?

Friday Last Week 12:36 PM

George,

I too am amazed at the amount of slick sleeves or a single-deployment, 6-week TDY combat patch for higher level HQ service in the IZ, Kuwait, Qatar or Kabul, among the

field grades of the Army. I saw a lot of both at USMA when I was up there in April for a Battle Command Conference.

RE: Major Crisis - How do we retain Majors?

Friday Last Week 12:27 PM

My old, across the street, neighbor and fellow First Team vet of OIF 06-08 has put the necessary academic foundation on a problem that has been intuitively known since I was commissioned in 1992.

My peers and I were told at OBC that we were an underaccessed YG to start with based on predictive models of what the Army would look like in 2007 (our 15 year mark) and 2012 (our 20 year mark, assuming no prior service). This was during the downsizing era where the Army went from mid 600K endstrength to high 400K endstrength in about 3-4 years. This is bearing itself out in promotion percentages ("almost all of you who stay in for a career will make LTC"). This was also before the single-track career fields opened with OPMS III (or XXI) enacted in 1997.

Then they let guys and gals out at the two year mark. Worked out well for me on a personal level as I met my wife through a USMA classmate who was out and in business school with her.

Then we had higher than projected "attrition" from 1997 to 2001 (so the so-called CPT's Retention Crisis is not really new). The now laughable (in terms of supposed force strain) 6-month rotations to Bosnia and Kosovo were considered to be a contributing factor, but I know more than a few guys (meat-eaters) who thought the future of the Army was peace operations of the sort and weren't too fond of that as the hallmark of their careers.

I expect we will see promotion rates to O6 in the low 80s in the next 5-6 years as these year groups make their way to that threshold.

I know more than a few former battalion commanders (MFE-types), right now, who are using O6-level command selection as their decision point to retire. No one is too fired up about being the MNF-I CHOPS, post SSC, with the work load, separation (combat tour four or five for most), and utter mental pain that job, and others like it entails, for the pay raise and silver eagle when the civilian sector is very much hiring guys, with juicy compensation packages, who have O5 level command experience.

Great work, George. Live the Legend.

RE: Major Crisis - How do we retain Majors?

Friday Last Week 1:51 AM

YG 94 Infantryman here currently serving in Afghanistan as a Police Mentor Team chief immediately following ILE (was slated to go to Alaska to run a staff or plan operations

for a Stryker BN). I'd like to think that I represent a likely candidate to be a card-carrying member of the disenfranchised...however, I have no intention of leaving the service early IF I'm competitive at 20. If I'm not competitive at 20, then only some lucrative financial incentives would keep me hanging around to slog away as a COL specializing in staff operations. Otherwise, I'm passing up opportunities in the civilian world, namely a second retirement. To get back on target, although I can't say I represent all of my unit peers, I can say confidently that we have shared frustrations with NATO partners, field ordering officer procedures in OEF, theater personnel management (very problematic), mobilized units who receive little to no focused training prior to arrival (specifically, staff operations for major AOs)and the lack of responsive enablers. None of these are sufficient to make me get out. However, they're like a low-grade fever that significantly impacts the overall health of the organism. In summary, I'm not getting out despite having to scramble to learn police business this year and adjust fire from where I expected to be (S3/XO in an MTOE unit) but I understand well the conditions that drive some guys to the door.

Cheers

RE: Major Crisis - How do we retain Majors?

Friday Last Week 8:15 AM

Excellent survey document of your work. The summary only validates what I see. I have personally seen four of our peers pop smoke on the army in the last six months. Why? Family and a future drove the train for those guys. They wanted to start careers while they are young and wanted to be with their spouse. They talked about too much time from home, etc. Money was talked about but was not the driving force that I thought it would be. Talking with my wife, money is not the major factor either. She has a degree too and is raising our three boys without me at times. She would give up money to have me around more.....interesting huh.

The "MAJ CRISIS" summary is good and hits the main points for year group 91-97.

WELL DONE MAJ BROWN

85 majors performing the work of 100.

Thursday Last Week 7:41 PM

Interesting. I look forward to reading your final product. Your information appears sound. Will the Army promote early the LTC? Most of us are still on the old school system of 2 years to 1LT, 4 years to CPT, 11 years to MAJ, 17 years to LTC. By the way our BCT has 1LT/CPTs commanding at 3 years. There is a big experience gap between today's company grade and field grade officers.

RE: Major Crisis - How do we retain Majors?

Friday Last Week 8:40 PM

Few incentives have been given to the officers who have worked in the shortage their whole career (YG 91-97)... what ever happened to “mission first, people always”? These year groups have sacrificed a lot (big understatement) for the missions, so when does the US Army/HRC take care of these people? Is it too late – has the decisions already been made by the Army families? And if we are in such a bad situation, will the US Army/HRC solve it by just refusing requests for retirement at 20 years? What happened to our leadership (classic definition from FM 6-22 / AR 600-100)? I surmise we have managers at HRC and not leaders...

RE: Major Crisis - How do we retain Majors?

Friday Last Week 8:17 AM

Based on your survey response rate of 52.82% (412/780) from a business world perspective is nothing short of amazing. Most e-mail survey responses, even when to a unique target market, have a response rate of 5-10% as do targeted direct mail campaigns. Also, offering the survey to 5.2% of the Major population makes this a statistically relevant group. Finally, a third party supervised the survey distribution and collection. From a pure academic and business oriented statistical review, there is absolutely nothing wrong with this process. I would like to see the specific criticism that the US Army has of the survey because you could say that the survey has even more relevance based on the population who took the survey because they are the ones the US Army wants most to retain.

RE: Major Crisis - How do we retain Majors?

Friday Last Week 12:32 PM

Maj Brown,

It should not surprise you that the Big Army attempts to discredit your work. It took them considerable time in the mid 90s to figure out there was a Captain Crisis, and that was only after considerable denial. I personally appreciate your effort and honesty in bringing up the issue. I hope the politics of it all does not adversely affect you. The truth about institutions is generally not well received by those at the top.

Good luck and Thank you for your hard work and honesty

MAJ ILE 09-01

RE: Major Crisis - How do we retain Majors?

Today 12:34 PM

This executive summary brings up a few points that come to mind. First, the Army relies too heavily on monetary incentives to retain individuals. Second, the Army doesn't utilize

the reserve pool enough to fill shortcomings. I have not done nearly the amount of research MAJ Brown has done on the subject, but these are merely the comments of a YG97 officer that has run the gambit of Active Duty, IRR, USAR TPU, USAR AGR, and now finally back Active Duty again. Retention is just not an Army specific problem. My first point of the Army relying too much on monetary incentive probably is a little misleading. Money is good and is an incentive, but the value that a monetary incentive brings is ever lasting. It doesn't matter if it's in the civilian sector or in the military. Money comes and it goes. Organizations in general do not place enough emphasis on building those intrinsic values that lead to selfless service. There is a trend in Generation X, Y or whatever you want to call them, to go towards the "what's in it for me" (WIIFM) mentality that you don't see in early generations such as the Baby Boomers. Fulfilling this WIIFM mentality is much easier said than done, but needs to be addressed. Organizations have been engaging students as earlier as their high school years to build a program internally to address retention issues.

My second point of not utilizing the Reserve system to fill shortcomings may also be a little deceptive at first glance also. I understand that the USAR has been more in recent history than in the past. However, the vast majority of these mobilizations are "complete" units and are in support of deploying units. The other percentages of mobilization are individual augmentees for the most part. Unless a soldier is in the know, it is hard to find these positions advertised. The Call to Active Duty (CAD) program is also available, but in my experience those Reserve/Guard officers who are interested in submitting a CAD packet are hesitant because the assignment process is vague at best. Why not advertise shortages better or make the CAD process a bit more transparent? The economy is at a point that is a Reserve/Guard soldier gets let go from their civilian job, they will start looking to the military for a quick stop gap. A quick 179 day tour of active duty to pay the bills, maybe help out the unit a bit, but where is the utility in that for the Army as a whole? Retain the soldier for a couple more months or years? It seems to be a waste of resources to me.

I don't want to come across as a neigh-sayer. I came back Active Duty because I recognized that I enjoy being a professional soldier. I have also performed retention/recruiting duties in both a military and civilian capacity. It's not an easy field and it takes a lot of resources to keep it functioning adequately. It's a great discussion that will take folks a lot smarter than I am to fix.

## REFERENCE LIST

- Aswell, Paul L. Colonel, Chief, US Army HRC Officer Division, DAPE-MPO. 2008. Telephone interview. (14 May)
- Chief, US Army HRC Officer Division, DAPE-MPO. 2008. Telephone interview. (17 June)
- Chief, US Army HRC Officer Division, DAPE-MPO. 2008. Telephone interview. (27 June)
- Army Regulation 135–32. 2004. *Retention in an Active Status after Qualification for Retired Pay*. Army National Guard and Army Reserve (May).
- Army Regulation 220-1. 2006. *Unit Status Reporting*. (December)
- Army Regulation 600-8-29. 2005. *Officer Promotions*. (March)
- Army Regulation 601–280. 2006. *Personnel Procurement; Army Retention Program* (January).
- Beerman, Kevin LTC. 2006. *Increasing Army Retention Through Incentives*. USAWC Strategy Research Project.
- Bryan Bender and Renee Dudley. 2007. *Army rushes to promote its officers War pressures cited; quality is a concern*. The Boston Globe.  
[http://www.boston.com/news/nation/articles/2007/03/13/army\\_rushes\\_to\\_promote\\_its\\_officers/](http://www.boston.com/news/nation/articles/2007/03/13/army_rushes_to_promote_its_officers/) (accessed 5 July 2008)
- Commission on the National Guard and Reserves, Transforming the National Guard and Reserves into a 21st-Century Operational Force*. 2008.  
[http://www.cngr.gov/Final%20Report/CNGR\\_final%20report%20with%20cover.pdf](http://www.cngr.gov/Final%20Report/CNGR_final%20report%20with%20cover.pdf) (accessed 17 June 2008)
- Congressional Budget Office. 2006. *Recruiting, Retention, and Future Levels of Military Personnel*. The Congress of the United States.

- Crist, Angela M., 2006 . Policy Analysis: Factors that Influence Spouses to Support their Soldier to Continue Serving the United States Army. Central Michigan University
- Donnelly, Thomas and Kagan, Frederick. 2008. *Ground Truth: The Future of U.S. Land Power*. Washington, D.C.: American Enterprise Institute.  
[http://www.aei.org/books/bookID.934/book\\_detail.asp](http://www.aei.org/books/bookID.934/book_detail.asp) (accessed 17 June 2008)
- Dreazen, Yochi J. 2008. *Army Effort to Retain Captains Falls Short of Goal*. Wall Street Journal (26 January)
- Duffy, Michael. 2007. *Amid the Surge, an Army's Shortage*. Time.Com.  
<http://www.time.com/time/magazine/article/0,9171,1627030,00.html> (accessed 5 July 2008)
- Eaglen, Mackenzie. 2008. *Paying for America's All-Volunteer Military: "Reform" Is Not a Dirty Word*. The Heritage Foundation.  
<http://www.heritage.org/Research/NationalSecurity/bg2144.cfm> (accessed 17 June 2008)
- Fricker Jr., Ronald D. 2002. *The Effects of Perstempo on Officer Retention in the U.S. Military*. National Defense Research Institute, Prepared for the Office of the Secretary of Defense. RAND.
- Garamone, Jim. 2008. *Panel Recommends Changes to Military Retirement*. American Forces Press Service.  
<http://www.defenselink.mil/News/newsarticle.aspx?id=50702> (accessed 22 August 2008)
- General Casey, George (Chief of Staff Army). 2008. Brief to CGSC/ILE Classes 08-01 and 08-02 (March).
- General Casey, George (Chief of Staff Army). 2008. Senate Armed Service Committee hearing (February)

- Goldich, Robert L. 2002. *The Military Draft and a Possible War with Iraq*. Congressional Report Service Report for Congress (December)
- Government Accounting Office. 2007. *Strategic Plan Needed to Address Army's Emerging Officer Accession and Retention Challenges* (January).
- Government Accountability Office, Military Personnel. 2005. *DOD Needs to Improve the Transparency and Reassess the Reasonableness, Appropriateness, Affordability, and Sustainability of the Military Compensation System*. (July)
- Henning, Charles A. 2006. *Army Officer Shortages: Background and Issues for Congress*. Congressional report; Library of Congress. Washington DC Congressional Research Service (5 July).
- Information Paper. 2008. *US Army Posture Statement*.
- Ingras, Douglas LTC. 2007. *Army Officer Menu of Incentives Program FY07/08*. Officer Retention Branch (29 October).
- Kennedy, John F., Remarks at the Convocation of the United Negro College Fund, Indianapolis, Indiana, April 12, 1959.  
[http://www.jfklibrary.org/Historical+Resources/Archives/Reference+Desk/Speeches/JFK/JFK+Pre-Pres/189POWERS09JFKPOWEES\\_59APR12.htm](http://www.jfklibrary.org/Historical+Resources/Archives/Reference+Desk/Speeches/JFK/JFK+Pre-Pres/189POWERS09JFKPOWEES_59APR12.htm) (accessed 31 July 2008)
- Neff, Joseph and Price, Jay. 2005. *Contractors in Iraq make costs balloon; Extensive paramilitary work earns profit on several levels*. The News & Observer. [www.newsobserver.com/917/story/241329.html](http://www.newsobserver.com/917/story/241329.html) (accessed 11 July 2008)
- Peters, Katherine McIntire. 2007. *Looking for Leaders*. Government Executive (1 August)
- Pincus, Walter. 2007. *U.S. Pays Steep Price for Private Security in Iraq*. The Washington Post. Page A17. (1 October)

Powers, Ron. 2008. *Understanding Military Retirement Pay*. About.com: US Military <http://usmilitary.about.com/cs/generalpay/a/retirementpay.htm> (accessed 23 May 2008)

Regan, Tom. 2006. *'Backdoor Draft'? Critical shortage' prompts involuntary recall of reservists*. The Christian Science Monitor. <http://www.csmonitor.com/2006/0823/dailyUpdate.html> (accessed 5 July 2008)

*Report of the Tenth Quadrennial Review of Military Compensation*. 2008. <http://www.defenselink.mil/releases/release.aspx?releaseid=11747> (accessed 17JUN08)

*The Report of the President's Commission on an All-Volunteer Armed Force*. 1970. <http://www.rand.org/pubs/monographs/MG265/images/webS0243.pdf> (accessed 17 June 2008)

Roberts, Kristin. 2007. U.S. Army faces shortage of junior officers-memo. Reuters. <http://www.alertnet.org/thenews/newsdesk/N14325579.htm> (accessed 5 July 2008)

Rochelle, Michael D. LTG. 2007. *Supporting Commanders, Serving Soldiers, Sustaining Families*. Army G-1; Worldwide Retention Conference (30 October).

*Soldiers Magazine*. 2008. The Official U.S. Army Magazine. Gateway Press, Inc. (January)

*Soldiers Magazine*. 2007. The Official U.S. Army Magazine. Gateway Press, Inc. (January)

*Soldiers Magazine*. 2006. The Official U.S. Army Magazine. Gateway Press, Inc. (January)

Statistical Survey. Wikipedia. [http://en.wikipedia.org/wiki/Statistical\\_survey](http://en.wikipedia.org/wiki/Statistical_survey). (accessed 22 August 2008)

Stewart Derek B. 2005. *Preliminary Observations on Recruiting and Retention Issues within the U.S. Armed Forces*. Defense Capabilities and Management (March).

- Stringer, Kevin D. 2008. *The War on Terror and the War for Officer Talent: Linked Challenges for the U.S. Army*. The Land Warfare Papers, Number 67. (July)
- Taylor-Powell, Ellen. 1998. *Sampling*. Madison, WI: University of Wisconsin-Extension, Cooperative Extension.
- Tilghman, Andrew. 2007. *The Army's Other Crisis; why the best and brightest young officers are leaving* (December).
- Tyson, Ann Scott. 2007. *Army Offers Big Cash To Keep Key Officers*. WashingtonPost.com. <http://www.washingtonpost.com/wp-dyn/content/article/2007/10/10/AR2007101002689.html> (accessed 11 July 2008)
- Tyson, Ann Scott. 2008. *Deployments Are a Factor in Army's Deficit of Majors*. The Washington Post, A4 (August).
- U.S. Army G-1. 2007. U.S. Army Officer Retention Fact Sheet.
- U.S. Army G-1. 2008. U.S. Army Officer Retention Fact Sheet.
- USA Today. 2008. *US Deaths in Iraq: A Personal, Statistical View*. [http://www.usatoday.com/news/world/iraq/2008-03-13-iraq-casualties\\_N.htm](http://www.usatoday.com/news/world/iraq/2008-03-13-iraq-casualties_N.htm). (accessed 5 June 2008)
- Warner, John T. and Pleeter, Saul. 2001. *The Personal Discount Rate: Evidence from Military Downsizing Programs*. The American Economic Review. <http://www.jstor.org/stable/pdfplus/2677897.pdf> (accessed 17 June 2008)
- Wong, Leonard Dr. 2007. *Is it Time to Mandate Volunteerism?* Strategic Studies Institute (December).

Wormuth, Christine E. 2006. *The Future of the National Guard and Reserves: The Beyond Goldwater–Nichols Phase III Report*. Center for Strategic and International Studies.  
[http://www.csis.org/component/option,com\\_csis\\_pubs/task,view/id,3338](http://www.csis.org/component/option,com_csis_pubs/task,view/id,3338) (10 June 2008).

## INITIAL DISTRIBUTION LIST

Combined Arms Research Library  
U.S. Army Command and General Staff College  
250 Gibbon Ave.  
Fort Leavenworth, KS 66027-2314

Defense Technical Information Center/OCA  
825 John J. Kingman Rd., Suite 944  
Fort Belvoir, VA 22060-6218

LTG William B. Caldwell IV  
CDR, Command Arms Center and Ft Leavenworth  
Fort Leavenworth, KS 66027-1352  
[William.CaldwellIV@us.army.mil](mailto:William.CaldwellIV@us.army.mil)

Dr. Ralph O. Doughty, Ph.D  
Transformation Department  
USACGSC  
Lewis and Clark Center  
Fort Leavenworth, KS 66027-1352

COL William M. Raymond, Jr., Ph.D  
USACGSC  
Lewis and Clark Center  
Fort Leavenworth, KS 66027-1352

COL(R) David Hunter-Chester  
Staff Group 5/B  
USACGSC  
Lewis and Clark Center  
Fort Leavenworth, KS 66027-1352

Dr. Robert F. Baumann  
USACGSC  
Lewis and Clark Center  
Fort Leavenworth, KS 66027-1352

Dr. Constance A. Lowe  
USACGSC  
Lewis and Clark Center  
Fort Leavenworth, KS 66027-1352

Dr. Bill J. McCollum  
USACGSC

Lewis and Clark Center  
Fort Leavenworth, KS 66027-1352

LTC Justin Kidd  
Chief of Student Division  
USACGSC  
Lewis and Clark Center  
Fort Leavenworth, KS 66027-1352

MG Sean J. Byrne  
US Army HRC CG  
[Sean.Byrne@us.army.mil](mailto:Sean.Byrne@us.army.mil)

BG Rodney L. Johnson  
US Army Provost Marshal General  
[rod.johnson@us.army.mil](mailto:rod.johnson@us.army.mil)

COL Paul L. Aswell  
US Army HRC, Officer Division  
[Paul.Aswell@hqda.army.mil](mailto:Paul.Aswell@hqda.army.mil)

MAJ Derek F. Burt  
HRC, Manpower Distribution Analyst  
[Derek.Burt@us.army.mil](mailto:Derek.Burt@us.army.mil)

Dr Fred Milano  
Professor Emeritus of Sociology, Appalachian State University  
[milanofa@appstate.edu](mailto:milanofa@appstate.edu)

Mr. Rick Steele  
USACGSC  
Lewis and Clark Center  
Fort Leavenworth, KS 66027-1352

Ms. Maria Clark  
USACGSC  
Lewis and Clark Center  
Fort Leavenworth, KS 66027-1352

Dr. Bitters  
USACGSC  
Lewis and Clark Center  
Fort Leavenworth, KS 66027-1352

Major Mike Wise  
41 Rose Loop  
Ft Leavenworth, KS 66027

George B. Brown Jr.  
[gbbrown@boone.net](mailto:gbbrown@boone.net)

Ann Scott Tyson  
Military and Pentagon Correspondent  
The Washington Post  
[tysona@washpost.com](mailto:tysona@washpost.com)

Military Review  
US Army Command and General Staff College  
294 Grant Avenue, Building 77  
Fort Leavenworth, KS 66027-1254

*George B. Brown III is an active duty major in the US Army. He entered the Army in 1990, became an NCO in 1992 and a commissioned officer in 1995. His deployments include Operation Desert Shield/Storm in Kuwait/Saudi Arabia/Iraq; Operation Provide Comfort in Iraq; Stabilization Force (SFOR) in Bosnia-Herzegovina/Hungary; and Operation Iraqi Freedom in Iraq. He has also spent nine years stationed in Europe. He graduated from Appalachian State University (BS), Webster University (MA), and is currently a graduate student in the US Army Command and General Staff College in Ft Leavenworth, KS. He can be reached at [Brown-George@US.Army.mil](mailto:Brown-George@US.Army.mil)*