

SPACECRAFT SIGNAL SOURCES PORTABLE TEST SYSTEM*

Albert Kirk, Paul Kuhnle, Richard Sydnor
William Diener and David Stowers

California Institute of Technology
Jet Propulsion Laboratory
Pasadena, California 91109

Abstract

There is a frequent need to measure the frequency stability and phase noise levels of very high performance signal sources that are required for certain spacecraft missions. These measurements need to be done at different locations as the spacecraft subsystems progress through the various stages of development, assembly, test and integration.

Allan Deviation and Phase Noise of high performance sources are generally measured by comparing the unit under test to a reference standard. Five basic requirements are associated with making these kind of measurements:

- 1. The reference standard performance needs to be equal or better than the unit under test.*
- 2. The measurement system needs to accommodate odd, non-standard measurement frequencies that can range from 4 MHz to 35 GHz.*
- 3. Warm-up frequency drift and aging can corrupt a measurement and must be dealt with.*
- 4. Test equipment generated noise must be understood and prevented from limiting the measurements.*
- 5. Test equipment noise performance must be verifiable in the field as needed.*

This paper describes a portable measurement system that has been built by JPL and used in the field. The methods of addressing the above requirements are outlined and some measurement noise floor values are given.

This test set has recently been used to measure state of the art crystal oscillator frequency standards on the TOPEX and MARS OBSERVER spacecraft during several stages of acceptance tests.

INTRODUCTION

The Frequency Reference Unit (FRU) of the Topex/Poseidon spacecraft and the Ultrastable Oscillator (USO) of the Mars Observer spacecraft are high performance signal sources that needed to be measured in their final environment to assure compliance with previously established specifications.

*This work represents one phase of research carried out at the Jet Propulsion Laboratory, California Institute of Technology, under a contract sponsored by the National Aeronautics and Space Administration.

Report Documentation Page

Form Approved
OMB No. 0704-0188

Public reporting burden for the collection of information is estimated to average 1 hour per response, including the time for reviewing instructions, searching existing data sources, gathering and maintaining the data needed, and completing and reviewing the collection of information. Send comments regarding this burden estimate or any other aspect of this collection of information, including suggestions for reducing this burden, to Washington Headquarters Services, Directorate for Information Operations and Reports, 1215 Jefferson Davis Highway, Suite 1204, Arlington VA 22202-4302. Respondents should be aware that notwithstanding any other provision of law, no person shall be subject to a penalty for failing to comply with a collection of information if it does not display a currently valid OMB control number.

1. REPORT DATE DEC 1992		2. REPORT TYPE		3. DATES COVERED 00-00-1992 to 00-00-1992	
4. TITLE AND SUBTITLE Spacecraft Signal Sources Portable Test System				5a. CONTRACT NUMBER	
				5b. GRANT NUMBER	
				5c. PROGRAM ELEMENT NUMBER	
6. AUTHOR(S)				5d. PROJECT NUMBER	
				5e. TASK NUMBER	
				5f. WORK UNIT NUMBER	
7. PERFORMING ORGANIZATION NAME(S) AND ADDRESS(ES) California Institute of Technology, Jet Propulsion Laboratory, Pasadena, CA, 91109				8. PERFORMING ORGANIZATION REPORT NUMBER	
9. SPONSORING/MONITORING AGENCY NAME(S) AND ADDRESS(ES)				10. SPONSOR/MONITOR'S ACRONYM(S)	
				11. SPONSOR/MONITOR'S REPORT NUMBER(S)	
12. DISTRIBUTION/AVAILABILITY STATEMENT Approved for public release; distribution unlimited					
13. SUPPLEMENTARY NOTES See also ADA267301. 24th Annual Precise Time and Time Interval (PTTI) Applications and Planning Meeting, McLean, VA, 1-3 Dec 1992					
14. ABSTRACT see report					
15. SUBJECT TERMS					
16. SECURITY CLASSIFICATION OF:			17. LIMITATION OF ABSTRACT	18. NUMBER OF PAGES	19a. NAME OF RESPONSIBLE PERSON
a. REPORT	b. ABSTRACT	c. THIS PAGE			
unclassified	unclassified	unclassified	Same as Report (SAR)	11	

The objective was to design and build a portable measurement system that would meet the following requirements:

- A. Perform all required measurements on the Mars Observer USO and the Topex/Poseidon FRU at designated spacecraft assembly and checkout facilities including thermal/vacuum and pre launch sites.
- B. Measure output frequencies of 4.096 MHz, 5.00 MHz and 19.056 MHz on the FRU; at 0 dBm \pm 5 dB power levels.
- C. Measure the transmitter output at 8.423 GHz and 8.417 GHz on the Mars Observer spacecraft. Power levels range from -70 dBm to +10 dBm depending on configuration and modulation.
- D. Use existing equipment and available commercial instruments when possible for maximum cost effectiveness.
- E. Avoid customizing in order to reconfigure and reuse equipment for future tests.
- F. Provide flexibility to facilitate unexpected last minute changes in scope when in the field.
- G. Simplify and minimize calibration procedures as much as possible without sacrificing confidence and accuracy.

REQUIRED MEASUREMENTS

1. ALLAN DEVIATION, $\tau=1$ s to $\tau=10000$ s
2. PHASE NOISE, AT 1 Hz to 10 KHz OFFSETS FROM THE CARRIER
3. DETECTION OF SPURIOUS, UNDESIRABLE PHASE MODULATION
4. DETECTION OF CROSSTALK
5. DETECTION OF ENTRAINMENT
6. AGING
7. WARM-UP CHARACTERISTICS
8. ABSOLUTE FREQUENCY

SPECIFICATIONS

It is beyond the scope of this paper to list all specifications. Figures 1 and 2 show typical Allan Deviation and Phase Noise for the signal sources under test. It is evident that these are extremely low noise crystal oscillator units.

BASIC APPROACH

We decided to use the mixer/phase detector method of comparing the UUT to available references. The block diagram in Figure 3 shows the basic test configuration.

Phase noise measurements are made by establishing phase quadrature between the two mixer inputs. The DC voltage fluctuations at the output are proportional to phase noise between the two input signals. With proper calibration and processing the spectral density of phase can be measured directly with a commercial spectrum analyzer at the required offset frequencies. The detailed procedures and limitations of this method are well documented in the literature.[1, 2] Continuous observation of these phase fluctuations can detect crosstalk and other spurious undesirable phase modulation on the unit under test.

Allan Deviation, Frequency Offset, Frequency and Phase Residuals are measured by establishing a 1Hz beat between the two mixer inputs. The Zero Crossing Detector (Z/C) provides a fast, one time only, transition at this beat period which can be counted to yield frequency offset data at selected averaging times. In our system, the output of the Z/C is also fed to a time interval counter which measures the time difference between each positive going or negative going zero crossing transition and subsequent 10 PPS pulse. This is known as the "Picket Fence" method of measuring the Allan Deviation. This process also yields residual phase and frequency data in the time domain.[3]

There are five basic requirements associated with making these kind of measurements.

1. The reference source must be equal or better than the UUT.
2. The system must accommodate the output frequency of the UUT.
3. The mixer noise must not limit the measurement sensitivity.
4. The UUT. must not drift too much. (See explanation below)
5. Test system performance must be verifiable in the field.

(Allan Deviation measurements are corrupted if tau is not held constant during the duration of the test. A rule of thumb is to maintain the minimum tau at $1 \text{ s} \pm .01\text{s}$. For a 12 hour test run this would require a frequency offset drift between the reference and the UUT of less than $2.4 \times 10^{-12}/\text{day}$ at 8.4 GHz. At a 5 MHz test frequency, this requirement diminishes to about $4 \times 10^{-9}/\text{day}$.)

AVAILABLE REFERENCES

Figure 4 shows the Allan Deviation of four different reference standards that were available to us. Also shown are the typical specified and expected values of the units under test. Only the Hydrogen

Maser qualifies as the reference that is equal or better than the units under test. Although Hydrogen Masers are portable, the costs and time factors associated with moving one from site to site was unacceptable. The high performance Cesium is not good enough over the tau range of interest. A compromise solution was adopted by splitting each Allan Deviation test into two parts. For tau values of less than 50 s the Crystal Oscillator was used; and for tau values of greater than 50 s the Rubidium Standard was used as the reference. The Rubidium also qualified as the absolute frequency measurement Standard. Although, the exact performance of the units under test could not be established in the field, it was acceptable to verify that the units met the minimum specified performance.

LOW FREQUENCY TEST SYSTEM CONFIGURATION

Figure 5 shows the Low Frequency Test System Configuration that was used to measure the Topex/Poseidon FRU signal characteristics. Each output signal was multiplied to about 95 MHz and mixed with the 100 MHz reference signal. This way we achieved two objectives: The noise contribution of the first mixer was not significant at this frequency and the use of a synthesizer at the 5 MHz intermediate frequency provided for the correct 1Hz offset capability at each test frequency with 0.1 Hz resolution. It should be noted that we could not find a synthesizer that could be used directly at the first mixer input because of noise limitation. A Fluke model 6160B was tested and found to be acceptable at the 5 MHz intermediate frequency. Frequency drift at the 95 MHz level was no problem once the system was warmed up.

The system was tested in the field as often as needed by measuring the known 5 MHz test oscillator and or by feeding the 5 MHz reference into the x19 configuration multiplier. Phase Noise, Crosstalk and Spurious Signals were measured by closing the loop with a less than 1Hz BW and using the 5 MHz VCO as the reference.

Allan Deviation, Frequency Offset, Frequency and Phase Residuals, Entrainment, Aging and Warmup Characteristics were measured with the loop open using the free running VCO or the Rubidium as a reference.

HIGH FREQUENCY TEST SYSTEM CONFIGURATION

Figure 6 shows the High Frequency Test System Configuration used to measure the Mars Observer Transmitter output at 8.423 and 8.417 GHz. Aging and warmup characteristics were estimated to be at least 5×10^{-11} per day. The corresponding frequency drift at 8.4 GHz during a 12 hour period is .21Hz. It turned out during actual testing that the drift was often much more because of unscheduled power off/on cycles. The configuration of Figure 6 solved this problem by effectively dividing the 8.4 GHz output to a lower frequency for Allan Deviation measurements. This was done by hardlocking the precision 5 MHz VCO to the 8.42 GHz test signal. Any convenient multiple of this 5 MHz, such as the 100 MHz output shown, preserves the inherent stability of the signal input within the loop bandwidth. The Allan Deviation, Frequency Offset, Frequency and Phase Residuals, Entrainment, Aging and Warmup Characteristics were measured at 100 MHz against either the Rubidium or Crystal Oscillator Reference. Thus we were able to maintain the beat frequency within limitations. Mixer and synthesizer noise contributions are negligible at these frequencies and frequency ratios.

The system noise floor and the x84/ref multiplier noise levels were measured in the field as needed to verify measurement system integrity. (See Figures 7 & 8)

UNIVERSAL LOW NOISE FREQUENCY MULTIPLIER

Figure 9 shows the Frequency Multiplier Module that was used. External, high isolation distribution amplifiers are not shown. A string of x2 sections, each consisting of a commercial 2way power splitter and frequency doubler, followed by a JPL designed low temperature coefficient bandpass filter and high isolation amplifier are mounted inside a magnetically shielded box. The input to each x2 is +10 dBm. The bandwidth and center frequency of the 5 pole filters are chosen so that with a minimum number of units a large range of input frequencies and multiplication factors can be configured in the field by simply selecting the appropriate bandpass filter. The noise of this multiplier is well below Hydrogen Maser levels. We use this multiplier with input frequencies in the range of 1 to 50 MHz and output frequencies in the range of 10 to 500 MHz.

REFERENCES

- [1] Allan, D.W., Shoaf, J.H., and Halford, D., "*Statistics of Time and Frequency Data Analysis*", chap. 8, Time and Frequency: Theory and Fundamentals (B.E. Blair, ed.), 1974, National Bureau of Standards Monograph No. 140, pp 151-204.
- [2] Walls, F.L., Felton, C.M., Clements, A.J.D., "*Accuracy Model for Phase Noise Measurements*", Proceedings of the 21st Annual Precise Time and Time Interval (PTTI) Applications and Planning Meeting, 28-30 November, 1989, Redondo Beach, CA, pp 295-312.
- [3] Greenhall, C.A., "*A Method for Using a Time Interval Counter to Measure Frequency Stability*", IEEE Trans. on Ultrasonics, Ferroelectrics, and Frequency Control, UFFC-36, No 6, September 1989.

SPECIFICATIONS

Figure 1. ALLAN DEVIATION

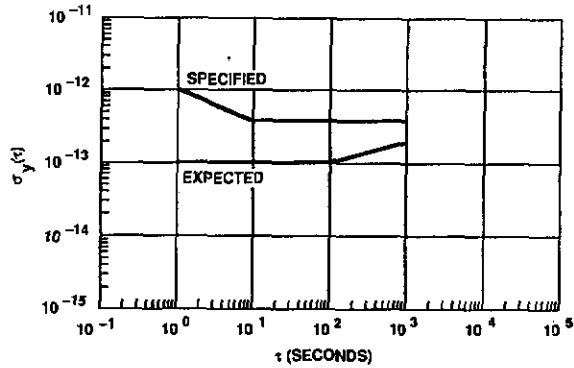

Figure 2. PHASE NOISE, NORMALIZED TO 5 MHz

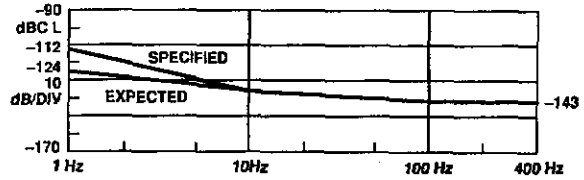
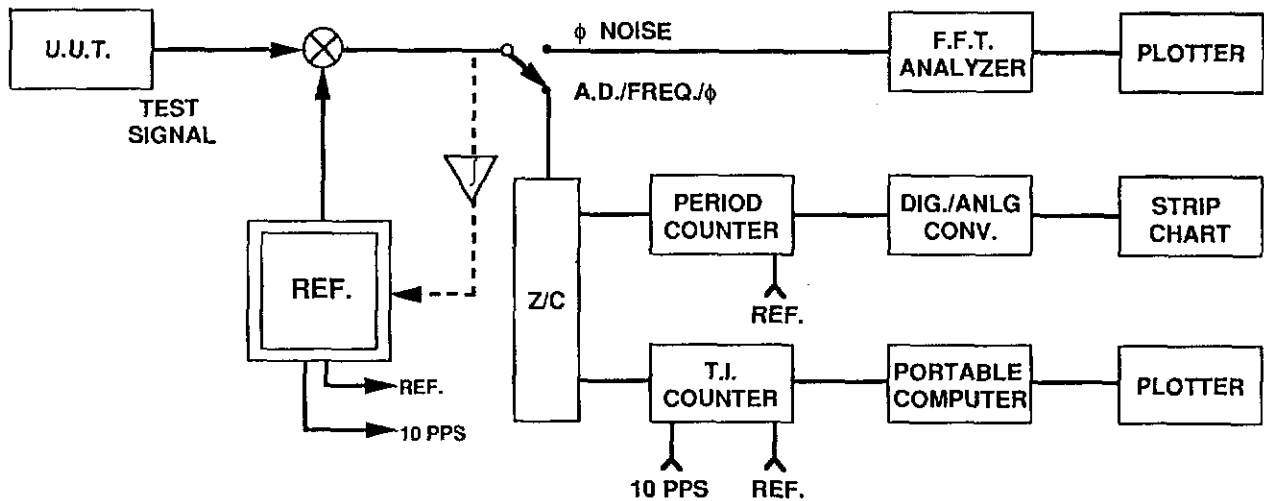

Figure 3. BASIC TEST CONFIGURATION



WHAT ARE THE PROBLEMS?

1. U.U.T. MUST NOT DRIFT TOO MUCH
2. MIXER NOISE MUST NOT LIMIT MEASUREMENT
3. REF. SOURCE MUST BE EQUAL OR BETTER THAN U.U.T.
4. SYSTEM MUST ACCOMMODATE OUTPUT FREQ. OF U.U.T.
5. MEASUREMENT SYSTEM PERFORMANCE MUST BE VERIFIABLE

Figure 4. AVAILABLE REFERENCES

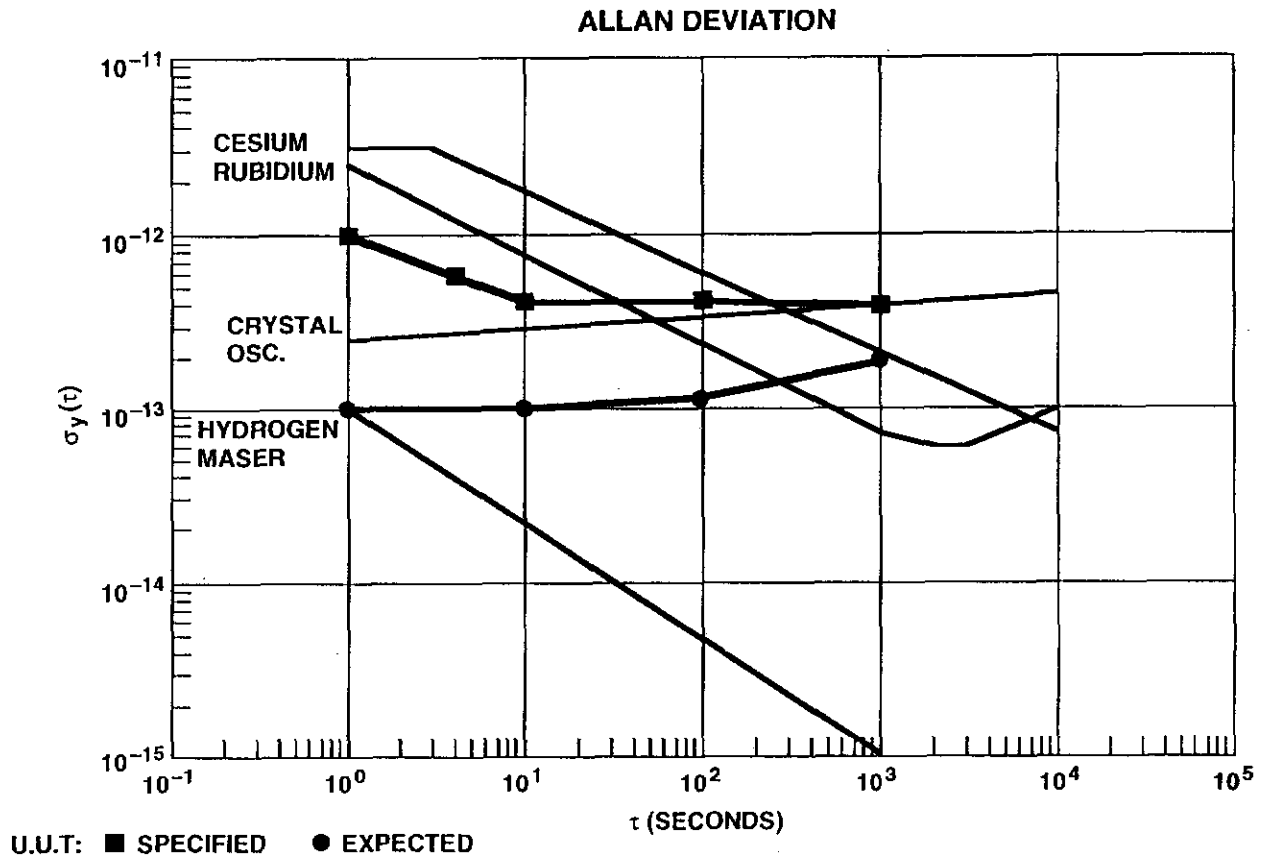

Figure 5. LOW FREQUENCY TEST SYSTEM CONFIGURATION

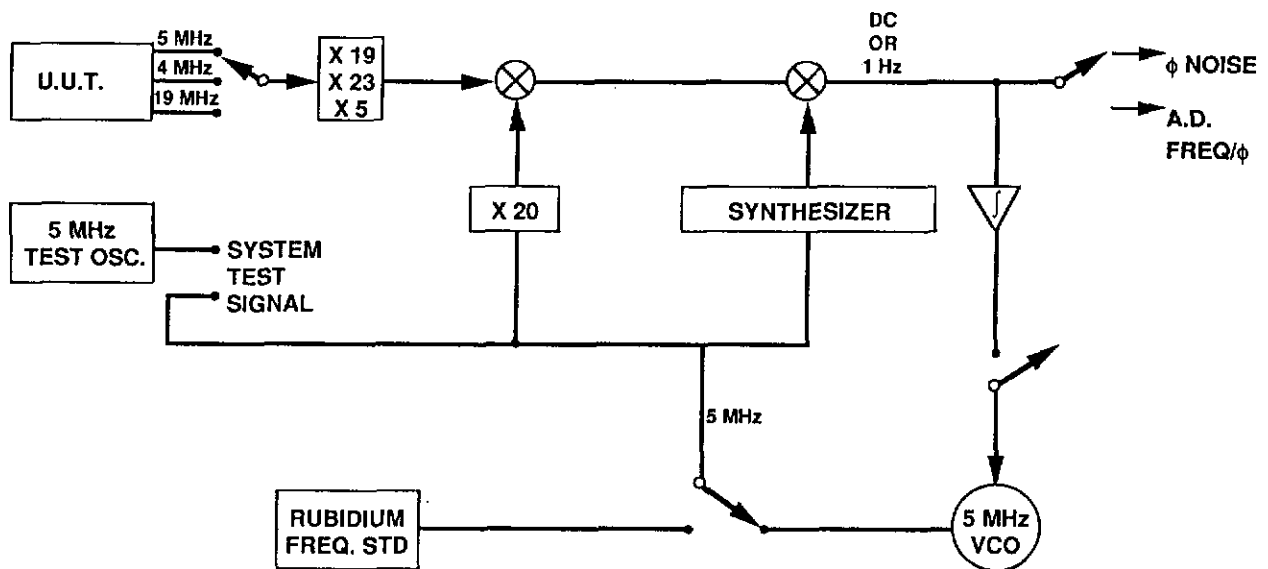

Figure 6. HIGH FREQUENCY TEST SYSTEM CONFIGURATION

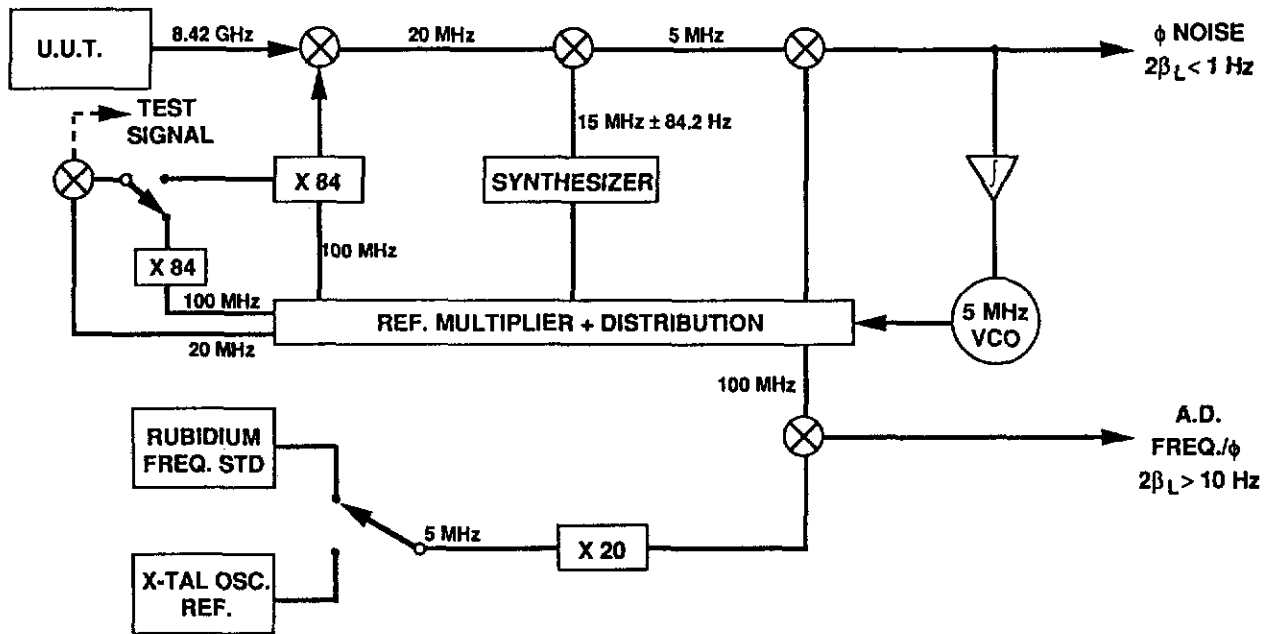

Figure 7. TEST SYSTEM NOISE FLOOR AT 8.42 GHz

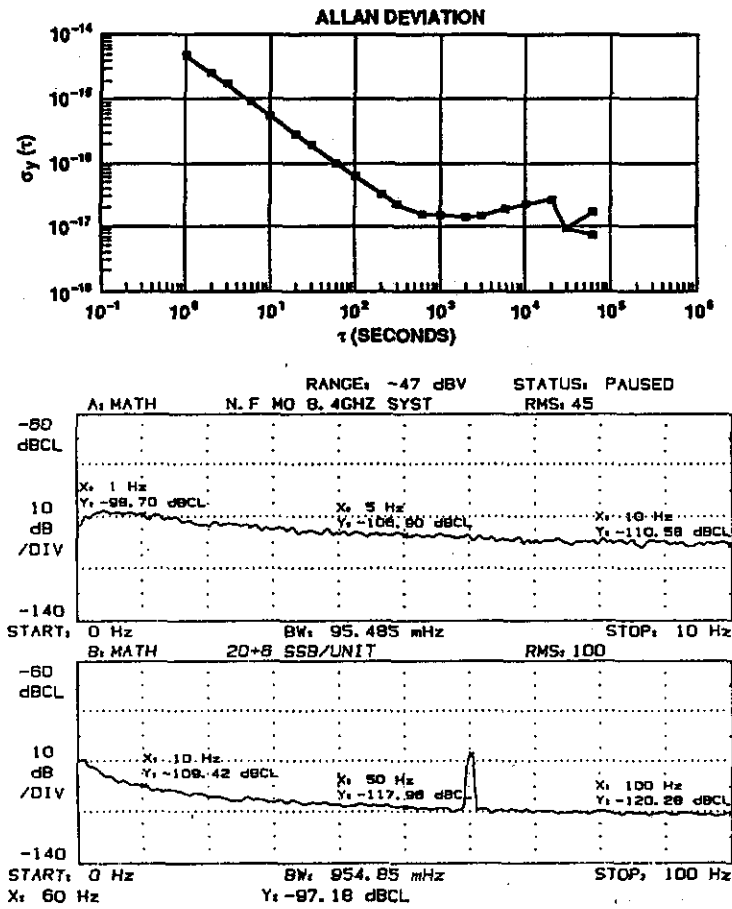

Figure 8. x 84 MULTIPLIER NOISE AT 8.4 GHz

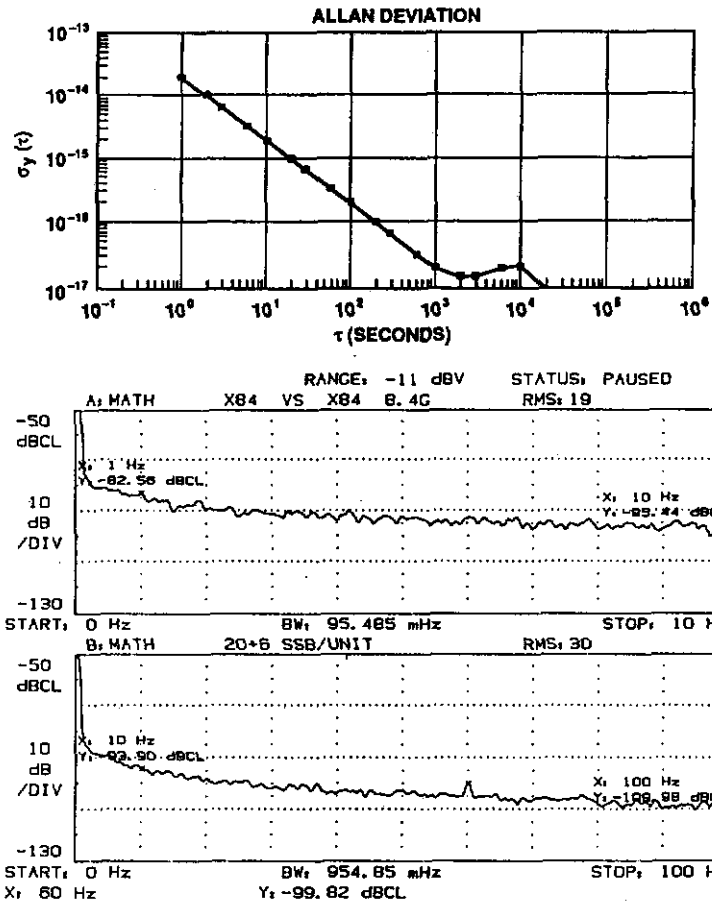
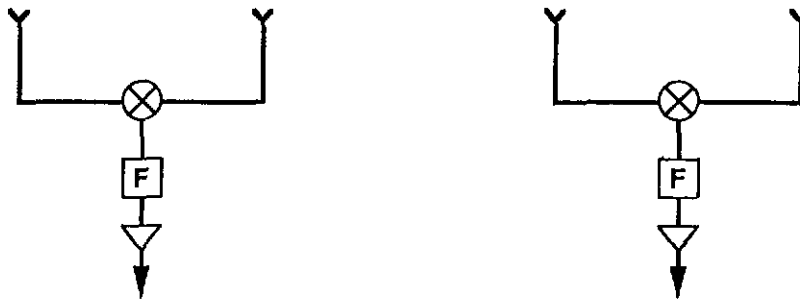
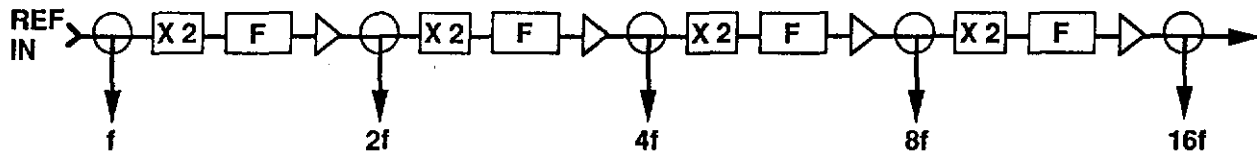

Figure 9. UNIVERSAL LOW NOISE FREQUENCY MULTIPLIER



$$X 19 = 16f + (f + 2f)$$

$$X 23 = 16f + (8f - f)$$

$$X 5 = 4f + f$$