

THE COAST ARTILLERY JOURNAL

Volume 68

APRIL, 1928

Number 4

The Military Policy of the Critical Period

By EDGAR B. WESLEY

THE period between the Revolutionary War and the inauguration of Washington has received slight attention from historians.¹ National affairs were unsettled; the states quarrelled; the Articles of Confederation were inadequate; the government was hopelessly weak; and the military strength of the new union was contemptible. These facts have caused a general neglect of the period. The historian dwells upon the glories of the Revolution and hastens glibly over the succeeding interval to expand upon the constitution. No nation likes to contemplate its failures, and it is no surprise that a copy of the Articles of Confederation is seldom, if ever, found in a textbook. The Articles were not the only failure of the period. In truth, it was the low-water mark of our national history. This is peculiarly true of its military history, but all beginnings are interesting, and if an examination of the military policy of the period serves no other purpose, it will at least afford, by way of contrast, a basis for national satisfaction. It is important, however, for the lack of a military policy was one of the direct causes of the formation of the constitution. The necessity of having an army was one of the painful lessons of the period, and since the Articles would not allow one, they had to be supplanted.

The legal basis of the military policy of the Critical Period is to be found in the Articles of Confederation. Whatever policy was evolved was necessarily dependent upon their provisions. Article II provided for the "common defense" and bound the states "to assist each other against all force offered to, or attacks made upon them or any of them." Article VI prohibited the states from treating with foreign nations, making alliances among themselves, or maintaining an army or navy in time of peace without the consent of Congress. It required the states to maintain militia and to provide war supplies. Article IX gave Congress the "power of determining on peace and war," of "managing all affairs with the Indians," of building a navy, and of

1. No adequate history of the Critical Period has been written. Fiske's colorful narrative takes slight account of anything except political affairs. The most detailed account is perhaps that found in Hildreth's general work.

Report Documentation Page

Form Approved
OMB No. 0704-0188

Public reporting burden for the collection of information is estimated to average 1 hour per response, including the time for reviewing instructions, searching existing data sources, gathering and maintaining the data needed, and completing and reviewing the collection of information. Send comments regarding this burden estimate or any other aspect of this collection of information, including suggestions for reducing this burden, to Washington Headquarters Services, Directorate for Information Operations and Reports, 1215 Jefferson Davis Highway, Suite 1204, Arlington VA 22202-4302. Respondents should be aware that notwithstanding any other provision of law, no person shall be subject to a penalty for failing to comply with a collection of information if it does not display a currently valid OMB control number.

1. REPORT DATE APR 1928		2. REPORT TYPE		3. DATES COVERED 00-00-1928 to 00-00-1928	
4. TITLE AND SUBTITLE The Coast Artillery Journal. Volume 68, Number 4, April 1928				5a. CONTRACT NUMBER	
				5b. GRANT NUMBER	
				5c. PROGRAM ELEMENT NUMBER	
6. AUTHOR(S)				5d. PROJECT NUMBER	
				5e. TASK NUMBER	
				5f. WORK UNIT NUMBER	
7. PERFORMING ORGANIZATION NAME(S) AND ADDRESS(ES) Coast Artillery Training School, Coast Artillery Journal, Fort Monroe, VA, 23651				8. PERFORMING ORGANIZATION REPORT NUMBER	
9. SPONSORING/MONITORING AGENCY NAME(S) AND ADDRESS(ES)				10. SPONSOR/MONITOR'S ACRONYM(S)	
				11. SPONSOR/MONITOR'S REPORT NUMBER(S)	
12. DISTRIBUTION/AVAILABILITY STATEMENT Approved for public release; distribution unlimited					
13. SUPPLEMENTARY NOTES					
14. ABSTRACT					
15. SUBJECT TERMS					
16. SECURITY CLASSIFICATION OF:			17. LIMITATION OF ABSTRACT	18. NUMBER OF PAGES	19a. NAME OF RESPONSIBLE PERSON
a. REPORT	b. ABSTRACT	c. THIS PAGE			
unclassified	unclassified	unclassified	Same as Report (SAR)	100	

determining the number of troops to be furnished by each state. Congress could not raise an army directly, for its requisitions were made to the states, and the legislatures had to approve of the call before it became effective. The men were raised, armed, clothed, equipped, and their regimental officers selected by the states. The general government selected the superior officers and paid the costs. No provisions were made for compelling the states to keep up their militia, to provide war supplies, to furnish their quota, or to cooperate even in case of war. Although many provisions seem to indicate that Congress had great power in defensive matters, the efficacy of such provisions was destroyed by the lack of the power to enforce what the states had constitutionally conceded.

The Revolutionary War enabled the Continental Congress to assume great powers even though it lacked any legal status. The necessity of establishing a military policy compelled it to become a national governing body for the duration of the war. With the adoption of the Articles of Confederation on March 1, 1781, the status of Congress was materially altered. Whereas before that date it had been an extra-legal body with great powers, it then became a legally constituted body with very definite and limited powers. War produced a military policy which was theoretically invalid after the adoption of the Articles, but practically there was no change since the war ended so soon afterwards.² Not until after the treaty of peace was Congress free to alter the defense policy. From a military viewpoint the adoption of the Articles was without immediate effect, and the natural policy of the new government did not begin until 1783.

The preliminary treaty which ended the Revolutionary War was signed at Versailles on November 30, 1782, and an armistice was proclaimed on January 20, 1783.³ The end of the war brought problems almost as difficult as the war itself. The disbanding of the army, the pacification of the Indians, the defense of the frontiers, and the maintenance of an international status were the major aspects of the defense problems. Of these the problem of disbanding the army was most pressing.

With the prospect of peace, the reaction against war and the revival of the old prejudice against armies became very marked. Failing to distinguish between a preliminary and a definitive treaty, many soldiers considered that the war was over and chafed at the delay of Congress in dismissing them. Even Congress was affected by the period of com-

2. Upton (*Military Policy of the United States*, 30-32. 59-60) mistakenly says that the Articles went into effect in July, 1778. He then proceeds to blame them for the military mistakes of the war after that date. He attributes the lack of cooperation by the states and the "wretched condition of the Army" to the weakness of the Articles. This invalidates many of his conclusions.

3. Ma'hoy. *Treaties*, I. 580-585.

parative inactivity following the siege of Yorktown and took some steps to reduce the size and expense of the army. A resolution of August 7, 1782, directed a reorganization of the army in order to release some of the officers. This measure became effective January 1, 1783.⁴ On January 30, 1783, Washington wrote to Congress for instructions in regard to preparations for future campaigns. He pointed out the wisdom of being prepared in case the negotiations should fail.⁵ Congress, confident of the success of the negotiations, resolved that no preparations were necessary and instructed the president to inform Washington of the status of the negotiations.⁶

On April 4 Congress ordered the states to suspend enlistments for the national army, and on April 7 it instructed the Secretary at War, in concert with the Commander-in-Chief, to report as speedily as possible upon measures for reducing military expenses.⁷ On April 11 it issued a proclamation ordering the cessation of hostilities.⁸ This proclamation was read to the army on April 19, the eighth anniversary of the Battle of Lexington.

The beginning of the disbandment of the army dates from April 23. On that day Congress decreed that the enlistments of the men who were to serve during the war did not expire until the signing of a definitive treaty of peace, but the Commander-in-Chief was directed to use his discretion in granting "furloughs and discharges." On the following day a resolution directed the Secretary at War to remove the Virginia, Maryland, and Pennsylvania troops, which were then in the South under General Greene, to convenient places within their respective states.¹⁰ On May 23 a resolution to disband the army was defeated, but on May 26 Congress directed the Commander-in-Chief to grant furloughs to soldiers, noncommissioned officers, and a proportionate number of officers who were enlisted to serve during the war, their discharge to become effective upon the signing of a definitive treaty of peace. The men were to be allowed their arms and were to be conducted to their respective homes. Another resolution, on the same day, directed the Commander of the Southern army to grant similar furloughs to the troops from North Carolina who were enlisted to serve for eighteen months.¹¹ On June 11 Congress directed the Secretary at War to sign the furloughs of the troops from Pennsylvania, Delaware, Maryland, and Virginia, and on August 9 he was directed to grant furloughs to the troops in Maryland and Virginia. On September

4. *Journals of Congress*, IV, 57-58.

5. Washington, *Writings*, (Sparks' ed.) VIII, 376-380.

6. *Secret Journals of Congress*, IV, 184, 185.

7. *Journals of Congress*, IV, 184, 185.

8. *Ibid.*, IV, 186-187.

9. *Ibid.*, IV, 193.

10. *Ibid.*, IV, 194.

11. *Ibid.*, IV, 222-224.

26 Congress extended the privilege of securing furloughs to such of the general, medical, and staff officers, and officers of the engineers as the Commander-in-Chief thought could be spared.¹²

In a letter to Congress on September 19 Washington called attention to the number of soldiers on furlough. "I call them discharges, because it is in this light furloughs have all along been considered." He said the question of saving money by discharging the soldiers must be balanced with the danger of premature discharges.¹³ Congress decided to save the money, and accordingly, on October 18, issued a proclamation disbanding the army to take effect November 3. All who were on furloughs were included, and all who were engaged to serve during the war were "absolutely discharged by virtue of this our proclamation."¹⁴ The army of the Northern Department was disbanded on November 5 and that of the Southern Department on November 15.¹⁵ On October 29 Congress extended the discharges to "all troops in the service of the United States who are now in Pennsylvania or to the southward thereof, except the garrison at Fort Pitt."¹⁶

The men thus far discharged were those who had engaged to serve for the duration of the war and those in or south of Pennsylvania. Those remaining in service had enlisted for definite periods. A motion to discharge all but five hundred of the federal army after the evacuation of New York was defeated on November 4.¹⁷ On December 21 Washington wrote to Congress that he had ordered Major General Knox to reduce the whole of the troops to one battalion of five hundred infantry and one hundred artillery.¹⁸ On January 3, 1784, Knox wrote to Washington that the troops had been discharged except one regiment of five hundred and one hundred and twenty men in the artillery whose terms had not expired.¹⁹ So the army consisted of six hundred and twenty men. These were stationed at Springfield, New York, Fort Schuyler, and the lake posts.²⁰ On January 8 Congress, in refusing the application of a captain for promotion, pointed out that the definitive treaty had been signed and "nearly the army discharged."²¹ However, there was a sufficient force left for Congress to resolve on January 29 that regular reports "of the troops retained in service" should be made.²² On June 2 Congress directed the commanding officer to discharge all troops in the service of the United States except twenty-five

12. *Ibid.*, IV, 228, 252, 279.

13. Washington, *Writings* (Ford ed.) X, 317. The entire letter has apparently not been preserved. It is also referred to in *Journals of Congress*, IV, 299.

14. *Journals of Congress*, IV, 299.

15. *American State Papers, Military Affairs*, I, 19.

16. *Journals of Congress*, IV, 304.

17. *Ibid.*, IV, 316.

18. Washington, *Writings* (Sparks' ed.) VIII, 502-503.

19. Drake, *Life of Knox*, 86.

20. Brooks, *Henry Knox*, 186-187.

21. *Journals of Congress*, IV, 321-322.

22. *Ibid.*, IV, 332.

privates to guard the stores at Fort Pitt and fifty-five to guard the stores at West Point and other places. The troops which had been enlisted on the best terms were those to be retained.²³ Thus the army was reduced to eighty men and officers, with no officer above the rank of captain. This action was the low-water mark in the history of the army, which cannot correctly be called an army at all, for the eighty men were specifically designated as guards of the public stores.

There was, however, some opposition to the policy of complete disarmament, for on May 25, preceding the discharge of the last of the troops, a resolution to raise an army of four hundred and fifty men for three years was debated, but it, with an amendment changing the number to 896, was defeated.²⁴ The opposition to the motion to raise troops was based partly on constitutional grounds. Elbridge Gerry, of Massachusetts, pointed out that there was a difference of opinion as to the power of Congress to raise an army in time of peace and that no such step should be taken until the delegates had consulted their constituents. He said that the power to raise a small force for a short time would logically lead to "an unlimited power to extend their requisitions," and he struck a familiar and oft-repeated note, even to the very phraseology, when he said: ". . . standing armies in time of peace are inconsistent with the principles of republican governments, dangerous to the liberties of a free people, and generally converted into destructive engines for establishing despotism." He said that the plan of the Confederation which required the states to "keep up a well-regulated and disciplined militia" should be the basis of defense. Congress adopted Gerry's main contention and voted that "recommendations in lieu of requisitions shall be sent to the several states for raising the troops."²⁵

On June 3, the day following the discharge of the last of the regular troops, Congress voted to raise an army of seven hundred men for one year for the purpose of occupying the Northwest posts, protecting the frontiers, and guarding the public stores. The resolution carefully "recommended to the states" that they furnish from their militia the desired troops as follows: Connecticut, 165; New York, 165; New Jersey, 110; and Pennsylvania, 260. The states were to appoint the officers, the office of lieutenant colonel, who was to be commandant, being awarded to Pennsylvania.²⁶

To oversee the army, provide supplies, make reports, and carry out the orders of Congress a reorganization of the War Department was found necessary. General Lincoln, who held the office of Secretary

23. *Ibid.*, IV, 337-338.

24. *Ibid.*, IV, 412-413.

25. *Ibid.*, IV, 413-414.

26. *Ibid.*, IV, 440-441. Upton (*Military Policy*, 69.) mistakes the resolution as originally introduced for the law which was actually enacted.

at War during the latter part of the war, resigned on October 29, 1783. Following his resignation the duties of the office were performed by Joseph Carlton who was designated as Secretary in the War Office.²⁸ On May 29, 1782, Congress instructed a committee of the states "to prepare and report to Congress, an ordinance for making the necessary arrangements of the treasury, and for more particularly defining the powers of the board of treasury, and also to revise the institution of the office for foreign affairs, and of the war office, and to report such alterations as they may judge necessary."²⁹ On December 8 Congress voted to postpone the election of a Secretary at War until the ordinance for regulating the duties of the office could be prepared.³⁰ On January 27, 1785, Congress passed an ordinance defining the powers and duties of the Secretary at War. He was to inspect the troops, arms, ammunition, ordnance, and supplies; keep returns of all the forces; make estimates of necessary troops, supplies, and equipment; carry into effect all resolutions of Congress pertaining to the army; direct the operation of the troops; sign all commissions of military officers; keep records and make semi-annual reports; and make annual visits to magazines and storehouses. He had the power to appoint and remove all persons employed under him.³¹

Before the definite revival of the office of Secretary at War, Major General Henry Knox, who later succeeded Washington as commander-in-chief, suggested the creation of such an office. Writing to Washington on September 17, 1783, he said that he would be willing to serve as a minister of war or master-general of ordnance.³² On November 2 Washington wrote to Knox that several members of Congress were favorable to combining the offices of Secretary at War and Master of Ordnance, and he assured Knox of his best efforts in securing the position for him in case it was created.³³ On March 4, 1785, Congress placed the salary of the Secretary at War at \$2450 and on the eighth elected Knox to the position.³⁴

The army of seven hundred had been obtained for one year only, and in order to provide for the national defense after the expiration of their enlistments Congress debated and passed on April 1, 7, and 12 a resolution to call upon the states to furnish seven hundred men for three years. The state quota basis was the same as in the previous resolution. They were to be organized as one regiment of eight companies of infantry and two of artillery.³⁵

27. *Journals of Congress*, IV, 304-305.

28. *Ibid.*, IV, 315, 332, 441, 446, 452, 463, 488.

29. *Ibid.*, IV, 423.

30. *Ibid.*, IV, 452.

31. *Ibid.*, IV, 462-463.

32. Drake. *Life of Knox*, 85.

33. *Ibid.*, 86.

34. *Ibid.*, 89-90; *Journals of Congress*, IV, 477-478.

35. *Journals of Congress*, IV, 493, 496, 497.

The strength of the Confederacy and the wisdom of the defense policy were tested by Shay's Rebellion which broke out in Massachusetts in 1786. Since most of the army was on the northwestern frontier, the nation found itself without means to protect its own arsenal at Springfield. In October, Secretary Knox made a hurried visit to Boston and Springfield and secured Governor Bowdoin's promise that the state militia would protect the arsenal.³⁶ He returned to New York where he secured, on October 20, the unanimous approval of a bill to enlist 1340 men for three years, thus raising the army to 2040. The men were to be raised from the states as follows: New Hampshire, 260; Massachusetts, 660; Rhode Island, 120; Connecticut, 180; Maryland, 60. The resolution urged the governors to use their utmost energy to fill the ranks immediately.³⁷ The Journals refer to alarming reports from all along the frontiers, but the real reason was well understood by the delegates, and the Secret Journals state that Congress would not hazard the perilous step of enlisting men whose fidelity must in some degree depend upon their being paid, had they not the fullest assurance and confidence that money holders in Massachusetts and the other states would subscribe to the loans authorized on the same day.³⁸ Knox, in a letter to Washington on October 23, refers to Indian hostility, but he also said that the measure would "strengthen the principles of government" and added that "the idea of strengthening government" was "confidential." He said that Massachusetts needed "the greatest assistance." When the insurrectionists threatened the arsenal General Shepard asked permission to use its stores, and on January 27, 1787, Knox acceded to the request.³⁹ The Massachusetts militia soon scattered their opponents, and the crisis which spread such terror subsided. The effect upon the military policy was negligible, but its political effect was great.

In accordance with the resolution some Connecticut troops were raised and stationed at Springfield, and some Massachusetts troops were stationed at Boston. On April 9, 1787, Congress voted that the Massachusetts troops be formed into two companies of artillery and that they should replace the Connecticut troops. The resolution ordered the discharge of the Connecticut troops and all others who had been raised under the act of October 20, 1786, and the suspension of further enlistments.⁴⁰ Thus, after Shay's Rebellion the army consisted of the

36. Drake, *Life of Knox*, 90-93; Channing, *History of the United States*, III, 486.

37. *Journals of Congress*, IV, 714. Upton (*Military Policy*, 70) gives no indication that he knew the real purpose of the proposed increase, but seems to accept it as a genuine movement toward augmenting the regular army.

38. *Secret Journals of Congress*, I, 267-268.

39. Drake, *Life of Knox*, 90-93.

40. *Journals of Congress*, IV, 733. Upton (*Military Policy*, 70) overlooked the fact that other troops than the Massachusetts companies were raised under the act of October 20, 1786.

seven hundred men enlisted in 1785 for three years and the two companies of Massachusetts artillery raised under the act of October 20, 1786.

On October 3, 1787, Congress voted to continue the army of seven hundred and the two companies of Massachusetts artillery for three years on the same quota basis and urged the reenlistment of the men on the frontiers, both because of their experience and in order to save the expense of transporting new levies.⁴¹ The army thus numbered 840. No additional provisions for increasing the army were made under the Articles of Confederation. According to a committee report of October 2, 1788, the army consisted of 679 men, 345 of whom were on the Ohio, 250 enlisted and ready to march west, thirteen at West Point, and seventy-one divided between Springfield and West Point. The two Massachusetts regiments which were raised to quell Shays's Rebellion had been reduced to seventy-one. Desertions were caused by irregular pay and by the fact that the troops raised elsewhere under the same act had been discharged. The committee thought that the time which the men of the two companies had yet to serve was too short to justify filling up the ranks and marching them to the frontier. It also pointed out that by combining the companies and eliminating a captain and two lieutenants \$1380 a year could be saved.⁴² Thus, with one minor exception, the army through the Critical Period numbered a possible seven hundred, and was actually somewhat short of that number most of the time.

The small establishment of the national army made it impossible for it to do more than police duty. It acted as a nucleus for the formation of an effective force, afforded training for a small group, and had a moral effect upon the Indians, but whenever danger actually developed Congress was forced to call upon the states for their militia.⁴³

So feeble was the army that some of the states, taking advantage of their rights under the Articles, asked Congress for permission to maintain a state force. On October 3, 1783, Virginia secured authority to raise a force of twenty-five men and officers and to keep up at its own expense a navy not to exceed two vessels of fourteen guns and seventy-five men each.⁴⁴ On May 13, 1784, New York renewed its request for authority to maintain an army of five hundred to protect the frontiers. The request showed great impatience and manifested an inclination to

41. *Journals of Congress*, IV, 785-786.

42. *Ibid.*, IV, 874-879.

43. Examples: July 21, 1787, call on Virginia for 1000 Kentucky militia; October 26, 1787, call on Southern states for 200; August 12, 1788, call on Virginia for 1000 and Pennsylvania for 500. *Journals of Congress*, IV, 762, 804, 847. Others could be cited.

44. *Journals of Congress*, IV, 282.

proceed to raise the troops without the consent of Congress if it were not granted.⁴⁵

The securing of arms and ammunition was not a serious problem during the Critical Period, for the ample supplies left over from the Revolution more than met the requirements of the succeeding period. On April 26, 1782, Congress instructed the Secretary at War to establish magazines at New London, Virginia, and at other places, and on June 12, 1783, it directed that the Virginia magazine should be placed above the falls of the James.⁴⁶ On January 29, 1784, Congress directed the Secretary in the War Office to secure exact returns of all ammunition and supplies for the troops,⁴⁷ and on September 6, 1785, it directed the Secretary at War to report the location and description of all cannon, small arms, supplies, and all property charged to the War Department, and thereafter to make semi-annual returns of such material.⁴⁸

The committee report of October 2, 1788, pointed out many facts about the Ordnance Department. There were arsenals at Springfield, West Point, and Philadelphia, but the buildings for storing the arms were unsatisfactory, and the committee said that the erection of suitable arsenals was an object that required attention. In addition to the principal arsenals, supplies were stored at Providence, Fort Herkimer on the Mohawk, New London, Manchester, Virginia, Charleston, South Carolina, and Carlisle, Pennsylvania, though the last two were to be abandoned soon. The committee recommended the purchase of West Point in accordance with a former resolution on August 3, 1786,⁴⁹ but the purchase had been delayed because of the absence of the owner of the property.⁵⁰

The supplying and provisioning of the army was a difficult task because of the poverty-stricken condition of the nation. The Quartermaster General's Office was abolished on July 25, 1785 and his duties devolved upon the Secretary at War.⁵¹ Clothing and rations were furnished by contract, and tents and many minor supplies were purchased by the Secretary. The price for provisions increased with the distance westward from Fort Pitt, and the quality of the goods and the delays of the service were often condemned by the soldiers and officers. The standard of equipment may be judged by the fact that

45. *Ibid.*, IV, 403, 404, 425.

46. *Journals of Congress*, IV, 228. No mention is made of the first resolution under entry of April 26, 1782, but it is referred to in the entry of June 12, 1783.

47. *Ibid.*, IV, 332.

48. *Ibid.*, IV, 567.

49. *Ibid.*, IV, 676.

50. *Ibid.*, IV, 877-878.

51. *Journals of Congress*, IV, 553.

the committee reported on October 2, 1788, that the troops enlisted in 1785 "have already received two complete suits."⁵²

An account of the activity of the army would be equivalent to a history of frontier defense, for that was their only service during the Critical Period. The niggardly pay, the hard service, the miserly equipment, and the constant interference of Congress nullified any plans for a real military policy. Although Lieutenant Colonel Josiah Harmer was the commander of the army,⁵³ it was subject to the orders of the Indian commissioners,⁵⁴ and one of its principal duties was to expel squatters on Indian lands.⁵⁵ The military rules adopted by Congress on May 31, 1786, forbade the execution of a soldier or the removal of an officer without the approval of Congress.⁵⁶ The establishment of posts and the disposal of the troops were entirely in the hands of Congress, and the Commander-in-Chief was assigned the task of negotiating Indian treaties.⁵⁷

A review of the military policy of the Critical Period has shown its utter inadequacy. The states could nullify the proposals of Congress, and Congress meddled with details. The Indians on the frontier and Shay's Rebellion in Massachusetts proved the feebleness of the policy. Although the constitution has prolonged some of the provisions of the Articles, it at least made a national military policy a possibility.

52. *Ibid.*, IV, 875.

53. He was appointed on August 12, 1784. Heitman, *Register of United States Army*, I, 591.

54. *Journals of Congress*, IV, 487, 539, 542.

55. *Ibid.*, IV, 538; Smith, ed., *St. Clair Papers*, II, 3, 6.

56. *Journals of Congress*, IV, 649-651.

57. *Ibid.*, IV, 655, 761-762.

MAXIM XVII

In a war of march and maneuver, if you would avoid a battle with a superior army, it is necessary to entrench every night, and occupy a good defensive position. Those natural positions which are ordinarily met with are not sufficient to protect an army against superior numbers without recourse to art.—Napoleon's Maxims of War.

Much About Little

By LIEUT. PHILIP SCHWARTZ, O. D.

Honorable Mention, Annual Essay Contest

EDITOR'S NOTE: For the benefit of those officers who have not made a special study of gunnery, the author of this article attempts to explain in non-mathematical and non-technical language the influence of the rotation of the earth upon the projectile in flight. The subject has been reduced to the simplest of terms, and the statements are general rather than exact. JOURNAL readers who find themselves unable to subscribe to all the statements contained in the article should note that the author states that the explanation is not mathematically adequate.

FROM time to time the question of the effect of the earth's rotation on the point of fall of a projectile comes up. The subject usually appears to be a mysterious one when first mentioned; after a limited amount of study the complications involved become noticeable, and after an extended study the interested person is usually willing to admit that the mathematical method of determination is correct. If, after his investigation, he attempts to explain what he has studied, he usually accomplishes little, even if he omits the mathematical symbols and uses words instead.

In the November, 1927, number of the COAST ARTILLERY JOURNAL, Roger Sherman Hoar, Major Ord. Res. (Formerly Captain, C. A. C.), in the leading article, deals with the inaccuracies in the present approved rotation of earth explanations. He points out that the latest Training Regulations on Gunnery for Heavy Artillery give an explanation which is not correct. He attempts to set down and "evolve a set of physical explanations which will reduce to the Moulton formulas term by term." The net result of his attempt is an article which, although highly commendable in the proper place, is probably classified as "Greek letter mathematics" by most of the readers of the JOURNAL. From a first reading, that mythical individual, "the average reader," will gather that there is something wrong in the current explanations, but he will probably not understand what and where the error is supposed to be. He will probably conclude that he does not care whether the explanation is right or wrong. He will say that the correction for rotation of earth is exceedingly small and is used only in cases where other corrections of much greater magnitude must be neglected. He will say further that, even if he wished to make the correction during firing, he could not do so because the range-correction board does not have enough pointers on its ruler to allow for making this correction.

Section III of T. R. 435-280, *Gunnery for Heavy Artillery*, consists of nineteen pages devoted to an explanation of Firing Tables. Of these

nineteen pages, three and one-half are devoted to an explanation of the effect of the earth's rotation. Every Coast Artillery officer will therefore, at some time in his career, be interested in the subject, either from the point of view of the student, the instructor, or both. If the explanation now contained in the T. R. is not accurate or sufficient, the average Coast Artillery officer will want it corrected so that he will have no unnecessary difficulty when he reaches it in the course of his study or explanation. The average student or instructor would be satisfied with a minimum amount of the detailed explanation of how the effect occurs. The *fait accompli* is what interests him; the method of accomplishment, being highly theoretical in explanation, is of secondary importance.

Section II paragraph 18 of T. R. 435-280 deals with the correction for the effect of wind on the point of fall of a projectile, the discussion being begun and ended in less than one page. Wind corrections are among the most important, and have been the subject of much discussion ever since corrections to artillery fire were first applied. The practical student's impression of the relative value of the paragraphs on rotation of earth and wind would probably be expressed satisfactorily by saying that more wind and less rotation would help the section on firing tables.

Notwithstanding the apparent inaccuracies in the T. R. explanation of rotation, the writer has been assured by more than one graduate of the Battery Officer's course that the explanation is clear and understandable. There are other curious stories about the subject. One story is to the effect that two officers in the A. E. F. were asked to compute the amount of the effect of the rotation of the earth, one officer reporting a given amount, the other officer reporting the same amount but with opposite sign. Another story is to the effect that the British claim that in one of their naval battles their poor shooting was accounted for by the difference in rotation effects in the northern and southern hemispheres. Another curious condition, which can be verified by examination of the firing tables, relates to the fact that the range correction for rotation is greatest at the equator, whereas the deflection correction is greatest at the poles. To the casual student it would appear that both range and deflection corrections should be greatest at the equator.

It is of interest to note that neither the mathematics of the subject nor the firing table values have been questioned. It is only the non-mathematical attempts to explain the subject which are in doubt. Another attempt in the form of two alternative explanations is presented

herein. Neither explanation is considered to be mathematically complete, but either is sufficient for artillery needs.

EXPLANATION "A"

The effect of rotation of the earth on the point of fall of a projectile fired from a gun may be visualized by following the step by step explanation given below.



FIG. 1

Step I: Assume that the earth's surface is a motionless plane (Fig. 1) having a vacuum above the surface. The range AB of any projectile will depend only on the angle of departure and the initial velocity of the projectile.



FIG. 2

Step II: Assume that the earth is a motionless sphere (Fig. 2) having a vacuum above its surface. A projectile fired with the same initial velocity and angle of departure as in Step I will have a greater range by an amount B_1E_1 , which will depend on the angle of fall and the radius of the earth. This increase is usually called a curvature of earth effect.



FIG. 3

Step III: Assume that the earth's surface is a plane (Fig. 3) moving with constant velocity in a plane parallel to its surface and having a vacuum above it. The range attained by a projectile fired under the same conditions as in Step I will be greater than AB by an amount BF which will depend on the speed and direction of the earth's surface, the time of flight, and the direction of fire. There will also be a deflection effect which will depend on the same factors as the range difference.



FIG. 4

Step IV: Assume that the earth is a sphere rotating about one of its axes (Fig. 4) and having a vacuum above its surface. A projectile fired as in Step I, will have an increase in range B_1E_1 due to the curvature effect explained in Step II. In addition, there will be a difference in range and deflection similar to that described in Step III. This range difference E_1F_1 will depend on the speed of rotation, the radius, and the mass of the earth, the characteristics of the trajectory, the azimuth of fire, and the latitude of the gun. (By characteristics are meant inclination and remaining velocity as well as coordinates, of all points of the trajectory from the initial to the final points.) The total range increase will be B_1F_1 .

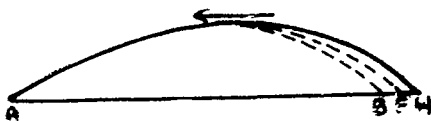

FIG. 5

Step V: Assume that the earth's surface is a plane (Fig. 5) moving with constant velocity in a plane parallel to the earth's surface, having air above it. This case is similar to that described in Step III, except that, due to the presence of air, retardation of the projectile must be considered, as well as the slight amount by which the rotating mass of air drags the projectile along with itself. The total range increase over AB will be $BF+FH=BH$. The deflection change is calculated in a similar manner.



FIG. 6

Step VI: Assume that the earth is a sphere (Fig. 6) having air above its surface and rotating about one of its axes. The range of a projectile will be calculated in a manner similar to that in Step IV, except that, as in Step V, retardation and the drag of the air must be considered. This step is the final one in which are considered the conditions actually

existing. The total range increase over AB will be $B_1E_1 + E_1F_1 + F_1H_1 = B_1H_1$. However, it should be noted here that B_1E_1 is ordinarily omitted from the rotation effect because it is considered separately in the curvature effect discussion. The net rotation range effect is therefore E_1H_1 . The net deflection effect of rotation is calculated in a similar manner, the curvature effect being of no importance in considering the deflection.

EXPLANATION "B"

Suppose an observer is at the North Pole of the rotating earth along

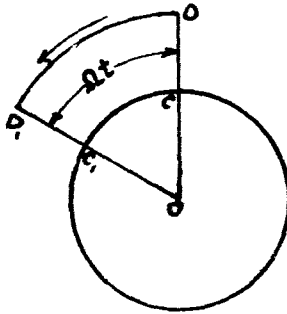

FIG. 7

the prolongation of the axis O , as in Fig. 7. Let the circle OCC_1 represent any section of the earth perpendicular to the axis. On the circle there is a point C . Above this point C on the prolongation of the line OC there is a particle of air D at a greater distance from the axis of the earth than C by the amount CD . Let us assume that the air above the earth rotates with the earth as a unit so that all particles of the air have the same angular velocity about the earth's axis as all parts of the earth. Then particle D will always be on the prolongation of the line OC unless disturbed by some outside force not considered hitherto. Particle D must travel around the circumference of a circle which is larger than the one on whose circumference point C travels, and in the same time. Since it covers a greater distance in the same time, the linear speed of particle D (any particle above the surface of the earth), must be greater than the linear speed of point C (any point on the surface of the earth). For example, during any time t , the earth, rotating with angular speed Ω , passes through the angle Ωt . In the time t the point C moves to C_1 and the particle D to D_1 . It can easily be seen that DD_1 is longer than CC_1 and therefore the speed of particle D in its orbit must be greater than that of point C . Similarly, it may

be shown that any particle above the surface of the earth has a greater linear speed than any point on the surface of the earth.

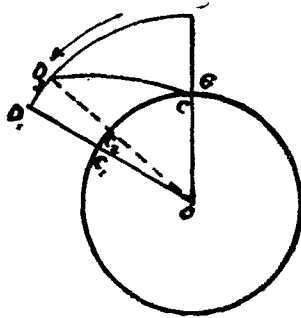

FIG. 8

Let us place a gun G at C as in Fig. 8 and fire a projectile from it at an angle of departure of 90° directly toward the particle D . When the projectile leaves the surface of the earth it has a linear velocity parallel to the surface of the earth at C equal to the tangential velocity of point C . Being only a very thin medium, the air does not carry the projectile with it as it would if it were more of a solid medium. As the projectile goes higher and higher it meets particles of air which have increasingly greater linear speed in the circle corresponding to their altitudes than its own, the tangential speed of point C . The projectile therefore finds that it is being gradually left farther and farther behind the particles of air which were originally on the line OCD . When the projectile in time t has reached the altitude of the particle D , which due to the rotation of the air with the earth has moved to the position D_1 , it is found at the point D_2 . The point on the surface of the earth corresponding to D_2 is C_2 , and to D_1 is C_1 . Since the point C in time t has moved to C_1 , whereas the projectile has reached a particle of air corresponding to point C_2 , the projectile is said to "lag" by the distance C_1C_2 . When the projectile finally falls to the earth the amount of lag is a maximum.

If the projectile is fired at an angle of departure differing from 90° , the amount of lag will not be so great. If the azimuth of fire is along a meridian of longitude, the lag will show itself in the deflection effect. If the azimuth of fire is along a parallel of latitude, the lag effect will be entirely in range. If the firing is at any azimuth not along a meridian or a parallel, the lag will affect both range and deflection. If the gun is at a pole there can be no range effect, the lag effect being only in deflection.

It is ordinarily possible to compute a component of the velocity of the projectile in a plane which is at right angles to the axis of rotation of the earth. This component tends to take the projectile along the equivalent of an arc of a circle which has its center on the axis of the earth. As a result of this circular motion, the projectile is acted upon by the centrifugal force which is always associated with motion in a circle. The direction of this force is such as to change the gravitational force. Due to the change in the angular speed of this circular motion caused by the rotating earth, the value of the acceleration of gravity g , which was used in the standard trajectory computation, is subject to a correction. The effect of this correction in g is incorporated in the calculation for the effect of the earth's rotation.

Resistance of the air is neglected in the above discussion. However; for exact calculation it is necessary to take into account the effect of the air on the rotation of earth effect. At the high speeds at which projectiles are usually fired, the number of particles of air struck by the projectile in a unit of time is very large. For such speeds the action of the air on the projectile is equal in amount to the effect of a much denser medium on a projectile moving at a much lower velocity. Therefore, one of the assumptions made previously in this discussion, that the air does not drag the projectile with it in its motion of rotation, must be modified before exact calculations are made for the effect of the earth's rotation on a projectile moving through its atmosphere.

The total effect of the earth's rotation is the sum of the effects of "lag," change in centrifugal acceleration, and change in the air's retardation.

MAXIM XVIII

A general of ordinary talent occupying a bad position, and surprised by a superior force, seeks his safety in retreat; but a great captain supplies all deficiencies by his courage, and marches boldly to meet the attack. By this means he disconcerts his adversary; and if the latter shows any irresolution in his movements, a skillful leader, profiting by his indecision, may even hope for victory, or at least employ the day in maneuvering—at night he entrenches himself, or falls back to a better position. By this determined conduct he maintains the honor of his arms, the first essential to all military superiority.—Napoleon's Maxims of War.

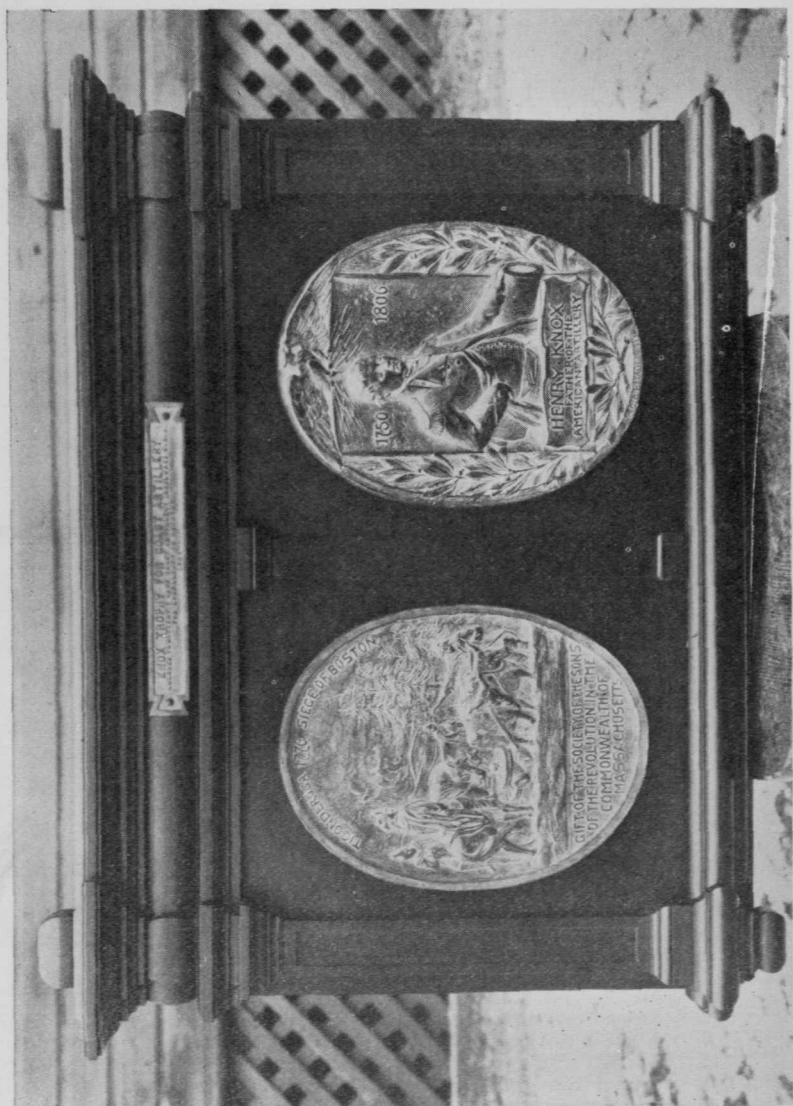

THE KNOX TROPHY

The Knox Gunnery Trophy

ON January 18, 1928, the War Department made the following announcement: "The Chief of Coast Artillery announces that Battery E, 52nd Coast Artillery (Ry.), Fort Eustis, Virginia, commanded by Captain D. B. Greenwood, is the winner for the year 1927 of the Knox Trophy donated by the Society of the Sons of the Revolution in the Commonwealth of Massachusetts to that battery of Coast Artillery which attained the best results in target practice and gunnery."

The purpose of the society in making this donation is expressed in the certificate which accompanies the trophy and which reads in part as follows:

The Society of the Sons of the Revolution in the Commonwealth of Massachusetts, desiring to make the early and inspiring traditions of the Army and Navy tributary to the present efficiency of the service, has prepared a series of trophies to be given for excellence in gunnery and in artillery. The trophies bear the name of Henry Knox, the most resourceful soldier of the Revolution, who won early distinction and rapid promotion under Washington for skill in the handling of heavy ordnance, and who, upon the organization of the Federal Government, became the first Secretary of War. The career of General Knox has been recalled not only for its fitness to the purpose for which these trophies are to be presented, but with still more reason, because of those professional and personal qualities which made him so conspicuous an example of the soldier and the patriot—supreme devotion to the country, a controlling sense of honor, and unflinching courage and hopefulness in times of adversity. The Knox trophies are designed to express the reliance which the country must place upon the technical skill of those who stand for its defense, and for its part in maintaining the peace of the world. They are given in full recognition of the fact that no nation can be safe or useful which does not keep pace with the advance of science as applied to the arts of war. In this advance, the supreme test of efficiency is accuracy in the science of gunnery. Every shot which finds its mark adds to the security of the nation. Hence the increasing interest, and watchful pride with which the country follows the practice of the Navy in gunnery, and of the Army and Militia in artillery.

The Commanding Officer of the winning battery was ordered to Boston, Massachusetts, on temporary duty for the purpose of receiving the trophy, which was presented at the annual banquet of the Society held at the Hotel Somerset, in the presence of a distinguished gathering. The Coast Artillery trophy was presented by General William P. Jackson, U. S. A. Trophies were also presented to the Navy and the Field Artillery, being won by the battleship *West Virginia* and by Battery

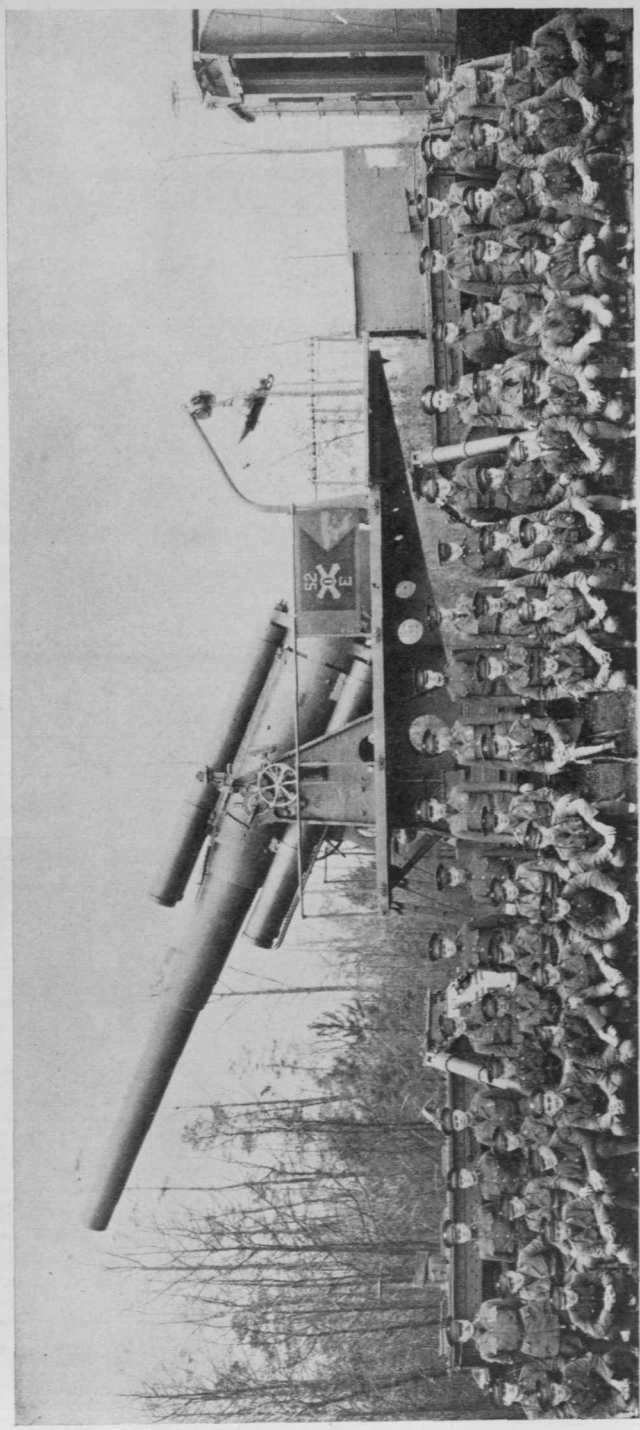

BATTERY E, 52ND COAST ARTILLERY (R.Y.), WINNER OF KING TROPHY FOR 1927

B, 82nd Field Artillery, respectively. Additional trophies were presented to outstanding Coast and Field Artillery units of the Massachusetts National Guard. The trophies presented to the Coast Artillery, the Navy, and the Field Artillery are the permanent property of the units to which they are awarded; the National Guard trophies must be won three times.

The first award of the Knox Coast Artillery Trophy was made in 1913. It has been won by the following organizations since that time:

1913—68th and 143rd Companies, C. A. C.

1914—5th Company C. A. C.

1915—122d Company C. A. C.

1916—1st Company, Fort Hancock.

1917—6th Company, Balboa.

1927—Battery E, 52nd Coast Artillery (Ry.)

The banquet being scheduled for the early part of January, 1928, insufficient time was available for the gunnery section of the Office of the Chief of Coast Artillery to consider all 1927 practices, some of which had not been fired until December of that year. The award of the trophy was therefore based on target practices fired in 1926. The award as a result of the 1927 practices will be made shortly before the next annual banquet. There is nothing secret or confidential in the manner of computing the winner of this trophy, but, since all armament from three-inch to fourteen-inch, from fixed to tractor and sound ranging units must be considered, with both air and water targets being fired upon, it is evident that the selection of the winner presents considerable difficulty. With so many different types of armament competing, a dual consideration is necessary: first, the standing of a battery among batteries of like type; second, the comparative accomplishments of each type. It might well be that a battery could stand very well in its own class, possibly might be preeminent, but if all of that class fall below the expectancy, this outstanding battery might not be entitled to classification over a battery which was only a little above the average in its class, when that whole class exceeded the expectancy. Furthermore, it must be realized that the expectancy changes each year as more data become available and as material and methods change.

During the year 1926, Battery E was commanded by Captain Donald B. Greenwood, with First Lieutenant William J. McCarthy as Executive, and Second Lieutenant Samuel H. Morrow as Range Officer. The battery fired two eight-inch railroad guns at a moving target on the James River. There being five or six miles of wooded country intervening, the target was not visible from the gun positions. The guns were laid

in direction by means of the panoramic sight and aiming rule. In the two practices fired, the following results were obtained:

	<i>First Practice</i>	<i>Second Practice</i>
Number of Record Shots	8	18
Number of Hits	4	8
Probability of hitting (Range table)	22%	22%
Per cent of hits obtained	50.0	44.4



CAPTAIN DONALD B. GREENWOOD
Commanding Battery E, 52nd Coast Artillery (Ry.)

Hits per gun per minute444	.471
Average Range	12,694	12,744
Method of Adjustment	Successive Approximations	Trial Shot

In the second practice the target was blown out of the water by a direct hit. The training methods used during the season are outlined in an article in the COAST ARTILLERY JOURNAL for February, 1927, "Some High Spots in the Training of a Railway Artillery Battery."

Coast Artillery Memorandum No. 7 not having been in effect when these practices were fired, an exact score can not be computed. As nearly as may be determined, had these practices been held under the system prescribed for the target practices to be fired in 1928, the following scores would have been made:

FIRST PRACTICE		<i>Actual</i>	<i>Allowed</i>
A Component			40.0
1st Term		23.3	
2nd Term		20.0	
B. Component		9.6	9.6
C Component		33.3	20.0
D Component		29.7	29.7
<i>a.</i> Violation of rules	0		
<i>b.</i> Wild shots	0		
<i>c.</i> Personnel errors	0		
<i>d.</i> Spotting errors	0		
<i>e.</i> Average range errors	0		
<i>f.</i> Average deflection errors3		
<i>g.</i> Average spotting errors	0		
Total deductions3		
Total Score		115.9	99.3

SECOND PRACTICE		<i>Actual</i>	<i>Allowed</i>
A Component			40.0
1st Term		22.4	
2nd Term		20.0	
B Component		14.3	10.0
C Component		200.0	20.0
D Component		28.8	28.8
<i>a.</i> Violation of rules	0		
<i>b.</i> Wild shots	1.		
<i>c.</i> Personnel errors	0		
<i>d.</i> Spotting errors	0		
<i>e.</i> Average range errors	0		
<i>f.</i> Average deflection errors2		
<i>g.</i> Average spotting errors	0		
Total deductions	1.2		
Total Score		285.5	98.8



NONCOMMISSIONED OFFICERS, BATTERY E, 52ND COAST ARTILLERY (R.V.)

Railway artillery batteries labor under disadvantages which the ordinary major-caliber battery in a Harbor Defense does not have to face. The following extracts from the First Indorsement of the Battalion Commander in forwarding the target practice reports of 1926 outlines some of the difficulties encountered.

In making a comparison of the relative merits of target practice of batteries firing railway artillery and batteries manning fixed guns in coast defense, I believe that the following disadvantages of the railway batteries should be given careful consideration.

a. Before beginning any firing problem, a battery commander of railway artillery must, with the personnel of his battery, determine the exact orientation of his guns. In some cases, although not in the present one, he must also with his battery personnel run a survey to determine the exact location of his observing stations with regard to the guns. Furthermore, in the general case, the present one included, railway guns are not so located that case two firing can be used. The orientation detail of the battery must therefore locate an aiming rule in addition to the surveys noted above. Such orientation as must be made is generally based either on data obtained from nearby geodetic points, or on data obtained by observation on Polaris or the sun, such observation being made by one of the battery officers. As the geodetic points selected are almost always points of the tertiary triangulation, their exact location has not been determined with as much exactitude as might be desired. If the observations on the sun or Polaris are used as an orientation basis, such observations are usually made by an officer not accustomed to such work, and the same precision cannot be expected of him as might be expected from one more practiced in the work. Orientation of fixed batteries has been done by competent surveyors, and the work checked and rechecked until no possibility of error exists. Such battery commanders can therefore put aside all consideration of matters of orientation.

* * * * *

c. In fixed defenses the communication lines are a permanent installation and give very little trouble. In the case of railway artillery the lines of communication must be installed for each position, and each time the position is used it is necessary to send time interval signals over an intelligence line to the observers and readers, instead of operating these signals over separate lines. This further complicates the problem.

d. Battery commanders of fixed defenses have no problem of gun installation to consider. In the railway artillery a battery commander must give up a large portion of the training period to the training of personnel in the proper method of installation of the materiel.

* * * * *

g. The location and orientation of an aiming rule are other possible sources of error which do not have to be considered by fixed batteries. The use of an aiming rule calls for the services of another reliable well-trained soldier whose duties are somewhat similar to those of a gun pointer.

h. A large part of the important plotting room apparatus of this and

all railway artillery batteries is of local construction, being made of wood and paper which stretch and become inaccurate.

i. In spite of these handicaps, the ranges at which these guns were fired was appreciably greater than those of ten and twelve-inch guns during the season of 1925 (twelve-inch long-range guns excepted).

Some of the difficulties mentioned above have been obviated; others will always be present. However, the results of these practices show that railway guns, in spite of their unstable mounts and the disadvantages inherent in a mobile gun, have reached a stage of development which make them a worthy complement to the fixed armament of the Corps.

MAXIM XXXVII

From the moment you are master of a position which commands the opposite bank, facilities are acquired for effecting the passage of the river; above all, if this position is sufficiently extensive to place upon it artillery in force. . . Hence it follows that if the grenadiers, ordered to pass the river for the protection of the bridge, should reach the other side, they would be destroyed by the fire of the enemy; because his batteries, placed at the distance of two hundred toises from the landing, are capable of a most destructive effect, although removed above five hundred toises from the batteries of the crossing force. Thus the advantage of the artillery would be exclusively his.

When a river is less than sixty toises (or one hundred and twenty yards) in breadth, and you have a post upon the other side, the troops which are thrown across derive such advantages from the protection of your artillery, that, however small the angle may be, it is impossible for the enemy to prevent the establishment of a bridge. In this case, the most skillful generals, when they have discovered the project of their adversary, and brought their own army to the point of crossing, usually content themselves with opposing the passage of the bridge, by forming a semi-circle round its extremity, as round the opening of a defile, and removing to the distance of three or four hundred toises from the fire of the opposite side.—Napoleon's Maxims of War.

The Battle of Chancellorsville

By MAJORS ELLIS, BROWN, JOHNSON, AND DAWSON

AFTER the battle of Fredericksburg, General Burnside was relieved from command of the Army of the Potomac and was replaced by General Joseph Hooker¹ who was a Corps Commander with an excellent reputation. The change was a popular one and served to revive the morale of the army, which had dropped to a low ebb after the Fredericksburg reverse.

Hooker at once initiated several changes, the most important of which were abolishing the grand divisions of Burnside and reestablishing corps organization in its stead, and organizing the cavalry into a corps for independent operations.

The Army of the Potomac consisted of eight corps under commanders as follows: I—Reynolds; II—Couch; III—Sickles; V—Meade; VI—Sedgwick; XI—Howard; XII—Slocum; and the Cavalry Corps under General Stoneman.² Its strength was about 113,000 infantry, 8000 artillery, and 11,000 cavalry. The guns of the artillery numbered 404.³ The Army was located on the left bank of the Rappahannock, opposite Fredericksburg, and its camps extended back to the Potomac.⁴ It was well equipped and organized, and Hooker spoke of it as "the finest army on the planet."⁵

The Confederate army under General Lee was located on the western bank of the Rappahannock, extending from Banks' Ford to Port Royal. It normally consisted of two corps, under Jackson and Longstreet, but the latter at this time was absent with two of his divisions south of the James River gathering provisions and did not rejoin the army until after the battle of Chancellorsville. At the beginning of the Chancellorsville campaign, Lee's strength was approximately 55,000 infantry and artillery, and 7000 cavalry. The guns of the artillery numbered 170.⁶ It was poorly equipped and clad and living on reduced rations.⁷

Both commanders planned to take the offensive. Hooker's plan was to turn the Confederate left. The Cavalry Corps under Stoneman, less Pleasanton's Brigade, was to start two weeks in advance of the main army movement and march via Culpepper and Gordonsville to cut Lee's lines of communication with Richmond and establish itself along his

1. 40 RR. 3.
2. 40 RR. 51.
3. 40 RR. 320.
4. 39 RR. 1058.

5. Steele, *American Campaigns*, p. 330.
6. 40 RR. 696.
7. Alexander *Military Memoirs*, p. 318;
40 RR. 597.

rear and hold or delay him in retreat. A demonstration was to be made on the Confederate right, south of Fredericksburg, while the main force under Hooker was to cross the Rappahannock at fords to the north of Fredericksburg, turning the Confederate left flank.⁸

Lee was planning an invasion of the north. He had written Mr. Davis relative to taking the initiative but no definite plans had been made.⁹

Hooker began to put his plan in operation by dispatching Stoneman around the Confederate left on April 12.¹⁰ Owing to rains and swollen streams, Stoneman was delayed two weeks and did not effect

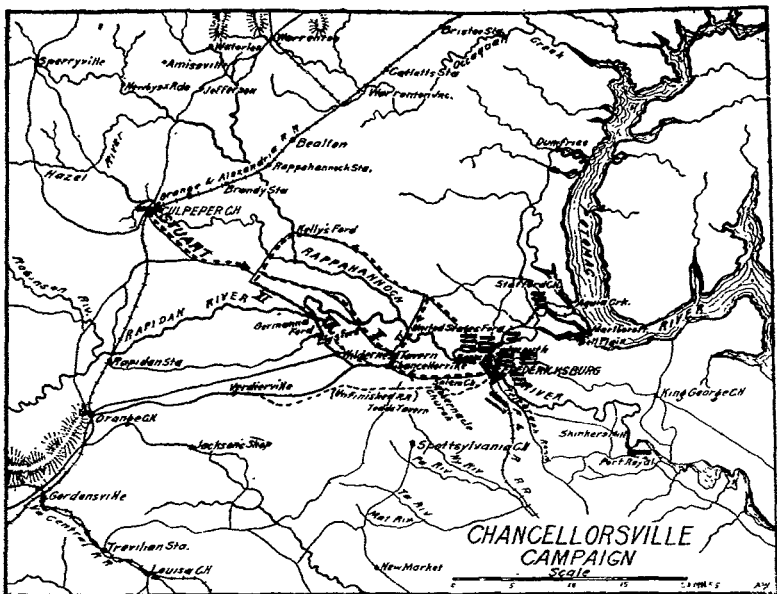

FIG. 1 CHANCELLORSVILLE SITUATION, APRIL 27-30, 1863.

a crossing of the Rappahannock until the same time as the infantry. This corps was then divided, one column under Averill operating toward Gordonsville and the other under Buford to the south along the Fredericksburg—Richmond railroad.¹¹ Averill was recalled by Hooker and reached Ely's Ford on May 2.¹² He operated on Hooker's right on May 3. Stoneman divided Buford's command into several detachments and sent them throughout the southern part of Virginia.¹³ While these detachments made some effective raids and did considerable damage, nothing material to the issue was accomplished.

8. 40 RR, 199; 40 RR, 268.

9. 40 RR, 700; Alexander, p. 322.

10. 10 RR, 215.

11. 39 RR, 1058.

12. 39 RR, 1076.

13. 39 RR, 1058; 39 RR, 65.

Hooker commenced his main movements on April 27. The V, XI, and XII Corps completed the crossing of the Rappahannock at Kelly's Ford on April 29. The force reached Chancellorsville on April 30, the V Corps having advanced by way of Ely's Ford and the XI and XII by way of Germanna Ford. It was preceded by Pleasanton's cavalry.¹⁴ Two divisions of the II Corps marched by way of the United States Ford and joined Hooker with the other corps on April 30. One division of this corps (Gibbon) remained at Falmouth.¹⁵ Sedgwick, with the I and VI Corps, crossed the Rappahannock below Fredericksburg on the twenty-ninth, with orders to make a demonstration of attack and, if the enemy should retreat, to pursue.¹⁶ The III Corps remained on the eastern bank as Sedgwick's reserve.

Lee was kept informed of the Federal movements principally through Stuart's cavalry.¹⁷ Anderson's division had been sent to Chancellorsville but Lee made no further changes in the dispositions of his forces until Hooker reached the place on the thirtieth.¹⁸ Lee had then become aware of Hooker's intentions of turning his left, and he determined to leave sufficient troops to hold his lines along the Rappahannock and with the main body of the army to advance on Chancellorsville and give battle to Hooker. Early's division of Jackson's corps, and Barksdale's brigade of McLaw's division, with part of the reserve artillery, totalling about 10,000 men, were entrusted with the defense of the position at Fredericksburg. At midnight on the thirtieth, McLaws, with the remainder of his division, marched toward Chancellorsville. Jackson marched at dawn the next morning with the remainder of his corps. At 8:00 A. M., May 1, he reached the position occupied by Anderson, who had retired from Chancellorsville upon Hooker's arrival and entrenched along a line near the intersection of the Mine and Plank roads and Tabernacle Church. Preparations were made immediately to advance, which was begun at 11:00 A. M.¹⁹ Lee's total force numbered about 40,000, while Hooker's numbered approximately 72,000.²⁰

About 11:00 A. M., May 1, Hooker moved out from Chancellorsville preceded by Pleasanton's cavalry, in four columns, as follows: The XII (Slocum) followed by the XI (Howard) marched on the Plank Road.²¹ Sykes' division of the V (Meade) followed by Hancock's division of the II (Couch), went by the Turnpike. The remainder of Meade's corps, Griffin's division followed by Humphrey's, took the river road.²² French's division of the II Corps was to turn off and

14. 39 RR. 505. 506; 39 RR. 627, 628;

39 RR. 667-670.

15. 39 RR. 305.

16. 40 RR. 268.

17. 39 RR. 1015; 39 RR. 791. 795.

18. 39 RR. 850.

19. 39 RR. 797.

20. Alexander. p. 324.

21. 39 RR. 627; 39 RR. 670.

22. 39 RR. 507; 39 RR. 311.

march to Todd's Tavern, but it was later withdrawn and placed in reserve.²³ The III (Sickles) had been recalled from Sedgwick, arriving at 9:00 A. M., May 1, and was left at Chancellorsville in reserve, one brigade being sent to Dowdall's Tavern, to protect the approaches from the west and another being sent to the United States Ford.²⁴

Lee's forces were disposed as follows: Anderson's division covered both the Plank Road and the Turnpike, with three brigades on the former and two on the latter. McLaws' division followed on the Pike. Jackson's corps of three divisions followed on the Plank Road.²⁵

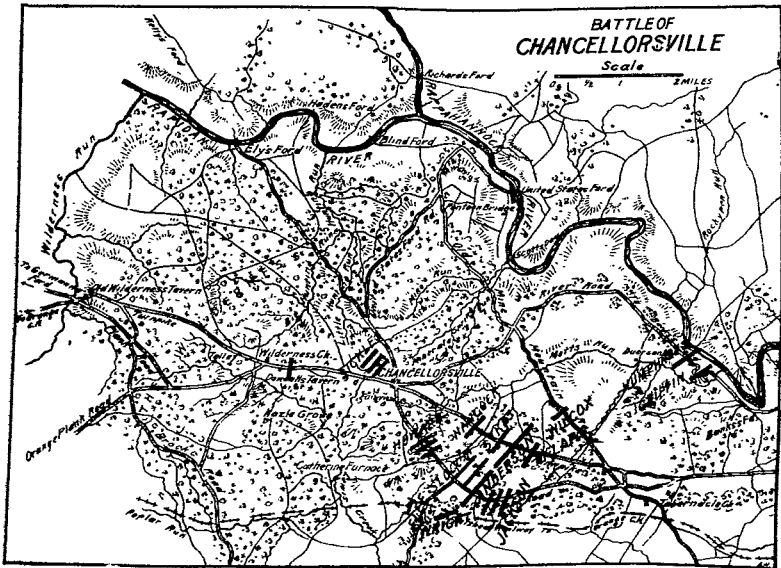

FIG. 2 CONTACT POSITIONS, AFTERNOON OF MAY FIRST

The terrain in the vicinity of Chancellorsville was very difficult for maneuver or battle. It consisted of a tract called the Wilderness, stretching some twelve or fourteen miles westward along the Rapidan and was some eight or ten miles in breadth. The original forest had been cut for charcoal many years before, and had been replaced by a second-growth forest of thick and tangled underbrush. A few clearings, seldom more than a few hundred yards in width, were scattered at intervals. The terrain was cut up by numerous crooked little streams with marshy banks. Chancellorsville was merely a brick residence at an important junction of roads with a considerable clearing to the west. Three roads ran toward Fredericksburg: the old turnpike most directly; the Plank Road to its right but uniting with the turnpike at

23. 39 RR, 305.

21. 39 RR. 384; 39 RR. 413.

25. 39 RR, 797.

Tabernacle Church, about half way; the River Road to the left, by a roundabout course passing near Banks' Ford of the Rappahannock. The only commanding ground in the vicinity of Chancellorsville was at Hazel Grove and Fairview, to the southwest.

The forces were in contact early on the afternoon of May 1 about two miles east of Chancellorsville. The troops on the Pike were the first engaged. Sykes' orders were to advance to Mott Run and connect with Griffin on his left and Slocum on his right. Soon after contact his position was menaced by the extension of the Confederate lines beyond his left flank.²⁶ On the Plank Road, Slocum formed line with his right resting on the road. His position was threatened by Wright's brigade of Anderson's division, which had advanced upon the line of an unfinished railroad about a mile south of the Plank Road.²⁷ There was considerable desultory fighting and skirmishing but none of the troops had become seriously engaged. The two divisions of the V Corps, Humphreys and Griffin, on the Federal left had reached a position within sight of Banks' Ford without meeting any opposition.²⁸ At this time Hooker issued orders for the withdrawal of his forces to their original lines at Chancellorsville.²⁹

This withdrawal was effected without difficulty,³⁰ the Confederates keeping contact but pursuing with caution until the Federal forces were within their original lines at Chancellorsville.³¹

At Chancellorsville, the Federal army took up a defensive position about five miles in length, reaching from the Mine Road near Scott's Dam on the Rappahannock around to Talley's Farm on the Turnpike west of Chancellorsville.³²

The V Corps (Meade) held the left of the line facing to the southeast on the high ground between Mine Run and Mineral Spring Run. Then came the II Corps (Couch) facing nearly to the east and covering the roads approaching Chancellorsville from the east.³³

The XII Corps (Slocum) was formed around the crest of Fairview Hill and facing southward. There was a gap of about half a mile in the line and the XI Corps (Howard) extended the right flank along the Turnpike facing south to Talley's Farm.³⁴

The III Corps (Sickles) took position in reserve at Chancellorsville.³⁵

The Confederate troops were formed in line in front of Chancellorsville at right angles to the Plank Road, extending from the Mine Road on the right nearly to Catherine Furnace on the left,³⁶ Anderson's

26. 39 RR, 193; Alexander, p. 325;

Steele, p. 335.

27. 39 RR, 507; 39 RR, 525.

28. 39 RR, 797; 39 RR, 866.

29. 39 RR, 507.

30. 39 RR, 526; 39 RR, 670.

31. 39 RR, 797.

32. 39 RR, 669, 797.

33. 39 RR, 306, 507.

34. 39 RR, 677, 673.

35. 39 RR, 388, 404.

36. 39 RR, 797, 825, 850.

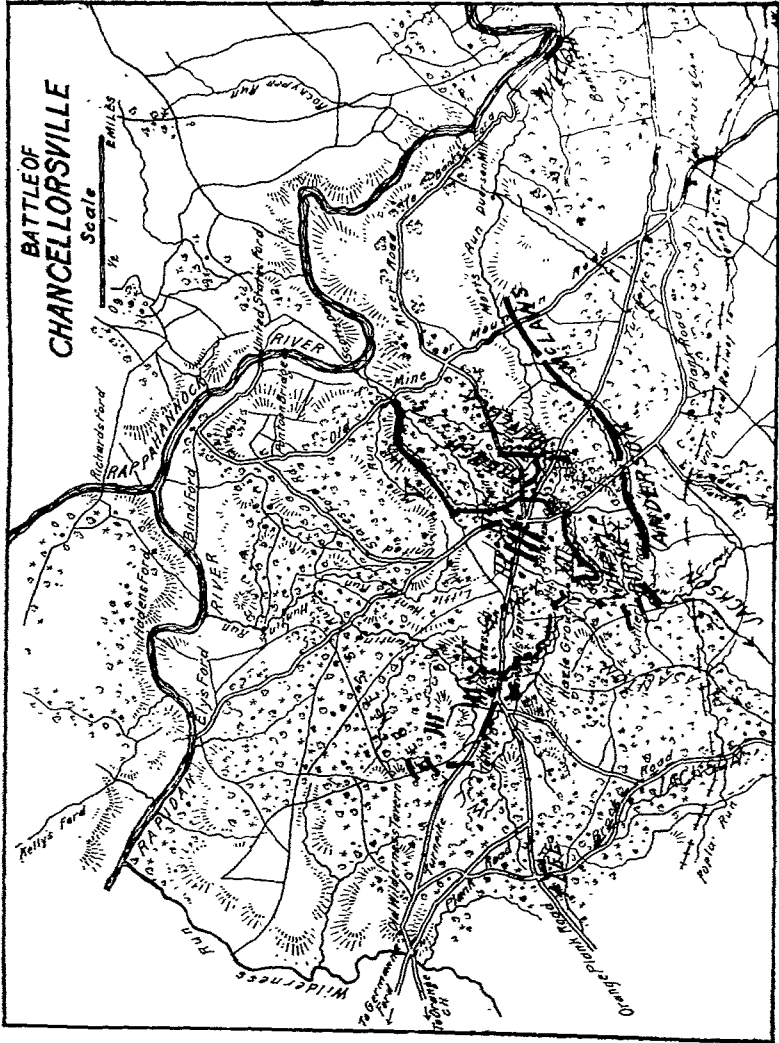

FIG. 3 START OF JACKSON'S MARCH, MORNING OF MAY SECOND

division on the left of the line and McLaws' division on the right.

At daybreak of the second, two brigades of Birney's division of the III Corps which was in reserve with two field batteries, took position in line between the XI and XII Corps at Hazel Grove.³⁷

General Lee decided to turn the Federal right flank, which was up in the air³⁸ and gain the Federal rear.³⁹ The plan was for the divisions of Generals McLaws and Anderson, with the exceptions of Wilcox's brigade, which during the night had been ordered to Banks' Ford⁴⁰ to contain the Federal forces in their front while General Jackson with his three divisions marched around and attacked the Federal right flank.⁴¹

Early on the morning of the second, Jackson, covered on the front and right flank by Fitzhugh Lee's cavalry,⁴² marched by the Furnace Road, which runs towards the southwest and in the direction of the road to Orange Court House, one of Lee's possible lines of retreat. Having crossed the unfinished railroad, he turned to the west, reached the Brock Road, and followed this road to its intersection with the Plank Road and then continued on to the Turnpike.⁴³

This movement of Jackson's across the front of the XI and XII Corps was not unnoticed by the Federal forces. In fact, the march was reported time and time again, but it is evident that the higher commanders thought the Confederates were retreating.⁴⁴

Reconnaissance detachments were sent forward along the fronts of both the XI and XII Corps, and everywhere they encountered Fitzhugh Lee's cavalry, but they were not sufficiently strong or energetic enough to pierce the covering forces, and consequently the Federals remained in ignorance of the true meaning of the move.⁴⁵

Jackson left one regiment at the Furnace to guard the flank of the moving column from surprise.⁴⁶ The column at this point drew artillery fire from batteries at Hazel Grove during the morning, but by altering its march slightly proceeded with no delay.⁴⁷

About 12:00 Noon, Sickles received orders from Hooker to advance cautiously towards the road followed by the moving column and harass the movement.⁴⁸ He sent Birney's division forward to pierce the enemy column and gain possession of the road over which he was passing.⁴⁹ Birney advanced and was soon reinforced by Whipple's division.⁵⁰ Later Williams' division of the XII Corps left its place in line and came up on the left.⁵¹

37. 39 RR, 383, 408.

38. 39 RR, 651.

39. 39 RR, 798, 834.

40. 39 RR, 855, 798.

41. 39 RR, 798.

42. 39 RR, 887, 798.

43. 39 RR, 900, 798, 940.

44. 39 RR, 634, 637, 408, 386.

45. 39 RR, 651, 634.

46. 39 RR, 979, 975.

47. 39 RR, 408, 443, 386.

48. 39 RR, 386.

49. 39 RR, 386, 408.

50. 39 RR, 386, 408.

51. 39 RR, 678, 670.

Geary's division of the XII Corps also moved forward at 5:00 P. M. "for the purpose of cutting off the trains of the enemy, who was supposed to be retreating toward Gordonsville."⁵²

In addition, Barlow's brigade, the only reserves of the XI Corps, had been ordered at 4:00 P. M. to Sickles' assistance,⁵³ and at the same time Pleasanton's cavalry, the only cavalry that Hooker had for reconnaissance purposes, was ordered by him to join Sickles to assist in the pursuit of the enemy's wagon train.⁵⁴

Since Jackson's attack, as will be seen later, started at 6:00 P. M., all the above troops at that time were engaged in attempting to destroy

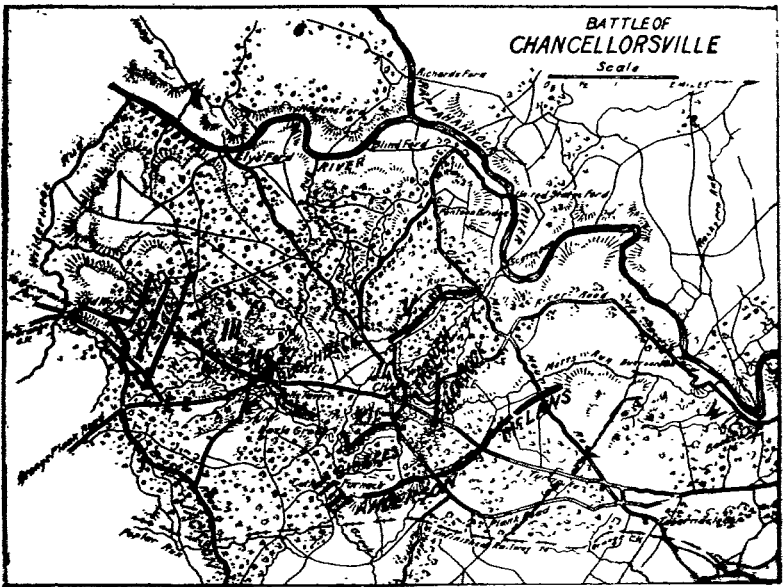

FIG. 4 JACKSON'S ATTACK AT 6:00 P. M., MAY SECOND

Jackson's column after it had passed. These forces were opposed by two of Anderson's brigades, whose forces kept closing in to the left, those of McLaws also keeping in touch with Anderson's right.⁵⁵ The net result of their efforts was the capture of the lone regiment left by Jackson to protect his flank.⁵⁶

The XI Corps under Howard holding the right of the Federal line was disposed as follows: The 1st Division on the right, with two regiments facing perpendicular to and north of the Old Turnpike, two regiments in reserve and the rest facing south parallel to the Turnpike.

52. 39 RR, 730, 670.

53. 39 RR, 630, 645.

54. 39 RR, 387, 772.

55. 39 RR, 851, 867, 871.

56. 39 RR, 940.

The 3d Division, next in line, faced generally south, with four regiments in reserve. Next was the 2d Division, with two regiments in reserve. The Corps reserve, Barlow's brigade of the 2d, had been sent to the assistance of Sickles.⁵⁷ Prior to the attack, two reserve regiments of the 3d Division were faced to the west in rear of, slightly to the right of, the right of the 1st Division.⁵⁸

Jackson launched his attack about 6:00 P. M. with his three divisions in column in the order Rodes, Colston, A. P. Hill.⁵⁹ The attack came as a complete surprise and the 1st and 3d Divisions were quickly routed and fled in wild disorder.⁶⁰ The lone brigade of the 2d Division made a determined stand in a series of rifle pits that had been previously constructed perpendicular to the road.⁶¹ but upon being enveloped on both flanks were compelled to fall back. At this point, Colston's division overtook Rodes and joined him in assaulting the Federal trenches, the two divisions pushed on from here intermingled in a confused mass.⁶² At this time, one of Pleasanton's cavalry regiments, recalled when the attack started, charged the Confederate right and succeeded in temporarily halting it.⁶³ Also, Pleasanton had succeeded in getting twenty-two pieces of artillery in position at Hazel Grove and opened up on the advancing troops just at dark.⁶⁴ This, in connection with the cavalry charge and the fact that darkness had fallen, halted the attack. Shortly after dark, Jackson was wounded and A. P. Hill assumed command, but was also wounded shortly thereafter, and Stuart was sent for and arrived at the front about 10:00 P. M.⁶⁵

In the meantime Berry's division of the III Corps supported by Hays' brigade of the II Corps formed line along a small brook at the foot of Fairview Hill⁶⁶ and at the same time guns were placed in position on the hill.⁶⁷ Sickles had been busy since the start of the attack in withdrawing his forces from the Furnace to Hazel Grove.⁶⁸

On the Confederate side the division of A. P. Hill had relieved those of Colston and Rodes and the latter two withdrew to reorganize.⁶⁹

About midnight, Birney, of Sickles' corps, made a moonlight attack on the Confederate flank, but outside of causing considerable confusion on both sides there was no material damage.⁷⁰

At daylight May 3, Sickles was ordered by Hooker in person to withdraw from his position on the flank at Hazel Grove and march his command to Fairview.⁷¹ Thus Hooker gave up without a fight

57. 39 RR, 628, 637.
 58. 39 RR, 652, 666.
 59. 39 RR, 798.
 60. 39 RR, 678, 951, 973, 894.
 61. 39 RR, 645, 941.
 62. 39 RR, 941, 1005.
 63. 39 RR, 784, 773.
 64. 39 RR, 773, 787.

65. 39 RR, 887, 799.
 66. 39 RR, 388, 679.
 67. 39 RR, 620, 675.
 68. 39 RR, 387.
 69. 39 RR, 1005, 911.
 70. 39 RR, 917, 670.
 71. 39 RR, 390.

the only place from which artillery could properly support an attack on Fairview, which will be seen to have been the key to the position at Chancellorsville.

Anderson and McLaws had received instructions that as soon as they heard the sound of Jackson's cannon they were to press strongly the Federal forces in this front to prevent the withdrawal of reinforcements from the front, but not to make a determined attack unless a favorable opportunity presented itself. McLaws was also to keep in contact with Anderson's right.⁷²

With the exception of the brigades used by Anderson to meet

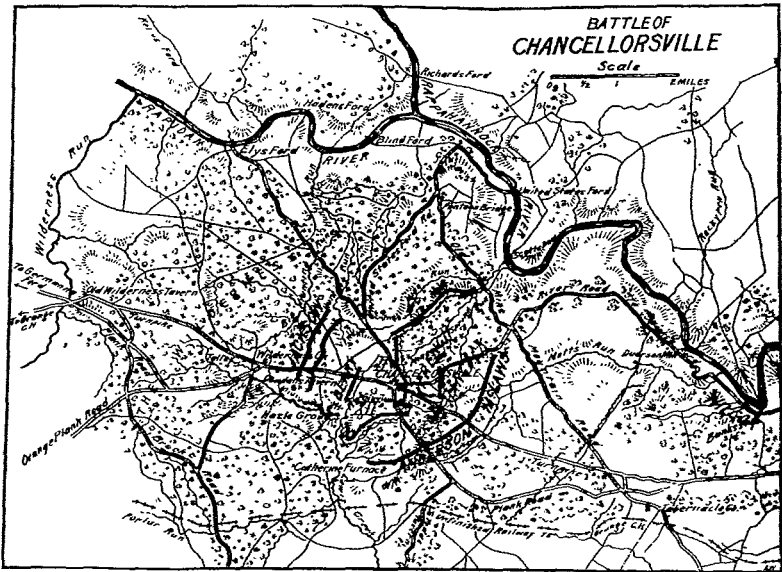

FIG. 5 BATTLE POSITIONS AT DARK, MAY SECOND

Sickles' attack at the furnace, these troops were not seriously engaged.

At dawn on the morning of May 3, Stuart, in command of Jackson's corps, renewed the attack. Hill's division was in front, with Colston in the second line and Rodes in the third.⁷³

As the mist lifted, it was discovered that the ridge on the extreme right, now unoccupied by the Federals, was a fine position for concentrating artillery, with the result that thirty pieces were ordered to Hazel Grove, a position overlooking and commanding the Federal⁷⁴ salient.⁷⁵

72. 39 RR, 799. 826.

73. 39 RR, 799.

74. 39 RR, 387.

75. 39 RR, 390.

On the Union side, the XI Corps (Howard), that had been routed by Jackson's flank attack, was being reorganized at the extreme left of the Union position. Opposing Stuart were three corps occupying two parallel defensive lines about $1\frac{1}{4}$ miles long, strengthened by earthworks and logs.

On the right was the II Corps (Couch), III (Sickles), and XII (Slocum). About thirty pieces of Union artillery was massed on the crest of the hill at Fairview, behind earthworks. This artillery was in a commanding position and admirably served, inflicting terrible blows upon the Confederates. It was withdrawn on account of the lack of ammunition and concentration of the Confederate attacks.⁷⁶

The breastworks at which the attack was suspended the preceding evening were carried by Stuart's assault under a terrible fire of musketry and artillery. Advancing, they assailed a second breastwork. Three times were these works carried and as often were the assailants compelled to abandon them.

General Anderson, in the meantime, pressed gallantly forward and joined Stuart's line and with a concerted attack the whole Confederate line pushed forward.

The Confederate line went forward to Fairview and by 10:30 A. M. Chancellorsville was a smoking ruin, with the Union forces retiring to lines in rear, which had been prepared by the Engineers during the night.

One of the most serious engagements of the whole campaign had been fought with only three Corps engaged. The Corps Commanders of the I and V Corps were eager to use their forces but were held in reserve by Hooker. The area was very restricted and unsuited for maneuvering large bodies of troops; it was even more so now.

General Lee's lines closed in on the new defensive position and was preparing again to launch a concerted attack against the Union position when attention was called to events happening around Fredericksburg.⁷⁷

The original command of General Sedgwick had consisted of three corps. On the night of April 30 the III Corps (Sickles), which had supported Sedgwick's crossing from the north bank of the Rappahannock, was ordered to join the forces of General Hooker at Chancellorsville via the United States Ford.⁷⁸

On May 2 the I Corps (Reynolds), in position covering the lower crossing on the river below Fredericksburg, was also withdrawn and ordered to Chancellorsville.

76. 39 RR, 391.

77. 39 RR, 800.

78. 39 RR, 558; 40 RR, 308.

At 11:00 o'clock on the night of May 2, General Sedgwick received the following order from General Butterfield, Chief of Staff of the Union Army at Falmouth:

The Major General Commanding directs that you cross the Rappahannock at Fredericksburg on the receipt of this order and at once take up your line of march on the Chancellorsville road until you connect with him. You will attack any force you may fall in with on the road. You will probably fall upon the rear of the forces of General Lee and between you and the Major General Commanding, he expects to use him up.⁷⁹

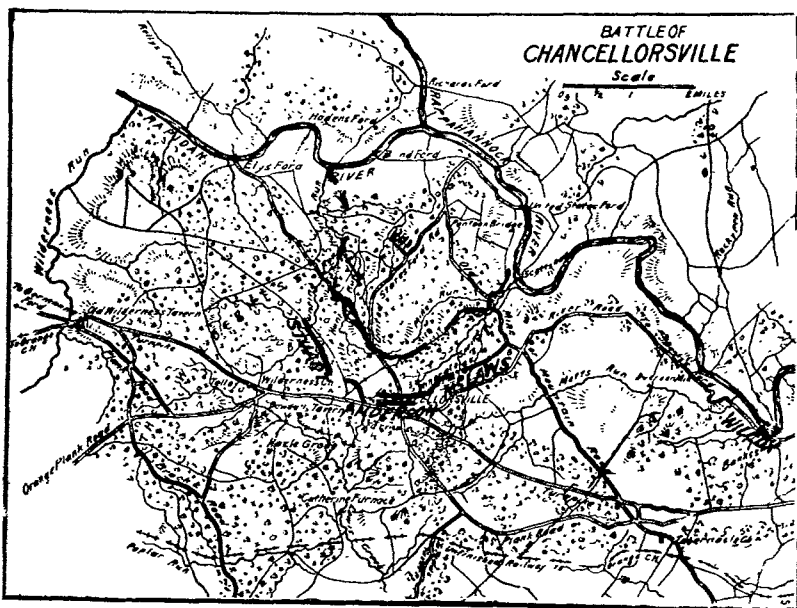

FIG. 6 SITUATION AT 10:30 A. M., MAY THIRD

Sedgwick had been repeatedly informed by Butterfield, Chief of Staff, that the forces confronting Sedgwick were very small and the tenor of his dispatches were that the Confederates had abandoned the vicinity of Fredericksburg. The order stated that Sedgwick was to cross at Fredericksburg, while the command was at present on the south side of the river.

In cooperation with the movement of Sedgwick, a second force under General Gibbon was ordered to take immediate possession of Fredericksburg. Gibbon's force consisted of the 2d Division (less one brigade) and was to cross to the northern part of Fredericksburg by pontoon bridges.⁸⁰

⁷⁹ 39 RR, 558; 40 RR, 365.

⁸⁰ 39 RR, 350.

On the Confederate side opposing Sedgwick was Early's division along the ridge below Fredericksburg. At Fredericksburg, occupying Marye's Heights, was Barksdale's brigade extending from the Rappahannock above Fredericksburg to the rear of the Howeson's house, a distance of more than two miles. The artillery was posted along the heights in rear of the town.⁸¹

On receipt of Hooker's order, Sedgwick moved his command at once by the flank to Fredericksburg. The advance guard skirmished with the Confederates all the way, entering Fredericksburg at 3:00 A. M., May 3. Confederate detachments, opposing Gibbon's crossing by pontoon bridge, were driven back.

Four regiments were sent forward against the rifle pits to make an assault and were repulsed by rifle and artillery fire from Marye's Hill. At daylight it was evident to Sedgwick that the Confederates were in considerable force extending both to the right and left and, to continue the advance, the Confederate position must be carried by assault.

In the meantime, Early was reinforcing the Confederate position. One brigade (Hays) from the extreme right, was sent to support Barksdale. Wilcox's brigade at Banks' Ford marched on Fredericksburg and occupied Taylor's Hill in time to stop Gibbon's advance at the canal northwest of Fredericksburg.

Sedgwick moved to the assault with Gibbon on the right and Howe on the left, against Marye's and the hills to the right and left. Two assaults were repelled by Bardsdale's men and the artillery. A flag of truce was sent from the town to obtain permission to provide for the wounded. Immediately afterwards three heavy assaulting columns advanced and overpowered the force at the foot of Marye's Hill by over ten times their number and advancing carried the hill, capturing guns and many prisoners.⁸² Sedgwick's entire corps was put in motion, moving in pursuit of Early on the Telegraph Road, threatening communications of the Confederates and leaving the road open to Chancellorsville.

Sedgwick in carrying out Hooker's instruction to march on Chancellorsville stopped the pursuit and marched via the Plank Road directly to Lee's rear, leaving Gibbon's forces occupying the Marye's Heights.

Wilcox delayed the advance, falling back slowly until he reached Salem Church on the Plank Road about five miles from Fredericksburg. This information having reached Chancellorsville, McLaws, with four brigades, was ordered to reinforce Wilcox. McLaws reached Salem Church early in the afternoon where he found Wilcox's command deployed and confronted by Sedgwick's corps.

⁸¹. 39 RR, 800; 39 RR, 1000.

⁸². 39 RR, 559, 801.

McLaws extended the lines of Wilcox to the right and left, placing two brigades on each flank. Sedgwick advanced to the attack in three strong lines directed mainly against Wilcox's position. The assault was met by the Confederates and the first line repulsed with great slaughter. The second line came forward, but broke under the deadly fire. The Confederates counterattacked with two brigades, driving the Union forces back to the reserves. The combat kept up until it was

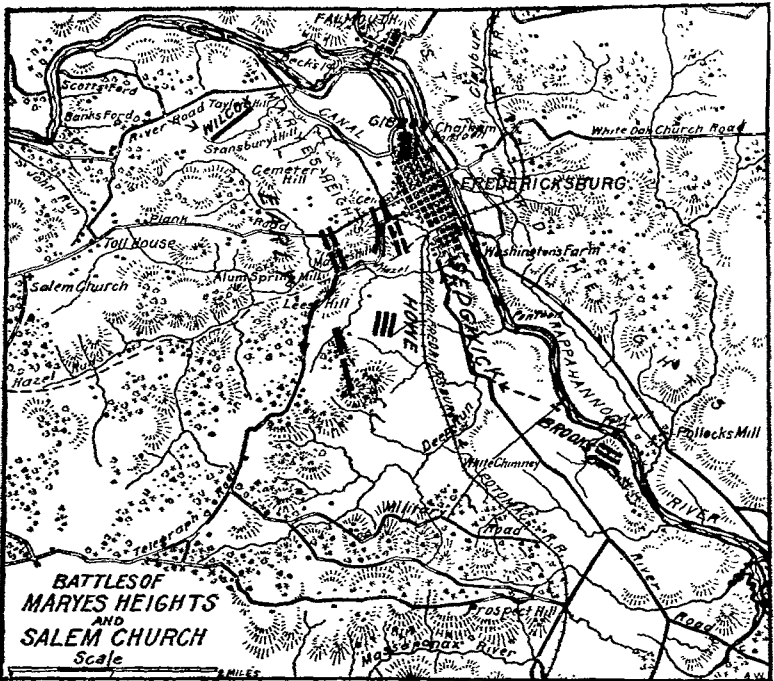

FIG. 7 MARYE'S HEIGHTS SITUATION AT DAWN, MAY THIRD

dark.⁸³ Sedgwick's march was stopped and he had lost nearly 5000 men since morning, and Hooker had made no effort to take the offensive and join up with Sedgwick's thrust.

On the night of May 3-4, Hooker contracted his lines and further strengthened his position, hoping that Lee would attack him, and sending word to Sedgwick to look well to the safety of his corps, preserving communications with Fredericksburg and Banks' Ford.⁸⁴

As it did not appear to Lee that Hooker's force was going to take the offensive, he resolved further to reinforce the troops in front of Sedgwick. Accordingly, on the morning of May 4, Anderson was

83. 39 RR. 827. 559.

84. 39 RR. 560: 40 RR. 396.

directed to proceed with his three brigades to join McLaws and capture Sedgwick's forces or drive him across the river. This left Jackson's three divisions holding the front of Hooker's six army corps. The following message is quoted from Hooker to Sedgwick:

May 4, 1:20 P. M., 1863

I expect to advance tomorrow morning which will be likely to relieve you. You must not count on much assistance without I hear heavy firing.⁸⁵

Early advanced along the Telegraph Road on the morning of May 4, cutting Sedgwick's communications with Fredericksburg, capturing Marye's and driving Gibbon's forces to the river crossing at Fredricksburg. Early then marched to Salem Church attacking Sedgwick in rear and establishing communications with McLaws.⁸⁶

Anderson had been delayed several hours in getting away from Chancellorsville and also in forming line for attack, owing to Sedgwick's peculiar rectangular formation. It was six o'clock in the evening before the Confederates made a coordinated attack, driving Sedgwick down to Banks' Ford. Fortunately for Sedgwick, darkness came and the conflict stopped.

On May 5 at 2:00 A. M., Sedgwick received an order from Hooker to withdraw across the river and cover the position at Banks' Ford. When the last column was on the bridge, an order was received countermanding the withdrawal. At this time it was too late to recross in the face of the enemy and under fire.

On the morning of May 5, Sedgwick had made good his escape and removed his bridges. Fredericksburg was evacuated by Gibbon. Lee left Early's division and Barksdale's brigade to cover Fredericksburg and with the divisions of McLaw and Anderson marched on Chancellorsville with the purpose of destroying Hooker's forces. They reached their positions in the midst of a violent storm, which continued during the night of May 5 and most of the following day. Preparations were made to assail Hooker's positions on the morning of the sixth, but Lee's advancing skirmishers found that Hooker, under cover of the storm and darkness, had made good his escape across the Rappahannock.⁸⁷

COMMENTS

The first movements of the main force in the Chancellorsville campaign began on April 27, 1863, and the final ending of the campaign occurred with Hooker's withdrawal across the Rappahannock on the night of May 5, 1863.

85. 30 RR. 108.
86. 39 RR. 802, 852.

87. 39 RR. 802.

Ford (at the same time forming a connecting link with General Sedgwick) before the arrival of General Jackson. This would have taken him out of the Wilderness, where he would have had more open ground for the maneuver of his forces, and virtually united his army. A night's march would have brought him upon the rear of Lee's army at Marye's Heights with only Anderson's division to brush aside. Notwithstanding this opportunity, Hooker did not move out until 11:00 A. M., May 1. Before he got out of the forest, he met Lee with 40,000 men who had effectually blocked the four roads by which the Federals would have to advance from the Wilderness. Although the general line of the Federals was a good one, with large open spaces where the artillery could maneuver, Hooker, despite the protests of his corps commanders, decided to withdraw to Chancellorsville before becoming seriously engaged. The withdrawal was based in part on reports from the balloon and signal officers that a force estimated as two corps was marching towards Chancellorsville, also deserters had brought rumors that Hood's divisions from Suffolk had rejoined Lee, but Hooker's information from Fort Monroe should have shown that to be impossible. Hooker realized from the rapid manner of Lee's approach and from the sounds of battle already heard, both on the Pike and Plank roads, that Lee meant to attack. He had confidently expected Lee to retire without a battle, and finding him, instead, so quick to take the aggressive, he lost his nerve. Hooker himself explains his falling back in the Wilderness as follows:

The forces on the Turnpike and Plank roads had proceeded but a short distance when the head of the column emerged from the heavy forest, and discovered the enemy to be advancing in line of battle. The 12th Corps had nearly all emerged from the forest at that moment, but as the passage-way through the forest was narrow, I was satisfied that I could not throw troops through it fast enough to resist the advance of General Lee, and was apprehensive of being whipped in detail.⁸⁹ When I marched out on the morning of May 1, I could get but few troops in position; the column had to march through narrow roads, and could not be thrown forward far enough to prevent their being overwhelmed by the enemy in the advance.⁹⁰

General Humphreys testified that:

We should not have been withdrawn on Friday afternoon. We had advanced along the road to Fredericksburg to attack the enemy; the troops were in fine spirits, and we wanted to fight a battle. They came out, and attacked one division of the Corps I belonged to just at the time we returned to Chancellorsville.⁹¹

89. Dodge, *The Campaign of Chancellorsville*, p. 50.

90. *Idem*.
91. *Ibid.*, p. 51.

Lee appreciated that Hooker's withdrawal in the Wilderness was not forced, but to fortify and concentrate. He stated that "Hooker assumed a position of great natural strength, surrounded on all sides by a dense forest, filled with a tangled undergrowth, in the midst of which breastworks of logs had been constructed with trees felled in front so as to form an almost impenetrable abatis." Hooker had, indeed, maneuvered Lee out of his position without a battle.

Jackson's flank march on May 2 was as brilliant an operation as Hooker's grand turn. His maneuver, like Hooker's, was little favored by secrecy or concealment, and owed its success particularly to being mistaken for a retreat towards Gordonsville.

When Jackson had reached the right and rear of the line at 4:00 P. M., Hooker complacently viewed the situation from his comfortable headquarters at the Chancellor House, apparently in a semi-torpid state, retaining just enough activity to initiate maneuvers which under the circumstances were the most unfortunate possible. Both he and Howard—and the rest—knew that this Confederate column was marching, yet made no effort to destroy it and no adequate preparation to oppose it. Hooker had robbed his right corps of Barlow's brigade; he dispatched Birney two miles into the woods, supported by Whipple and protected on the left by Williams. About 5:00 P. M. he ordered Geary from his position on Slocum's left to move forward and made an attack down the Plank road. Geary carried out the order in person with several regiments, and when considerably advanced, about sundown, he was ordered to return to his position. The right flank, of less than 10,000 men, was thus isolated from the rest of the army, with no supports within two miles. With full evidence of Jackson's whereabouts before him and thoroughly conversant with the situation from his own inspection of the line, Hooker allowed the key of his position to depend upon a half brigade and two guns.⁹²

Never was the cavalry more needed in the right place than Hooker's cavalry was needed on the exposed right flank that second of May. Here Hooker had made a mistake, and it cost him dearly. He had sent off with Stoneman his entire cavalry force, except one brigade. This proved insufficient to keep him informed of the Confederate movements, even though their efforts were supplemented by many signal officers with lookouts and field telegraphs and two balloons. Just before Jackson rushed upon Howard's right, a reconnoitering party of Howard's cavalry went into the woods in front of the 26th Wisconsin. Upon returning about ten minutes later, it informed the officers of this regiment that everything was all right, and then quietly returned to

92. General Lee's personal statement.

rest behind Hawkin's Farm.⁹³

If Stoneman's cavalry had been on the Federal right flank, Fitzhugh Lee would not have been permitted to discover that Howard's flank was exposed.

Had Sickles been supported as he should have been in his movement beyond the Furnace he would have sent Jackson's column flying towards Richmond. He had been criticized for causing a gap in Hooker's line, which left the XI Corps without support. The officer responsible for the gap was the one who remained behind and not the one who had advanced; it was Howard and not Sickles.⁹⁴ Sickles, however, did fail to establish proper liaison and coordination during the night operations and actually attacked friendly troops in front of Fairview, mistaking them for Confederates.

Jackson's attack on May 2 terminated without having attained its object, due to the fact that the orders given by him were not fully carried out. He gave explicit orders that there should be no pause in the advance for fear of a Federal counterattack; but at 7:15 P. M. Rodes and Colston halted their lines. Their excuse was confusion and darkness.⁹⁵

If Jackson had been at the front, the advance would have continued, and had he not been wounded and disabled, he might have carried out his purpose of resuming the advance and coupling with it a movement against Hooker's line of retreat.

During the night of May 2, Hooker withdrew Sickles from Hazel Grove. This was a fatal error, as it allowed Stuart to seize the heights and place thirty guns there. From this point, further advancement of the Confederates rapidly continued until finally the flanks of Anderson's and Stuart's forces made connection at Fairview, thus uniting the Confederate line. By 10:00 A. M., May 3, Lee had possession of Chancellorsville.

Hooker erred in assigning Sedgwick to inaction. After Sedgwick, with the I and II Corps, had moved down the river and crossed below Fredericksburg on April 29, no real offensive mission was given him until Hooker dispatched an order at 9:00 P. M., the night before May 2, directing him to cross the Rappahannock, move through Fredericksburg, drive Early away, continue towards Chancellorsville, and be ready to attack Lee in reverse.⁹⁶ In the interval between, Sedgwick's attacks were pretended and more in the nature of demonstrations. If the enemy fell back, he was to pursue him. The following instructions were issued to the left wing at Chancellorsville May 1, 1863, at 11:30 A. M.: "General Butterfield:—Direct Major General Sedgwick to

93. 39 RR. 654.

94. Bigelow. p. 338.

95. Colston, in *Battles and Leaders*, III. 233.

96. 39 RR. 363.

threaten an attack in full force at 1:00 P. M., and continue in that attitude until further orders. Let the demonstration be as severe as can be, but no attack. (Signed) Joseph Hooker."⁹⁷

Stoneman's cavalry exerted no practical influence upon the campaign after the right wing had arrived at Chancellorsville. If it had been kept with the main body, instead of dividing it into two columns and sending it out on raids and destruction of railroads, it would have been of great service. Hooker held Stoneman responsible for Averill's failure to obey his order of May 1 to join him at Chancellorsville from Rapidan Station. Hooker remarked before the Committee on the Conduct of the War: "It is charitable to suppose that Generals Stoneman and Averill did not read their orders, and determined to carry on an operation in conformity with their own views and inclinations."⁹⁸

General Hooker's reasons for his withdrawal and recrossing of the Rappahannock were as follows:⁹⁹

- a. The rout of the XI Corps on May 2.
- b. His army had none of its trains of supplies with it.
- c. A heavy rain and consequent rise of the Rappahannock threatened to sever his communications.
- d. The nature of the country prevented his forcing the enemy's lines in his front.
- e. He wanted to get his army together and adopt a plan which would allow his directing the movements of the several corps himself.

Even though the XI Corps was routed, Hooker was stronger in men and in position than ever before. As to his trains and supplies, there were ample supplies along the north bank of the river ready to be hauled to the troops. His reference to the heavy rain and consequent rise of the Rappahannock threatening his communications is questioned. This rain did not set in until 4:00 P. M. on May 5, and his order to retire was given twelve hours before any rain and during a cloudless sky.¹⁰⁰ The nature of the country may have temporarily checked his operations against the Confederates, but it certainly did not justify his withdrawal across the Rappahannock.

Hooker's errors were largely due to his interference with his corps commanders, not allowing them to do what their own judgment dictated. His greatest mistake in this campaign was his final one of recrossing the Rappahannock.¹⁰¹

As for General Lee, Longstreet comments that Chancellorsville is usually accepted as his (Lee's) most brilliant achievement.¹⁰²

97. 39 RR, 388.

98. *Rep. of Com.* IV, 140.

99. Bigelow, p. 480.

100. Swinton, *Campaigns of Army of*

Potomac, p. 307.

101. Alexander, p. 358.

102. Longstreet's personal statement.

Danger Zones—Italy

E. E.

“FROM today onwards the nation is called to arms. From today onwards we are all of us Italians and only Italians. Now that steel has to meet steel, one single cry issues from our breasts, *Viva l'Italia!*” Thus wrote Editor Benito Mussolini in his paper, *Il Popolo d'Italia*, on May 24, 1915—the day Italy entered the World War. Intense national patriotism became the keynote of Mussolini's thought and action from that day forth. Events and his own powerful personality have placed him at the head of the Fascist Party, through which he now rules Italy. Hence, any consideration of present day Italy centers around Mussolini and the outgrowth of his strong nationalist policy.

To appreciate the strength of Mussolini's present convictions, we must trace their development. Before he was twenty years old, he associated himself with the Italian Socialist and Labor groups. Later, while working his way through university courses at Lausanne and Geneva, he organized labor unions and fomented strikes until the Swiss authorities finally expelled him from the country. In 1908 the Italian authorities imprisoned him for ten days as a result of his share in the agrarian disturbances in Romagna, and thereafter they considered him a dangerous revolutionary. His next work for the cause of Labor was in Austria, from which country the Austrians expelled him because of his outspoken views on Austrian domination of Italians in the Trentino. In 1911 he spent five months in an Italian jail, for organizing a popular movement opposed to the Government's policy in the Tripoli campaign. By 1914 he had risen high in the councils of the Italian Socialists. As a leader of the “Red Week” outbreaks during June of that year, he risked his life frequently; but his associates, more ready with words than with deeds, did much to undermine his faith in revolutionary socialism as a means of improving economic and social conditions in Italy. His views gradually diverged from socialist teachings, and though he still felt the need of revolutionary action, he broke away from the Socialists.

Italy's entry into the World War widened the breach between Mussolini and his former socialist associates. He went as a *Bersaglieri* private into the Isonzo and Carso trenches, and served faithfully for eighteen months, while the Socialists conducted a propaganda campaign that helped to destroy the morale of the army. Serious wounds from

By special arrangement between the editors and the author, this article appears in the current numbers of the COAST ARTILLERY and INFANTRY JOURNALS.

the explosion of a trench mortar ended Mussolini's soldiering early in 1917. After many months in the hospital, he returned to his journalistic work as editor of *Il Popolo d'Italia*, and printed repeated warnings against the defeatist propaganda that was flooding the country. When the Caporetto disaster all but overwhelmed Italian arms, he was one of the few who faced the issue with a stout heart and words of encouragement. The Socialists turned towards Bolshevism; Mussolini, to patriotism.

After the Armistice, Mussolini strove to combat the wave of Bolshevism that threatened to engulf Italy. His spirited journalism soon made his paper a power in the land; his organizing ability and fearless leadership won the support of many ex-service men who were willing to fight if necessary to keep the socialists from seizing control of the Government. At Milan on March 23, 1919, he organized the first unit of what later became the Fascist Party. Hostility to all Red activities, courage, and national patriotism, were the primary qualifications for membership in the new organization. The need for such an organization was desperate, for in many towns the Reds were in full control and were imposing revolutionary changes with tyrannical severity. During 1919 and the early part of 1920, the Fascisti slowly gathered strength; they formed the rallying points for all Italians who opposed the Reds. In 1921 and 1922, bloody encounters between Fascisti and the Reds occurred almost daily. First in the Po valley, and then throughout all Italy, the Fascisti broke the power of their opponents; their bravery and unselfish devotion to patriotism won many admirers, and their success in dealing summarily with the Red menace brought in thousands of members from all classes of society. Merchants, manufacturers, landlords, farmers, laborers, and finally masses of workers from the labor unions—all came under the spell of Mussolini's leadership in a nation-wide organization imbued with indomitable spirit. With that body solidly behind him, Mussolini swept the Bolshevized Socialists into the discard.

Such in brief is the background of the man who for more than five years has been Dictator in Italy. Before he rose to that position, he had tried Socialism and had found it wanting; he had served his country faithfully during and after the war; and he had entirely discredited all efforts to apply Bolshevik theories to Italian problems. Long and intimate association with workers, labor unions, and syndicalist labor movements had given him appreciation of Italy's industrial and economic problems. Wide reading, study, observation, and journalistic work had put him in close touch with many phases of Italian foreign relations. He had built up a powerful organization which put the

welfare of Italy and the Italian people above all else. For the subsequent developments in Mussolini's remarkable career, and in the affairs of Italy, we must turn now to the well-disciplined organization that maintains him in power—The Fascist Party.

Formally organized as a political party in 1921, the Fascist party constituted itself as the perpetual guardian of Italian material and spiritual welfare. It conceived the nation to be a limitless progression of generations, in which the living are responsible for the welfare of the race. Individuals and organizations may have life, liberty, and the pursuit of happiness only so far as these things serve to transmit a national heritage superior to that received from the past. Fascism is not liberal, for it represses seditious elements with an iron hand; it is not socialistic, for it encourages private ownership of property; it is hardly democratic, for it has disenfranchised millions who formerly had the right to vote. Fascism aims to protect the essential rights of each individual, but prohibits private assaults upon the rights of society. Frank admission that continued national welfare is paramount to all selfish considerations gives Fascism a firm basis for clean-cut policies in practical affairs. Strict adherence to this ideal has produced remarkable development in Italy's internal economy; what it is leading to in foreign affairs, we shall consider later.

Unity of effort is the basis of Mussolini's economic policy. He acts upon the belief that all forms of industry are directly or indirectly interdependent, and that the nation will profit from their cooperation. Strikes and lockouts are therefore illegal. Employers and employees must arbitrate their disputes; and if they are unable to agree, they must accept the ruling of a government labor tribunal. All who engage in productive work are classed as workers, and are encouraged to join the unions which the Government recognizes as essential to industrial progress. There are unions for managers, engineers, technicians, landlords, peasants, manual laborers, and others; then there are corporations which combine the various unions whose members are closely associated in each industry or type of labor. More than a dozen of these super-unions are now in operation. Employers and employees have not as yet been joined in the same corporation, but each class has representatives on coordination committees which help to eliminate friction. Fascism admits that private capital is essential to progressive industry, and has restored to private control some branches of business that the government formerly operated at a loss. The telephone service was thus restored to efficient operation; railways and parts of the postal service would have been similarly handled but for drastic reforms which converted huge annual deficits into profits. The Government aims

to impose reasonable restrictions and responsibilities upon all classes, in order that the State as a whole may prosper.

To date, this economic policy has produced excellent results in both government and private business. The number of government employees has been reduced and the quality of the service improved. Shortly after the Fascisti assumed control, they cut 55,000 names from the payrolls of the government railways alone. Revised private industries easily absorbed the workers discharged from the government service; in fact, the problem of unemployment, which is serious in England and troublesome in France, is almost non-existent in Italy. Strikes have ceased, production has increased, and the condition of the working classes has improved. Agriculture has profited greatly from the introduction of improved methods and from strenuous efforts to increase production. Mussolini himself set an excellent example for his people by taking an active part in the "battle of wheat." Imports from foreign wheat fields have fallen far below the pre-war average. The sugar beet industry, the manufacture of iron and steel products, textiles, mining, and hydro-electric developments are prosperous and expanding. The Italian merchant marine has better ships than before the war, and more than double the pre-war tonnage. Violent fluctuations in the value of the lire ceased at the end of last year with Italy's resumption of gold standard currency. In the fiscal year 1924-25, for the first time in many years, the government budget showed a surplus. The Fascist success is partly due to correction of flagrant abuses that had grown up under previous administrations, but mainly to the spirited execution of constructive new policies. Hard work, intense effort, and the determination to excel have marked the first five years of Fascism. As yet it is difficult to tell whether or not the new policies are well enough suited to the Italian people to confer permanent benefits. Work and duty, constantly dinned into weary ears, may pall after a while.

The political situation in Italy is monotonously one-sided. Fascism is firmly in the saddle, and apparently is well equipped to remain there indefinitely. Mussolini has won the admiration and confidence of the great majority of his countrymen, and his personal popularity is strong enough to counteract most of the censure that unfortunate incidents have brought down upon Fascism. The murder of the Socialist deputy Matteotti by Fascisti in June, 1924, aroused intense indignation, but Mussolini's supporters, both in and outside his party, remained true to their hero. Subsequently, the Fascisti put through a law which makes illegal the existence of other political parties in Italy. The attitude of the Fascisti towards the monarchy and towards the Vatican

has strengthened the support that Fascism receives from non-members. In September, 1922, about a month before Mussolini became Prime Minister, he announced that Fascism would support the monarchy. His fulfilment of that promise has banished the fears of many who once suspected the Fascisti of having a republican bias. Towards the Vatican, Fascism has displayed marked friendliness. There have been minor difficulties, but Mussolini recognizes the fact that the great majority of his people are Catholics, and that Catholicism occupies a particularly favored place in Italy. Both the Monarchists and the Catholics can, and do, consistently support Fascism.

Mussolini's most urgent political problem is to win national adherence to Fascist doctrine. Characteristically thorough and effective measures are now in operation to secure the desired result. The training of youth in the ideals, duties, and responsibilities of Fascism has become one of the most vital concerns of the Government. Mussolini feels that only when the oncoming generation has received thorough training in the Fascist school will Italy be ready and able to demand her proper place in the family of nations.

Exactly what share of the world Mussolini will eventually demand for Italy, nobody knows. His present foreign policy is largely the result of dissatisfaction with the settlements made at the end of the World War. Italy expanded her territory to the north and northeast in substantial conformity with the terms of the 1915 Treaty of London, under which she entered the war, but she received no part of the German colonies when they were divided among the Allies. Now that Italy has pressing need for territory in which to expand, she feels keenly that at the Peace Table her interests were sacrificed. Italy's population is now over 40,000,000, and the annual increase is remarkably large—so large, in fact, that the surplus is constantly overflowing Italy's present boundaries. This leakage of manpower through emigration to foreign soil is a thorn in the flesh of *Il Duce*. His only remedy is to secure territory which will accommodate the immigrants and still keep them under Italian sovereignty. As a result, Mussolini's foreign policy is aggressive both in theory and in practice.

Seemingly insignificant Albania furnishes the best example of how this policy works. Albania has become practically an Italian protectorate, despite the fact that the League of Nations guarantees its independence. Italian bankers control the finances of that country and have secured an exclusive concession for its economic development. Two years ago an Italian bank made Albania a loan of about \$10,000,000.00, added some \$4,000,000.00 to cover the cost of floating the loan, and wrote in a modest 7 per cent rate of interest to insure the creation of a

debt which Albania cannot possibly repay. If there is default on the loan, Italy is entitled to assume control of Albanian customs, which provide almost all of the government's income. The economic development of Albania now proceeds apace, with Italian military engineers in charge. The loan credits established in the Italian bank are paying for bridges and highways that run mainly from the Adriatic to the frontier of Jugoslavia. By treaty stipulations, Italy has agreed to maintain Ahmed Zogu at the head of the Albanian Government. Thus, along with finances and economic matters, Mussolini has Albanian politics under his thumb, and it requires no great feat of imagination to assign him control of Albanian foreign relations. Control of Albania gives Italy control of the Adriatic and nullifies the strategic value of Jugoslavian seaports. Albania provides Italy with well protected ports at Avlona and Durazzo, and an almost impregnable base for land operations on the Balkan peninsula. Barren, unproductive, and inhabited by fierce, warlike people, Albania in itself is not worth taking; strategically, it is tremendously important. If Mussolini sends Italian troops into Albania on any pretext whatever, he will touch off a fuse that may detonate the Balkans.

Italy has much to gain from a readjustment in the Balkans. On the eastern shore of the Adriatic, the Dalmatian coast offers a tempting field for Italian expansion. It now belongs to Jugoslavia and is peopled mainly by Slavs, but the more cultured elements of the population are of Italian origin. Possible Italian expansion into Dalmatia brings up consideration of the Little Entente. Jugoslavia, Roumania, and Czechoslovakia formed the Little Entente, largely as a result of French influence, to safeguard the territories awarded them after the World War. All of them have had continual trouble with the suppressed racial minorities, within their respective boundaries; all of them are weak from overgrowth. Without strong support from France, this weak association of weak states would have broken up ere this; in spite of French support, signs of the Little Entente's disintegration are beginning to appear. A slight push from Mussolini would be enough to topple over the monumental mass of Little Entente treaties. Out of the confusion that would ensue, Italy would be in position to gain international prestige at the expense of France, some of the territory that now belongs to Jugoslavia, and a stake with which to barter for colonies. Under the circumstances, Mussolini has shown commendable restraint in that he continues to bide his time.

There are excellent reasons why he should wait. Italy is not ready for war. Her industrial progress during the last five years has been great, but it has barely enabled her to reestablish the national currency

on a sound basis, and has allowed no accumulation of reserves sufficient to build up large credits abroad. Fascism is strong, but it has not yet converted the Italian people as a whole to acceptance of the Fascist doctrine. The majority of the people still vividly recall the horrors of the World War, and have no wish to see them return. Furthermore, the international situation at present is highly unfavorable to an aggressive Italian move. An eruption in the Balkans would invite Russian and Turkish participation, so that it would be impossible to localize the conflict. France and Great Britain would oppose any move to disrupt the present peace of Europe, and Italy would thus lose the friendship that now binds her to Great Britain. Why should Italy take the initiative when events are playing into her hands? Bulgaria and Hungary, compressed on all sides, are seething with discontent; Bulgarian irregulars are continually fighting with Jugoslavian frontier forces. Suppressed minorities in Jugoslavia and Roumania are stirring uneasily and voicing bitter complaints against the treatment they receive. Greece blocks every effort of Jugoslavia to secure an outlet through Saloniki. Any one of a dozen unsettled major problems in the Balkan states themselves may cause spontaneous combustion. In the meantime, Italy has merely to gather her forces, so that when the time comes she will be ready to use them decisively. Italy is gaining strength far more rapidly than any of her rivals.

Fascism is unlike anything else in the world. True, both Bolshevism and Fascism are anti-democratic, but dictatorship of the proletariat is a far cry from a dictatorship based on the aristocracy of labor. Mussolini has frankly cast aside many of the institutions we cherish, and has replaced them with new forms which cleave to the Fascist concept of nationalism. As with the great social experiment that the Bolsheviki are conducting in the service of mankind, we may find in Fascism virtues that deserve close study. We in the Army are likely to find Columbia a jealous mistress, but surely we may observe virtue without necessarily wanting to marry it.

MAXIM XXI

*When an army carries with it a battering-train,
or large convoys of sick and wounded, it cannot
march by too short a line upon its depots.—
Napoleon's Maxims of War.*

Our Coastwise Shipping

By MAJOR G. F. HUMBERT, C. A. C.

THE coasting trade has been overlooked in song and story; yet since 1859 its fleets have always been larger and more important than the American deep-water commerce.

The coastwise merchant trade has been jealously guarded, by Federal law, against competition ever since 1789, when the first discriminatory tonnage tax was enforced. The Embargo Act of 1808 prohibited domestic commerce to foreign flags, and this edict was renewed in the American Navigation Act of 1817. It remained a firmly established doctrine of maritime policy until the World War compelled its temporary suspension as an emergency measure. The theories of protection and of all trade have been bitterly debated for generations, but in this instance the practice has been eminently successful and the results vastly impressive. Deep-water shipping dwindled and died, but the increase in coastwise sailing has been consistent. It rose in 1926 to 540,500,000 tons valued at \$26,722,000,000, and makes the United States still one of the foremost maritime powers in respect to water activity.

The seacoasts and navigable rivers of the United States by Federal law are divided into six great districts for the purpose of customs and supervision.

The 1st district includes all the seacoasts and navigable rivers between the northern boundary of the state of Maine and the southern boundary of the state of Texas.

The 2d district, the island of Porto Rico.

The 3rd district, the seacoasts and navigable rivers between the southern boundary of the state of California and the northern boundary of the state of Washington.

The 4th district, the Territory of Alaska.

The 5th district, the Territory of Hawaii.

The 6th district, the Great Lakes, their connecting and tributary waters, as far east as the Racquette River in New York State.

To speak of this deep-water shipping as coastwise is misleading in a way. The words convey an impression of dodging from port to port for short distances, whereas the coastwise routes and shipping and size of ships operated thereon of this country are comparable to the international routes and shipping and size of ships operated under the American flag and flags of other nations. A statement of a few of the distances between American ports will illustrate this:

New York to Honolulu via Panama Canal	6702 miles
New York to San Francisco via Panama Canal ...	5262 miles
New York to Portland, Ore ----	5912 miles
New York to Sitka, Alaska	6564 miles

Since the opening of the Panama Canal there has been an enormous increase of our intercoastal shipping. This great increase has been in a water service, which, in the minimum port-to-port mileage, requires a sailing distance of approximately 5000 miles.

The various steamship lines operating on the coasts of the United States, and particularly so in the Atlantic Coast, are in severe competition with the railroads. Most people imagine that the cargoes of these coastwise ships predominately comprise commodities shipped by merchants in the port of origin consigned to merchants in the port of destination, whereas, as a matter of fact, about 70%, by and large, of the cargoes of these vessels operating on regular routes is what is termed rail and water traffic, that is, traffic originating at or destined to a point interior to the ports either of origin or of destination, or both, and interchanged between the railroads and steamships instead of being transported entirely by rail.

Our large coastwise fleets on the Atlantic seaboard not only act as competition to our railroads in rate control to an enormous extent of territory in the Eastern, Middle, and Southern sections of this country, where the major part of our population is located, but also supplements railroad service to the public to an extent not fully appreciated. The railroads traversing this territory, despite their enormous mileage, could not possibly undertake to serve adequately the needs of the communities located throughout such a vast extent of country without continual expensive and annoying delays due to recurring congestion of traffic. This is particularly true in the case of perishable seasonal commodities, all desiring movement at the same time.

Water-borne commerce of the United States during the calendar year 1926 exceeded for the first time the half-billion ton mark. The total as previously stated was 540,500,000 tons with a value of \$26,720,000,000 or about 40 per cent of the tonnage handled by American railroads. Coal and coke totalling 128,580,668 tons were transported in 1926, exceeding the tonnage of any other commodity and constituting 24 per cent of all commodities so carried. Petroleum and its products stood next with 123,922,287 tons. Iron ore ranked third with 68,175,072 tons, practically all of which moved on the Great Lakes.

The coastwise commerce of the Atlantic, Gulf, and Pacific coast ports in 1926 totalled 127,391,166 tons; that of the Great Lakes ports during this period amounted to 120,795,168; commerce on the rivers,

canals, and connecting channels of the United States amounted to 217,000,000 tons.

The Atlantic Deeper Waterways Association was organized in Philadelphia in 1907. It has for its objective "An intra-coastal waterway from Maine to Florida and across the state of Florida to the Gulf." Along the Atlantic seaboard various rivers having their source in the interior seek an outlet to the ocean through various interior bays and sounds. The problem is to connect these rivers, bays, and sounds by artificial channels. These connecting channels need not exceed five or six in number and need not exceed an aggregate length of approximately one hundred miles, excluding Florida. The efforts of this association have been fruitful. Congress has adopted links connecting the Delaware River with Chesapeake Bay, and Elizabeth River, Virginia, with Beaufort Inlet, North Carolina. It is an accepted fact that the railroads have about reached a stage where they must differentiate between high grade freight and the heavy, cumbersome shipments, which were never intended for railroad travel. These heavy, cumbersome shipments must move by water, and the Atlantic Deeper Waterways Association is working with the object in view of an intra-coastal waterway capable of handling coastwise ships. In 1926, traffic on the rivers, canals, and connecting channels of the United States amounted to 217,600,000 tons. This is equal to 16 per cent of the traffic originating on the railways during that year.

A significant feature of recent coastal shipping policy is the tendency of Great Britain to consolidate into large groups, with a single management, under regional systems somewhat akin to the proposition now being advocated for the amalgamation of our own trunkline railroads. A similar policy, though to a lesser extent, has been pursued among our own Pacific coastal lines. On the Atlantic coast we have had for several years like combinations such as The Atlantic, Gulf & West Indies Lines, comprising the Clyde Steamship Company, operating between New York and Baltimore, Wilmington, Charleston, Georgetown, and Jacksonville; the Mallory Steamship Company, operating between New York and Galveston; the New York and Porto Rico Steamship Company, operating between New York and Porto Rico, and the Cuba Mail Steamship Company (Ward Line), operating between New York, Cuba, and Mexico. There is a more or less financial connection between the Atlantic, Gulf & West Indies Lines and the Southern Steamship Company, trading between Philadelphia and Houston, Texas; the Eastern Steamship Corporation, trading between New York and Boston and between Boston and points in Maine, New Brunswick, and Nova Scotia; and the Old Dominion Steamship Company, trading

between New York and Norfolk and Newport News, Virginia. The Atlantic Coast combination naturally signifies that all of the substantial coastwise steamship lines, with the exception of the Merchants and Miners Transportation Company, the Baltimore & Carolina Steamship Company, and such lines as are controlled by railroads, harmoniously cooperate. The Merchants & Miners Transportation Company operates between Boston, Philadelphia, Baltimore, Savannah, and Jacksonville; and the Baltimore & Carolina Steamship Company between Baltimore and Charleston and Miami. The railroad-controlled steamship lines operating on the Atlantic are the New England Steamship Company, trading between New York and New England points; the Southern Pacific Company (Morgan Line), trading between New Orleans and Galveston; and the Ocean Steamship Company, trading between New York and Boston and Savannah. The first-named of these is controlled by the New York, New Haven & Hartford Railroad, the second, by the Southern Pacific Railroad, and the third, by the Central Railroad of Georgia. The foregoing is significant as indicative of the trend of the times in coastwise shipping of what are now the two leading maritime nations of the world. Such combinations, though it may appear so to the uninitiated, cannot, in the very nature of things, ever become monopolies under private control in the transportation of traffic, for the reason that they are subject, in the first place, to the competition of the railroads which parallel them not only in their port to port operations but also in their rail and water operations, and in the second place, to control by the drastic requirements of the Act to Regulate Commerce, as administered by the Interstate Commerce Commission, and the Merchant Marine Act, as administered by the United States Shipping Board.

In the case of railroad-owned lines, it must be borne in mind that they are, by the terms of the Panama Canal Act, prohibited from the use of the Panama Canal, which effectually limits our intercoastal services to vessels entirely free from railroad ownership or control. Besides this, railroad companies cannot own or control any vessels in competition directly or indirectly with their own rail lines, except by special permission of the Interstate Commerce Commission after demonstration that it is to the public interest that they should do so, and only then on condition that in all their operations, including their port to port traffic, they must be entirely subject to the requirements of the Act to Regulate Commerce.

Steamship companies doing a general public business have, from time immemorial, been adjudged by the courts to be common carriers, with all that this implies in liability to the public for loss of and

damage to cargoes, notwithstanding the fact that they enjoy no franchise for exclusive operation in any particular territory granted by any legislature, such as is accorded every railroad company. All routes of existing coastwise steamship companies are free of access to any competitor without legislative grant or restriction, and sailboats in particular avail themselves of this opportunity in these trades to an extent not generally recognized, particularly in the carriage of commodities of low value moving in cargo lots. These sail vessels are practically tramps and do not operate on any particular route, plying here and there in opposition to the coastwise liners wherever cargo may be offering. While it is true that most of the routes in our coastwise services are each served by but one steamship line between two or more coastal cities, the fact that this has existed for many years is pretty conclusive proof of the excellent and satisfactory service accorded these communities.

As a rule, freight carried by the Atlantic coast lines destined to and from southern territory can make as good time in transit as when carried all rail for the obvious reason that with transportation by water there are few stoppages and no shunting to sidings to make way for passenger trains. The element of marine insurance, however, must be taken into account on water carriage, which does not apply to land transportation.

Solicitation for traffic between the various steamship companies operating to and from the various Atlantic coast ports is exceedingly keen. For traffic to and from New England, the New York lines are in active competition with the New England lines to and from Boston and other New England ports, particularly for the industrial output of New England territory semi-distant from New York and Boston. On the other hand, the lines in New York are in acute competition with the lines from Baltimore and Philadelphia for the traffic originating in or destined to the territory of the Middle Atlantic States and the traffic originating in or destined to the territory of the whole Southern and Southeastern section of the country.

The recent expansion of our overseas shipping and the policy of the United States Shipping Board in instituting services from the South Atlantic ports direct to Europe has somewhat diminished the cargoes formerly carried by our larger coastwise liners. Before the inauguration of these South Atlantic port overseas line services, cotton, tobacco, and naval stores were in a large measure carried by the coastwise lines from the South Atlantic ports to Baltimore, Philadelphia, New York, and Boston, and there transshipped to the large fast overseas liners, whereas now most of these commodities are shipped direct from the South Atlantic ports to European ports.

Such of this traffic as still continues to move from the Southern ports to the Northern Atlantic ports by coastwise liners for transshipment thence by the large fast ocean liners is due to the greater frequency of overseas sailings from the Northern ports.

One of the most complex problems confronting the executives of the coastwise lines is the lack of adequate terminal facilities at such ports as New York, so transcendently the leading port of the country and, in fact, the greatest port in the world. The coastwise carriers suffer from this much more so than the international carriers for the reason that the sailings and arrivals of the former are so much more frequent. This problem is particularly acute in the case of inbound consignments, which are not removed from piers by consignees with sufficient celerity to provide accommodations for each succeeding arrival. The congestion resulting from this adds enormously to the terminal costs. In this connection it must be remembered that our coastwise combination freight and passenger steamers, which comprise the bulk of these liners, arrive and depart with clockwork precision, almost as much so as a ferry line.

Whatever apprehension we may have in regard to a decline in our overseas shipping, there need never be any such fears in regard to our coastwise merchant marine so long as it continues to be exclusively confined to vessels under the American flag. From the inception of our nation we have always had a large coastwise shipping, providing a large reservoir of trained seamen to draw upon in times of stress, and this condition will be accelerated in proportion as the population, and consequent trade and commerce of our country, increases. This state of affairs applies equally to the commercial completement of operatives transacting the shore operations of our coastwise commerce.

Our coastwise shipping comprises liners, including freight steamers, combination freight and passenger steamers, industrial carriers transporting bulk cargoes of coal, sulphur, etc., oil tankers, and sailing vessels. Until the sulphur beds of Louisiana and Texas and the coal supply of our country adjacent to the outer ports are exhausted, shipping will be necessary to transport large cargoes of these commodities to our important industrial centers. In this connection it is interesting to note that there is not a ton of coal or a pound of iron produced in all of the six New England states where are located a very large, if not preponderant, proportion of the industrial plants producing for our whole domestic market. To these coastwise liners should perhaps be added the steamship services between the United States ports and nearby Canadian, West Indies, Mexican, and Central American ports, carrying miscellaneous cargoes, oil, coal, ore, etc., which, it may safely be presumed, despite the competition of foreign

shipping interests, will continue to be operated under the American flag.

Owing to the controlling necessity for the construction of overseas cargo carriers during the War, no new construction of our coastwise fleets could be undertaken during that period, and during the subsequent disturbed condition of affairs resulting from the War, very little, until within the past year or so, has been turned out from our shipyards. Most of the fleets of these coastwise liners in the meantime have, in the natural course of events, been gradually depreciating, and it must inevitably result from this that considerable new construction of such vessels will have to be undertaken in the course of the next few years. In view of the enormous glut in the market of cargo carriers all over the world, this should be a somewhat refreshing consolation to our American shipbuilders. Of the fourteen steamers of over 1000 tons constructed in American shipyards during the year 1923, all but one were designed for coastwise service, seven of these being combination freight and passenger vessels and six cargo carriers.

While it is impossible to prove this by statistics, yet I feel safe in asserting that safety of life and freedom from accident on board our coastwise vessels are as great if not greater than in the streets of any of our great cities such as New York.

Not only are all of the officers of our coastwise liners American citizens, as is required by law, but, as a matter of fact, almost all of the officers and petty officers are American born, and many of them have, in their earlier years, served in sailing vessels. They are, as a rule, men of exceptionally high character, general intelligence, and sound common sense.

On our coastwise ships today all food supplied to crews is much superior, both in quality and quantity, than the average workman ashore can afford to indulge in for himself and family, this being found necessary to attract and hold competent crews; and the scale of wage for both officers and crews compares favorably with the compensation for similar service ashore, despite the fact that subsistence is furnished afloat and not ashore.

No industry or branch of commerce in this country is regulated or controlled to the same extent in the aggregate as the steamship companies engaged in coastwise business. In regard to the whole of the rail and water traffic transported by them they are subject to the Act to Regulate Commerce; and as they have to report their earnings on their port to port traffic to the Interstate Commerce Commission this practically means that they are about as much subject to the jurisdiction of the Commission as any railroad. They must also conform to the requirements of the Shipping Board, the Merchant Marine Act, and the

onerous burdens of the Seaman's Act; likewise, the national statutes comprising the Navigation Laws and the rules of the Supervising Inspectors of Steamboats made pursuant thereto.

When, in 1914, Great Britain declared war against Germany, all of the merchant ships of Great Britain were commandeered by the Government of that country and withdrawn from world service for the individual needs of Great Britain, either commercial or military. The German merchant ships, in turn, were either interned in Germany or in foreign ports by the combined navies of Great Britain and her allies. As at that time a very large preponderance of the world's available merchant ships were under the flags of either Great Britain or Germany, and the British Government also chartered a large part of the remaining merchant ships of other nations, including American overseas ships, the merchant ships available for overseas commercial purposes of neutral nations were almost negligible. Had it not been that many of the larger vessels then operating in the coastwise fleets of the United States were capable of being reconditioned for operation overseas for the exportation and importation of American commerce for the period intervening between 1914 and 1917, when we entered the war, our purely commercial export and import trade not connected with the war would have been at a standstill, with all that this implied to our traders who had assiduously been building up our foreign commerce in the years preceding the war. Our coastwise shipping in this emergency was a commercial lifesaver in this respect to the United States. This was an impressive object lesson vividly brought home to us of the wisdom of the policy of the United States in restricting its coastwise shipping to vessels flying the American flag. Not only so, but our large coastwise fleets then in existence had been the nursery for the crews and officers which were required to man our expanded Merchant Marine when we were once in the war. By law, all the officers of our coastwise fleets, both deck and engineers, must be American citizens.

It was the personnel of the shipyards in existence before 1914 who formed the nucleus of trained men who whipped into shape the raw human material required to man the mushroom shipyards improvised during the war, which served as the greatest demonstration to the world of our marvelous constructive industrial capacity. Our coastwise business being by law confined to vessels under the American flag, the vessels in this trade are likewise compelled to be constructed and repaired in American shipyards, and it was largely upon the construction and repairs of the great volume of our coastwise shipping that the shipyards in existence before the war relied for their maintenance.



COLONEL FRANK K. FERGUSSON

Commandant Coast Artillery School, March 30, 1913—September 11, 1918

EDITORIAL

Promotion and Elimination

LIKE all the rest of the world, the personnel of the Army may be divided into two main classes: the satisfied and the dissatisfied. In no particular phase of our complicated existence of today is there entire unanimity of thought, but it is a general rule that the dissatisfied constitute a minority. If this be not the case, some change results whereby the groups are realigned and dissatisfaction is thrust upon the minority. But, in any case, the dissatisfied always become vocal.

Recently, a survey of the existing and prospective situation in regard to promotion in the Army indicated that the majority was dissatisfied and that a change was necessary. To determine the true situation and to determine a remedy, if one should be found necessary, local boards of officers were convened throughout the Army, to which individual officers were invited to present their views. These boards considered all phases of promotion and elimination, added their own ideas to those of the individuals appearing before them, and forwarded their findings to a board of general officers, which, in turn, studied the reports of the local boards and submitted its recommendations to Congress in the form of a bill intended to alleviate the existing situation. In all these reports, the needs of the individual were important factors, but the interests of the Army as a whole were dominant. Presumably dissatisfaction would again fall upon a minority.

Since the publication of the findings of the general board, the service weeklies have been called upon to devote much valuable space to letters purporting to come from officers who object to the provisions of the proposed bill. These letters are so numerous that one would be inclined to believe their writers represented a majority in the Army unless one realized that the satisfied seldom have cause for argument. Moreover, despite the camouflage of anonymity, the personal—and usually selfish—interest is evident in almost every letter. Aside from a desire to see their letters in print, the writers display three more or less common characteristics: They place the individual above the organization; they show an unfortunate lack of loyalty; and they are inconsistent in their demands.

In almost every letter appear two hypothetical individuals known as A and B. One has something the other claims—but what of it?

All life is based on the greater good to the greater number, and life is full of individual hardships. A and B are merely units in a system. If the good of the system impose a hardship upon one to the advantage of the other, it behooves the unfortunate one to accept his lot in the interest of harmony and teamwork. The pendulum may swing the other way in the course of time.

Continued opposition to an adopted policy constitutes lack of loyalty. Every individual officer in the Army had an opportunity of expressing his views before any recommendations were made. These views, in so far as they could be coordinated, were presented to the general board as representing the opinion of the Army. The general board took such action as the interests of the Army seemed, in its opinion, to demand. We must assume the good faith of the general board—and who are we to question its good judgment?

The matter of inconsistency is serious. Until we know what we want, we shall get—and deserve—nothing. When the question first came up, the demand was for promotion. The general board found a method of providing for promotion, and immediately came a cry for security. The two do not go together. If we want security, we must accept slow promotion. We must, perhaps, remain behind inferior men that we may be sure of retaining our places ahead of superior men. If we want promotion we must accept lack of security. We must risk being jumped or eliminated in order that we may have the opportunity of jumping others or having others eliminated to make room for us. We cannot have both, and we are likely to have neither unless we decide what we do want.

The bill prepared by the general board is not perfect. Its proponents will be the first to admit that. The Secretary of War found features he could not approve. The members of the JOURNAL staff objected—at the proper time and place—to some of the provisions that were finally adopted, but we feel that the time for objections has passed. Who can say that the proposed bill will not, on the whole, benefit the Army? It would be well, perhaps, to trust more in the judgment of Congress and to adopt temporarily a motto to be found in many a Chamber of Commerce: "If you can't boost, don't knock."

"Dawn"

A film which has recently produced considerable agitation in official circles is one bearing the title "Dawn." The story told in the picture is that of the later life and the death of Nurse Cavell. The film received

official disapproval in England, and Sir Austen Chamberlain refused to attend a private view of the picture.

Nurse Cavell gallantly played her part in the great war drama and as gallantly made her exit. She was executed—as other women have been executed—according to the demands of military law, but her death was made the subject of an extraordinary amount of propaganda to intensify allied feeling against the enemy. Under the circumstances, dramatization of the story of Nurse Cavell, even at this late date, can only serve to provoke an enmity which should no longer be permitted to continue. Regardless of its historical accuracy, it would perhaps have been better had the film not been brought out, but, having appeared, the wisdom of advertising it with the stamp of official disapproval may well be questioned.

The S-4

The Navy Board of Inquiry on the loss of the submarine *S-4* found a divided responsibility for that disaster. In the opinion of the Board, the collision between the *S-4* and the *Paulding* was caused by the failure of the *S-4* to take proper action to clear the *Paulding* when that vessel changed its course in an effort to avoid collision and by failure of the *Paulding* to sight and recognize the submarine until too late to avoid collision. More specifically, the commanding officer of the submarine is charged with a lack of vigilance or with poor observations, and the destroyer is charged with the maintenance of an inefficient look-out. The Board therefore found that the responsibility for the accident lay jointly and personally with the late Lieutenant Commander R. K. Jones, of the *S-4*, and Lieutenant Commander J. S. Bayliss, of the *Paulding*.

The Chief of the Bureau of Navigation very properly took exception to this finding. As to the division of responsibility, the International Rules of the Road for the Prevention of Collisions at Sea required the submarine to keep clear of the *Paulding*, and it is reasonable to assume that the submarine was much less visible to the destroyer than the destroyer was to the submarine. As to the personal responsibility of the late Lieutenant Commander Jones, there is no direct testimony. He was presumably in the exercise of his command, but no one can definitely so state. Any one of a number of causes might have served temporarily to have removed him from actual command at the time.

Much as the collision is to be deplored, no stigma should be attached to the officers involved until all the facts be known, and in the case of Lieutenant Commander Jones these will probably never be positively ascertained.

Dress Uniform

If we are to accept as authentic a news item which recently appeared in one of the service weeklies, the Army is about to have a dress uniform. The paper has a reputation for accuracy in reporting Army news, so we must be prepared to accept as possible—even probable—a uniform somewhat according to the specifications it gave:

While the final colorings which will be decided upon are of course unknown at present, it is indicated that the new uniform will probably be of a blue shade and follow these general lines:

Coat: Single-breasted with standing collar, cut as present service coat but without pockets, and to fasten with nine gold buttons showing between Sam Browne belt and collar. To be worn with gold shoulder knots and insignia of branch, rank and regiment, if any, on the cuffs. The collar to be trimmed with gold braid for lieutenants and captains, oak leaves for field officers, and insignia of rank for general officers. General Staff Officers, aides to the President, and military attaches alone to wear aiguillettes.

Belt: For general officers to be a combined shoulder and waist sash of golden silk. For all other officers a Sam Browne belt, faced with silk, of the color or colors of branch or arm of service, and trimmed with gold braid.

Trousers: Same color as coat, trimmed with one narrow gold stripe for lieutenants and captains, two for field officers, and one wide strip for general officers.

Cap: Similar to that worn by French; color to match uniform, black patent leather visor, and band trimmed with insignia of rank same as collar.

Breeches: Same as trousers.

Boots: Black, with silver spurs and chains.

We have consistently advocated a return to a dress uniform for wear in the evenings and on special occasions, but, without having consulted a military tailor, we have a slight suspicion that most of us will continue to sit around the house in the same old O. D's.

MAXIM XIX

The transition from the defensive to the offensive is one of the most delicate operations in war.
—Napoleon's Maxims of War.

PROFESSIONAL NOTES

Coat of Arms for the Harbor Defenses of Eastern New York

Shield: Ermine on a chevron *vert* a mine case between two Engineer castles *argent*.

Crest: On a wreath of the colors a dexter arm in armor embowed proper charged with a mullet *gules* grasping in the naked hand a sword *argent* hilted *or*.

Motto: *Sic Vis Pacem, Para Bellum.*

Fort Totten was originally the site of the Engineer School of Application, later the Coast Artillery School of Submarine Defense. The Chevron in green, the school color, with its charges, shows its history. It is now the seat of the Artillery District shown by the crest, the star indicating a general officer, the arm with sword the power of command.

Classification of Officers of the C. A. C.

1926

<i>Rank</i>	<i>Superior</i>	<i>Above Average</i>	<i>Average</i>	<i>Below Average</i>	<i>Inferior</i>	<i>Totals</i>
Colonel	8	27	22	0	0	57
Lt. Colonel	4	27	24	0	0	55
Major	15	112	95	1	0	223
Captain	2	108	164	1	0	275
1st Lieutenant	0	61	164	0	0	225
2d Lieutenant	0	15	127	0	0	142
Totals	29	350	596	2	0	977

Not classified, 29.

1927

<i>Rank</i>	<i>Superior</i>	<i>Above Average</i>	<i>Average</i>	<i>Below Average</i>	<i>Inferior</i>	<i>Totals</i>
Colonel	9	25	22	0	0	56
Lt. Colonel	7	27	24	0	0	58
Major	11	123	89	1	0	224
Captain	2	118	140	1	0	261
1st Lieutenant	0	77	161	0	0	238
2d Lieutenant	0	23	125	0	0	148
Totals	29	393	561	2	0	985

Not classified, 31

Only a casual perusal of these tables is necessary to convince one that rating officers are particularly severe when reporting on Lieutenants. Careful examination of individual efficiency reports shows a hesitancy to rate a lieutenant "above average" or "superior" although under "remarks" the rating officer often uses most flattering phrases which, if true, indicate that the officer being reported upon is performing his task in a superior manner. One commanding officer recently remarked when making up the efficiency report of a Lieutenant, "If this young man were a Captain I would rate him superior." Why cannot a Lieutenant be a superior Lieutenant?

Recently, in another case the battery commander rated a Lieutenant "Superior" in a few qualifications. This gave the next higher commander cause for the following remark: "These ratings are too high *since they leave no room for improvement.*" Of course such a remark has no weight with the classification officer, still one wonders why a Lieutenant cannot be rated on the job he is doing and on the same basis as are officers of other ranks. Let's give the Lieutenants a chance!

German Long Range Heavy Artillery in the World War

The Austrian *Wherzeitung* of December 16, 1927, contains a synopsis of a lecture delivered by Major Breitung of the former German army at the Artillery and Navy Club of the Artillery League of Tyrol-Innsbruck on the subject of the development of the construction and operation of the extreme long-range heavy German artillery on the West front, which he commanded in the World War.

The lecturer explained in detail the development of the heavy artillery, beginning with the 15-cm. field howitzer to the 30.5-cm. Austrian mortar and the 32 and 42-cm. cannon. The greatest interest was taken by his hearers in his description of the "Paris gun," the long-range gun that placed Paris under fire on March 25, 1918. Following is an extract from Major Breitung's account of this and other extreme long-range guns used by the Germans.

The heavy artillery, made mobile by motorization, developed itself from an embarrassment to a relief—a liability to an asset—of the supreme army leadership. The very heaviest railway guns that had heretofore served only for *renanche* firing were thenceforth applied for action within the range of major tactical fighting transactions. To conform to this, battery emplacements were laid out on the army fronts and connected with one another by a railway system of their own, for the construction of which 4000 men were detailed. A very efficient system of screening and camouflage kept their work from observation of enemy fliers. To assist in this, work was carried on in construction of short sections of railways at various places distant from the lines to be used by the heavy guns. After very careful preparation, the heaviest artillery established itself in the great combats of early 1918 as a portable and tactically available special arm. Beginning with 220 batteries at the outset of the campaign, the number rose to 1600, with one hundred different kinds of guns and methods of firing, and using them. The long-range guns of the war navy (for instance, the 38-cm. guns with a range of 37 kilometers, weight of projectile 800 kilograms, barrel length 17 meters,) fired on masses of assembled troops, depot positions, ammunition magazines, railway dumping stations, etc., that had been identified and located by a far extended system of air observation. Captured officers and men gave evidence of the demoralizing and destructive effect of this fire of heavy projectiles

that came down from an elevation of from 3000 to 4000 meters and, with the Austrian 30.5-cm. mortar, 6000 meters—exceeding the height of Mont Blanc by over 1000 meters. The elevation of the 38-cm. guns attained the enormous height of 16,000 meters. Dunkirk was placed under fire by a gun of this kind for two and a half years.

It is self-evident that these firing activities were preceded by the most exact observations and reconnaissances, that sound and light survey troops were kept in constant activity, that enemy observations and reconnaissances were prevented and obstructed by the most careful screening and camouflage, by covering entire zones with artificial fogs and mists during light days. A far-extended telephone network combined the attached escort batteries which were required to fire simultaneously to the second of time with the fire of the great guns in order to prevent the enemy from fixing their location.

Meanwhile German gun manufacturers and ballistic experts were engaged in studies of methods of increasing still further the range of these heavy guns. The tests that were made under direction of ballistic and construction experts, Professor Ranzenberger and Engineer Eberhardt of the Vienna Technical Military Academy, established the necessity of reducing the caliber of the 38-cm. gun to 21-cm. by placing within it a tube of that caliber. The barrel was extended to 34 meters by means of a 6-meter smooth-bore attachment for more perfect utilization of the powder gases. The weight of projectile fired from the remodeled gun was approximately 150 kilograms and was provided with base and point fuzes. The cartridge that was inserted in the 6-meter loading chamber weighed about 300 kilograms and gave the projectile an initial velocity of 1800 meter-seconds (5905 foot-seconds)—more than double the average velocity of the infantry rifle bullet. The height of the muzzle of the gun barrel raised to a position ready for firing was 34 meters. Time of flight of projectile, 3 minutes. The vertical vibration of the long barrel was one meter above and below its position of rest and was kept up for one minute notwithstanding very complicated balancing and stabilizing appliances.

In experiments along the German coast the impact points of projectiles gave 132 kilometer ranges. This demonstrated that at an altitude of over four kilometers the projectile passed through space where atmospheric resistance was negligible and that in consequence the range was increased. This solved the problem and the Parisians were treated to an unpleasant surprise. In calculating the various elements of fire, rotation and curvature of the earth had to be taken into account. Paris was fired upon from three different places and with a total of about 300 rounds which were aimed at railway stations and war working establishments.

The French did not succeed, in spite of intensive efforts in reconnoitering, in establishing the location of the firing points of the gun. But the German artillery commander did succeed in dismantling and removing to a safe distance the gigantic guns in time to prevent their capture by the French. It required two days to take the guns down and a whole week to set them up again in position in readiness for firing.—G. R.

New Army Antiaircraft Gun

The War Department has adopted, as standard for manufacture, a new 3-inch antiaircraft gun and mobile mount. The gun is 50-calibers in length and is made

up of two parts, an outer tube and an inner removable liner. The removable liner represents a marked advance in gun construction, as it does away with the necessity of sending a worn-out gun to an arsenal for tubing.

The gun fired a standard 3-inch projectile at a muzzle velocity of 2600 feet per second. The vertical range is about 5000 yards and the maximum horizontal range 11,000 yards. The gun is equipped with a semiautomatic breech mechanism which closes when the round is pushed home and opens automatically and ejects the disc when the gun is fired. It may be fired at the rate of about 25 shots per minute. The indirect method of fire control is used, in which the firing data is transmitted continuously by electrical means from a central station computer to the gun, and the gunners have only to keep the gun laid on the future predicted position of the target by matching pointers.—*Army and Navy Register*.

Aircraft in Submarines

The Sunday newspapers on New Year's Day went gay on what they regarded as the surprise revelation of a great secret, that officers of the Fleet Air Arm and naval observer officers, when appointed to submarine carrying aircraft, are to be eligible for an allowance of 2s a day while so employed. It is ridiculous to suppose there was anything accidental about the publication of an Order in Council authorizing this payment. Sooner or later, the fact that trials with aircraft in submarines had been carried out for some time was bound to be mentioned officially, and the precise form was immaterial. In the case of the catapult apparatus for launching aircraft into flight from ships, it was left for the First Lord to make the announcement, which he did in his Memorandum two years ago. That announcement was not made until a certain measure of success had been achieved, and if the same degree of progress had been made with aircraft in submarines, it would be a matter of considerable satisfaction. But the question is obviously more complicated and difficult.

Progress towards a submarine seaplane has been going on ever since the war from two directions. On the one hand, submarines have been increasing in size and capacity, until in the case of the United States "V" 4, which was launched on November 10, the displacement has reached 2890 tons; and the French have in hand a vessel of 3000 tons. On the other hand, great progress has been made in developing light airplanes, as the success of the "Moth" type shows. What was claimed to be the first machine built for use in a submarine was completed in France over a year ago, and on February 1, 1927, it flew from the Besson works, Meulan-on-Seine, where it was built, to Suresnes, for despatch to Brest. This machine was a two-seater, with a Salmson engine of 120-horsepower, and having folding wings, so that it could be stowed in a water-tight cylinder in the submarine when not in use. Experiments have also been carried on for some time in the United States. It was not to be expected that our own authorities would lag behind in so important a matter.—*The Army, Navy and Air Force Gazette*.

Combat Order for Harbor Defenses

In preparing for the problems which the officers of one of our Harbor Defenses may be called upon to solve during the coming Target Practice Season and War Condition Period, considering the probability of conducting Joint Exercises with

the Navy, it was found desirable to give a short course of instruction in the subject of Combat Orders. As neither *Field Service Regulations* nor *Combat Orders, G. S. S.* gives a form for an order for the defense of a harbor, it was found desirable to originate a form particularly applicable to harbor defense. This form is given below. While it is not complete, since field orders for a Harbor Defense are likely to be more complicated than those of any other unit of the same size and since each Harbor Defense has its local problems, it is believed that it may be a step in the right direction. This form has been compiled from data found in *Field Service Regulations, Combat Orders, G. S. S.*, and War Department mimeographs.

A FORM OF ORDER FOR DEFENSE OF A HARBOR

Title

Place

Date and Hour

FIELD ORDERS

No.

MAPS:

1. *a.* Information of the enemy—strength, composition, mission. Refer to G-2 Report for details.
- b.* Information of friendly troops—general position and mission of other troops of the subsector command; troops within supporting distance; plan of higher unit; support to be given by higher unit and by the Navy.
2. *a.* Decision of commander—designate attached units, give plan of defensive action.
- b.* Boundaries of sectors occupied by the sector or subsector, the Harbor Defenses, and subordinate units.
3. *a.* Instructions for fixed Harbor Defense Artillery (give numbered subparagraph for each groupment or Fort Command). Reference may be made to Artillery Annex or to the General Seaward Defense Plans. Give normal and contingent zones.
- b.* Instructions for Railway Artillery—Instructions as in *a.*
- c.* Instructions for other mobile artillery units.—Instructions as in *a.*, and assignment to duties in support of infantry units in the beach defense; special missions.
- d.* Instructions for Searchlights.—Assignment of normal and contingent areas. Duties of pilot, searching and covering lights. (Reference may be made to General Seaward Defense plans.
- e.* Instructions to terrestrial observation stations; assignments to water areas; character of information desired.
- f.* Instructions to Air Corps.
 - (1) Battle reconnaissance and observation missions, giving area within which observation is to be carried out; character of information desired; special signals to be used.
 - (2) Balloon observation to be furnished.
- g.* Instructions to Inshore Patrol Boats. Give area within which observation is to be carried out, character of information desired, special signals and lights to be used. Refer to Joint Army and Navy Operating Plan.
- h.* Instructions to Radio Compass Stations.
- i.* Instruction to Mine Commands. Refer to Mine Defense Plans.
- k.* Land Defense: For details see Land Defense Annex. Troops.
- l.* Antiaircraft Defense: For details see Antiaircraft Annex. Troops.

- x. Instructions applicable to entire command which do not belong in another subparagraph.
 - (1) Use of gas and smoke.
 - (2) Instructions for gas defense.
 - (3) Time of beginning night operations.
 - (4) Instructions relative to gathering of information.
 - (5) Instructions regarding secrecy.
- 4. Administrative details. Refer to administrative order by number if issued. If none issued, give such instructions regarding supply, evacuation, traffic, trains, as may be necessary.
- 5. a. Signal communication—refer to annex if necessary.
- b. Command Posts:
 - (1) Give location for next higher units.
 - (2) Prescribe location for H. D. groupments, forts.

(Authentication)

Signature_____

Annexes:

Distribution:

The Influence of Mechanization of Armies on the Duration of Wars

From an article in the January 25, 1928, *Militär-Wochenblatt* by Major Dr. Oscar Regele, former Austrian Army.

When machine guns were first introduced as an army equipment one was told how war could endure for a few weeks only on account of the loss of masses due to their use. Similar predictions were made for naval war when U-boats were first brought out. We know today that the introduction of neither of these two war machines has caused any reduction of the duration of wars. The continually increasing circle of mechanization of war equipment has again raised the question of their influence on the duration of future wars and we are faced with acceptance of the assumption that wars will be shortened as a consequence. Experience has shown that heretofore predictions concerning the probable duration of coming wars were seldom realized. A well-known exception is the elder Moltke's declaration that the next war would be a long one.

Duration of a war depends upon very many contingencies, but of not a single one of them can it be said that the kinds of war machines employed have exercised any influence on its duration. It is the relative strength of the forces engaged, the external political situation, the mutual defensive systems and methods of conducting the war, the skill of commanders-in-chief, the geographical conditions of resistance of the theaters of the war operations, and innumerable other items that are the deciding factors.

In the first place, we must start out at best with the assumption that the opponents are equally equipped and matched in strength—any other basis of comparison would be excluded if one presumed to set up prognostications in regard to the duration of any certain future war.

Duration of war is essentially dependent upon the personal and material achievements and capabilities of the parties engaged. It is not only the supply on hand of men, animals, and raw material, but the possibility of their current replacement as they are absorbed, that enters into the reckoning. Highly developed sanitary means and skilful medical practice quickly replace wounded men and return them to the ranks, and the achieving capacity of war industries, inclusive

of maintenance of supplies of raw materials, replaces machines with incredible rapidity. War will therefore last longer as facilities for replacement of men, animals, and war appliances are improved. The World War has thrown a glaring light on this feature of war because it was the replacement question that proved, in the end, to be the deciding factor of the war's duration.

The replacement question gains special importance with mechanized armies. The war technique that takes the foreground in such situations withdraws many thousands of fighting individuals who make up the great army of factory workers. The army and its personnel replacement resources are therefore correspondingly restricted. But the number of the machines, tanks, and motor vehicles is also practically circumscribed, not only by the possibility of their endurance in service by experts who can keep them technically in continuous serviceable condition but also by replacement possibilities for those destroyed. For this reason the assertion that mechanized (tank and motored) armies can be only relatively small armies is unquestionably correct and the principal question confronting such small armies is whether or not and how rapidly the machines destroyed and damaged in combat can be replaced.

We know from the history of naval wars, wars carried on with large machines (war vessels), that usually a single application of these machines decides the war on the sea. The defeated party can not possibly replace his loss of vessels in sufficient time to prevent the more powerful victor from exploiting his success and deciding the issue. Naval warfare endures for a longer time only when it is carried on in combination with operations on land and the fleets are held out until the time of decision has arrived.

Similar conditions must in future prevail with air fleets. A part of the air fleet fights in continuous combination with the ground and sea fighting forces and has its losses replaced currently. But it will be otherwise when we come to the fighting of air forces in closed order, which we have not yet attained nor experienced. In that case, the results will be the same as has already been stated for naval sea warfare. If the fleets are held back the war naturally lasts longer.

Transferring these occurrences to the war of mechanized forces, that is, to the "land fleets," we have, as a result, that here also the war will have a speedy end if one of the tank fleets is rendered unfit for fighting and the victor throws his redoubled force into the scale. Improvised land or air fleets are no more possible on land than they are on the sea. Further reflection shows:

The circumstance that in future the entire force of the people will, without exception, be put in service for war, and that material preparations for the struggle will be made for its longest possible duration, seems to indicate a long duration of the war of the future which will also undoubtedly become a war of masses as was the World War, because the day of locally circumscribed wars between single states is a thing of the past.

Even though mechanized parts of an army may in general tend to have an accelerating effect on war operations, one may expect that when the mechanized elements are exhausted, resort will again be had to the older plainly armed forces which will contend with each other by the old methods. Then we will naturally revert to longer wars. We may also have the situation such that the most modern war machines are neutralized by their counterparts to such an extent that other fighting means are able to assert themselves. At any rate, the claim that land fleets will undoubtedly reduce the duration of war is substantiated in part only.

If a state decides to put its machines into action in close order at the very beginning then wars may, under certain circumstances, be ended much sooner than was formerly possible. A decisive victory with tanks on land and planes in the air may, in fact, end the war in a few days when the defeated opponent is unable to recover at once. The practical methods of the air war and the possibility of traversing great distances by mechanical forces make large sections and in many cases the entire lands of the warring nations the theater of war operations. That also tends to shorten wars.

From what has been said there results the conclusion that it is unusually difficult to forecast, even approximately, a correct vision of future war duration. When we take into consideration two other influences in addition to those above alluded to that can be brought in and must not be underestimated, such as international socialistic movements, whose aims and purposes run counter to the fundamentals of national wars and may interject exterior wars and in many cases even civil wars into the situation, we must admit that the final outcome is subject to complications.

The machine fleets of the future can bring a war to an end in a much shorter time than has been possible heretofore, yet wars of extensive duration have not thereby been made impossible.—G. R.

United States Sea Party

There is evidently a large body of opinion in the United States to whom the idea of obtaining the so-called "freedom of the seas," that is, the power of trading at all times with any country with whom they are not at war, regardless of the rights of blockade, is not acceptable. A conference at St. Louis a few days ago urged that there should be a solemn pronouncement by the President that when, in the judgment of the Government, the case arises of a nation going to war in violation of its previously given pledge to take its disputes to an international tribunal, the United States should not insist upon the continuance of her right of trade with the covenant-breaking State. Urged by an influential body, and supported by Mr. Newton D. Baker, late Secretary for War, this resolution is significant.

It is the view of a trained observer recently in the United States that how much of the proposed new shipbuilding programme is carried out will depend upon the attitude of other nations, particularly ourselves. They will take an opportunity to shift the responsibility on to us if reflections are made upon their motives; if it is suggested, for example, that a large fleet, while an absolute necessity to this country, is an expensive luxury for the United States. This is tantamount to an admission that the Washington Government is uncertain of itself in this matter, and is open to be swayed by whim or caprice. The only possible attitude for the British Government in such circumstances is to renew the disavowal made by Sir Austen Chamberlain in the House of Commons on July 27 last that we have any desire to dictate the cruiser policy of other Powers. Nothing they may do can alter the necessity imposed upon us of providing for the defence of our seaborne trade, by which we live. Conversely, it is for the United States Government to determine what its own needs are.—*The Army, Navy and Air Force Gazette.*

R. O. T. C. Camps

Facilities for training 7200 Reserve Officers' Training Corps students this year were authorized by the War Department, actual attendance at last year's camps being 6382. Third or local corps area is allotted 1083.

Of the 108,000 students enrolled in schools and colleges, those who complete their junior year are eligible for camp training and the allotment of 7200 will be selected from these.—*Washington Post*.

Vanishing American Soldiery

Theoretically nothing could be more unsentimental than an army—yet the War Department of the United States has been asked to retain “for sentimental reasons” twenty-one of the Indian scouts who were enlisted in its services many years ago. Time and changing methods of warfare have destroyed the usefulness of these 100 per cent Americans. The presence of an ambushed enemy no longer needs to be ferreted out by skilled followers of an indistinct trail. The noise of a barrage does the work that the red man was once able to do better than any one else. Today a single airplane is worth a regiment of Indians, both for observation and courier service.

Yet at Fort Huachuca, Arizona, two native corporals and nineteen privates all of them now beyond the ordinary age of military service, are still kept in uniform, doing ordinary work around the barracks now that their old and romantic occupation is gone. It is reported by the commandant of the post that they are “well disciplined, well trained, and perform their work very efficiently.” The commanding general of the 8th Corps Area recommends that they be continued in the service because of “sentimental considerations and concerns of historical significance.” And the descendants of a people which once got little sleep for fear of hostile warwhoops and imminent tomahawks will devoutly trust that his recommendation will be approved.—*New York Herald Tribune*.

A New Safety Fuel

Both France and England are showing the greatest interest in a new safety fuel for internal combustion engines, developed by a Frenchman. Recently an airplane was driven from Paris to London, its tanks filled with the new fuel. A sample drawn at the British airport extinguished a match instead of being ignited by it. Poured upon a red-hot stove, it gave off a puff of white vapor, but did not catch fire. A piece of blotting paper, saturated with the fuel, burned slowly, but did not flare up with explosive violence, like gasoline.

The French Air Union plans to utilize the new fuel in all planes operated on the London-Paris route after February 1. The British air ministry, is investigating its possibilities and practicabilities with the view of adopting it as standard for all military planes.—*Washington Post*.

The Field Artillery Role in Mechanization

The field artillery will continue in an important role in spite of any steps toward mechanization. This is the view revealed by the study on employment of mechanized units on the battlefield, prepared by officers of the War Department,

General Staff. New problems would be faced in view of the much greater speed with which a mechanized unit would move on the battlefield as compared with the rate of movement which determined the present method of artillery support. The movement in attack would be at least four times as fast as in the World War.

Operation of protective and accompanying fire of the supporting artillery would be involved. Following accepted principles of organization this would require that the mechanized unit contain artillery. Such artillery would be able to give a close support, operate under the command of the attack commander, go into position with rapidity, and move with the speed of the other elements of the mechanized unit.

The study indicates the utility of the present models of the 75-mm. and 4.7-inch guns, self-propelled, with shield sufficient to protect against small arms and shell fragments as a part of a mechanized unit.

Armored light cars for distant reconnaissance, rapid communication, and command purposes also would be a part of the mechanized unit.

Mechanization would include engineer troops to provide for quick repair of roads and strengthening of bridges. They would require rapid transportation, cross-country and road mobility, with handy portable bridge equipment.

The general study takes into consideration a mass of data on commercial development and experimental work throughout the world. Much of the work that has been accomplished in the Ordnance Department is taken into cognizance by the study. Out of this basic analysis it has been sought to develop an actual appraisal of the economic possibilities of mechanization before undertaking any costly experimentation.

Wider Highways

Wider roads are everywhere in demand. Increased traffic on our public highways makes wider roads a prime essential, and public officials who fail to take this vital fact into the reckoning make a mistake.

According to a writer in the Memphis Commercial Appeal, "road widening has become a definite policy in several states in which the automobile registration is high;" one of these states has been adding strips of paving from three to six feet to some of its roads; another is placing along its roads lateral extensions of from twelve to eighteen feet, and these widening policies are particularly to be noted in metropolitan areas around some of the larger and more important cities of the country. Narrow roads do not take care of the traffic, and besides, they are more dangerous than roads of wider types.—*Industrial News Bureau.*

Federal Services Finance Corporation

At a recent meeting of the Board of Directors of the Federal Services Finance Corporation, the Board approved the arrangements made by the officers for offering an issue of Five Year, Six Per Cent Debentures in denominations of \$300 and \$500 to be ready for delivery about March 1, to be offered to the Military-Naval Services on such monthly payment plan as will enable them to make purchases out of their monthly savings. The proceeds from the sale of these debentures will be used in extending their business of making loans to officers of the Army, Navy, and Marine Corps and in financing the purchase of automobiles and other commodities bought on the deferred payment plan.

COAST ARTILLERY BOARD NOTES

Communications relating to the development or improvement in methods or material for the Coast Artillery will be welcome from any member of the Corps or of the Service at large. These communications, with models or drawings of devices proposed, may be sent direct to the Coast Artillery Board, Fort Monroe, Virginia, and will receive careful consideration. W. E. COLB, Colonel, Coast Artillery Corps, President, Coast Artillery Board.

New Projects Received and Initiated

Project No. 603, Auxiliary Firing Magneto for 12-inch B. C., M. 1917.—The Coast Artillery Board made a study of the advisability of installing an additional firing magneto below the working platform of the 12-inch Barbette Carriage, Model 1917 M1. The Board recommended that a firing magneto be installed on one of the carriages of either Battery Mills or Kingman, Fort Hancock, New Jersey, for test.

Project No. 604, Test of Pneumatic Tires (32x6) on Model 1925 Cadillac Searchlight Truck.—This test, being conducted by the 61st Coast Artillery (AA), is for the purpose of determining whether the Model 1925 Searchlight Truck (Cadillac) can transport the searchlight and searchlight crew of five men, with special reference to the durability of standard 32x6 pneumatic tires.

Project No. 605, Lights for Illuminating Sights, Scales, Azimuth Instruments, and Aiming Posts.—The Coast Artillery Board is making a study of this subject with a view of determining the most desirable source of power for illumination of sights, scales, and aiming posts.

Project No. 606, Track Tools for Railway Artillery.—The Coast Artillery Board is making a study of the subject of track tools and track maintenance equipment for railway artillery.

Project No. 607, Code Signals for Use In Aerial Observation of Fire.—The Coast Artillery Board made a study of a proposed revision of Air-Ground Liaison Code No. 1 and Air-Fire Control Code and recommended no change at present time, in so far as Coast Artillery is concerned.

Project No. 608, Duco Surfacing for Guns.—Four 155-mm. guns have been painted with "Duco." These guns are under observation by the Coast Artillery Board.

Project No. 609, Comparative Test of Self-Contained Range Finders (Stereoscopic and Coincidence) (For Use With 155-mm. Batteries).—This test is to be conducted at Fort Eustis during the coming spring and summer.

Project No. 610, Test of Experimental Extensible Telephone Handsets.—The extensible handset is the result of development by the Signal Corps carried on with a view to providing an instrument suitable for use either with or without the diaphragm gas mask. The construction of the handset is such that the separation between the transmitter and receiver centers, normally $6\frac{3}{4}$ inches collapsed, can be increased to $9\frac{3}{4}$ inches extended. This is accomplished by mounting on two lengths of brass tubing which slide in and out of the handle proper. The brass tubing is not a part of the electrical circuit. A lever switch, rather than conventional push button, controls transmitter battery. The handset is undergoing test.

Completed Project

Project No. 569, Test of Stephens Deflection Board

I—HISTORY OF THE PROJECT.

1. *a.* The following is quoted from the report on Coast Artillery Board Project No. 569, Stephens Deflection Board (Preliminary Report).

III—CONCLUSIONS.

5. The Coast Artillery Board is of the opinion:

a. That the Stephens Deflection Board appears superior to any other deflection board that has come to its attention.

b. That the Stephens Deflection Board, which has been constructed, has been perfected to such an extent as to warrant service test.

IV—RECOMMENDATIONS.

a. That the Stephens Deflection Board already constructed (degree model) be tested during drill and subcaliber and service firings in both Case II and Case III during any experimental firing, or any firing for the Coast Artillery School, which is to take place at Fort Monroe or Fort Eustis prior to December 1, 1927.

b. That the Stephens Deflection Board now under construction (mil model) upon its completion be tested during drill and service firing in both Case II and Case III by the 51st Coast Artillery; and that twenty-four (24) rounds of 155-mm. service ammunition be allotted for this test.

b. The following is quoted from letter from the Office, Chief of Coast Artillery, dated September 19, 1927, Subject: Project No. 569 (OCCA File 413.6811/F₂).

1. The conclusions and recommendations made in your Project No. 569 are approved.

2. It is desired that service tests with both types of this Deflection Board be conducted and the reports of same rendered as early as practicable so that steps may be taken toward having the Ordnance Department proceed with the manufacture of pilot models. In this connection attention is invited to correspondence transmitted to you this date per 5th Indorsement O. C. C. A. 665/AH-13. See also 1st Indorsement, C. C. C. A. 413.6811/F-1, September 19, 1927, copy inclosed.

II—DISCUSSION.

2. Description and operation of the Stephens Deflection Board appear in an appendix hereto.

3. *a.* The Stephens Deflection Board which was constructed at Fort Monroe and Fort Eustis, was tested at Fort Eustis on October 14, 1927, during a demonstration firing (service) of 155-mm. guns by Battery A, 51st Coast Artillery, for the Coast Artillery School.

b. For this test a gear train giving a ratio of 8 to 1 was substituted for the original gear train which gave a ratio of 9 to 1. Blue-print scales were pasted over the metal scales. The blue-print scale on the main disc was graduated in mils, the circumference being divided into eight hundred divisions, each representing one mil. The blue-print scales on the discs B and C (Fig. 1) were divided into sixty-four divisions, each representing one hundred mils. Thus, to pass through the entire sixty-four hundred mils, the disc B would make one revolution and the main disc would make eight revolutions.

c. The board functioned satisfactorily during the test and no defects were discovered.

d. The firing during the test was by Case III.

4. The Stephens Deflection Board was tested further during Coast Artillery School instruction firing (service) at Battery Anderson, 12-inch mortars, on October 28, 1927. The board functioned satisfactorily and no defects were discovered.

5. a. The Stephens Deflection Board was tested further during service firing at Battery DeRussey (12-inch guns) on November 4, 1927. Firing was by Case III.

b. The board functioned satisfactorily during the test and no defects were discovered.

c. Informal report submitted by the Range Officer is attached hereto.

6. a. The only test of the Stephens Deflection Board during firing by Case II was in October, 1927, during subcaliber practice by Battery A, 51st Coast Artillery.

b. The board functioned satisfactorily and no defects were discovered.

c. The angular-travel device functioned perfectly and is more satisfactory and expeditious than any other means of determining angular travel during time of flight that has come to the attention of the Coast Artillery Board.

7. The displacement corrector, incorporated as an integral part of the Stephens Deflection Board, has been subjected to laboratory test only. This device permits of obtaining corrected azimuth of a setforward point from a gun (or point) displaced from the directing gun (or point) as well as the azimuth of the setforward point from the directing gun (or point). The maximum difference between the azimuth of setforward point from displaced gun (or point) and the azimuth of setforward point from directing gun (or point) for which the device will function is two degrees. It is believed that the scope of the device is ample. The following table gives maximum displacements corresponding to various ranges for an azimuth difference of two degrees, target on normal to line from directing gun (or point) to displaced gun (or point) :

<i>Range</i>	<i>Displacement</i>
5,000	174
6,000	209
7,000	244
8,000	279
9,000	314
10,000	349
11,000	385
12,000	419
13,000	454
14,000	488
15,000	528

8. a. Observation of the Stephens Deflection Board during tests and continued study of this device indicate it as the most satisfactory and complete deflection board that has come to the attention of the Coast Artillery Corps.

b. Improvements over the model tested which should be incorporated in future models are as follows (Note: References in this paragraph are to

Figure 1 unless otherwise indicated).

- (1) Complete graduation of the main disc (A) (every .05 of a degree for the degree model and every mil for the mil model).
- (2) Substitution of pointers for the subscales (B).
- (3) A more accessible clamping screw on the slotted arc (C).
- (4) A more accessible clamping screw on the adjustment correction device (D).

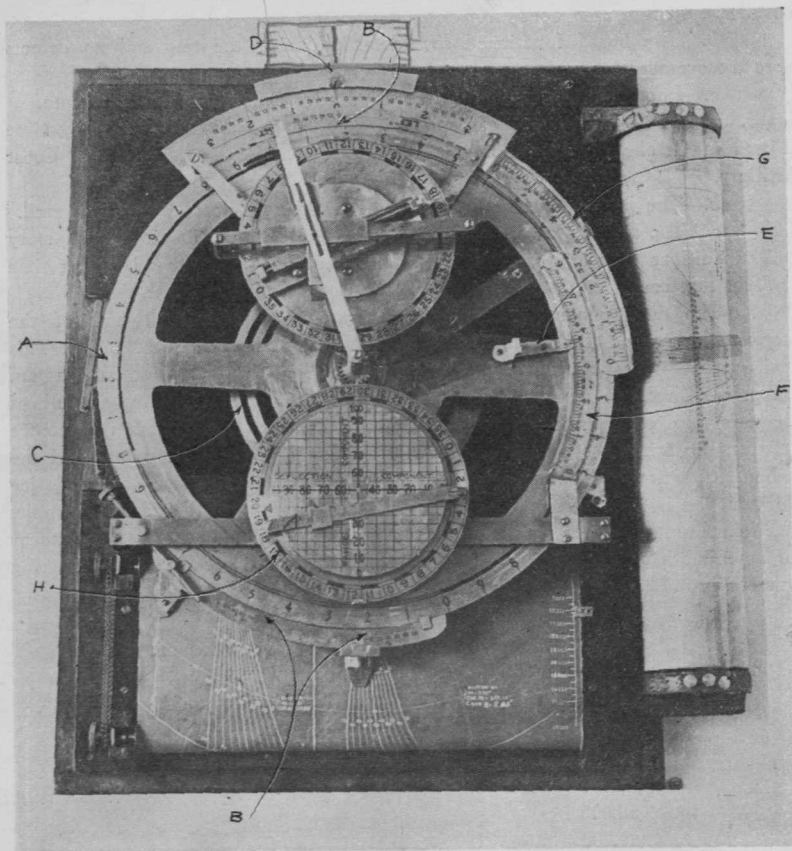

FIG. 1

(5) An automatic stop for the angular travel pointer (E) so as to facilitate the setting of this pointer at the center (3 on the scale illustrated) of the angular-travel device.

(6) Extension of the angular-travel scale to care for the maximum travel to be considered (5.5 degrees in 30 seconds). Figure 2 shows that a travel of 5.5 degrees in 30 seconds will occur with a target moving directly across the field of fire at a speed of 30 miles per hour at a range of 4500 yards.

(7) A slight change in the position of the deflection scale (G) so that when

the board is adjusted for Case III fire it is also adjusted for Case II fire.

(8) A wind scale in mils (graduated every 100 mils) interior to and concentric with circular scale (H) on the degree model.

(9) The graduation of each disc in mils on one side and in degrees on the other side, so that the board may be changed from the mil to the degree model, or vice versa, by the reversal of the discs and the substitution of the proper gears. (Note: It is believed that the graduation of discs can be accomplished at very small expense by photo-engraving or etching; and it appears desirable for all boards to be graduated in both mils and degrees).

(10) The provision of two gear trains, one having a ratio of 8 to 1 and the other a ratio of 9 to 1 for each board so that the board may be used as either a mil or degree model. (The 8 to 1 ratio gear train can be made up of standard Boston gears at a cost of about \$7.00, and the 9 to 1 ratio gear train at a cost of about \$9.00.) (Note: It is believed that each of the first few boards should be provided with both gear trains. Later when the device is entirely standardized it may be desirable to issue both gear trains with but a small percentage of the deflection boards, but any board, whether or not two gear trains be issued with it, should be susceptible of being changed from the degree to the mil model, or the converse, by the substitution of standard parts.)

(11) The substitution of a metal base for the wooden one used on the board made by the Coast Artillery Board.

(12) The provision of a case so designed as to prevent movement of the various parts of the board and to permit of its being transported in a truck.

(13) The two rollers which carry the cross-wind and drift and rotation correction curve charts to be mounted in a removable metal frame; this frame to be so fitted to the base of the deflection board as to permit of its being adjusted radially and tangentially. The object of having the metal frame removable is to facilitate the mounting of charts.

III—CONCLUSIONS.

9. The Coast Artillery Board is of the opinion that the Stephens Deflection Board with the improvements enumerated in paragraph 8 above, will be entirely satisfactory for use with Coast Artillery armament, mortars and guns, fixed and mobile, and that it is superior to any other deflection board as yet considered, and is suitable for adoption as standard.

IV—RECOMMENDATIONS.

10. The Coast Artillery Board recommends:

a. That the manufacture of four Stephens Deflection Boards, carrying the improvements listed in paragraph 8, at Frankford Arsenal, be expedited so as to be available by May, 1928.

b. That, as early as possible, Stephens Deflection Boards be issued as follows:

To the 52d Coast Artillery (Railway) (For use in tests to take place at Fort Story during the spring and summer of 1928)._____ 2

To Battery DeRussy (The first class, United States Military Academy, is scheduled to train at this battery in June, 1928, and it is

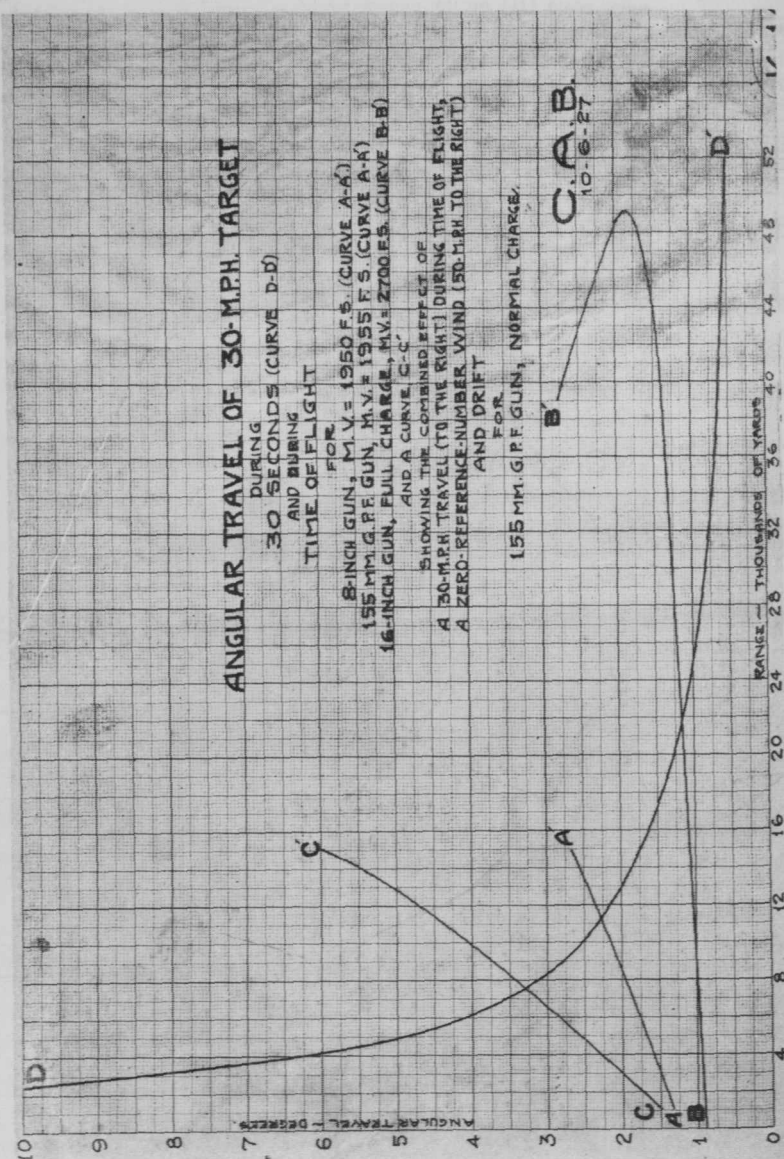
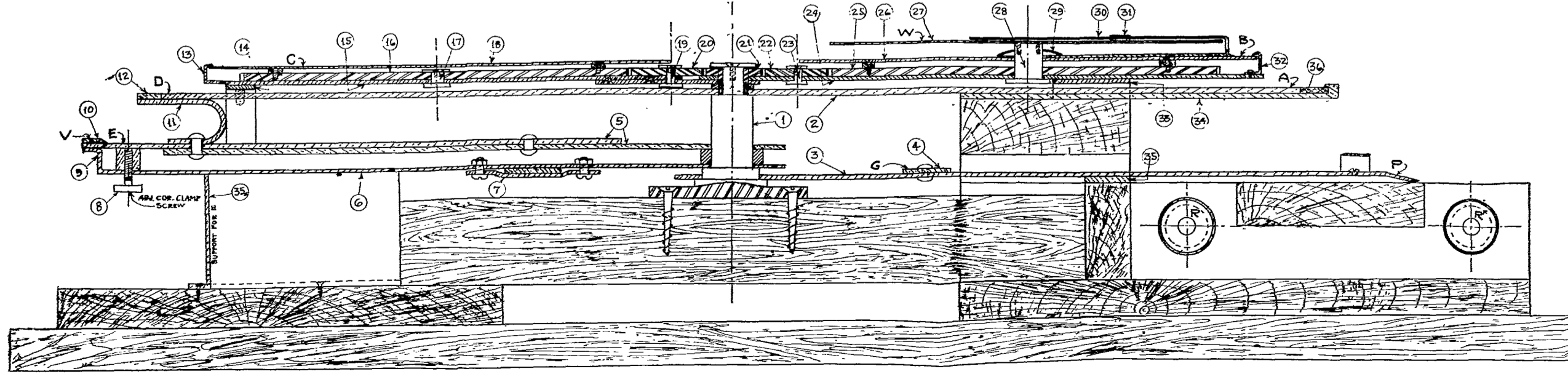
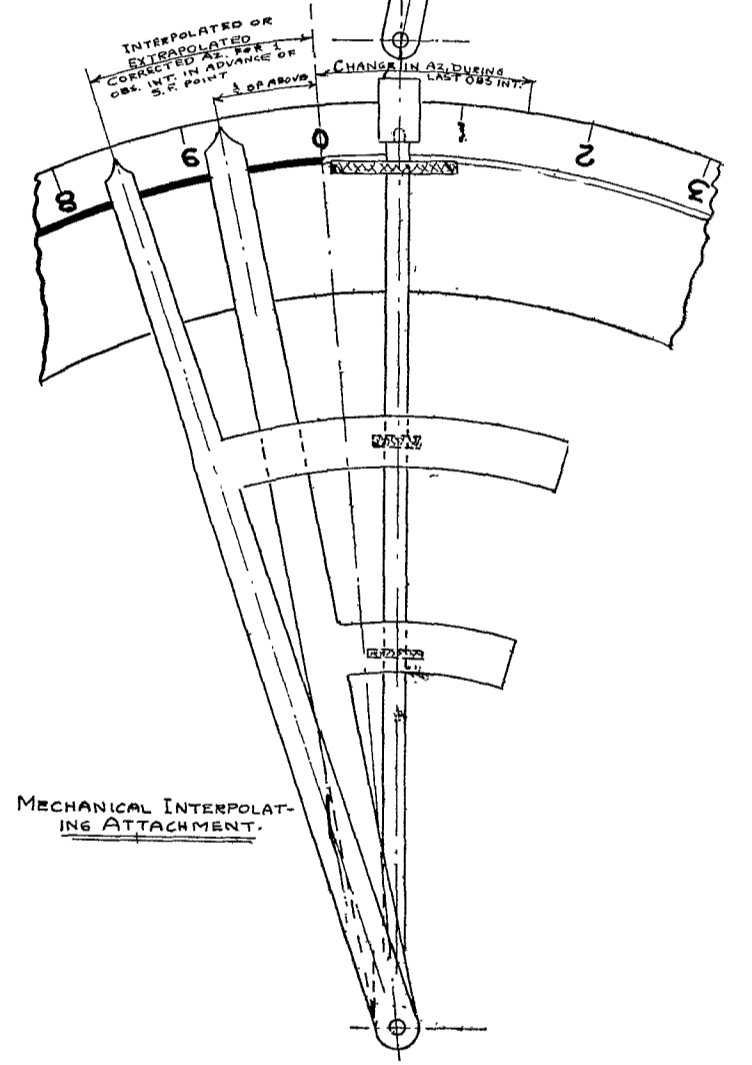
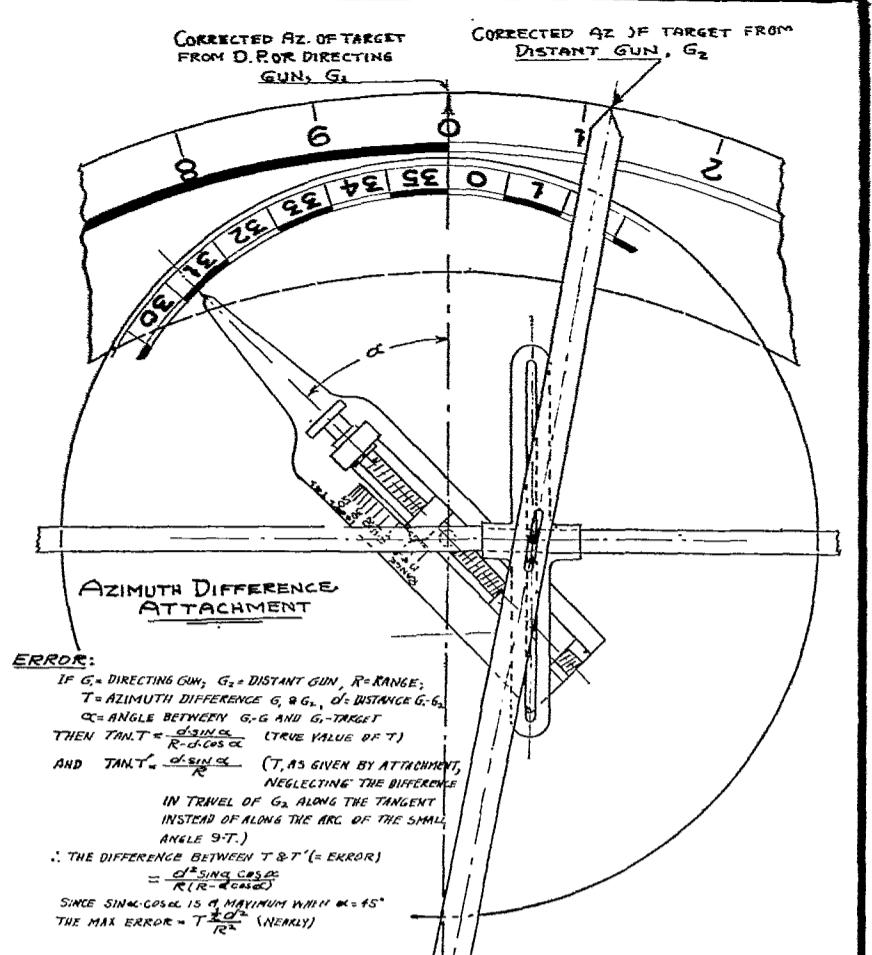
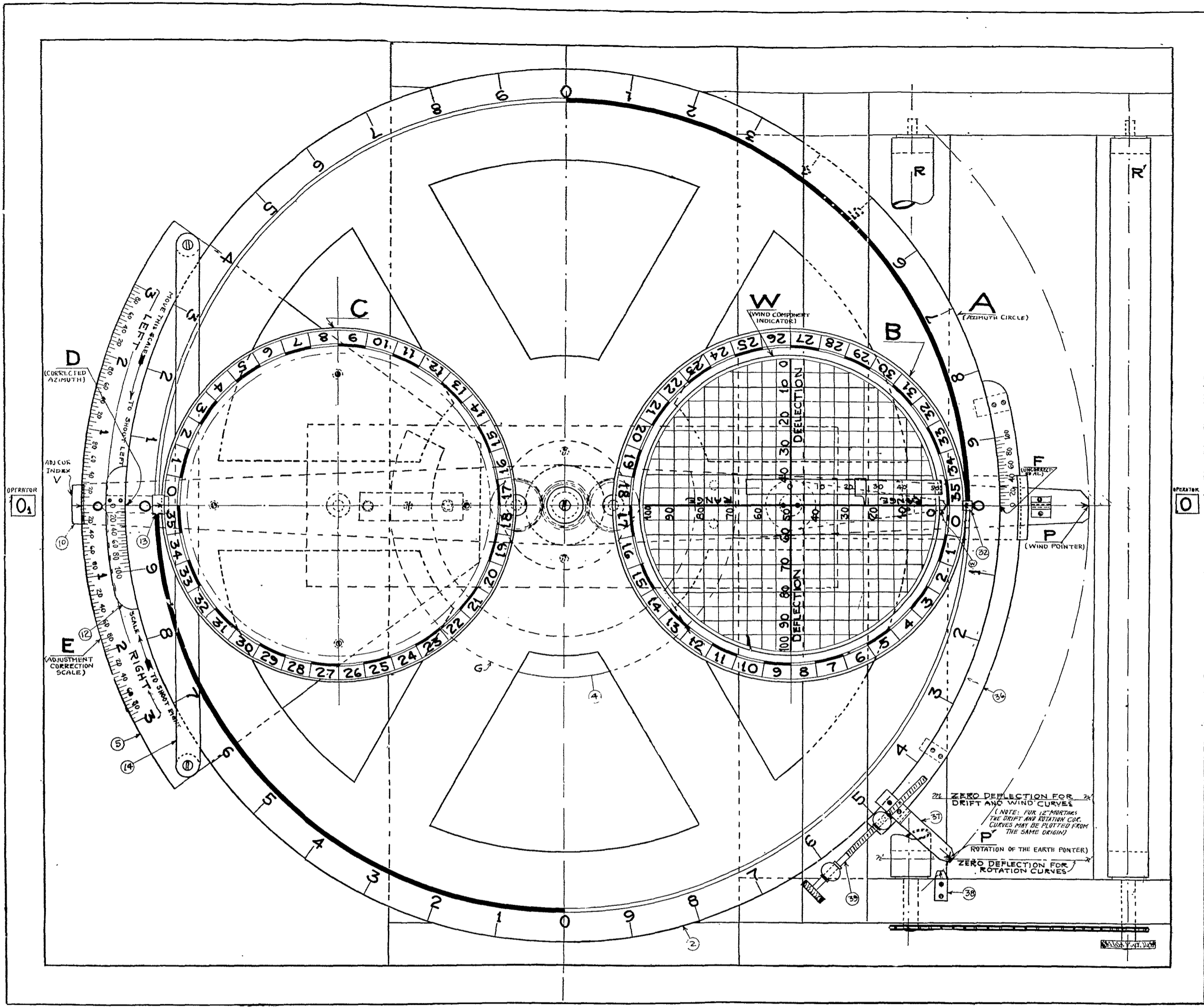
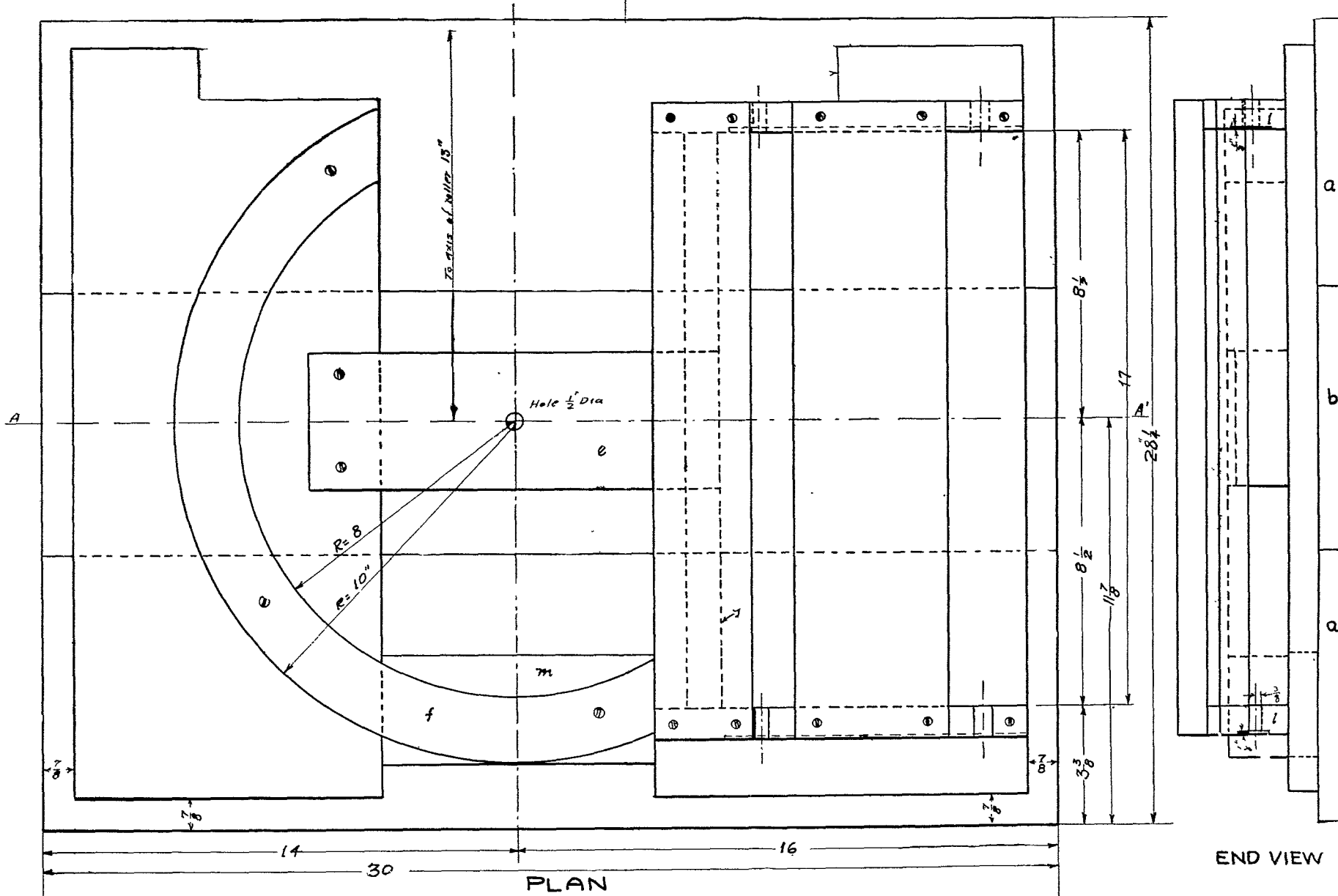

FIG. 2



COAST ARTILLERY BOARD FORT MONROE, VA		
DEFLECTION BOARD		
DESIGNED & DRAWN BY	DATE	FILE NO.
T.J. STEPHENS	APRIL 25, 1927	F - 4



MATERIAL			
PIECE	NO. REQUIRED	DIMENSIONS	REMARKS
a	2	$\frac{7}{8} \times 10 \times 30$	
b	1	$\frac{7}{8} \times 8 \frac{1}{2} \times 30$	
c	1	$\frac{7}{8} \times 11 \times 25 \frac{1}{2}$	
d	1	$\frac{7}{8} \times 9 \times 26 \frac{1}{2}$	
e	1	$1 \frac{1}{2} \times 4 \times 12$	Hard Wood
f	1	As shown	Semicircular Ring
g	2	$\frac{7}{8} \times 2 \times 6 \frac{1}{2}$	
h	1	$\frac{1}{2} \times \frac{7}{8} \times 4$	
i	2	$\frac{7}{8} \times \frac{7}{8} \times 3$	
j	1	$\frac{7}{8} \times 3 \times 18 \frac{3}{4}$	
k	1	$\frac{7}{8} \times 4 \frac{1}{2} \times 18 \frac{3}{4}$	
l	2	$\frac{7}{8} \times 2 \times 11$	Hard Wood
m	1	$\frac{7}{8} \times 3 \frac{1}{2} \times 8$	
n	2	As shown	Supports for roller "r"
p	1	As shown	Roller

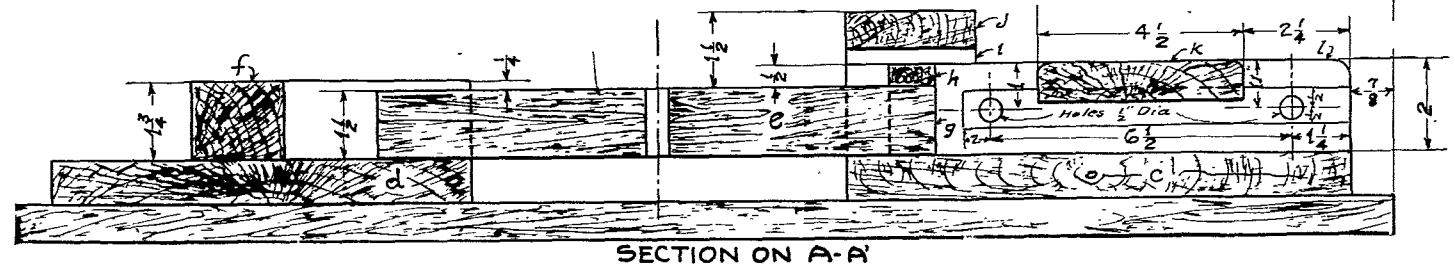
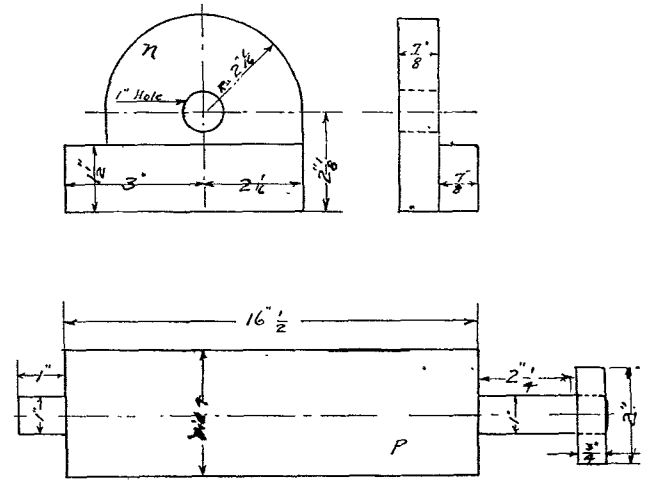

COAST ARTILLERY BOARD
FORT MONROE, VA

DEFLECTION BOARD
DETAIL OF WOOD-WORK

DESIGNED & DRAWN BY <i>JFS</i>	DATE MAY 3, 1927	FILE NO F-4a
-----------------------------------	---------------------	-----------------

FIG. 4

desirable that the latest equipment be available)..... 1

To the Coast Artillery School..... 1

c. That in order to facilitate the manufacture of these deflection boards:

(1) The Stephens Deflection Board made by the Coast Artillery Board be sent to Frankford Arsenal for such time as it may be of value there and then returned to the Coast Artillery Board.

(2) Technical Sergeant Thomas J. Stephens, Coast Artillery Corps, be ordered to Frankford Arsenal for temporary duty for a short period to assist in the interpretation of the design of the Stephens Deflection Board.

V—ACTION BY CHIEF OF COAST ARTILLERY.

413.6811/F-4

1st Ind.

War Department, O. C. C. A., January 31, 1928.—To Chief of Ordnance.

1. The recommendations of the Coast Artillery Board, contained in Paragraph 10 of Project No. 569 are concurred in.

* * * * *

APPENDIX A

Fort Monroe, Virginia.

November 19, 1927

Memorandum: To Major Putney.

Subject: Informal report on Stephens Deflection Board.

1. The Stephens Deflection Board was used by Battery B, 12th C. A., in firing Battery DeRussy on November 4, 1927.

2. The results obtained were very satisfactory. In my opinion it possesses the following advantages:

a. Short time it takes to teach men to operate it. In this firing the operators had only two drills on it before actually using it in target practice.

b. Simplicity of operation.

c. Does away with separate operation of wind component indicator.

d. Larger scales than Universal Deflection Board, thus making it easier to set the Stephens Board, and also making the settings more accurate.

3. In my opinion the Stephens Board is much more satisfactory than the Universal Deflection Board.

4. The improvement that could be made would be to simplify the method of resetting the board for use with guns after it has been used with mortars and vice versa.

(Signed) A. H. BENDER,
2nd Lieut., 12th C. A.

APPENDIX B

DEFLECTION BOARD

DESCRIPTION

Note: Unless otherwise stated all references are to Figure 3 (Drawing F-4).

Base (Fig. 4—Drawing F-4a). The board consists of a wood base (a), (b), (c), and (d). On (d) is mounted the semi-circular ring (f), forming a support for the arm (6) (Fig. 3). Mounted on (c) and (d) is the piece (e) to which is

attached the center-pin (1) (Fig. 3). (*g*) is a narrow strip forming a support for the arm (3) (Fig. 3). The two parallel strips (1) are the supports for the rollers (1) and (2) (Fig. 5), and mounted on (1) is the board (*k*) forming a table over which the deflection chart is carried. (*j*), which is supported at each end by the small blocks (*i*), forms a support for the arm (34) (Fig. 3).

Note: The blocks (*i*) are of sufficient thickness to allow arm (3) (Fig. 3) to move freely between (*g*) and (*j*).

Center-pin (1), about which rotate the main azimuth circle (2), the arms (3), (5), (6), and (15), and about which is fixed the arm (24), is screwed to the block (*e*) (Fig. 4).

Arm (3), one end of which is pivoted about (1) and the other end forming the pointer (P), has attached rigidly the arc (4).

Arm (6), which carries the index (*v*), opposite which the adjustment correction is set, is caused to rotate with arm (3) by means of the arc (4) which is clamped to (6) by clamp (7).

Arm (5), on the outer end of which is rigidly fixed the segmental plate on which is carried the adjustment correction scale, is caused to move with arm (6) or may be moved independently of (6) by means of the clamp screw (8). Mounted on the plate is the brass strip (11) to which is attached the subscale (12), or (D), opposite which the corrected azimuth is read. This plate also carries the frame (14) which, in turn, supports arm (15).

Main Azimuth Circle, disc (2), is supported at the center by, and rotates about, the pin (1). This disc is marked, graduated (40 graduations, equally spaced), and numbered as shown in Figure 3. Rigidly attached to (2) and rotating with it is the gear (21), (21) being provided with a hub about which the arm (15) rotates and one end of arm (24) is supported.

Arm (15), which rotates about the hub of gear (21), is supported at its outer end by the frame (14) and has attached to it the studs (19) and (17) and the index (13).

Arm (24), supported at one end about the hub of (21) and at the other end by the brass strip (33)—(33) being supported at each end by wood or metal blocks resting on the board (*j*) (Fig. 4) of sufficient height to allow the disc (2) to rotate between (*j*) (Fig. 4) and (33)—has attached to it the studs (23) and (28) and the index (32).

Gears. Supported by and rotating about (19) is the gear (20), which meshes with (21) and (16) which is supported by stud (17). The dimensions of gears (21), (20), and (16) are such as to give to (16) one complete revolution (360°) while (21) makes nine complete revolutions (3240°).

The center of gear (16), being attached to arm (15) which in turn—through the frame (14), arms (5) and (6), and arc (4)—is attached to arm (3), will move through the same angle and in the same direction as (3). As the center of (16)—and (20)—is caused to move through any angle by arm (3) when (P) is being set to the proper correction curve, (20), meshing with (21) and (16), will cause (16) to turn about its center through one-ninth of the angular travel of (P) (which is one-ninth the angular travel of the center of (16) about pivot (1)).

Gears (22) and (25), mounted about studs (23) and (28), are of the same dimensions as (16) and (20) and the operation is the same except that the centers

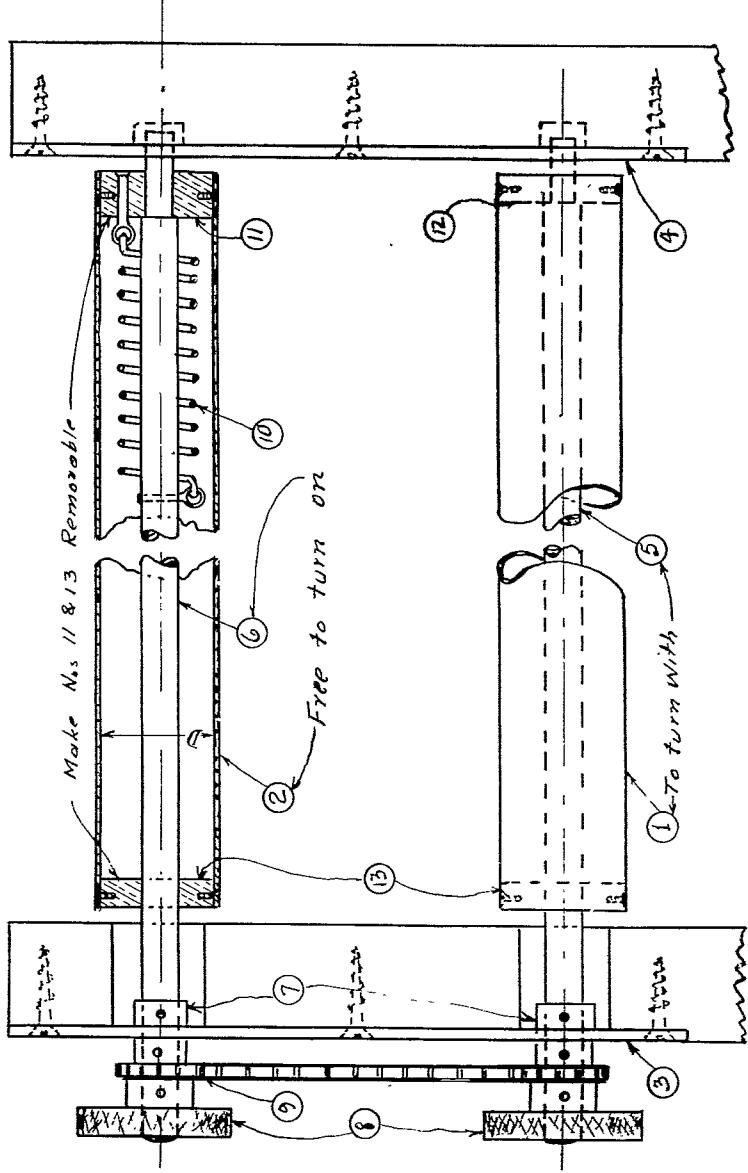
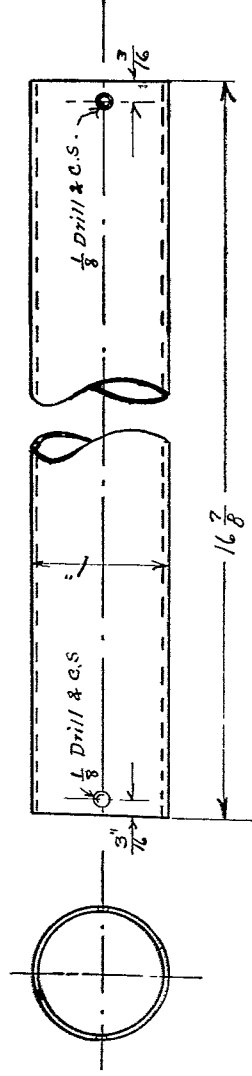
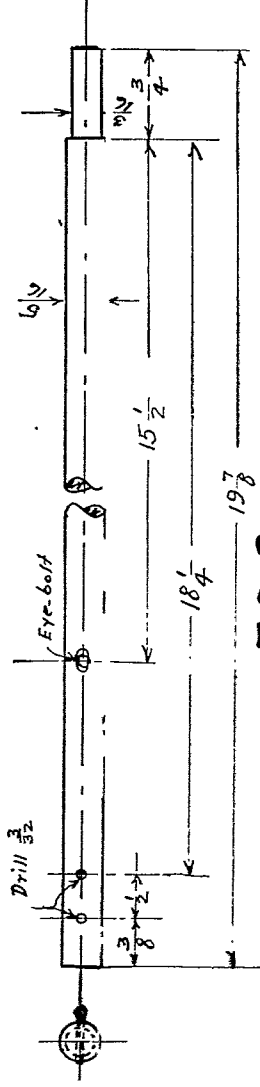

CHART ROLLERS



1 & 2



5 & 6

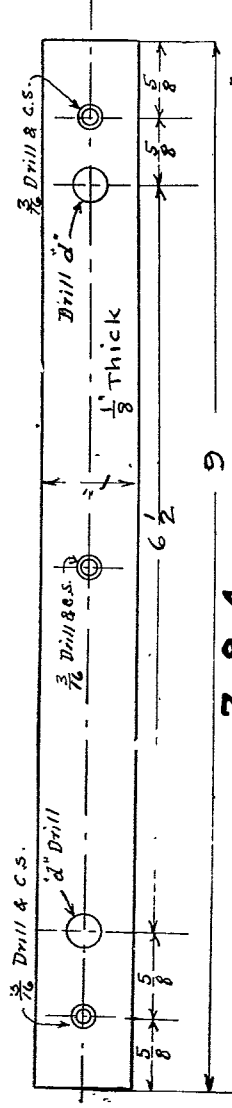

3 & 4

For 3 - $D = \frac{5}{8}$ "
 $A - d = \frac{5}{16}$ "

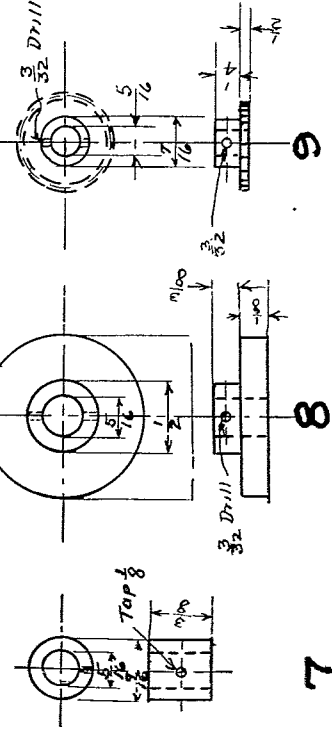

11, 12 & 13

$D =$ Inside Dia of Roller
 $d' = \frac{3}{16}$ " for 11 & 12
 $d = \frac{5}{16}$ " for 13

10

Helical Spring 15 Long

of (22) and (25) are fixed, relative to the base, instead of rotating with arm (3) as do (16) and (20)

Azimuth Numbering Disc. Attached to gears (16) and (25) are the discs (18) and (26), (or C and B), graduated and numbered as shown. On these discs are read (or set) the tens and hundreds of degrees of azimuth. The alternate closed and open lines just over the numbers are for minimizing the liability of reading the wrong figure. On the main azimuth circle (2) are corresponding open and closed lines so that when the reading or setting on the main azimuth circle falls on that part of the scale, including a closed line, then the reading or setting on disc (C) or (B) *must* be the figure (nearest the index) under a closed line. Similarly, when the reading or setting on the main azimuth circle is opposite an open line, then the reading or setting on (C) or (B) must be that figure under the open line.

Wind Component Indicator. Disc (27), (or W), graduated and numbered and lettered as shown, is mounted on stud (28), just above the numbering disc. Pivoted about (28) is the Wind Velocity Arm (30), on which slides the Wind Reference Number Indicator or pointer (31); forming a part of this arm is the pointer (w) by means of which the arm is set, on disc (26) to the azimuth of the wind. A small spring (29) holds the pointer in place and causes it to rotate with (26) or allows the pointer to be moved for making the azimuth of the wind setting.

Sub-scales (D) and (F). (D) is graduated and numbered as shown and is attached, through (11), to plate (5). (F) is graduated and numbered, as shown, on arc (36). This arc carries the pointer (P') and is moved by means of the tangent screw (39)—the fixed part of this screw is attached to (33).

Arm (34) is fixed to (j) (Fig. 4), and forms a support and guide for the arc (36).

Indices (13) and (32), attached to (15) and (24), respectively, are for indicating numbers to be set or read on (B) and (C). Index (38), mounted on (1) (Fig. 4), is for setting the deflection chart to proper range or elevation.

Chart Rollers. (Fig. 5). The rollers are mounted on the two wood blocks (1) (Fig. 4), by means of the brass strips (3) and (4) and rods (5) and (6). These rods are held in place by the collars (7) and are connected so as to rotate together by means of the sprockets and sprocket chain (9). Roller (1) is fixed to and rotates with rod (5), (2) being connected to (6) by means of the helical spring (10). One end of the spring is attached to the roller and the other end to the rod, the roller being otherwise free to rotate about the rod. Each rod is provided with a knob (8) for making the chart settings.

Azimuth Difference Attachment. (Fig. 6) (See also Figure 3 for diagrammatic sketch of method of mounting and operation). This attachment consists essentially of the frame (1), base (2), slide (3), and arm (4). The base—which is mounted on stud (17) (Fig. 3) and may be rotated about (17) for setting the "directing point—distant gun" azimuth, after which it is fixed to, and rotates with, disc (C) (Fig. 3)—on which is mounted a screw, forms a guide for two blocks through which the screw passes. One block has attached to it a pin which slides in the slot in the bottom piece of (3), the other block carries a pointer which passes over a scale on which is graduated the range for a particular gun displacement.

That part of the screw which carries the range pointer block has two times the pitch of the part which carries the pin, thus increasing the scale and permitting of more accurate setting of the range.

The frame (1) is attached to (15) (Fig. 3), and carries on bar (a) the part (3). The upper side of (3) has attached a pin which engages in the slot of arm (4). Arm (4) is pivoted at one end about the center of the main azimuth circle (disc 2), (Fig. 3), and the other end is provided with a subscale which moves

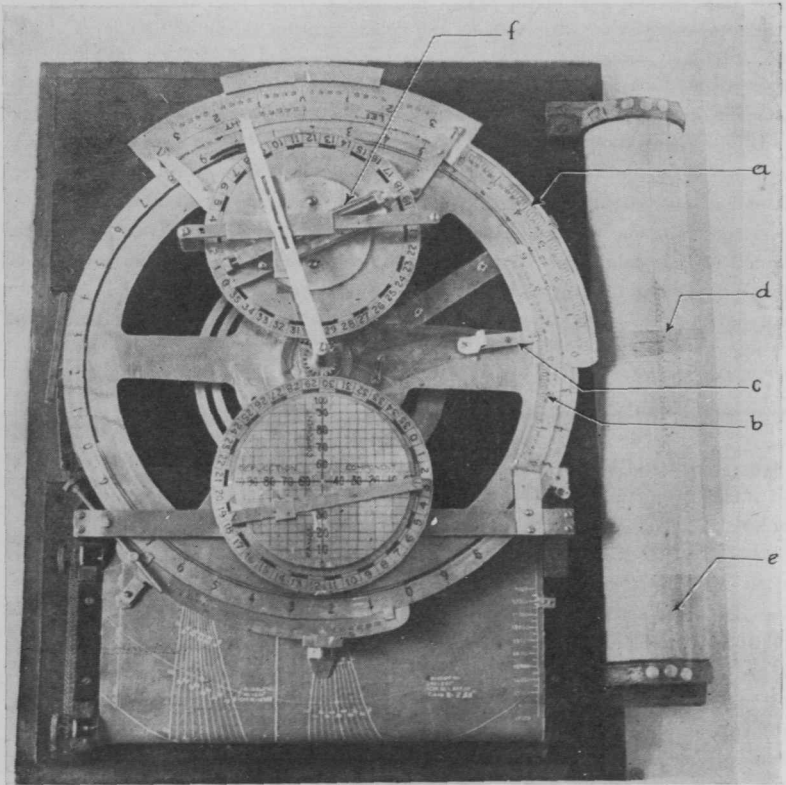

FIG. 7

over the main azimuth circle on which is read the corrected azimuth for the distant gun.

Device for Case II Firing. For Case II firing there are provided: *Deflection scale* (See (a), Fig. 7). Interchangeable scales may be provided to care for the different sight scales in use. Deflection scale is attached to and rotates with frame (14).

Angular travel scale (See (b), Fig. 7). This scale is fixed to (33).

Angular travel pointer. (See (c), Fig. 7). This pointer rotates about hub of main disc of board. It is designed so that it can be moved without moving the

main disc, but so that it moves with the main disc when the latter is rotated. The angular-travel pointer and the angular-travel scale enable the determination of the angular travel of the target during the observing interval.

Angular-travel arm (See (d), Fig. 7). This arm is pivoted at center of board and attached to no moving part thereof; it carries with it an index which is offset so as to be opposite the deflection scale. This arm moves over a cylinder (see (e) photograph below) upon which is mounted an angular-travel chart. The proper time of flight (or range) being set at the upper element of the cylinder and the angular travel arm being moved so that its axis is at the intersection of the upper element of the cylinder with the curve bearing the reference number obtained from angular travel pointer and angular travel scale; the index will have been moved along the deflection scale by the proper amount necessary to correct for the angular travel of the target during the time of flight. Deflection adjustment corrections in Case II are applied exactly as are azimuth adjustment corrections in Case III.

Displacement corrector. This device is illustrated by (f), Figure 7.

(Note. In the mil model under construction the main disc (No. 2) will be graduated throughout with a least reading of one mil. Pointers will be substituted for the subscales (vernier) F and D. Also, in any future board of the degree model the main disc will be graduated throughout with a least reading of .05 of a degree.

ADJUSTMENT

CASE II.

1. Set the chart (for the gun, projectile, and M. V. being fired) to the range (or elevation) indicated on the arc at about mid range.
2. Set arm (T') to the curve 3 on the roller.
3. Set adjustment correction scale to 0.00.
4. Loosen clamp (7).
5. Move scale (SS) so that the value read on the arc (Case II) is opposite the pointer (S).
6. Set pointer (P) to the wind curve indicated by the small concentric circles on the above arc.
7. Tighten clamp (7).

CASE III.

1. Same as for Case II.
2. Set pointer (P') to the rotational correction indicated by small concentric circles on the arc at about mid-range.
3. Set the uncorrected azimuth to the value (0.00) shown on the arc.
4. Loosen clamp (7).
5. Set adjustment correction scale to 0.00.
6. Bring vernier (D) (without moving the main azimuth circle) to the corrected azimuth shown on the mid-range arc.
7. Set pointer (P) to the wind curve indicated by the small concentric circles on the arc.
8. Tighten clamp (7).

EXAMPLE:

Given 10-inch gun, 617-lb. projectile, and M. V. 2250 f. s.

CASE II.

1. Bring the chart for 10-inch gun into position and set it to range of 12,000 yards (the range indicated on the arc).
2. Make adjustments 2, 3, and 4.
5. Set scale (SS) to 2.65° (the value for Case II as shown on the arc).
6. Set pointer (P) to 50 (the wind curve marked by small circles).
7. Tighten clamp (7).

CASE III.

1. Same as Case II.
2. Set pointer (P') to curve marked 0-360 (indicated by the small concentric circles).
3. Set the uncorrected azimuth 0.00 (the value shown on arc).
4. Make adjustments 4 and 5.
6. Bring vernier (D) to 359.58 (the corrected azimuth as shown on the arc).
7. Set pointer (P) to wind curve 50 (indicated by small circles).
8. Tighten clamp (7).

NOTES. 1. Separate adjustment must be made for each caliber gun, weight of projectile, and muzzle velocity, except for mortars where one adjustment holds for all zones but requiring separate adjustment for subcaliber and service projectiles.

2. Uncorrected azimuths for mortars must be set opposite vernier (M): for guns, opposite vernier (G).

OPERATION

Two operators are required.

Operator A operates the wind component indicator, sets the uncorrected azimuth and keeps pointers (P) and (P') set to the proper curves, and the chart set to proper range or elevation.

Operator B

Case II—Operates the travel device, sets any adjustment correction and reads the sight setting.

Case III—Sets any adjustment correction and reads the corrected azimuth.

EXAMPLE:

Given 10-inch gun; 617-lb. projectile; M. V. 2250 f. s.; azimuth of wind 200° ; velocity of wind, 30 mph.

<i>Time</i>	<i>Range</i>	<i>Uncorrected azimuth</i>	<i>Time of flight</i>
0	10,000	121.25	16.5
1	10,100	121.95	16.7
2	10,200	122.70	16.9

CASE II

<i>Time</i>	<i>Operator A</i>	<i>Operator B</i>
0	Set wind pointer to azimuth of wind, 200°. Set pointer to wind velocity, 30 mph. Set uncorrected azimuth, 121.25°. Set range, 10,000. Set (P) wind reference No. 80, as read from wind component indicator.	Set arm (T) to 3 on scale (TS).
1	Set range 10,100. Set azimuth, 121.95°. Set (P) to wind ref. No. 80.	Set time of flight, 16.7. Read opposite (T), 3.70 Set (T') to the reading opposite (T) 3.70°. Read sight setting opposite (S) 3.34°. Set arm (T) to 3.
2	Set range 10,200. Set azimuth 122.70°. Set (P) to wind ref. No. 79.	Set roller to time of flight, 16.9. Read opposite (T) 3.75. Set (T') to 3.75. Adjustment correction: left .30° Read sight setting 3.06° Set (T) to 3.

For each successive time interval, repeat the operations in time 2.

CASE III

<i>Time</i>	<i>Operator A</i>	<i>Operator B</i>
0	Sets wind component indicator to azimuth of wind, 200°. Set pointer to wind velocity 30 mph. Set range to 10,000 yards. Set (P') to azimuth of target 0-360°. Set uncorrected azimuth, 121.25°. Set (P) to wind reference No. 80.	Read corrected azimuth of target 121.14°.
1	Set chart to range 10,100. Set (P') to azimuth of target 0-360°. Set azimuth of target, 121.95°. Set (P) to wind reference No. 80.	Read corrected azimuth of target. 121.83°
2	Set chart to range, 10,200. Set (P') to azimuth of target 0-360°. Set azimuth of target, 122.70°. Set (P) to wind reference No. 79.	Set adjustment correction, left 0.30° Read corrected azimuth, 122.26°

Repeat for each successive time interval.

DISPLACEMENT CORRECTOR

Construction of range scale for a given gun displacement.

Given: G_1 the directing gun; G_2 distant gun; A azimuth of G_2 from G_1 ; L , length of the line G_1-G_2 ; a , the angle subtended by G_1-G_2 ; R , range.

Compute the angle a for every 5000 yards range and for an azimuth of $A+90^\circ$;

$$\tan a = \frac{L}{R}$$

Set the displacement azimuth pointer to A and clamp (so that displacement corrector rotates with disc (C)).

Set disc (C) to the azimuth $A+90^\circ$.

With the main azimuth circle set to $A+90^\circ$, bring (by means of the screw) the displacement correction vernier to $A+90^\circ+a$, for each computed value of a , and mark on the range scale opposite the pointer the ranges for which a was computed.

Having the ranges for every 5000 yards marked on the scale, the range at 1000-yard intervals may be interpolated.

OPERATION:

Keep pointer set to range of target. Opposite the displacement corrector vernier read the corrected azimuth of G_2 .

EXAMPLE:

Given $L=150$ yards.

$A=190^\circ$.

R (Ranges) =	5,000	10,000	15,000	20,000	30,000
a (Tan a) = $\frac{L}{R}$	1.72°	0.86°	0.57°	0.43°	0.29°
$A+90^\circ+a=$	281.72	280.86	280.57	280.43	280.29

Set displacement correction vernier to the above azimuths and mark opposite the pointer the corresponding ranges.

When the range pointer is set to the proper range and the azimuth from G_1 set, the corrected azimuth from G_2 will be indicated opposite the displacement correction vernier.

In the following table is a comparison of the azimuth of G_1 and G_2 for various azimuths of G_1 and range 5000 yards.

<i>Az. from G_1</i>	<i>Az. from G_2</i>
190	190.00
220	220.88
280	281.72
310	311.47
10	10.00
40	39.12
100	98.28
130	128.53
160	159.17
250	251.51

BOOK REVIEWS

Reminiscences of Adventure and Service. By Major General A. W. Greely, U. S. A., Retired. Charles Scribner's Sons. 1928. 6"x 8½". 356 pp. Ill. \$3.50.

When a man reaches the venerable age of eighty-four years and can look back upon sixty-five years of continuous public service, conspicuous for sincere endeavor, honesty of purpose, and successful achievement, he has the material for an autobiography that will be an incentive and a guide for those who are coming after.

Adolphus W. Greely, the author of *Reminiscences of Adventure and Service*, was born in 1844 at Newburyport, Massachusetts, and traces his descent from Massachusetts pioneers who "for nine generations labored with their hands in New England." From both his father and his mother Greely inherited a taste for reading and for good literature, which undoubtedly accounts for his discriminating use of words and for the clear, direct, and pleasant narrative style in which the autobiography is written; for his schooling ended at the age of seventeen, when he finished the four years in the local high school.

It is hard to imagine how a man could have crowded more of action and varied experience into one life—even a long one. In 1861, before he was eighteen, Greely enlisted as a private in a Massachusetts company and saw almost continuous service during the Civil War—Ball's Bluff, McClellan's Peninsular campaign, the Chickahominy campaign, Antietam, Fredericksburg. He was wounded during the retreat from Richmond and again at Antietam, and his descriptions of life in camp and on the battle field are vivid and valuable word-pictures of a tremendous conflict.

At the close of the Civil War, Greely decided upon an army career and, as a lieutenant in the 36th Infantry, he saw service at frontier posts in Wyoming and Utah. The chapters describing the Western plains in 1867 and Salt Lake in the 70's make intensely interesting reading.

In 1881, Greely, then a lieutenant in the Signal Corps, was put in command of the International Polar Station at Lady Franklin Bay, and the expedition is usually known as the Greely expedition. The tragic story of the three years of Arctic exploration and scientific observation is told in Greely's book, published forty years ago, called *Three Years of Arctic Service*. Of the eighteen army men who composed the Greely party, ten died of starvation, one soldier was shot for theft, and seven were rescued by the relief expedition commanded by Capt. W. S. Schley, two years overdue.

General Greely was made chief of the Signal Corps in 1887, and under his supervision the Weather Bureau was reorganized, and the Corps rendered especially valuable service in the handling of cable communication during the Spanish-American War. The inside history of the Santiago campaign is told for the first time in great detail. General Greely superintended the installation of the telegraph and cable lines in Alaska; and in 1906, when the great fire occurred in San Francisco, as Major General of the Line, he was in command of the relief work in the stricken city for ten months.

During General Greely's long years of public service in the United States and on his frequent journeys abroad he came into more or less intimate contact

with all of the outstanding men and women of the day. The latter part of the autobiography is given over to intimate glimpses of many of these people of importance—presidents and their families from Buchanan to Coolidge, explorers, actors, artists, foreign diplomats, and rulers. “To mention all of them—these countless men and women of eminent and lovable qualities—would require many pages of this volume. Especially fortunate am I now, since the inspiration of joyous action has passed, to be able to live over in memory these friendly relations, almost entirely unmarred by disagreements. The kindness and charity of these able men and talented women gave grace to my past career, and now add happiness to my peaceful declining years.”—E. L. B.

The Army and Sea Power. By Major R. B. Pargiter and Major H. G. Eady. Ernest Benn, Limited, London. 1927. 5½" x 8½". 220 pp. Maps. 12s 6d.

This is a book which should be read by all army and navy officers, if for no other reason than that it gives in outline Britain's long experience in overseas expeditions. It makes no attempt at detailed studies of these campaigns or close analysis of the causes of their success or failure. Many fat volumes would be necessary for that. But the inter-relation of land and sea forces is clearly shown. It matters not whether it be an attacking force thrown overseas, or a lonely outpost defending itself against such a force—the fleet and army have joint work to do. And no reader of this book can miss the point that intelligent cooperation between them spells success, and the lack of it failure.

On sea power the authors write: “First, the nation must be a seafaring one, with its roots deep in the sea, and containing a large population who ‘go down to the sea in ships.’ . . . Secondly, in order to protect this trade, it must have a powerful and efficient fighting fleet. And thirdly, in order to give this fleet full mobility, . . . it must possess a suitable network of maritime bases at strategic points on the principal sea routes. . . . These are the three essential foundations of sea power, and if any one of them is lacking the edifice is not secure. The first is the contribution of the nation as a whole, the second that of the Navy, and the third, to a great extent, that of the Army.”

Then follows 200 pages in which the long story of the building up of British sea power is told. From 1500 to 1920 one expedition after another is recorded. It is amazing how many of them there were and to what odd and out-of-the-way corners of the world British troops have at one time or another penetrated. Still more striking is the number of badly planned, muddled, mishandled expeditions, of generals and admirals who quarrelled or otherwise made fools of themselves, and the ghastly toll in life which their stupidity entailed. For example: “The price had been out of all proportion to the result. The total loss in these West Indian campaigns (1793-1802) are estimated by Fortescue at ‘little fewer than 100,000 men, about half of them dead, the remainder permanently unfitted for service; the losses in dead exceeding the total losses of Wellington's Army from death, desertion, discharges and all causes, from the beginning to the end of the Peninsular War.’”

The book is well written and has some apt passages which our more rabid pacifists would do well to read: “As usual, England had been lulled to sleep by her political prophets, and was quite unprepared. Speaking in February, 1792, the younger Pitt, then Prime Minister, had said: ‘Unquestionably there never was a time in the history of this country when, from the situation of Europe.

we might more reasonably expect fifteen years of peace than at the present moment.' Actually, England was on the threshold of the most desperate struggle she had ever waged, a struggle which was to last, with only a few brief interludes of peace, until 1815." And in speaking of Lord Aberdeen, the British Premier at the time of the Crimean War, the authors say: "Truly did Kinglake write of him that 'he drew down war by suffering himself to have an undue horror of it.'"—S. M.

A Subaltern on the Somme. By Mark VII. E. P. Dutton and Company. 1928. 4¾" x 7¼". 229 pp. \$2.00.

Probably the World War has been the inspiration or the excuse for more outbreaks into print than any other single happening in the history of mankind. Truth or fiction, tragic or humorous, with literary or historic merit and without merit of any kind, books on the Great War have come and gone since 1914 in a constant procession. But now and then a book appears in this martial line that stands out with a distinct individuality; and *A Subaltern on the Somme* takes its place among these few.

A Subaltern on the Somme is written in diary form; but that is true of several widely-read books of personal experience on the Front that have previously appeared. There are many pages in *A Subaltern on the Somme* that tell of suffering to the limit of human endurance and of horror almost beyond belief; but such recitals are found in other first-hand accounts of life in the front-line trenches, where the living existed literally among the dead. The thing that sets this book apart from its fellows is the same quality that makes "The Big Parade" the greatest of war pictures—its spirituality; the attempt to reconcile the wholesale sacrifice of human life with the existence of a compassionate, universal law.

The author of *A Subaltern on the Somme* hides his identity under the pen-name of Mark VII, but he cannot hide his personality or his character. An educated English gentleman, he goes to the Front because the traditions of his caste demand it—it is the thing to do. But his idealism and his sensitive imagination seriously interfere with his getting hold of "the business end of the war."

Well enough I know that I shall never be the real soldier. He lives on pinnacles of indifference I have long decided I shall never reach; but at least one can die decently; at least I've resolution enough for that. Whether I have sufficient to look a man in the face and then blow out his brains with this revolver remains to be seen. . . . I haven't solved the Front. By that I mean imagination and actuality are not yet at one; and in handling any problem it seems to me you haven't the whip-hand of it until imagination and actuality are at one. Whenever I see the Front in the light of what made me join the army—whenever I think of the whole business as a task, then I welcome the Front and feel I can eat fire easily. Imaginatively I have it all right. But when I shrink to little actuality and think of watery trenches, sinister-looking crump-holes, barbed wire, machine-guns, bombs, and most of all, big guns and intensive shelling, then the whole place becomes a land of foreboding, even of horror, where blind Death keeps groping hideously. It becomes a place I would give anything to keep out of, as you would a house that threatened every minute to fall about your ears.

But these two images have to become one before you have solved the Front, and in my case I know that can only come about when actuality

has been wholly swallowed up by imagination. . . . Somehow I must get hold of a sense of true proportion and be able to keep it, and not let the first law of Nature, or any other individual consideration, play old tricks by setting up a dualism which destroys the dream in the misery of the business.

When I can do that I shall have solved the Front. It is like focussing the lenses of these field-glasses. There is a spot where you get perfect sight with both eyes; but it takes finding. . . .

Mark VII is a keen judge of men, and the pen pictures of officers and soldiers who cross his path are exceedingly vivid character sketches. Here is a very brief one that is too clever to be omitted.

Taylor, a captain who had one of the companies before the 1st of July, has returned to the battalion and taken over the adjutancy. He is a tall, lean, well-educated man, with a superficial ease and grace of manner that must be welcome to hostesses. A perfect diplomat, his stimulated vivacity in the presence of his superiors leaves him at other times with that look of weariness so typical of the tactician. I see him as a slave of the desire to please, and even while I despise him for it, feel an innate sympathy with him.

Accustomed to association with gentlemen of his own class, some of the emergency officers with whom Mark VII is thrown into close contact prove unwelcome companions. "Just now the hut contains two of the new officers posted to D. company. They are loud, swaggering, insensitive hulks, very proud of their belts after their apprenticeship as commercial travellers. Preferring the company of gentlefolk, I should be happier living with the men. 'An officer and a gentleman.' It is a matter of character. Without character there can be neither. Men of mean spirit, bearable at other times, become unbearable in the trenches; for in the trenches, want of spirit stinks."

The pitiful human drama dragged along until a bursting shell brought it to an end for "Mark VII", who was invalided home, still speculating, to write "the simple truth" . . . for those among us who will soon be men and women, to whom the war is not even a memory—nothing but a great adventure just missed through an unlucky accident of birth. They'd like to know, they say; and their children's children rise in vision plying our ears with questions easy to be answered now, but unanswerable when the moss is thick on our graves."—E. L. B.

Principles of Radio Communication. By John H. Morecroft, assisted by A. Pinto and W. A. Curry. Second Edition. John Wiley & Sons, New York. 1927. 6"x 9". 1001 pp. Ill. \$7.50.

Professor Morecroft's book is probably the one book that should find a place on the bookshelf of every amateur and radio student. At the time of publication of the first edition radio was in its infancy and this edition covered its field, but since that time rapid strides have been made in radio science and for the past few years there has been a need for a more up-to-date book on this subject. Although, in a subject that advances at the rate at which radio does, it would be impossible to keep such a book up to date, this book contains a discussion of the latest American development—the shielded grid tube. (Europeans have used this principle for some time.) A great deal of information of interest to the broadcast receiver radio fan has been added.

the presentation of the electron theory has been improved upon but due to the disagreement of physicists on the nomenclature of positive and negative charges this discussion is not as clear as it might be. For the exploded theory of the ether the author has given us a substitute.

Most of the phenomena such as radio waves, propagation of light, etc., which apparently require for their explanation an ether with impossible properties, can be reasonably well pictured if we consider the ether as the superimposed electric fields of all the electric charges in the universe. . . . Of course it is to be remembered that building up a reasonable picture of a phenomena is by no means the same as explaining it.

The subject of shielding, which has become of prime importance in broadcasting receivers, has been added.

The chapter on spark telegraphy has been cut down and new material about receiving circuits, detectors, power in sound waves, audibility and selectivity, and characteristics of crystal rectifiers has been added. The chapter on vacuum tubes has been completely revamped to include a discussion of oxide-coated and thoriated filaments, water cooled tubes, reducing tube capacity, Piezo-electric crystal, and typical tube constants. To the chapter on continuous-wave telegraphy has been added short-wave telegraphy. The question of distortionless amplification has been treated very thoroughly and such things as pushpull, radio frequency amplification, and balanced circuits have been explained.

The book is profusely illustrated and is really the last word in radio. The chapters on wavemeters and radio experiments have been omitted and the author says that if there is sufficient demand he will publish a separate book on these subjects. This book is still the bible for the radio student or experimenter.—R. W. A.

Marching Men: The Story of War. By Stanton A. Coblentz. The Unicorn Press. 1927. 6¼" x 9¼". 488 pp. Ill. \$5.00.

The title of this book is well chosen except in two essential respects; neither should it be called "Marching Men" nor is it a "History of War." The proper title would be "Prowling Beasts, An Outline of Atrocities." Apparently written as pacifist propaganda, the book defeats its own aim by the violence of its drumming of atrocities into the mind of the reader and by the utter exclusion of any other phase of warfare from its text. Such are the logical conclusions to be drawn from the book that one is inclined to think "was I wrong in the impressions brought back from France, or did I form part of a bloodthirsty mob that swarmed over France at the instigation of General Pershing, slaying women and children." There were *men* in France with General Pershing, but Mr. Coblentz seems to be unaware of that fact.

We start in the dim remoteness of antiquity and follow the War God from his rock throwing age until he reaches maturity in the great European holocaust. We touch briefly on each war until we come to Attila of the Huns, to the Khans, and to Napoleon at Moscow and then the minutest gruesome details roll out like choice morsels from the mouth of the story! Was there not a man named George Washington somewhere in history? One fails to find him—perhaps he had not those characteristics which the book desires to portray. It is true throughout that if there is no particular cruelty to describe, the phase of history in question

is passed by with the merest mention. The descriptions throughout of materials and methods of warfare form but a thin matrix to hold together the pieces of atrocity.

One does not desire war ever. Neither does one desire that distortion of fact and history, called propaganda, so excellently typified in this book. It cannot be conceded that there are no men and have been no men, in the world, but only beasts. *Marching Men* is neither an informative text nor an engrossing story.—B. F. H.

Texas and Southwestern Lore. J. Frank Dobie, Ed. The Texas Folk Lore Society. 1927. 6"x 9". 259 pp. \$2.50.

No section of the country is losing its flavor faster than the Southwest. This reviewer, who grew up in south Texas in the last quarter of the nineteenth century, finds difficulty in recognizing his own home town with its many automobiles and few horses, and particularly with the peace of its Saturday evenings undisturbed by the yells and pistol shots of the cowboy "come to town."

The Texas Folk Lore Society is making the laudable endeavor to preserve some of this rich, rare, and racy flavor, and appears to be astonishingly successful. The present volume, though interesting, is not quite up to the standard of the earlier publications. The most interesting and characteristically Southwestern contributions are *Folk Lore of the Texas-Mexican Vaquero*, by Jovita Gonzalez, and J. Frank Dobie's *Ballads and Songs of the Frontier Folk*. Mr. Dobie includes the complete text of the song, "Oh, Bury Me Not On the Lone Prairie," together with the text of its source, "The Ocean Burial," and makes this comment:

As I compare the verses of the original song with those of the cowboy imitation, the latter seems to me as much superior to the former as some of the songs retouched by Burns are to their originals. . . . I must confess that hearing this song sung affects me in the same way that the clink of spurs on gravel in the dead of night or the stamping of horses' hoofs and the flop of saddles on horses' backs in the silent, dewy morning before first dawn, have always affected me. . . .

To this reviewer the above is indicative of a proper spirit for the collecting of the lore of the old Southwest.

It is perhaps unfair to point out that a number of the songs, poems, and tales printed in the present volume are not truly Southwestern, but imported from the South of "before the War." Necessarily, this matter enters basically into the story and song of the Southwest, but it is authentic folk lore of that section only as modified, as revised, and remolded by the peculiar conditions encountered.

J. Evetts Haley, in *Cowboy Songs Again*, prints an old song entitled, "The Juice of the Forbidden Fruit," in the apparent belief that this song originated in a cow camp in the Davis Mountains in 1883. Mr. Haley states that it was based on a vaudeville ditty of which there were but a few lines and notes that this is an unusual ballad to have originated in a cow camp. The reviewer heard the entire song almost as printed sung by a traveling patent medicine troop "from the North" at least a year or two earlier than 1883. This is an example of the inclusion of something that in no sense belongs in the lore of Texas and the Southwest, and suggests the desirability of more careful culling.

Those interested in American folk lore in general and of the "wild and wooly" Southwest in particular will find the publications of the Texas Folk Lore Society both interesting and valuable.—R. S. A.