

THE COAST ARTILLERY JOURNAL

Features

Capture of the Baltic
Islands

—Green-Lanham

(AA) MG Fire Control

—Conway

The Day Before Can-
tigny

—Johnston

Adjustment of (AA)
Fire

—Harris

SEPTEMBER-OCTOBER
1936



THE MASSED BANDS OF THE

Report Documentation Page

*Form Approved
OMB No. 0704-0188*

Public reporting burden for the collection of information is estimated to average 1 hour per response, including the time for reviewing instructions, searching existing data sources, gathering and maintaining the data needed, and completing and reviewing the collection of information. Send comments regarding this burden estimate or any other aspect of this collection of information, including suggestions for reducing this burden, to Washington Headquarters Services, Directorate for Information Operations and Reports, 1215 Jefferson Davis Highway, Suite 1204, Arlington VA 22202-4302. Respondents should be aware that notwithstanding any other provision of law, no person shall be subject to a penalty for failing to comply with a collection of information if it does not display a currently valid OMB control number.

1. REPORT DATE OCT 1936	2. REPORT TYPE	3. DATES COVERED 00-09-1936 to 00-10-1936			
4. TITLE AND SUBTITLE The Coast Artillery Journal. Volume 79, Number 5, September-October 1936		5a. CONTRACT NUMBER			
		5b. GRANT NUMBER			
		5c. PROGRAM ELEMENT NUMBER			
6. AUTHOR(S)		5d. PROJECT NUMBER			
		5e. TASK NUMBER			
		5f. WORK UNIT NUMBER			
7. PERFORMING ORGANIZATION NAME(S) AND ADDRESS(ES) Coast Artillery Training Center, Coast Artillery Journal, Fort Monroe, VA, 23651		8. PERFORMING ORGANIZATION REPORT NUMBER			
9. SPONSORING/MONITORING AGENCY NAME(S) AND ADDRESS(ES)		10. SPONSOR/MONITOR'S ACRONYM(S)			
		11. SPONSOR/MONITOR'S REPORT NUMBER(S)			
12. DISTRIBUTION/AVAILABILITY STATEMENT Approved for public release; distribution unlimited					
13. SUPPLEMENTARY NOTES					
14. ABSTRACT					
15. SUBJECT TERMS					
16. SECURITY CLASSIFICATION OF:			17. LIMITATION OF ABSTRACT	18. NUMBER OF PAGES	19a. NAME OF RESPONSIBLE PERSON
a. REPORT unclassified	b. ABSTRACT unclassified	c. THIS PAGE unclassified	Same as Report (SAR)	82	

Gunners' Instruction

For all Coast Artillery Organizations. Fully meets the requirements of Training Regulations 435-310 (Examination for Gunners). Used for instruction in a number of R.O.T.C. units.

NUMBER	GUNNERS' INSTRUCTION I	PHLETS	PRICE
I.	2nd Class Gunner, Antiaircraft Artillery (Except Searchlight Battery).....		\$0.65
II.	2nd Class Gunner, Antiaircraft Artillery (Searchlight Battery).....		0.50
III.	1st Class Gunner, Antiaircraft Artillery (Except Searchlight Battery).....		0.65
IV.	1st Class Gunner, Antiaircraft Artillery (Searchlight Battery).....		0.40
V.	2nd Class Gunner, Fixed Seacoast Artillery (All Units).....		0.55
VI.	1st Class Gunner, Fixed Seacoast Artillery (All Units).....		0.50
	(All Tractor-Drawn and Railway Units).....		0.65
VII.	2nd Class Gunner, Mobile Seacoast Artillery		
VIII.	1st Class Gunner, Mobile Seacoast Artillery		
	(All Tractor-Drawn and Railway Units).....		0.75
IX.	Expert Gunner, Antiaircraft Artillery		1.00
X.	Expert Gunner, Fixed Artillery		1.00
XI.	Expert Gunner, Mobile Seacoast Artillery		1.00
XII.	Submarine Mining		1.25

These pamphlets recently have been revised and brought up-to-date. They cover the instruction of all 2nd Class, 1st Class, and Expert Gunners of Antiaircraft, Fixed and Mobile Artillery.

Invaluable for the training and instruction of Coast Artillery personnel. Each enlisted man of a submarine mine detachment should have a copy of "Submarine Mining."

The above prices are retail (postpaid) for single copies. To ORGANIZATIONS of the military establishment a discount of 20% will be allowed on any order regardless of number, F.O.B. Washington, D. C.

Automotive Transportation for the Military Service

By CAPTAIN JOHN T. DECAMP, C.A.C. and 1ST LIEUT. LEW M. MORTON, C.A.C.
Instructors in Motor Transportation, Coast Artillery School

HERE is a concise, technical discussion made available to the service at a time when such a book is in considerable demand. This one volume covers all necessary information concerning the design, operation and maintenance of automotive transportation issued to the military service. The text has been reviewed and approved by Professor Erwin H. Hamilton, B.S., M.E., of New York University, acknowledged authority on automotive engineering.

Here are the Titles of 31 Fact-Filled Chapters:

Outline of Automotive Vehicle Construction.	Engine Test and Performance.
Explosive Cycles and Firing Orders.	Diesel Engines.
Cylinders, Pistons and Piston Rings.	Clutches and Transmissions.
Connecting Rods, Crankshafts and Fly-Wheels.	Universal Joints, Drive Shafts, and Differentials.
Valves and Valve Operating Mechanisms.	Rear Axles, Frames, Springs, and Shock Absorbers.
Valve Timing.	Brakes.
Crankcase Lubrication.	Front Axles and Steering.
Engine Cooling Systems.	Tires, Rims and Wheels.
Fuel and Fuel-Feed Systems.	Engine Overhaul.
Elements of Carburetion.	Automotive Vehicle Troubles.
Carburetors.	Painting.
Elementary Electricity and Magnetism.	Convoys.
Storage Batteries.	Organization and Supply.
Battery Ignition Systems.	Methods of Inspection.
Starting Motors, Generators, and Lighting Systems.	Automotive Maintenance.
Theory of Internal Combustion Engines.	

Prices are retail, postpaid.
On any order for 10 or more copies a discount of 10% is allowed F.O.B. Washington.

PRICE

Durable Paper Binding, \$2.50
Leatherette Binding . . 3.00

This book is not a revision of "Military Motor Transportation." It is a new book compiled from authoritative sources.

THE COAST ARTILLERY JOURNAL

Member Affiliated Military Magazines

Published as the Journal of the U. S. Artillery from 1892 to 1922

LIEUT. COL. E. E. BENNETT, C.A.C., Editor

VOLUME LXXIX

SEPTEMBER-OCTOBER, 1936

NUMBER V

Publication Date: October 1, 1936

Contents

The Invasion and Capture of the Baltic Islands.....	323	News and Comment	369
By Lieutenant Colonel Fred M. Green, and Captain C. T. Lanham.		Activities of Association Chapters—School Staff and Student Officers, C.A.C.—Magnificent—Here Is Your Chance—Editors Come and Go—Coast Artillery Na- tional Guard.	
Warfare in the 18th Century—IV	336	Coast Artillery Activities	373
By Lieutenant Colonel J. M. Scammell, N.G.U.S.		Fort Monroe News Letter—Hawaiian News Letter— Corregidor News Letter—Panama Canal Department News Letter—Fort Barrancas Notes—Harbor De- fenses of Sandy Hook.	
Antiaircraft Machine Gun Fire Control—1936	339	Gas on a Hostile Shore	380
By Major E. T. Conway.		By Major Alden H. Waitt.	
Curves and Fast Balls at Leavenworth.....	344	Notes on Active Duty Training	383
By Major E. D. Cooke.		Foresight and Hindsight—Training of the 627th— Training of the 244th—Active Duty Training at Fort Sheridan—Training of the 619th—Basic Thoughts— Testimonial Dinner.	
The Day Before Cantigny	347	Coast Artillery Board Notes	391
By Major Edward S. Johnston.		Coast Artillery Orders	392
Adjustment of Antiaircraft Gun Fire.....	358	Foreign Military Press	395
By Major C. S. Harris.		By Lieutenant Colonel Alexander L. P. Johnson.	
Trophies	363	Book Reviews	397
Meeting of the U. S. Coast Artillery Association.....	365		
The Backbone of the Army	367		
By Major Joshua D. Powers.			
The Advanced Course Student	368		
By Major Frank L. Pearson.			

THE COAST ARTILLERY JOURNAL IS NOT RESPONSIBLE FOR OPINIONS EXPRESSED IN PUBLISHED CONTRIBUTIONS

THE COAST ARTILLERY JOURNAL pays for original articles upon publication.

Published bi-monthly under the supervision of the United States Coast Artillery Association for the information of the Coast Artillery personnel of the Regular Army, National Guard and Organized Reserve.

Publication Offices, 1406 East Franklin Street, Richmond, Virginia; Editorial Offices, 1115 17th Street, N.W., Washington, D. C.

Terms: \$4.00 per year. (Coast Artillery Association members, \$3.00 per year.) Single copies, 75 cents.

Entered as second class matter at Richmond, Virginia, under the Act of March 3, 1879, for mailing at special rate of postage provided for in Section 412, Act of October 3, 1917.

Copyright, 1936, by the United States Coast Artillery Association.

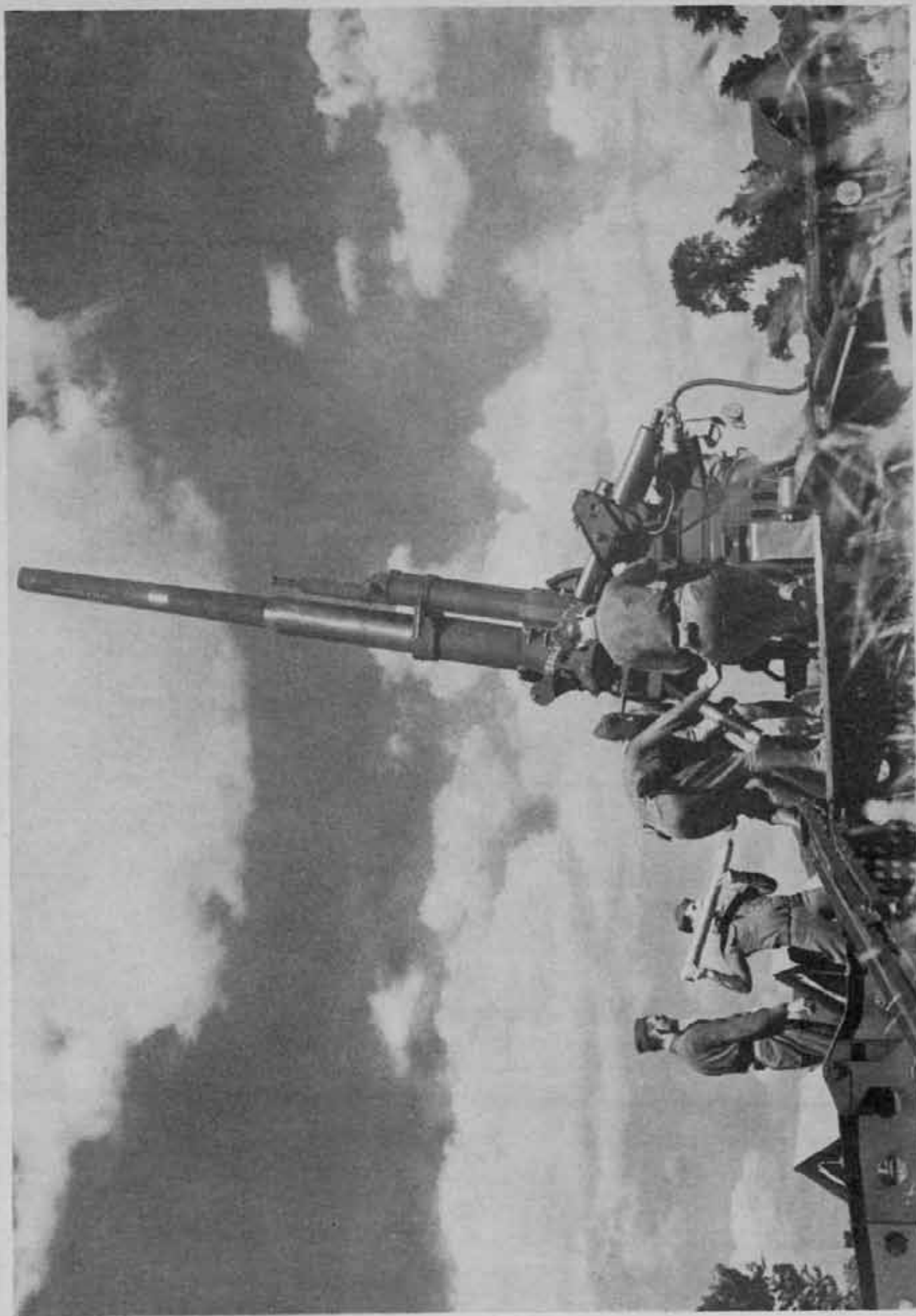

The Higher They Fly, the Harder They Crash

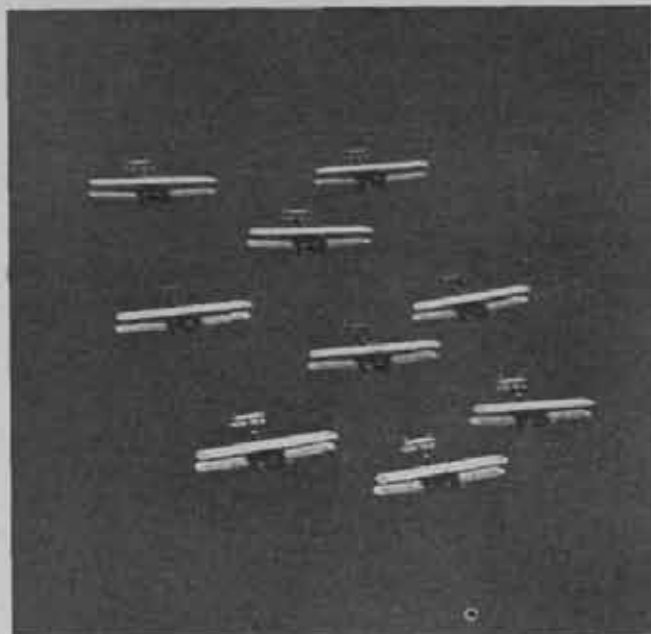

Paper of March 4, said: "The range of territory on the continent from which air attacks would be launched against this country is constantly extending and will continue to extend."

This new conception of an "Air Defense Frontier" makes necessary radical changes in the plans for the defense of every country in the world. A hostile air force may be based in regions inaccessible to the Navy, or may be so strong and well secured that the Navy cannot operate within its radius of action. In either case, the Navy cannot serve as the first line of defense. Counter air force action only can be employed to oppose such a threat and counter air force operations must be the responsibility of the land-based Air Force. Today, the frontier for this Force extends one thousand miles out from our sea coasts

LEFT—*Javelin Formation.*

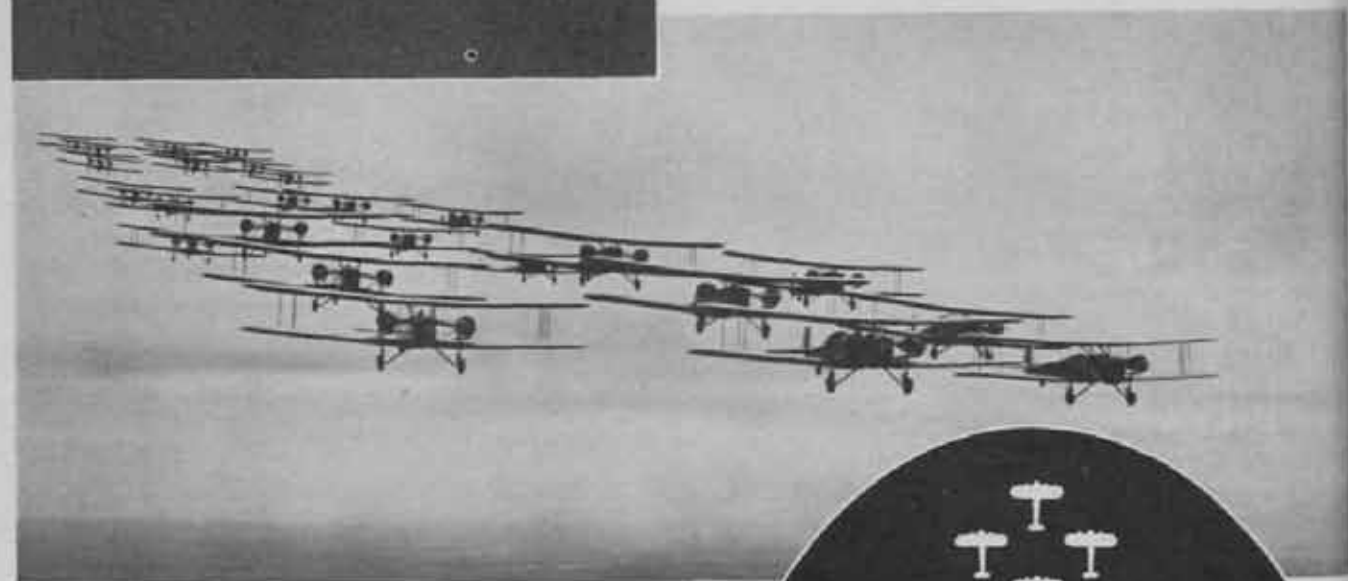

ABOVE—*Close Group Formation.*
RIGHT—*Group Wedge Formation.*

3. Load capacity.
4. Ceiling.
5. Flying qualities.
6. Ease of maintenance.

The range of the bombardment airplane has been increased within the past three years from a few hundred miles to more than a thousand. Technical developments indicate that this range, with an effective bomb load, may be greatly extended within the next two years. The effect of this increase in range of the bombardment airplane is to extend the frontiers of every nation in the world, in so far as the national defense is concerned.

Last summer during a speech on air armament, Stanley Baldwin, acting Prime Minister of Great Britain, said: "Since the day of the Air, the old frontiers are gone; and when you think of the defense of England, you no longer think of the white cliffs of Dover, but you think of the Rhine. That is where, today, our frontier lies."

Prime Minister J. Ramsay MacDonald, in his White

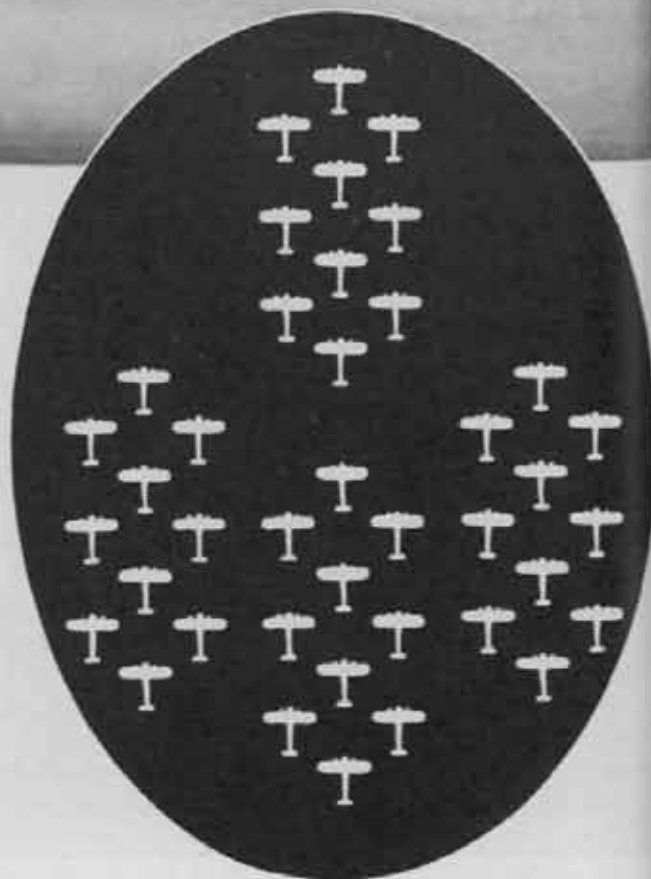

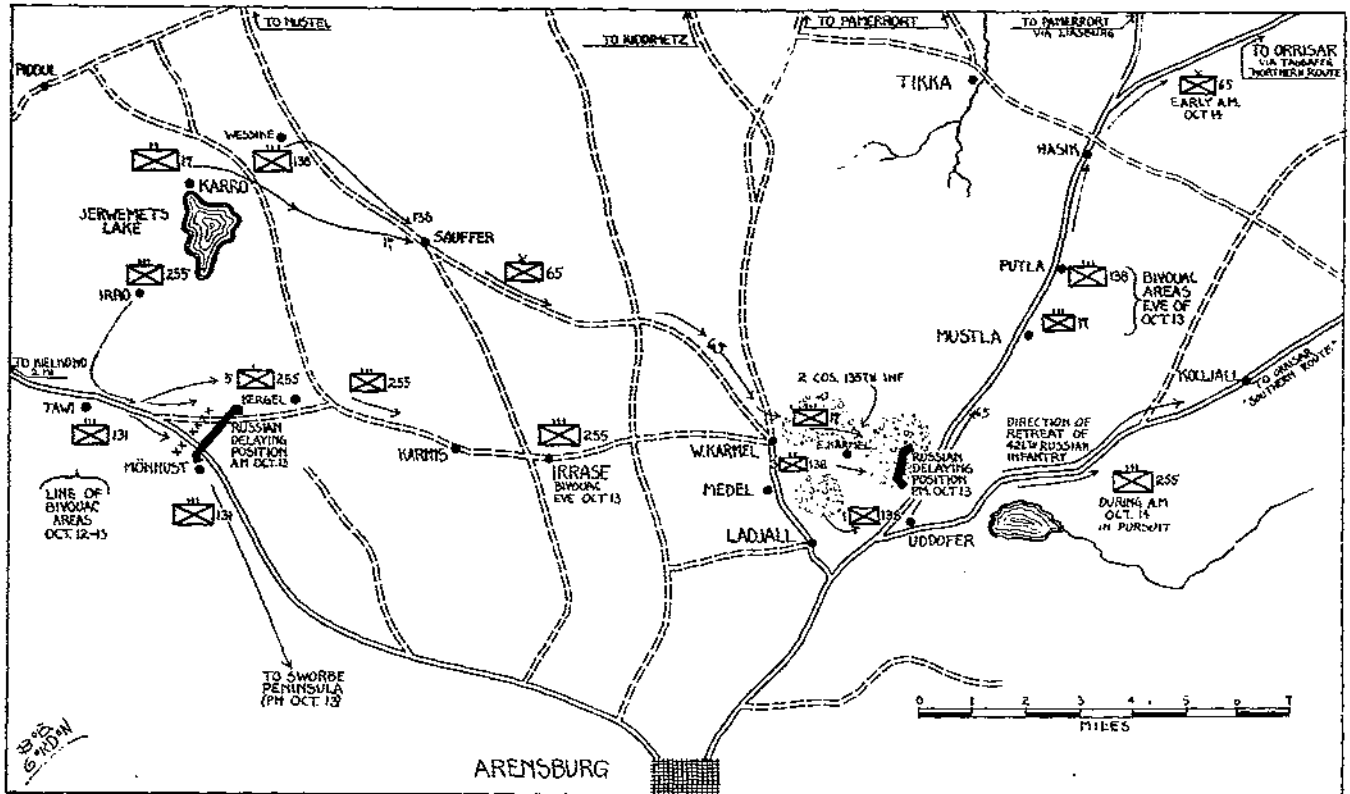

Map No. 5.

in division reserve, was to halt at Mönhus (13 miles northwest of Arensburg) pending the results of a cyclist reconnaissance toward Sworbe Peninsula.

The 255th Infantry, marching at 5:30 A.M. from its bivouac at Irro, passed the 131st Infantry at Tawi and made contact with the Russian delaying positions along the line Kergel—Mönhus. It was here that the enemy's light and medium artillery had halted the 131st Infantry the night before (Part I). By 11:00 A.M. the 5th Company had gained a position on the Russian right flank and the line was then rolled up without difficulty. One hundred and fifty prisoners and five machine guns were captured in the process.

The rapid Russian withdrawal was undoubtedly due in part to the discovery that the 65th Infantry Brigade had passed Sauffer, and therefore threatened the defenders' only route of retreat.

At 3:30 P.M. the 255th Infantry reached Irrase, somewhat exhausted and considerably short of its assigned march objective. To add to its difficulties, just before dark a Russian cavalry force, driving up from the south, attempted to cut its way through the regiment. The attempt failed, the entire force being killed or captured. With the termination of this affair the 255th sent out its attached cyclist company to maintain contact with the withdrawing Russians and forthwith settled into a dismal bivouac in Oesel Island's particular brand of mud.

* * *

At about 9:30 A.M. the 17th and 138th Infantry met at Sauffer, and marched southeast as a brigade. The advance guard, consisting of the 138th Infantry (less 2d

Battalion) and 6th Battery, 8th Field Artillery, reached Karmel-West at noon, and halted for a rest. Here it was learned that the 1st Cyclist Battalion was having its troubles; one company was reported hotly engaged at Uddofer, and two others at Kolljall. At both places strong hostile forces were attempting to break through to the northern route toward Orissar. It was also reported that Medel was strongly held by the enemy.

The 65th Brigade promptly resumed its march with the 3d Battalion of the 138th Infantry at the head of the advance guard. As the leading elements entered Karmel-East, they received heavy rifle fire from the woods north of Uddofer. Bold and aggressive action was instant. The 6th Battery whirled forward and, at a cost of many animals, went into position at a range of only 800 yards. The 1st Battalion (advance-guard reserve) divided, two companies moving to the north and one to the south, to attack both hostile flanks. (Don't try this at Leavenworth!)

Meanwhile the brigade commander, with the view of driving this force to the south, had ordered the 17th Infantry to envelop the enemy right. But before this regiment could enter the action, the advance guard had already taken the position, capturing 1,000 prisoners, 8 guns, and many machine guns. The remainder of the Russian 426th Infantry fell back toward the east.²

Although night had already fallen, the German advance continued. Not until Putla and Mustla were

²This was not the same force that had been dislodged from the Mönhus-Kergel positions by the 255th Infantry early in the day. It appears that the 426th Infantry, after its withdrawal from Tagga Bay, divided and deployed in the two positions described

reached did the brigade go into bivouac. The entire march had been executed under conditions of extreme difficulty. Neither the trains nor the artillery had come up. The men had had nothing to eat except what remained of the reserve rations they had brought ashore with them on the morning of the previous day. But despite these hardships, despite the fighting, the driving rain, the quagmires that passed for roads and the lack of even machine-gun carts in the way of transportation, they had made good progress, although they had not reached Hasik—the prescribed march objective. Nevertheless their position astride the north road from Arensburg to Orissar, effectually blocked that route of escape to whatever Russian troops might still remain at Arensburg.

* * *

Until well into the forenoon of the 13th, division headquarters believed that the Russians would probably attempt to concentrate their forces at Arensburg for a counter-attack. For this reason the division commander had ordered the 65th Brigade to push forward to the northeast and not allow itself to be contained by any hostile force operating in that vicinity.

During the day bad weather had hampered air observation and reports had been scarce. But just at dark a report was made by Warrant Officer (*Offizier-Stellvertz*) Meyer that rolled back a great deal of the Oesel Island fog. Meyer had been sent out with a patrol. He had led that patrol around the left flank of the Russian position at Mönust and had entered Arensburg. Arensburg, said Meyer, was free of Russian troops. Only an occasional straggler had been seen.

Here was an opportunity for an aggressive man and apparently Meyer was not lacking in aggressiveness. He promptly rounded up one Colonel Popoff, the town commandant, and demanded the surrender of the city. Colonel Popoff complied with alacrity and Warrant Officer Meyer found himself in possession of the keys to Oesel Island's metropolis. But this patrol leader was in Arensburg for information rather than keys so he did a little persuasive questioning of the estimable Colonel Popoff. His method would be highly instructive were it known, for it certainly produced results. Meyer learned that on the day of the German landing, division headquarters and ten to twelve thousand troops had left Arensburg for Orissar en route to Moon Island and safety. Five thousand others had pulled out at the same time for Sworbe Peninsula hoping to escape from Oesel on shipboard. Here was real news! Meyer sat down to write his report and get it off post haste. And then the unexpected happened. A wandering Russian detachment suddenly materialized out of nothingness and surprised and captured the entire German patrol . . . except one man. The man who escaped was, of course, the resourceful Meyer. By dark he had reached Kergel and made his report.

What did General von Esteroff think at this moment? At Orissar stood one German cyclist battalion! Twenty-five miles intervened. His troops were apparently close

to the edge of their endurance. The rain was torrential. The roads . . . well, Oesel Islanders called them roads. But at Orissar stood one German battalion and 12,000 Russian troops had been marching toward that town for more than twenty-four hours.

At 11:00 P.M. the air force brought in a message that was a logical sequence to Meyer's report. Said the air force . . . the 2d Cyclist Battalion at Orissar is hard pressed; the Russians appear to have captured the Oesel end of the causeway! In those moments that passed before he made his decision General von Esteroff must have wondered what had happened to the naval forces north of Oesel Island that were to cooperate with the cyclists at Orissar; he must have tried to visualize the progress his 1st, 4th and 5th Cyclists had made toward Orissar or had those three battalions been engulfed in the Russian flood. Finally he must have thought of his men.

They were thoroughly tired. After a more or less sleepless night afloat, they had landed at dawn, plunged into unknown forests, brushed aside all resistance, rapidly extended the beach-head to great depths, outposted the position for the night, started again at daybreak, made a forced march all day and fought two actions (one by each column). Now it was nearly midnight and the rain was falling in sheets. But against all this stood one great moral consideration: the cyclists could not be abandoned. General von Esteroff ordered bivouacs broken, packs left behind, and the forced march resumed. The 255th Infantry moved out on the southern road, while the 65th Brigade continued along the northern route.

The march was pushed with great resolution for the rest of the night, all the next day (and for the 255th Infantry almost to midnight the next night) through mud and pouring rain. On the best of the dirt roads, the mud was four to eight inches deep. On the poorer roads, the advance had to be made in columns of twos, the files clinging to the edges of what had been road.

This division marched and fought almost continually for the next 36 to 43 hours. The 65th Brigade covered 22 miles in the last 9 hours of the march. The 255th Infantry marched 42 miles, covering the last 32 in 24 hours. Not even the brigade commander had a mount.

We must leave these troops as they start their magnificent march on Orissar and turn to the joint action against the fortified Sworbe Peninsula.

* * *

THE SWORBE PENINSULA

By noon, October 13, General von Esteroff was satisfied that he could safely divide his forces. Accordingly he detached the 131st Infantry (which he had held in division reserve at Mönust during the morning) and ordered it to capture the Sworbe Peninsula.

That evening the regiment bivouacked at Tehomardi (Map 6) where it was overtaken by its combat train and by the 5th Battery, 8th Field Artillery. The vil-

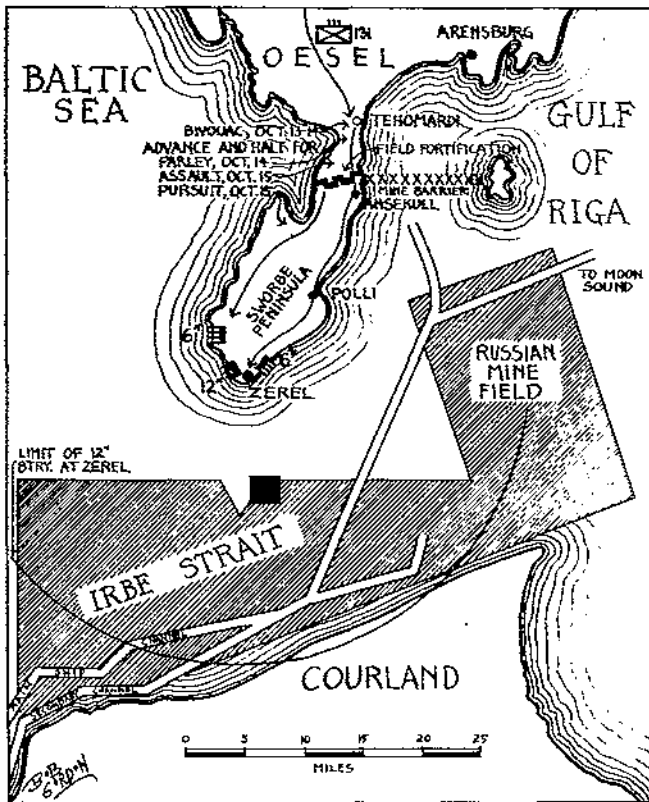

Map No. 6.

lagers confirmed the German belief that the peninsula was garrisoned by one Russian regiment.

Realizing the demoralization in the Russian ranks, the colonel of the 131st believed that he could induce this force to surrender. At any rate he decided it was worth a try. Therefore at 8:00 A.M. the next morning he halted his regiment a few miles north of the Russian position at Ansekull and sent forward his proposition under a flag of truce.

For five hours he waited for a reply that never came. At the end of that time he saw five Russian destroyers steaming for the eastern side of the peninsula. The colonel waited no longer. These destroyers must be coming in for one purpose—to evacuate the Russian garrison. The 131st resumed its advance. Two hours later the column was brought to an abrupt halt by rifle and artillery fire from the fortified Russian position near Ansekull. Russian troops swarmed over the works, improving and extending the position.

While German patrols worked forward to reconnoiter the enemy, the reserve battalion swung wide to the right in search of a position from which it could envelop the hostile left. The remainder of the regiment took cover, to escape the punishing fire of the two Russian field batteries that supported the defense. The single battery that accompanied the German regiment had a real job on its hands: it was outnumbered two to one; it had only 300 rounds of ammunition; and it could not locate an O.P. from which its fire on the defiladed hostile artillery positions could be observed.

There were other difficulties. The German commander

had managed to get a radio message through to the fleet requesting supporting fires. The fleet had agreed to station the *Friedrich der Grosse* off the isthmus to fire on the position and to use destroyers for counter-battery missions. And then the radio failed as it had repeatedly failed. Coordination became impossible. The destroyers did some firing but the battleships were not heard from.

The German colonel did not like the situation. Night was coming on. His reserve battalion was not yet in position to launch an envelopment. His radio was out. Purportedly reliable information received during the afternoon placed the Russian garrison at much more than one regiment. All in all the prospect was not pleasing and the hour late—therefore, said the colonel, we will postpone the attack until morning.

While the 131st Infantry goes into bivouac and the staff wrestles with its plan for the morning attack on Ansekull let us see what the naval forces south of Oesel Island have been doing.

* * *

Entrance to the Gulf of Riga via Irbe Strait was denied the German Navy by dense and extensive mine fields which were overlapped, except at the extreme southwest end (Map 6), by the fire of the seacoast armament on Sworbe Peninsula. Moreover, the 12-inch guns at Zerel outranged the main batteries of the German battleships. Little mine-sweeping could be undertaken until the Sworbe batteries had been destroyed or captured.

On October 11, a day of low visibility, an attempt to reconnoiter the channel entrance had been greeted by long-range fire from the Sworbe guns. On the next day, while the landings were being made at Pamerrort and Tagga, the *Friedrich der Grosse* and the *König Albert* demonstrated against the peninsula. During this bombardment (from positions about 18,000 yards to the northwest) the major caliber armament of the ships fired on the 12-inch battery at Zerel, while the naval torpedo-defense guns fired on the enemy's 6-inch batteries. For some reason the Russians did not return this fire. Taking advantage of this inactivity and the low visibility, the Germans pushed their mine-sweeping operations vigorously all that day and the next.

The German Navy had expected the Sworbe batteries to be taken from the land side shortly after the army completed its landing at Tagga Bay. This estimate was reasonable at that for the 131st Infantry had reached the peninsula on the morning of the 14th but they lost five hours by halting for a parley.

On the 14th the navy again bombarded the seacoast works in an effort to divert the enemy's attention from the approaching land attack. At the same time the mine-sweepers kept to their work. Being more than 29,000 yards from Sworbe, these small craft were practically invisible. But not the cruisers that guarded them from submarine attack, for they were picked up by the Sworbe batteries during the morning and driven out of range. In the afternoon the communication system be-

tween the German army and navy broke down completely and with it went all hope of coordination. A garbled and incomplete message from an infantry radio set led the navy to believe that an infantry assault was impending. The navy was uncertain as to how it could help but at a venture ordered three battleships to bombard the seacoast works at ranges from 22,000 to 13,000 yards. This time the 12-inch battery came to life with a rapid and accurate reply. The bombarding ships, outranged by this battery, and threatened by submarine attack as well as by fire of the harbor-defense armament, were forced to maneuver at considerable intervals, on irregular courses, and at high speed.

And so we come to the morning of the 15th, the attack of the 131st Infantry and a curious amphibian situation. During the artillery preparation for this attack, German destroyers from the Baltic side of the isthmus delivered counter-battery fire on the two Russian field batteries that supported the defense at Ansekull while Russian destroyers from the gulf side of the isthmus shelled the German battery and harassed the reserve of the 131st Infantry.

All during the morning of the 15th the Sworbe guns remained silent. About noon naval observers saw clouds of smoke rise over the seacoast batteries and later on heard explosions. The Fourth Battle Squadron at once closed in and bombarded the batteries for an hour, but could elicit no reply. This led to a suspicion, soon to be verified, that the Sworbe batteries no longer constituted a menace to the passage of Irbe Strait.

What had happened? This had happened.

During the night of October 14-15 a virtual mutiny had taken place in the Sworbe garrison. Prisoners stated that their officers had made great promises of reinforcements. They had been led to believe that several Russian divisions were coming to their assistance from the mainland and that naval reinforcements were en route to Sworbe from the bases along the Gulf of Finland. The failure of this promised help to materialize, the general decline of discipline, and the effect on the "soldiers' council" of the terms offered by the 131st Infantry under the flag of truce, all combined to destroy the Russian will to resist.

Thus, when the 131st Infantry attacked the Ansekull position at about 10:00 A.M. they encountered no more than a perfunctory defense. Indeed, before the assault was well launched, it turned into a pursuit. All day the 131st Infantry pushed southward after the erstwhile Ansekull defenders. Meanwhile the German Navy continued to bombard the seacoast works. Sometime around noon the Russian gun crews disabled their batteries and fled.

Late that afternoon the commander of the Russian fleet learned that the Sworbe fort was being abandoned and was certain to be captured. Hoping to disable the armament, so as to prevent its subsequent use by the Germans, he sent the battleship *Grashdanin* to bombard the evacuated works. The *Grashdanin* closed in to point-

blank range and poured salvo after salvo into the abandoned works until it received word from the commandant at Sworbe that these batteries had already been rendered useless. These batteries had been repeatedly bombed by German planes, had undergone several bombardments by German battle squadrons, and finally had been subjected to this pointblank and unopposed bombardment by a Russian battleship. What was the result? As far as crippling the guns was concerned, the result was nil! Although extensive internal demolitions had been prepared in the long-range battery, only one had been actually fired. However, the retiring garrison damaged the magazines, searchlights, power plant, and antiaircraft armament to such an extent that they were now useless. The crews had disabled the guns by carrying off essential parts of the breech blocks.

The threat of the Sworbe armament was now at an end. Save for the mine fields, Irbe Strait lay open to the invading fleet whose subsequent activities we shall follow a little later. On October 16 all Russian troops on the peninsula surrendered. The German account states that 120 officers, 4,000 enlisted men, and 49 pieces of artillery fell to the 131st Infantry.

Although the Sworbe action appears overwhelmingly successful, the Germans were displeased with it on two counts.

(1) Before the surrender, the Russians had disabled their seacoast armament permanently. This left Irbe Strait open to naval reprisals and left the Gulf of Riga insecure.

(2) Coöperation between the army and navy had been almost non-existent throughout the operation. The field radio sets of the infantry had repeatedly broken down. Even when working, they had not proved effective in reaching the navy. Visual signalling from shore to ships had failed to produce results. Different codes and ciphers by the two services had rendered confusion worse confounded. At least three times during this operation the failure in communications prevented mutual understanding and coöperation. In particular did it keep the 131st Infantry from receiving the help that the navy could have so easily given.

All in all, then, the Germans were disappointed in their conduct of this action despite its fortunate outcome.

While the mine-sweepers are opening Irbe Strait for the impatient German fleet we shall leave Sworbe Peninsula and move to the critical bottle-neck at Orissar.

THE FIGHT AT ORISSAR

It will be remembered that four companies of the 2d Cyclist Battalion had made a 26-mile forced march along the shore road from Pamerrott to Orissar and by 9:00 P.M. on the day of landing had seized the nearer end of the Oesel-Moon Causeway (Map 7). The other two companies of this battalion had moved as a right-flank guard along the roads further south while the attached Assault Company and its machine-gun platoon, finding no work for it at the mythical battery reported at Pamer-

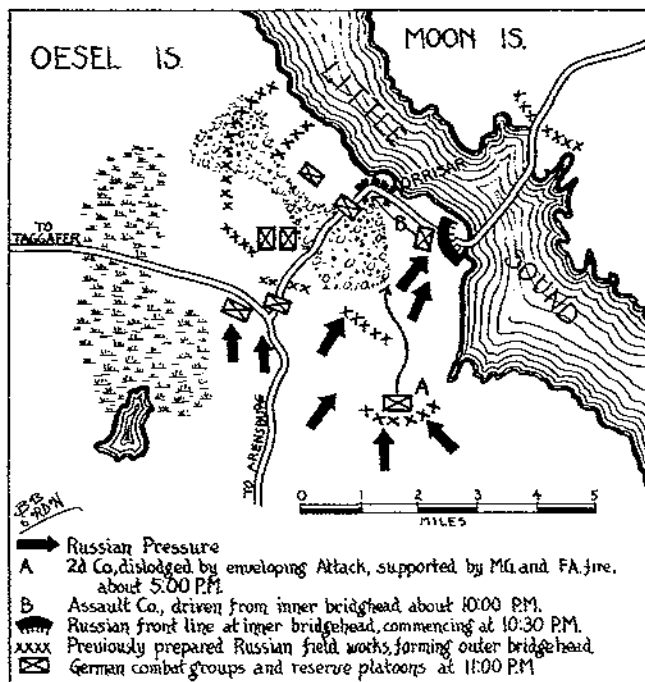

Map No. 7.

port, had seized enough farm vehicles to carry its equipment and hurried for Orissar. By noon of the next day these last three companies had reached the causeway and gone into position.

The Russians held the Moon Island end of the causeway and the cyclists the Oesel end. The German position covered the causeway itself and all approaches from the Oesel end.

Hostile approach whether from east or west could only be made in column; either along the causeway from the east or along the narrow roadway through the marshes from the west. But both to the north and the south lay open country and from either of these directions the Russians could bring their full force to bear against the cyclists. True the fortifications which the Russians themselves had prepared for the outer defense of the causeway afforded the little German force some comfort against this threat. But on the other hand, they knew that they were too few to long withstand a determined attack that could drive in from front, rear and both flanks.

But then, thought the cyclists, our naval forces north of Oesel Island will show up in Little Sound in a matter of hours; the 1st Cyclist Battalion that landed with us and marched south to delay the enemy will be in any minute, and the 4th and 5th Cyclist Battalions can't be far behind them. We'll make out. And with what comfort they could derive from this they snatched a few hours' sleep after their 26-mile grind.

On the morning of October 13 an unsuspecting Russian supply train materialized out of the early mist and was promptly captured. This train had been sent from Arensburg without escort for the Russians were unaware of the fact that a determined German battalion stood squarely across their line of communications. Later in the morning scattered groups of enemy troops began to

filter up from the southwest. Some of these were surprised and captured. By 2:00 P.M. the cyclists had taken about 500 prisoners—a considerable problem, incidentally, for a force less than twice that size. A short while later several military automobiles and a sanitary company were gathered into the net, but after that the alarm spread, and there were no more easy captures. The retreating Russian trains halted at a safe distance while small infantry groups began to work around the southern flank of the German position, seeking some avenue of escape to Moon Island. As the day wore on the enemy became stronger and his aggressiveness increased.

By this time the strength of the German force, which had not yet been joined by its two field guns, could not have exceeded 700 or 800 men. It was attempting to hold a semicircular front of almost seven miles. At the same time it had to repulse repeated attacks against its rear by the Russians on Moon Island. These attacks, well-supported by artillery at close range, were vigorously driven forward in an effort to open the causeway.

On the Oesel side, the situation of the over-extended German force became increasingly difficult. Small hostile parties slipped through the thinly-held line and attacked the German combat groups on all sides.

By evening the Russian fugitives in front of the position had become numerically overwhelming. Attack after attack was launched, and although these were never pushed home with great resolution, their cumulative effect began to be felt. Slowly but surely the German left was being driven back upon the causeway. Meanwhile the attacks from Moon Island became increasingly vigorous. At about 10:00 P.M. the Assault Company, which had been defending the inner bridge-head, exhausted its ammunition and was forced back in the direction of the village of Orissar. Russians from Moon Island then streamed across the causeway and began to establish a position in the fortified inner bridge-head on the Oesel Island side.

During the night of October 13-14 the fighting was furious and the situation became increasingly critical. Over-extended, split up into small detachments between which Russian troops were infiltrating, with vastly superior forces of the enemy attacking them in front and rear and control of communication across the dam pretty well lost, the destruction of the German force appeared inevitable.

What had happened to the navy? What had happened to the 1st, 4th and 5th Cyclist Battalions? How long could this single battalion stand against such overwhelming odds? On Oesel Island the Russians outnumbered them 15 to 1; on Moon Island 10 to 1. Sandwiched between these two forces, one German battalion fought for its life. And so passed the night of October 13-14.

At daybreak the next morning the Russians renewed their attacks. Artillery and machine-gun fire raked the German position. Casualties piled up. Hour after hour

the tide of battle surged back and forth. And then, just when it seemed the German line must break—the pressure suddenly eased. The 5th Cyclist Battalion had wheeled into the fight near Orissar! Roads ankle-deep in mud had delayed them.

Although the lack of coördination in the Russian assaults had so far saved the cyclists, their situation was still perilous. The Russian forces on the Oesel side were increasing rapidly not only in strength but in desperation. Moreover, fire was now being poured into the cyclists from light batteries just across Little Sound, from the Russian fleet in Moon Sound, and finally from the seacoast batteries at Woi. Even with their recent reinforcement, gaps 200 to 1,000 yards still existed in the German line. Elsewhere it was so lightly held that it would have to go down before any determined assault. This was a stop-gap—a fist in the dyke. More men were needed and needed fast. And at 2:00 o'clock they came. Down the Taggafer road, splattered with mud, panting from their exertion, pedalled the 4th Cyclist Battalion. Instantly they were rushed into the great gap on the threatened German left (Map 8). And even as they went into position the Russian attack struck them. This new attack was launched in four waves and pushed home with a degree of resolution hitherto lacking. At the same time the Russians at the inner bridge-head drove forward against the German rear, their attack supported by several armored cars. Against these vehicles the cyclists had no weapons likely to be effective. How they must have cursed the lack of the two field guns which they had been unable to land at Pamerrort. By desperate expedients and frantic improvisation the Germans held. For two hours they beat off the continuing assaults and then, at 4:30, the inevitable happened—*ammunition ran out!*

Where *was* the Navy? They were charged with supply. What had happened to them? To answer that question we must leave the cyclists in their hopeless situation and turn to the adventures of the light naval forces operating north of Oesel Island.

NAVAL PENETRATION OF KASSAR BAY (Map 9)

The light naval forces north of Oesel Island had a threefold mission: (1) to prevent Russian naval raids against the German fleet in and about Tagga Bay; (2) to reconnoiter routes through Kassar Bay into Little Sound, thus permitting the support and supply of the 2d Cyclist Battalion; and (3) later to assist the army in forcing a passage to Moon Island.

While the Secondary Landing Force was being put ashore on the beaches west of Pamerrort, light naval craft were already reconnoitering the entrance into Kassar Bay to discover and open a route into Little Sound. While the landing was still in progress, these trawlers were attacked by two Russian destroyers and forced to withdraw through Soela Sound and take refuge under the guns of the *Emden*.

At 2:00 P.M. the German destroyers that had been

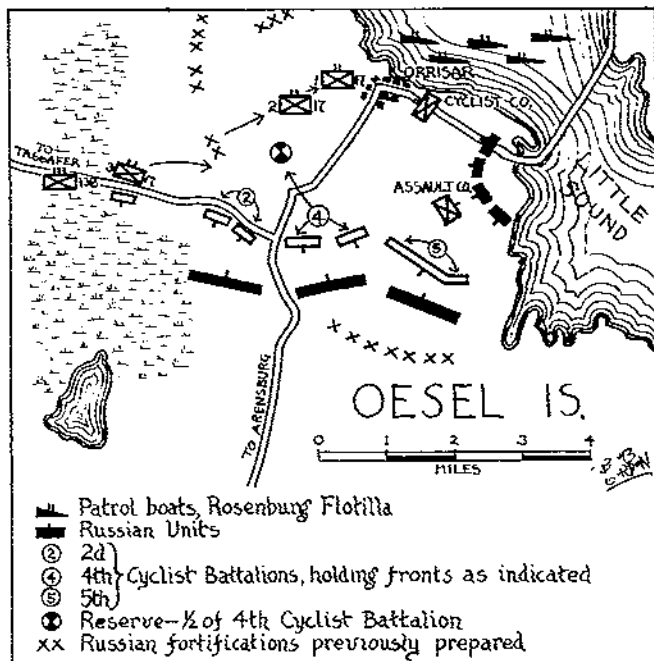

Map No. 8.

bombarding Kielkond and Papensholm steamed into Soela Sound and the reconnaissance was resumed. This time the trawlers were escorted by six destroyers and six small torpedo boats. In Kassar Bay this flotilla met four Russian destroyers and a gunboat, and drove them east into Moon Sound, where the Russians fell back on the cruiser *Makaroff* and five additional destroyers. The superior weight and range of the Russian armament promptly turned the tables and the Germans were forced to withdraw without entering Little Sound or gaining contact with their troops ashore. So ended their efforts on October 12.

The next morning eight Russian destroyers near the channel entrance precluded any chance of reconnaissance. The *Emden* tried to put matters right by working in as close as she dared, but despite her best efforts she could not take the Russian ships under fire. A fruitless artillery duel followed. Patchy fog added to the obscurity of the situation. By afternoon this fog had become so dense that it paralyzed all naval activity for the rest of the day.

The situation in Kassar Bay was maddening to the German Navy, which found itself balked in all its active missions. To the east, in Moon Sound, Russian naval superiority was unquestioned while west of Soela Sound the Germans enjoyed a similar supremacy. The narrow channel through the shoal waters of Kassar Bay would admit none but the smallest and most shallow-draught vessels. Thus, this bay formed a naval no-man's-land in which neither side could definitely establish itself.

The Germans faced a real problem. By day the superior gun-power of the Russian fleet in Moon Sound prevented the light German flotilla from approaching Little Sound. Torpedo attacks on the Russian fleet by night were rendered impossible by the shallowness of the water.

A third matter had to be faced. Although the Rus-

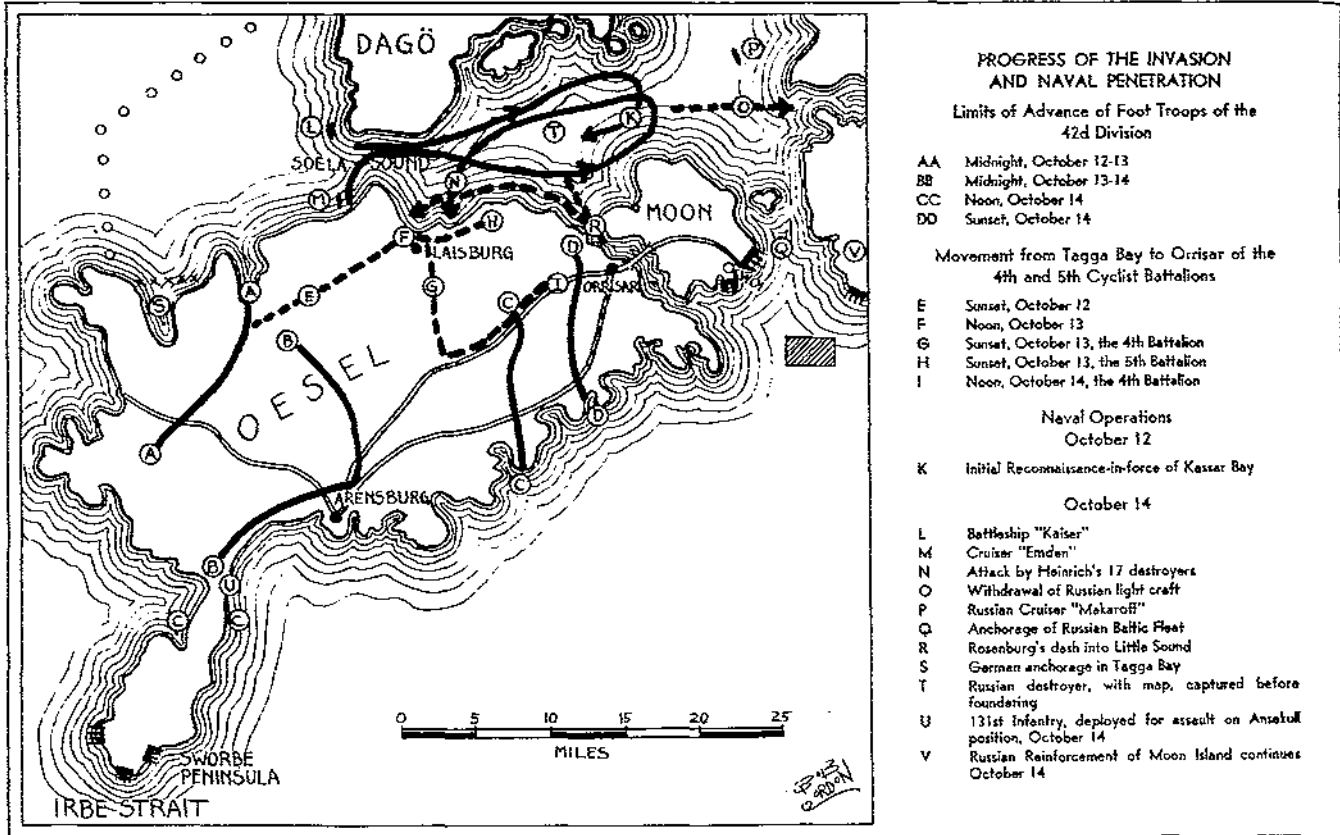

Map No. 9.

sians had been unexpectedly dilatory in removing range-marks and channel buoys from Kassar Bay and had failed to mine or obstruct the channel, it was reasonable to suppose that they were now tardily accomplishing those very things under cover of fog. As a matter of fact, the Russians had deliberately left this channel open and well buoyed in order to preserve a sortie route for themselves, believing that German craft would find it impossible to navigate these difficult waters anyway. However, the determined German effort to penetrate this opening caused the Russian naval commander to regret his former decision, and on the nights of October 12-13 and 13-14 he made unsuccessful attempts to have the channel mined. His failure was occasioned by mutiny on his mine planters. The crews, fearing that the waters had already been mined by the Germans, flatly refused to undertake the missions. (On the third night, October 14-15, the planters, manned by destroyer crews, finally laid a mine barrier, but failed to carry it close enough to the Oesel shore to be truly effective.)

By the morning of October 14 the German destroyer flotilla had been strongly reinforced. About noon, supported by overhead fire from the battleship *Kaiser* and the cruiser *Emden*, 17 German destroyers entered Kassar Bay, attacked two Russian gunboats and 11 destroyers, and in a three-hour battle drove them back on the Russian cruiser *Makaroff*. During this action three German destroyers were badly damaged and one was sunk (one ran aground and three were struck by mines). One Russian gunboat went down and one of their newest

and fastest destroyers was disabled, abandoned and quickly captured. On this destroyer the Germans found a map showing the location of Russian mine fields off Woi. This ship had been caught squarely by a large shell from the *Kaiser* and despite the Germans' efforts to save her she finally capsized. The captured chart was a real find and was to prove its worth some time later off the southern entrance of Moon Sound.

But the major success of the German Navy on this day lay elsewhere. While the enemy's attention was engaged by Commodore Heinrich's aggressive destroyers, Commander von Rosenberg's shallow-draught scouting boats slipped into Little Sound and by 2:30 P.M. reached Orissar. But although the navy had arrived, no one knew what to do for not a word of the cyclists' desperate situation had filtered through. Therefore Commander von Rosenberg did the only thing he could—he immediately dispatched a liaison officer to gain contact with the 2d Cyclist Battalion.

And so at 4:30 P.M., the exact hour at which the ammunition crisis had brought the cyclists to their last ditch, this liaison officer, this *deus ex machina*, dropped into their midst. The light torpedo boats had arrived, he said and would like to know how they could help. He got his answer in a hurry—small-arms ammunition as fast as the navy could get it in and then interdiction fire on the causeway and a warm artillery salutation to the Russian masses at each end.

The ammunition came ashore in a hurry but a communication delay and darkness prevented the second re-

quest from being carried out until the next morning.

In war it seems that the breaks, whether good or bad, all come at once. The cyclists had met and overcome their full measure of ill fortune and the scales now turned with a vengeance. On the heels of the liaison officer came the 6th Battery, 8th Field Artillery, and a battalion commander of the 17th Infantry who reported the arrival of the 65th Brigade.

The 6th Battery came forward at a gallop, went into position, and sent the Russians' armored cars scurrying back to Moon Island. The 17th Infantry, hurrying in from the Taggafer Road, attacked the inner bridge-head at about 5:00 P.M. and by 7:00 P.M. the Oesel end of the causeway was again in German hands. (Map 8.)

The 138th Infantry then came up and went into bivouac on the German right, extending the line from Little Sound to the swamps on the west. During the night three futile Russian attacks were launched across the dam while the light batteries on the opposite shore of Little Sound and the heavy guns from Woi and from the Russian fleet, kept up an intermittent fire. But their efforts were foredoomed; the chance of escape had gone.

Unknown to the 65th Brigade, with which all communication had been lost, the 255th Infantry arrived squarely in the Russian rear about midnight of October 14-15 (Map 10), after a march of 32 miles in 24 hours.

A night attack was clearly not in order. The situation was altogether unknown, the terrain unfamiliar and unrecognised, and the men of the 255th exhausted. Therefore the regimental commander wisely bivouacked his command along the road under cover of a march outpost.

Although the circle had closed, neither General von Esteroff nor the colonel of the 255th Infantry knew it. Indeed, the situation had not even clarified the next morning. Division headquarters was convinced that the Russian division had already made good its escape and that only a minor force remained at Orissar.

On the morning of the 15th confusion was universal. The 65th Brigade was unaware of the presence of the 255th Infantry and the 255th was equally in the dark as to the brigade. Fog and the uncoordinated efforts of the Russians to find some avenue of escape heightened the obscurity.

The 255th Infantry had other troubles: its small-arms ammunition, unreplenished since landing, was almost exhausted. So rapid had been the advance of this magnificent infantry that neither its combat wagons, its machine-gun companies, nor its attached artillery had yet caught up. The 65th Brigade found itself in similar straits. Late in the morning a full battery joined the brigade, giving it two batteries in all, and a half battery reached the 255th.

They came none too soon, for at 11:00 A.M. the division commander ordered the 65th Brigade to attack lest the Russians escape by water. Not until this attack jumped off did the colonel of the 255th have any idea of the situation. But with the opening salvos of the bri-

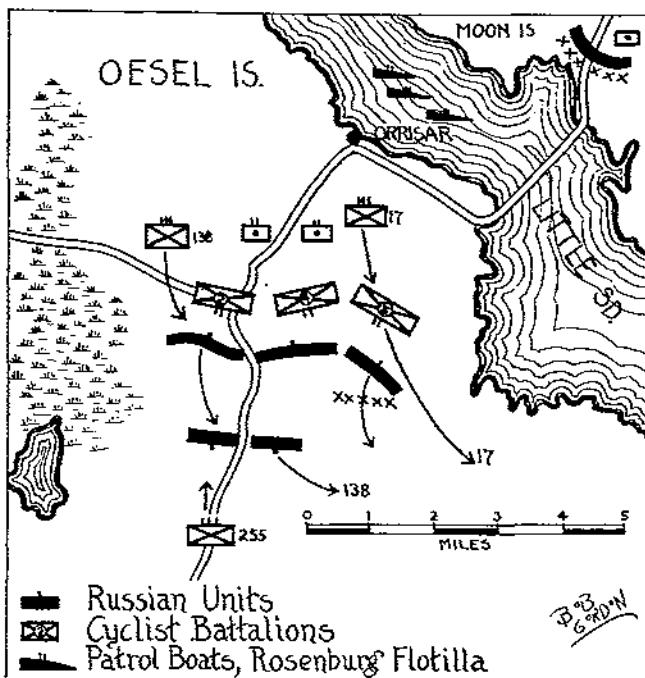

Map No. 10.

gade's two batteries he saw the picture as it actually stood and at once ordered his regiment to attack. Thus, at about 2:00 P.M., the 65th Brigade and the 255th Infantry jumped off in simultaneous but uncoordinated attacks. By 2:30 P.M. white flags were breaking out all along the Russian line. By 5:00 o'clock the capitulation was complete; the Russian 107th Division had ceased to exist (Map 10 shows the final German movement.)⁸

The fall of Oesel Island marked off part of the German mission: there still remained Moon Island and its garrison, and the Russian fleet in the Gulf of Riga. As we approach the final chapter of the invasion we must again return to that part of the fleet operating south of Oesel Island.

NAVAL ACTION IN THE GULF OF RIGA (Map 11)

As soon as the seacoast batteries on Sworbe Peninsula had been captured, the navy completed sweeping its channel through the mine fields in Irbe Strait. This work progressed so rapidly that during the morning of October 16 a German squadron entered the Gulf of Riga. Supply ships, under escort of a cruiser, were dropped off

⁸The close reader has probably noted that although the 2d, 4th and 5th Cyclist Battalions were duly accounted for, no mention was made of the 1st Battalion in the fight about Orissar. The 1st Cyclists undoubtedly fought the good fight there but the authors have been unable to find any record of it. On the night of October 12-13, four of its six companies held the northern road from Arensburg to Orissar while the other two companies tried to reach a position from which they could block the southern road. These two companies were driven out of range of the road on the next morning. During the 13th the entire battalion was driven off to the north. By the 14th it became apparent that the great mass of the Arensburg garrison was streaming up the southern road and that the 2d Cyclist Battalion was hard pressed. Thereupon the 1st Cyclists moved eastward with the idea of helping them but the heavy mud prevented them from getting beyond Taggafer. And at Taggafer on the night of October 14-15, the account of the 1st Cyclist Battalion ends.

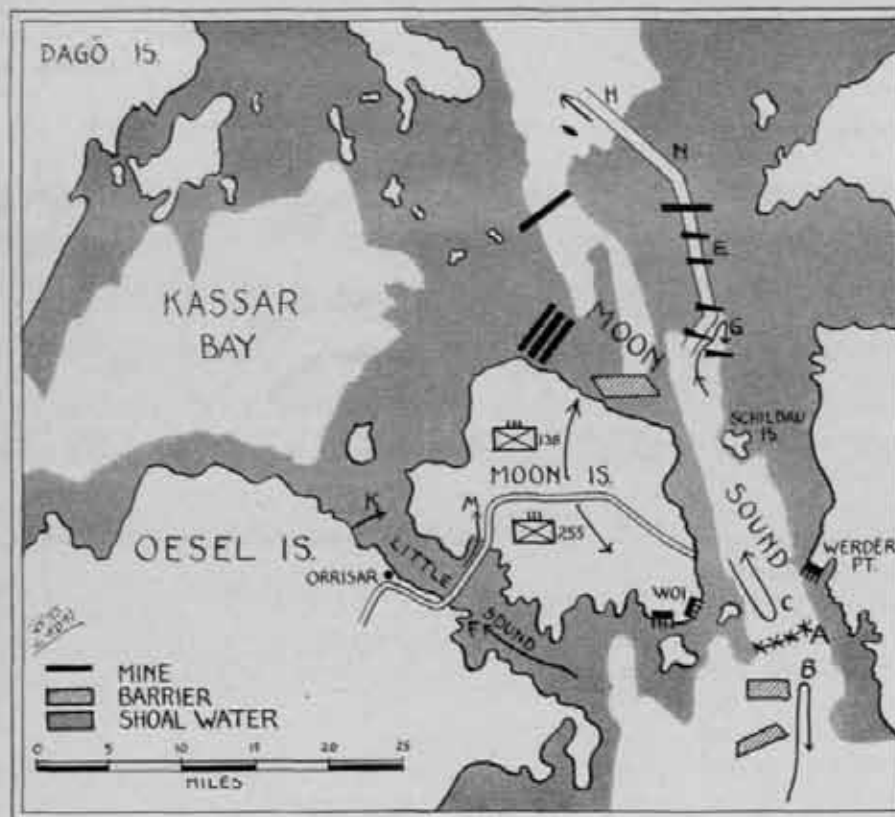

NAVAL OPERATIONS AND THE
INVASION OF MOON ISLAND
OCTOBER 17-19

- A Net and boom obstruction, covering anchorage
- B Bombardment of Russian fleet, 10:30 A. M., Oct. 17, by two German battleships.
- C Russian fleet turns and withdraws northward, 10:30 A. M., to escape (H).
- D Russian battleship "Slava" beached and blown up, but ineffective as obstacle to channel.
- E Four other hulks sunk in channel to block German pursuit.
- F Destroyers enter Little Sound to assist army, 3 P. M., Oct. 17.
- G Mine sweepers interrupt escape of Russian troops from Moon Island until driven back (Oct. 18) by superior Russian naval forces. (Cruisers and destroyers unable to reach this point until October 19 P. M.)
- H Escape of Russian fleet.
- K Ferriage of 138th Infantry from Oesel to Moon Island, P. M., October 17.
- M Invasion of Moon Island via causeway, A. M., October 18.
- N Dredged ship channel leading north to Baltic Sea and Gulf of Finland.

Map No. 11.

to establish an advanced naval base at Arensburg and to make the necessary preparations for landing the second echelon of the expeditionary force. The remainder of the squadron continued toward Moon Sound. En route the enemy's submarines struck twice: once, ineffectively, at the battleship *König*; and once, effectively, at the mine-sweeper *Indianola*.

At daybreak, October 17, this squadron, consisting of two battleships, two cruisers, and a flotilla of destroyers and mine-sweepers, arrived off the southern entrance of Moon Sound. Its mission was clear; it would invade Moon Sound and attack and destroy the Russian naval units there, thus cutting off the escape of the Moon Island garrison to the mainland.

The channel entrance was obstructed by mine fields, booms and nets (A). With the chart that had been taken from the foundering Russian destroyer in Kassar Bay as a guide, mine-sweeping operations were immediately undertaken. This was dangerous work, for the mine-sweepers were exposed to fire from the Russian seacoast batteries and from the Russian fleet. The Germans could do little to oppose this since they were outranged by the Russian fleet on the one hand and on the other could not close the range until a channel had been swept. A smoke screen laid by destroyers afforded some protection but by and large the mine-sweeping flotilla was forced to conduct its work under the deliberate and unopposed fire of the Russian guns.

By 10:00 A. M. a path, albeit a hazardous one, had been opened toward the inner sound and Admiral Behnke, taking advantage of this, at once moved in with his two

battleships (B) and at 18,000 yards opened fire on the Russian squadron. Within thirty minutes the Russian battleship *Slava* had received eight hits, one of which set her on fire, and two other enemy ships had sustained damage. Forthwith the Russians fled to the north (C) and out of Moon Sound.

In an effort to block the channel the Russians beached the blazing *Slava* north of Schildau Island but, finding this did not completely accomplish their purpose, they sank four more hulks (E) across the fairway a little further to the north.

Meanwhile the German pursuit had been delayed by the discovery of additional mine fields near the entrance to the Sound. While these were being swept Admiral Behnke turned his guns on the seacoast batteries at Woi (four 10-inch and four 6-inch guns) and at Werder Point (four 6-inch guns). The batteries at Woi were plainly visible from seaward, and therefore made excellent targets; the battery at Werder Point was better concealed, but the fleet was able to establish its position from the flashes of its guns. The Russians here soon called it a day, destroying and abandoning their guns. That afternoon a German landing party occupied Woi.

On the next day (October 18) the German mine-sweepers succeeded in picking their way through the partially-swept mine fields, booms and nets across the entrance, and reaching a position (G) from which they could interdict ferriage of troops between Moon Island and the mainland. But not long did these adventurous little ships enjoy their strategic position for within an hour or so an enemy squadron, striking suddenly out

of the north, drove the lightly-armed mine-sweepers south and out of Moon Sound.

The next afternoon two German cruisers, escorted by several destroyers, succeeded in penetrating the mine-infested waters as far as Schildau Island. By the 20th even a battleship had been maneuvered into the former Russian anchorage. Thus was German naval superiority definitely established in Moon Sound. The Russian fleet escaped, however, for so successfully had the channel been blocked that not even a tardy pursuit could be launched.

Meanwhile, Moon Island had fallen.

THE CAPTURE OF MOON ISLAND

As soon as the German forces at Orissar learned of the success of Admiral Behnke's attack, they prepared to advance to Moon Island. At 4:15 P.M., October 17, Commander von Rosenberg's flotilla of mine-sweepers, supported by artillery fire, began to ferry the 138th Infantry across Little Sound to the northwestern shore of Moon Island (K). This regiment was directed to operate against the rear of the Russian causeway garrison, drive them off, and thus open the causeway to the remainder of the 42d Division.

The 138th had no fight. As soon as one company reached a position on the flank and rear of the causeway guard, the Russians fled in dismay, leaving Moon Island open to invasion.

The next morning (October 18) the Germans took up the pursuit and by afternoon had penned up the Moon Island brigade in the northeastern part of the island. Russian transports were seen moving in to shore but these were driven off by the gun-fire of Admiral Behnke's light craft, which had run the gauntlet of partially-cleared mine fields to cut off the Russian retreat. Seeing their transports retiring to the north, the Moon Island forces realized that their last hope of escape had gone, and surrendered.

In addition to the original Moon Island brigade the German net closed on two battalions of the 470th Infantry, two battalions of the 471st Infantry, two battalions of the 1st Estonian Regiment and a "Death Battalion" composed of 600 volunteers. These units had all been rushed to Moon Island from the mainland on October 13 and 14 to reinforce the original garrison.

Although the original German plans looked only to the capture of Oesel and Moon Island, General von Hutier decided on October 14 to extend the occupation to Dagö Island. On the evening of October 18 one regiment of infantry, one cyclist battalion and three batteries of field artillery were assembled near Pamerrort and embarked the next morning on four steamers. The passage across the Strait and the landing were covered by a naval landing party that had occupied the captured Toffri battery since October 12 (see Part I).

The Russians offered no resistance and by October 21 the entire island was in German hands.

The lesser islands of Runo and Abro (in the Gulf of

Riga) were subsequently garrisoned by a few men who were ferried to these lonely outposts by naval planes. The novelty of the method justifies mention.

The German fleet returned to the North Sea and the 42d Division to the mainland. A small garrison, which included the cyclist brigade, remained in control of the islands until the Armistice.

* * *

In this study the authors have endeavored to present a compact and easily-followed account of a difficult operation. In pursuit of that object many minor adventures and misadventures were necessarily omitted. We use the term "minor" in the sense that taken individually these incidents were unimportant. If, however, they are considered collectively they become important indeed. The reader will therefore find various data emphasized in these closing paragraphs that did not appear in the narrative proper or did not receive adequate emphasis there.

Since a detailed analysis of the entire operation would require more space than *The Journal* can conveniently spare, the authors have confined their comment to three vital things:

- (1) The command set-up;
- (2) Signal communications; and
- (3) Embarkation, overseas transport and debarkation.

THE COMMAND SET-UP

In theory the command of the entire expedition fell to General von Hutier. But, in fact, his absence from the scene of operations resulted in a condition of coöperation between General von Kathen, who commanded the army contingent, and Admiral Schmidt, who commanded the naval component. Although the officers of higher rank appear to have worked together with considerable harmony, there was continual friction between the junior grades.

Liaison officers were exchanged by the two services in an attempt to establish a positive means of fostering close coöperation. That this device failed to produce the results expected was probably due to the low rank of the officers assigned to this duty, and their consequent lack of authority and prestige.

One of the most interesting features in the command establishment was the interpolation of an intermediate headquarters between General von Hutier and General von Esteroff, who commanded the 42d Division. As all troops employed in this operation were either integral parts of the 42d Division or were attached to it, the division commander would normally have become the expeditionary force commander. But the Germans are not disciples of the normal and to that very fact may be attributed the major part of their remarkable record in war. General von Esteroff landed and stayed with his division while General von Kathen, the expeditionary force commander, remained with his staff on the flagship *Moltke* in intimate contact with the naval leader. From this advantageous position von Kathen handled all ar-

rangements for naval cooperation, naval transportation of army troops, the initial landing, and the delivery of supplies to the beach. This left General von Esteroff free to fight his division without distraction. The success of this arrangement proved its worth.

SIGNAL COMMUNICATIONS

The communication difficulties inherent in any joint overseas expedition were heightened in this one. The speed with which the army penetrated Oesel Island prevented any extensive use of telephone lines. Therefore the heavy traffic of the army fell largely to the radio.

The navy encountered a similar situation. Circumstances forced the fleet to operate in small groups scattered throughout the archipelago instead of in the more usual mass of maneuver. Hence, they too were forced to rely to an unusual degree on the radio.

Then there were other loads with which the already overburdened radio had to contend: the army, the navy, and the air forces had to be tied in if they were to function as a team and, of course, communication with the commander in chief at Riga had to be constant.

It is significant that all these difficulties were foreseen. From the very inception of the operation the German High Command realized that all radio nets would have to be rigidly supervised if any degree of control was to be maintained. In furtherance of this idea the following set-up was adopted.

All radio communications centered in the flagship *Moltke* from which the following nets were operated:

- 1 Army headquarters at Riga.
- 1 The base at Libau.
- 4 Land stations to be established for the use of the army but operated by naval personnel.
- 20 Twenty battleships and cruisers.
- 17 Seventeen flotilla leaders.
- 6 Aircraft (for air-ground use).
 - 1 Aircraft mother-ship.
 - 1 Air base, Windau.
 - 1 Flagship of the transport fleet.

Total 52

From stations in italics, subsidiary nets were operated to lower echelons of the command involved. But even with this degree of decentralization, the *Moltke* still had to work 52 different stations.

On the morning of October 12 everything was quiet until the first troops started ashore and then, as if some prearranged signal had been given, every radio in the Baltic leapt to life. The army, the navy, the air force, hammered at each other and at the bewildered operators on the *Moltke*. Every net was hopelessly jammed.

The army complained bitterly that the naval radio operators ignored all messages originating at the four land stations—the bottle-neck for all army communications. General von Hutier was equally wrathful that his orders from Riga did not get through promptly and sometimes never got through at all. This unfortunate state of affairs continued throughout the entire period of

the operation. In fact, the army never fared any better until they built their own stations on Oesel Island at the end of the campaign and divorced themselves from the navy net.

Of the unmistakable lessons apparent in this experience three merit special emphasis:

(1) Communication difficulties in a joint operation should be provided for in the same manner that a wise man provides for his vacation expenses: determine them in detail and then multiply the result by two.

(2) Human nature being what it is, army troops should be prepared to erect and operate their own communication system at the earliest possible moment.

(3) Officers of both services, and of all grades, should be taught that the radio is reserved for urgent messages and that even then some other channel might be equally expeditious. Nor would a few lessons in brevity do any damage.

EMBARKATION, OVERSEAS TRANSPORT AND DEBARKATION

It will be remembered that the initial loading tables received from the Admiralty had to be discarded because they were based on maximum tonnage without regard to the priority of unloading troops, matériel, and supplies. The storm that blew up on September 27 and lasted until October 8 enabled the energetic von Hutier to prepare new tables that were based on fact rather than theory. But even then two errors were made that might well have had far-reaching effects on the expedition. First, all signal troops were embarked on one ship. Had that ship gone down the subsequent operation would have been launched under a telling handicap. Second, the various medical units were given a ridiculously low priority. Not until forty-eight hours after the landing had gotten under way did the first medical troops set foot on shore. Had the landings been contested, some German staff officer would have had many a needlessly wasted life on his conscience. Such small and easily overlooked details as these may well determine the ultimate issue in that most delicate of all operations—the joint army-navy expedition.

General von Tschischwitz probably had that very thought in mind when he offered the following two suggestions for organizing beaches in an initial landing:

(1) Large signs, bearing the identifying number of the transport in figures of such size as to be seen clearly from the ship itself, should be sent ashore in the first boats and immediately set up. These will serve as guides to succeeding tows of small boats as they are nearing the shore and thus eliminate a great deal of confusion and running back and forth.

(2) A naval liaison officer with several runners should accompany the first boat-load of any army unit. This party should be charged with the task of guiding troops from succeeding boats to the fighting line, which will usually be some distance inland. Unless some such positive guide method is established the larger tactical units

will seldom if ever be assembled. Instead there will be a wild collection of sections and platoons utterly lacking in tactical unity and incapable of determined offensive action.

One serious problem not satisfactorily solved in an otherwise successful landing was the task of getting the field artillery ashore. Despite the specially constructed barges referred to in Part I, this part of the plan worked poorly. The Germans worked desperately with their guns but in spite of all they could do a serious delay resulted. And the repercussions of this delay in landing the artillery were apparent throughout the entire operation. High surf and field artillery on barges present a pretty problem for soldier and sailor alike. It is one that should be definitely solved and proved before a landing operation is attempted. For not often will an invader be confronted by an enemy who can be handled without recourse to the long arm of the artillery.

One further fact should be noted. The Germans' preference for transports of moderate size was marked. In these mine-infested waters the smaller transports minimized the risk. Not too many eggs in one basket is a motto that can well be applied to other things beside finances.

* * *

And so we come to the matter of conclusions. Much could be said on this score but we elect to say little. We content ourselves with listing the four major items that contributed most to this successful operation and four more that militated against it. Under the former head we list:

(1) The Russian lack of vigilance, leadership and fighting spirit and their failure to employ their naval forces, especially their submarines, more aggressively.

(2) The excellence of the German plans; particularly the emphasis placed upon surprise.

(3) The degree of coöperation attained between the German army and navy.

(4) The rapidity of German maneuver.

Under the second head we find the following major weaknesses:

(1) Failure of the planned unity of command; the absence of General von Hutier at Riga brought about the very condition of enforced "coöperation" between army and navy which it had been intended to avoid.

(2) Failure of army-navy communication.

(3) The inability of either service to understand and appreciate the problems of the other plus a mutual distrust.

(4) Conflicts of authority between junior officers of the army and navy during the embarkation.

* * *

Much has been said of the "Russian enigma" in this operation; but was there an enigma? The Russian soldier was war weary. For three years he had been poorly equipped, poorly fed and poorly led. He had been terribly defeated every time he had stood against the great German military machine. His losses still stagger the imagination. The Provisional Government had blindly struck away his last sustaining prop—discipline—by its General Order No. 1. Behind him a new and strange order of things was coming into existence. Under the bludgeonings of circumstance the Russian soldier of 1914 had been beaten to his knees; by the fall of 1917 there was little fight left in him, and small wonder.

What actually happened in the Russian lines during the invasion and capture of the Baltic Islands will probably never be known, for no Russian accounts have ever been written. We do know that leadership was virtually non-existent and mutiny rampant. Why seek further for an answer?⁴

⁴For the major part of the factual data in this study the authors are indebted to that invaluable source book, *Armee und Marine bei der Eroberung der Baltischen Inseln*, by General von Tschischwitz, who was Chief of Staff of the German Expeditionary Force.



THERE IS ONE CHOICE *we cannot make, we are incapable of making: we will not choose the plan of submission and suffer the most sacred rights of our nation and our people to be ignored or violated.*—WOODROW WILSON.

Warfare in the 18th Century—IV

BY LIEUTENANT COLONEL J. M. SCAMMELL
Infantry, N.G.U.S.

THE STAFF AND THE DIVISION

THE seeds of Napoleonic warfare were planted long before Napoleon. They were planted in the soil of society itself. They were warmed by the sun of science and watered by the sweat of diligent military students. They were fertilized by the brains of the dead. The divisional system had begun to put down roots before the Corsican was born. The general staff had germinated long before Napoleon was yet in his mother's womb. The new musket and the Gribeauval gun were but tools with which the soil was tilled. They made it possible to cultivate ideas already old so that visions might flower into reality and bear the fruits of victory.

The scientific, commercial, industrial, and cultural developments in Europe, especially during the latter part of the 18th Century, made it possible to raise and maintain larger armies and to endow them with an increasingly greater number of guns. The problem arose how best to maneuver these great armies. Weapons were improved as regards range, accuracy, and rapidity of fire. Improvements in road construction and in map making promised developments as regards mobility. Intelligent and industrious officers began to grapple with the problems, how to maneuver large masses of men in the field, and how to take advantage of the characteristics of the new arms. One device designed to meet the problem was the creation of a corps of skilled assistants for generals.¹ A second was the practice of subdividing armies into smaller groups, each a self-sustaining unit capable of independent action. With the fusion of these two developments—the staff and the articulation of armies—the divisional system bloomed.

From 1735 to the beginning of the French Revolution

¹Guibert stressed the need for such assistants, saying, "Today a Xanthippus or a Camillus would not be equal to one half of the knowledge made necessary by modern military science. The commander of today is drowned in details, blinded by the complexity and confused by the numbers (100,000 men) of a modern army whose movements he must coordinate and whose subsistence he must assure. He must, in addition, overcome obstacles imposed by our imperfect institutions. An hundred thousand enemies are raised up against us within our own ranks. He must frame a plan of campaign embracing several alternatives. He must combine these alternatives according to the multiplicity of the objectives imposed upon him. So many distractions form a burden beyond his powers. His mind becomes fatigued and is overwhelmed by them; or, at best, he survives only with difficulty and is forced into the rôle of a second-rate or even a third-rate general."

A century and a half later we find Foch in his *Principes de la Guerre* (p. 19) citing von der Goltz to the same effect: "Today the commander-in-chief can no longer perform all the functions of command himself. Even a military genius finds need of assistants, trained in technique and prepared to take initiative. How much more may a general who is not to be reckoned among the stars of the first magnitude have need of help to extend his powers. The exercise of command in an army is too complex for a single man."

The French Revolution, by cutting the army adrift from traditional routine, released new sources of power.

there had been consistent efforts to create a corps of capable assistants to simplify the task of army commanders. During the same period the army had been evolving gradually into a group of semi-independent subdivisions. The foundations of these developments had been laid by Bourcet, who for the first time worked out the methods by which the action of independent columns could be coordinated. In calculating marches Bourcet took into account such factors as information of the enemy and his probable intentions, liaison between the elements of the army, the military obstacles to be foreseen and overcome, and the length of time the enemy might be expected to slow up the march by taking up delaying positions. Bourcet taught a war of patient, detailed calculations, of painstaking combinations, and of energetic execution.

The practice of subdividing an army into self-reliant units developed only gradually. Luxembourg detached groups of all arms for particular purposes, such as to seize river crossings, and to form bridgeheads. Villars and Berwick extended this practice. The latter defended the line of the Alps by creating independent groups in the Maurienne, in the region of Briançon, and in the vicinity of Tourneaux. Each group was so located that it could cooperate in a common scheme of defense. Saxe used divisions, albeit intermittently. He joined together two brigades of infantry with one of artillery for the duration of a campaign. Sometimes he combined two infantry divisions with one cavalry division to make an army corps. In a truly Napoleonic maneuver, by a concentric march of his divisions, he threw the enemy back into the Meuse River.

In 1759 Marshal de Broglie definitely adopted the divisional system. He employed the divisions in such a way as to threaten or to defend a wider front than could have been possible with a massed and unarticulated army. Toward the end of 1761 de Broglie divided his army into seven or eight corps, each encamped many leagues from the other. Thus it was easier to subsist his troops, and possible to cover a wide front. When Ferdinand of Brunswick tried to surprise him, de Broglie pushed forward one of his divisions to delay the advance of the enemy while he called up the others. Ferdinand, his army being made up of contingents of all arms from Prussia, Holland, Brunswick, Great Britain, and Hesse, had in effect a number of divisions; but he did not use them as such. De Broglie, on the other hand, used his divisions to feel out the enemy, to delay or impair his movements, to take up the shock while the other di-

visions came up to be used in a decisive maneuver. By using these divisions on a wide front de Broglie achieved a remarkable flexibility. Without using special detachments for these purposes, he was able to cover his own flanks and to menace those of the enemy.

During the latter part of the 18th Century the idea of the divisional system was abroad. It is probably no more than a curious coincidence that in 1763-1769 a Jesuit missionary brought from China extracts from the works of the old Chinese masters of the art of war. Père Amiot published a translation, which an anonymous French officer analyzed and commented on in 1774. One of the maxims of Wu was, "So distribute your army that all the corps of which it is composed may mutually support one another."

When General Washington took command of the Colonial troops besieging Boston (July 5, 1775) one of the first things he did was to issue an order organizing the army into brigades and divisions (July 22, 1775). General Washington was accompanied to Cambridge by Charles Lee, a former officer in the British service who had seen much fighting in European wars. By 1780 the idea of an army as a group of divisions spread out on a wide front, often separated from one another by several days' march, but so grouped as to be readily united for battle, was the common conception. In 1781 in America, Vioménil marched his divisions one day's march apart. By a royal ordinance the King of France in 1788 put the divisional system on a territorial basis and made it permanent in peace as in war.

The divisional system was now permanently adopted. What was needed to control it was a general staff.

The "dilatatory" generals of the early 18th Century and their predecessors were not always stupid. They were not always ignorant. They were not always incompetent. They were seldom timid. But they had been handicapped by real difficulties. States were poor. Armies were small. They were recruited from the dregs of society. Their powers were circumscribed by the limitations of the era. Their weapons and other furniture were such that soldiers were of use in battle only after long and thorough disciplinary training. Even without battles the rate of wastage was high. Battles once joined were devastating. The opposing armies stood at point-blank range and blasted one another into eternity. Casualties of almost any description usually became permanent losses. It was for such reasons that a good general refused to engage unless he felt assured of victory; and the conditions of war were such that he could decline battle at will. Roads were few and often worse than none at all. Artillery and trains were long, cumbersome, and slow. Maps were rare, seldom to accurate scale, and almost worthless. Without good maps it was difficult to know the character of the terrain.² It was no simple mat-

ter, under these conditions, to plan maneuvers or to calculate marches.

Commanders, feeling the need for a knowledge of the terrain, at first used engineer officers for topographical reconnaissance, because they were trained in making maps and had skill in appreciating the military features of the terrain.³ Hence there came to be an increasing demand for them. "Louis XIV at the time of his greatest glory, with 400,000 regular troops, had only 55 engineer officers." By 1789 the number had increased sevenfold, to 376.

Responsibility for reconnaissance and the planning of operations rested with the *Maréchal général des logis*. Bourcet in a memorandum to the Ministry of War proposed that a staff corps be created to make reconnaissances, to produce maps, and to draw up war plans. In 1766 Bourcet was placed at the head of a specially selected corps of officers who were to be trained in topographical and cartographical reconnaissance. They were to make staff tours of the frontiers, draw up map problems, and perform other general staff duties. Four years later a general staff corps was formed; but the following year (1771) saw it discontinued as a measure of economy. In 1777 the Minister of War, St. Germain, suppressed it entirely. Six years later, in 1783, Louis XVI reopened the staff college in honor of the young French veterans of the War for American Independence, and a general staff corps was once again formed.

Thus at the beginning of the French Revolution, France had a trained staff. Many trained staff officers, being royalists, emigrated; but a nucleus remained, so that it was possible to make use of the divisional system.

Bourcet had taught the use of independent little corps scattered over a wide front for mountain warfare, and had devised methods for coördinating their action. In that type of warfare, mountain barriers permitted a great degree of dispersion. The new weapons with their holding power, and the greater mobility of armies made it possible to adapt Bourcet's conceptions to open warfare. These ideas were incorporated in books or in the minds of officers who served in the wars of the French Revolution.

The new ideas of warfare were not the fruits of the French Revolution, which actually interrupted a long series of developments. Thoughtful officers had long before sought to make use of conscription, to employ patriotic fervor, to increase the mobility of armies, and to shake off the fetters of supply trains and dépôts. The French Revolution, by cutting the army adrift from traditional routine and from established interests, released new sources of power; to that extent it more than compensated for the emigration of trained officers.

With the coming of the divisional system there could be no more "inattackable" positions. No longer were battles considered lost before they were begun because

²According to Jomini (*Tableau analytique des principales combinaisons de la guerre*, 41): "All the army of Napoleon and that great captain himself regarded the interior of Bohemia as a mountainous country; whereas there hardly exists in Europe a more level plain." This was as late as 1813.

³This practice was followed in the United States Army as late as the war with Mexico. Cf. Douglas Freeman, *R. E. Lee: A Biography*, I, Chaps. xv, xvi, and xvii.

the enemy was superior in numbers. With armies mobile, flexible, able to expand or contract at will, capable of an infinite variety of maneuvers, with a wide radius of action, surprise and movement became more important than numbers and position. The golden age of maneuver was at hand.

Even if isolated, a division of all arms could defend itself for many hours. It could take up a defensive position and hold off the enemy until its fellows could arrive and deploy according to a definite scheme of maneuver. Under cover of a holding attack by relatively feeble units, a commander could maneuver on the battlefield, selecting his plan of action based upon a knowledge of the enemy's dispositions. Colin quotes Bosroger as saying that "An able general brings on an engagement from afar by a series of operations which force the enemy to conform to his will and, so to speak, compel him to give battle on a field that has been made ready for him in advance."

The tacticians of the 18th Century did not conceive of an army as being concentrated only when its elements were in close physical contact. They did not confuse a coordinated attack with a simultaneous attack. They were not mere mechanics, but artists who understood their craft. Technical knowledge and understanding may be as far apart as the poles. Some of our modern technicians, taught to despise their 18th Century predecessors, are like the regimental commander who insisted that all the trombones in his band slide back and forth in unison. The tacticians of the 18th Century whose methods gave Napoleon success, were content that every unit should play its part—and not a standardized part—in the orchestra of battle.

Napoleon has been worshipped as the god of war. There was no god but Napoleon, and Clausewitz was his prophet. Clausewitz, like another Moses, went up a little Sinai and received an imitation revelation from his godling. With a jigger of thunder and a dash of lightning he received it out of a very thick cloud, to which he restored it in book form. The works of Clausewitz held all of the authority and all the mystification of a pronouncement of the Delphic Oracle. They seem to have received reverence in direct ratio to their incomprehensibility. They were systematically misapprehended by almost all soldiers who read them, and by all who did not.

Against this mystic cult, in 1913, a prophet lifted up his voice in the intellectual wilderness. This prophet was Colin, whose study of the education of Napoleon has been drawn on for these articles. He published his

prophecies in a book called *Les grandes batailles de l'histoire, de l'antiquité à 1913*. In his chapter on the battle of the future Colin stated:

Since the Napoleonic Wars strategical operations have culminated in the battle which has become their natural object and crowning achievement. In a future Franco-German war the strategy and the battle will be so closely fused together that it will be almost impossible to analyse them separately. Simple minds may be deceived by this superficial appearance and will attempt to reduce war in the future to the problem of transporting troops by the greatest possible number of railways and to rush them straightway into action after they have detrained.

Colin apparently believed that this blunder would be too stupid to be made by a trained general staff; for he continued:

We must . . . expect to see the armies of the future, not deployed in a line of army corps from Basle to Longwy or even as far as the Meuse in Belgium, the very moment they detrain; but formed into groups of unequal strength and with unequal frontages for the purpose of maneuvering before being engaged.

But in view of the prevailing tendencies in the French Army, Colin had his misgivings. He issued a strong warning:

An army led with neither art nor prudence, concentrated from the first close to the frontier, runs a triple risk: that of going into action before it receives its full complement of reservists; that of being too feeble to gain the victory at the desired point while being needlessly strong at other points where the enemy could be held up with weak forces; and, finally, the risk of beginning with a half victory, perhaps encouraged by the enemy for his own purposes, only to end in a complete disaster. These dangers may disappear only if the enemy makes the same mistakes, and if the two armies confront one another in formations equally linear and homogeneous with no plan of maneuver and no possibility of it.

Here, in words written the year before 1914, lies the explanation of the Battles of the Frontiers, of the Marne, and of the subsequent development of trench warfare.

The soldiers of our time can ill afford to scoff at those of the 18th Century. That was an age of great military thinkers—Lloyd, Bourcet, Guibert and du Teil. It was also an age of great captains. It produced a Frederick the Great, nursed a Washington, gave suck to Napoleon, and bred his conqueror. Where are their like today?

As those who travel over an unknown road, they took heed not only of the pathway at their feet, but glanced at the back trail and at landmarks toward the front. They saw the scene around them; they looked back on the soldiers of old times and took counsel with them; they fixed their prophetic gaze on the far horizon of the future. They saw clearly, interpreted intelligently, and built solidly the foundation of a sound theory of war.



Antiaircraft Machine Gun Fire Control—1936

By MAJOR E. T. CONWAY, C.A.C.

Results of tests of C.A.B. Project 1046

PROJECT number 1046, entitled Antiaircraft Machine Gun Fire Control, Methods and Equipment, 1936, was assigned to the Coast Artillery Board by the Chief of Coast Artillery early in 1935.

The matériel and troops were assembled at Fort Story in February, 1936, and for two months a series of firings and investigations, divided into many phases, was conducted primarily with a view to testing the new equipment.

CENTRAL CONTROL

The central control equipment, using a flexible shaft for transmitting data to the front sights on the four machine guns of a platoon, was constructed by the Ordnance Department along the general lines of the equipment built by the Coast Artillery Board and reported upon in Project number 1012 (1934). This equipment was thoroughly tested at Fort Story; with the exception of a few mechanical faults it functioned satisfactorily.

This central control equipment heads up in two control boxes at the platoon commander's CP. It is capable of operation either with central tracer control or with central control using computed data and tracer adjustment. There is nothing in the system to interfere with reverting instantly to individual control.

The control boxes (one for lateral and one for vertical movement of the gun sights) contain three dials, two input and one output. One input represents the estimated or computed deflections obtained from the range section and the other input represents arbitrary spots obtained from tracer observation. The output represents a matching of the two input dials by one large crank which rotates the four flexible shafts connected to the guns. If central tracer control is to be used the operator mans the large crank and ignores the dials except to note the amount of opening lead which has been set. When central control with computed data and tracer adjustment is used, all parts of the instrument are brought into play.

The guns used during the tests were emplaced in a pseudo-diamond formation with distances such that the longest flexible shafts were 125 feet.

Tube and ring sights were tested with the central control equipment.

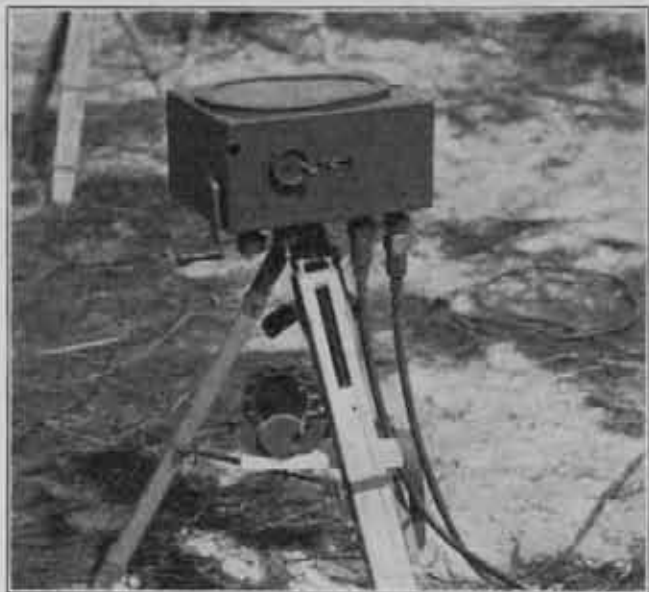

FIGURE 1

A central control box hooked up to two guns. The hand transmitter, shown between the tripod legs, is used for setting in computed deflection. The large crank is used to send the computed data to the gun sights. The small knob is used to set in adjustment corrections.

The open ring sight enables quicker target location but with the tube sight it is easier to maintain true alignment; the latter is not very good at night.

A series of computing sights for individual gun control

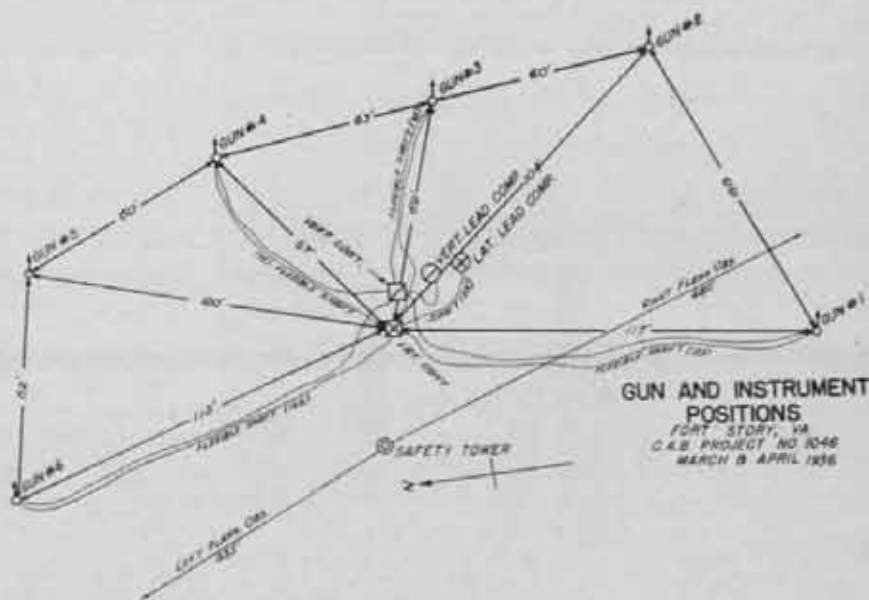

FIGURE 2

Layout at Fort Story. Gun positions 1, 3, 4, 6 were used with central control equipment. Gun positions 2, 3, 4, and 5 were used for computing sight tests.



FIGURE 3

A binocular on ball type flexible mount for use in tracer fire adjustment.

was given a thorough test. Each sight was made for a specific crossing course; these represent a further development of the sights designed by Major C. S. Harris. Results were good within definite limitations but that development has been tabled for the time being.

Aids to antiaircraft machine gun fire control used during these tests were:

Lead computers, designed and built by Major G. B. Welch, O.D. and Captain L. L. Davis, C.A.C.

Telephones over which gunners can hear during the firing.

Binoculars on a ball type mounting, built by Master Sergeant Horstmann.

Goggles for gunners.

Binoculars with colored lenses for flank spotters.



FIGURE 4

One-meter stereoscope used by the platoon commander or his observer, for tracer observation. Telephone is provided for use if spotting is called for by the central control adjuster.

A stereoscope (not a range finder) for tracer observation.

A method of flank spotting based on the principles laid down by Captain R. B. Pape in his paper on "Tangential Observation."

The Coast Artillery Board has recommended the adoption of each of the above listed aids. The lenses for binoculars, the goggles for gunners, the stereoscope, and the binocular mounts are past the first stage, and have been found to be practicable. The next step is the service test of an approved model furnished by the development agency, either Ordnance Department or Signal Corps. Flank spotting is dependent on a practical means of data transmission, either the telephones mentioned above or some other device not yet formulated. The lead computers are the subject of much discussion as to their possible use for gun fire control. They will be discussed later.

As visualized at present, there are three forms of fire control applicable to machine guns; they are:

Individual tracer control,

Central tracer control, and

Central control with computed leads.

It is believed that the third system (admittedly the most involved) will be applicable in a certain percentage of cases, especially at long ranges. However, continued effort should be made to perfect the other two systems; the first (individual tracer control) probably will be used against the majority of targets. One of the stumbling blocks to improvement in tracer control is the fact that only on rare occasions has a gunner been able to see the tracers actually passing through the target throughout the entire course. Studying the appearance of the tracers on a few good courses, greatly helps the average gunner in directing his fire. Therefore training on precise methods of fire control, however involved, is believed to be excellent training for less precise methods.

CENTRAL CONTROL PROCEDURE

A picture of the complete fire control system using central control with computed data and tracer adjustment can best be shown by a description of a typical firing problem.

When the target appeared the executive officer gave a whistle signal—the platoon sergeant, using the telephone called "target" to the four gunners, giving its general direction. In an average time of two seconds all concerned were tracking. The range officer estimated the speed of the target and the range to the midpoint of the course; the operator of the lead computer oriented his instrument so that it remained parallel to the course of the target and the deflection readers were instructed by the range officer which curve to follow. Data was called off, set by the deflection transmitters, matched at the central control boxes and, if the target was within range, firing was begun by ordering "commence firing" through the telephone. Fire was opened in an average time of about six

seconds using the initial data as estimated by the range officer. Measured data was available a few seconds later and if necessary, initial estimates were corrected. As soon as commence firing had been ordered a flank spotter equipped with colored lens binoculars (if he faced the sun) was cut into the telephone line; he continuously announced the appearance of the tracer stream. This spotter was located on the flank toward which the target was flying. His reports were heard by the adjusting officers whose stations are near the central control boxes. With their right hand on the adjusting handwheel of the control box and their left hand moving the control handle of the binocular mount, the adjusting officers continuously applied corrections to the computed leads set on the sights. The platoon commander, or his stereoscopic observer, studied the results through a one-meter stereoscope. He was prepared to take over the spotting whenever the flank spotter failed to see the tracers or for any other reason his station could not function efficiently.

The points of special interest in the procedure not so far discussed, are the lead computers and tracer adjustment.

LEADS AND THE LEAD COMPUTER

In the development of the computing sights, the Ordnance Department computed the lateral and vertical leads for certain typical target courses. Attention is invited to Special Text No. 26, 1936 Edition. In this will be found a description of the method of computation and the results (Fig. 5).

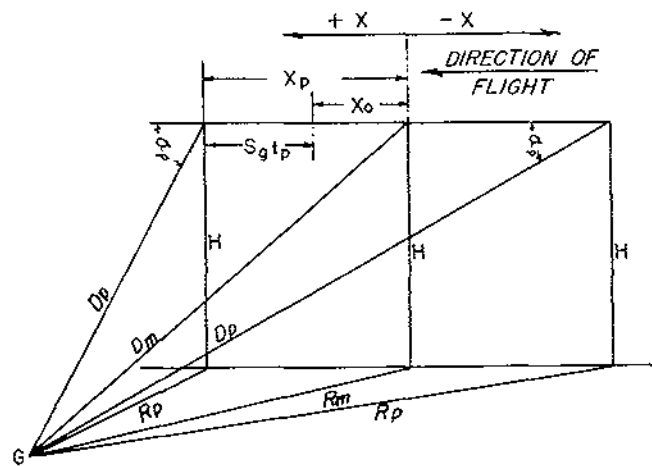

FIGURE 5

a. Glossary of Symbols:

- D_m = minimum slant range.
- R_m = minimum horizontal range.
- X = distance traversed by plane, measured from point corresponding to minimum slant range, and positive in the direction of flight.
- α = Angle of Approach: angle in *inclined* plane between line of flight and line of sight. Note that this angle is greater than $\pi/2$ (90°) when X is plus.
- Δ = finite difference.

b. Equations:

- (1) $D_m^2 = R_m^2 + H^2$
- (2) $D_p = (D_m^2 + X^2)^{1/2}$
From Firing Table, find t_p and ϕ_s corresponding to each D_p . Then compute ϵ_p and α_p in radians from
- (3) $\sin \epsilon_p = H/D_p$ and
- (4) $\cos \alpha_p = -X_p/D_p$ ($\cos 180^\circ - A$) = $-\cos A$)
Now determine present position data from
- (5) $X_o = X_p - S_g t_p$
- (6) $D_o = (D_m^2 + X_o^2)^{1/2}$
- (7) $\sin \epsilon_o = H/D_o$
- (8) $\cos \alpha_o = -X_o/D_o$
Convert ϕ_s to radians and compute
- (9) $\Delta \epsilon = \epsilon_p - \epsilon_o$
- (10) $\sigma_L = \phi_s + \Delta \epsilon$
- (11) $\delta_L = \alpha_p - \alpha_o$

The results are angular values in radians. This is convenient for general work, *i.e.*, for example, computing curves for a computing sight having a sight base of given length, as it is necessary merely to multiply angular values in radians by the sight base in inches to get points on the curve in inches from the center of the sight. To get leads in yards, multiply angular units in radians by slant range in yards. To get leads in mils, multiply angular units in radians by slant range in *thousands* of yards.

The method of lead computation used in Project 1046 considers the principal vertical deflection to be the difference between the present and future angular height; the lateral lead to be the difference between the present and future angle of approach (measured in the slant plane containing the course of the target and the gun).

Like most approximate methods, this varies slightly from the strictly correct method of determining the leads to be set on the tangent type of sight which moves with the gun barrel and is in a different slant plane from that containing the course of the target. A graphical study of the slant planes* involved in this particular sight and gun movement is given in Figure 6.

*The formulæ for computation of leads using Major Welch's slant planes were determined by Major J. T. Campbell, C.A.C., to be as follows:

Lateral Deflection = $\tan^{-1} \frac{(X_o - X_p) R_m}{(X_o X_p + R_m^2) \cos(\epsilon_p + \phi_s) + H R_p \sin(\epsilon_p + \phi_s)}$

Vertical Deflection = $(\mu + \epsilon_p + \phi_s) - 90^\circ$

Where $\mu = \tan^{-1} \frac{X X_p + R_m^2}{H R_p}$

A comparison of the results of the two methods will be of interest:

Course	X_p	Spec. Text No. 26		W-C Method	
		δ_L	σ_L	δ_L	σ_L
B	- 800	54.2	27.9	53.3	27.4
	+ 800	59.0	7.5	58.0	7.0
H	- 1200	50.5	52.7	38.4	52.4
	+ 1200	60.8	- 19.9	46.1	- 20.4
N	- 400	147.5	32.5	146.8	29.8
	+ 400	165.8	0.	164.9	- 3.9

The values in S.T. No. 26 are close to those computed by the more precise method when the target is near the normal of the course.

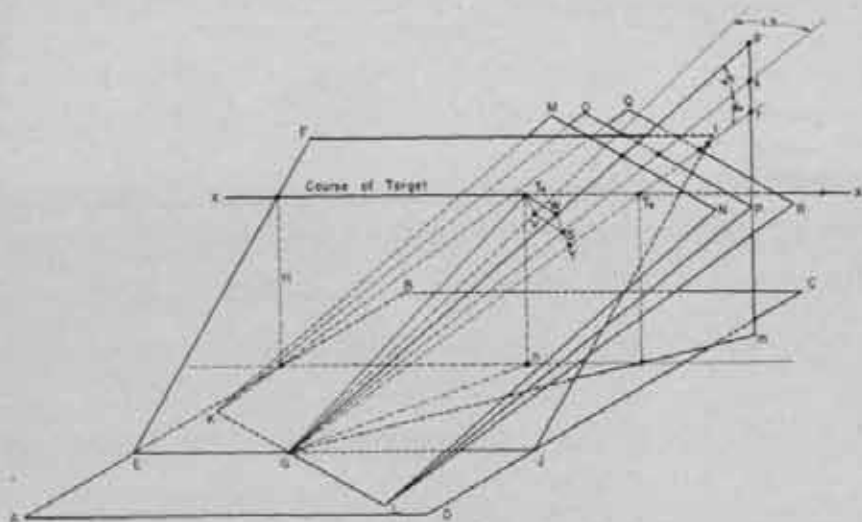

FIGURE 6

The search for a method of using the information given in the lead tables for central data computation gave birth to the present lead computer. Major Welch designed an instrument based on a new application of the angle of approach principle; this soon became known as the Welch Rabbit.

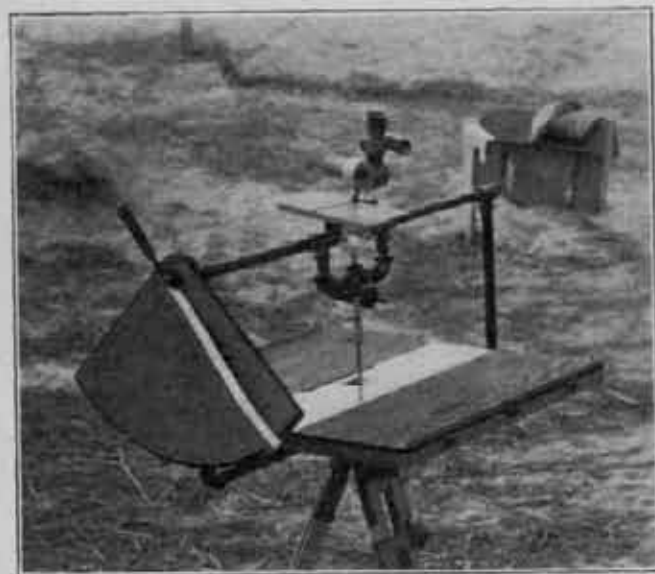

FIGURE 7

LATERAL LEAD COMPUTER (WELCH RABBIT)

The end chart is used for the determination of R_w . The plate just below the elbow sight is used for measurement of ground speed.

The purpose of this computer is to orient a chart containing lead curves and to provide a pointer to indicate on the appropriate curve the point which represents the position of the target at the instant of observation.

The lead computer was designed to fulfill these two functions. It was desirable to have the chart and the pointer rotate in a horizontal plane; to accomplish this, a universal joint permits the sighting instrument to rotate in the slant plane containing the course of the target and at the same time to rotate the chart as desired.

A rectangular metal frame was mounted on a type "A" tripod. A table was fixed to the lower horizontal bar of the metal frame. In the center of the upper horizontal bar an elbow sight was mounted on a universal joint. A vertical shaft (projecting downward) was fixed to the universal joint. Beneath this the lead charts were attached to the table.

The feature of the lead computer which makes it different from any device so far used, is that by keeping the target traveling along the horizontal wire in the sight, the metal frame is maintained parallel to the course of the target. In operation, the observer makes a rapid orientation of the frame, glances

over the open sights at the target and then looking through the elbow sight he sets and keeps the instrument exactly parallel to the line of flight, regardless of any change in the course of the target. A change of direction is immediately made evident by the tendency of the target to move up or down the vertical wire.

The elbow sight rotates in the slant plane which contains the course of the target and the gun position. The complement of the angle of approach of the target is continuously set up. The angular height of the slant plane containing the course of the target is available by the measurement of the vertical rotation of the yoke holding the elbow sight. The horizontal pivot of this yoke is coincident with the center of the universal joint. A pointer mounted on the vertical shaft suspended below the sight and in the vertical plane containing the line of sight, points at the horizontal projection of the target's position.

Captain Davis prepared the machine-gun charts used with the lead computers. He plotted the leads for each point on each of the computed courses along the horizontal projection of the line of sight. For convenience two lead computers, one each for lateral and vertical leads, were used. Curves of lead variations on each course were drawn and the charts containing these lead curves were fixed to the lower ends of the vertical shafts. The indicated lead was read from a fixed scale as the selected curve passed beneath it.

The selection of the proper curve depended on the determination of S_e , R_w and H of the course of the target. An estimated altitude was used at Fort Story and the R_w was found by combining therewith the ϵ of the slant plane obtained from the end chart on the lead computer. Ground speed was measured on a grid chart below the elbow sight by timing the passage of a pointer along a selected line representing the course of the target.

The vertical lead for courses coming over the gun position were obtained from an end chart on one of the lead computers. For this type of course the observer set the

frame perpendicular to the course of the target and tracked the plane in angular height.

The development of the technique of using the lead computer on maneuvering courses, particularly on the "crossing to coming" course has led to many improvements in the instrument. This is being covered in detail in a separate project in connection with the report of the test of this instrument with both antiaircraft guns and antiaircraft machine guns.

TRACER ADJUSTMENT

Tracer observation and adjustment is easy to visualize but as all machine gunners know, it is difficult to accomplish. During the tests for Project 1046, one objective was to find out how this could be done. The five principal means to this end were:

- a. Lead computers which kept the deviations small and fairly regular.
- b. Telephones so that full and complete information could be furnished from several viewpoints.
- c. Flank observation.
- d. Stereoscopic observation.
- e. And most important: the adjusting officers were equipped with binoculars with which they could follow the target, and view the tracers to considerable depth.

The lead computer is essential. Central tracer control tests by the Coast Artillery Board and by the 64th Coast Artillery have indicated that without computed data, the other aids (telephone, flank spotters and glasses) cannot be used effectively on all courses. The aids so far tested with central tracer control, have been quite inferior to those used at Fort Story; however they will be subjected to extended service test.

Flank spotting proved most valuable and interesting. When observing from a point where the line of sight from the flank to the target is tangent to the curve made by the tracers it is a fact that an adjusted stream will come just up to the target and then fall away. If the stream is behind, tracers never reach the target. If the stream is ahead, tracers cross the line of sight twice. While it is impossible to place observers in a position to maintain this point of true tangency, the method used at Fort Story insured that they were on this point at least once on crossing courses. To accomplish this it was necessary to have observers on each flank. For incoming courses, the safety officer's tower behind the firing line was satisfactory: the stereoscope was brought

into play, partly for convenience and partly as a test of that form of spotting.

Viewed from the central control position the slant plane of the tracers is clearly outlined. Unaided eye observation is satisfactory for the determination of "highs" and "lows." The trick then is to adjust the laterals.

It was found that the flank observer could spot efficiently only in one sense, either "ahead or behind" or "high or low." The latter sensing is usually the most evident, hence spotters were instructed to announce "high," "low" or "OK." The adjusting officers viewing the slant plane of the tracers from quite a different angle interpreted the reports of the flank spotter as follows:

- a. If tracers look low, and spotter reports low, they are *low*.
- b. If tracers look OK for elevation, and the spotter reports low, they are *behind*.
- c. If tracers look OK for elevation and the spotter reports high, they are *ahead*.
- d. If tracers look low, and spotter reports OK, they are *low and ahead*.
- e. If tracers look high, and spotter reports OK, they are *high and behind*.

On several occasions, it was noted by the adjusting officers that the spotters were reporting the tracers exactly as the officer saw them. There should not be exact agreement between the two viewpoints unless the tracers are

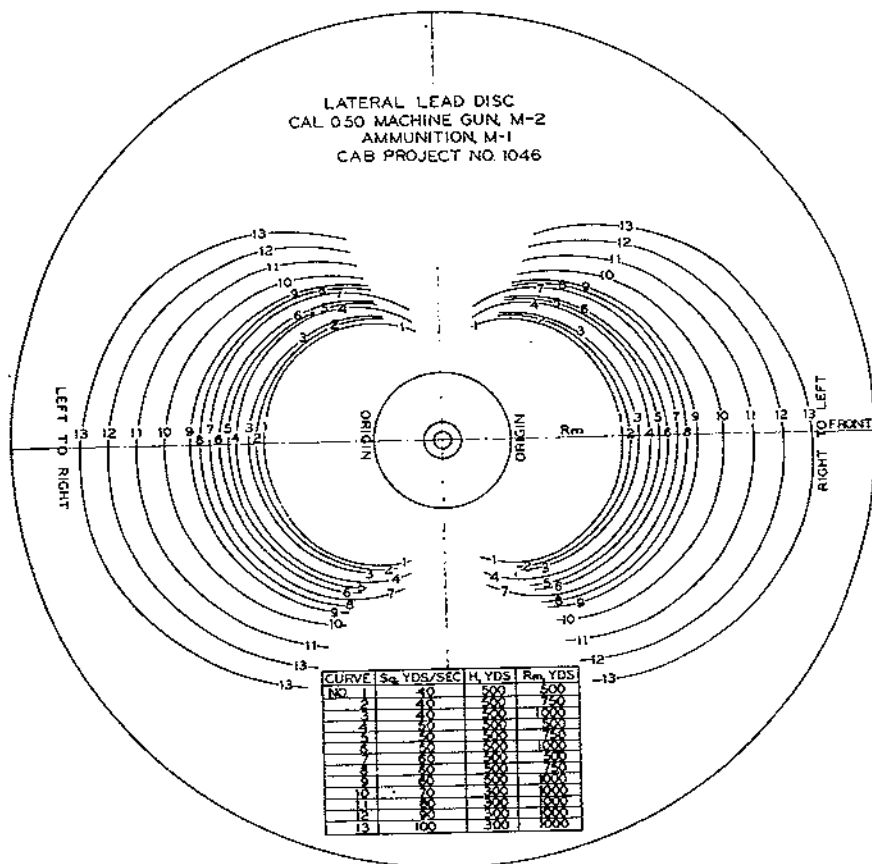

FIGURE 8

Curves of lateral lead variation computed for the indicated crossing courses and used on the antiaircraft machine gun lead computer.

actually passing through the target. It was quite obvious that this was not the case, hence the spotters were moved further to the flank; it is better to have them too far than too close. It was found that about 150 yards is satisfactory for caliber .30 and 300 yards for caliber .50.

SEMI-DARKNESS AND SPEED TESTS

Several special tests were made at Fort Story in an attempt to clear up doubtful points about the applicability of the equipment to high-speed maneuvering targets. In addition, a series of special tests were made to determine what type of fire control is applicable during periods of twilight and darkness. Firing without illumination was conducted on several courses.

The results of these tests may be summarized as follows:

After darkness, targets are not visible at any range. The glow from the exhaust vapors of older type planes has been considerably reduced.

Immediately prior to complete darkness, targets are visible for very short ranges and individual tracer control is practicable.

For a short period immediately after sunset, sights on

the guns can be used; in this case the precise methods of fire control are applicable.

Individual tracer control can be used after sunset, provided the target is partially visible. Flashes from the gun do not interfere with target visibility. To a limited extent the tracers illuminate the target, particularly when close to and below. On certain parts of a course the tracers reduce target visibility. This is true when they cross the line of sight from the gun, on incoming course, or on a crossing course while the target is approaching the normal.

The central control equipment: viz. the lead cables, telephone lines and other accessories do not interfere with all-around traverse of the guns.

The data computer can be traversed as rapidly as a machine gun, and when estimated initial data are used for the determination of leads, the time lag prior to arrival at the guns of computed firing data is very small.

The central control equipment can be detrucked and made ready for operation in four minutes or less when the carrying distance is not over 100 yards. This does not interfere with the use of the guns for individual tracer control.

Curves and Fast Balls at Leavenworth

By MAJOR E. D. COOKE
Infantry

CAPTAIN Bill Busher was nearing forty when he received his orders for Leavenworth. Despite a thin spot in his hair and a couple of partial dentures amongst his molars, Bill experienced something of the feeling of a small town player going up for a try-out in the big leagues.

Not that Bill hadn't expected the call. He and Mrs. Busher had scrutinized the names of all students in previous years and each time had secretly assured themselves that Bill was as good as any man on the list—and maybe a damn sight better. Nevertheless they could not suppress a certain smug satisfaction over knowing it was in the bag.

When his contemporaries congratulated Bill on his orders, he assumed as modest an air as possible. But he was baffled by a puzzled gleam in their eyes until he suddenly recognized what would have been his own outlook under reverse conditions. His brother officers were wondering by what freak of chance Bill Busher had been chosen for Leavenworth when they had not.

"Never mind," said Mrs. Busher, in discussing the lack of appreciation displayed by their friends, "You'll show them when you get to school."

"Sure," Bill promised, "I'm all set to burn up the course."

The School authorities remained calmly unimpressed by the arrival in their midst of so potential a ball of fire as Captain Bill Busher. While rated as something of a

You couldn't have all that education poured over you and not have some of it stick.

crowd prince back at the old station, Bill found himself of much less importance in the Leavenworth scheme of things than the sergeant over in the Book Department.

More than a hundred other students were present, rushing around buying supplies for the coming course. They all seemed to have been some "Old Man's" aide, adjutant, or favorite staff officer, but to the Command and General Staff School they were just another class washed up on the banks of the Big Muddy.

During their first few assemblies in Room 240, Bill indulged in some mental calculations. From general appearances and past associations he adjudged the ability of the group and assigned to himself a class standing. He didn't give himself any the worst of it either.

He compared himself to John Honest in the seat next to him. A good enough guy, but sort of dumb for Leavenworth, Bill thought. And on the other side was Charlie Earnest, with a pointed chin and his nose always buried in a book. Not much competition there.

"The hardest thing about Leavenworth is getting here," Bill informed his wife. "Even the instructors are adjutant."

His later statement was correct. The officers on the platform were doing all in their power to make things easy—at first. Like all old-timers they worked the kinks out

of their pitching arms gradually. They dealt gently with the new crop of recruits, coaching them in the fundamentals and basic principles—put everything right down the alley.

But Bill and his classmates got impatient. They wanted to see a marked problem—one of the fast ones they had heard so much about. They itched to dig their cleats into the sod and knock the old apple right over the fence for a homer.

When the eventful day finally did arrive, Bill found himself with little appetite for lunch. Giving up as useless the attempt to force Class I supplies through his esophagus, he proceeded to the problem room.

Smoking an endless string of cigarettes, Bill arranged his tackle-box, *Reference Data* and *Staff Officers' Field Manual*, all according to the approved School method. If colored pencils, trick doodads and excess paraphernalia could solve problems, Bill had all the answers.

The first situation and requirement consisted of four printed pages through which Bill read so hurriedly he had little idea of what was on them when he had finished. He went over it a second time with greater pains. Gradually the problem took shape before his eyes.

It appeared quite simple, once the situation was analyzed. In fact Bill wondered why they made problems so easy. All one had to do was go forward to defend on the Bonneauville ridge, or back up and hold at Littlestown. That was all, but which was correct?

In a similar map exercise the School had defended at Bonneauville, but this situation had variants that made Littlestown seem more attractive. A direct parallel of what the School had done in the I.P. should produce an "S," but Bill was after bigger game. He wanted an "SX." But he couldn't be sure that a "U" would not be waiting for the fellow who withdrew to Littlestown.

Beads of perspiration sprouted gently on Bill's forehead as the well known "mental anguish" got him firmly in its grip. He sat glumly in the utter loneliness of a crowded problem room trying to make up his mind. He saw with a start that half the period was over and he had not reached a decision.

Taking a desperate hold on his courage he finally drew in a MLR around Littlestown. Then his nerve departed, suddenly, like water from a ruptured paper sack. He grabbed his eraser. The line was too far back. It was a sure "U." He rubbed and rubbed, replaced his brigade on the Bonneauville ridge and located the last establishment just before time was up.

Down in the assembly room at least fifty students were arguing the respective merits of Bonneauville and Littlestown. Bill regained some assurance from hearing so many in favor of the former. At five o'clock the School solution was issued. The overlay showed a defense at Littlestown.

Mentally, Bill kicked himself all the way home. The first time at bat and he had gotten a foul tip. He tried to appease his pride with the thought that there were more problems coming in which he would do better. His self solace was negligible in view of the fact that Charlie

Earnest and many others had hit it right on the nose.

The next test proved to be a question of logistics. Bill stumbled through a maze of field trains, unit reserves, collecting stations and cemeteries. He emerged with a headache and the conviction that he must have slept through some important conferences, or else had been too dumb to understand what they had been talking about.

That week-end the social functions of Fort Leavenworth resounded with cries of "what I did." While the ladies sat meekly in corners, their lords and masters formed a circle around one pseudo general who expounded earnestly on his solutions. The others listened with strained expressions, not to what he was saying, but for him to cease talking so they could begin.

"Is it always like this?" Mrs. Busher timidly inquired of an instructor, "Don't they pay any attention to all these pretty ladies?"

"For the next six months they wouldn't look at the Queen of Sheba," he replied, "They want to talk problems. Nobody cares what they did but the marking committee, and all solutions give them a pain."

Judging from the wails and moans that arose when the first batch of papers were returned to their authors, it was evident that the instructors had commuted some part of their suffering to the students. Bill was more than satisfied to escape with two skinny "S's" and a lot of plain and fancy red crayon scroll work along the border of his papers.

From then on problems began to come regularly at the rate of two and three a week. Between times there were conferences that went off with the vociferous vibrations of a machine gun, and map exercises which proceeded with the stately cadence of a funeral dirge. The instructors were beginning to warm up and some of them began pitching curves. After each problem there was a formal discussion.

"Why they call a monologue a discussion is more than I can see," John Honest grumbled after one such séance, "And why was that fellow so sure that his solution was the only proper one?"

"Why shouldn't he be sure?" demanded Bill. "He could call a strike, even if it went over the back stop. He's not only the pitcher, but the umpire as well."

"Then I wish I'd had a pop-bottle to throw instead of an argument. Some of his decisions were lousy."

"Sure," Charlie Earnest agreed, "But a School solution has all the virtues of a textbook—approved before issued."

"But how did that major know he had the right answer? He never commanded a division."

"Of course not. But his problem wasn't original. It was taken from Wilcox's delay of Sedgwick at Chancellorsville. A few tanks, airplanes and chemicals were thrown in to make it modern. So you see, you got it by proxy from the actual commander."

"Did you figure that all out in the problem room?" Bill demanded.

"No, unfortunately. I thought it was Jackson's pursuit of Banks in the Shenandoah."

"Then you are dumber than I am, because you read a lot of books to get a 'U' and I just went in and got one on my own hook."

"That's a nice thing about this school," said John complacently, "They talk hard, but they mark easy."

"If they didn't, none of us would get to first base," said Bill.

With such banter and the interchange of ideas, much of the spirit of competition was removed from the minds of most of the students. There was more of golf and less of school mentioned at the week-end parties. A few would-be Napoleons remained, but they were more pitied than scorned.

For the most part the class was reaching the saturation point. They were satiated with knowledge. Their brains slowed down like a car forced into low gear on a steep grade. And just when it seemed they were completely stalled, the spring vacation gave them a short respite.

"From now on we're going down hill," said Bill.

"Yeah," John agreed, "I'm afraid I'm going too fast—on the toboggan slide."

"Nerts," retorted Charlie, "You haven't gotten enough 'U's' to shoe a horse."

"It's not that. When I first came I expected to graduate One in my class. About Christmas I'd have been satisfied to be in the middle, and now I hope I'm not last."

"That goes for all of us," said Bill, "But pull up your socks. We're on the last lap."

The last lap was a tough one. The weatherman turned on the heat and so did the instructors. In addition to the curves there were fast balls, slow balls, and even spit balls. Some of the pitchers were ambidextrous and didn't let their right hands know what their left hands were doing.

Bill and his mates were still in there swinging, but they began to hope the game would soon be called on account of they were getting a little dizzy. And just when the course seemed interminable, when it seemed they would spend the rest of their service in the shadows of Sheridan Ridge, the last reconnaissance was made, the last G.T.E. turned in, and Bill and his friends assembled in the club tent for a glass of beer.

"Well," said Charlie, "There goes one of the most important milestones in our military career. I wonder just how much we got out of it?"

"I dunno yet," said John. "My brain has taken an awful flogging. I'm too numb to know much, if any, I've learned."

"Numb, or dumb, you couldn't have all that education poured over you and not have some of it stick," said Bill.

"But couldn't a fellow get the same results by doing a lot of studying for himself?" Charlie wanted to know.

"Maybe you could," John conceded, "But I know never would."

"Then you figure you are a better officer for having come here?"

"A hell of a lot better. But that doesn't mean that I believe myself to be better than all those other fellows that haven't come here."

"But you are going to have 'graduate C. & G. S. S.' after your name in the Register," Bill pointed out, "And the other fellows can't laugh that off."

"What of it? I've got D.S.C. after my name, too. No one ever took exception to that."

"Why should they?" said Charlie, "Sherman said you can get all the heroes you want for sixteen dollars a month."

"Sure," agreed Bill, "There's a lot of difference between getting cited for bravery and for having brains."

"Yeah? What's so different about it?"

"Well," Bill finished his beer and stood up, "If you're brave you will drive into your new station, blow cigarette smoke in the 'Old Man's' face and tell him that if he needs any help, you have just graduated from Leavenworth. On the other hand, if you have brains, you will remove your Leavenworth license tag, go to the adjutant and tell him you're reporting in from a tour of D.O.L. up in Kansas and would he please give you a job as Post Exchange or Police Officer."

"All right, wise guy. I don't smoke cigarettes and I haven't graduated—yet."

"Unless you play golf on the polo field, or ride a horse over the golf greens, the chances are you will graduate," said Bill.

And he was right.

Inced in heavy woolen uniforms they ascended the graduation platform, saluted and clutched the hard-earned sheepskin in sweaty hands. They tarried not on their departure, but took out immediately for the four corners of the world. They had been to Leavenworth.

As Bill steered his car between the cannons on Grant Avenue, it gave a great, forward lurch.

"What was that?" cried Mrs. Busher.

"It's all right, Sweet." Bill reached over to ruffle the skirt on his wife's knee, a gesture he had indulged in very seldom of late. "That was just the corps artillery, tanks, chemicals and whatnots dropping off from around my neck. We're back in the bush leagues again."

AMONG SIXTEEN of the leading nations of the world, the United States ranks first in national wealth, second in total area, fourth in population and sixteenth in total trained military forces.



The Day Before Cantigny

BY MAJOR EDWARD S. JOHNSTON, Infantry

ESCROW'S NOTE.—This article is a record of events that actually transpired in the 28th Infantry during the preparation for the attack on the German lines in the vicinity of Cantigny. The conversations are as nearly verbatim as the author can recall after a lapse of eighteen years.

THE village lay just within the enemy's front line. It was at the farthest bulge of a great salient, that historic salient which marked the high tide of the German drives of March and April, 1918. There had been fighting back and forth to see who would hold the plateau. The French now hung on only to the fringe that gave them a meager defilade for Death Valley. The Germans had the high ground, but the Doms was at their backs, and, as Ludendorff later wrote, they would have evacuated the Doms-Avre bridgehead except that this would have indicated that they had given up hope of taking Amiens.

Up there at Amiens, a few miles to the north, there was still desperate local fighting. But the great battle, though the Allies could not yet be sure of it, was really expiring in a series of intense but final spasms. Amiens was now actually safe enough—but only the Germans knew it.

The French had entertained the idea of putting the Americans in at Amiens. But this was to be the Yanks' first taste of severe combat, and Amiens represented too much of a gamble.

The High Command could afford to take no chances. They were desperately anxious for an initial American success. It was necessary to Allied morale. If the untried Americans went in at Amiens and were overrun. . . . No, it wouldn't do. The Americans must hold their own. More than that, they must attack the enemy. Be it for ever so little, they must push him back. And so the attack could not be allowed to fail.

All this called for a nice calculation of politico-military

values. And the Frawgs are very good at that. They know how to fix things up to put in the newspapers.

Cantigny was simply ideal for this purpose. The place was not in the path of any probable German offensive. A case could be made out to justify, tactically, the seizure of the entire plateau. Besides, the terrain afforded everything needed for the assembly of overwhelming means to insure success, and, from three sides, you might say, the Allied cannon could pour their stuff into that hapless village.

Yes, it was a grand place to put on a show for the benefit of Allied morale. And such a performance was needed. For when the fighting front swayed back and forth, physically, the home front did the same swing psychologically; and something had to be done about it.

It seems a little strange, now that the thing is over, but at that time there was some honest doubt about us. People in Europe were really worried over whether our troops could stand up to the punishment of fighting in the first degree.

The Allies themselves had not stood up too well. The year before, the French had mutinied. Then Russia fell out. Italy took a terrible beating. And now the Germans had inflicted heavy losses on France and Britain.

The British had cracked badly in the Lys valley. They were, themselves, openly bemoaning the fact that the bulldog breed had about played out.

In fact our late associates had, at that time, a bad attack of the jitters. And not without some justification. Of course they prefer to forget all that, now. But the pooh-pooh business was not in order, then.

• • •

There was a War on.

Since many of you brave young men were in short

pants at that time, it may be worth the effort to say something about it. You can pick up the oddest notions from reading some of the books—and also from some of the people who are informative on the subject.

Some would have you think that the soldier spends his time in shuddering horror, while the War rages around him. And others would have you believe that a real man goes joyfully to combat—and thoroughly enjoys himself while he is in it. Oh well—or, oh hell, for that matter—to take a balanced view of anything is about the most difficult thing for a mere human being.

You have seen pictures of General Pershing addressing the officers of the Division before they departed for the great Battle. You may have noted a certain lack of Napoleonic enthusiasm on the part of that gathering. People seem to be rather serious. Well, it was a serious business.

On the other hand, you search in vain for an atmosphere of gloom. No doubt some gloom was there; but it was pretty well concealed. There was even a certain air of anticipatory interest. And why not? The Great Battle was bound to be interesting.

No. They didn't rush joyfully. Nor did they shudder.

They were pretty average, well-disciplined, regular soldiers.

Most of them were brave—as most men are. And most of them were also cowardly—as most men are. Most of them, like most men anywhere, were to prove themselves lions of valor at one moment and poor fearful wretches at the next. And this might depend on what they had in their bellies, or on how tired they were, or on the weather, or on what some one said—or on a lot of other things as to which we, ignorant of ourselves as we are, really know very little.

Most of them went to the Battle because they were soldiers; because it was ordered; because it was fitting; because it was expected. They were themselves in doubt as to what they would do to the Battle, and what it would do to them. They did not know, themselves, whether they were brave or cowardly—and never did find out. When almost all are heroes, and nearly every one is frightened, how is a "fella" to know?

One thing they were to discover: that few men are not afflicted by fear or disgust. Further, that these few deserve little credit. They are made that way. Most human beings have their bad moments, but still can carry on. These are the brave men. And that is why most men are brave.

Almost to a man, then, our people feared the War. Yet they enjoyed it, too. Almost to a man, and in a deep and voiceless way, they loved their life together; their comrades, their Battalion, their Division.

The question really was, for most of them, whether at the moment they loved these things more than they feared the War.

Their preparation was far from perfect. We ought to do much better, now.

They were drilled a bit too well in straight lines and formalism, and a thought too little in the crafty calculation which, combined with swift and sudden action, is the thing in war.

They had yet to learn that a heavy casualty rate may constitute a reflection, and not an accolade of honor. For many were destined to be too thoughtless, throwing themselves away. While others believed still that war is a brave game of grown-up children, like the playground sports of peace. There was to be need for that Division order which pointed out that bravery is not bravado, and that a brave man does not disdain cover. Yet these things take time in the learning. So we were to leave behind us, wastefully, too many of those OD huddles dotting the wheat fields. There were to be more than enough of those daring rushes across the open. There was to be too much of that steady upright marching through the wheat. There was to be too much raw courage, and too little seasoned craft, until, by sad experience, they became adept at the purposeful stealth which brings results in a war.

So that, young fella, if you have to do what they did, perhaps you will make use of your better opportunities to learn, in peace, the things they came to know in war by trial and error. In any case, there should be no worry about youth and inexperience. Nearly every one in the Division was inexperienced. And if, perhaps, you think of them as old-timers, a whisper in your ear:—most of them were younger, then, than most of you are now. And, anyhow, youth is no handicap in war. Youth is the time of lightning speed in thought and action. When we were young, we thought—and acted. When we are older and begin to become unglued, we think—and write about it.

Oh, well! The only thing to do is to wait and see. If history means anything, you will do as well as they did. And very possibly some day a Monument will be erected to commemorate your doings. Then you—if you are not a name upon the monument—can go and muse upon it, and meditate on the brave deeds inscribed upon its sides, and on the brave men whose names are there preserved. And when your old comrades quarrel mildly with you, you can amuse yourself by caustic comment on the ill humor of old age, and by dark hints that the world might have been a better place if certain different names had been inscribed upon that Monument of stone.

* * *

The Major was dead.

Four words will state the fact, but forty thousand would not express the numbing blow it dealt to his Battalion.

It has been said, "No man is indispensable." Well, some, no doubt, are not. But some, if at all replaceable, can be dispensed with only at great cost. What that

cost would be, aside from individual grief and pain, was now much the question.

How to replace in one man all The Major's qualities? His knack at moulding minds, at shaping bodies. His buovent humor that took due account of fact, and yet made danger into an adventure. That calm efficiency, unhurried, swift, unruffled, which had formed a thousand men into a single mechanism. That open eye for the new, the untried, the unconventional. That detailed, skilled, and practiced knowledge based on eighteen years of roaming, fighting, and campaigning, topped off at last by two years of the War in Europe.

Over this virgin battle ground the opposed artilleries growled and spat and thundered. Across the lines they flung their shell at anything that moved. The hostile cannon even sniped at individuals in the wheat and on the by-ways. They concentrated on the smallest groups moving within their range in daylight, and pursued single ambulances down the roads with malevolence and fury.

It was an active sector.

As to communication trenches, there were none at all until the veriest essential were hurriedly constructed. Over great areas, movement had still to be on the surface. The villages and woods were shelled and gassed until our harassed infantry, even two or three miles behind the line, took to new trenches and to shell-holes in the open. The organization of the forward area was primitive, no less. And so it must remain, with shallow trenches, practically no dugouts, almost no wire, while farther back work was pushed on the new battle position where the main defense would center.

Work, work, work, and shelling all the time. The ground was usually a-tremble. Men were little burrowing creatures that scampered through the herbage, scuttled along walls and hedges. Even at night they must be always on the dodge, or be dumped unceremoniously like limp brown rats beside their pathways. By day, men went to earth.

The untutored onlooker would have cried, "Listen to the guns! They dominate the situation!" But, in cold fact, in spite of all this racket and this danger, they did not. For the guns could exist at all only because their infantry, scattered in their tiny shelters, were there to halt the enemy infantry, to deny them access to the battery positions.

Matériel seemed everything. But it was really nothing, without men.

* * *

The sun of that bright May-time shone upon a world of rippling wheat: young wheat, its green becoming speckled with the chalk thrown up from shell-holes.

The little villages, above their deep wine-cellars, rocked with great concussions, stank with gas, and slowly sagged into the rubbish-heaps they seemed doomed to be.

The white moon sailed above a world dimmed but not darkened, peopled with furtive shadows—workers, carrying-parties, and reliefs.

And the Battalion moved from reserve, forward toward the front.

Straddling Death Valley, it stared upward at Cantigny. It burrowed away from shell-fire. It dodged about the area by night. It ate one "hot" meal a day, while the hostile airplanes bombed the roads, photographed the new positions, and adjusted for their artillery.

"I love to see the men getting so quiet and so hard," had said The Major.

They were fast hardening into seasoned soldiers, now. They kept their daily casualty rate quite low, "hid out" from enemy airplanes, worked at night, and by day added to their scanty shelters.

Yes, it was an active sector.

* * *

New trenches were to be constructed fronting on Cantigny.

All the platoons that could be spared went up to dig. One night Death Valley crashed with shell-bursts, and, while some platoons went through, a few of them came back.

That was an unhappy time. The guilty went to stand before the Colonel in his lair. The terrible Old Man! They trembled as he glared at them. Eyes that shot sparks, and a voice that was a portent.

He knew his business. First he thundered at them—rumbled and cracked and flashed with lightnings; till they wondered how they could have been so concerned about shell-fire, when the alternative was to face *this*. Then he soothed them with questions; then terrified them anew with devastating comment. And then lifted their spirits with an appeal to them as men and soldiers. They vowed devoted conduct for remission of their sins. "We'll forget it," said the Colonel.

"Captain," said one of the culprits, shaking with relief, as he came from the Presence, "all excuses aside, there is an explanation. A man ran up to me in the excitement. He gave me an order to go to the rear. He gave it as from the battalion adjutant by name."

"What the devil would the battalion adjutant be doing there? Your orders come from me."

"I know. Yes, sir. Things were mixed up in the confusion. . . ."

"And you never obey that sort of order unless you're sure beyond a doubt."

"Yes. I know. I realize now."

"You weren't with us long before The Major died. A thing like this—and known outside the family—it couldn't happen in *his* day."

"I swear I'll make up for it, Captain. You can be sure of that."

"Who was the man?"

"I didn't know. I've tried to think. Not one of mine. And not one of the old men in the company. If he's with us, he is a new replacement."

"We'll look them over."

They checked them over, and warned all concerned. But they did not find the man—at least, not then.

The platoons went forward nightly to the plateau. The Captains put them on the tasks outlined by the engineers, and moved about among them. Parts of the new trenches were on the flat top of the hill, and here they must be started in the open, under fire of small arms and machine guns.

The company detailed to dig the forward parallel filed up the approach trench, made a column-left into the old support line, right-faced toward the front, clambered out, and then advanced across the open, stumbling over the rotting remnants of Moroccans who had fought here weeks and weeks ago. Then, having reached the tape-line, the workers unslung their intrenching tools, and the dirt began to fly.

But X Platoon and part of Y were missing. Then shells began exploding in the area. The Captain hurried back down the approach-trench, picking his way among the engineers now crowding it to escape the shelling. He came out into the open above Death Valley. Still no sign of the missing. He hurried down the slope—and met them coming from the Valley.

"Captain," Lieutenant X reported, almost in tears, "the thing has happened again."

"Not so bad; you're in good shape, though a bit delaved. What happened?"

"We were in the trench, going forward. The bombardment started. The engineers crowded into the trench, and slowed us. Then an order came in your name, passed down man by man. It was an order to move to the rear."

"Did you check it?"

"Twice. It came back each time, clearly; the last time it was emphatic. I could hardly believe it. Still, the shelling might have changed plans. And if this was so, you would want quick action. I started the platoon back down the trench. When we got to the open, I was stopping to check up when some one shouted 'Double Time!' The men took up the double. They thought it was from me. Then some one yelled 'GAS!' . . . Well."

"It took a little time after that to get a line on things."

"A half-hour or so. I found all of my men and about half of Y's. Here we are. Whoever did it, he's devilish clever. And he's in Y Platoon."

"We'll find him!"

But they did not find him—that is, not just yet.

The work went on.

Officers stood on the top until the men should be dug down under cover. Buglers and runners declined cover while the officers were exposed. A bugler was struck by a fragment at his belt buckle; twisted half around, he

was knocked down. He rose with a big bruise at his middle, and a cold rage in his breast. "I'll pay them for that some day."

A man grunted suddenly in the dark, and a sergeant said, "Sir, there's a man hurt here."

"Send him back if he can be moved. No one to go with him if he can walk."

"He says, Sir, it is through the shoulder. The Major would have called it a blighty. He can still help out."

The work went on.

Daylight came each day to find a deserted landscape. At night, the work went on again.

* * *

One afternoon the Battalion Commander summoned the Captains, showed them a map, and said, "It may be ordered that this regiment take Cantigny. If so, then this is the plan. . . ."

Then, from the Colonel, dusty in old clothes, in which he had been roaming over the forward area: "In two, three days we go out for training. In the meantime, each company commander reconnoiter approaches to his assault position. Pick out routes for use by night or day, off the main ways of travel. Mark them. Check your assault position. Go up to it several times, by night and day. Stand in the center of your departure trench, and look over your field of battle. Note your objective. Take a compass bearing on it. Pick out some prominent objects to guide on—something shell-fire won't destroy. Study the ground and map together. Mark the flanks of your assault position with stakes that can be identified at night. . . . Here, Gentlemen, get under these trees in a hurry. God-damned scoundrel!" cried the Colonel, shaking his fist feelingly, as an enemy airplane whirred over their heads, "Coming over to take pictures!"

The conference broke up, and in a few minutes the enemy artillery shelled the spot where they had been. Hit it, too.

* * *

That was a lively time of training.

They studied maps, pored over aerial photos, and meditated over a mud relief-map of the town and its environs. They marked down enemy trenches, noted dugouts to be bombed, and told off parties for the bombing. They met their cooperating tank units and practiced with them. And then, with tanks and flame-throwers and all the paraphernalia of attack, they rehearsed the operation on ground like that over which they were to attack in earnest.

They attended conferences, and listened to explanations. A distinguished French officer painted for them a vivid oral picture of the support by the artillery. The Corps Commander, a little old Frenchman in Colonial uniform, gave them some brief advice.

And they wrestled mightily with a host of details—extra canteens, extra picks and shovels, so many sand-

bags, so many grenades, pickets, rolls of wire, extra ammunition, and so on.

Then came the order for the Battalion to go up twenty-four hours early, take over the front of attack, and cover the assembly of the regiment. They were to see the other battalions exactly set in their assault positions, and then take up their own in the new parallels of departure, evacuating the crooked old front line at "H minus 2." (Mark that time well, reader; mark it well!)

Hurry, hurry, hurry! the pressure growing with each hour. Then a last conference. They pressed about the Battalion Commander, anxiety in their voices, asking this and that. "No;" he replied, "I can't find out about this, or this, or that. No, Gentlemen, I have done my best, but everything is in a last minute rush, and no one seems to know. I know things are in a mess." Then he smiled, resignedly, "The truth is, this old Army of ours, it seems to me, is in a hell of a mix-up."

They stared at him a moment, in nothing less than astonishment. It was the first time he had ever as much as said, "I can do no more. I depend on you." Then they chorused with enthusiasm, "Oh, we'll be all right, Sir. Don't bother about these little things. We'll look after everything!" And they hurried off to get things set before the camions came to town.

The French tank officers dropped in for a last visit. Those gallant fighters! To them, an attack was an old story. No bother. No fuss and flurry. Obviously, they wanted to open a few bottles with their comrades, *les Américains*. And how the *Américains* would have loved it! But—there was no time for anything but hurry.

The trucks arrived, but not enough of them. Everything else arrived, too, but not enough of anything. Except the guides—and there were simply none of them at all! There was a fearful tension. But at least the men were under no great strain; the officers saw to that. And the Battalion, entrucked, moved off upon the minute.

Then the long and quiet ride, in the cool dusk and early evening. And the long hike forward to position. Still no guides, but who cared? This relief business was an old story. They knew it to a T—The Major had so carefully taught it; they had so often done it. The artillery barked and screamed and crashed as usual, and from midnight on the enemy's gas-shell—an omen, that—warbled overhead and thudded into our battery posi-

tions; but the relief went off without a hitch, and every man was in his place by dawn.

"Captain," said the Second-in-Command, as they settled down in the command post on the rim of Death Valley, "You've put X and Y Platoons in the front line from right to left. I didn't want to bother you while things were in such a rush, but *they* are the ones who had this recent trouble."

"That's why I put them there. They're looking for trouble. We got raided our first night in the Toul Sector. It may happen again."

"That's what I mean. We were on our own. The wires went out. They pounded us hard. It was next to impossible to move at all. The platoons were cut off from each other. Everything depended on every one holding where he was till things got straightened out."

"X and Y will hold."

"You remember, Captain. We didn't howl for help. We did our job, and so did the other front-line company, without alarming the whole Division front. The Major was pleased, and said so in writing. If it happens again, we want to do it that way again. That's why I'd feel better. . . ."

"They'll be all right."—The Captain yawned.—"They're good and sore about the mistakes they've made, and they're steadier for it. I remember The Major once said. . . . Well, never mind. Suppose we—go—to—slee-cep."

The bombardment seemed to drop to just a mutter, and then was only background for their dreams. The gas sentry, just outside, shifted, coughed, and sighed. The gas shell whistled overhead. And a bunch of youngsters snoozed away, under the good old moon, in France. Maybe there wasn't a War on—for a while.

* * *

"Captain," said the Second-in-Command, shaking him with determined diffidence, "Captain! Listen to *that* racket."

"It's a plenty," agreed the Captain, sleepily, "and more or less all around. *How is it, Sentry?*"

"Tear gas everywhere, Sir," replied the gas sentry, his voice muffled in his mask. "And some HE."

The Second-in-Command motioned to the Liaison Officer, who, as guide and mentor, had been left in the Line by the relieved unit, to remain with the new garrison for twenty-four hours. "Lieutenant Hangover, here,"



"Our own artillery is firing on our trenches."

said the Second-in-Command, "says that this is heavier than usual."

"Yes, it is," averred Lieutenant Hangover. "But I wouldn't say that means so much. The old place has been looking up of late."

"I didn't want to wake you up, Captain," explained the Second-in-Command, "just for a bombardment. But . . . well, it may be something more. Just as happened to us before."

"Puts one in the same old dilemma," said Hangover. "If you go out and it's just a bombardment, you get your head bashed in or lose a leg—and feel all mad about it. And if you don't go out. . . ."

"If you don't and it's an attack," supplied the Second-in-Command, "then you feel worse. Funny! This is a real war, and yet that's not in any of the books."

"I told my captain," said Hangover, "we were too far back here. All right for that Moroccan company commander who dug in here in the first place. But. . . ."

"But not all right now," affirmed the Second-in-Command. "not with all that's coming off these days. They could over-run all four of our platoons, and we not know it—till they came in on us. And if we as much as lose one prisoner! Captain—every man in these two front-line companies knows all about the attack we're going to make. Suppose we lose *even one man*?"

"They know just what to say and what not to talk about," replied the Captain. "The Major taught 'em that. But you're right. Any one *might* talk."

"They've got no business putting an outfit in the front line ahead of time, that knows a thing about plans for an attack," declared Hangover. "It's poor tactics, *I* say."

"It's our problem," remarked the Captain. "Heavy shelling on the right, too."

"That's OK," said the Second-in-Command. "If they raid the regiment there, it doesn't matter. They don't know anything about the attack. But—we should be farther forward."

"You can't change the location of a post of command," said Hangover firmly, "not without permission. That's one of the things I'm here to tell you."

"But we can establish an OP on the plateau, with a chain of runner-posts to connect us," said the Captain, "and I can stay up there until after stand-to hour. Turn out company headquarters."

There was a fine place for an OP just up the slope, a piece of trench with a good view to the front.

The commander of the French tank battalion came uphill, hands in overcoat pockets, looking about him in the cool and murky dawn. A plump and placid person, he gazed toward the front, where, in the dim middle distance, shell were dropping thickly along a trench.

"The Boches are going to attack?" he asked.

"Oh, no. *mon Capitaine*," replied one of his officers, a tall lieutenant who was busy with a line of guide-stakes. "That is our artillery. I have just come from our front trench, and all is quiet there."

"And stand-to time is over," commented our Captain. "You buglers keep your eyes open."

He moved downhill to the dugout. "Now!" he said, "daylight's here, and a fella can get some sleep. Call me if anything happens, but only then. . . ."

* * *

A runner came from the front, sprinting and dropping, rising and running on. Where the approach-trench ended, he made a dash across the open, dropped to earth as a shell fell crashing near him, and rose to run again. He tripped over the gas sentry, now flattened out on the ground, and fell into the dugout. "Jesus!" he breathed.

"Watch yourself!" rebuked the Second-in-Command, sharply. "You'll wake. . . ."

"Humph!" interrupted the Captain, ironically. "Of course I'm sound asleep. All this commotion," he added irritably. "Don't you know how to enter the Orderly Room?"

The runner grinned sheepishly. "From X Platoon, Sir," he reported, saluting. "The Lieutenant says, 'Our own artillery is firing on our trenches.'"

"Our own artillery!" exclaimed Lieutenant Hangover. "But that doesn't happen. Not with *our* artillery."

"Thing to do," offered the Second-in-Command, "is to move them out of there."

"Can't evacuate a trench," Hangover told them decidedly. "Not without orders from higher authority."

"We can if I say so," declared the Captain, with some asperity. "I talked this kind of thing over with The Major, long ago. He as much as told me that an order like that, never to change position, is silly. He showed me what to do."

"Seems to me," mused the Second-in-Command, "that he said to pull them back to some other trench, or put them into holes between them."

"Or even out in No Man's Land," added the Captain. "Anywhere where they can still accomplish their mission. . . . Here, runner; how are things up there?"

"Pretty bad, Sir," replied the runner.

"Take this," the Captain directed the Second-in-Command, as he scribbled a message. "Send it to Battalion by two runners, separately. I'm going up to look at things."

But the whole outdoors now seemed to erupt explosions. They was a shouting, just outside. The gas sentry, rising to his knees, was pushing aside the door-blanket. "Lieutenant Bomb, Sir," he announced, as a Battalion staff officer burst into the dugout.

Lieutenant Bomb had once commanded Y Platoon, and his heart was still with it. Among his youthful colleagues, he appeared, to the casual eye, more youthful yet. But a youth of this sort becomes a veteran overnight. He had the soldier spirit, and to be a capable unit commander in the midst of things was his great ambition. Sudden appearances, when things were happening, constituted one of his specialties, but the courteous calm of our distant Southwest was his usual demeanor.



Picked themselves up from the trench-bottom.

He reserved animation for times of great emergencies. And this was one of them, for rarely had he been seen in a state of so great excitement.

"Captain," he cried, his eyes flashing, "wounded are coming back into the aid station. They say the Boches are attacking. One man told the Surgeon he saw 'their bayonets gleaming.' The Battalion Commander wants to know about it."

"Runner from Y Platoon, Sir," said the gas sentry.

The runner gave a sharp salute. "Lieutenant says Boches are attacking," he reported, simply.

"Notify Battalion," ordered the Captain, as he left the dugout.

"We're needed up front," exclaimed Lieutenant Bomb.

Then they ran uphill.

The runner-posts had heard nothing from the OP.

The OP was a mess, and the two buglers, splashed with chalk, picked themselves up from the trench-bottom, apologizing.

"A big shell bashed our *trench* in," cried one.

"You!" Lieutenant Bomb spoke with feeling. "Some one should bash your *head* in."

"The Frenchmen all ran," explained the other bugler, "and a lot of other people, too."

"Why not?" replied the Y Platoon runner. "But you—you were here to see things and report 'em!"

"We'll do better next time," promised one bugler (and they did).

The Captain had gone on to the front. They ran to overtake him. Shell still fell upon the plateau, and the approach-trench was a kind of has-been. Here it was a series of great holes, and there it was a row of small hills.

They passed the two support platoons. Near by, an impassive soldier, extricating himself from a wrecked shelter, was gingerly avoiding a large minenwerfer dud, which he regarded with pronounced respect.

"All OK here," reported one platoon commander. "But X Platoon, in front, caught hell. Our own artillery was firing on them, too. It's stopped, thank heaven. I'm all ready to counterattack, but I don't think I'll have to, now."

From the front came the popping of rifles, and the broken chatter of a machine gun.

On the left, in the front line, the trench of Y Platoon seemed undisturbed.

"Everything all right, Sir," reported the platoon sergeant. "We lost no one, and have a wounded prisoner. But X Platoon is not so good."

They turned into the X Platoon trench.

Well. . . .

Well, lads of the post-war era, you have read the war books, and you have heard of scenes of this and that.

That was it.

Not to dwell on gory detail, it was not a trench, now, but a ruin. There was Private Dumjohn, a gloomy sort of soldier. He seemed to stand embedded to his chest, paler and gloomier than ever. And then you saw that he was not embedded. Not a bit. And there was Sergeant Whoosis. A fine and handsome soldier, a good man, and, like his spiritual double, the domestic Tomcat, much given to lone prowlings, especially when in Billets. Well, he'd never prowl again—not in two pieces.

But why go into all that? It was just what happens when a Doughboy platoon mixes it up in a war. Find out for yourselves, in due course.

The men of X Platoon were scattered all along their line. They were shaken. They were twittering. But they were on the job.

"Those two replacements there, Sir," said a corporal, proudly. "They're sure good shots."

"Losses about half, Sir," said the sole remaining sergeant. "I'll check up again. I can't find the Lieutenant."

Scattered figures were moving over No Man's Land. Here and there they were dropping. A machine gun was near by, hidden in its clump of bushes. A lieutenant pertaining to it now emerged, snarling, and called on the riflemen to cease fire. According to him, it was now time to stop fighting. But, as it happened, he belonged to a unit not yet relieved, and so apparently was not aware of the attack scheduled for next day. But the riflemen were all aware of it; the thought was much in their minds. They looked to their own officers for orders. And these knew well that there were Frenchmen, engineers, advance parties from the other battalions, and strays from here and there, all of whom had been scattered around the sector, and many of whom knew about



"Let 'em come on."

the plans for next day. Suppose even one of them was taken prisoner? And talked? In the dim obscurity of fog and dust and shell smoke, those figures to the front could not be plainly seen. Best to take no chances. So the popping of rifles still went on.

It was just as well. The German records tell us that their raiding party had taken two prisoners, but that the Americans, firing on everything that moved away after the attack was over, killed these two before they could be pulled into the German front-line trench. To what unit these prisoners belonged has always been a question. At any rate, *they never talked.*

That was the important thing.

Well, life is real, life is earnest. It had been a bad day for the *Jagdkommando*, the Raiding Unit of the enemy—th Infantry. On the body of the leader of the ruined *Jagdkommando*, our people later found the orders for the raid. These, as models of their kind, were published by the French High Command and by GHQ, AEF.

The plan was detailed; yes, and thorough.

To the south, the *Chemin des Dames* offensive was to start that day. So, near Amiens and elsewhere there were to be demonstrations; incidentally, raiders would seek prisoners and "booty." From midnight on, here at Cantigny, there would be counterbattery with gas and HE. After 5:30 the enemy would shell the whole plateau. After 6:30 they would concentrate on the front line with artillery and *minenwerfer*. At 7:00 A.M. they would lift the preparation fire, and put a "box" around the area. And at this hour, the *Jagdkommando*, debouching from its trench, would move to the attack, the center advancing on the junction of the front-line trench with the approach-trench which—as you know, reader—separated X Platoon from Y.

But there were a few things the matter.

For one, the preparation fire left Y Platoon almost untouched. For another, the *Jagdkommando* provided a certain discord in the symphony of the attack. The proper thing would have been to issue early from the trench, crawl forward under cover of the fire, and then, when that fire lifted, throw grenades and rush. Instead of this, alas for the *Jagdkommando*, they waited for the



He parried and lunged in one motion.

preparation fires to lift; then, too late, the raiders issued from their trench—some two hundred yards from ours—and moved to the attack, even inviting attention to their approach by throwing grenades before them.

"'y God!" exclaimed a man from Y Platoon, squinting along his rifle. "Those fellas are scardeer 'n what I am."

"Let 'em come on," ordered his platoon sergeant. "None of them will go back."

Few did.

One raider reached the trench of Y Platoon. There he clashed with one of the defenders, who parried, lunged, and fired in one motion—and took a wounded prisoner.

The parry deflected the attacker's thrust, also his bullet. The latter merely stripped the handguard from the defender's rifle.

"And some people say," mused Lieutenant Y, as his soldier proudly told his story, "that bayonet training is poo-bah, and that the parry is the most poo-bah of the bahs and poos."

"Some people talk a lot of nonsense," agreed the Captain. Well, he would have to put that in italics, now, after some eighteen years of peace. Peace is a great breeder of nonsense.

Another enemy soldier took cover near the Y Platoon trench, later to surrender. So two prisoners were hustled to the rear.

The little strip of straggling wire across the front had been no special obstacle to the *Jagdkommando*, but it had caused a trifling pause as each wave came upon it. The

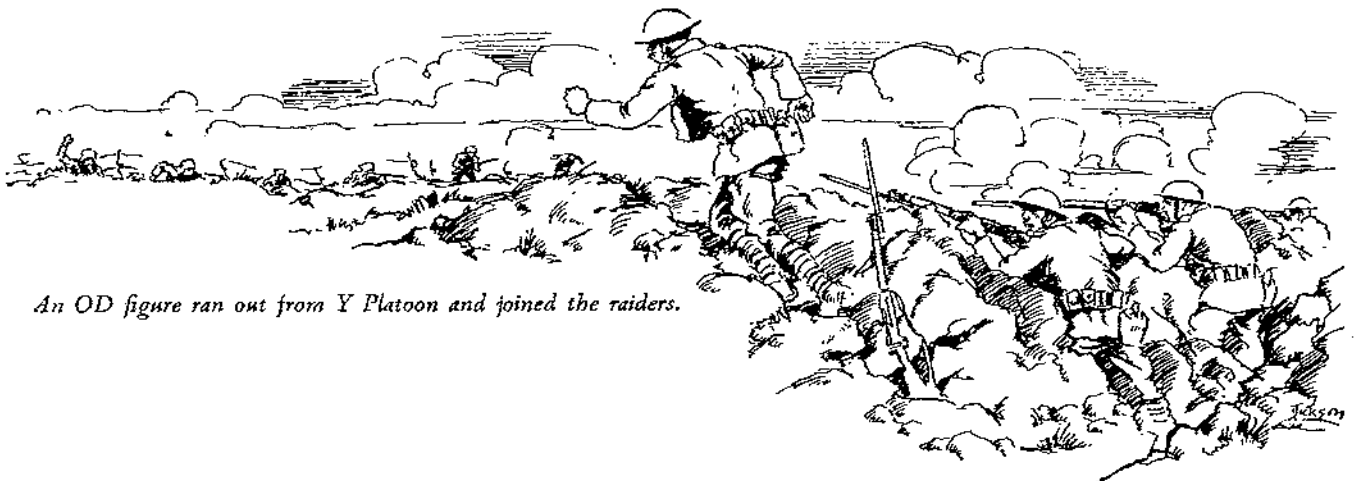

An OD figure ran out from Y Platoon and joined the raiders.

first effort of the defending machine gun was not too successful, but the second took the rear wave in enfilade at the wire, and cut down more than wheat. "That gun must have brought down more than twenty men," declared a soldier. Well, there were only some fifty in the Jagdkommando; so the machine gun accounted for a good part of them.

A group of five men reached a point near the head of the approach-trench. This was the crisis of the raid. For at this moment an OD figure ran out from Y Platoon and joined the raiders.

"He ran up to them," related Lieutenant Y, "and he yelled something. Whatever it was, it meant a lot to them. I guess it was about the attack tomorrow. They were certainly excited. One of them blew a whistle, and signaled 'to the rear.'"

"What happened then?"

"Most of our men seem to have seen this thing. And every one who saw it seems to have fired at them. All six of them went down. Must be there yet. We were careful not to let them crawl away. Couldn't let *that bunch* go—any of them."

"What happened to that man of ours, who ran out to them?"

"He's out there with the rest."

"He's here, all right," called a voice. It was the Intelligence Officer of one of the sister battalions. He appeared, now, suddenly, in No Man's Land, sitting in the wheat, industriously working at something. He was noted for roaming about the area, searching out this and that—a lesson for you, young fella, if you get a job like that. And he was to be killed the next day, sitting up in just this manner, sketching the enemy dispositions—another lesson for you, too.

"Who are they?" called the Captain.

"Lieutenant So-and-So of the enemy -th Infantry," replied the Intelligence Officer. "Also one NCO and three privates of the same regiment. And a Private Such-and-Such, funny foreign name, belonging to your outfit, Captain. And all simply *tiddled* with bullets."

"So that's the fellow!" exclaimed Lieutenant Y. "He's the one, then, who must have caused us all that other trouble, too. New replacement; just a month or so. Well, he'll be no more trouble, now."

* * *

Then they turned to, to restore some sort of order.

They never would have found Lieutenant X, except that some one saw a trickle of earth slipping down a tiny hole in the trench bottom. So they dug straight down, and there they found him, buried, pressed into a huddle by the earth about him, half-dead with shock and suffocation, one hand twisted out of shape by pressure, but otherwise unharmed.

"Did we beat them off?"

"We did."

"Lost no prisoners?"

"And captured two."

"Captain, we did our best."

"You did damned well. Now, back to hospital and a good time for you."

Queer how, when such affairs are over, the place suddenly teems with adventurers from elsewhere—curious, free with advice, and eager to be helpful. So, two lieutenants of the -th Infantry now appeared from nowhere, urging every one to do this and that.

"Better redistribute ammunition."

"You need a burying detail, now."

"Now, Captain, we'll call for volunteers to take the wounded back."

"The hell you say! You forget you're with the Regular Army. Volunteering be damned! Good idea for you to tie up your jaw and be on your way."

They grinned and interpreted his remarks to mean that they might stay. Unfortunate for them.

"I'll carry on up here," said Lieutenant Y, and the Captain hurried back to send in his reports.

That job was hardly done when here came Runner Y, again, to say, "Our artillery opened fire once more. Hit right in our line. Wounded Lieutenant Y. He's gone to the aid station. Killed one of those lieutenants from the -th Infantry, and wounded the other—bad. More of our men hurt, too." He sat down suddenly, this steady, brave, young soldier, and tears rolled down his face.

It was one of those moments.

A middle-aged French officer came toiling up the hill, to report some flame-throwers for the next day's attack.

"You've been attacked, *mon Capitaine*?"

"And killed 'em all, or most of them. But our artillery is firing on our own trench."

The Frenchman shrugged, that old, expressive shrug. "Courage, *mon brave*. All artillery is like that. It is the War!"

Yes, there was a War on.

Then comes Lieutenant Bomb, already gone back to Battalion, and now come up again.

"Captain, the Battalion Commander says he will stop our artillery or break some one's head. . . . He says the Battalion has done well."

"He does?"

"The reserve companies formed like veterans. They paid no attention to the shelling. Every variety of dam' fool loose in the sector went past them to the rear, yelling at them to run, the Boches were coming. Our people paid no attention—except to shoot at some of them. A dump blew up in the middle of one company. The men scattered out of the way, and then re-formed in a hurry. Our Old Man was much impressed."

"So he thinks we're all right."

"The other front-line regiment of our Division lost two prisoners. But that's all right. They knew nothing of the attack tomorrow."

"People from top-side bother Battalion much?"

"On the phone all the time. Looks as if everybody was keeping tabs on us—all the way up to Army."

"We need some help to get our wounded back."

"Stretcher-bearers on the way now. The Battalion Commander wants to share your dugout tonight till time for the attack."

"I'm moving up into the trench anyway. The -- Battalion sent me word I was to vacate; that their headquarters would move in here."

"The Old Man says you're to stay here. He outranks the -- Battalion, and will establish our PC here till the time to go over. If you can improve the dugout a bit today, well and good, but the main thing is for all of you to get some rest."

"It'll be fixed up for him in good shape; count on that."

"Captain," went on Lieutenant Bomb, the tears suddenly almost starting. "It was great! There'll be no more bother about a lot of things. You'll see. We'll be a family again. The Major, wherever he is, will be darn' pleased."

"Yes," said Lieutenant Hangover, coming back from the front. "It has been hell; but it's been great."

"What do you expect?" cried Bomb, aggressively. "Do you know what outfit this is?"

* * *

Fine young Bomb! . . . You old fool, — young? You and he were of an age.

Well, anyway, he was a top-notch. Always where he was needed. Did about everything there was to do at Battalion Headquarters. And a superior company officer, too.

You remember the day when a shell went over the road? And Bomb's whole platoon sat right down on their haunches in a bunch? He was so angry; the thing exploded a quarter-mile away. He raged at them, and waved his trench cane right and left. "Get up, God-damnit! Or I'll knock you down!"—Funny, maybe; or your Pacifist would shudder, "Prussian!" But his Platoon thought otherwise. For there were some tough cookies among them, and they knew a man when they saw one. They thought he was great stuff. So he was—and he was crazy about them.

And you remember those long serious talks? And those chats here and there over a bottle? And that joyous trip to Beauvais? (A little town, but a good one.) A man like that takes generations in the building. And then, of course, The Major, who never missed a bet, saw what was in him, took him on his staff, and put his special mark upon him.

Well, his name is on the Monument.

* * *

That night the Battalion Commander, arrived for the attack, remarked. "Things go well with us, after all, don't they?"

"Yes, Sir."

"I found out why they were shooting you up. The order said you would evacuate the old front-line trench by 'H minus 2.' The artillery got it as 'J minus 2.' Difference between two hours and two days."

"They thought they were **G**e to fire on it!"

"We ought to say 'J minus many **d**ay.' 'H minus so many **h**ours.' When this is over, that's a thing I'll recommend. And a lot of people will call it 'academic.'"

"Yes," agreed the Captain, little realizing, again, how often, it was to hear just such condemnation as the Old Man had heard of just such practical lessons, through the long, bright days of peace.

"You have to go, it?"

"To see part of the -- Battalion in position, and then shift my people to their jump-off place. Then I'll sleep till we go over."

"Come back here to get your sleep," said the Old Man.

The Captain saw the last things done, returned, and settled down in a corner.

"It was a queer thing about that man So-and-So," observed the Old Man, reflectively. "What do you suppose: a desperate cold calculator, or a misguided young fool? He must have been responsible for those other things that used to happen. False alarms, twisted orders, and all that. He did us all the harm he could. A fine chance he had, though, to do any real damage—with an outfit like ours!"

"Yes, Sir."

"Now, better get your sleep. I'll be up all night. Everything is going like clockwork."

The Captain woke with the crash of the artillery preparation. He slung and buckled his equipment, and gave the Old Man a salute.

The Old Man looked at him—just a moment, but something, a thought, a spark, passed between them.

"I'll see you at the objective," said the Old Man, casually. (It was there his clock was to strike.)

The Captain, in the bright early sunlight, climbed the hill again.

Troops crowded the trenches. The artillery shouted—no, it raved. Cantigny crashed and thudded like the end of the world. Tanks crawled up the reverse slope. Here and there the whetted edge of bayonets glittered; no fooling, they really did—they glittered.

But the Captain took it in with only half his mind. His thoughts were lingering in the dugout. "By God!" he mused. "The Old Man's face. Just for a moment. I could have sworn it was—yes, it was, The Major back with us again."

In the front-line trench Lieutenant Z was waiting. "Everything fine," he said, whirling his whistle about his finger. "Captain, it's a queer thing."

"Well, it's a stunning thing." The Captain pointed to the village, which heaved and retched across the way, and belched smoke and dust and flame into the heavens.

"I don't mean that. Something else. . . . You know, the men have always been dependable. But the last few weeks they've not been easy in their minds. Now . . ."

"Well?"

"Well, they know it's no picnic, but they're confident—and happy."

"It's a fact. We're a fact again."
The whistles sounded.

* * *

It was years before they reared the Monument to the Division.

It was more years before the Captain saw it. Then he doffed his hat, and mused. A thrill ran through him—that queer name, that seems to link you with a timeless past, and with as long a future. Somewhere, scattered over this wide world, there were still some fifty thousand men to whom that Stone meant something.

Yes, there they were, the names of the Heroic Dead; his people, too, among them.

He ran his eye along the list; then stiffened, flushed with surprise, and stung with anger. Why, how could *that* be? The name of that damned deserter. On whom he had rendered a special report—no, two, of them. Yet, there it was, inscribed in bronze, and set in stone, among the true men of his outfit.

And yet, —. He realized, after all. . . . It was not so bad. His feelings were not really outraged.

The man had done his worst, and failed. He had helped to make us what we were.

Perhaps the thing was fitting.

Who could the fellow be? Just a flushed, reckless youngster, loyal to those he thought of as his countrymen—those men, no less brave, no less devoted, on the other side? Or could he have been some one of military background, of professional insight, cool as well as daring, who knew what the thing meant?

What was it one of the Old Boys had said? And not so long ago. "It was a real crisis. The locality itself did not so much matter. But an American success did. And was to mean more than ever. Think of it! The Germans broke through on the Chemin des Dames on the day before Cantigny. From our standpoint, they could not have timed it better. Our success was to be the only bright spot in the whole picture of disaster. The Americans could deliver the goods! Looking back, it doesn't seem

to mean so much. But, at the time, it was everything. Paris and London were waiting, with bated breath, for news of us. Suppose the enemy had learned of our attack, beforehand, and had smashed up your regiment. That would have spelled something for our Division. For the other regiments must have been thrown in. That village had to be taken, not for what it was, but for what it meant, though every man in the Division died on that plateau."

Probably this fellow realized some of that.

How clever he had been. How quick to act upon the moment. Even those first two little incidents. And at the last. . . . He must have asked himself, was the thing worth it? what were his chances? if he put it over, or if he didn't, what would he have to pay for it? there was a near certainty that he would die. But there was a good chance that, even so, someone, warned by him in those few breathless moments, could get back with the word he died to bring them.

How easily it might have happened. And what a difference it might have made, at least to our Division.

Yet it did not happen; why? Because of days and weeks and months of careful training, of discipline, of morale-building, of practical instruction, even of clear-sighted prophecy. One could almost hear The Major saying, "When we get into the Line, remember this. . . ." And then again, "Remember that "

By God! they *did* remember. They bore him always in their hearts, and his lessons in their heads. Long ago, it seemed, he had told them everything they would have to do. When the time came, they simply did it.

Yes, the man had failed, failed before he ever started, because The Major, though buried in the chalk of Picardy for weeks, had thwarted him before he ever made the effort.

He failed, although he was a thinker, a keen courageous calculator—and a man of valor.

His failure was a Monument to us.

Now, he was Dead. And—yes—he was Heroic.

Let his name stay where it is.



Adjustment of Antiaircraft Gun Fire

BY MAJOR C. S. HARRIS, C.A.C.

THE obvious purpose of adjusting antiaircraft artillery fire is to place the center of bursts on the moving target and to hold it there. During the preparation of fire, corrections are applied for known variations in ballistic conditions and for systematic errors in the fire control equipment. During fire for effect, experience frequently has shown that non-predictable factors have entered into the problem and caused the burst to miss the target; this condition can be overcome to some extent by the adjustment of fire.

Fire is adjusted in three dimensions, viz:

- (1) Range adjustment, along the line of position; usually made by an altitude correction.
- (2) Vertical adjustment, perpendicular to the line of position and in a vertical plane; made by means of an elevation correction.
- (3) Lateral adjustment, perpendicular to the line of position and in the inclined lateral plane; made by means of an azimuth correction.

In the application of the above, it is well to remember that altitude, vertical, and lateral corrections react independently. For example, a range correction in altitude, when fully assimilated in the director, will not affect either the vertical or lateral deviation; whereas, a range correction effected by a fuze spot will affect both the lateral and vertical deviations.

The methods of procedure in the adjustment of fire may vary in detail, according to the type of director. In this article an effort will be made to treat the subject broadly, considering all types of directors now in service. The study will be devoted primarily to the adjustment of fire against targets in rectilinear flight. It should be remembered that pilots find it difficult to fly any given course in an exactly straight flight; small deviations are bound to occur due to wind or other factors.

VERTICAL AND LATERAL ADJUSTMENT

The more prominent causes for lateral and vertical deviations are:

- (1) Small irregularities in the flight of the target, i.e., non-rectilinear flight.
- (2) Instrumental and personnel errors in predictions.
- (3) Errors in data transmission or in gun laying (frequently a small systematic lag of burst behind target)
- (4) Unknown wind effects.
- (5) Errors due to faulty orientation and faulty level.

Deviations due to causes (1) and (2) above will occur frequently, regardless of the care taken in the preparation of fire. Under certain conditions it is extremely difficult for a pilot to fly in a straight line, even when he wishes to do so; this is especially noticeable with towed targets, due to the effect of air currents. Errors in prediction can

and should be reduced to a minimum by the proper adjustment of the instruments and by the careful training of personnel. However, deviations due to both factors under consideration will occur and the methods to be used in adjustment should be based on such an expectation. A further analysis will show that the condition causing deviations may be a fleeting one, lasting only a few seconds; or it may continue throughout a course. It frequently happens that deviations occur, but by the time the bursts are seen the error already has been corrected automatically at its source. If meanwhile a spotting correction has been applied, it operates merely to duplicate the correction and thus will place the bursts on the other side of the target. At other times, conditions may be such that a fairly constant deviation in the bursts is manifested throughout the course, unless a correction is made. Experience shows that about one-half of the time such errors will correct themselves; therefore vertical and lateral corrections should be applied with caution.

The lag frequently experienced in data transmission can be reduced materially by training; however, the adjusting personnel should be alert to detect such effects. Often it is necessary to apply a small correction to lead the target; for example, a lateral correction to the right for a target on a left-to-right course, or a vertical correction up for an incoming target. When this condition is experienced, the vertical and lateral spotters should anticipate the required lag corrections on each course, and should apply such corrections before fire is opened.

When an accurate wind message is utilized with modern antiaircraft directors, the deviations due to unknown wind effects are small. Likewise when the guns are carefully oriented with the director, deviations from faulty orientation causes are avoided. If either the wind or the orientation factors are neglected, deviations from these causes may be expected to continue at a fairly constant value until the direction of fire is changed appreciably.

METHOD OF ADJUSTMENT

In general, the same rules apply both for lateral and for vertical adjustment. Corrections should be applied with caution, but continuously. In determining the value of the correction, the trace of the bursts, rather than the deviation of one salvo, should govern. The principle is illustrated in the figures which are drawn to represent the path of the target and the successive bursts on a course from left to right.

(Fig. 1). The bursts shown in the figures represent the burst centers for successive salvos. The first salvo (1), is ten mils above the target; the vertical spotter should immediately apply a down correction of one-half value (5 mils). When the second salvo (2) occurs with approximately the same deviation, the spotter should then in-

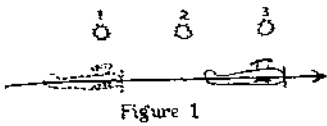

Figure 1

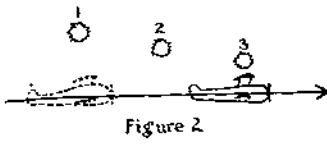

Figure 2

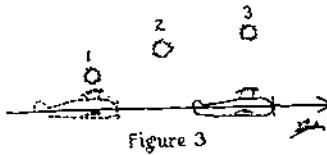

Figure 3

crease his correction to full value, or down 10 mils. When the third salvo occurs at the same vertical deviation, no correction is applied.

(Fig. 2). The first salvo (1) is ten mils above the target. The vertical spotter immediately applies a down correction of 5 mils, or one-half value. When the second salvo occurs with a smaller deviation,

he removes the correction, since it appears that the center of bursts is moving toward the target. No correction is made on the third salvo.

(Fig. 3). The first salvo (1) is ten mils high; the vertical spotter immediately applies a down correction of about 5 mils—one-half value. When the second salvo shows a greater vertical deviation, the correction is increased to full value—down about 12 mils. When the third salvo gives a still greater deviation, the correction is increased to something in excess of full value. In all cases the spotter watches continually the path of the bursts, and corrects accordingly. He should also note when the corrections previously made show up in the path of the bursts. However, antiaircraft targets will rarely be held under continual fire for more than thirty seconds; therefore the problem of applying corrections on top of corrections is less vital than when firing on naval targets.

SPOTTING

The spotter should apply his own corrections manually; therefore he should take position within convenient reach of the spotting handwheel. One spotter should perform the lateral adjustment, and another should make the vertical adjustment. Normally, enlisted men can perform these duties provided they have been selected carefully and are well trained for the purpose. The present tendency is toward observation by the unaided eye, rather than to depend upon telescopes with deflection scales. With proper training, spotters can acquire a surprising degree of accuracy in estimating deviations. In preliminary training, the spotters should be trained to estimate angles in mils by practicing on some improvised spotting device; several different types of these have been described in the JOURNAL. When firing is begun, spotters are tested and trained intensively on burst deviations.

Since the observers should observe the fire continuously, it is essential for them to be able to apply corrections without looking at the dials. This ability can be gained by learning the effect of one turn, or one-half turn, of the spotting handwheel, and by practice in the application of corrections. Some directors have clicking devices on the handwheel for this purpose. In observing, the spotter should not attempt to judge accurately the deviation of

each burst; it is preferable to visualize the path of the burst center. The effectiveness of the results will depend upon the prompt and proper exercise of good judgment, rather than upon extreme refinement in details.

RANGE ADJUSTMENT

The range adjustment constitutes the most important adjustment problem: frequently the range deviations are greater and more constant than are the other deviations. They are usually due to one of the following causes:

- (1) Inaccuracy in altitude determination.
- (2) Inaccuracy in fuze determination in the director, or in the fuze setting at the gun.

Inaccuracy in altitude determination is the main cause for such deviations; it always results in a range deviation greater than the defect in altitude measurement; at low elevations, the resultant range deviation may be two or three times as great as the altitude error itself. Frequently the range deviation is of such magnitude as to cause all of the bursts to be either "way over" or "way short"; in such cases, prompt and bold corrections are required.

In the study of such adjustments, it should be emphasized that they remain problems of *range adjustment*. Even though the correction may be made in terms of range, or of altitude, or of fuze, or of some other element, nevertheless the correction is a *range correction*, and it should be based on the range deviation along the line of position.

For example, in Figure 4 if the burst center is at any point along the curve 3-4-5, the correction should be the same as if the burst center were at 4. The vertical spotter will make a correction to bring the bursts to the line of position, and his correction will move the bursts in a line parallel to a fuze setter curve. The range correction, even though applied in terms of altitude, is the same for burst centers at 6 or 8. The deviations should be measured from 6 to 7, and from 8 to 9, respectively.

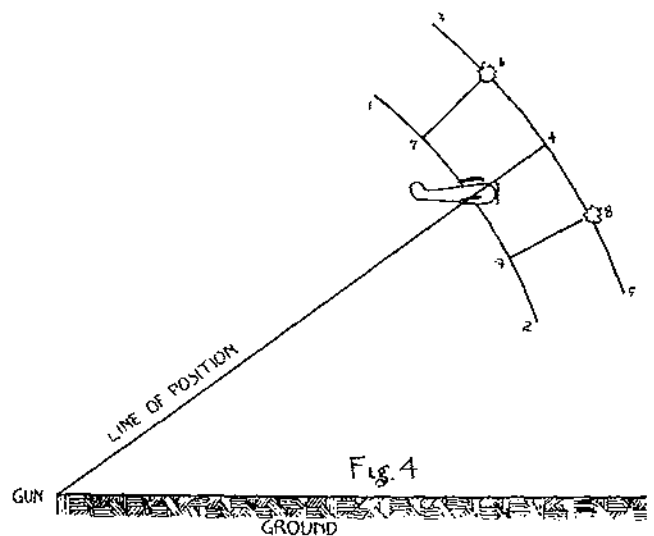

Fig. 4

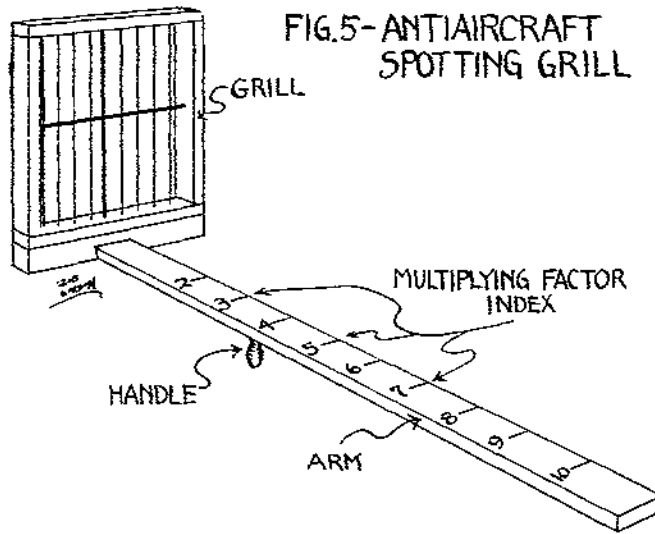

FIG.5- ANTI-AIRCRAFT SPOTTING GRILL

The following methods are outlined in the *Field Manual*:

Adjustment Method	Spotting Method
(1) Angular Unit.	Flank.
(2) Fuze Pattern.	Flank.
(3) Modified Bracketing.	Unilateral (Stereoscopic).

The following comments with reference to the several methods are based on personal experience, and are presented solely as the views of the writer.

The angular unit method, although slow in operation, gives satisfactory results in target practice. In a war-time set-up for a 360 degree field of fire, it would involve undue complication. When used in target practice, it is preferable to use a range rake to read the angular deviations along the line of position. The B.C. Instrument, M1, is not suitable for two main reasons, viz:

First, its limited field of view causes the bursts to be lost when the deviations are large, i.e., when the corrections are most badly needed.

Second, the deviations can not be read in the proper plane, i.e., along the line of position.

Also it is preferable to have the spotter report the deviation of the burst center, rather than the deviations of each burst, provided he has had sufficient training to make such reports with a reasonable degree of accuracy.

The fuze pattern method appears to offer a practicable solution. It does not provide refined accuracy but it is simple and suitable for any flank station. No instrument is required; no survey of the flank station is needed. This method has not been used extensively because primarily it is a four-gun-battery method, whereas in target practice only two guns are fired on a particular course.

The modified bracketing method, as applied in connection with stereoscopic spotting, depends entirely upon the ability of the observer to sense the bursts. Such sensing can be achieved only by intensive training; even then effective spotting is very difficult; consequently, corrections based upon stereoscopic spotting should be applied with caution. The chief reliance should be placed upon accurate altitude determination; hence the necessity for the con-

tinuous training of the observers, and for care in the instrumental adjustment of the height finders.

There is an urgent need in the anti-aircraft service for the development of a simple spotting method suitable for use at flank stations located within 2,500 yards of the battery. The system should not be dependent upon accurate survey of such stations, nor upon the supply of delicate and expensive instruments. The altitude method offers considerable promise of fulfilling these requirements. It was developed and tested during the Aberdeen Proving Ground Antiaircraft Exercises, and has since been used satisfactorily by a few batteries. This method requires the employment of an intelligent and well trained spotter, upon whom the responsibility for range spotting rests. He estimates the range deviations directly in terms of altitude. From a practical point of view two methods of altitude spotting give considerable promise.

With the first method, an altitude spotting grill, or a modified range rake, is used (Figure 5). The grill is used to measure the range deviation in terms of altitude through the application of the angular unit principle. The vertical wires are spaced one-half inch apart; the center vertical wire and the center horizontal wire are slightly larger in diameter to denote the center of the grill. In operation, the grill is tilted so as to place the horizontal wire along the line of position. The range deviations are then measured along, or parallel to, that line. With the eye at a point along the arm twenty inches from the grill, the lateral angle between two adjacent vertical wires is, by construction, 25 mils. It is desirable to have the range deviation between two vertical wires represent a value equivalent to 100 yards in altitude; therefore the multiplying factor that is automatically applied when the spotter's eye is twenty inches from the grill is $100/25$, or 4.

On this basis, the multiplying factor graduations are then marked on the arm as follows:

Multiplying Factor	Distance from Grill
2	10 inches
3	15 "
4	20 "
5	25 "
6	30 "
7	35 "
8	40 "
9	45 "
10	50 "

Usually only two or three different multiplying factors are required in order to cover the entire field of fire. In a firing position where the flank station is forward and at a distance of 4,000 yards on the right flank, the multiplying factors for firings at medium ranges and at altitudes of about 3,000 yards are:

Right field of fire	3
Center field of fire	4
Left field of fire	6

A practical solution is to mark each of the three desired points on the arm of the spotting grill by heavy rubber

bands. The spotter holds the instrument with his right hand on the handle and the instrument arm extending to the rear over his right shoulder. When the target is in the right field of fire (close to him), he pulls the grill toward his eye until his chin strikes the rubber band nearest the grill. When the target is in the center field of fire, he moves the grill to place his chin against the center rubber band. When the target is in the left field of fire, he moves the grill until his chin strikes the rubber band farthest from the grill. When firing is opened, he spots the burst center in sense, and calls out the required correction in direction to the nearest ten yards of altitude.

In order that the burst center may be placed about 25 yards short of the target, the spotter is trained to hold his center vertical wire just short of the target; an allowance equal to the width of the wire is sufficient. In this connection, it is well to remember that the camera locates the burst a few yards short of the burst center as seen by the spotter, since the camera detects the explosion more quickly than the eye. Target practice records indicate that the usual tendency in range adjustment is to place the burst center too short.

For each situation the multiplying factors should be determined, and the spotters should be instructed in their application prior to fire. The mathematical expression for the multiplying factor at a given point is:

$$\text{Factor} = \frac{D_r \sin E}{\sin I}$$

$$\text{Where } D_r = \frac{\text{Slant distance (Observer to target) in yds.}}{1000}$$

E = Angular height of target from guns.

I = Angle at target between the lines, gun—target and observer—target. The distance of the target from the observer, and its altitude are the controlling factors. The angle "I" is not a rapidly changing variable. (Reference: Par. 78 c. C.A. F.M., Vol. II.)

From the foregoing, it is apparent that the method outlined is merely a modification of the angular unit method now in use. The main point of difference is that the spotter applies the multiplying factor by positioning his eye with respect to the grill; whereas in the older method the range officer applied the factor arithmetically. A second point of difference is that the spotter spots the burst center instead of each separate burst. Both changes are made in an effort to gain simplicity in speed. The range officer usually is taxed with supervising the work of the range section, and particularly with the altitude setting. For him to attempt to strike averages and to apply multiplying factors results in too much delay. The flank spotter has only the spotting task to perform; he is located in a better position to apply the multiplying factor; and when two or more guns are firing, the burst center stands out clearly without any arithmetical computation.

The second method is merely a variation of the first. The spotter uses the altitude spotting grill as a training instrument, and eventually trains himself to spot by eye

in terms of altitude. His final training comes from actual spotting during preliminary firings. From two to four rounds are fired at the towed target, and he spots the altitude deviation of the burst center. An altitude correction is applied exactly according to his spot, and fire is again opened on the same course in order that he may observe its effect. Eventually he will have observed the effects of his spotting corrections and in this practical manner he develops his own yard-stick. If adept, he can soon learn to estimate deviations with satisfactory accuracy. He should then make his spots to the nearest ten yards.

The spotter should be connected to the range adjustment officer by telephone. He can spot the sensing of each burst until enough bursts have occurred to permit him to locate the burst center. He then announces the correction in yards of altitude. For example, as the bursts begin to occur he calls out clearly, "Over," "Over," "Down One Hundred Yards," or "Short," "Short," "Short," "Up Forty Yards." If the bursts are far short or far over, he calls out a correction after the first salvo. If the bursts are close to the target, and if the fire is continuous, he calls only the sensings until at least four bursts occur; then he calls out the correction in yards of altitude, if any correction is required. He should repeat the correction once, and by that time the range adjusting officer should indicate to the spotter that the correction is in; thereafter he spots sensings only for each salvo. Good teamwork between the spotter and the adjusting officer should be developed. Additional corrections to modify the first correction may then be made on a course. Sometimes after a correction is applied on the first salvo, the following salvos will indicate a need for a change in the correction. In this case the spotting might be made as follows: "Over," "Over," "Down Eighty Yards—Down Eighty Yards," "Still Over," "Way Over," "Down Forty Yards—Down Forty Yards," "Over," "Okay," "Okay." In this example, the spotter finally called for a total correction of down 120 yards; as the first correction showed up in the burst, he indicated that no further correction was required. He should continue spotting until the shoot is over. He should be trained to give a few burst center spots clearly, rather than to attempt to spot each burst. Too many reports operate to confuse the adjusting officer.

Some officers prefer to have spotters report burst center deviations only, reserving to the range officer the decision as to the correction. The writer prefers the former scheme, since he believes that the spotter will make the decision more promptly, and will also learn his job better, when he knows exactly what corrections are applied on each course. The latter scheme is now being used satisfactorily in several batteries. With either scheme the principal objectives are simplicity and speed.

METHOD OF ADJUSTMENT

When the spotting is made as outlined in the preceding paragraph, the adjusting officer should correct the fire

exactly as directed by the spotter. Upon the completion of the course, he makes a record of the corrections applied and then analyzes the course to determine the total corrections needed. He then determines the correction to carry forward to the next course. Normally, corrections from course to course are made as flat altitude corrections on the director. In determining its value, all factors should be considered. Possibly the full value of the final corrections on the first course should be carried forward to course two. If the opportunities for altitude determination on the first course were poor, the correction made may be reduced to a fraction. If the target maneuvered extensively, the course correction may be entirely disregarded. After course two, or subsequent courses, the correction to be carried forward should be changed by not more than one-half of the net spotting correction made on that course, as illustrated in the following example:

COURSE TO COURSE CORRECTIONS

Course	Initial Correction	Course Spotting Correction	Correction Forward
1	0	-100	-100
2	-100	+ 60	- 70
3	- 70	- 40	- 90
4	- 90	+ 20	- 80

ADJUSTMENT OF FIRE AGAINST MANEUVERING TARGET

The subject is treated extensively in Par. 79, C.A.F.M. In this study only a few main points are covered.

When the target begins to maneuver, it is practically useless to pay any attention to the vertical and lateral deviations of bursts. A smart pilot will engage in one maneuver for a period about equal to the time of flight, and then he is likely to begin a maneuver exactly the opposite. For example, if the bursts begin to lead the target appreciably, it indicates that a few seconds earlier the pilot decreased his speed. By the time this becomes apparent he may be increasing his speed; if so, the corrections called for by the deviations will be exactly the reverse of those required. In order to spot fire successfully on a maneuvering target, it is necessary to anticipate what the pilot is going to do and to apply the correction as soon as (or before) he does it. The plane should be watched closely. If the pilot tips the nose of the plane down, he indicates

a dive and the chances are that he will also increase the motor's speed; a lateral correction ahead, a vertical correction down, and an altitude correction down are then dictated. Now, as the dive is continued, the director gradually picks it up and, therefore, the necessity for the vertical and lateral maneuvering spots disappears and they should gradually be taken out before the dive is completed. The altitude should be decreased continually until the pilot begins to level off. The spotters should keep their hands on the handwheel, because ordinarily they have to change the spots continuously. They should be trained to apply automatically the corrections for a few typical maneuvers. Corrections to offset maneuver should be applied promptly and boldly; likewise, they should be removed quickly.

GLIDING TARGETS

We are taught to expect enemy bombardment aviation to approach at high altitudes; to enter an antiaircraft gun area in a moderate glide; and to continue such a glide until within about thirty seconds of the bomb-release point. Such flight presents a problem more difficult than is apparent upon first glance. Obviously an accurate and continuous altimetric system is needed, in order that the future altitude may be set accurately and continuously. With the present altimetric equipment, it is necessary to estimate the rate of change and to apply roughly the predicted value. When the modern angular travel directors are used, they can be relied upon to pick up the angular rates with fair accuracy provided the future altitudes are applied. With the "plan prediction" type of instruments, the changing present altitude should be set continuously; also the future altitude spot should be applied for the change during the time of flight. The method of procedure recommended for diving targets by the manufacturers of the Sperry directors—that of matching angular height by means of the altitude handwheel—will give satisfactory results only for a short glide, and even then only when the range rates are well established before the glide is begun. On a long glide it leads to highly erratic results. With all of the present directors, it is the sounder principle to continue to use altitude as the basic element of measured range data.

IT IS IMPOSSIBLE for nations to accept internationalism at the expense of nationalism because the policies of too many countries do not admit of compromise, and each tries to inflict his own interested point of view on the others.—CAPTAIN A. T. BEAUREGARD, U. S. NAVY.

TROPHIES

THE September-October, 1935 issue of the COAST ARTILLERY JOURNAL carried an announcement of a new method for determining the winner of the Coast Artillery Association trophy awarded annually to a reserve regiment. This plan was evolved after long study and much painstaking effort on the part of a committee appointed by the President of the Association. The formula is designed to encourage each member of the regiment to complete at least forty hours of extension school work during the year and to minimize the effect on the regimental standing of the prodigious work performed by a few energetic officers, thus raising the regimental average while other members do little or nothing. Whether or not the plan fully accomplishes the desired object remains to be determined. However, it is apparent that no matter what scheme is evolved those regiments that have shown superior performance in the past are again in the vanguard. This leads to the conclusion that interest, industry and perseverance will win out in any competition regardless of the rules. It is believed that the present scheme possesses some advantages over the one previously employed; perhaps after further trial a better plan can be devised.

THE WINNER

It is the pleasure and privilege of the JOURNAL to announce that the winner for the school year ending June 30, 1936, is the 57th C.A. (TD). The personnel of this regiment is located principally in Northern California. The Regimental Commander is Lieut. Col. W. W. Breite, and the unit instructor is Lieut. Col. Albert L. Loustalot. Just why the majority of the trophies go to California remains a mystery. Several times the JOURNAL has intimated that an explanation of this would be of interest but so far our angling has produced no results. Will not someone in close touch with the situation favor the JOURNAL and its readers with the answer?

By a strange coincidence the average monthly strength of the 57th was 57 (perhaps this is a magical number). The total number of credit hours earned was 3,173, an

average of 55.66 hours per individual (too bad it could not have been 57). Forty-six members of the regiment (nearly 81%) earned 40 or more credit hours each; truly a remarkable showing. The 57th was in fourth place in last year's competition, therefore the winning of the trophy this year is not the result of sporadic effort. It shows consistency, perseverance and professional zeal; qualities which are sure to win recognition.

The JOURNAL *desires* to congratulate Colonel Breite and the entire personnel of the 57th. The record speaks for itself. It is the culmination of much painstaking work and effort unaccompanied by the plaudits of the public. No cheers for those who labor in the seclusion of their private studies, or those who spend long hours poring over maps on the dining-room table or in the humbler kitchen. No immediate glory to those who struggle assiduously to prepare themselves for the duties and obligations which they must shoulder if and when the drums roll and the call to arms sounds throughout the land. But a very tangible result accrues to the individual in the form of increased knowledge and a better understanding of the duties and obligations of citizenship.

In announcing second honors we cannot avoid injecting a note of sympathy; not that any sympathy is needed because the record carries with it more honor and glory than normally falls to the lot of one organization. There is an old saw to the effect that sometimes there is more glory in defeat than in victory. If this be true then the 507th C.A. (AA) has all the glory that could possibly attend a victor. It will be recalled that this organization stood second in the 1933 competition; was the winner in the 1934 race; stood second by .3 of one point in the 1935 contest, and this year is separated from the winning regiment by .097. Three seconds and one first out of four starts is a record in which any organization should take justifiable pride. (No, this is not a play on words.) To Lieut. Col. H. E. Pride, the Regimental Commander and to Major B. L. Flanigen, the unit instructor, go both congratulations and condolences. They did not lose heart or give up the struggle after the 1933 and the 1935 con-

STANDING OF THE CORPS AREAS

Corps Area	No. Units	Average Strength Per Unit	Total Number Credit Hours	Average Number Credit Hours Per Unit	Average Number Credit Hours Per Ind.	Relative Standing of Corps Areas (sum of regimental ratings divided by number of units).
First	14	42	12,969	926	22	27.6
Second	14	50	14,563	1,040	21	32.4
Third	12	80	26,144	2,179	28	38.5
Fourth	9	123	14,356	1,595	13	18.2
Fifth	8	53	7,113	889	17	23.6
Sixth	9	60	7,657	851	14	21.9
Seventh	8	96	16,202	2,025	21	39.7
Eighth	5	46	5,525	1,105	24	36.2
Ninth	16	55	33,888	2,118	39	58.3

rest, and they will not become discouraged by again placing second. The personnel of the regiment has manifested determination and perseverance to a marked degree. In 1934 this regiment established the hitherto unheard of score of 135.96 credit hours per member, a record unequalled to date and one which we predict will remain unsurpassed for many years.

For third honors a new-comer appears in the constellation—none other than the 974th C.A. (AA) whose personnel hails from the great State of Texas. This unit, under the command of Major Ellsworth Guy and the tutelage of Major R. E. Phillips, C.A.C., will have to be reckoned with as a serious contender for high honors in future competition.

In 1935 seven out of the first ten places in relative standing went to units in the IX Corps Area. This year five out of the first ten were garnered by units located on the Pacific seaboard. The following tabulations tell the story better than a word picture. We regret that space does not permit listing all units.

STANDING OF THE FIRST TEN REGIMENTS

	Regt.	Average Strength	Total Number Credit Hours	Score	Corps Area
1.	57	57	3,173	94.238	IX
2.	507	52	2,930	94.141	VII
3.	974	52	2,476	87.589	VIII
4.	627	72	3,779	87.514	IX
5.	977	71	3,574	85.145	IX
6.	523	83	4,137	71.	III
7.	509	65	2,780	73.	IX
8.	630	65	2,890	70.	IX
9.	960	69	3,208	69.	VII
10.	508	108	5,180	68.	III

In announcing the winner the President of the U. S. Coast Artillery Association, Major General A. H. Sunderland, addressed the following letter to Lieut. Col. W. W. Breite, 57th C.A. (TD):

Dear Colonel Breite:

I take great pleasure in informing you that the Executive Council of the U. S. Coast Artillery Association has designated the 57th C.A. (TD) as the winner of the trophy awarded annually to a regiment of the Organized Reserves for outstanding performance in extension school work. This signal honor is positive proof that the members of your regiment have devoted many hours of their time to study to the end that they may be better prepared to perform the duties which they will be called upon to perform in the event of mobilization.

For this outstanding and meritorious performance I desire to extend to you, and through you to all members of the regiment, my personal congratulations and the best wishes of the Coast Artillery Association.

The Secretary has been instructed to order the trophy and you will be informed when it is ready for delivery.

Truly,

A. H. SUNDERLAND,
Major General, President.

THE FOLLOWING TABLES SHOW THE STANDING OF THE FIRST THREE REGIMENTS IN EACH CORPS AREA:

Unit	FIRST C.A.	Score
542		54.
615		42.
903		39.
	SECOND C.A.	
514		58.
513		49.
620		40.
	THIRD C.A.	
523		71.
508		68.
503		66.
	FOURTH C.A.	
623		28.
545		24.
504		23.
	FIFTH C.A.	
535		42.
932		35.
938		28.
	SIXTH C.A.	
950		36.
526		35.
536		34.
	SEVENTH C.A.	
507		94.141
960		69.
527		36.
	EIGHTH C.A.	
974		87.589
973		41.
969		25.
	NINTH C.A.	
57		94.238
627		87.514
977		85.145
509		73.
630		70.

The Individual Trophy

THE policy adopted by the Coast Artillery Association in 1933—the award of a suitable memento to the Reserve officer in each Corps Area who accumulates the greatest number of credit hours by means of completed extension school work—will be continued this year. Reports indicate that the award of this trophy has created considerable interest and has been the means of stimulating individual effort.

For the fourth consecutive time the individual high score goes to an officer residing in California. Apparently everything in that state is done on a grand scale. For a long time we have earnestly sought for a reasonable explanation as to why this is true but the answer, like the fourth dimension, remains a mystery. This time the individual high scorer is Lieutenant Eugene M. Graham, 6th C.A. While his record is somewhat lower than the all-time high score established in 1935 by Lieutenant Harold I. Strahn of the 975th C.A. (AA), nevertheless Lieut. Graham's record has reached a height others will find difficulty in

scaling. His record is 39 completed subcourses, representing a total of 744 credit hours.

The accompanying tabulation tells all the story. The Executive Council of the Association, and the JOURNAL extend to each officer sincere congratulations for outstanding and meritorious performance. To each, the President of the Association, Major General A. H. Sunderland, has addressed the following letter:

"My dear . . .

The Coast Artillery Association awards annually a saber to the Coast Artillery Reserve officer in each Corps Area who accumulates the greatest number of credit hours by means of completed extension school work.

It gives me great pleasure to advise that you have been designated the winner of this trophy in the . . . Corps

Area. I congratulate you for this manifestation of interest in reserve corps activities and your devotion to the cause of preparedness. In doing this I am mindful of the fact that you could not have been the recipient of this signal honor without long hours of study, perhaps at the sacrifice of what otherwise would have been your leisure time; for this I cannot too strongly commend you; your fine work will be an example and incentive to others.

The saber will be forwarded to you by the Secretary of the Association in due time.

Truly,

A. H. SUNDERLAND,
Major General,
President."

Corps Area	Name	Organization	Address	No. Subcourses	No. Lessons	No. Hours
First	Capt. Edwin A. Goodwin	542d C.A.	127 High Street, Somersworth, N. H.	10	78	229
Second	1st Lt. William M. Barrows	513th C.A.	99 Genesee Street, Rochester, N. Y.	13	110	281
Third	1st Lt. Harry A. Edwards	508th C.A.	2528 Homehurst Avenue, Pittsburgh, Pa.	17	139	366
Fourth	Capt. George R. Clemens	545th C.A.	Miss. River Commission, Vicksburg, Miss.	9	60	212
Fifth	2d Lt. James W. Seltzer, Jr.	938th C.A.	2421 Ashland Avenue, Cincinnati, Ohio	6	75	202
Sixth	1st Lt. John D. Flewelling	526th C.A.	312 Mary Street, Union City, Michigan	5	78	255
Seventh	Capt. Melford M. Lothrop	507th C.A.	3636 Pierce Street, Sioux City, Iowa	6	49	450
Eighth	2d Lt. Charles L. Schliecker	974th C.A.	1926 Hanover Street, Aurora, Colorado	15	119	347
Ninth	1st Lt. Eugene M. Graham	6th C.A.	1249 Pine Street, San Francisco, Calif.	39	258	744

Meeting of the U. S. Coast Artillery Association

THE third meeting of the U. S. Coast Artillery Association was held at Fort Monroe, Virginia, August 21-23, 1936. When the Executive Council decided to hold this meeting the field was canvassed to determine the most suitable place. It was thought to be logical and proper to select Fort Monroe, the fountain-head of Coast Artillery Corps activities, where the majority of the different classes of matériel and equipment could be demonstrated and examined; also the Coast Artillery School is located there with its model shops, laboratories, garages and much experimental equipment.

Aside from its technical and professional aspects Fort Monroe has a strong attraction for a large number of Coast Artillerymen. Most regular officers, above the grade of second lieutenant, have served one or more tours at this post, while to many members of the civilian components the mention of Fort Monroe brings up memories of training periods dating back to the hectic days of 1917 and continuing through the calmer post-war periods. To many a visit to Fort Monroe is looked upon as a pleasant outing, spent in a congenial atmosphere, where instruction sometimes is combined with pleasure.

The Commanding Officer, General Joseph P. Tracy, his staff and the entire garrison spared no effort to make the meeting a success and one long to be remembered

by those who attended. To these resident officers great credit is due and the members of the Association are deeply indebted to them for the painstaking arrangements, both professional and social, which so greatly contributed to the instruction and entertainment of the visiting members and their families.

The show opened on Friday, August 21, with approximately 140 visiting officers in attendance. The first act was put on by the Commanding Officer, Submarine Mine Depot; this consisted of detonating a mine, inspecting the depot and matériel. The mine system functioned perfectly, with a slight delay due to the fact that the demonstration was a test of experimental matériel.

The next act was staged under the direction of the Coast Artillery Board. This consisted of putting a high speed motor boat through its paces without any personnel on board. The boat, designed as a target for seacoast armament, responded to radio messages sent from a control station on a harbor boat. This demonstration was of great interest to those not familiar with this adaptation of remote control by radio.

Following this the visiting officers were taken on a tour of inspection of the Coast Artillery School, its laboratories and shops. The afternoon was given over to demonstration firings by 155-mm. guns by "B" Battery, 51st Coast Artillery, Captain Wm. F. Niethamer, com-

manding; antiaircraft guns and machine guns by "C" Battery, 2d Coast Artillery, Captain A. M. Wilson, commanding. The firings were conducted with precision which indicated the excellent state of training of these organizations. The most spectacular feature of this demonstration occurred when the towed antiaircraft target was brought down with almost the last round of available ammunition. This concluded the demonstration of the weapons employed by the Coast Artillery in carrying out their mission of the attack of enemy naval vessels by means of artillery fire and submarine mines and the attack of enemy aircraft by means of fire from the ground. The preliminary air attack had been repulsed, the cruiser and destroyer raiders had been driven off and the attempted run-by had run afoul of the submarine mines. With a feeling of security the visiting officers and others assembled at the Officers' Beach Club where light refreshments helped to relieve the discomfort of an unusually hot afternoon.

The next act was a review and parade by the troops of the regular garrison. Major General Sunderland received the review accompanied by a large staff of visiting officers. The following troops participated: 2d Coast Artillery, commanded by Lieutenant Colonel F. S. Clark, 51st Coast Artillery, commanded by Lieutenant Colonel E. B. Walker, and the 52d Coast Artillery, commanded by Lieutenant Colonel F. A. Price. The troops presented a magnificent appearance and elicited favorable comment for their soldierly bearing and precision. This concluded the day's military activities. In the evening a reception and dance in honor of the visiting members was held at the Officers' Beach Club. In the receiving line were General and Mrs. Sunderland, General and Mrs. Tracy, Colonel E. A. Wood of the Virginia National Guard and Colonel C. H. Scheer, C.A.-Res.

On Saturday morning the 246th Virginia National Guard, commanded by Colonel E. A. Wood, held a review followed by a field inspection. Later there was a short business meeting of the Association at which General Sunderland presided. General Tracy welcomed the Association to Fort Monroe and expressed the hope that all visiting members would want to come again. He stated that the garrison at Monroe was always anxious to show its wares and emphasized the importance of the Coast Artillery School and the Coast Artillery Board in the development of matériel, tactics and technique. He pointed out that the activities at Fort Monroe were divided into two main categories; first, the Third Coast Artillery District and the Harbor Defenses, functioning under the Corps Area Commander; second, the Coast Artillery School, the Coast Artillery Board and the Submarine Mine Depot functioning under the direction of the Chief of Coast Artillery. General Tracy thanked the Association for selecting Fort Monroe as the scene of its meeting and hoped that the short stay was both beneficial and enjoyable.

General Sunderland thanked General Tracy and the entire garrison for their efforts which contributed so much to the success of the meeting and stated that a better place could not have been selected. He then outlined the purpose and object of the Association, explaining that it draws its membership from the three components of the Army. Assemblies of this nature afford an excellent opportunity for officers to meet on a common ground and discuss the problems vital to the Coast Artillery in national defense. He expressed the hope that a plan might be evolved whereby the members of the Association could get together more frequently. Aside from the instructional value personal contacts are sure to be beneficial and weld the ties of good fellowship. General Sunderland pointed out that in the event of a major mobilization the Regular Army, as such, will disappear; most of its personnel will be engaged on staff duty or used for the training of the National Army. This means that the National Guard will be called upon to bear the brunt of the fighting until the newly created levies are ready to take the field; therefore, to the Reserve Officers will fall most of the duty of equipping and training new units. In concluding his remarks General Sunderland stated:

"The membership of the Association, which now numbers approximately 5,500, can be reached only through the medium of the COAST ARTILLERY JOURNAL. This is one of my responsibilities and I will exert every effort to make the JOURNAL worth reading. I hope that all members will support the Association by means of a subscription."

Saturday afternoon was given over to recreation and amusement. In the evening a banquet was held at the Officers' Beach Club with 125 in attendance. General Sunderland acted as toastmaster; brief remarks were made by General Tracy, Colonel J. B. Bennett, CA-Res., Colonel E. W. Thomson, CA-Res. and Lieutenant Colonel W. J. Hislop of the 212th New York National Guard.

The attendance, though not as large as had been hoped for, was considered satisfactory considering the fact that the time of the meeting conflicted with the training activities of a number of National Guard and Reserve regiments. Many expressions of approval lead to the conclusion that all were amply repaid for the time and trouble. It is hoped that these meetings will become regular events.

In this connection we are wondering if it could not be arranged to have a meeting on the Pacific Coast, where a mutual understanding and cooperation of all Coast Artillerymen is equally essential to our national defense. The officers in the far west have demonstrated many times, and in many ways, their interest in Coast Artillery activities and can always be depended upon to put over, in a big way, any project they undertake. This is merely a suggestion, we hope it falls as a seed on fertile soil.

The Backbone of the Army

By MAJOR JOSHUA D. POWERS, C.A.C.

THE backbone of the army is the noncommissioned officer." A familiar quotation, but is our system of army training and education designed to develop and strengthen the backbone? We realize that officers and the specialist NCO's cannot be trained within the regiment, for these we have established schools to which they are sent to learn the fundamental of our profession. Even recruits are organized into recruit detachments where they are given the basic training of the soldier. But the line Noncom, who comes between the technically trained officer and the private, and who is the bottle neck through which our instruction must pass, just picks up his military education, if, when, where and how he can.

In too many batteries the situation is something like this: Captain Thomason has two sergeants retiring. He decides to promote the two senior corporals. Then he calls in the first sergeant and asks: "Who will we make corporals?" The sergeant answers: "Skezinski has been an acting corporal for six months. His drill isn't so hot, but he's dependable and he does know tractors. Then there is Thornton, he hasn't much service, but he is smart and he takes an interest. The old soldiers will crab at having him promoted over them, but it may snap them out of their dope." The captain says: "Neither of them is too good, but give them a chance. If they do not turn out well we can always make them sergeants and send them on foreign service." So a day or two later their warrants arrive and according to the regimental training policies they are now required to:

- Command, instruct, and supervise a squad.
- Know all the duties of corporal of the guard.
- Know how to drill a platoon.
- Know the duties of a GPF gun commander.
- Know the drill of the range section.
- Know all about gas defense and gas discipline.
- Know the regulations pertaining to riot duty.
- Know first aid.
- Be a leader in athletics.

Skezinski got as far as the third grade quite some time ago. He had an enlistment in a machine gun company, and has now been in the battery for eight years. He can drill, but usually has some urgent work on a tractor when the battery falls in for drill. During target practice he helps the ordnance machinist. He keeps his mouth shut and if sent out with a detail gets the work done by the simple process of doing half of it himself. He has never acted as an instructor.

Thornton has been through high school, had one year in college. Has been in the battery two years. Quick to learn from books. Apt to be bothered by the kidding of the old soldiers. Still a little nervous at target practice.

No mechanical sense—confuses "cycles" with "cylinders" and can never understand a "variable recoil."

Captain Thomason now has two corporals who are two more vertebrae in the well known "backbone." The captain makes a mental resolution to give them some training; but summer camps come along, then his own target practice, then the garrison inspection, then armament inspection, and when gunners' instruction time arrives all the men are on guard or fatigue. It looks like there never is a time when he can get his noncoms together for a little training.

When Captain Thomason leaves the battery and Captain Ogden takes over, there are other corporals junior to Skezinski and Thornton. Captain Ogden hears they have been corporals for a year or so, assumes they know their job, figures he can depend on them; and starts in to check the 462 different gadgets for which a GPF battery commander must sign.

This word picture may seem a little overdrawn. I believe that there is a simple solution. The idea is not original with me and has worked well in the past. Today a sergeant who is my right hand man gives credit to a NONCOMMISSIONED OFFICERS TRAINING SCHOOL that he attended.

I would organize such a school in each regiment, or in a larger command if several regiments are serving at the same post. Once each year the school would function for two months. An officer and the necessary assistants would be put on full time duty with the school.

The students would be organized as a detachment, this would be composed of men whom the battery commanders believe to be NCO material and such NCO's as need the instruction. There would be no published grades and no failures. Each man completing the course would be given a certificate. If the work were properly presented, there is no question about men taking an interest. If a man was obviously a misfit or getting nothing out of the school, he would be relieved at once.

The following is a suggested program for such a school, I realize that this would have to be modified to suit local conditions. Experience will suggest many changes. It is a "trial balloon" sent up with the idea of drawing fire and stimulating interest in the training of Noncommissioned officers:

PROGRAM

Eight weeks, each of 29 instruction hours [A.M., 8:00 to 11:30; P.M., (except Wednesdays and Saturdays) 1:00 to 3:00. Sundays free]

SUBJECT	HOURS
Military history	20
Tactics of the type of armament assigned to the regiment	8

SUBJECT	HOURS	SUBJECT	HOURS
War Plans and Mobilization concerned, and such of the regiment	6	First Aid	8
Reconnaissance of areas in which the regiment is likely to operate (4 Wednesday afternoons)	6	Riot Duty: emphasizing duties and responsibilities of the NCO	6
Training Regulations: what they are and how to find subjects in them	2	Drill of gun section on one type of gun: emphasizing duties of gun commander	10
Army Regulations: what they are and how to find subjects in them	2	Drill of range section	32
Army paper work; practical examples	6	The pistol	4
Sketching and map reading	18	The automatic rifle	8
Motor vehicles: inspection and convoy regulations	4	The machine gun	8
Close order drill; emphasizing duties of the instructor	38	The rifle; particularly emphasizing duties of instructor in preliminary training and in range firing	16
Extended order drill; emphasizing duties of the instructor	8	Athletics (Afternoons after classes)	16
Chemical Warfare Defense	12	Inspections, including care and marking of clothing and equipment	16
		Total	232

The Advanced Course Student

BY MAJOR FRANK J. PEARSON, *Infantry*

ALTHOUGH 212 colleges are now offering Senior ROTC instruction, it is not likely that any two units in those schools function under identical schedules. They may conform to the principles laid down in the very elastic War Department directive, but that is a different matter.

Now every unit, regardless of local conditions, has certain similar and fundamental problems. The selection of well qualified Advanced Course students is one.

In this regard, the method of selection used by one of our large universities on the West Coast has been found highly satisfactory in securing excellent officer material. At this school, which boasts some 1,300 cadets, the authorized Advanced Course enrollment is limited to 150. The college operates on a two-semester calendar. There are six Regular Army officers detailed, including the PMS&T. For drill purposes the corps is divided into three battalions, each of which has a separate drill period. Thus, each company can be supervised by a Regular officer who has an excellent opportunity to observe the work of each individual.

After the semester has been under way for about a month, a notice is published advising all prospective candidates for the Advanced Course to secure and wear a small blue button on the flap of the upper left pocket. A student is thus identified as an Advanced Course candidate and becomes a "marked" man, realizing, moreover, that he is being observed.

About a month before the semester ends, these students get an application form from headquarters. This form gives the student's military record, including previous Junior or other military training, his basic grades, his grade within his company, campus activities, recommendations of those who know him, and other pertinent data that would aid a board of officers to determine his fitness for selection.

Just prior to the completion of the semester, each applicant appears in uniform before a board composed of

the Regular officers with the unit. The recorder reads off the data on the application form. Each member of the board, without consultation with the others, then rates the student on his military bearing and neatness, on the general impression he creates, and on his recommendations. The weight assigned to the military bearing is a possible 15, and his recommendations count likewise. These ratings, of course, are flexible. All other qualifications have set values as follows:

Previous 55c training, rank of major or above	4
rank as captain	3
rank as lieutenant	2
rank as NCO	1
Basic grades, average of A	4
average of B	3
average of C	2
average of D	1
Number of semesters in college, for each semester	1
NCO grade within the Corps: sergeant	4
corporal	2
private, first class	1

On this basis ratings are computed and a relative rank list is published showing final standings.

To take care of those who may drop out or those who fail to return from the already enrolled Advanced students, about ten extra applicants take the physical examination. This examination is given before the end of the semester so that the new class of those physically fit can begin the new semester without delay. When a student is disqualified, the student next on the list moves up.

This method, permitting a long thorough opportunity to observe the work of each individual, has resulted in the selection of outstanding men of the unit and campus for the Advanced Course. A fair determination of the student's value is reached, and what is equally desirable, the students themselves feel that the final selection is just and fair. The method also creates a high interest on the campus. Since it has been used there has never been a semester in which there have not been twice as many applicants as could be accepted.

NEWS AND COMMENT

The United States Coast Artillery Association



"The purpose of the Association shall be to promote the efficiency of the Coast Artillery Corps by maintaining its standards and traditions, by disseminating professional knowledge, by inspiring greater effort towards the improvement of matériel and methods of training, and by fostering mutual understanding, respect and coöperation among all arms, branches and components of the Regular Army, National Guard, Organized Reserve and Reserve Officers' Training Corps."

OFFICERS

President

MAJOR GENERAL A. H. SUNDERLAND

Vice-President

COLONEL F. H. LINCOLN

Secretary-Treasurer

LIEUT. COL. E. E. BENNETT

Additional Members of the Executive Council

BRIG. GEN. J. J. BYRNE

LT. COL. C. M. IRWIN

LT. COL. SANDERFORD JARMAN

LT. COL. H. E. PRIDE

LT. COL. R. S. ATWOOD

MAJOR LEROY LUTES

MAJOR JOHN CASWELL

Activities of Association Chapters

POSSIBLY it may be of assistance and benefit to the heads of Chapters to know what some of their sister organizations are doing by way of developing *esprit de corps* and interest in Association activities. Although a number of reports have reached this office no useful purpose will be served by reproducing them in their entirety, however we feel sure that pertinent extracts will be of value.

From the Duluth Chapter comes the information that the primary objective has been to encourage Coast Artillery officers to complete the inactive duty requirements of their grade in order to prepare for the two weeks active duty training and to further encourage them to support the National Defense policies. A plan is under way to make representation to the War Department urging the establishment of a regular army antiaircraft regiment

within the Seventh Corps Area so that Coast Artillery Reserve officers residing therein might receive better training and instruction. This project has considerable merit.

The Houston Chapter is very much alive and has plans for doing things in a big way. This is one of the chapters that charges membership dues. Meetings are held the first Monday of each month from October to June. These meetings consist of a dinner at one of the hotels and later proceeding to the regular monthly meeting of the Reserve Officers' Association. Socially the chapter is very active. It holds two dances each year and one stag party. The attendance at stated meetings has been most gratifying. As a rule no outside guests are invited, the single exception to this being the commanding officer of the 69th C.A. (AA) from Fort Crockett, Texas. Among the numerous extraneous activities carried on by the Chapter is that of recruiting for the 69th C.A. (AA) and assisting in the C.M.T.C. procurement.

While the Los Angeles Chapter is one of the youngest in the Association it is also one of the most vitile. It is unique in that the membership includes practically all active officers of the Regular Army, National Guard, Organized Reserves and retired officers of the Coast Artillery Corps who reside in Los Angeles county. It is becoming well and favorably known for its participation in civic activities. Invitations have been received for the chapter (as a body) to visit the fleet when in San Pedro Harbor and the great Griffith Park Observatory: here a special lecture was given. These things, in themselves are of no great importance but what is important is the fact that they lead to a high state of morale and a closer brotherly feeling between officers who speak a common language and have similar tastes and interests.

Another chapter which does things in a big way is the one recently organized in Sacramento, California. A report of the activities of this chapter was published in the July-August issue and will not be repeated at this time.

From Seattle, Washington, comes the information that the members of this northwestern outpost have actively supported all of the recent plans for the modernization of the Pacific Coast Defenses and have been instrumental in bringing the needs of the West Coast to the attention of the Representatives in Congress. Another major objective of the chapter is to induce the War Department to establish a National Guard antiaircraft regiment in the State of Washington. This is considered necessary for the protection of the critical points in the northwest and more especially for its effect on the training and instruction of antiaircraft personnel.

All Association activities are not confined to the West. Moving farther East we have a report from the Indianapolis Chapter showing that it held three stated dinners

during the last winter season. These were well attended. The chapter now numbers approximately 66 officers. Of this number 27 attended camp this year.

From Kansas City, Missouri comes the report that plans are under way to stimulate interest in and give more publicity to Coast Artillery affairs. The members of the chapter are contacting all newly appointed Coast Artillery officers and those who move into Kansas City or its environs with the idea of bringing them together on grounds of mutual understanding, respect and coöperation. This chapter also collects nominal dues from members. Most of this is used to purchase ammunition for the use of a pistol team. Plans are under way to develop the social activities. Stated meetings will be held on the first Wednesday of each month beginning in October.

The Philadelphia Chapter reports that meetings are held each month, from October to May inclusive, in conjunction with inactive duty conferences. During the past year an unusual amount of interest was manifested and a gratifying increase in attendance was recorded. Socially this chapter is one of the most active. For the past several years it has been the practice to hold annually a military ball; this is one of the highlights of the social-military activities in Philadelphia. Each year since the inception of this function it has grown in fame and prestige. So great has become its popularity that it was decided to hold a dance in November, thus giving the members two social functions each year. This dance proved a success both socially and financially, therefore, in all probability it will be given a place on the annual schedule. It is the practice of the members of the chapter to assemble at an informal dinner and smoker prior to each inactive duty conference. These dinners have been instrumental in promoting mutual understanding and a feeling of good fellowship.

We hope that this brief résumé of chapter activities will instill new life into some of the other chapters and enable them to adopt programs best fitted to the local conditions.

/ / /

Magnificent

WHEN it comes to winning trophies, accumulating extension school work, attending conferences and subscribing to the COAST ARTILLERY JOURNAL the stalwart soldiers from Southern California usually can be found in the vanguard. Why this is true we do not know, but the pages of the JOURNAL for the past four years bear mute evidence to this fact. As further proof, if any be needed, we take great pleasure in quoting from the commanding officer of the 626th C.A. (HD) with Headquarters in Los Angeles, Calif.:

"It is indeed a pleasure to be able to inclose herewith the subscription cards of each of the 17 officers of my little regiment who have within the past few days completed a tour of active duty at Fort MacArthur."

Such magnanimous support and coöperation fully at-

tests the interest of the personnel of the 626th in their avocation. We strongly suspect that this was induced to a considerable extent by the Commanding Officer, Lt. Col. F. R. McReynolds, who has been one of the staunchest supporters of the Coast Artillery Association and the JOURNAL. To him and his officers go our thanks and appreciation.

/ / /

School Staff and Student Officers, C.A.C.

FOLLOWING is a roster of the instructors and student officers at the several service schools and a civilian educational institution. Counting only Coast Artillery officers the number of officers on school duty this year is 104 as compared to 97 during the previous school year.

COAST ARTILLERY SCHOOL

<i>Instructors</i>	<i>Students</i>
<i>Tactics</i>	
Lt. Col. R. F. Cox	Capt. D. S. Ellerthorpe
Major H. R. Jackson	Capt. W. B. Short
Major R. N. Mackin	Capt. K. L. F. deGravelines
Major F. E. Edgecomb	Capt. J. F. Gamber
Major E. L. Poland (Inf.)	1st Lt. J. R. Lovell
Major O. B. Trigg (Cav.)	1st Lt. E. G. Griffith
Capt. F. M. Paul (A.C.)	1st Lt. C. H. Fernstrom
Capt. L. L. Lemnitzer	1st Lt. J. H. Twyman, Jr.
<i>Artillery</i>	1st Lt. J. T. Darrah
Lt. Col. R. V. Cramer	1st Lt. W. A. Perry
Major J. R. Townsend	1st Lt. A. P. Taber
Major H. McC. Cochran	1st Lt. C. J. Odenweller, Jr.
Capt. N. A. Burnell	1st Lt. A. C. Peterson
<i>Engineering</i>	1st Lt. P. A. Roy
Major D. W. Hickey, Jr.	1st Lt. W. H. Harris
Capt. L. W. Bartlett	1st Lt. A. A. Koscielniak
Capt. Edward Barber	1st Lt. J. B. F. Dice
<i>Enlisted Specialists</i>	1st Lt. J. C. East
Lt. Col. R. T. Pendleton	1st Lt. C. L. MacLachlan
Capt. F. B. Kane	1st Lt. A. C. Gay
Capt. W. L. McPherson	1st Lt. Peter Schmick
Capt. V. C. Stevens	1st Lt. F. P. Corbin, Jr.
	1st Lt. M. M. Irvine
	1st Lt. L. N. Cron
	1st Lt. F. T. Berg
	1st Lt. A. D. Gough
	1st Lt. F. A. Bogart
	1st Lt. M. G. Weber
	1st Lt. A. F. Cassevant
	1st Lt. N. B. Wilson
	1st Lt. E. W. Hiddleston
	1st Lt. P. F. Passarella
	1st Lt. R. K. Kauffman
	1st Lt. A. M. Lazar
	1st Lt. W. F. Spurgin
	1st Lt. C. C. Cloud
	1st Lt. A. R. Pebley (Ma- rine Corps)

Advanced Technical Course

Capt. C. E. Shepherd
 Capt. G. A. Chester
 Capt. W. V. Davis
 Capt. H. P. Gard
 Capt. Armand Hopkins
 1st Lt. E. W. Chamberlain

COMMAND AND GENERAL STAFF SCHOOL

Lt. Col. J. B. Crawford	Major Kenneth McCatty
Lt. Col. G. R. Meyer	Major S. W. Anderson
Major C. R. Finley	Major M. C. Handwerk
Major T. R. Phillips	Major F. L. Christian
Major J. H. Wilson	Major H. S. Johnson
Major H. F. E. Bultman	Major H. W. Cochran
Capt. W. L. Weible	Major A. V. Winton
	Major J. T. deCamp
	Major P. W. Lewis
	Capt. L. L. Davis
	Capt. H. F. Meyers
	Capt. P. B. Kelly
	Capt. J. H. Madison
	Capt. R. W. Crichlow, Jr.
	Capt. P. W. Cole
	Capt. L. A. Denson, Jr.
	Capt. R. H. Kreuter
	Capt. L. S. Smith
	Capt. J. H. Featherston
	Capt. C. V. R. Schuyler
	Capt. F. C. McConnell
	Capt. F. A. Mitchell

ARMY WAR COLLEGE

Colonel J. S. Pratt	Lt. Col. M. J. Hickok
	Lt. Col. W. C. Koenig
	Lt. Col. Charles Hines
	Lt. Col. J. H. Cochran
	Major G. W. Ricker
	Major Homer Case
	Major F. J. McSherry
	Major B. L. Milburn

NAVAL WAR COLLEGE

Major W. M. Goodman

ARMY INDUSTRIAL COLLEGE

Lt. Col. P. S. Gage
 Lt. Col. F. Babcock
 Major F. H. Hastings

AIR CORPS TACTICAL SCHOOL

Major F. G. Epling Major H. N. Herrick

INFANTRY SCHOOL

Major R. E. Turley

MASS. INST. OF TECHNOLOGY

1st Lt. W. L. McNamee

Here Is Your Chance!

FOR a long time the editorial management of the JOURNAL has had under advisement a plan whereby all Coast Artillerymen will be given an opportunity to enlighten the world on any subject believed to be of interest to the service. This would be accomplished through the medium of a section in the JOURNAL to be known as "The Open Forum," "Vox Populi," "You Tell Them" or some similar caption. Regardless of the title the purpose is to give all members of the Corps an opportunity to broadcast their pet theory. Many officers think that present methods, policies, etc., are all wrong. They will eloquently expound and expostulate to individuals or groups. Here is the chance for them to reach a larger audience. Perhaps in your ideas there is a gem which may eventually change present practices and perhaps alter the course of destiny. Why not give it a chance to develop in the bright light of publicity? The write-up need not be long. Anything from one paragraph to 1,000 words. The author's name will be omitted if requested. The introduction of this section in the JOURNAL will be an experiment to test the theory that all members of the Corps should have some medium for the exchange of thought and the free, untrammelled expression of opinion. This should not be construed to mean that the author, under the cloak of anonymity, can heap coals of fire on the heads of individuals or indulge in vitriolic criticisms and acrimonious recriminations of any department of the Government or its policies.

Not least in the value of such a section is the opportunity to relieve suppressed emotions through a safety valve of this character.

So here is the proposition—if you agree that a column for informal discussion, or for presenting matters of exceptional brevity, would add spice to the JOURNAL, send in your contribution. Even if you have nothing more to offer than a desire for an article on a particular subject, your expressed request may provide the impulse which will bring to all something which we would otherwise have missed.

✓ ✓ ✓

Editors Come and Go

IN the July-August issue it was announced that Lieutenant Colonel Fred M. Green would take over the editorship on or about September 1, but "man proposes and God disposes" and September 1 found Colonel Green in Walter Reed General Hospital. For this reason it became necessary for the editor to take a curtain call. This was in the nature of an anti-climax after the curtain had been rung down and the stage cleared. Those who have been unfortunate enough to require admission to a General Hospital know the futility of attempting to predict the time of release; this coupled with the fact that the present editor had nearly completed the prescribed tour of duty in Washington, made it necessary to

change the plans and to adopt measures to insure that the JOURNAL would not be left without a pilot.

At the time of going to press it appears that the editorial mantle will fall on the capable shoulders of Major Aaron Bradshaw, an officer of demonstrated initiative and ability whose record eminently qualifies him for the assignment. Major Bradshaw graduated from the U. S. Military Academy in 1914, was commissioned a second lieutenant of Coast Artillery, and reached his present grade in 1932. He is a graduate of the following service schools:

- Battery Officer's Course, C.A. School, 1921.
- Advanced Course, C.A. School, 1928.
- Command & General Staff School, 1930.

His name is carried on the General Staff Corps Eligible List. All of his service has been in the Coast Artillery Corps where he has had diversified duties and varied experience.

Prior to being ordered to Washington he was executive officer of the 62d C.A. (AA) with station at Fort Totten, N. Y. We wish for him every possible success and we predict that under his guidance the JOURNAL will reach a new high-water mark of interest and usefulness.

* * *

KNOCK-KNOCK

Who's There?

The Coast Artillery National Guard

ON September 25, 1935, Colonel Charles C. Dawes, commanding the 202d Coast Artillery, Ill. N.G., reported the conclusion of a successful camp. Successful not only for the personnel of the 202d but also for the COAST ARTILLERY JOURNAL. In Colonel Dawes' letter he stated that "every officer in this regiment has subscribed to your splendid magazine and have all contributed the necessary \$3.00." A check for \$126.00 sealed the bargain then and there.

But listen to this. On September 20, 1936, Colonel Dawes forwarded a letter from which the following transcripts are quoted:

"(1) Subscriptions of all officers to be changed so that all expiration dates concur—that is, expire with issue of July-August, 1937.

"(2) Subscriptions of all officers to be on "R&B" (renew and bill) basis—billed to, and paid for by, the regiment.

"Will you please arrange to send me bill at once to cover subscription of 42 officers of this command to include issue of July-August, 1937."

It was indeed a pleasure to inform Colonel Dawes that

the 202d was the first organization of any component to attain a 100% subscription status for the JOURNAL. The recent authority to record each officer of that regiment on a "R&B" basis assures that the 202d intends to head the list of organizations supporting the JOURNAL 100%.

This magnificent cooperation has been proffered without hope of reward or expectation of favor. It is hoped the fine example will be the deciding factor in inducing other organizations to follow suit—the reward will be a more interesting and instructive JOURNAL.

Following the example set by the 202d last year, the 250th Coast Artillery, Calif. N. G., was a close second with 100% subscriptions, Colonel Richard E. Mittelstaedt having authorized subscriptions for 33 members of his regiment, who are now recorded as "R&B" subscribers; also billed to, and paid by, Regimental Headquarters.

And that's not all. Read about the 243d R.I.N.G. (Colonel Earl C. Webster commanding). The following is quoted from a letter dated December 19, 1935, from Lt. Col. Earl H. Metzger, senior instructor on duty with the regiment.

"The official motto of the 243d Coast Artillery is 'Game to the last.' The standards of the regiment are high and the *esprit* is such that the personnel feel their regiment is second to none in any phase of National Guard activity.

"Not only will every officer of the regiment subscribe, including the Chaplain, the four Medical officers, a 2d Lt. not Federally recognized and one Warrant officer (Band Leader), but also Regt. Hq., Hq. Btry., and each of the nine lettered batteries. A total of 60 subscriptions."

Major George C. McFarland, Instructor of the 251st Calif. N.G. had this to say in a letter of November 29, 1935: "This regiment is composed of alert officers, all energetic and eager to advance and I know they will derive benefit from the COAST ARTILLERY JOURNAL. There is inclosed a Roster of Coast Artillery officers of the 251st C.A. (AA) all of whom have agreed to become subscribers to the COAST ARTILLERY JOURNAL." A total of 23 subscriptions.

In this galaxy of the illustrious is included the 213th Penn. N.G. (Col. C. J. Smith, Commanding, Major E. C. Scaman, senior instructor). This regiment, one of the most active and progressive, will always be found in the vanguard of any activity having for its purpose the betterment of the Coast Artillery Corps.

The 206th Ark. N.G. (Major Carl S. Doney, Instructor) is near the tape with a total of 20 subscriptions; only a few more needed to be eligible for membership in the Order of the Illustrious. We hope to add materially to this esoteric group and eventually make it encompass the entire Coast Artillery National Guard.

COAST ARTILLERY ACTIVITIES

Office of Chief of Coast Artillery

Chief of Coast Artillery
MAJOR GENERAL A. H. SUNDERLAND

Executive
COLONEL HENRY T. BURGIN

Personnel Section
MAJOR CLARE H. ARMSTRONG

Matériel and Finance Section
MAJOR C. W. BUNDY
MAJOR H. B. HOLMES
MAJOR S. L. McCROSKEY

Organization and Training Section
LIEUT. COL. E. E. BENNETT
LIEUT. COL. C. M. S. SKENE
MAJOR AARON BRADSHAW
MAJOR W. H. WARREN

Plans and Projects Section
LIEUT. COL. JOHN L. HOMER

Fort Monroe News Letter

BRIGADIER GENERAL JOS. P. TRACY, U. S. Army, *Commanding*

COLONEL HORACE F. SPURGIN

Commanding Harbor Defenses of Chesapeake Bay and 2d C.A.

LIEUTENANT COLONEL EUGENE B. WALKER
Commanding 51st C.A.

LIEUTENANT COLONEL FREDERIC A. PRICE
Commanding 52d C.A.

By Major O. B. Bucher, C.A.C.

MAJOR General A. H. Sunderland, Chief of Coast Artillery, arrived on the post on August 20th to attend the meeting of the Coast Artillery Association. In honor of this occasion a special review, followed by a parade, was held on August 21st. General Sunderland, accompanied by a staff of visiting officers took the review. In the evening General and Mrs. Sunderland were guests of honor at a reception and dance held at the Officers' Beach Club, an affair greatly enjoyed by all the members of the Association.

During the morning a demonstration of submarine mine matériel was held; this included the detonation of a mine and the maneuvering of a radio-controlled high-speed target. The target was controlled by special equipment installed aboard the U.S.A.M.P. Schofield. After this demonstration the members inspected the Coast Artillery School, The Casemate Club and the model barracks of Battery "A," 51st Coast Artillery. During the afternoon the officers witnessed a demonstration firing of the 155mm. guns by the 51st C.A., and the firing of the 3" A.A. guns and machine guns by Battery "C," 2d Coast Artillery. The spectators were thrilled to see the target brought down by the "archies" at a slant range 6,000 yards.

General Sunderland presided at the banquet held at the

Beach Club on the night of the 22nd. This was followed by a dance given in honor of the visitors. Sunday was given over to sightseeing trips to the historic points of interest on the Peninsula. The garrison feels highly complimented over the Association's choice of Fort Monroe as its meeting place. We hope to be similarly honored next year.

A baby hurricane paid an unwelcome visit to the post in the late afternoon of July 28th. For a time it appeared that the scenes of August, 1933, would be reenacted. The meteorological station at Langley Field recorded a wind of 71 miles per hour. Some of our beautiful trees were blown down and others were topped by the gale. One large tree crashed through a garage, which luckily was empty. The electric light system went out at 6:00 P.M. and Monroe was in darkness until 4:00 A.M. the following morning. Many residents of the Post were caught in the storm but fortunately no one was seriously injured.

The summer training season has been extremely active both socially and professionally. The climax came with the arrival of the first class of the U. S. Military Academy, 301 strong, on August 17th. The Cadets fired service practices with 3-inch AA, 155mm. and 8-inch railway guns during their stay. They manned the firing batteries and handled their assignments perfectly after a few hours

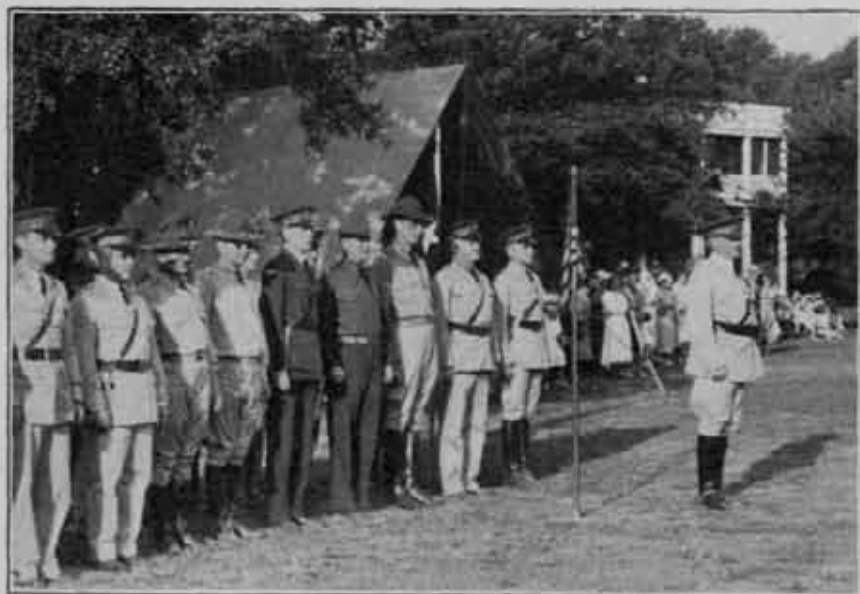

General Sunderland, accompanied by a staff of visiting officers, reviewing the troops of the H.D. of C.B.

drill; target practice was fired with the certainty and precision of a highly trained regular army team. The climax of any AA target practice is the bringing down of the target and this the cadets did with a clean hit; they may well be proud of this feat, for shot after shot burst squarely at the nose of the target before it gave up and slowly settled to a watery grave.

The post was thronged with visitors during the stay of the cadets, and the Officers' Beach Club was the scene of many enjoyable social functions, including a dance each evening.

Like all other training centers Fort Monroe is a beehive of activity during the summer. Organizations ordered here for training included the R.O.T.C. from the University of Pittsburgh and the Virginia Polytechnic Institute; the 260th C.A. (AA) D.C.N.G.; the 246th C.A. (HD) Va. N.G.; six Coast Artillery reserve regiments and a part of the C.M.T.C. trainees from the Third Corps Area. The last of the Reserve units cleared just as the Coast Artillery School opened.

The marriage of Second Lieutenant Halford R. Greenlee, Jr. to Miss Jacqueline Lee Green, daughter of Mrs. Oscar Lee Green, of Phoebus, Virginia, was solemnized at the Post Chapel on Saturday, August 1. The bride was given in marriage by Lieut. Colonel Frank S. Clark. After the ceremony a wedding reception was held by Lieut. Colonel and Mrs. Clark on the lawn of their quarters. The setting under the old trees was one of unusual beauty and hundreds of friends of the young couple gathered to wish them happiness. Immediately after the reception Lieutenant and Mrs. Greenlee left for Portsmouth, New Hampshire, to visit the groom's parents, Captain and Mrs. H. R. Greenlee, U. S. Navy. The happy couple sailed for Panama on September 1.

Another wedding took place on the evening of August 18th when Lieutenant David B. Routh and Miss Helen

Sibella Kimmel, daughter of Lieut. Colonel and Mrs. Manning M. Kimmel, were united in historic St. John's Church, Hampton. Lieutenant Routh was graduated from West Point in 1934 and since that time has been stationed at Fort Monroe. The bride's parents are widely known in Coast Artillery circles. Following the ceremony a reception was held at the home of the bride's grandparents, Captain and Mrs. Harry Reed, of Hampton.

Lieutenant and Mrs. Routh left on a short wedding trip, at the termination of which they will sail for his new station in the Philippine Islands.

A feature of unusual interest at the Officers' Beach Club is the swimming class for the ladies and children, conducted by Lieutenant H. P. VanOrmer, who is an expert swimmer and capable instructor.

Concerts have been given by the 2d Coast Artillery Band each Wednesday and Sunday evening throughout the summer. These concerts have been popular with the residents of the post and the near-by communities.

ATHLETICS

With personnel selected from the eleven teams in the inter-battery baseball league, the Post Team, under the direction of Lieutenant James T. Darrah and Sergeant "Chesty" Cleveland, played the first game of the Fort Monroe-Langley Field series of eleven games to decide the championship of the Southern District; Fort Monroe emerged on the long end of a 6 to 5 score. Following this the Gun Pointers and the Aviators fought one of the most interesting baseball duels ever witnessed on soldier diamonds. With the series standing 5 to 5, the final game was played at Langley Field. This game was a pitching duel between Garris of Monroe and Fisher of Langley. By superior playing Monroe won—10 to 6, giving this post the championship of the Southern District for the first time since 1931. This victory carried with it the privilege of representing the District in the Corps Area Championship series between the group winners as follows: Group I—Fort Monroe, Group II—Fort Hoyle, Group III—Ford Meade, and Group IV—Fort Belvoir.

In this series each of the four group winners played the other group winners twice on a home-and-home basis. Monroe lost the first three games played on foreign grounds but won two out of the three games played on home grounds.

After a four years' lay-off, football was resumed at this post last year. From all indications an impressive array of talent will report to the coach, Major J. L. Hartman, early in September, determined to better last year's record of four victories and five defeats.

Hawaiian Separate Coast Artillery Brigade

News Letter

BRIGADE COMMANDER, BRIGADIER GENERAL ROBERT S. ABERNETHY

CHIEF OF STAFF, COLONEL BENJAMIN H. L. WILLIAMS, C.A.C.

S-1, LIEUTENANT COLONEL E. S. DESOBRY, A.G.D.

S-2, MAJOR JOHN T. LEWIS, C.A.C.

S-3, LIEUTENANT COLONEL RALPH E. HAINES, C.A.C.

S-4, LIEUTENANT COLONEL J. P. SMITH, C.A.C.

Harbor Defenses of Honolulu
16th C.A.

COLONEL G. A. WILDRICK, *Commanding*

Harbor Defenses of Pearl Harbor
15th C.A.

COLONEL EARL BISCOE, *Commanding*

64th Coast Artillery

COLONEL WILLIS G. PEACE, *Commanding*

By Lieutenant William M. Vestal, C.A.C.

THE FLEET'S IN

DAYBREAK, July 15th, saw twenty-six fighting ships of the U. S. Fleet off Koko Head. By six o'clock the battleship *Tennessee* was headed into Pearl Harbor Channel. Eight battle-wagons, four subs, a dozen destroyers, the subtender *Holland*, and the repair ship *Medusa* comprised the visiting fleet. The 64th furnished the guard of honor for Admiral A. J. Hepburn, commanding, when he made his official call upon Major General Drum.

Honolulu kept up a round of hospitality that will long be remembered. Army officers were invited to inspect the *New Mexico* and *Pennsylvania*, and the ladies went aboard a few days later for tea. Most of the Fleet have left for San Pedro after their month's orientation visit which included a week's maneuver in conjunction with ships of the base force stationed here.

DEPARTMENT MANEUVERS

The value of the lessons learned from field exercises is fully recognized. But the fact that there are other benefits of equal importance, to be derived from these exercises is made clear by the improvement in morale of the troops and their eager willingness to return to barracks. Due to plenty of trucks and good handling, HSCAB "mobility" never really got a thorough test. The Brigade found its most intensive work in "retaking" the Ewa beach (South Shore) in cooperation with the 27th Infantry in the final action of the maneuvers. The "aim highers," "caterpillar soldiers" and "datum points" (64th, 55th and 16th) earned much more than a complimentary pat on the back for their "dark-to-dawn" sortie on June 26-27. The assembling of a complete regiment for this counterattack was one of the tests of "mobility." The narrowest escape from death in the action occurred when an "unknown soldier" of a tractor outfit became lost in "No-Man's-Land" and was picked up and transported home by another organization. His buddies spent two hours in the algaroba and sisal (genus cacti to you), but no soldier materialized.

Imagine their joy (?) when Johnnie was found, safe and sound, fully recuperated, in barracks.

The usual guns were put out of action, personnel decimated, and reinforcements frantically called for by sub-sector commanders. The palm for rapidity of movement went to the 8th F.A. for a Battery march from deep in the Ewa sector to Fort Kam in thirty-five minutes. General Drum and his staff were on top of all actions and his "Well done" was worth many paragraphs of flowery praise.

The two-weeks' period ended with much éclat, as Hawaiian Division and Sector-Navy competition in baseball and tennis was impatient for a cessation of hostilities.

SERVICE FIRING

The Harbor Defenses of Pearl Harbor will fire primary assignment armament during August and September. The Railway rifles of the 41st C.A. will be fired at Fort Kamehameha, the guns of the 1st Battalion, 55th C.A. from Fort Weaver and Barber's Point, and the fixed batteries, Closson, Williston, and Hatch, will hurl large projectiles miles to seaward.



Our New Golf Clubhouse

The Harbor Defenses of Honolulu will fire their AA gun assignments from Fort Weaver. Headquarters and "D" batteries of the 16th and the Combat Train of the 55th will conduct AA searchlight practices from the vicinity of Pearl City. Batteries "A" and "E" of the 64th will conduct AA searchlight practices from the same locality and the AA machine-gun battery of the 64th will conduct firings throughout September at Waimanalo or Nanakuli.

BRIGADE ATHLETIC AWARDS

On July 29th Major General Hugh A. Drum, Department Commander; Colonel B. H. L. Williams, representing Brigadier General Abernethy, who was unable to be present, and Mr. Oscar Kellar, representing the Hawaiian A.A.U., collaborated in presenting Sector athletes with awards for their efforts in boxing, basketball, and track and field. With the Brigade massed band doing its bit, seventy-eight athletes received medals, and twenty-eight received "Sector jackets." Many additional medal and jacket winners were back on the mainland, some as members of the Department boxing team en route home from the Olympic tryouts in Chicago.

ALOHA NUI LOA

The departure of Colonel and Mrs. Geo. L. Wertebaker, Harbor Defenses of Honolulu, on the *Republic*, September 17th will be the occasion for sincere lamentations and most fervent "God Speeds" from the entire Brigade. "Aloha Nui Loa," and may your tour in Chicago be a most pleasant one.

ATHLETICS

Baseball: With the Sector-Navy League in the fourth and final round, Submarine Squadron Four (Subrons) is well out in front. In second place, the 64th C.A. looks like the army representative that will battle the Schofield Champs for the Department (Army) title. Fort Kam. and Honolulu trail the leaders, with Fleet Air Base, Sector Staff, and Luke Field bringing up the rear.

As this goes to press a radio message from Honolulu brings the tidings that the 64th ball tossers defeated the 35th Infantry team. Also that the Fort Kam. quint defeated the 3rd Engineers. This establishes the athletic supremacy of the Hawaiian Separate Coast Artillery Brigade for 1936.

Corregidor News Letter

BRIGADIER GENERAL JOHN W. GULICK, *Commanding*

COLONEL WILLIAM S. BOWEN, C.A.C., *Executive*

59th Coast Artillery
COLONEL PAUL D. BUNKER
60th Coast Artillery (AA)
COLONEL ALLEN KIMBERLY

91st Coast Artillery (PS)
LIEUTENANT COLONEL CLAIR W. BAIRD
92d Coast Artillery (PS)
LIEUTENANT COLONEL REINOLD MELBERG

By Lieutenant Colonel Oscar C. Warner, C.A.C.

NOW that the smoke of the target practice season has cleared away the 35 seacoast and antiaircraft target practice reports have started their long journey to Washington. What will happen to them before they find a resting place in the archives we cannot predict but a summation of the results will be of interest. Unusual scores were made by Batteries "A" and "F" of the 59th and Batteries "A" and "B" of the 92d.

ANTIAIRCRAFT

Organization	Btry. Commander	Score	Classification
B 60	Lt. McMorrow	64.03	V.G.
B 60	Lt. McMorrow	74.82	Ex.
C 60	Capt. Griffin	65.68	V.G.
C 60	Capt. Griffin	56.16	V.G.
C 60	Capt. Griffin	63.14	V.G.
D 60	Lt. Bodeau	96.93	Ex.
D 60	Lt. Bodeau	69.36	Ex.
D 60	Lt. Bodeau	69.60	Ex.

SEACOAST

Organization	Btry. Commander	Cal.	Range	Score	Classification
A 59	Capt. Viehules	12"	24,246	392.3	Ex.
B 59	Capt. Steward	12"	15,148	189.8	Ex.
C 59	Lt. Diechelmann	12"	15,333	127.8	Ex.
D 59	Capt. Myers	12"	15,000	128.1	Ex.
F 59	Capt. Bates	14"	11,157	185.8	Ex.

Organization	Btry. Commander	Cal.	Range	Score	Classification
F 59	Capt. Schmidt	12"	22,270	509.6	Ex.
G 59	Capt. Bailey	12"M	9,380	70.8	V.G.
G 59	Capt. Bailey	12"M	8,586
A 91	Capt. Olivares	155	12,251	80.9	V.G.
B 91	Lt. Roth	6"	11,565	164.5	Ex.
B 91	Lt. Roth	155	10,800	101.0	Ex.
C 91	Lt. Alba	3"	6,524	132.3	Ex.
C 91	Lt. Alba	3"	6,841	54.3	F.
C 91	Lt. Alba	155	10,451	113.1	Ex.
D 91	Lt. Massello	14"	16,956	122.3	Ex.
E 91	Lt. Johnson	10"	12,762	68.8	V.G.
F 91	Capt. Lamson	155	10,584	92.4	V.G.
G 91	Lt. Steele	6"	10,111	116.3	Ex.
A 92	Lt. Wilson	3"	6,042	333.9	Ex.
A 92	Lt. Wilson	3"	6,869	60.5	F.
B 92	Capt. Gillette	155	13,649	205.8	Ex.
C 92	Capt. Sevilla	155	11,288	71.4	G.
D 92	Capt. Howell	155	11,802	149.5	Ex.
E 92	Capt. Santos	6"	9,922	108.3	Ex.

SUBMARINE MINES

Organization	Btry. Commander	Score	Classification
A 91	Capt. Olivares	100.00	Ex.
G 91	Lt. Steele	100.00	Ex.

A count will show that 17 batteries were rated "excellent," 4 "very good" and 1 "good." With target practice out of the way, all regiments are concentrating on gun-

ners' instruction, instruction in gas defense, beach defense and gunnery schools for officers. Typhoons permitting, beach defense firings and antiaircraft machine-gun firings will be completed by the end of September.

The Air Corps started the new training year auspiciously by sending over an amphibian plane for searchlight drill, thus giving Battery "A" of the 60th new life and hope that a searchlight target practice may become a reality.

With the arrival and departure of the July transport, the garrison experienced more than the usual number of changes in personnel. The outgoing officers and the members of their families will be greatly missed, but service in the Islands being what it is, changes are to be expected and while those who remain deeply regret the departure of friends we are equally sincere in our welcome to the new arrivals. Following a custom of long standing, a reception for incoming and outgoing officers and their families was held at the Corregidor Club between the arrival and departure of the USAT *Grant*. This reception is in lieu of a long series of calls for both arriving and departing officers; it introduces the new arrivals to the members of the garrison and at the same time enables the departing officers to bid farewell to their friends.

The appearance of Corregidor is at its best during the rainy season. Its natural beauty is being improved by the efforts of Major Manly B. Gibson, the arboricultural officer, who is sparing no effort to make two flowering plants grow where one grew before. Notwithstanding his many and arduous duties, Major Gibson has found time to join the ever-growing "Hole-In-One Club"—a perfect shot, not one of those which ricochet off of trees and rocks before coming to rest in the cup.



60th C.A. (A.A.) at musical rifle drill at Corregidor

ATHLETICS

The 59th took high honors in the Enlisted Men's Duckpin league, while in the Officers' League the 60th, under the management of Lt. Col. Kemble, nosed out the staff team by the narrow margin of one game. In the officers' bowling tournament with 48 competitors, Lieutenant Beazley stood number one with an average of 101.7 for the 36 games. Closely following were Lieutenants Lane and Moore with averages of 100.5 and 100 respectively. In the ladies' league, Mrs. Arthur Roth led the field of 37 with an average of 90.9. The duckpins out of the way, the tenpins have come to the front. All leagues are in full swing and both the basketball courts and the bowling alleys are in use almost continuously.

The members of Battery "B," 91st C.A. (PS) are quite proud of the fact that Corporal Yambao, one of the best all-around athletes in the Islands, was selected from among a large number of competitors to participate in the Olympic Games as a member of the Philippine Commonwealth basketball team.

Panama Canal Department News Letter

Department Artillery Officer
COLONEL LEWIS TURTLE, C.A.C.

Fort Amador
COLONEL EARLE D'A. PEARCE
4th C.A. (AA)

Fort Sherman
COLONEL WILLIAM T. CARPENTER
1st C.A.

Fort Randolph
MAJOR HAROLD P. DETWILER
1st C.A.

By Lieutenant Colonel W. C. Foote, C.A.C.

THIS summer sees over one half the Coast Artillery garrison of Panama executing "Change Posts." It will be recalled that in 1934 there was more than the normal personnel turnover because of the change from a three year to a two year tour of duty in the overseas possessions; this is having an effect on the number of officers now due to return to the States. To enumerate all the changes would be to repeat about one third of the Coast Artillery orders issued in the last few months,

therefore we will content ourselves (and spare the reader) by mentioning only the "tops."

Colonel James S. Dusenbury relinquished command of Fort Randolph on July 18 and sailed for Lansing, Michigan, via New York. Major Russell T. George will be in command until September 15, when he will turn over the reins of control to Major Harold P. Detwiler.

Colonel Wm. M. Colvin sails for New York and duty at Headquarters, Fourth Coast Artillery District on

September 15, when Colonel Wm. T. Carpenter will take command of the Harbor Defenses of Cristobal, the 1st Coast Artillery and Fort Sherman. Major Lewis A. Hudgins has moved from Sherman to Fort DeLesseps and has taken over the duties of Atlantic Sector Adjutant from Lieut. Col. J. C. Haw who departed in July for duty at the University of Maine.

FORT AMADOR

A feature of Canal Zone life is the annual Fourth of July track meet, held in the Balboa Stadium. Amador had representatives entered in each event, and these won more than twice as many points as their nearest competitor. Entries are individual rather than by team. Army representation enhances the cordial relations between the military and the civilian population in the tight little Canal Zone.

Dividends recently declared from the profits of the motion picture service are benefiting all posts in the Zone. The Amador swimming beach house has been completely rebuilt, with increased facilities. It is the one spot on the Isthmus that suggests the Beach Club at Monroe, or the Lido Club at Long Beach. A new Golf Club is going up near the main gate. It resembles the Post Exchange Beer Garden (alias the Enlisted Men's Recreation Center) in design but not in purpose. It should be completed about October first, at which time the old wooden club house will come down—unless its earlier collapse has been brought about by termites. These are Panama Canal Department activities rather than post, but Amador is the beneficiary.

Amador's small arms range is a busy place at present. The quarterly small bore competitions have developed added interest in rifle marksmanship which we hope will be reflected in the scores and percentages of those who qualify on the Course "D" range. Corporal Steed, of the Service Battery, rolled up a score of 199 out of a possible 200 with the .22 rifle at 50 yards; we hope he can do as well with the service rifle at 200 yards.

Favorable weather has made it possible for the 4th to adhere fairly close to its antiaircraft gun and machine gun target practice schedule, despite the prevailing low ceilings inherent to the rainy season.

FORT RANDOLPH

The 1st battalion of the 1st Coast Artillery is trying anxiously to get in its AA gun practices. Searchlights have been through their paces, and machine gun practices (all secondary assignments) are partially completed, with Batteries "D" and "E" reporting excellent scores.

The Fort Randolph Basketball team qualified for the 3-cornered elimination contest for the Atlantic Sector Championship. Unfortunately Fort Randolph team emerged on the small end of the score sheet.

FORT SHERMAN

The dry season has made possible an almost uninter-

rupted schedule of training and service practices. Battery "C," after firing an excellent long range 12-inch service practice, added an AA gun and machine gun shoot to its laurels. Battery "F" fired a 155-mm. gun practice and an AA machine gun shoot in August. This month (September) it will conduct a service mine practice. "H" Battery, after firing a 12-inch long range shoot, is working on two AA gun practices, to be followed by a searchlight practice. Headquarters Battery tossed out its quota of 155-mm. shells, sand loaded, unfuzed, with excellent results. (They failed to divulge the score, perhaps through modesty).

On August 20th the 1st Coast Artillery celebrated its Organization Day. The regiment was assembled at Sherman where it was addressed by the Atlantic Sector commander, Brigadier General Frank W. Rowell.

Fort Sherman will appear in the next edition of "Farley's Catalog" (the Postal Directory to you) as it has opened a post office. (Will philatelists covet covers?)

ONWARD AND UPWARD

As this goes to press the welcome news comes from Department Headquarters that the antiaircraft artillery can actually have the dry season in which to shoot, less the time reserved for maneuvers, and that planes will be made available for towing missions. Those who have never served in Panama, particularly on the more aqueous Atlantic side, cannot realize what a boon that is. It will eliminate the countless hours and days spent waiting for a favorable ceiling, dodging rain squalls, hoping for a cloud condition stable enough to get off even one uninterrupted shoot.

With the dry season available for antiaircraft gun and searchlight practices in 1937, and the remaining two-thirds of the year available for AA machine gun and seacoast target practices, one will see a renewed interest in service target practices in Panama.

/ / /

Fort Barrancas Notes

COLONEL ROBERT ARTHUR, C.A.C., *Commanding*
By *Captain M. A. Hatch, C.A.C.*

THE months of July and August are synonymous with summer training activities and this in turn means plenty of hard work for everyone. Notwithstanding this, it invariably happens that because of school details the turnover in officer personnel is greatest at this season of the year; therefore, it was not entirely unexpected when we were able to count but 50% of the allotted officers strength present and available for duty. Naturally this means more work for everyone and a doubling up on assignments.

Fort Barrancas, the Coast Artillery training area for the southeastern part of the United States, finds itself each summer in a whirl of training activities; the extent

These activities may be judged from a tabulation of the organizations that trained here.

The 67th C.A., commanded by Captain William A. Knapp

The 504th C.A., commanded by Lieutenant Colonel Francis M. Ellerbe

The 545th C.A., commanded by Lieutenant Colonel Robert A. L. Indest

Battery "C," 265th C.A. (AA) Florida, N. G., commanded by Captain H. E. Couchman

C.M.T.C. camp of 500 basic and advanced trainees.

R.O.T.C. camp of approximately 250 students under the command of Lieutenant Colonel T. H. Jones.

The instruction in the C.M.T.C. was conducted by members from three Reserve regiments, viz. —

The 524th C.A. (AA) commanded by Lieutenant Colonel C. M. Boyer.

The 925th C.A. (AA) commanded by Lieutenant Colonel C. S. Vance.

The 534th C.A. (AA) commanded by Lieutenant Colonel A. I. Ellerbe.

These camps fully occupied the time from the early part of June to the end of August. All camps functioned smoothly and the training was carried out in a highly efficient manner. In addition to the units above mentioned Barrancas was deprived of the pleasure of having the 540th C.A. (AA) as our guest because of an infantile paralysis epidemic in the locality from which most of the personnel of the regiment is drawn.

Coincident with the arrival of the C.M.T.C. trainees, the southern tip of Florida was crossed by a tropical storm that headed straight for Pensacola. Our famous hurricane order was dusted off and put into operation. Fort Pickens was evacuated, equipment made secure above previous high water levels, and exposed doors and windows boarded up. The training schedule for the first day was discarded and all C.M.T.C. trainees put to work to assist in protecting and securing property. Fortunately the storm curved slightly to the east, the center striking the coast about 40 miles from Pensacola. The wind reached hurricane velocity (75 m.p.h.) but this vicinity escaped serious damage.

Pensacola is now the home of a newly organized "Battery D" of the 265th C. A. Fla. N. G. Captain Archie Mills is the commanding officer and is assisted by Lieutenants Daly and Pasco. To help them get started one officer and one enlisted instructor from this post are present in the armory on drill nights; also we put into service a part of a mortar battery at Fort Pickens. Battery "D" joined the rest of the regiment at Key West Barracks for the summer training.

The coming of September usually marks a cessation of intensive training activities, but this year three officers from the post will go to Atlanta to participate in the Third Army exercise, and later two officers will go to Barksdale Field for a two weeks "contact course."

Harbor Defenses of Sandy Hook

COLONEL L. B. MAGRUDER, *Commanding*

By Lieutenant Colonel E. B. Dennis

HEADQUARTERS BATTERY, 7th Coast Artillery, Captain William C. McFadden commanding, held a service mine practice on August 6, with a resulting score of 99%. Most of the men participating in this practice were recruits with less than a year's service, and therefore deserve real credit for the excellent performance they gave. The mines were planted by the *General Ord*, Captain Charles M. Wolfe commanding, in the excellent time of 101 minutes.

The end of August marked the close of the summer training activities for the National Guard and the civilian components. Due to the fact that the number of officers under orders for a change of station was unusually large there was a marked shortage of regular officers. However, Fort Hancock came through the ordeal without any curtailment of training schedules and with high morale among both the enlisted and commissioned personnel. Many expressions of approval were heard concerning the completeness of the arrangements and the thoroughly efficient manner in which all details were handled.

The Citizens Military Training Camp was conducted under the guidance of Major Delbert Ausmus, ably assisted by the officers of the 514th C.A. (AA). The camp was a model in every respect. The artillery target practice, the highlight of all camps, demonstrated the skill of the citizen soldiers and the efficient instruction by the officers in charge of the training.

The members of the R.O.T.C. from Fordham University and the University of Delaware were in camp during the early part of June. Majors D. L. Dutton and Joseph Kohn were in charge of the training. Target practices were held with 6-in. seacoast rifle, 155-mm. guns, 3-in. anti-aircraft guns and caliber .50 anti-aircraft machine guns. The R.O.T.C. cadets gave an excellent account of themselves during all of these practices and the results fully attested the high quality of the instruction.

The following additional training camps were held at this post: Battery "A" of the 261st, Del. N.G., 619 C.A. (HD), 514th C.A. (HD).

Also a basic training camp was held for a number of newly commissioned second lieutenants of the Coast Artillery Reserves who reported for the first time as officers. With the experience gained this year it is anticipated that subsequent training camps will be bigger and better. Plans are being made for a new camp site and many other needed improvements. The consummation of this project depends entirely upon the availability of funds. A number of enlisted men took the preliminary examination for admission to the West Point Preparatory School. The large number of high school graduates among the men of this command warrants the belief that it will be well represented. Recruiting for the 52d has been resumed; there are a number of vacancies to be filled.

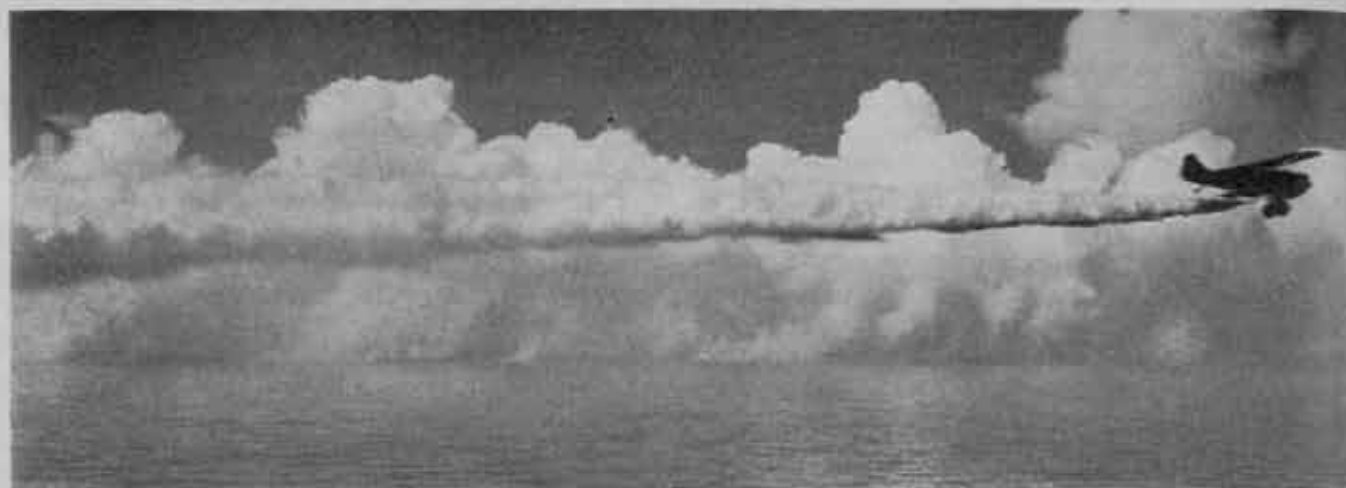

Gas On a Hostile Shore

By MAJOR ALDEN H. WAITT
Chemical Warfare Service

The wind thereupon proving fair the fleet made sail and brought the forces to the coast of Troy. The Trojans opposed the landing valiantly. At the first onset many were slain and one of the noblest of the Greeks, Protesilaus, fell by the hand of Hector.

SEVERAL thousand years later another fleet stood off Gallipoli within cannon shot of Troy. The Turks opposed the landing valiantly. At the first and later onsets many were slain and thousands of the English fell by the hand of the Moslem.

The passage of years has not lessened the problem which confronted Greek and Englishman. The landing of troops on a hostile shore is still one of the most difficult operations of war. If a future defender adds chemical weapons to his inherent defensive advantage the task of the attacking force will become still more difficult.

The infantryman, who bears the burden of securing a beach-head, has given little, if any, thought to the chemical reception he may meet as he hits the beach. It is meet that he think about it now. It will be too late to think when the first unexpected pungency assails his nostrils.

It is necessary to foresee the obstacles, and to outline the ways in which a defender may use chemical agents. We can then find the means to overcome his chemical defense.

The practicable landing places will generally be few owing to the conformation of the shore line, the depth of the water, the presence of surf, or the prevailing winds. The defender will often be able to make a fairly accurate estimate of where a landing is likely to be made and to plan his defense ahead of time. Certain factors that cause selection of a landing beach make the place favorable for chemical defense. For example, the necessity for relatively quiet water makes a landing on the lee shore likely. On lee shores the wind, in general, is favorable for the release of cylinders of gas from headlands or even from beaches.

While the troops are aboard the transports and until

The infantryman has given little thought to the chemical reception he may meet.

they are close to land, they run no great risk from chemicals. There can be little chemical fire against the ships. Certainly the use of non-persistent gases against ships need not be considered, and aside from the presence of tear gas, in combination with shell or shrapnel, there will be no probability of gas from mobile artillery. Armor-piercing shell from shore batteries may carry a proportion of irritant agents mixed with high explosive. Bombing aviation may use phosphorus or mustard-gas bombs, but it is doubtful if a commander would substitute either for high explosive. He seeks destruction and there is no substitute for H.E. as a destructive agent. Nevertheless, some bombs of mustard gas may be mixed with H.E. to increase confusion and to force the wearing of masks.

The first important chemical attack will occur while the troops are being loaded into landing boats and the tows are being formed. During this period the attacker is most vulnerable. A few planes carrying vesicant spray can cover a wide area and cause much damage and confusion. Conditions will favor the use of the chemical spray; so important is this that the defense may hold a number of attack planes loaded with mustard or Lewisite in concealment.

The wind permitting, heavy clouds of non-persistent gasses such as phosgene may be released from headlands in such a way that the gas will cover the area that the incoming small boats must cross.

When the use of gas is practicable during the time the troops are going over the side to the small boats and during the run-in, the hazards of the landing are greatly increased. The mask will be mandatory and landing with a mask is a handicap.

As soon as the first boats are within range of enemy machine guns, the run-in will be covered by a smoke

screen laid by airplanes. This presupposes that the element of surprise has been lost and that it has become necessary to attempt the landing against resistance. So long as smoke persists the enemy will be denied the advantage of aimed fire which of course increases the chance of a successful landing.

As the attack reaches the beach and is striving for a foothold the defense again has an excellent opportunity to employ a chemical spray. Since aviation can swiftly lay a band of chemical a mile long and several hundred yards wide and since there is a large area to be covered, sprays might be of more value at such a time than machine guns or fragmentation bombs.

It is after a beach-head has been gained, however, that the chemical difficulties of the attacking force really begin. Up to this point the use of chemicals has been largely a question of opportunity, but now they offer a sure and definite advantage to the defender.

The first mission of the landing troops is to secure the beach-head and then push ahead to their final objective. Delay is dangerous. They must organize and go forward at once. The forward impulse must not be lost. It is accepted tactical doctrine that in passing an obstacle, whether bridge, defile, or beach, there must be a fanning out in order to gain shoulder room. If hemmed in by natural or created obstacles on the flanks, and the ground to the front is held by determined men, the results will be meager indeed.

Persistent chemicals will be highly effective in increasing the difficulties of natural obstacles. Where these obstacles do not exist, a liberal sprinkling of mustard will often prove a first-class substitute. Should the attacker have ample room to deploy, wide bands of mustard, perpendicular to the shore line, will delay the lateral movement. The chemical may be fired in wide bands by means of land mines, or by artillery, airplanes, or chemical mortars.

The point to be emphasized is the effectiveness of persistent vesicants for hemming in the landing party to prevent the lateral movement so necessary to the attack. The passage is not physically barred by any chemical agent but maneuver over contaminated ground is hazardous, can-

not be accomplished without wearing the mask, and is certain to result in a large number of casualties. The presence of the chemical and the wearing of the mask have a definite effect on the soldier's morale. Also the delay and loss of efficiency caused by wearing the mask is in itself an important factor.

By making full use of the chemical obstacles the defense can hold ground with a smaller number of men than would otherwise be possible. The contaminated areas will generally be swept by fire from machine guns and artillery, thus slowing up the attack and keeping it close to the ground surface where the contamination is greatest.

Now, as to overcoming or neutralizing the chemical defense.

A landing on a hostile shore really starts on friendly soil, weeks or months before embarkation. Perfect gas training and the best possible anti-gas equipment are essentials for a landing force.

The chemical defense organization should be more complete than that ordinarily required for land operations. Each company will require its regular quota of two gas noncommissioned officers. Each battalion, in addition to its gas officer and noncommissioned officer, should have a squad carefully trained in chemical reconnaissance methods and equipped to conduct degassing operations on a small scale. Each regiment should have a similar squad under the direction of the regimental gas officer. This personnel *must* be intelligent—selection by hit-or-miss methods will not do.

Before embarkation the commander should make certain that all anti-gas equipment is available, serviceable, and ready to go over with each landing wave. Every man must know how to use his protective equipment, and understand how to behave when exposed to chemicals. First aid training for gas casualties should be included. There must be repeated exercises aboard ship to accustom the men to wearing the mask for protracted periods. Working while masked develops the ability to fight while masked.

During the landing protection is largely an individual problem. There is little chance for measures for group protection. When the first subwave hits the beach it must



push forward and secure the landing for the succeeding waves. The invader must organize rapidly and drive forward to the principal objective without delay: speed is the essence of the operation. Hence the attacker must be ready with his chemical defensive measures to prevent the attack being slowed up by gas.

Regimental gas officers, with their assistants, should accompany the commander of the first wave, or be put ashore as soon as possible. Their first duty will be an immediate reconnaissance to determine whether or not the defenders are using gas, and particularly whether or not the defense has laid down barriers of mustard. The battalion chemical-defense squads should accompany their units as an integral part of the fighting team. These trained men should be able to detect and distinguish the various gases—and know what to do if any are encountered.

The gas squads should be equipped with protective clothing and heavy cutting tools (small shovels and bolos) to clear lanes through heavily contaminated brush and undergrowth.

It is an open question whether or not it will be possible to burden the men of chemical defense squads with a small amount of degassing material—say about 25 pounds of chloride of lime strapped to their backs in knapsacks. Obviously, degassing will be impossible except on a small scale, but it is essential that some be done. For instance, the degassing of the small space to be occupied by portable radio apparatus is most important. Communication between the landing party and the commander of the operation must be maintained.

Degassing material will also be extremely useful at the

entrance and exits of contaminated trails. Foot burns may be reduced by requiring the men to scuff their feet in the chloride of lime at these places.

Having found the gassed areas, the anti-gas squads must determine their extent, find a way around them, or make a way through them. Some of these men should be used as guides for the advancing troops.

When the beach-head is secured, the anti-gas personnel will have to take measures for degassing those areas through which troops and supplies must pass. Extra precautions will have to be taken to protect food and water. Dangerous areas must be marked, and in some cases sentries posted to prevent passage through them. All precautions against non-persistent gas clouds must be taken, as wind and weather may favor the enemy. Constant inspection of the protective equipment is necessary.

Medical personnel will have special duties if gas is encountered. Under most conditions it will be possible to set up field stations near the beach where mustard casualties may be bathed. Salt water and issue soap will reduce casualties materially, and there will be plenty of salt water at hand.

Active counter measures will, of course, be taken against enemy gas as soon as possible. The artillery will direct counter-battery fire against enemy guns which may be laying down persistent agents. Here again, degassing may be necessary at the battery positions.

No one has ever landed on a beach defended with chemicals—no one knows exactly how to meet the chemical situations that may arise. We can foresee a great many possibilities; and if we can foresee, we can act.

Important Notice to Subscribers

We want you to receive promptly and regularly (bi-monthly) your copy of the Journal; this will depend, primarily, on whether you keep the Editorial Office, 1115 17th Street, N. W., Washington, D. C., informed of any change in your address. Postmasters are required to forward, under Sec. 769, Par. 10, Postal Laws and Regulations, second-class mail addressed to members of the U. S. Military or Naval Service when change of address is due to official orders. Regardless of whether or not this regulation is complied with, your address on our mailing list is incorrect unless you notify us of each change. Incorrect address causes an annoyance to you, an unnecessary expense to the Association, and a nuisance to the mailman.

To insure receiving your copy of the Journal on time (we like to think that you wait impatiently for the appearance of each new issue) and to save your Association money, we urge subscribers to notify us promptly of any contemplated or accomplished change in address. A penny postcard will do the trick; or ask your Postmaster for Form 22-B, fill it out and mail, 1c postage required.

NOTES ON ACTIVE DUTY TRAINING

Foresight and Hindsight

By Colonel Earl W. Thomson, 916th C.A.-Res.

IN the Coast Artillery any target practice may be assumed to be satisfactory if the fire of the battery has been adjusted so that the center of impact is within one probable error of the target, and the battery is ready to open fire for effect. To draw a rather incomplete analogy, it appears that the period of active duty training of a reserve regiment is merely for adjustment and that at the end of the two weeks the civilian, having become adjusted to the life of a soldier, again returns to civilian life.

If there were no need for "corrections" to be applied to the reserve officer personnel, if all the previous teachings of the R.O.T.C., C.M.T.C., and O.R.C. were remembered and obeyed, if every officer fitted perfectly into the position assigned him in the regimental organization, then there would be no need for the active duty training; all we need to do would be to spring to arms on the day of mobilization. Such of course is not the case, and the two-weeks period is for the correction of errors and the proper meshing of the gears of personnel.

Reserve Corps regiments ordered to active duty training as units are in an anomalous position. They have neither enlisted personnel nor matériel and must depend upon the regular organizations for both of these. During the summer training period the supply of these items is limited and often inadequate. Until the present year the regular army officers, overloaded with the multitudinous duties of the summer, were also asked to be the instructors and tutors of the reserve units and to lead these units through drill and conferences. This method was certainly not fair to the overworked regulars, and left many a reservist feeling that he was a perpetual student, being taught year after year, without being given a chance to be the teacher, the leader, the officer.

Early in 1936 the unit instructor and the commanding officer of the 916th C.A. (AA) were informed by higher authority that the regiment would be ordered to active duty training at Fort Monroe from August 9th to 22nd, 1936. They were also informed that a full quota of officers would be assigned and that the officers of the regiment would be asked to do as much as possible of their own training. The unit instructor, Major Robert M. Carswell, immediately laid down a program for the winter and spring months, the aim of which was to train instructors in all the subjects of active duty training that could be learned without access to the matériel. Tentative assignments among the officers of the regiment were

made to key positions. The adjutant, the plans and training officer, the intelligence officer, and the supply officer were told to prepare for their duties, and incidentally to prepare short talks on the scope of their duties in peace and in war. Talks on mobilization, trial shot problems for guns, machine guns, the technique and tactics of searchlights, and close order drill and ceremonies were prepared, given dummy runs at conferences, revamped and corrected by the unit instructor, and then stowed away for later use. This preparation for training was so successful that all of the talks and conferences during the fateful two weeks were given by officers of the 916th except for the conference on the conduct of target practice.

The 916th, at war strength, has 67 Coast Artillery officers assigned to it. The first blow to the idea of unit training came when on July 17th it was announced that 103 officers had been ordered to active duty with the regiment, that the regimental executive was not among these, and that there would be only two field officers in addition to the commanding officer. The unit instructor, together with the commanding officer and his staff, went into executive session and emerged with a manning table whereby the plan previously prepared could be used, so that the officers of the 916th could be assigned to key positions and thereby fulfill their mission as instructors. Of the total of 103 ordered, 93 reported for duty; 45 of these were from the 916th. This probably was the largest group of officers ever assigned for unit training to one regiment, a number too large for the facilities and matériel available at Fort Monroe in view of the fact that the first class of the U.S.M.A. and the 246th Virginia National Guard would also be under training during the same period.

A flexible training schedule as to both subjects and time had been prepared. From previous experience we knew that we might be asked to give the right-of-way to the Cadets, to rainy weather, and to cranky anti-aircraft directors. The schedule had to be constructed so that changes could be made without undue friction or delay.

Previously, the climax of any period of active duty training had been the target practice. This year it was deemed far better to have each officer of the gun battalion get the actual practice of firing trial shot and adjustment problems at towed targets, rather than to train each officer in only one position so that a target practice

could be fired. Under this system approximately thirty officers had a chance to conduct fire, as against three or four who would have commanded during a service practice. All of the officers were rotated in the positions at the gun. There was some criticism from both the regulars and reserves concerning this method, as it naturally failed to produce a smooth running drill, but there is no doubt of its superiority in teaching the officer how to function in all of the positions.

Within the machine gun battalion each officer rotated in the various positions from battery commander to safety officer. The Air Corps was so obliging that each officer was enabled to fire approximately sixteen courses at the towed target. A short machine gun target practice was held during the second week with satisfactory results, sixty-one hits being obtained out of 1,580 rounds. A total of about twenty thousand rounds of machine gun ammunition was fired, so that everyone, including the searchlight and gun groups, had a chance to try the duck guns. Yes, we got politely bawled out for firing after the cease-firing siren had sounded.

The searchlight group, reinforced to a strength of 30, had both practical and theoretical instruction on the use and operation of the searchlights, power plants, comparators and sound locators. Three night exercises, including a service target practice, were conducted, these including the occupation of positions, the location of the targets with the sound locators, and the operation of the lights in the illumination of the targets. The practice was quite successful, the aviator who did the flying commenting that it was the best reserve corps practice in which he had ever participated.

For the purpose of instruction officers were divided into three basic groups: gun, machine gun, and searchlight. During the first week of the training period each group was trained on the matériel to which it was assigned, the instruction being largely done by the regular officers assigned to that matériel. During the second week the



Machine Gun Target Practice: The sleeve target is passing in review

groups were rotated so that each group received instruction on the other two types of matériel; this instruction was given by reserve officers who had had the benefit of the specialized instruction during the previous week. This combination of specialization and generalization of instruction is believed to be capable of producing better results in the broader education of officers in anti-aircraft work.

One of the exercises in which the reserve officers played the parts of both students and teachers, players and umpires, was the regimental tactical problem. The problem was drawn up by the regimental commander and his staff, and was solved by the officers of the regiment in their actual assignments. It was designed to simulate war conditions in the movement into position of an anti-aircraft regiment for the defense of a rear area. The problem was worked out on the terrain. Each officer made notes as to the orders he received, the orders he transmitted to lower echelons, and his actions during the four hours between the issuance of the regimental commander's orders and the time the various units were in position and ready to function. The problem involved the reconnaissance and the selection of positions. Each officer had to be prepared to justify his selection. This was the one occasion during the fortnight in which the regiment functioned as a regiment, and the time and effort spent by the staff in playing out the problem is considered to be justified. The proper meshing of the various time-tables and the functioning of the chain of command can be better done on the ground than in any conference room.

Each morning the nine batteries of the regular garrison at Fort Montoe were turned over to the 916th officers for Infantry drill. At the end of the two weeks we were no longer afraid of our diminutive voices, could maintain cadence, could think several steps ahead, and would find our sabers occasionally in the correct position. Ceremonies in the form of regimental parades were held once each week. During this period the officers showed great improvement in the ability to command.

Probably one of the innovations of the 916th which showed the greatest results was the conference for the key men of the regiment held on the first Sunday morning. Present at this conference were the members of the regimental staff, the battalion commanders and their



Major Comstock of the 1st Battalion explains his orders to the staff and battery commanders

executives, and the C.O. of Battery "A" (Searchlights). The training schedule was explained, assignments were handed out as far as possible, preparation was made for the various conferences and duties. This conference was so productive of results that the regiment began to function immediately after the other officers arrived. S-1 was given a long list of the papers that he must prepare; S-3 was given a list of the instruction he must supervise; S-4 was given a list of supplies he must secure from the various supply agencies. The unit instructor and the commanding officer started early to decentralize the various jobs for which they are responsible.

The officer who had been assigned C.O. of the 2nd (Machine Gun) Battalion was not present at this conference; unfortunately he failed to notify anyone that he would not be present. The effects of this oversight were felt until about Wednesday because others (who had not been notified) had to carry on the duties of the battalion C.O., and they were not cognizant of all that had transpired in the Sunday conference. No plan of active duty training can be complete when reserve officers feel that they can make up their minds on M day whether they want to attend or not; such service should be obligatory after the assignments have been made.

Among the papers that must be ready for issue on the first day are:

- (1) Regimental assignments to staff and batteries;
- (2) Assignment to gun, machine gun and searchlight groups for instruction;
- (3) Assignment for infantry drill and for regimental parades;
- (4) Tentative schedule;

(5) Uniform regulations;

(6) Instruction on infantry drill and the manual of the saber.

All of the above assignments as far as possible should be made upon the basis of the normal regimental duties.

Among the extra personnel that the 916th sported were a publicity officer who had charge of all press relations and "telling the world" of our exploits, and a traffic officer who tried to maintain order within the parking area and on the various convoys which the regiment conducted. Both of these officers were quite successful, as our pictures appeared in the papers several times and our home town friends knew all about our training when we returned; also there were only six red parking tickets handed out by the M.P.'s—explain-by-endorsement-hereon.

There are several errors which are surer than taxes; the inspecting officers at close order drill will always question the cadence and the decibels of the commands; the C.O. and the H.D. will always send word around the second day that the reserve officers are exceeding all 15 m.p.h. speed limits; and some overzealous officer will not hear the cease-firing siren. But in spite of these sins of omission and commission the period of active duty training is a success when everyone within the regiment has had a chance to learn, to lead, and to fire. As Commanding Officer of the 916th Coast Artillery, just returned from active duty training, I feel confident that our errors have been corrected, that we have made the proper adjustment, and that we are now ready to open fire for effect.

Training of the 627th

By Lieutenant Robert R. Lee, CA-Res.

IN 1935 the 627th C.A. (HD) was designated RAI because of its industry and efficiency during inactive duty training. Lieutenant Colonel A. L. Loustalot, the unit instructor, has a way of getting work out of officers that might well be adopted by other instructors. "How about doing correspondence course 'steen—umpty-ump for me, Lieutenant Blank? It's an interesting course and the Regiment gets credit for all you do." This was said with a most persuasive smile, and of course you promised. "How about getting it in by the end of this month?" This with another disarming smile. You counted your engagements and estimated the amount of night work and shuddered, but you promised.

Then, if you did not produce it on schedule, the Colonel saw or wrote to you: "What about that sub-course you promised me by the end of last month?" He wrote and talked in such an injured sort of a way because you had not kept your promise that you turned in "steen" hours on the sub-course right away and promised more.

There was something enticing about the Colonel's

manner that caused you to promise him all that he asked for and if you failed to keep your promise you felt more conscience-stricken than if you had been convicted of beating your wife.

Forty hours of extension school work were required of each officer or a proportional amount for newly assigned officers. After such careful preparation for active duty training it was to be expected that the 45 officers of the regiment, who reported at Fort Funston on August 9, would be well prepared to function in their assigned duties. The schedule included a stiff course for the junior officers and a review course for the senior officers. After firing many ex-caliber courses the regiment was ready for the more serious business of service target practice.

Three service practices were fired with the 155-mm. guns with resulting scores of 90.6, 62.34, and 79.87. One of the practices was fired under a concentration of tear gas, with the personnel of the gun section wearing masks.

In addition to the service practices and analyses, the training schedule included the following subjects: chemi-

cal warfare, orientation, care and preservation of matériel, mobilization, military law, administration, sanitation and first aid, and numerous others. The method of daily examinations was followed, and the results used by the senior officers in making efficiency reports.

One of the principal activities (or lack of activity) performed by a Coast Artilleryman on the Pacific coast is waiting for the fog to lift. A lot of time is consumed in trying to track droplets of water. Perhaps you can get some consolation out of Milton's lines "They also serve who only stand and wait."

The personnel of the regiment presents an imposing array of talent and accomplishments in civilian life and experience in the military art; for example, the regimental commander, Colonel C. J. Mund, began his military career in 1893, served during the railroad strike in 1894, the Spanish American War, was in the Philippine Islands during the Insurrection, was on duty during the fire and earthquake in San Francisco in 1906, and served over two years during the World War. He is now the senior colonel of reserves in the IX Corps Area.

Most of the senior officers of the regiment are veterans of the World War. Practically all of the junior officers are

graduates of the R.O.T.C. units of the Utah State Agricultural College or the University of California. To the camp at Fort Funston came an assistant professor of psychology from the University of Wyoming, an engineer from the Boulder Dam, other engineers, school teachers, insurance salesmen, athletic coaches, recreational directors, lawyers, state and federal civil servants, corporation executives and business men—men from the varied occupations of civil life. Of course all differences were submerged in the common cause—discipline and the determination to get maximum benefit from the training.

The field officers of the Regiment presented a saber to Lieutenant C. D. Wyatt for his outstanding work in inactive duty training. He did 315 hours of sub-courses during the fiscal year 1935-6. During the first six weeks of the fiscal year 1936-7 he completed 114 hours. Now get out your slide rule and figure out how long it will take for him to become Chief of Staff of the Army at that rate.

The following prizes, to be paid for from the regimental fund, will be awarded to officers completing the greatest number of hours of sub-courses during the fiscal



627TH COAST ARTILLERY (HD) RAI, COLONEL C. J. MUND, COMMANDING. FORT FUNSTON, AUGUST 9-22, 1936.

FRONT, left to right: 1st Row: Major Burr, Lt. Col. Loustalot, Col. Mund, Lt. Col. Wise, Majors Knights and Ringwalt. 2nd Row: Lts. Lee, Tully, Stevens, Nelson, Murphy, Neuberger, Partington, Nodder, Burnham, Redd. 3rd Row: Lt. Lee, Capt. Horri, Lts. Sant, Bellueby, Joseph. 4th Row: Lts. Ballard, Garff, McBain, Capt. Reed, Lts. Wright, Layton, Budge, Stiegeler, Klink, Mabie. 5th Row: Lts. Dignan, Lester, Layton, Vergez, Wyatt, Phillips, Law, Lockyer. 6th Row: Lts. Schneider, Lund, Crikshank, Glaese, Manuel, Tripp, Griffin, Downie, Hanson, Chickering.

year ending June 30, 1937. Field officers are ineligible to compete:

- 1st prize—Officer's saber
- 2nd prize—\$7.50 tailor-made O.D. shirt
- 3rd prize—\$5.00 merchandise order on a military supply house
- 4th prize—1 year's subscription to the COAST ARTILLERY JOURNAL.
- 5th prize—1 pair of regimental insignia.

A special feature of the instruction included a mock court-martial. Lieutenant X was tried (and acquitted) for stealing a pair of Major Ringwalt's russet boots, value, \$25.00. The question before the court (which the prosecution could not establish) was how the Major was plutocrat enough to own a pair of \$25.00 boots (Confidentially, he never owned a pair of boots).

The officers of the Regiment attended a most enjoyable dinner dance given at the Officers' Club, Fort Winfield Scott, for Colonel J. C. Johnson, Executive of the 9th Coast Artillery District, who will retire in November after 42 years of service. The officers of the 9th Coast Artillery District presented Colonel Johnson with a set of silverware. Colonel C. J. Mund, the toastmaster, made the presentation. Colonel Johnson was so overcome with

this manifestation of affection and esteem that he was unable to speak for many minutes. Two pairs of eagles were given to Lieutenant Colonel A. L. Loustalot, the unit instructor, by the 627th in anticipation of his expected promotion.

Nearly all of the officers of the Regiment qualified or re-qualified in pistol practice. This was a most satisfactory showing since there was insufficient time and ammunition for firing complete courses. Most of the practice had to be gotten in "dry runs." Dry runs, simulated practices, hypothetical data—these constitute much of a Reserve officer's training; yes, these and problems on paper. We can, perhaps, make a complicated analysis of practice by the book, but be stumped by Private Brown's inquiry (some time after M day) as to why this or that gadget works the way it does. After "M" day many of us whose soldiering has been confined largely to "dry runs" will learn many things that cannot be taught in a sub-course, or even in ADT with only a skeleton organization and the simulated problems.

The 627th Coast Artillery completed its period of active duty training with a realization that this is so, and with a mixture of humility for its limitations and pride in its achievements.

Field Training of the 244th C.A. (TD), N.Y.N.G.

By Major Benjamin Bowering

AFTER spending two weeks last summer with the doughboys at Camp Smith, N. Y., the 244th, (Colonel Mills Miller, commanding) returned to its old camping ground at Fort Ontario, and showed in a big way that the year's lay-off from their duties as artillerymen had not impaired the regiment's efficiency in firing the 155-mm. guns. In fact, the practices fired this year were, as a whole, better than any previously fired by the regiment. Ranges were in excess of 12,000 yards and several batteries beat the "K" factor of 20 seconds. One score of over 100 was made, and several others between 90 and 100.

One of the special features of this year's movement to and from camp was the motor convoy with overnight bivouac at Binghamton. In previous years the regiment always had moved by rail. The smooth and efficient manner with which the large convoy was handled was a tribute to the efficient planning of the Regimental Commander and his staff.

Work did not occupy the stage all the time and many pleasant social events were on the calendar. The personnel of the Regular Army stationed at Fort Ontario were hosts to officers of the Regiment shortly after their arrival. This was returned by the Regiment the following

week with a buffet supper served under canvas in front of the Commanding Officer's tent. The famous 244th Band of 40 pieces put on a concert which added much to the pleasure of all present.

Other social activities consisted of a testimonial dinner to Captain Walter P. Plummer who retires in a few months. "Plum," as he is affectionately known throughout the Regiment, will be greatly missed next year.

Captain Harry (Kid) Greene, the genial adjutant, held his annual birthday party at the Rainbow Inn and, as usual, it was a howling success.

During the camp, reviews were given to Brigadier General Perry L. Miles, USA, commanding the 2d Brigade, Fort Ontario; Brigadier General William Ottmann, commanding the Coast Artillery Brigade, N.Y. N.G.; Colonel Frank K. Fergusson, commanding the Second Coast Artillery District, and Colonel Charles S. Caffery, Infantry, commanding the post of Fort Ontario. A combined review of the 244th C.A. and the 3d Battalion, 28th Infantry, stationed at Fort Ontario, was also given to Master Sergeant Howard H. Fort, 28th Infantry, who was retired after more than 30 years of service.

All in all, the 244th looks back upon the 1936 field training period as one of the most successful in its history.

Active Duty Training at Fort Sheridan

By Lieutenant Colonel E. E. Howard, C.A.-Res.

ON July 31 eight Coast Artillery Reserve regiments from the VII Corps Area completed a most interesting and instructive active duty training period. For the first time all of the Coast Artillery A.A. regiments in the Corps Area were trained together. This made possible the renewal of interrupted friendships between the older officers and enabled them to review verbally the battles of former years fought at Fort Sill, Camp Knox and other training centers. Approximately 250 officers were in attendance and all were in agreement that the policy of sending each regiment to active duty training annually should be continued.

Fort Sheridan, situated on a high plateau where the cooling breezes from beautiful Lake Michigan temper the summer weather, is ideal for training. Of great importance also is the fact that the presence of the 61st C.A. (AA) makes it possible to conduct antiaircraft target practice and to actually work with antiaircraft matériel. While one may learn the theory of antiaircraft gunnery from textbooks, it is necessary to supplement this with actual field work where the matériel can be studied. In addition to the essential artillery subjects, the program of training included calisthenics, close order drill, the tactical employment of antiaircraft artillery and staff and command post exercises. The organizations present, and the commanding officer of each, were as follows:

Organization	Locality	Commanding Officer
507th C.A. (AA)	Iowa	Lt. Col. H. E. Pride
515th C.A. (AA)	South Dakota	Major H. W. Frankenfeld
527th C.A. (AA)	Missouri	Major A. S. Turner
537th C.A. (AA)	Minnesota	Colonel A. H. Conary
538th C.A. (AA)	Kansas	Major Ernest Boyce
955th C.A. (AA)	Minnesota	Lt. Col. F. C. Tenney
958th C.A. (AA)	Ark. and Mo.	Lt. Col. F. C. Carl
960th C.A. (AA)	Kansas	Lt. Col. G. G. McCaustland

The regimental commanders handled their units entirely. All the commanders had the benefit of war service and their instruction did much to make officers of the young men who have recently joined the regiments from the R.O.T.C. These recent graduates are very apt in learning the written and unwritten laws and customs of the service so important in the daily lives of army officers. One of the most interesting exercises of the camp was the presentation of regimental colors to Lieutenant Colonel H. E. Pride, commanding the 507th C.A. (AA), the regiment which is yet receiving honors for its recent achievement in winning the Coast Artillery Association trophy for general excellence in extension school work. Brigadier General D. T. Merrill was the reviewing officer and presented the colors to Colonel Pride.

An innovation and welcome diversion during the

training period was the march and field exercise of the 61st C.A. (AA). It was impossible to transport all of the officers with the limited amount of Government transportation. However, this proved to be no serious obstacle as plenty of privately owned transportation was available. The reserve officers observed the 61st on the march, saw it go into camp and form a motor park, set up and test out its communications, camouflage the guns and machine guns and serve a hot meal from the efficient rolling kitchens. In the afternoon firing problems with both guns and machine guns were conducted. Many expressions of approval were heard concerning this part of the demonstration and all expressed the hope that similar exercises would be included in future camps.

As one of the old soldiers who played a small part in winning the great war, the writer believes that a number of veterans training with the younger officers provides a much needed "leaven in the dough." Even if this dough is never (k) needed the men who take the reserve training and learn the lessons of service will be better qualified to perform the duties and obligations of citizenship.

The regular army instructors, like all others connected with reserve corps activities, are learning more each year as to how to go about getting the best results from the training period. These camps are becoming so efficient that they constitute Uncle Sam's best investment in war insurance or perhaps assurance against war. The following regular officers were present and worked indefatigably to improve the instruction and make the camp a success:

Major B. L. Flanigen, Senior Instructor
Major S. E. Wolfe, Adjutant and Executive Officer
Major I. B. Hill, Plans and Training Officer
Major E. C. Meade, Instructor
Captain K. C. Frank, Instructor
Captain B. C. Dailey, Instructor.

To Major B. L. Flanigen and Colonel A. H. Conary, the camp commander, much credit for the success of the



AA Gun Firing Point, Fort Sheridan, Illinois

camp is due. They both gave tangible evidence of their devotion to the service and the ideals of the reserve corps. Added to this was their sympathetic understanding tempered by long years of experience. The last official letter from the camp headquarters to the regimental commanders contained the following paragraph:

"The Camp Inspector informed me today that it was

the opinion of the Commanding General that the officers of your regiments were the best disciplined, best dressed and best in observances of courtesies of any group which has been in camp this summer."

There is reason therefore for every member of the Seventh Corps Area AA to be proud of the 1936 camp and his part in it.

Active Duty Training of the 619th C. A. (HD)

By Major A. J. Engelberg, C.A.-Res.

ON August 1, the 619th C.A. (HD), under the command of Colonel George W. Johnston, completed a most interesting tour of active duty at Fort Hancock, N. J. Under the supervision of Lieutenant Colonel Harold F. Loomis, unit instructor, an intensive, well-balanced program of training was covered. All instruction, except part of the artillery, was given by members of the regiment. The armament assigned for training purposes consisted of a battery of 8" railway guns. This was a departure from the practice followed in previous years when the 619th fired only fixed defense armament. Due to the magnificent coöperation on the part of Colonel L. B. Magrader, commanding the Harbor Defense of Sandy Hook, the entire personnel of the 52d and the Hdqrs. Btry. of the 7th C. A. was placed at our disposal for the numerous details necessary to carry out an assignment of this nature. A vote of thanks is due Captain W. F. Putnam for the valuable assistance he rendered in all artillery work. It was due largely to his efforts that a successful target practice was fired. In preparing for service practice the regiment achieved a long-desired ambition in that every officer below field grade was given an opportunity to fire a sub-caliber problem identical in every respect (except range) with service practice. During these problems officers were assigned to the various key positions both at the gun emplacements and in the range section. Captain D. B. Wilson, who had recently attended the Coast Artillery School at Fort Monroe, gave the regiment the value of this training by instructing the range section in the proper use of the numerous gadgets and the preparation of firing data. After several unavoidable delays the "Battle of Sandy Hook" was fought out to the satisfaction of all concerned and the glory of the 619th.

The firing was by salvo; No. 2 gun was fired about eight seconds after No. 1. This interval permitted the observers to properly identify each splash. It may be of interest to record the peculiar illusion caused by the splash of the eighth shot. From the gun positions it looked as if a dull red flame appeared as the projectile struck the water. This caused considerable anxiety until an explanation was received from the rowing vessel. It appears that the shell had struck the water flat, had started to ricochet, but after travelling a very short distance again struck the water and disappeared. This

caused a wide, low splash which reflected the sun's rays and gave the appearance of an exploding shell. For infantry drill and dismounted ceremonies we were ably assisted by Captain R. C. Lowry. The ceremonies in which the regiment participated consisted of four parades, an escort of the color and a battalion review and inspection. At these formations all positions were filled by Reserve officers.

The final parade and escort to the color was one that will long be remembered by the officers of the 619th since it was the farewell ceremony for our Commanding Officer. This marked the end of 44 years of faithful service in the Army as Colonel Johnston will relinquish his command before the regiment will again be ordered to active duty.

Record practice with the service pistol was held on July 30. Five of the nine officers who fired qualified as marksmen. To Lieutenant Theodore Pyle went high honors. He qualified as a sharpshooter while several others missed this distinction by a very narrow margin.

One of the highlights of our training period was an event not included in the schedule. Through the courtesy of Captain W. C. McFadden, we were invited on board the mine planter *General Ord* for the purpose of observing how a mine field is laid. A total of 19 mines were put down in almost record time and everyone was greatly impressed by the teamwork and smooth functioning of the mine planter detail. To many of the junior officers this proved to be a most interesting demonstration and gave them their first insight into the technique of submarine mine work. Later the regiment visited the mine casemate and received further instruction on this phase of seacoast defense. Another unusually interesting event, not covered in the schedule, consisted of a visit to, and inspection of, the 288th Co. C.C.C., whose camp is located on the military reservation.

From a social point of view the highlight of the training period was a dance given at the Fort Hancock Officers' Club in honor of the officers of the post and their guests.

Viewed from every standpoint the tour of duty was highly satisfactory. Each officer acquired confidence and experience that should better fit him to properly perform the duties and obligations of an officer of the Army.

Basic Thoughts

By Lieutenant J. W. Thornall, C.A.-Res.

THE end of August usually finds the reserve officer cleared from summer training and returned to the humdrum of his normal existence. The morning bugle has been supplanted by the alarm clock but his camp experiences will be rehashed, reviewed, revived and enlarged upon throughout the inactive training year. Often friend John or Jim will say "What a grand picnic he must have had. Nothing to do but listen to lectures and loaf." Nothing could be further from the truth. Days and sometimes evenings are crowded and what a vital and interesting experience his has been! Not only has he learned about this or that gadget or delved into the mysteries of gunnery but he has had an opportunity to form contacts with others intent upon the same mission; this blending of backgrounds and experiences is not to be discarded as inconsequential.

The writer was one of a number of newly commissioned second lieutenants who reported for a course of instruction at a basic camp conducted at Fort Totten, N. Y. The program was prepared with the idea of initiating the student into the various duties required of his grade. It was broad enough to include the essentials of organization, administration and tactics. An attempt to describe the two weeks work in detail would waste space and try the reader's patience. In place of this we will attempt a very brief synopsis of the training.

Some of the officers had recently transferred from the Infantry to the Coast Artillery. For these close order drill and command and saber drill held no terrors but to the great majority these drills were at first something of a surprise, perhaps an ordeal. When troops were not available it was not an uncommon sight to see a platoon of officers being drilled by a fellow officer. Then again it was both instructive and amusing to see the various styles of manual of the saber given a trial. After several days the jerky and sometimes frantic slashings became less frequent and by the end of camp everyone had mastered the technique necessary to use this weapon with grace and dignity.

Very few of the group had any previous experience or even an opportunity to inspect the antiaircraft guns. It is a well recognized fact that the applicatory system of instruction is the best; therefore, the class was divided into groups and the members of the group rotated in all of the duties of the gun crew and data section. No amount of theoretical instruction can equal the experience gained by actually picking gun positions, putting a gun into it, orienting it for firing and the numerous other tasks which must be performed. By our mistakes we learned—and we learned a lot.

After watching several formal guard mounts the student officers were required to actually go through the ceremony, the officers themselves forming the guard detail. Other training activities to which we were initiated

included paper work, a preparation of morning reports, sick reports and the keeping of battery funds; also there was practical training in gas defense including the drill and care of the gas mask. Afterwards this class was given a practical test and the wearers required to pass through a gas filled chamber.

During the second week we participated in a convoy problem of the 62d C.A. (AA) from Fort Totten to Fort Tilden. This proved to be a welcome diversion and also most interesting. The following are some of the author's reflections which the reader may interpret as he chooses.

1. The idea of a basic camp for reserve officers without previous service in grade is fundamentally sound and should be continued. The opinion has sometimes been voiced that it would be better for these officers to attend the regimental camp but with this theory I disagree.

2. A basic camp furnishes the transition step from the class room work and limited drill facilities of the R.O.T. C. unit to a reserve commission when the officer is expected to possess the necessary knowledge and ability to perform a multitude of duties. The practical training and experience with troops in armament is attained first hand and not through classroom work or listening to a lecture.

3. To place totally inexperienced officers in a regimental camp would slow up the training of the more experienced officers, and would make the initial training quite difficult for the newcomers.

4. The majority of the trainees arrive at camp with an open mind, a very hazy idea of what their grade demands and with little or no cash. A refresher course of at least a month's duration would be most helpful in orienting these officers in their new assignments. This would tend to eliminate the dead time now used in getting acclimated in their new surroundings. A month's intensive study by means of an extension course should make an officer's tour more interesting and more valuable to him and to the service.

Testimonial Dinner

By Captain T. C. Huguley, C.A.-Res.

ON September 3 the officers of the 524th C.A.-Res. paid tribute to their instructor, Lieutenant Colonel Gilbert Marshall, by a testimonial dinner given at the Atlanta Club. Colonel Marshall has served as our unit instructor for two tours totalling approximately seven years. To him we feel that we owe our high efficiency rating as a reserve regiment. His instruction and inspiration has been of great benefit. Colonel Marshall was presented with a silver cigarette case as a slight token of our appreciation for his high qualities of leadership, valuable guidance, unflinching courtesy and consideration.

COAST ARTILLERY BOARD NOTES

Any individual, whether or not he is a member of the service, is invited to submit constructive suggestions relating to problems under study by the Coast Artillery Board, or to present any new problems that properly may be considered by the Board. Communications should be addressed to the President, Coast Artillery Board, Fort Monroe, Virginia.

THE COAST ARTILLERY BOARD

COLONEL WILLIAM E. SHEDD, JR., C.A.C., *President*
MAJOR CLARENCE E. COTTER, C.A.C.
MAJOR GORDON B. WELCH, Ord. Dept.
MAJOR ALVA F. ENGLEHART, C.A.C.

MAJOR STANLEY R. MICKELSEN, C.A.C.
MAJOR EUGENE T. CONWAY, C.A.C.
CAPTAIN HOBART HEWITT, C.A.C.
CAPTAIN WALTER J. WOLFE, C.A.C.

SECTION I

Projects Completed Since Last Issue of the Journal

PROJECT NO. 1058—SPOTTER T₅.— This project involved both the T₅ spotter and the T₁ tracker. The tracker is an observing instrument which can be installed at a distance from the director and from which the angular height and azimuth of the target are transmitted to the director by electrical means. The tracker being light in weight, as compared to the director, was intended to facilitate the occupation of observation posts that are difficult of access. One difficulty experienced in earlier tests of the tracker was the lack of facility for applying vertical and lateral deflection corrections. The T₅ spotter, which operates on the principle of the electrical differential, is to be put in series with the data transmission cable to the guns, thus permitting prompt changes to be made in quadrant elevation and azimuth. The results of the tests showed that although the T₅ spotter was satisfactory so far as its electrical operation was concerned, there was but little benefit gained from its use. An adjusting officer, with a telephone head set, can send adjustment corrections to the director and they can be applied almost as quickly as by using the T₅ spotter. It was recommended that the project for development of a spotter be discontinued; however the further development of a tracker as suggested in Project No. 1067 is advocated.

PROJECT NO. 1059—DEPRESSION ANGLE INDICATOR.— The instruments used in these tests were described in the preceding issue of the JOURNAL. The final compilation of data showed that the depression angles were measured with greater precision than the bearings. The accuracy in measuring both depression angles and the bearings is not equal to what is needed for locating targets at long range. The Board recommended that instruments giving a greater precision be developed.

PROJECT NO. 1067—ANTIAIRCRAFT FIRE CONTROL SYSTEM.— The Board has long been concerned with emergency methods for firing antiaircraft guns. This

project was initiated for the purpose of establishing the fundamental considerations which should underlie the development of both standard and emergency systems if both are to be adequate and if it is to be easy to pass from one to the other. A system was devised making use of apparatus readily available. The tracker T₁ furnished the basic pointing data. Fuze range and super-elevation were obtained from a modified range computer M1920. The lead computer, already mentioned under Project No. 1046 in the preceding issue of the JOURNAL, furnished deflections. Firing data were assembled and transmitted to the guns over a T8E3 data transmission system. The guns were laid by matching pointers. Forty rounds were fired at a towed target with results indicating that the system functioned satisfactorily. The Board found that the development of antiaircraft fire control instruments with a view to providing for both standard and emergency methods would be facilitated by subdividing the director function into two parts, one for pointing and one for predicting. Instruments of the tracker type will perform one function; the other (prediction) may be performed by a variety of instruments or even by estimation. The instruments used in the test were found to be satisfactory, as to type, for emergency use and to present distinct possibilities that may lead to the development of cheaper, simpler, and more rugged instruments for antiaircraft fire control which will have sufficient accuracy to warrant their adoption for standard use.

PROJECT NO. 1073—DRAFT OF TRAINING MEMORANDUM ON INSTRUCTIONS FOR COAST ARTILLERY TARGET PRACTICE.— In the draft of the training memorandum that will govern target practices for 1937, a number of changes have been proposed in an effort to make service target practice more nearly approach conditions of actual service. In submarine mine practice, efficiency in planting mines and the maintenance of under-water equipment have been stressed. In antiaircraft gun practice, the scoring formula has been modified to furnish an incentive for firing at high altitudes and one practice is to be conducted under simulated service conditions. Antiaircraft searchlight targets

are to be camouflaged. Only slight changes have been recommended in the requirements for seacoast practices and for antiaircraft machine-gun practices.

SECTION II

Projects Under Consideration

PROJECT NO. 953—RADIO-CONTROLLED HIGH-SPEED TARGET. — Several drills with the radio controlled target were held preparatory to the demonstration for the Coast Artillery Association. A number of minor "bugs" had crept into the control apparatus during the long lay-off, and to correct this condition careful analysis and patience were necessary. The visibility and seaworthiness of the target will be tested during September and October, and an effort will be made to determine whether the present type of control is adequate or whether it should be supplemented by the installation of a gyroscopic rudder control.

PROJECT NO. 1055—PAINT PRIMERS FOR SEACOAST MATÉRIEL. — The paint primers are still undergoing test. The guns to which the priming coats have been applied will have had considerable service by the end of the summer training season, and by that time it is believed that definite conclusions can be reached.

PROJECT NO. 1056—SOUND-POWERED TELEPHONES.— Tests of this equipment have been completed but the results and recommendations are not yet in final form. However, it may be said that the sound-powered telephone compares very favorably with the battery-operated field telephone and, should extended service tests prove it to be durable, it may supplant the latter to some extent. The practical limit of communication with the sound-powered telephone was determined to be about ten miles when using new, W-110, field wire. The limit for the telephone EE-5, with the latest type of handset (the TS-12) was about fifteen miles. Assuming equal durability for both types of equipment, the question is whether or not the advantages accruing from the "batteryless" feature of the sound-powered telephone compensate for the loss of range in communication. The greater range of the local battery telephone is an important advantage because it means a greater margin of operation. In the event of a defective line, this margin might be sufficient to permit communication where the sound-powered telephone might be ineffective.

PROJECT NO. 1063—RADIO SET SCR-194-T3—Seven Radio Sets, SCR-194-T3, were tested by the 61st Coast Artillery (AA) during the Second Army maneuvers. A member of the Board and an instructor from the Coast Artillery School assisted in the test. This included the use of the sets for convoy control, for searchlight and listening post communication, and for inter-battery communication. The test showed that there was a need for radio communication in an antiaircraft artillery regiment, but the SCR-194-T3 set did not fully meet the requirements.

However, it might be used for training purposes pending the development of another one which would provide greater range of transmission and eliminate interference from other sets operating near the same frequency.

PROJECT NO. 1065—FLASHLESS POWDER FOR ANTI-AIRCRAFT GUNS.—Due to the many demands of summer training upon the troops scheduled to conduct the firings for the purpose of comparing the two lots of flashless powder with a third lot of standard powder, this project is being held in abeyance for the present.

PROJECT NO. 1066—SLIP RINGS, ANTI-AIRCRAFT MOUNT.—Antiaircraft mobile gun mount No. 49, equipped with slip rings, as described in the July-August issue of the JOURNAL, has been fired a number of times in various tests and in scheduled practices. To make the test approach target practice conditions the gun is traversed through 360 degrees between courses and, after each firing, the center column, containing the slip rings, is drenched with water. No electrical defect has been traced to the slip ring installation, but it is too early to express an opinion as to either the suitability or desirability of this or similar devices.

PROJECT NO. 1068—MOTOR TRICYCLE.—This motor tricycle was developed from a solo motorcycle by removing the rear wheel and substituting an axle carrying two wheels, equally spaced on either side of the rear fork, with a frame supporting a seat for two passengers. This very serviceable vehicle, loaned for test purposes by a commercial manufacturer, is being put through its paces by selected agencies in the Harbor Defenses of Chesapeake Bay. The Board is considering the value of the motor tricycle in comparison with the motorcycle with side card for emergency transportation in convoy control, transporting observation post details and similar duties.

PROJECT NO. 1069—HELMETS (STRAW AND FABRIC). —These helmets are being tested to determine their suitability as a substitute for other military types of head gear for wear in the tropics or during summer weather. In appearance the helmets are much like the sun helmets which, at one time, were issued in the Philippines. The helmets have been issued to 13 officers and 93 enlisted men at Fort Monroe, and are being worn for all duties, including fatigue. Wearers are enthusiastic. They find that the helmet is markedly cooler and, with the khaki uniform, it is better looking than the campaign hat. The helmet is easily cleaned, can withstand sun and rain, is light in weight and is very comfortable. Only one criticism has been made so far: viz, that the wind whistles through the ventilator holes.

PROJECT NO. 1072 — MACHINE-GUN FIRE-CONTROL SYSTEM, 63D COAST ARTILLERY.—This fire-control system was used for the advanced machine-gun practices of the 63d Coast Artillery (AA) during May and June of this year. A detailed description of the apparatus and its use appeared in the July-August, 1935, issue of the JOURNAL.

The Board has been directed to make a critical analysis of this system in comparison with other similar developments.

SECTION III Miscellaneous

A device developed by an instructor in the Coast Artillery School, for the training of stereoscopic observers, has been submitted to the Board for consideration. While it does not differ in principle from the expensive stereoscopic trainer now in use, it is simple in design and can be constructed easily at any Coast Artillery station. If tests show it to be satisfactory, it will be of great value in the training of observers.

A study is being undertaken to ascertain the need for modification and improvement of the model 1934 searchlight equipment. Several improvements have been suggested by the battery commanders using this matériel.

Some of the points being considered are: making the azimuth clutch on the searchlight more accessible; extending the elevating rack to permit the light to be elevated through the zenith to a total of 135 degrees; and providing a metal cap for better protection of the controller tripod head.

In view of the fact that many of the current target practice reports pertaining to 3-inch antiaircraft guns contain statements indicating an unsatisfactory performance of continuous fuze setters, a special study is being undertaken to determine ways and means of correcting the difficulties with these devices. In project No. 1033, the Board recommended that certain modifications be made in the M5 and M6 fuze setters. One of the purposes of the present project will be to compare the performance of the modified with the unmodified fuze setters. Target practice reports are being scrutinized to determine whether the A1 modification of the M2 fuze setter is giving satisfactory results.

COAST ARTILLERY ORDERS

(Covering the Period July 1 to August 31, 1936)

Colonel Allen Kimberly, from the Philippines, to 69th, Ft. Crockett.

Colonel R. M. Mitchell, from 14th, Ft. Worden, to Hawaii, sailing San Francisco, Nov. 24.

Colonel G. A. Nugent, from Chief of Staff, Second Corps Area, Aug. 31, to home and await retirement.

Colonel W. G. Peace, from Hawaii, to 14th, Ft. Worden.

Colonel G. L. Wertenbaker, from Hawaii, to Second Army Staff, Chicago. Previous orders revoked.

Lieutenant Colonel R. D. Brown, to Panama, sailing San Francisco, Sept. 29. Previous orders amended.

Lieutenant Colonel C. A. Chapman, retired, upon own application, Sept. 30. Previous orders revoked.

Lieutenant Colonel S. S. Giffin, from 62d, Ft. Totten to Org. Res., 3d Corps Area.

Lieutenant Colonel E. B. Gray, retired, physical disability, July 31.

Lieutenant Colonel J. C. Haw, to Asst. P.M.S.&T., Univ. of Maine, Orono. Previous orders amended.

Lieutenant Colonel H. L. King, to home and await retirement.

Lieutenant Colonel C. B. Meyer, from 61st, Ft. Sheridan, to Panama, sailing New York, Dec. 16. Previous orders amended.

Lieutenant Colonel W. R. Nichols, from instructor, C.&G.S. School, Ft. Leavenworth, to Org. Res., 3d Corps Area. Previous orders revoked.

Lieutenant Colonel George Rublen, Jr., promoted Colonel August 1.

Lieutenant Colonel A. H. Warren, from Org. Res., Ft. Hayes, to the Philippines, sailing New York, Jan. 8.

Lieutenant Colonel E. N. Woodbury, to home and await retirement, about Oct. 20. Previous orders amended.

Major H. H. Blackwell, from 62d, Ft.

Totten, to instructor, Va. Natl. Guard, Roanoke.

Major J. H. Cochran, promoted Lieutenant Colonel, July 1.

Major D. M. Cole, retired, physical disability, Aug. 31.

Major I. H. Harrington, relieved from Finance Department, Sept. 20. Previous orders amended.

Major I. C. Haw, promoted Lieutenant Colonel, July 1.

Major I. F. Kahle, promoted Lieutenant Colonel, June 26.

Major C. B. Lindner, promoted Lieutenant Colonel, July 1.

Major J. D. MacMullen, from instructor, Calif. Natl. Guard, San Francisco, to Key West Barracks.

Major Reinold Melberg, promoted Lieutenant Colonel, July 1.

Major M. J. O'Brien, promoted Lieutenant Colonel, July 1.

Major W. W. Rhein, from 13th, Key West Barracks, to instructor, Calif. Natl. Guard, San Francisco.

Major William Sackville, to duty with Org. Res., 3d Corps Area, in addition to other duties.

Major A. H. Warren, promoted Lieutenant Colonel, June 26.

Captain G. B. Anderson, from 8th, Ft. Preble, to Panama, sailing New York, Nov. 12.

Captain H. C. Barnes, Jr., promoted Major, July 1.

Captain E. G. Cowen, from Panama, to 7th, Ft. Hancock.

Captain T. G. Cranford, Jr. (QMC), from Ft. Totten, to student, Quartermaster Corps School, Philadelphia, Sept. 1.

Captain J. T. deCamp, promoted Major, June 26.

Captain W. H. Donaldson, Jr., promoted Major, June 26.

Captain H. P. Gard, from 2d, Ft. Monroe, to student, C.A. School, Ft. Monroe.

Captain F. K. Gurley, from Panama, to 14th, Ft. Worden.

Captain N. T. Haakensen, from 61st, Ft. Sheridan, to Panama, sailing New York, Nov. 12.

Captain W. B. Hawthorne, from Panama, to 63d, Ft. MacArthur.

Captain Armand Hopkins, from 51st, Ft. Monroe, to student, C.A. School, Ft. Monroe.

Captain W. L. Johnson, from Ft. Barrancas, to Key West Barracks, Sept. 10.

Captain P. W. Lewis, promoted Major, July 1.

Captain C. W. McGechan, from 10th, Ft. Adams, to Panama, sailing New York, Nov. 12.

Captain Leif Neprud, from the Philippines, to 3d, Ft. MacArthur.

Captain J. D. Robertson, retired, upon his own application, July 31.

Captain W. C. Rutter, from 3d, Ft. MacArthur, to Panama, sailing San Francisco, Dec. 5.

Captain V. G. Schmidt, from the Philippines, to 11th, Ft. H. G. Wright.

Captain E. W. Timberlake, promoted Major, July 1.

Captain D. C. Tredennick, from 52d, Ft. Hancock, to the Philippines, sailing New York, Jan. 5.

Captain G. W. Trichel (OD), from Aberdeen Proving Grounds, to student, University of California.

Captain G. A. Tucker, from 13th, Ft. Barrancas, to the Philippines, sailing New York, Jan. 5.

Captain L. D. Vichules, from the Philippines, to 6th, Ft. Winfield Scott.

First Lieutenant G. F. Blunda, from 62d, Ft. Totten, to U.S.M.A., West Point, July 20.

First Lieutenant C. C. Cloud, Jr., from 13th, Ft. Barrancas, to student, C.A. School, Ft. Monroe, Aug. 25.

First Lieutenant H. A. Gerhardt, from Hawaii, to 10th, Ft. Adams.

First Lieutenant P. W. Guiney, Jr., from Panama, to 52d, Ft. Hancock.

First Lieutenant E. W. Hackman, from Panama, to 52d, Ft. Hancock.

First Lieutenant W. A. Hampton, from the Philippines, to 63d, Ft. MacArthur.

First Lieutenant G. E. Hill, resigned.

First Lieutenant V. M. Kimm, from Panama, to 2d, Ft. Monroe.

First Lieutenant C. R. Longanecker, from Panama, to 69th, Ft. Crockett.

First Lieutenant William Massello, Jr., from the Philippines, to 63d, Ft. MacArthur.

First Lieutenant L. C. Ratcliffe, from the Philippines, to 69th, Ft. Crockett.

First Lieutenant J. A. Sawyer, to 6th, Ft. Winfield Scott, upon completion of foreign service.

First Lieutenant E. C. Somerville, from Hawaii, to 8th, Ft. Preble.

First Lieutenant E. O. Taylor, from the Philippines, to 6th, Ft. Winfield Scott.

First Lieutenant R. F. Tomlin, from 69th, Ft. Crockett, to Hawaii, sailing New York, Oct. 30.

First Lieutenant Robert Totten, transferred to Field Artillery, to Hawaii, sailing San Francisco, Sept. 5. Previous orders revoked.

Second Lieutenant John Alfrey, from 14th, Ft. Worden, to Panama, sailing San Francisco, Dec. 5.

Second Lieutenant W. H. Baynes, from 51st, Ft. Monroe, to the Philippines, sailing New York, Jan. 8.

Second Lieutenant W. N. Beard, from C.A.C., to Corps of Engineers, July 15, and to Ft. McIntosh, for station.

Second Lieutenant W. S. Blair, to 51st, Ft. Monroe.

Second Lieutenant A. S. Buynoski, to 63d, Ft. MacArthur.

Second Lieutenant C. F. Cordes, Jr., to 52d, Ft. Monroe.

Second Lieutenant C. A. Cozart, to the Philippines, Jan. 8, after temporary duty with the 52d, at Ft. Hancock.

Second Lieutenant L. R. Drake, to 69th, Ft. Crockett.

Second Lieutenant S. W. Foote, from 63d, Ft. MacArthur, to Panama, sailing San Francisco, Dec. 19.

Second Lieutenant F. L. Furphy, to 63d, Ft. MacArthur.

Second Lieutenant R. M. Hardy, from 14th, Ft. Worden, to the Philippines, sailing San Francisco, Oct. 8.

Second Lieutenant H. J. Harrison, from 51st, Ft. Monroe, to the Philippines, sailing New York, Jan. 8.

Second Lieutenant G. H. Holterman, to Hawaii, sailing New York, Oct. 30.

Second Lieutenant H. J. Jablonsky, from 51st, Ft. Monroe, to temporary duty U.S. M.A., West Point, and then to Panama, sailing New York, Dec. 16.

Second Lieutenant W. H. Jordan, to 52d, Ft. Hancock.

Second Lieutenant H. J. Katz, to 51st, Ft. Monroe.

Second Lieutenant R. H. Kessler, to 52d, Ft. Monroe.

Second Lieutenant W. H. Kinard, Jr., to 6th, Ft. Winfield Scott.

Second Lieutenant Arthur Kramer, to Hawaii, sailing New York, Oct. 30.

Second Lieutenant L. E. Laurion, from C.A.C., to Corps of Engineers and to Panama for station.

Second Lieutenant H. D. Lind, to 61st, Ft. Sheridan.

Second Lieutenant E. E. Lockhart, to 69th, Ft. Crockett.

Second Lieutenant K. E. Madsen, to 62d, Ft. Totten.

Second Lieutenant R. H. Mattern, to 62d, Ft. Totten.

Second Lieutenant R. J. B. Page, from C.A.C., to Corps of Engineers, July 15, and to Ft. McIntosh, for station.

Second Lieutenant N. T. Perkins, to Panama, sailing New York, Sept. 16.

Second Lieutenant H. P. Persons, Jr., to 6th, Ft. Winfield Scott.

Second Lieutenant J. W. Romlein, to 61st, Ft. Sheridan.

Second Lieutenant N. A. Skinrood, from 52d, Ft. Monroe, to the Philippines, sailing New York, Jan. 8.

Second Lieutenant S. E. Smith, from C.A.C., to Corps of Engineers, July 15, and to Ft. Lawton, for station.

Second Lieutenant C. E. Spann, Jr., to 52d, Ft. Monroe.

Second Lieutenant C. B. Stewart, to 62d, Ft. Totten.

Second Lieutenant Oren Swain, to 6th, Ft. Winfield Scott.

Second Lieutenant E. H. Thompson, Jr., to 51st, Ft. Monroe.

Second Lieutenant B. M. Warfield, to 61st, Ft. Sheridan.

Second Lieutenant B. S. Waterman, from 2d, Ft. Monroe, to the Philippines, sailing New York, Jan. 8.

Second Lieutenant H. B. Whipple, to 2d, Ft. Monroe.

Second Lieutenant J. B. Yost, to 13th, Ft. Barrancas.

Warrant Officer J. C. Coe, from 6th, Ft. Winfield Scott, to Hawaii, sailing San Francisco, Nov. 24.

Master Sergeant W. J. Helmer, 15th, Ft. Kamehameha, retired, July 31.

Master Sergeant Edward Kastner, 52d, Ft. Hancock, retired, July 31.

Master Sergeant Edward Kottke, 14th, Ft. Worden, retired, July 31.

Master Sergeant J. B. McGurley, 10th, Ft. Adams, retired, Aug. 31.

First Sergeant, T. W. Dacey, 4th, Ft. Amador, retired, July 31.

First Sergeant R. F. Fullman, 51st, Ft. Monroe, retired, Aug. 31.

First Sergeant G. S. Hiland, 60th, Ft. Mills, retired, Aug. 31.

First Sergeant William Parks, 6th, Ft. Winfield Scott, retired, July 31.

First Sergeant John Persanskie, 13th, Ft. Barrancas, retired, July 31.

First Sergeant W. R. Ransom, 52d, Ft. Monroe, retired, Aug. 31.

First Sergeant Albert Rice, 64th, Ft. Shafter, retired, Aug. 31.

First Sergeant E. A. Wombacher, 6th, Ft. Winfield Scott, retired, Aug. 31.

Staff Sergeant E. C. Eddy, from 52d, Ft. Hancock, to Warrant Officer, A.M.P. service.

Sergeant William Andrews, 62d, Ft. Totten, retired, July 31.

Sergeant J. M. Dockery, 64th, Ft. Shafter, retired, Aug. 31.

Sergeant J. H. Henry, 6th, Ft. Winfield Scott, retired, July 31.

Sergeant J. E. Kuhn, 62d, Ft. Totten, retired, July 31.

Sergeant W. W. Sweatman, 8th, Ft. Preble, retired, July 31.

How to Avoid Class B

RECENTLY conducted a formal investigation in the case of a young lieutenant who, having done those things which he should not have done, needed something more than a "3.2" reprimand. The evidence was conclusive and I found accordingly.

The lieutenant accepted the findings, waived his right to trial under the 104th Article of War and stated that he would accept the punishment. I thereupon informed him that he would prepare a thesis of not to exceed a thousand words, on the subject "How to Avoid Class B." Possibly the case might have been thrown out on the grounds that the penalty violated the constitutional provision against cruel and unusual punishments, but the culprit did not elect to appeal.

In due course the thesis was produced and accepted as adequate penance for the offense. It fell far short of being a literary masterpiece but the psychological effect of

writing it was highly beneficial. It gave the young officer a new viewpoint. It seems to have cured him of the ills that caused him to become an author. Both his performance of duty and his attitude toward it have shown marked improvement.

A second officer has similarly become an author with excellent results. A third offender, on the point of becoming an author by order, was even more easily cured. What happened in that instance reminds me of the story of the welfare worker who handled the case of a widow whose son had a rash on his body. The welfare worker suggested a bath. Returning a week later she noted that the rash was gone. "See what a good bath did for him?" she remarked. "Why, lady, I didn't have to give him a bath," replied the widow. "I only threatened him with one and the rash all went away."—A COLONEL.

THE FOREIGN MILITARY PRESS

Reviewed by Lieut. Colonel Alexander L. P. Johnson, Infantry

FRANCE

THE FOREIGN LEGION. By General Prételat *et al.* (*La Revue d'Infanterie*, May, 1936.)

The centenary of the French Foreign Legion in June served as the occasion for an unusual tribute to that extraordinary command by the *Revue d'Infanterie*, and it well deserved the honor. Composed of soldiers of fortune, derelicts, and adventurers of all nations, it became one of the most redoubtable military organizations of modern times. It built a colonial empire for France second in importance only to that of the British and in the process covered itself with honor and glory. Its fidelity and acts of valor will long stand as shining examples of military virtue.

Throughout the century of its existence the Foreign Legion has fought in every part of the world. Algiers, Spain, the Crimea, Italy, Mexico, the Franco-Prussian war, Tonkin, Dahomey, Madagascar, the World War, and more recently the conquest of Morocco and the Syrian campaign are but incidents in the anabasis of the Legion.

This interesting number of the *Revue d'Infanterie* may well be regarded as an outline history of the French Foreign Legion.

Nous félicitons à nos braves comrades d'armes de la Légion Étrangère.

ECUADOR

THE INFANTRY BATTALION. By Lieutenant Colonel Carlos Villacreces Garcés. (*Revista Militar*, February-March, 1936.)

The infantry battalion that seeks to increase its fire power by means of an inordinate increase in its automatic weapons will sacrifice much of its mobility and maneuverability, and thus lose materially in combat value.

Even a superficial consideration of the ammunition requirements of automatic weapons will emphasize the shortsightedness of this procedure. At Liao-Yang, for instance, one Russian machine-gun battalion armed with eight Maxims expended 6,000 rounds in one and one-half minutes of firing. This represents a rate of fire of 500 rounds per minute for each gun in action. During the same campaign a Japanese company armed with six Hotchkiss guns expended 6,766 rounds per gun each day. During the World War, the Italians calculated the daily requirements of a machine gun at 4,000 rounds. At Messines even second-line machine guns on a barrage mission fired 13,000 rounds.

Taking the Italian figure as a basis for his calculations,

the author finds, that a machine-gun battalion armed with 64 guns would require 256,000 rounds daily, representing a dead weight of 7,300 kilograms. A standard train (Ecuadorian) would barely be able to transport a three days' supply for one of these battalions. To haul this load a distance of 300 kilometers would keep ten 1½-ton trucks on a constant move. In terms of men and animals it would take 100 pack mules and 200 men to move it 15 kilometers. The cost of the ammunition plus the cost of transport mounts to formidable figures. And to this must be added the cost of repairs and probable replacements considering the limited life of barrels and other parts of the gun. Thus, the author concludes, it would cost \$21,600,000 to keep one of these machine-gun battalions in action for one year. This does not include cost of clothing, equipment, shelter, rations, and pay of personnel.

The efficient functioning of a machine-gun battalion depends largely upon the perfection of the service of its ammunition supply. Failure in this reduces the battalion to impotence. Effective maintenance demands:

- (1) Proximity of munitions plants to the zone of operations;
- (2) An adequate, safe, and homogeneous road net;
- (3) Varied and plentiful means of transportation;
- (4) Ample stores of reserve ammunition;
- (5) Perfect coördination of all transportation;
- (6) Adequate economic capacity of the country.

GERMANY

ENDURANCE RIDE OF A MACHINE-GUN COMPANY. By F. (*Militär-Wochenblatt*, April 25, 1936.)

Endurance rides staged by cavalry officers have become commonplace. It is something new, however, when a run-of-the-mine machine-gun company undertakes a ride of this sort for purposes of training animals and men. That is just what the 4th Machine-Gun Company of the German Schweidnitz Regiment did when it essayed a 420-kilometer (about 280 miles) jaunt. One officer and 30 men participated in this ride undertaken to harden recently received remounts. Each rider carried full pack including steel helmet. The group completed the march in ten days. Daily distances varied from 35 to 69 kilometers. In spite of the trying heat, riders and mounts completed the test in excellent condition.

AIR MANEUVERS OF 1935. By Lieutenant Colonel Dr. Nuber. (*Wissen und Wehr*, June, 1936.)

The British air maneuvers of 1935 included offensive and defensive problems. In the first exercise, July 22-25,

Northland, on the defensive, had an air force of 15 pursuit squadrons, one observation squadron (total planes 192) and antiaircraft artillery consisting of a searchlight battalion, one territorial A.A. brigade, and A.A. signal service. Southland, on the offensive, had 16 bombardment squadrons of 176 ships. Weather conditions generally favored the attacker. Bombardment planes equipped with mufflers flew at altitudes above 6,500 meters and could not be detected by the listening apparatus of the defending A.A. artillery. This forced the defense to depend entirely on its pursuit aviation. Air-ground radio communication functioned satisfactorily, but the attackers nevertheless accomplished several of their missions.

The second exercise, executed near Portsmouth in September, was drawn up to test the efficiency of searchlights and listening devices. The searchlights had great difficulty in picking up hostile airplanes, and in most cases the bombers executed their mission without interference by the defense. The listening apparatus also proved inadequate. In addition to the difficulties occasioned by the use of mufflers, it was found that the speed of sound as compared to the speed of the modern airplanes was so slow that the listening devices were practically useless. The A.A. guns likewise failed on numerous occasions.

Soviet Russia did not conduct separate air maneuvers in 1935, but its aviation did participate extensively in the general army maneuvers in the Caucasus, and in the district of Kiev. The Blue force, consisting of four infantry divisions, two cavalry divisions, one motorized-mechanized brigade, and one air brigade, took advantage of the theoretical unpreparedness of Red to seize Kiev. The Red force consisted of two infantry divisions, one cavalry division, one moto-mechanized brigade, and one air brigade, all in the process of concentrating for the defense of Kiev. Each air brigade consisted of 130-140 airplanes. In addition, the Red air force included a number of four-motored transport planes carrying a 3-company battalion of parachute jumpers. Two additional infantry divisions became available to Red in the later phase of this maneuver. In the decisive phase of the exercise the parachute jumpers carrying machine guns, landed in rear of the Blue cavalry corps. This force is variously estimated from 300 to 1,200 men. There is actually little known about this experiment notwithstanding fantastic newspaper reports. It is interesting to note, however, that Soviet service regulations regard the employment of parachute jumpers under actual battle conditions as impracticable. It certainly would not be practicable in densely populated areas, nor in the proximity of alert troops. Nevertheless we must reckon with the possibility. It is noteworthy that France now contemplates organizing two companies of parachute jumpers on the Soviet model.

MACHINE-GUN BATTALIONS. By 85. (*Militär-Wochenblatt*, June 18, 1936.)

This article is a translation of Major J. R. Mendenhall's account of the operations of the 7th Machine-Gun Battalion at Château-Thierry in June, 1918, as published in the January-February number of *The COAST ARTILLERY JOURNAL*. In conclusion, the translator of this interesting narrative observes that a full account of the action is contained in *Monograph 33, Schlachten des Weltkrieges*, published under the auspices of the German Reichsarchiv.

THE NEW SERVICE REGULATIONS OF THE SOVIET INFANTRY. By 40.

The new service regulations of the Soviet infantry shows some marked departures from the older version. The new texts consist of three parts:

- (1) Garrison training of small units including the school of the soldier, the squad, platoon, company, battalion and regiment.
- (2) Field training of small units: (a) the platoon, company, battalion, and regiment; (b) the rifle squad and grenadier squad.
- (3) Heavy machine-gun units.

The new rifle squad consists of a squad leader and eight men and includes one light machine gun. The rifle platoon consists of three rifle squads and a grenadier squad. The grenadier squad is seven men strong: a leader and six men, three of whom are carriers.

The company is made up of four platoons, a heavy machine-gun section (two guns) and three combat vehicles. Its organization and fire power will materially reduce the company's dependence upon higher echelons for supporting fire.

The new regulations recognize four different steps: the drill step, the route step, the parade step, and double time. The drill step serves to develop the marching power of the infantryman. It is used in all movements about the barracks and on marches not exceeding five kilometers. The route step is the drill step in practical application. The parade step is the drill step of shortened pace and quickened cadence; the feet are planted with greater firmness and bodies are carried with a slight inclination backwards.

The extended order drill includes a new wedge formation with 4-5 paces distance and interval between men.

AIR CASUALTIES IN JAPAN. General information.

According to *Krasnaya Svyezda* the Japanese military and naval air forces lose annually 200 to 255 airplanes and 300 flyers as a result of accidents. The casualty list of the naval air force so far this year includes 50 killed and 40 injured. Damage to matériel is correspondingly high.

BOOK REVIEWS

LES MARAIS DE SAINT-GOND. By Colonel A. Grasset.

Reviewed by Sewell T. Tyng.

It has become the fashion in recent years, noticeable especially among British writers, to minimize the rôle of the French Ninth Army and to disparage the share which Foch personally had in its ultimate success. Colonel Grasset has contributed largely toward rectifying this tendency and toward establishing a true perspective.

The maneuver upon which the Battle of the Marne was based—an attack toward the east by the Army of Paris against the German outer flank (von Kluck) while the British and the French Fifth Army simultaneously attacked northeast and north—depended for its success upon the security of the eastern flank of the three left wing Allied Armies concerned. This was the primary mission assigned to Foch whose army held the base of the vast semi-circular battle-line that extended from Paris to Verdun. His failure to stand fast would necessarily have halted Franchet d'Esperey's advance as well as that of the already hesitant British and would have nullified the strategic advantage of any success that Maunoury might have obtained north of the Marne. If the French Ninth Army had been driven back to the west and southwest as a result of the fighting around the Marshes of Saint Gond, it would have left the Allied line, shaken and enfeebled, facing east between the Marne and the Seine which was the very result sought by the German High Command in its General Instructions of September 5th.

But the evil effects upon the Allied fortunes would not have ended there. The path would have lain open for von Hausen's Saxon Army to continue its march due south on Troyes as von Moltke had prescribed, driving a wedge into the center of the Allied line and separating the four eastern French Armies from the four armies to the west. The retreat of De Langle's Fourth Army toward the southeast would have become an inevitable result; De Castelnau and Dubail, already engaged around Nancy in a desperate struggle against Rupprecht of Bavaria, would have been menaced from the rear, and Sarrail's Third Army and the fortress of Verdun would in all probability have been cut off and isolated.

In short the defeat of Foch would have led to the complete fulfillment of the new plan of operation which the German General Staff had devised on the eve of the Battle of the Marne as a substitute for the discarded Schlieffen Plan.

It is doubtless true that the French Ninth Army was not in a position to make any direct, affirmative contribution toward the maneuver which produced the Allied

victory, but that was not its function. Its rôle, as envisaged by Joffre, was to hold fast while the decisive action developed on its left and on its right. In the general scheme no army commander bore a heavier burden of responsibility than Foch, for if he could do little towards winning the battle, there was no one who could more quickly have lost it.

Like Jellicoe—"the only man on either side who could have lost the war in an afternoon"—Foch, by failing to measure up to his responsibility, might have turned the greatest of Allied victories into irretrievable disaster.

This is the justification for the attention military historians have given to the four-day battle waged by the French Ninth Army and for the painstaking and scholarly analysis of its operations now brought forth by Colonel Grasset.

Written in a style designed to appeal to the general public as well as to the military student, the book is less technical and more readable than the previous standard work on the same subject, *Foch à la Marne* by Commandant Villatte, to which, however, Colonel Grasset renders due acknowledgment.

It is interesting to note that this volume is not limited to an account of the operations of the combatant units, but that considerable space is also devoted to the organization of the staff and services of the Ninth Army and to the difficulties attendant upon the creation of such an organization while in constant contact with the enemy. Great credit is rightly given to an officer of the service of supply, Captain Audibert, for the effective manner in which he organized the rear of the Ninth Army and in particular, on the critical day, when the artillery's stock of munitions was all but exhausted, for the way in which he found and moved forward a new supply.

Colonel Grasset is not a historian of the "debunking" school. He shows a genuine admiration and respect for Joffre and Foch whose outstanding qualities as men and soldiers were never more apparent than in the early days of the war.

Foch has been criticized and called an excited visionary because throughout the battle he issued repeated orders to attack to units already beaten to the verge of disintegration. The author makes it plain that the army commander had no expectation that these orders could be literally obeyed, but a disciplined soldier receiving an order to advance will at least do everything humanly possible not to retreat whatever the circumstances and this was all that Foch hoped to accomplish. There is abundant evidence that he personally had no illusions as to the offensive power of the shattered elements of his Army, but he knew that at all costs they must stand their ground in the general interest, so he ordered them to attack. It was

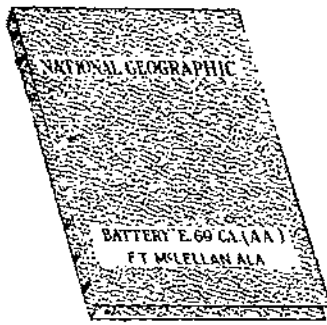

If you cannot keep
your magazines in
place use the
**UNIVERSAL
PERFECTION
MAGAZINE
BINDERS**

with the permanent
lock feature.

The Universal Perfection Magazine lock binders are made in two popular colors (brown and black) of fabrikoid, with permanent lock feature. The crossbar of substantial metal will not bend. Made to fit any size magazine. Magazines cannot be removed from binders without key.

Three lines of lettering in gilt allowed without charge, i.e., name of magazine, organization and location. Instead of location you may substitute "Do Not Remove From Day Room."

PRICES

- No. A.66 Brown or Black Fabrikoid:
1 to 11 Binders inclusive \$2.15 each, any size
12 to 22 Binders inclusive 1.90 each, any size
23 to 30 Binders inclusive 1.80 each, any size
31 Binders and up \$1.75 each, any size

F.O.B. Factory

Quotations for full leather will be given upon request
Order from

THE COAST ARTILLERY JOURNAL

a system based on a psychology not applicable in all cases, but the proof of its merit in this instance is that it worked. Foch's personal conduct, as revealed by Colonel Grasset, points an important military lesson of the vital effect upon the outcome of a battle of an unshakable will to conquer in the higher echelons of command.

The book is a notable contribution to the military history of the World War.

THE LIAOYANG CAMPAIGN. By Lieutenant Colonel A. H. Burne, D.S.O. London: William Clowes. 1936. 150 pages. Paper. 5 Shillings.

Reviewed by Colonel M. B. Garber.

The Russo-Japanese War was fought in 1904-05. It was the only war fought by two major powers between the close of the Franco-Prussian War, 1870-71, and the outbreak of the World War in 1914. It is the only war which affords the military student an opportunity to study the war-making methods of a modernized Japan. Changes in tactical methods, due to the greater use of improved machine guns and quick-firing field guns, were foreshadowed in this war. Notwithstanding these facts, the average army officer is more familiar with the campaigns of Alexander the Great than he is with the campaigns of the Russo-Japanese War.

This book covers the outbreak and the first campaign of the war. It brings out clearly that victory was due to better application of the recognized principles of war, even to the violation of some of these when the situation warranted. It shows in an interesting manner the thorough pre-war study made by the Japanese general staff of the peculiarities of the Russian character, and especially that of the Russian leader, which justified violations of the principles of war. It demonstrates the danger of lack of unified command, and of interference with subordinate commanders in the execution of assigned missions in battle or campaign, to which Russian defeat may largely be attributed. The tactics of the war are subordinated as being "of ephemeral interest only."

Written in a pleasing manner and emphasizing the points which are of particular interest to the military student, one cannot but regret that Colonel Burne did not see fit to cover the entire war in similar vein.

THE TWENTIES: Volume VI of "Our Times." By Mark Sullivan. Charles Scribner's Sons, New York. 1935. xii + 653 pages. 189 illustrations. \$3.75.

Reviewed by Colonel P. D. Bunker.

This volume belies its title by not covering the whole decade; it stops with 1925, thereby planting within our Scotch souls the sneaking suspicion that we have been gypped—in quantity at least.

After a brief survey of conditions as they were in 1920, the author starts his account of the rise and fall of Warren G. Harding and some of his friends. This narrative, occupying half of the book, deals fully and interestingly with the national politics of the period, as interpreted by

A Modern Military Dictionary

By **MAX B. GARBER**

Colonel, U. S. Army

JUST OFF THE PRESS

A complete and up-to-date American
Military Dictionary

TEN THOUSAND TERMS

Ancient and modern
American and foreign

Definitions pertain to all branches of the service, War Department, World War, and current terms, short historical and descriptive articles.

A HANDY, COMPACT, ONE-VOLUME ENCYCLOPEDIA FOR THE PROFESSION OF ARMS

Prices, Postpaid

In waterproof cloth binding.....\$2.50

In artificial leather binding..... 2.75

Mark Sullivan. In discussing President Harding, the author takes great pains to paint him as one whose personal integrity was above suspicion but whose loyalty to old friends and his consequent desire to help them led him into honest mistakes—unfortunate appointments, for example. In his apparent efforts to show us Harding as a well-meaning boy, Mr. Sullivan has seemed, instead, to have presented us with a fairly good drawing of a stuffed shirt.

Past politics is a part—not all—of History, says our author. In order to know the history of an age one must know not only the wars and rumors of war and the politics of a people but also what they read; what they ate and drank, and how much they paid for it; and, perhaps most important of all, what they sang. Thus the second half of the book depicts the rise of Sex in literature and the new poetry, and devotes some seventy pages to a running commentary on the popular songs as they enjoyed their brief moment of popularity. Fortunately for the reader, this part of the book does not confine itself strictly to 1920-1925; starting in with *Smiles* of 1917, it runs merrily through the offerings of Rudy Vallée, Libby Holman, Helen Morgan, and boop-a-doop Helen Kane up to 1929 and even a bit further. There is something nostalgic about being reminded of *My Blue Heaven*, *Saint Louis Blues*, *Valencia*, and *Blue Skies*. Remember where you danced them?

The last 142 pages comprise a condensed summary of the news, day by day, for the years 1919 to 1925, inclusive. Noteworthy chiefly for its sympathetic and interesting treatment, *The Twenties* is in many ways less comprehensive than the yearly chronologies of the *World Almanac*. The account of each year's activities winds up with a neat notice of the important books, plays and movies of the period—a feature you will enjoy more and more as the years roll by. All in all, a book to buy and keep and refuse to lend.

Coast Artillery Activities

Harbor Defenses of Sandy Hook

(Continued from page 379)

The commissioned personnel of the garrison has been materially augmented by the addition of ten lieutenants of the Coast Artillery Reserves who reported early in July for one year's active duty training under the provisions of the Thomason Act. Nine of these officers are graduates of the University of New Hampshire and the other is from Brown University.

By way of entertainment and diversion, trips on the Government boats operating between Fort Hancock and New York are very popular during the summer months. In addition, three commercial boats make regular trips between the Atlantic Highlands and New York City. These trips are made enjoyable because of the facilities for dancing and other forms of recreation. All in all, there is never a dull moment in the post life at Fort Hancock.

COAST ARTILLERY RING



The Coast Artillery Association has approved this ring, but it may be worn by any Coast Artilleryman, whether or not he is a member of the Association. The design, as shown in the illustration, has been worked out with great care. The other side is equally attractive, depicting a fort and the shield of the United States superimposed on a crossed sabre and rifle above the letters U.S.A.

Gold Overlay

To keep the cost within reach of all, the manufacturer has worked out a plan whereby the outside of the ring is 10k. gold over a sterling silver inlay; in appearance this is exactly like the solid gold ring and will wear equally as well.

Men's Rings	10k		
	Solid Gold	Sterling Silver	Gold Overlay
Plain, no stone	\$23.00	\$ 9.50	\$16.00
Ruby	29.30	11.50	22.30
Sapphire	31.50	13.50	24.50
Topaz	31.50	13.50	24.50
Garnet	31.00	14.00	24.00
Amethyst	32.00	14.50	25.00
Tourmaline	34.75	17.00	27.75
Emerald	28.50	13.50	21.50
Black Onyx	26.50	9.50	19.00
Blood Stone	27.00	10.00	19.50

The same design furnished in miniature for ladies.

PRICES ON APPLICATION.

Order From

**THE COAST ARTILLERY
JOURNAL**

1116 Seventeenth Street, N.W.
Washington, D. C.



Measure from this point

Size may then be determined by measuring on printed page.

Standard Loose-Leaf Binder AND Binder for Field Manuals

These binders are a great convenience, if not an actual necessity in all headquarters and battery offices.

The Field Manual Binder is durable and convenient. It protects the manuals and makes it possible to keep them in a permanent file available for ready reference.

Price, \$1.25

In lots of 10 or more
\$1.10 each.



The Standard Loose-Leaf Binder (illustrated in the cut) is especially designed for filing training regulations and other similar War Department documents. Capacity 400 sheets.

Price, \$1.50

In lots of 10 or more
\$1.35 each.

The Coast Artillery Journal

1115 17th STREET, N. W.

WASHINGTON, D. C.



U. S. Army Regulation Sabers

Spartan—Blade, proved steel, heavily nickel plated, deep etching. Plain bone grip. Scabbard, steel heavily nickel plated. The sabre we recommend for all officers.

When ordering state length desired or give height.

Price, f.o.b. factory\$10.00

Presentation Saber. All silver or silver and gold plated. Prices and detailed description furnished upon application.

MINIATURE U. S. ARMY SABERS

Exact reproduction of the regulation sabre, heavily nickel plated, can be furnished with plain or etched blade. A useful and practical gift as a letter opener.

Price—Ornamented Scroll blade . \$1.50
Plain Blade 1.35

A charge of \$1.50 will be made for etching name on blade of regulation sabre or engraving name on scabbard of miniature sabre.

*Write for further information or
place order with*

The Coast Artillery Journal

1115 17th St., N.W. Washington, D. C.

Infantry Drill Regulations

With Rifle Marksmanship, Military Discipline, Customs of the Service, Courtesies and Interior Guard Duty

The subject matter of the text is based on official documents of the War Department. This has been entirely rewritten and especially illustrated to meet the particular requirements of those for whom it is intended.

CONTENTS

Instruction Dismounted Without Arms	The Infantry Pack
Close Order Drill	Shelter Tent Drill
To Include { The Squad Platoon Company Battalion	Rifle Marksmanship
Dismounted Ceremonies	Nomenclature, Care and Cleaning of Rifles
Drill and Combat Signals	Range Practice
Extended Order Drill	Military Discipline, Courtesies and Customs of the Service
To Include { The Squad Platoon Company	Interior Guard Duty

This book provides the service with an essential which has been lacking for a long time. Fully illustrated.

In convenient Field Manual size 4 1/4" x 7 3/8".

Strictly up to date and in accord with the latest training literature of the War Department.

Price 50c per copy, postpaid.

In lots of 10 to 24—10% discount, f.o.b. Wash.

In lots of 25 or more—20% discount, f.o.b. Wash.