

# ATOMIC HYDROGEN MASERS WITH SELF AUTO-TUNE SYSTEM AND MAGNETIC FIELD CANCELLATION SERVO

H. E. Peters, H. B. Owings and P. A. Koppang  
Sigma Tau Standards Corporation  
Tuscaloosa, AL 35403

## Abstract

Atomic hydrogen masers of the classic active oscillator type which produce the characteristic high stability required by standards laboratories, radio astronomers and other critical scientific applications are described. Features of these masers include automatic cavity stabilization, active magnetic field cancellation servo, relatively small size and weight and other characteristics which adapt them well to use in remote field station operation and long term time and frequency related applications requiring the highest performance.

## INTRODUCTION

Sigma Tau Standards Corporation atomic hydrogen masers have evolved from the original atomic and molecular beam research done at Harvard University in the late 1950's and the first operational hydrogen maser standards developed for field use at Varian Associates QED Division in the early 1960's. Further extensive research and development by the National Aeronautics and Space Administration and research at Sigma Tau Standards Corporation funded by NASA, NRL, the USAF and APL (Johns Hopkins University) has resulted in a maser design which is presently being placed in service by the National Radio Astronomy Observatory for the Very Long Baseline Array system of 10 VLBI radio telescopes.

The scientific principles of a classic hydrogen maser are quite straightforward, although in practice very careful attention to the developed state of the art is required to attain a successful device design. In essence, a source of hydrogen atoms is produced by an RF discharge within a glass source bulb; the atoms are collimated by a tubular exit orifice and pass in a beam through a magnetic state selector wherein atoms in the upper hyperfine quantum levels are focussed into a Teflon lined quartz storage bulb located upstream within a microwave cavity which is tuned to the hydrogen transition frequency. When the density of atoms, magnetic field homogeneity and other design parameters are correct, continuous maser action occurs spontaneously and an RF signal is produced, nominally 1,420.405 MHz, which is translated to standard output frequencies by a low noise receiver-synthesizer system.

## I General Design and Performance

The general Sigma Tau Standards Corporation (STSC) hydrogen maser design is described in more detail in references 1, 2 and 3. It is noteworthy that the unique automatic cavity tuning system described in the above references has proven to be very effective in practice and has contributed to

# Report Documentation Page

*Form Approved*  
*OMB No. 0704-0188*

Public reporting burden for the collection of information is estimated to average 1 hour per response, including the time for reviewing instructions, searching existing data sources, gathering and maintaining the data needed, and completing and reviewing the collection of information. Send comments regarding this burden estimate or any other aspect of this collection of information, including suggestions for reducing this burden, to Washington Headquarters Services, Directorate for Information Operations and Reports, 1215 Jefferson Davis Highway, Suite 1204, Arlington VA 22202-4302. Respondents should be aware that notwithstanding any other provision of law, no person shall be subject to a penalty for failing to comply with a collection of information if it does not display a currently valid OMB control number.

1. REPORT DATE <b>DEC 1988</b>	2. REPORT TYPE	3. DATES COVERED <b>00-00-1988 to 00-00-1988</b>			
4. TITLE AND SUBTITLE <b>Atomic Hydrogen Masers with Self Auto-Tune System and Magnetic Field Cancellation Servo</b>		5a. CONTRACT NUMBER			
		5b. GRANT NUMBER			
		5c. PROGRAM ELEMENT NUMBER			
6. AUTHOR(S)		5d. PROJECT NUMBER			
		5e. TASK NUMBER			
		5f. WORK UNIT NUMBER			
7. PERFORMING ORGANIZATION NAME(S) AND ADDRESS(ES) <b>Sigma Tau Standards Corporation, ,Tuscaloosa,AL,35403</b>		8. PERFORMING ORGANIZATION REPORT NUMBER			
9. SPONSORING/MONITORING AGENCY NAME(S) AND ADDRESS(ES)		10. SPONSOR/MONITOR'S ACRONYM(S)			
		11. SPONSOR/MONITOR'S REPORT NUMBER(S)			
12. DISTRIBUTION/AVAILABILITY STATEMENT <b>Approved for public release; distribution unlimited</b>					
13. SUPPLEMENTARY NOTES <b>See also ADA217145. Proceedings of the Twentieth Annual Precise Time and Time Interval (PTTI) Applications and Planning Meeting, Vienna, VA, 29 Nov - 1 Dec 1988</b>					
14. ABSTRACT <b>see report</b>					
15. SUBJECT TERMS					
16. SECURITY CLASSIFICATION OF:			17. LIMITATION OF ABSTRACT <b>Same as Report (SAR)</b>	18. NUMBER OF PAGES <b>7</b>	19a. NAME OF RESPONSIBLE PERSON
a. REPORT <b>unclassified</b>	b. ABSTRACT <b>unclassified</b>	c. THIS PAGE <b>unclassified</b>			

the excellent long term stability and reproducibility exhibited by these masers without significantly degrading the short term stability.

A significant new development in the STSC masers is an automatic magnetic field cancellation servo system which effectively eliminates the perturbing systematic effects on maser stability produced by external magnetic field variations. This servo system, as well as a magnetic field test system, a newly constructed frequency stability measuring system, and experimental results of tests on the STSC hydrogen masers form the remainder of this paper.

## II Magnetic Field Control System

Figure 1 illustrates the dependence of the oscillation frequency of the hydrogen maser on the magnetic field present in the cavity interaction region. As shown in the figure, the frequency variation is quadratically dependent on the field and so approaches zero as the field approaches zero. In practice it is not practical to operate too close to zero field since field inhomogeneities will eventually become important and produce departures from the ideal frequency dependence or create other functional problems.

At a typical internal field used in the STSC masers of 500 microgauss, the fractional frequency variation dependence on the internal field is  $(f - f_0)/f_0 = 9.6 \times 10^{-16}$  per microgauss variation. So, to maintain the magnetic sensitivity to  $1 \times 10^{-14}$  or less for a one gauss external field change, a shielding factor of  $1 \times 10^{+5}$  is required. The STSC hydrogen masers use a very effective four level set of magnetic shields surrounding the cavity region, however unless great care is used in properly annealing the magnetic shield material during fabrication, the above shielding factor is difficult to attain.

To improve upon the static shielding factor an active field stabilization servo system has been developed and is presently used in the STSC hydrogen masers. Figure 2 is a diagram showing the general geometric arrangement of the two outer magnetic shields. It is generally found, as demonstrated later, that the sensitivity of the maser to the horizontal component of the external field is negligible. This is due to the short horizontal magnetic paths and favorable transverse shield spacings. Thus, it is only necessary to stabilize the vertical field component, and to accomplish this a magnetic sensor has been placed in the space between the outer shield and the next shield cylinder top as illustrated in the figure.

The sensor element is a Hall effect probe which is placed near the center of the temperature controlled plate on which some of the maser receiver and control modules are mounted. To increase the probes sensitivity and to raise the probe output voltage well above the noise level, a field enhancement arrangement has been devised using two high permeability plates, one above and one below the probe, with a concentrated field path created by small magnetic posts that direct a concentrated sample of the field through the probe. The two plates are perpendicular to the Z-Axis field direction, so the probe responds mainly to Z-Axis field variations.

Figure 3 is a diagram illustrating the overall magnetic servo system. Coil windings are placed at the ends of the cylindrical shield located below the magnetic sensor assembly and a precision integrated circuit preamplifier is located near the Hall probe. A buffer amplifier to drive the field coils and a current regulator for the Hall probe bias current are located in a small module on the maser frame. The voltage variations developed by the sensor are thus amplified and produce a compensating current in the coil windings which effectively nullifies the Z-Axis field variations between the shields due to external perturbations.

### III Magnetic Field Sensitivity Tests

Tests of magnetic field sensitivity have been performed on several hydrogen masers equipped with the new servo system. The results reported herein are typical. A set of Helmholtz coils one meter in diameter was calibrated in air to produce a known field as a function of coil current. The coils were then placed around the maser to be tested, oriented to produce an external perturbing field in one of the three orthogonal axes.

Two methods were used to evaluate the frequency variations associated with field changes; in one case the test maser frequency was compared with the frequency of another hydrogen maser located remotely from the test station; in the second method the Zeeman frequency was measured and the magnetic frequency shift and shielding factor were calculated. Since the measured magnetic shifts with the magnetic servo on were too small, less than  $1 \times 10^{-14}$  per gauss, to measure by the first method using measuring intervals of the order of 1000 seconds, the Zeeman frequency method was used to obtain the results given in Chart 1.

MAGNETIC TEST PERFORMED ON NRAO MASER SN V-7				
Internal field set at 640 microgauss				
External perturbation 1 gauss				
ORIENTATION AXIS	SERVO ON/OFF	FREQUENCY VARIATION/GAUSS	SHIELDING FACTOR	IMPROVEMENT IN SENSITIVITY
Z-Axis (Vertical)	ON	$5.2 \times 10^{-16}$	4,700,000	} 30/1
	OFF	$1.6 \times 10^{-14}$	160,000	
X-Axis (F To B)	ON	$4.7 \times 10^{-16}$	}> $10^{+6}$	None
	OFF	$3.4 \times 10^{-16}$		
Y-Axis (L To R)	ON	$2.5 \times 10^{-16}$	}> $10^6$	None
	OFF	$1.6 \times 10^{-16}$		

CHART 1. Magnetic Field Sensitivity Test Results

In a stationary installation, typical ambient magnetic field variations are usually less than 10 or 20 milligauss. In mobile situations (traveling clocks), or in installations with nearby large moving magnetic structures, such as elevators, cars or radio telescope dishes, the ambient field variations are unlikely to exceed plus or minus 1 gauss. Therefore the results of tests on the STSC hydrogen masers indicate that magnetic perturbations are not likely to be the dominant source of systematic instabilities.

### IV Frequency Stability Measuring System

A computer based system for measuring phase, frequency and frequency stability has been assembled and programed at STSC for evaluating the performance of the hydrogen masers. A block diagram of the system is shown in Figure 4. The system may be used with any standard input frequency such as 5 MHz, 10 MHz, 100 MHz or higher frequencies which can be offset relative to a standard reference maser output by 1 Hz. In the example given here, the 100 MHz output of one maser is offset relative to the other by 1 Hz using one of the maser synthesizers; the signals are then sent to a double balanced mixer with a one Hz

filter, amplifier and Schmitt trigger circuit which produces a 1 Hz beat pulse. A second 1 Hz reference pulse is generated by division from the 10 MHz output of one of the masers. The two pulses are input to the A and B ports of a counter which continuously measures the periods ( $T_a - T_b$ ), which are sent to an AT compatible computer using the GPIB control bus. The computer calculates and stores the relevant parameters and generates curves and data to be printed out.

## V Frequency Stability Data

Figure 5 shows a plot of data which is continuously accumulated and displayed on the computer screen as the measurement progresses. The curve showing phase, with the scale on left, gives the phase relative to the one Hz difference frequency ( $T_a - T_b$ ) in units of seconds. The relative fractional frequency is calculated from the slope of the phase curve; this is given by the scale on the right with  $\pm 5 \times 10^{-13}$  full scale. The total measurement interval for this curve is 60,000 seconds. The fractional frequency data (Allan Variance) for decade multiples of 1, 2 and 5 seconds is displayed above the phase and frequency curves.

When the measurement is finished, the computer may be commanded to display and to print the stability plot as shown in Figure 6, which is the Sigma Tau plot of the data shown in Figure 5. It should be emphasized that this data has no drift removed.

## Acknowledgments

The authors gratefully acknowledge the support of the National Radio Astronomy Observatory under Contract VLBA-112 as well as the Associated Universities Inc., and the National Science Foundation.

## References

1. H. Peters, B. Owings and T. Oakley, "Hydrogen Masers For Radio Astronomy," 41st Symposium on Frequency Control, May 1987.
2. H. E. Peters, "Design and Performance of New Hydrogen Masers Using Cavity Frequency Switching Servos," 38th Symposium on Frequency Control, June 1984.
3. H. E. Peters and P. J. Washburn, "Atomic Hydrogen Maser Active Oscillator Cavity and Bulb Design Optimization," 16th Annual PTTI Applications and Planning Meeting, November 1984.

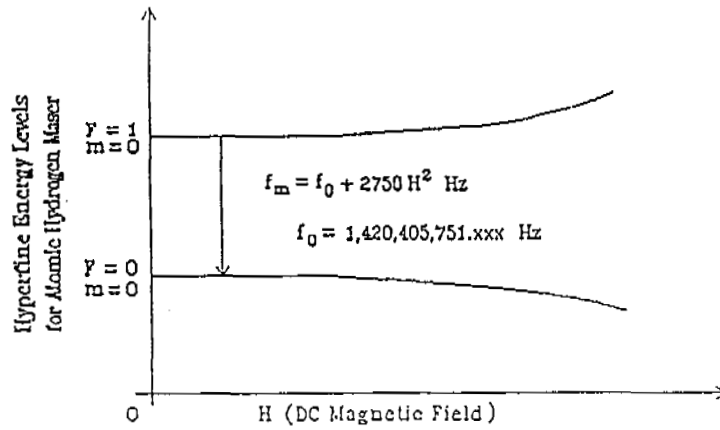

Figure 1. Frequency Dependence on Magnetic Field

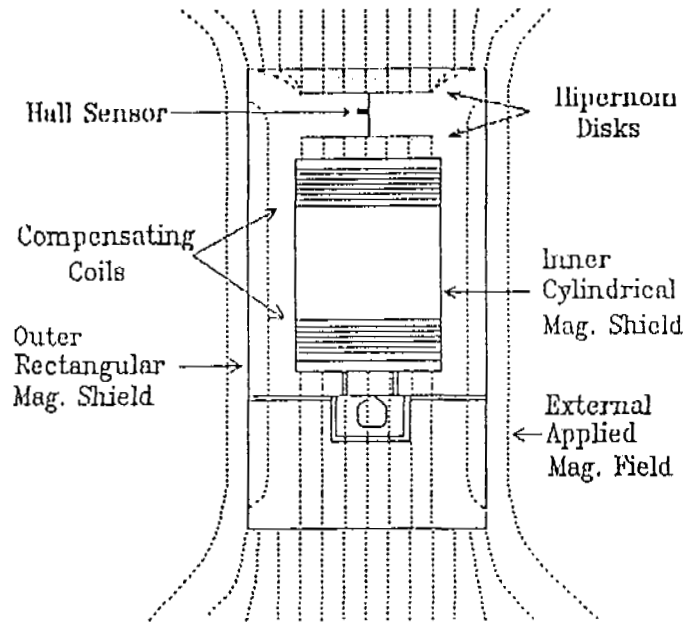

Figure 2. Magnetic Shield and Sensor Configuration

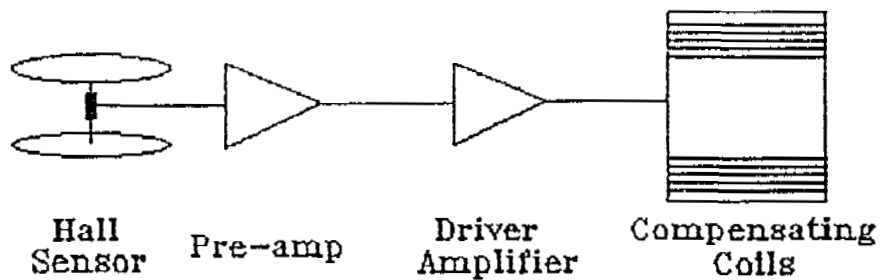

Figure 3. Diagram of Magnetic Servo System

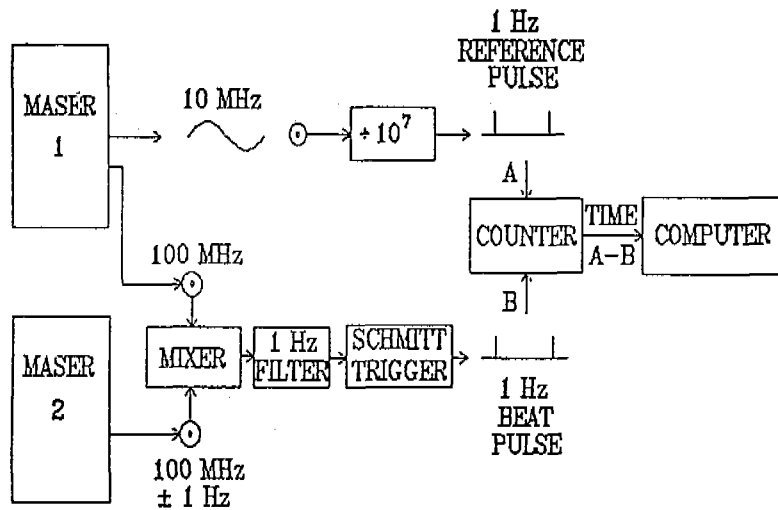

Figure 4. Frequency Stability Measuring System

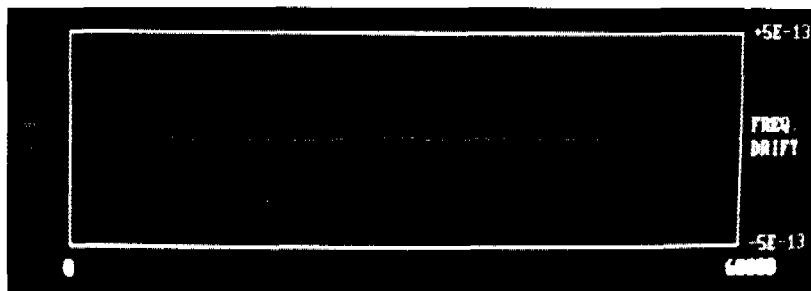

Figure 5. Frequency and Phase Data

TAU= 60000

BATCH START	ST1= 1.230969E-13	ST500= 3.148135E-15
17:19:16	ST2= 6.661331E-14	ST1000= 2.10253E-15
11-18-1988	ST5= 3.263475E-14	ST2000= 1.898178E-15
BATCH END	ST10= 1.89418E-14	ST5000= 2.024251E-15
10:03:55	ST20= 1.193489E-14	ST10000= 9.520592E-16
11-19-1988	ST50= 7.197441E-15	ST20000= 1.643253E-15
	ST100= 5.324645E-15	ST50000= 0
	ST200= 3.851868E-15	ST100000= 0

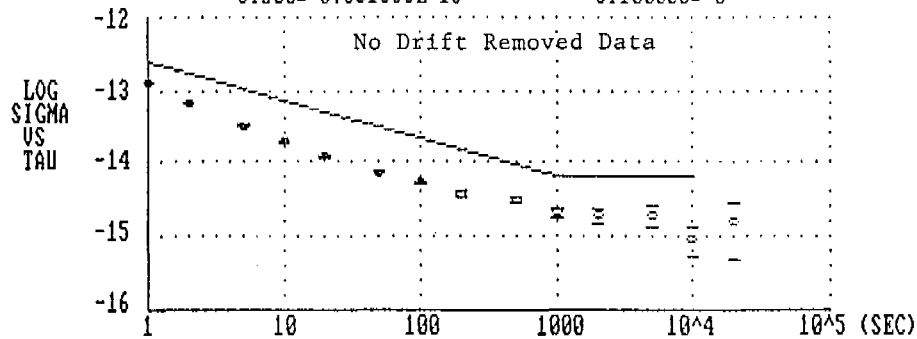

Figure 6. Frequency Stability, 100 Mhz Outputs

## QUESTIONS AND ANSWERS

**DAVID ALLAN, NIST:** What was the measurement floor of the measurement system with the ten to the seventh divider?

**MR. KOPPANG:** We did some measurements on that. It was down in the minus eighteens, I believe. We did a run from one to a thousand seconds and it was from ten to the minus seventeen to ten to the minus eighteen.

**MR. ALLAN:** So that is well below the maser noise. The other question is that with the masers you should have in principle white phase noise in the short term. I don't know whether you thought about using the modified two sample approach or not, but that would show that up nicely if that were the case.

**MR. KOPPANG:** Thank you, we will look into that.

**DR. HARRY WANG, HUGHES AIRCRAFT:** Can you comment on the magnitude of your correction field? Do you see any hysteresis effect of that correction field on the magnetic shielding?

**MR. KOPPANG:** Well, the outer shield has a shielding factor of approximately 300 to 500. The magnetic concentrator magnifies the magnetic field approximately 100. We could calculate the internal fields, but we haven't done that. We haven't checked on any hysteresis effects on the magnetic shields.

**HARRY PETERS, SIGMA TAU CORPORATION:** The shielding factors were derived using fields of plus and minus one gauss. As far as the hysteresis as seen by measurement of the frequency, it was below ten to the minus fourteenth. Inevitably you get hysteresis in the shields, but the servo itself has no noticeable hysteresis because the field is concentrated adequately to get out of the hysteresis range.

**DR. WANG:** Off mike, not decipherable...

**MR. PETERS:** We have this installed in four masers at the moment and the stability is very good as long as we run the concentrator high enough to get out of the instabilities in the Hall probe. We certainly don't have any long term data on the stability of the transverse effect.