



# GRAND CHALLENGES EMERGING PERSPECTIVES for Embedded Processing

*Dennis Healy*

*Microsystems Technology Office*

*Defense Advanced Research Projects Agency*

*[Dennis.Healy@darpa.mil](mailto:Dennis.Healy@darpa.mil)*

*March 6, 2007*

## Report Documentation Page

*Form Approved*  
*OMB No. 0704-0188*

Public reporting burden for the collection of information is estimated to average 1 hour per response, including the time for reviewing instructions, searching existing data sources, gathering and maintaining the data needed, and completing and reviewing the collection of information. Send comments regarding this burden estimate or any other aspect of this collection of information, including suggestions for reducing this burden, to Washington Headquarters Services, Directorate for Information Operations and Reports, 1215 Jefferson Davis Highway, Suite 1204, Arlington VA 22202-4302. Respondents should be aware that notwithstanding any other provision of law, no person shall be subject to a penalty for failing to comply with a collection of information if it does not display a currently valid OMB control number.

1. REPORT DATE <b>06 MAR 2007</b>	2. REPORT TYPE <b>N/A</b>	3. DATES COVERED <b>-</b>	
4. TITLE AND SUBTITLE <b>Grand Challenges Emerging Perspectives For Embedded Processing</b>		5a. CONTRACT NUMBER	
		5b. GRANT NUMBER	
		5c. PROGRAM ELEMENT NUMBER	
6. AUTHOR(S)		5d. PROJECT NUMBER	
		5e. TASK NUMBER	
		5f. WORK UNIT NUMBER	
7. PERFORMING ORGANIZATION NAME(S) AND ADDRESS(ES) <b>DARPA</b>		8. PERFORMING ORGANIZATION REPORT NUMBER	
9. SPONSORING/MONITORING AGENCY NAME(S) AND ADDRESS(ES)		10. SPONSOR/MONITOR'S ACRONYM(S)	
		11. SPONSOR/MONITOR'S REPORT NUMBER(S)	
12. DISTRIBUTION/AVAILABILITY STATEMENT <b>Approved for public release, distribution unlimited</b>			
13. SUPPLEMENTARY NOTES <b>DARPA Microsystems Technology Symposium held in San Jose, California on March 5-7, 2007. Presentations, The original document contains color images.</b>			
14. ABSTRACT			
15. SUBJECT TERMS			
16. SECURITY CLASSIFICATION OF:			17. LIMITATION OF ABSTRACT
a. REPORT <b>unclassified</b>	b. ABSTRACT <b>unclassified</b>	c. THIS PAGE <b>unclassified</b>	<b>UU</b>
			18. NUMBER OF PAGES <b>46</b>
			19a. NAME OF RESPONSIBLE PERSON

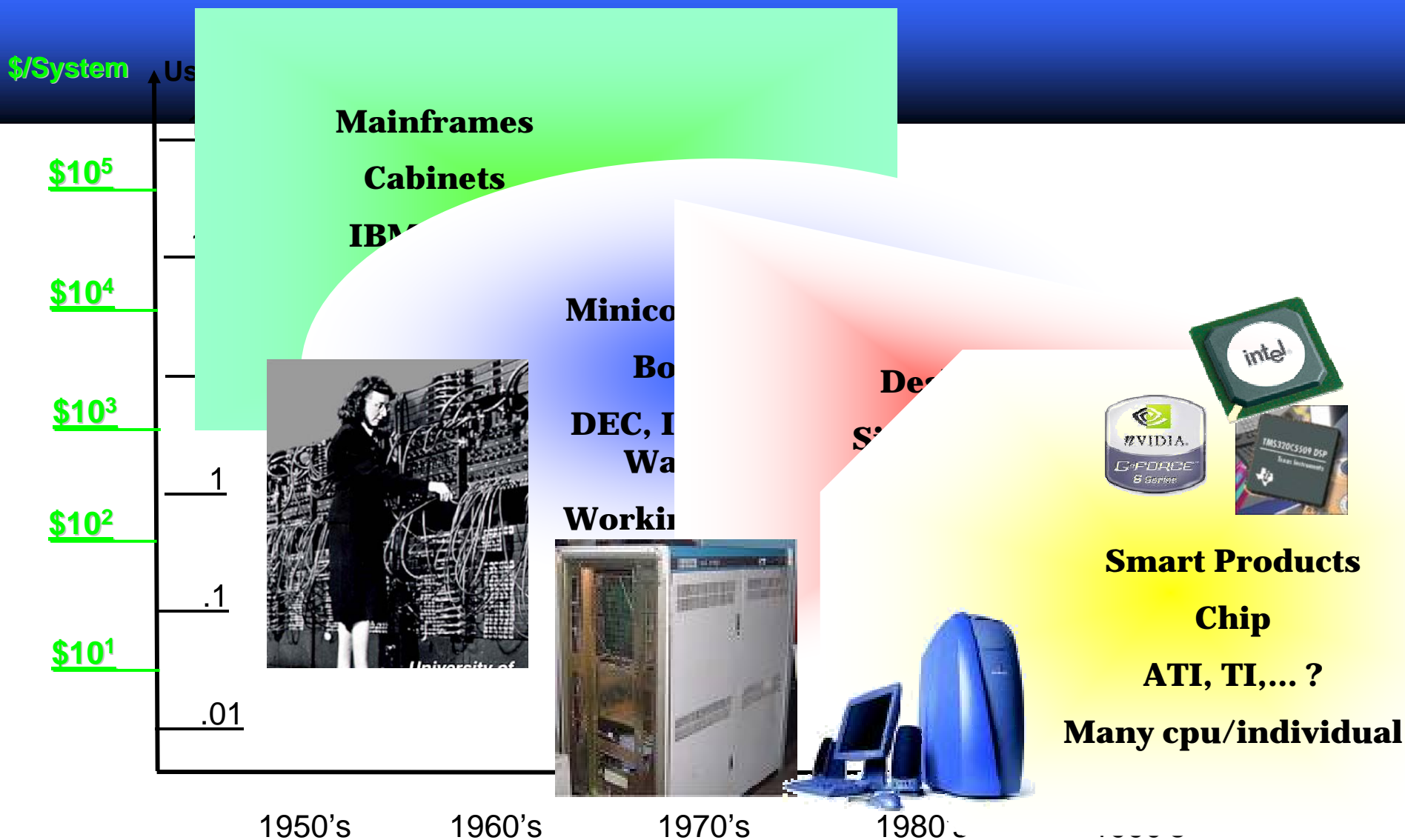

**In DARPA's lifetime the user/cpu ratio has inverted**



# DARPA Director Lauds Winning Embedded Processing Solution to DARPA Grand Challenge

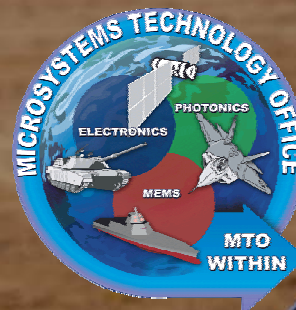
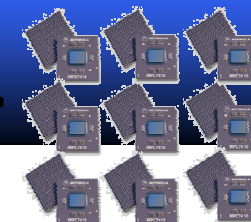

Photo courtesy of DARPA

- GC1: Embedded DSP Algorithms Mapping to non-traditional commodity architectures



- GC2: Co-Design of Algorithms and Architecture  
Towards Commodity Nonlinear DSP

$$y(n) = \sum_{p=0}^P \sum_{n_1=0}^N \cdots \sum_{n_p=0}^N H_p(n_1, \dots, n_p) x(n-n_1) \cdots x(n-n_p)$$

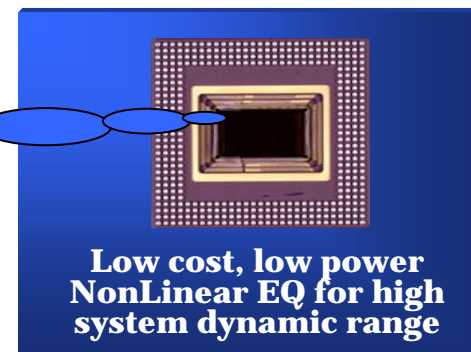

- GC3: Integrated Sensing with Processing
  - System level Co-design: Sensor/Processor/Algorithms
  - “compressed” sensing/processing

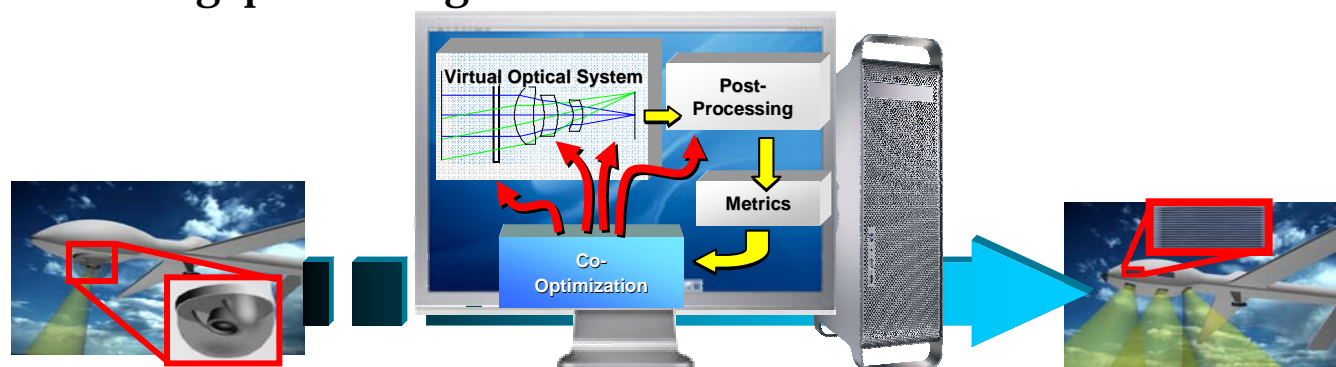



# PROCESSING GRAND CHALLENGE 1

## EO/IR Space Time Adaptive Processing (STAP)



### Current airborne Advanced EO/IR System

1 m resol'n over 1km<sup>2</sup>

0.25 Mpixel @ 10 Hz

IR-STAP track before detect

Small targets in clutter



Figure 6-7. P2J128J CE Daughtercard (Heat Sinks Removed)

- real-time 4 PPC 7410 500 MHz processors, close to 4.93 GFLOPS
- 512 X 512 IR images at 2 Hz rate, 36 target velocity hypotheses

To move beyond TIVO in the sky:

Need TeraFlops Scale Embedded Processor

25,600 windows

5 x 5 x 5 matched filter

10 target models

10 second update

10,000 targets

### Upcoming Systems

- 100 Mpixels @ 2 Hz

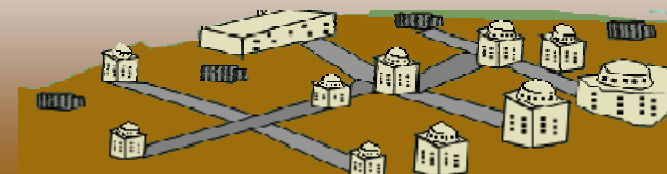

## Gaming hardware/software explosion

- *Optimized for complex geometric forward problems*
- Big Market – fastest growing commercial I.T. drives
  - Increased capability, programmability
  - Towards portable form factor, power
  - Open standards for rapid software development

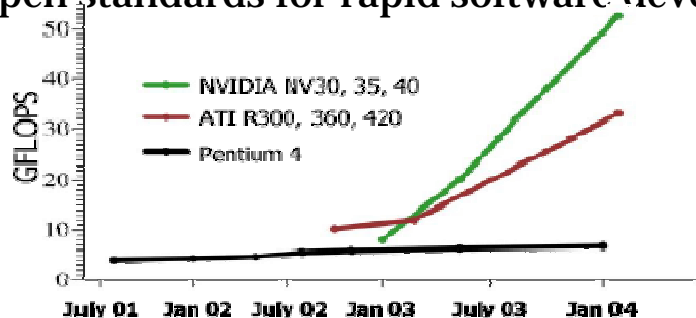

## DoD Sensor processing challenges

- *Complex geometric inverse problems*
- Form Factor Limitations
- Curse of the small market
  - Hardware \$\$
  - Software \$\$\$\$

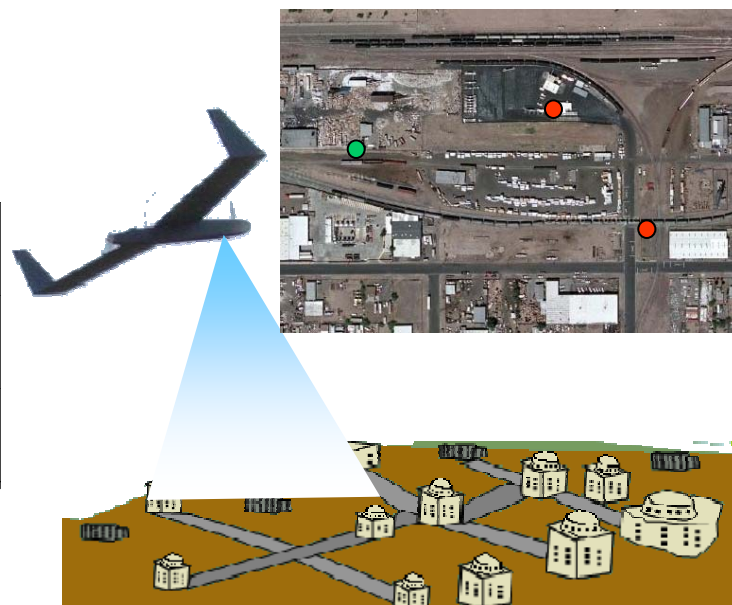
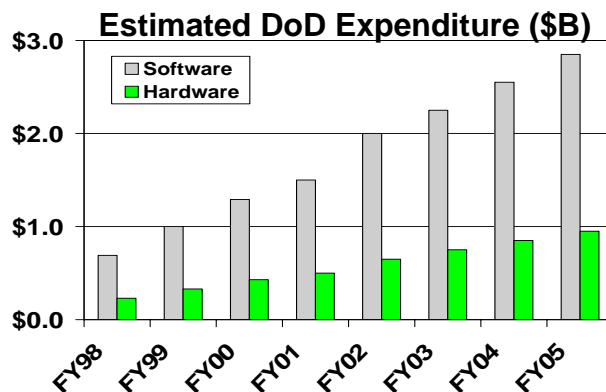

# STAP-BOY

(STAP = Space-Time Adaptive Processing)



$$w = \Lambda^{-1}S$$

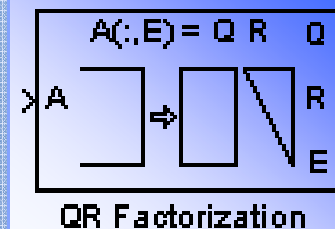

Low Cost Te Processor Architecture algorithms  
 from Gaming Geometry-based concepts



- Algorithm Mapping (for algebra) to Geometry
- 3D Pipeline Mesh Scalable Architecture  
 1 COTS Graphics Processor Unit (GPU)
- Transition to Low Power Handheld Computing for Disruptive  
 >50 GFLOPs
- > 10 AltiVec Power PC DSPs  
 2.5 GFLOPs



# Phase I in Perspective: STAP-BOY in "The Embedded Sensor Processor Trade Space"



Badness



AMD server  
120 W ~.8k\$

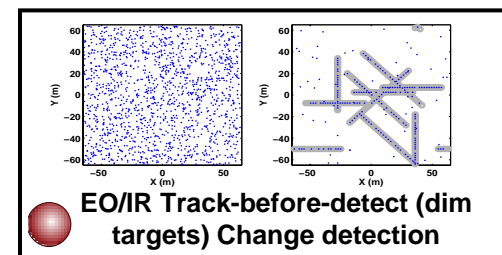
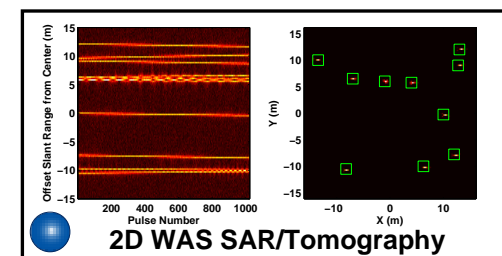
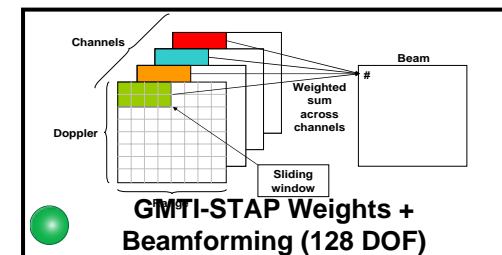
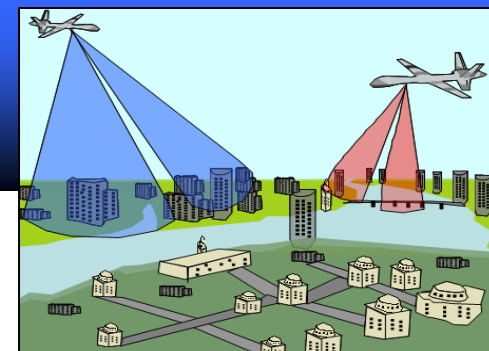
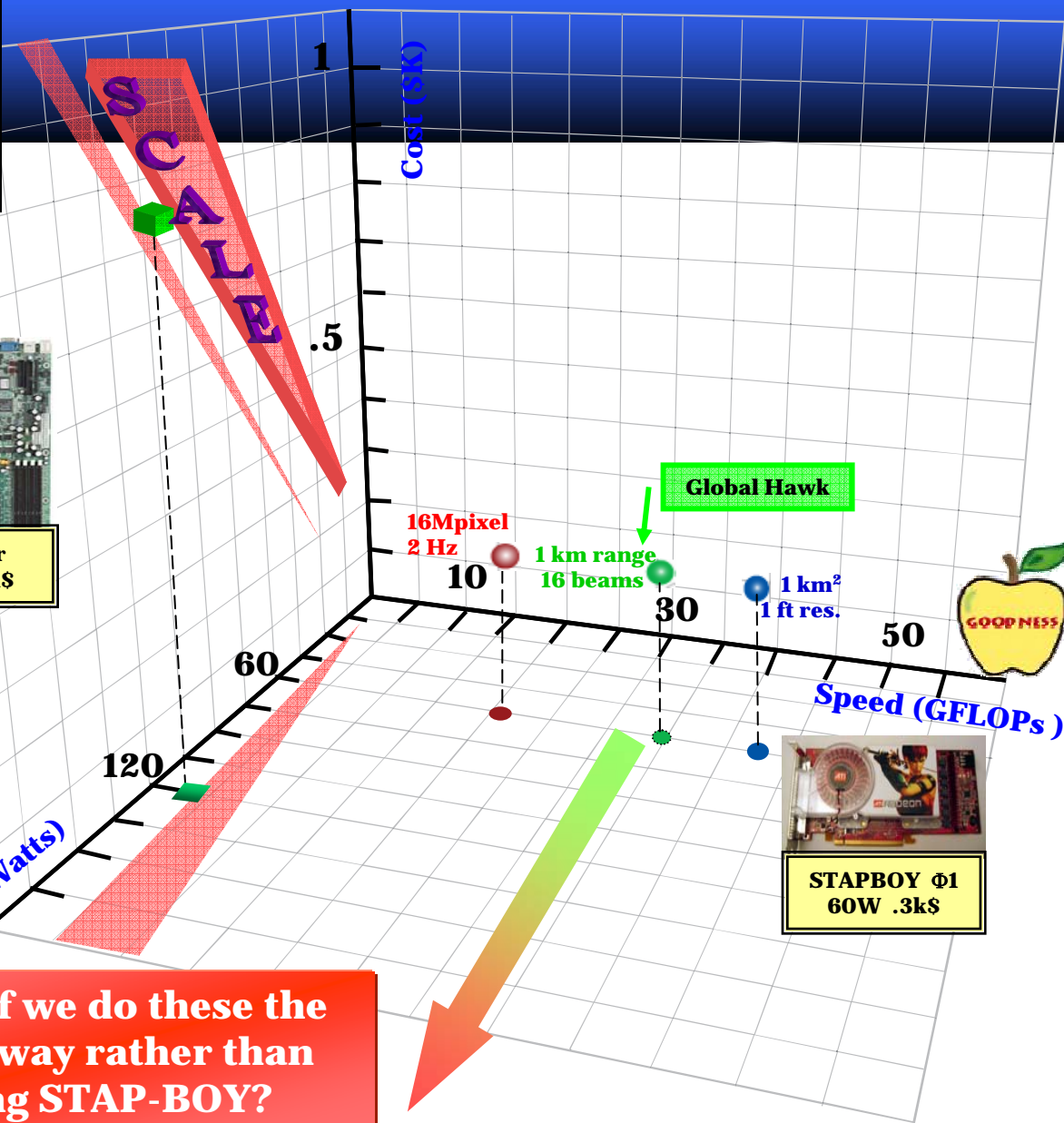

What if we do these the usual way rather than using STAP-BOY?



# Phase I in Perspective: STAP-BOY in "The Embedded Sensor Processor Trade Space"



Badness

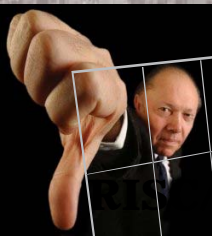

DSP

SCALE  
SCALE  
SCALE



AMD server  
120 W ~.8k\$



STAPBOY O1  
60W .3k\$

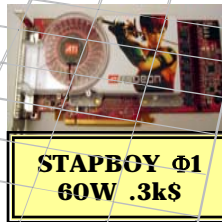

STAPBOY O1  
60W .3k\$

ixel  
0  
1 km range  
16 beams

Global Hawk  
MPRTIP

1 km<sup>2</sup>  
1 ft res.

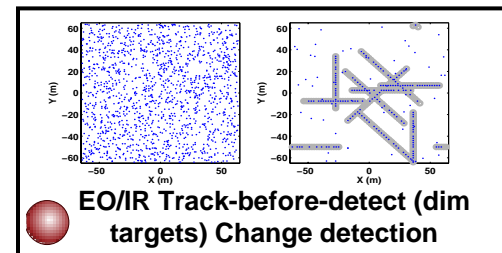
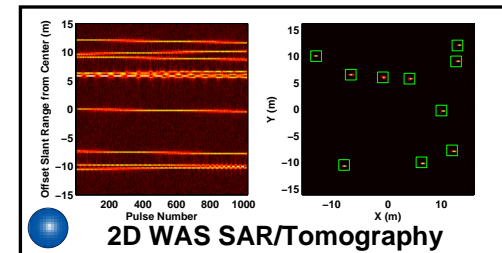
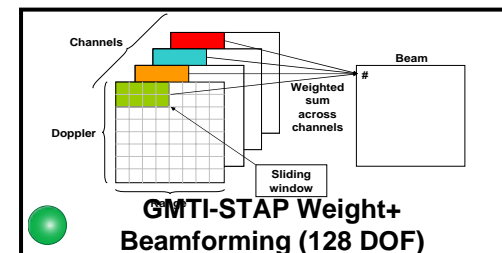
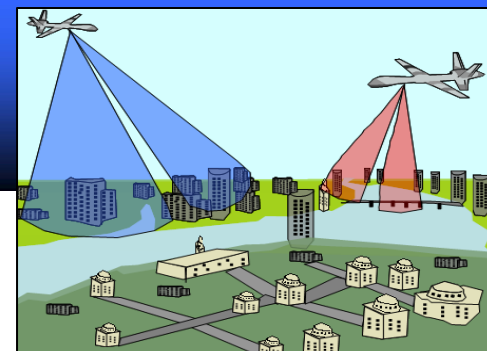

What if we do these the usual way rather than using STAP-BOY?

# Phase I in Perspective: STAP-BOY in "The Embedded Sensor Processor Trade Space"

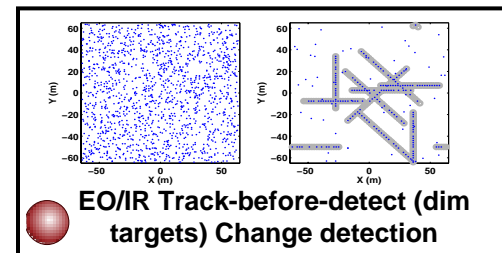
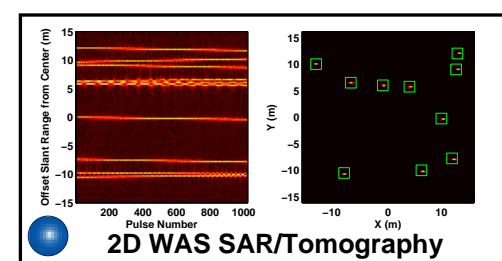
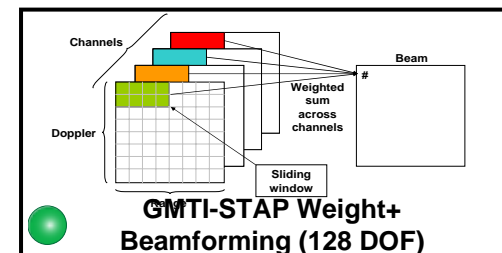
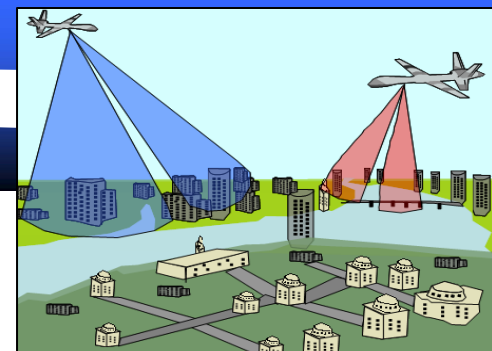
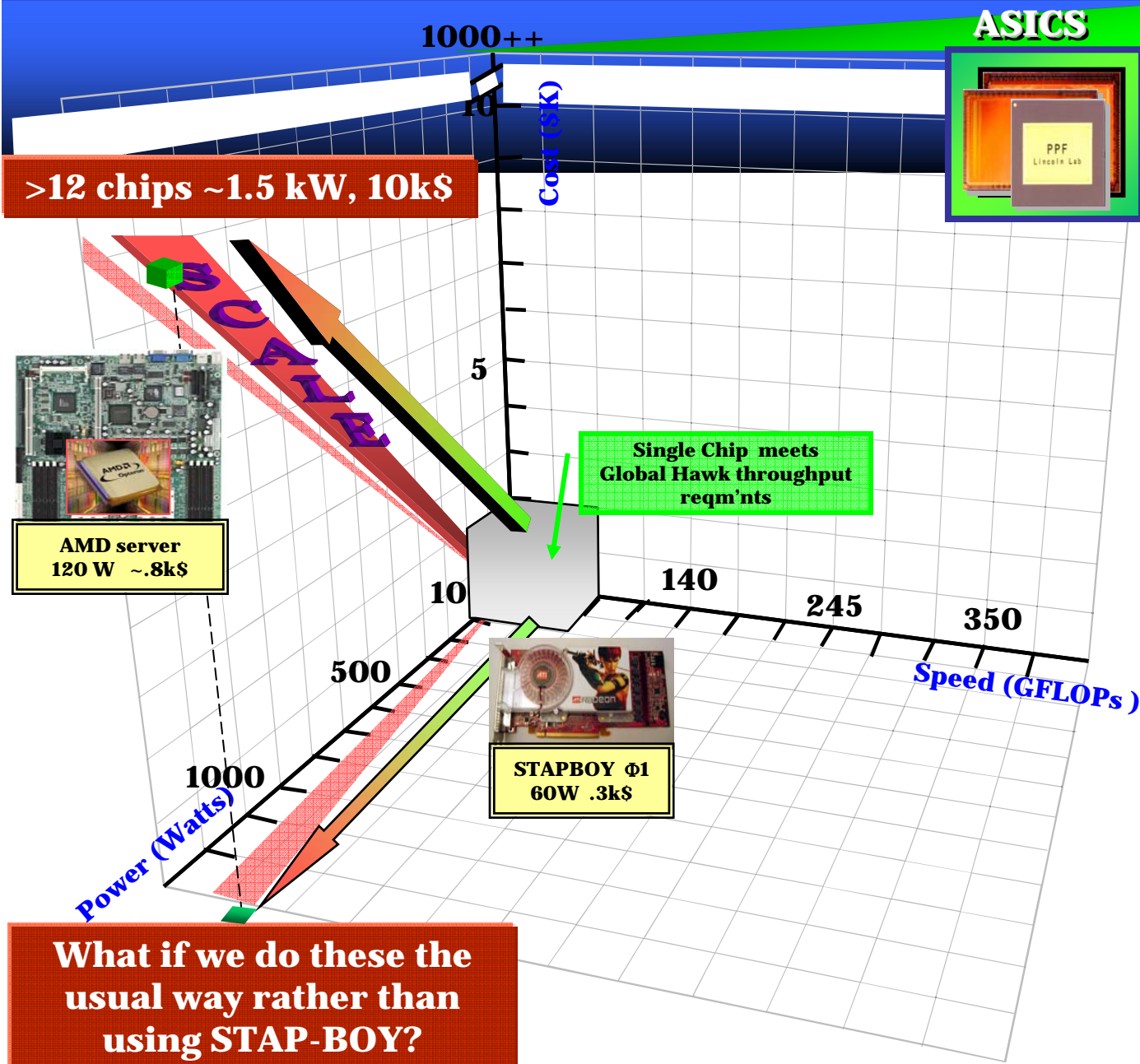

**What if we do these the usual way rather than using STAP-BOY?**



# Phase 2: Can we scale the *STAP-BOY* low cost low power hardware and software to required system performance?

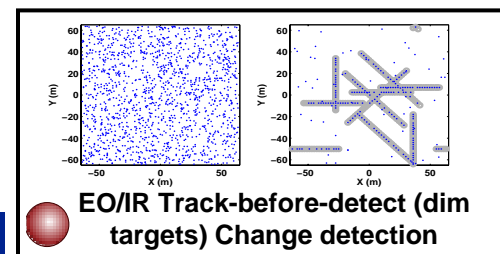
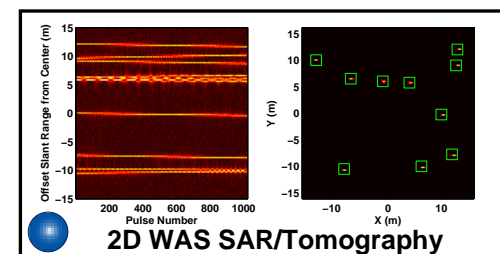
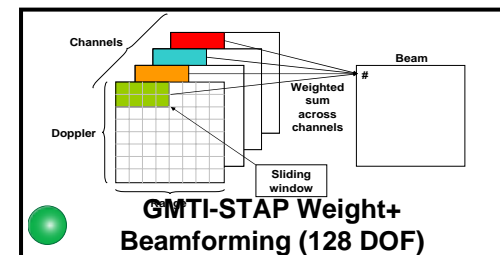
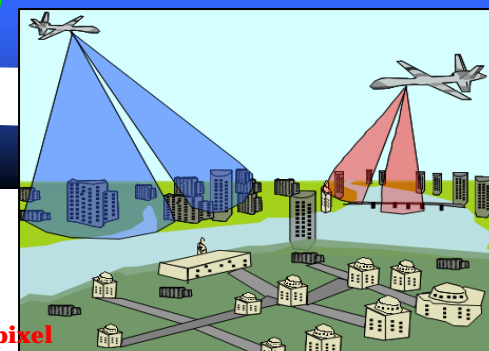
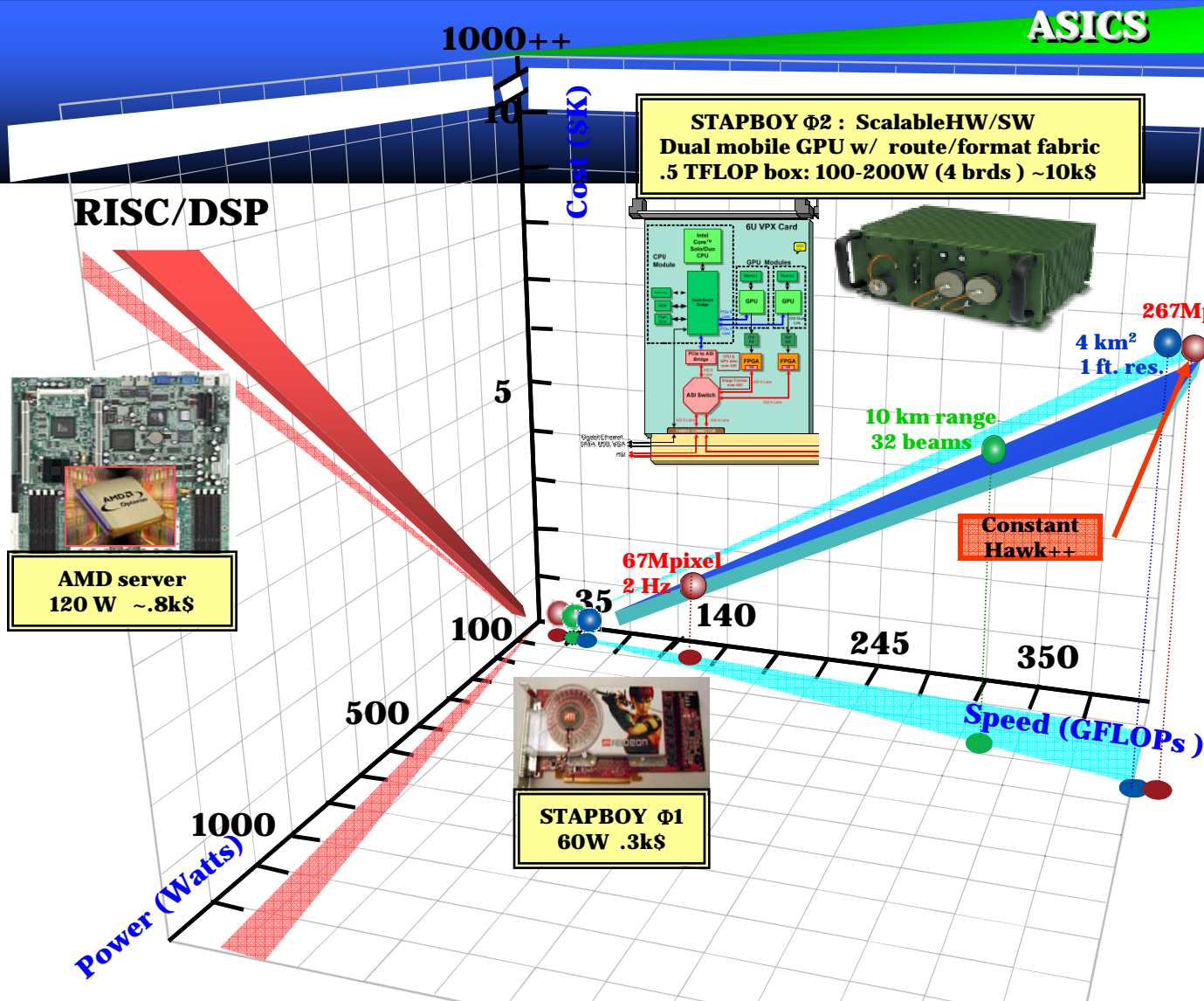

**Next Challenge:**  
Advancing Sensor Resolution Drives Processing Well Beyond CPU/DSP and ASIC Envelopes for Cost & Comms Constrained Platforms

# PROCESSING GRAND CHALLENGE 2

## Getting a clear view through the RF front end

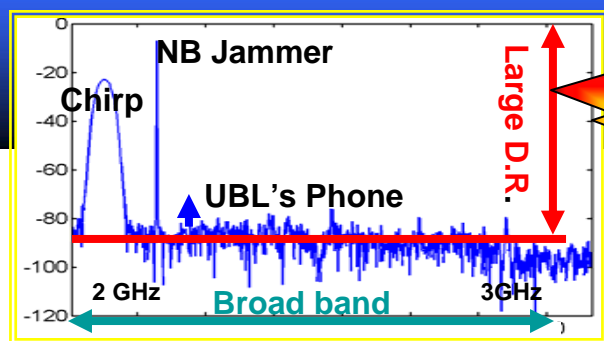

*Complex RF environment*

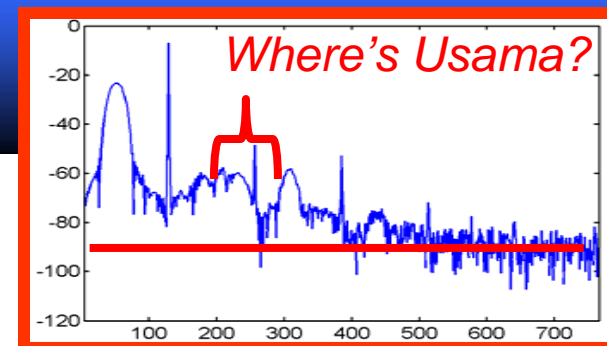
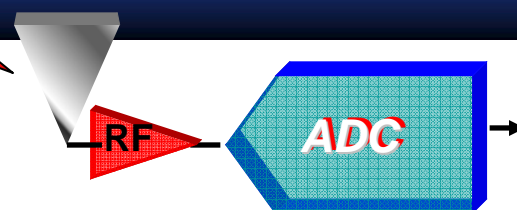

*Distorted digital Representation*

**Rapid Proliferation of LPI: UWB, spread, hopped, coded...**

**Digital Receivers not keeping up**

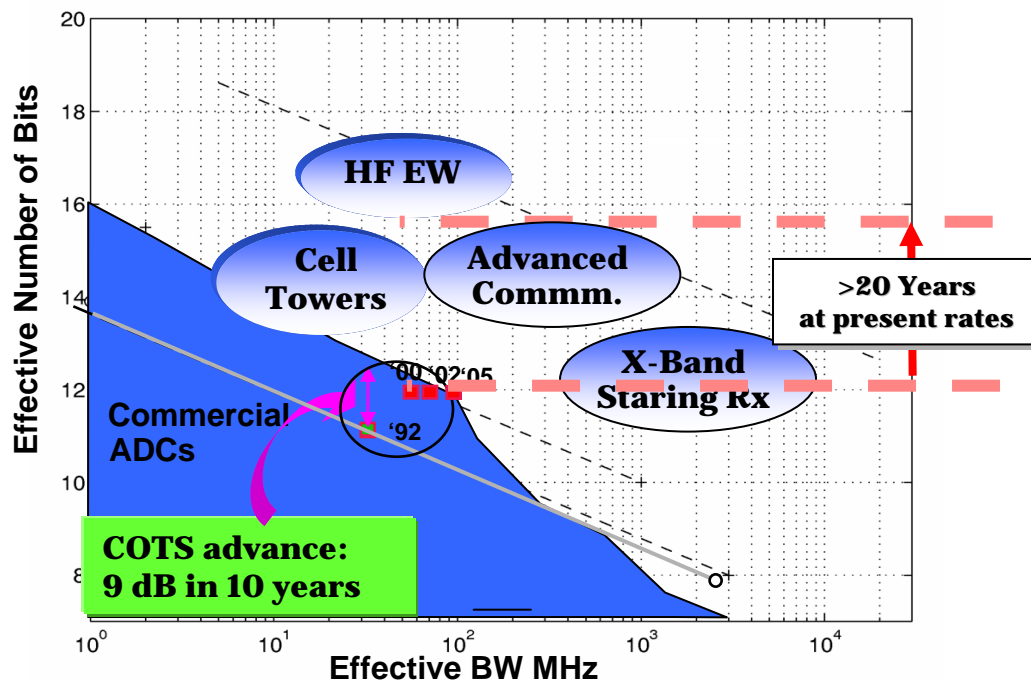

**Attacking this problem through a revolution in nonlinear digital signal processing**



# Co-Designed Nonlinear Equalization (NLEQ) Advanced Signal Processing for Enhanced Dynamic Range

**Program Goal**  
+ 25 dB IFDR  
@500MHz IBW  
< 5 Watts  
in real time

## Representative System

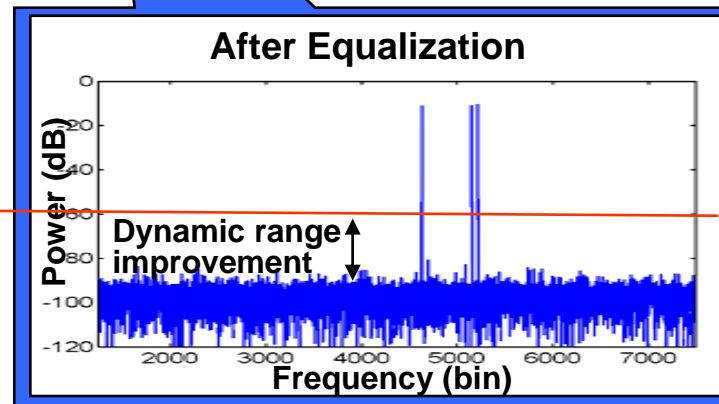
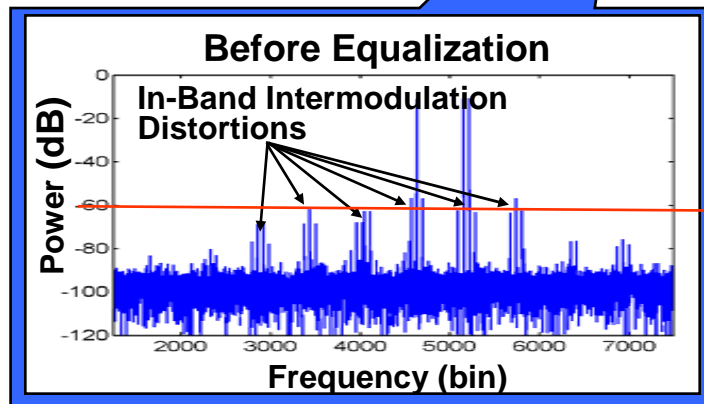
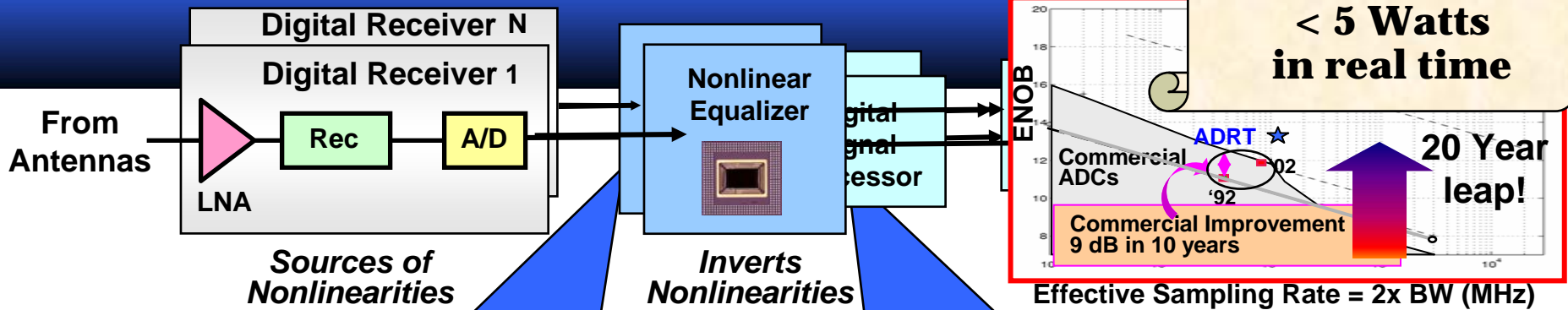

**Objective:** Overcome sensor device performance and cost limitations by **VLSI implementation of advanced nonlinear algorithms**

**Key Issues:** The Curse of Dimensionality  

- Computational Burden of NLEQ
- Training Cost of NLEQ

**Approach:** **Compressed Representations. Algorithm/Hardware co-design**

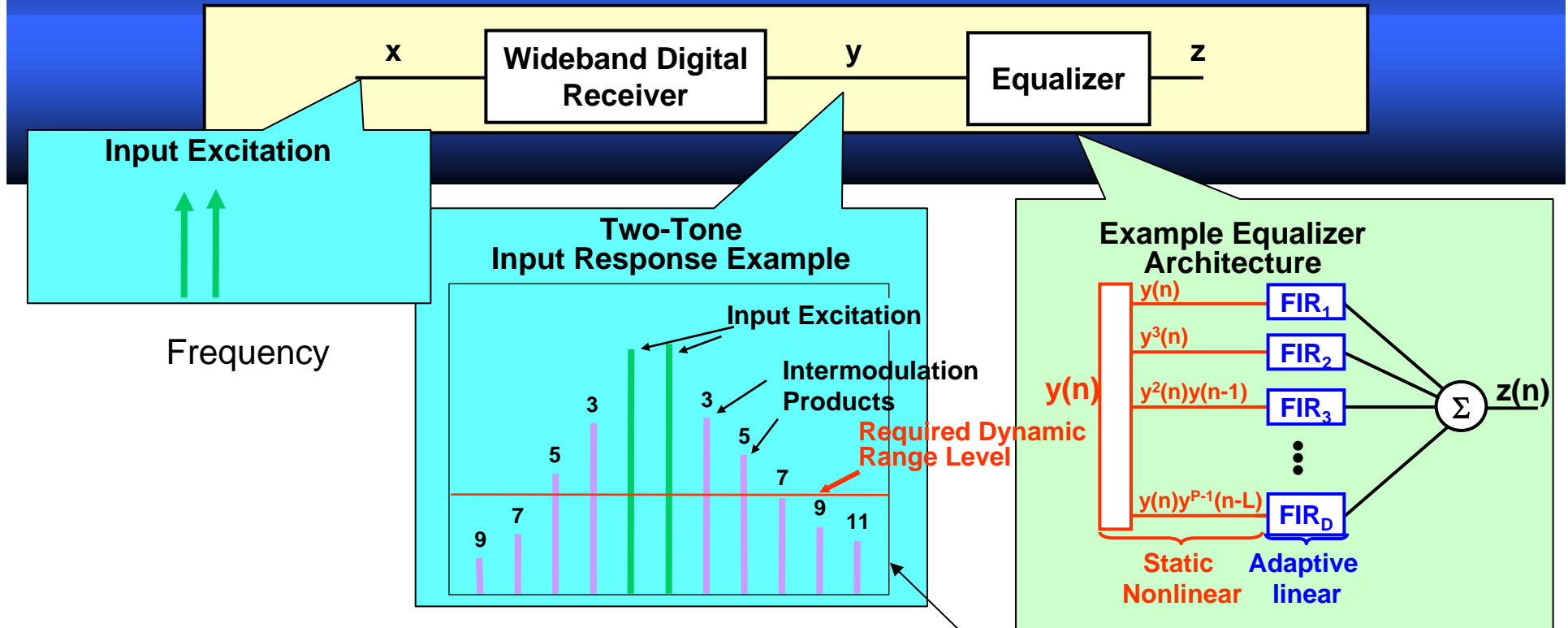

$$y(n) = \sum_{p=0}^P y_p(n) = \sum_{p=0}^P \sum_{n_1=0}^N \cdots \sum_{n_p}^N C_p(n_1, \dots, n_p) x(n - n_1) \cdots x(n - n_p)$$

- Generalization of Taylor series (N=0)
- Generalization of linear FIR filter (P=1)
- Naively, size scales as  $N^P$  for memory N and nonlinear order P
- Training NLEQ looks like a high-d optimization problem

## NonLinear Equalizer Algorithm/Architecture\*

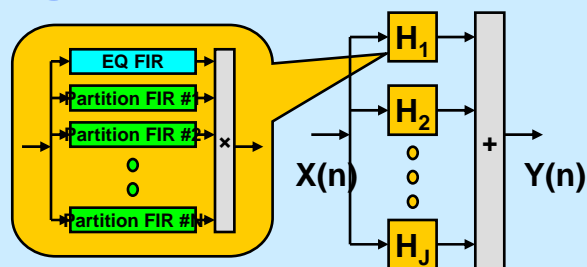

PHoCS Compressed Nonlinear representation

Distributed Polyphase Block-Floating-Point Residue Arithmetic Architecture

500 - 2000 OPS/Sample

25,000 – 100,000 Low-Power Multipliers

20,000 – 80,000 Accumulators

## IC Architecture and Floor Plan\*

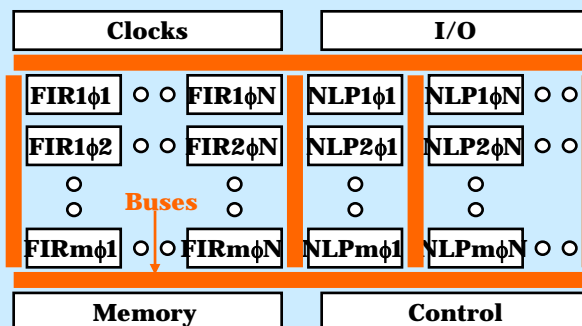

Systolic architecture minimizes high-speed comm. path lengths

High clock rate processing across entire die area

Two Input Ports, Two Output  
750 MSPS Demultiplexed  
1500 MSPS Full Rate

Control

## Processor Die

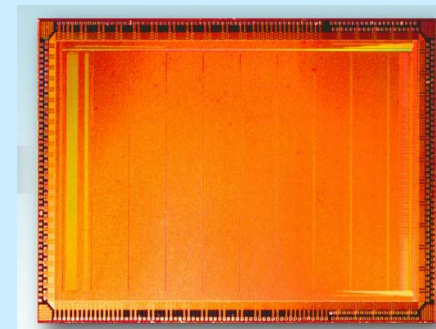

0.09 - 0.13 Micron CMOS

30M - 100M Devices

2 - 4 cm<sup>2</sup> Die Area

Low-Power Low-Vt Dynamic Logic

~1TOPS, <3 Watts

Low-power LVDS compatible I/O drivers

## Pentium 4 die

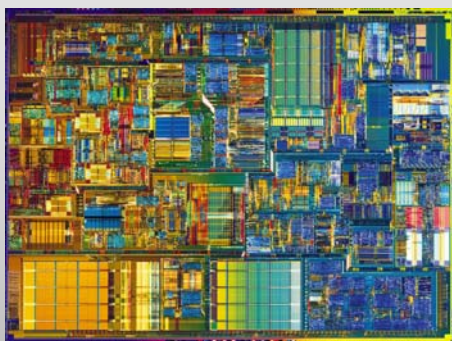

- 1300 dies required for 1 Teraops NLEQ
  - 150 KW total power
- Assumptions for each die
  - 3.8 GHz
  - 115 Watts
  - 10% code efficiency

## Phase 2 NLEQ DSP Die

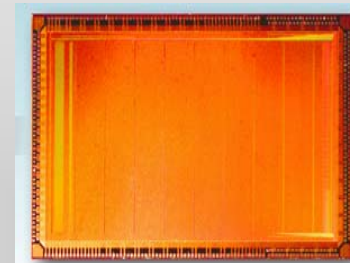

- 1 die required for 1 Teraops NLEQ
  - <5 W total power
- 50,000x power efficiency
- 1,300x computational throughput density
- 65,000,000x total figure of merit of computational density times power efficiency

$$y(n) = \sum_{p=0}^P \sum_{n_1=0}^N \dots \sum_{n_p=0}^N H_p(n_1, \dots, n_p) x(n-n_1) \dots x(n-n_p)$$

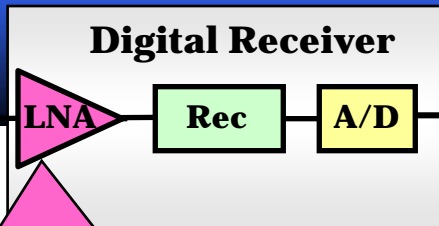

Low cost, low power digital NLEQ provides necessary high system dynamic range

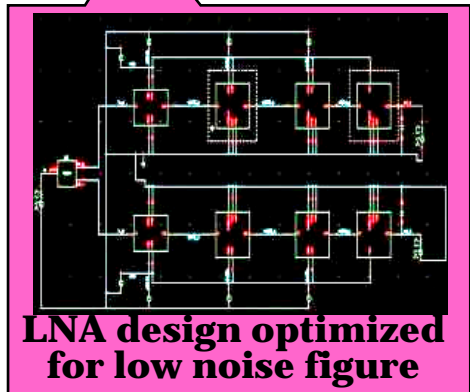

Current circuit designs can be costly when optimizing both low noise *and* high dynamic range

## S-Band Receiver and ADC (10-MHz Bandwidth)

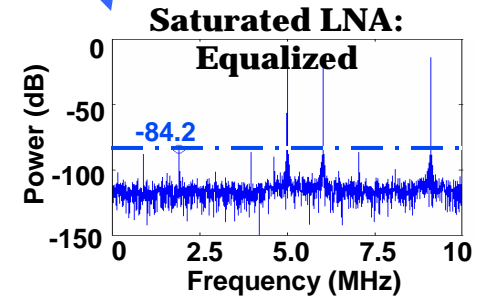
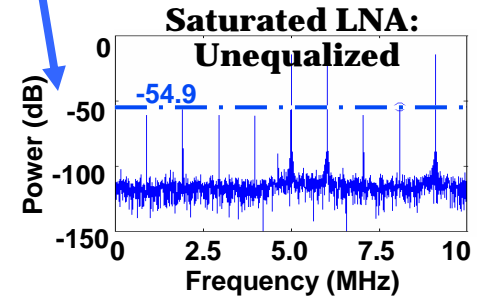

## ADC Only (10-MHz Bandwidth)

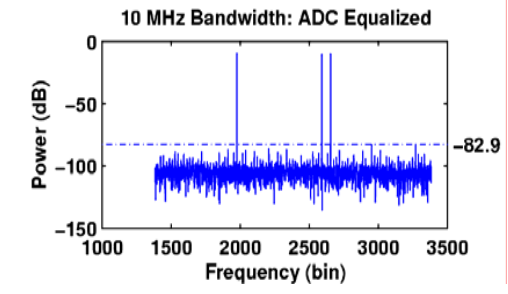
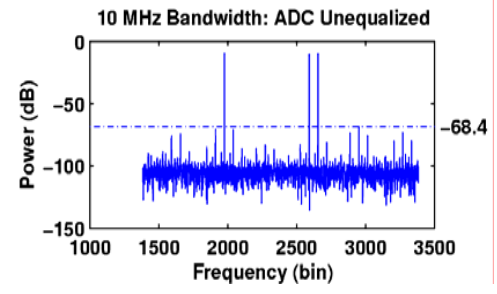

**Embedded Non Linear Signal Processing simplifies circuit designs if used early in the design process**

# Brains and bodies evolved together

- Embedded processing is optimized for the needs of the system, say a sensor system like a camera. Why can't the camera be optimized for the processing?  
*“Cameras will also change form. Today, they are basically **film cameras without the film**, which makes about as much sense as automobiles circa 1910, which were **horse-drawn carriages without the horse**. A car owner of that time would be pretty shocked by what's in a showroom now. Camera stores of the future will surprise us just as much.” -Nathan Myhrvold, former CTO of Microsoft, co-founder of Intellectual Ventures, NY Times, 5 June 2006*



Nobody on board

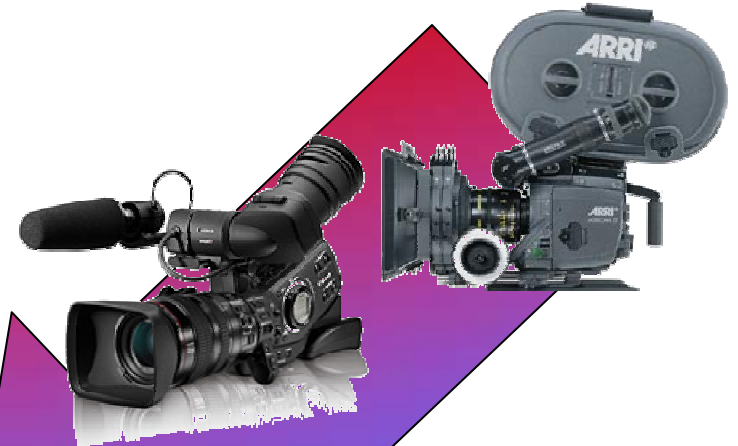
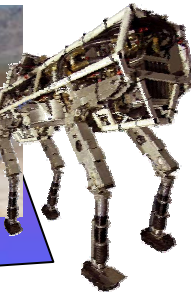

?

- Structural & functional impact of co-design over the *entire* system?

# Co-Design opens a new design space between Camera and Computed Imaging



**Optical Field Processing**



**RF Pixel Sampling**

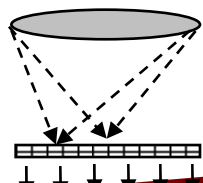

**Digital Pixel Processing**

**Image**

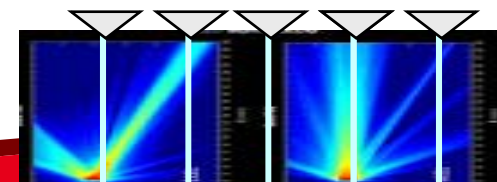

*Digital Beamformer RF Array*

**Digital Field Processing**

**Image**

# “Load Balancing” between Photon Processing and Bit Processing



**Optical Field Processing**

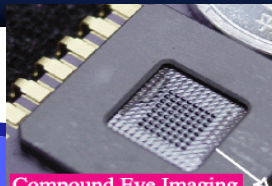

**Optical Regional Processing**



**RF Pixel Sampling**

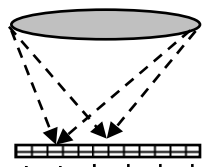

**Digital Pixel Processing**

**Image**

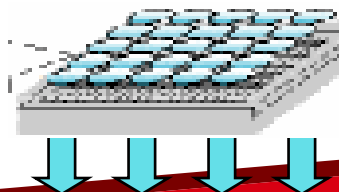

**Digital Regional Processing**

**Image**

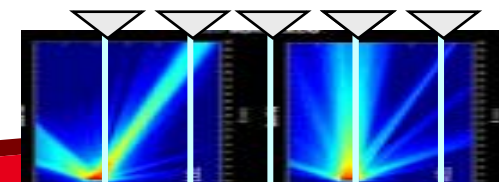

*Digital Beamformer RF Array*

**Digital Field Processing**

**Image**

# "Load Balancing" between Photon Processing and Bit Processing



Optical Field Processing

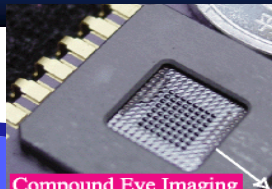

Optical Regional Processing

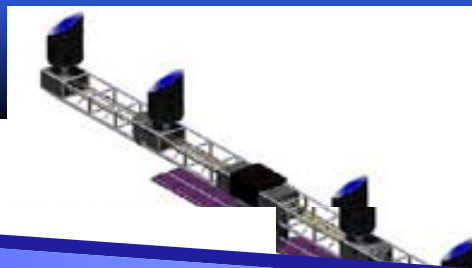

Optical Pixel Processing



RF Pixel Sampling

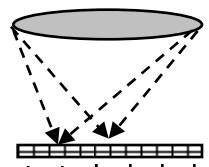

Digital Pixel Processing

Image

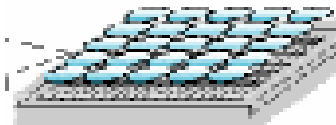

Digital Regional Processing

Image

Sampling Field Sensor

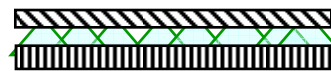

Digital Field Processing

Image

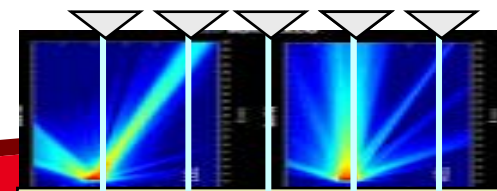

Digital Beamformer RF Array

Digital Field Processing

Image



Exploitation

# PROCESSING GRAND CHALLENGE 3

## Camera Ab Initio

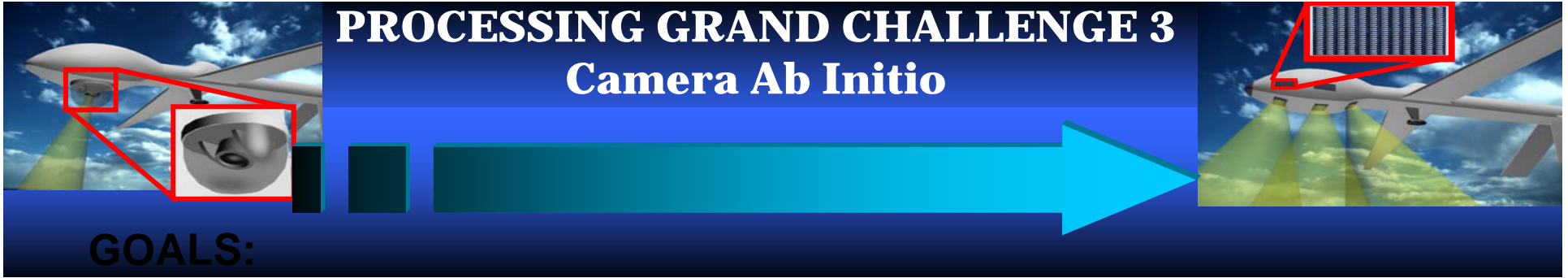

### GOALS:

- Radically transform form, fit and function of imaging sensors
- Integrated systems for transforming photons to information
- Simplified Manufacturing and Integration Process

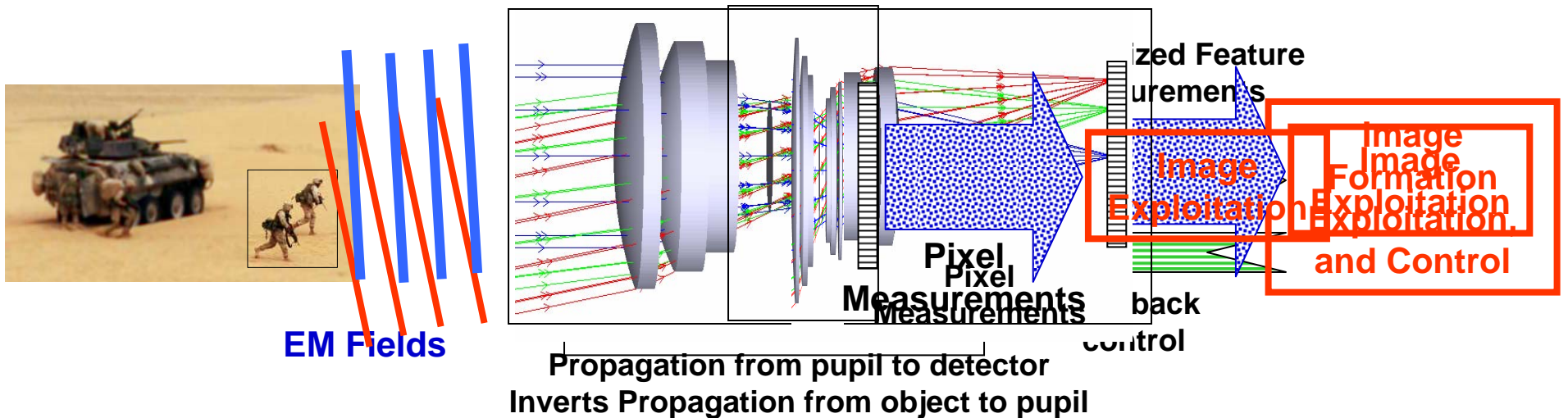

### APPROACH:

- Joint optimization of optics, sensors, post-processing algorithms
- Unconventional wavefront mapping (well conditioned encoding)
- Information-rich parameters for (compressive) measurement
- Integrated and simplified manufacturing approaches

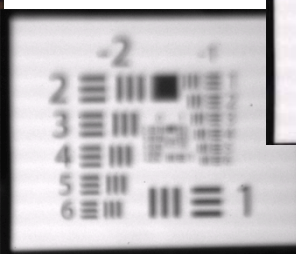
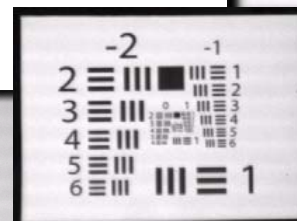
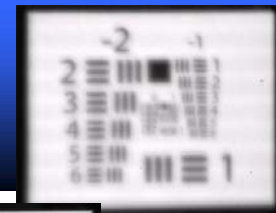

2.2m

In focus (2.6 m)

3m

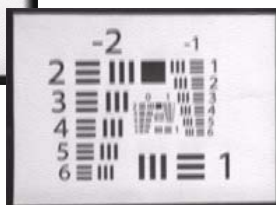

**Canon Powershot SD30**  
5 Megapixel compact camera, 120g

**Montage MDO "Nano"**  
2 Megapixel, **ultra**-compact camera 30g  
( $< 15$  g w/o metal housing)



Canon SD30

MontageNano

Optical track	~30mm	5mm
Light collection	$< 20\text{mm}^2$	$80\text{mm}^2$
Resolution (2.2m range)	~30 lp/mm	100 lp/mm
Focal length	6.3 – 14.9mm	43mm
Optics	Multi-element refractor	Single element folded reflector

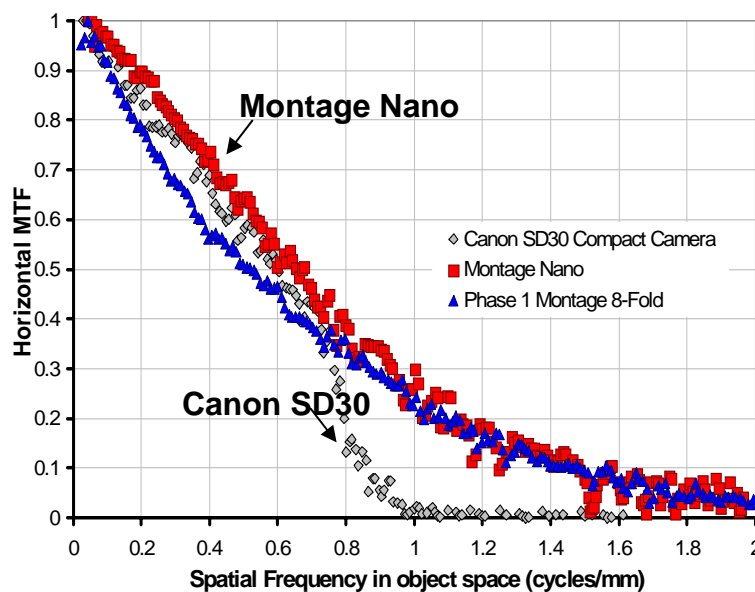

# Lenslet Array LWIR camera vs. SOA

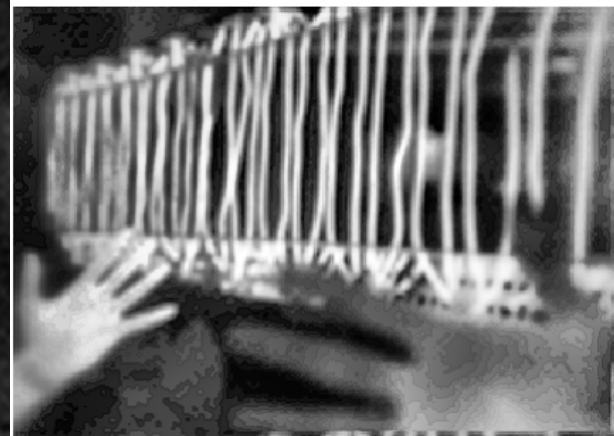
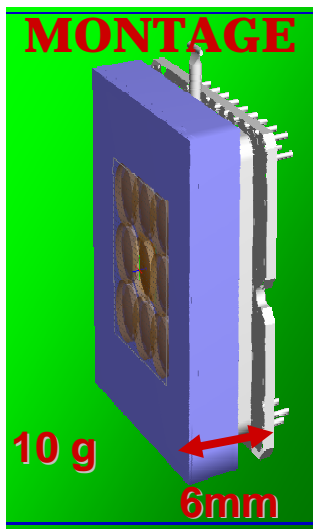
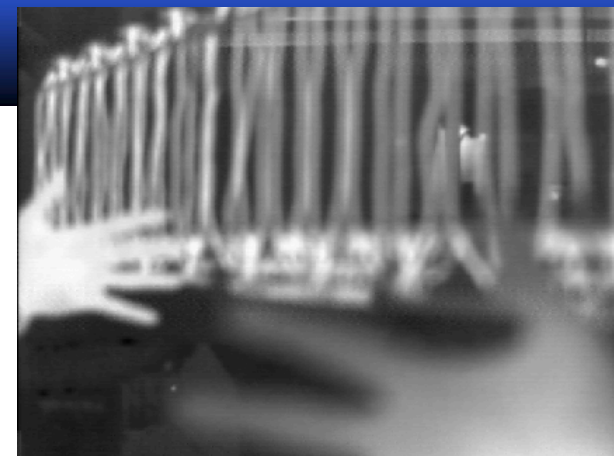
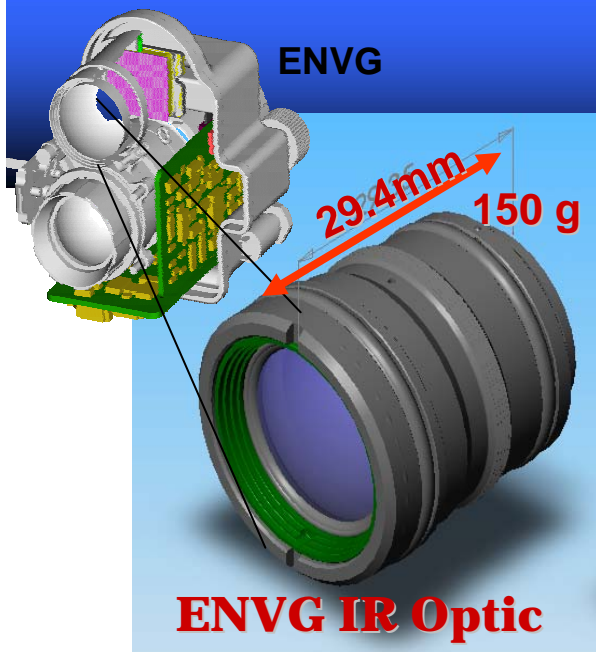

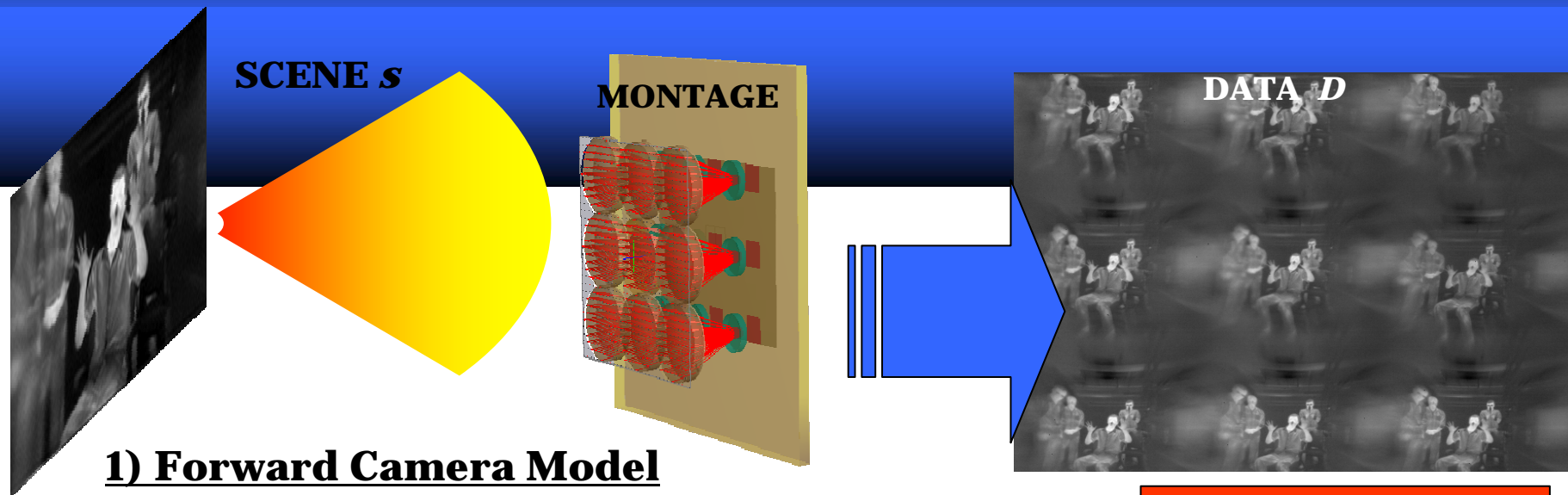

## 1) Forward Camera Model

Predicts camera data  $D$  produced by a given scene

## 2) Solve Imaging Inverse Problem

Given data, estimates scene that produced it

$$\hat{s} = \arg \min_{s \in S} \{ L(s; D) + P(s) \}$$

Discrepancy between observed Data  $D$  & Data the Camera Model predicts from  $s$

Penalty for unlikely or unphysical choices of  $s$

**Sparsity Regularized Inversion**



**Reconstructed Image**

**Innovations:** COMPRESSIVE ENCODING  
CO-DESIGN OF CAMERA & INVERSE ALGORITHM  
SPARSITY AS CONSTRAINT

# Exploiting Sparsity in Compressed Sensing/Processing

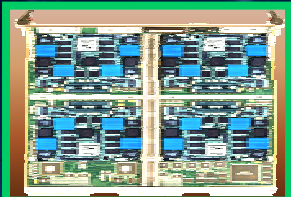

Compress: Compute hard, throw away 80% of the Megapixels for Downlink through tiny pipe

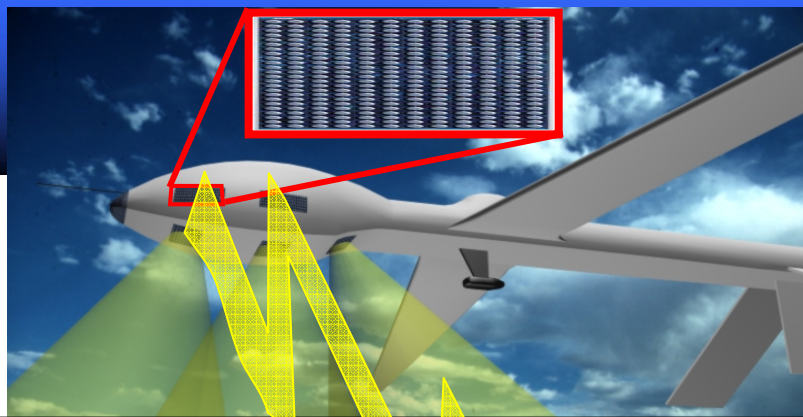

Compressed Camera *directly measures* Compressed representation for downlink

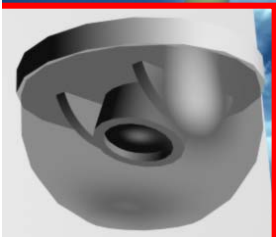

High Resolution Image : Big Optics, Megapixel Data

## ***Uncomfortable Observation:***

**Compressibility means most of the data in the megapixels is useless**

**BUT**

**The gold is hidden in a broad spatial bandwidth**

**Shannon: must measure the megapixels to capture the hidden gold then sieve it out with digital processing. Pessimistic!**

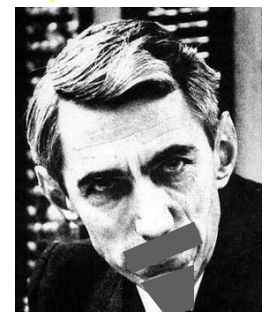

## **Compressive Sensing (Analog-to-Information):**

***Nonadaptive* Measurement at 20% of Megapixel rate gets the gold**

**Simpler Sensor. No Digital Compression on the platform.**



# Power to the Processors (right on!)

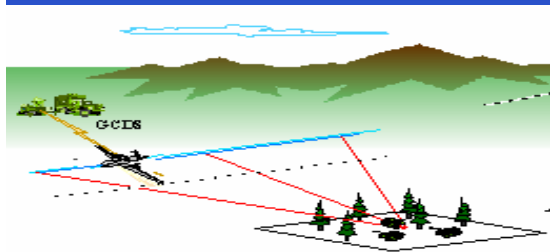

Photo courtesy of DARPA



**Fin**





Physical Field  
(continuum)

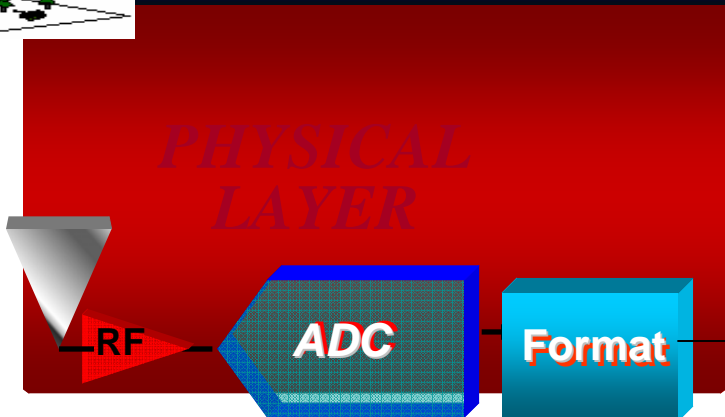
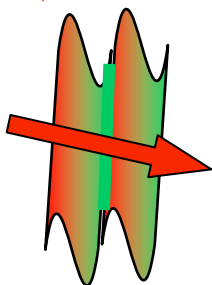

Digital Representation  
(Formatted)

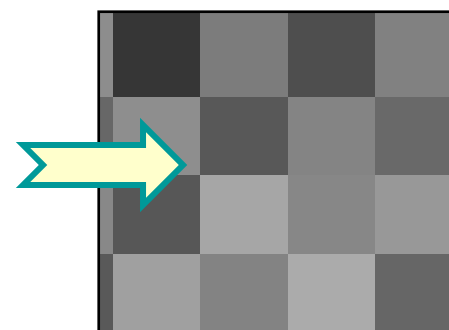

*Raw sensor data:*

*Huge Volume  
low information/sample  
Curse of Dimensionality*

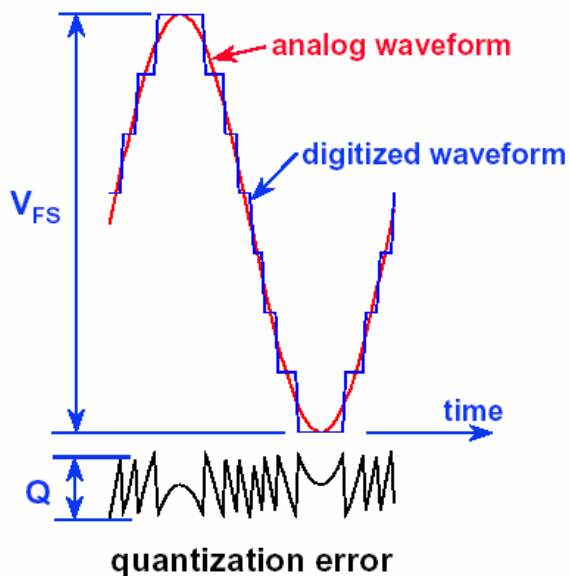



...is just the first link in a chain

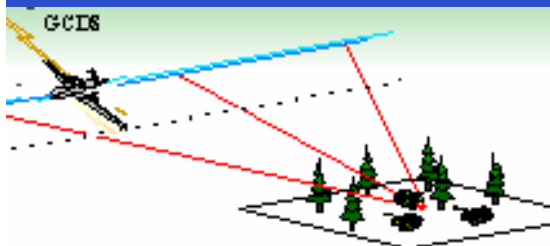

**Physical Field**  
(continuum)

**Digital Representation**  
(finite precision finite dimensional)

**Transformed**  
**Digital Representation**

**Symbolic Output**

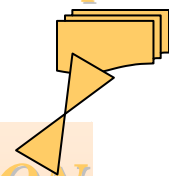
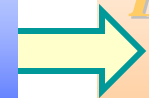
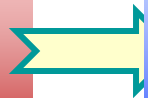
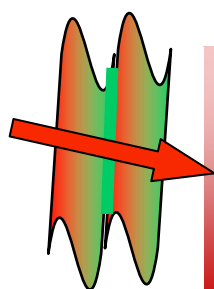

*Raw sensor data:*  
*low information/dimension*

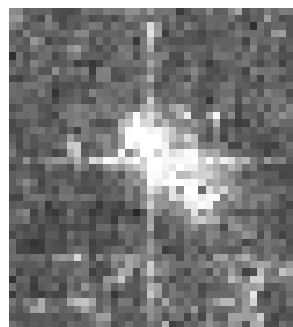

*Enhanced feature data:*  
*more information/dimension*

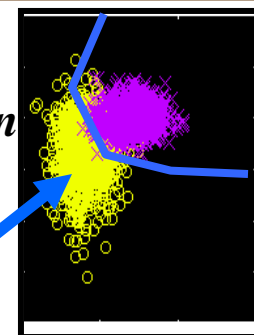
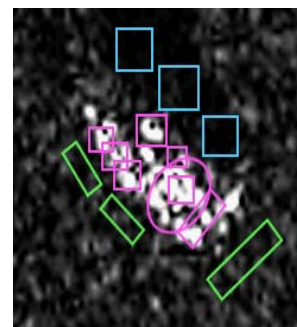

**Sensor: Work hard in the physical layer to measure everything at the highest fidelity**  
**Processor: Work hard to throw away most of that data to get at the "good stuff"**

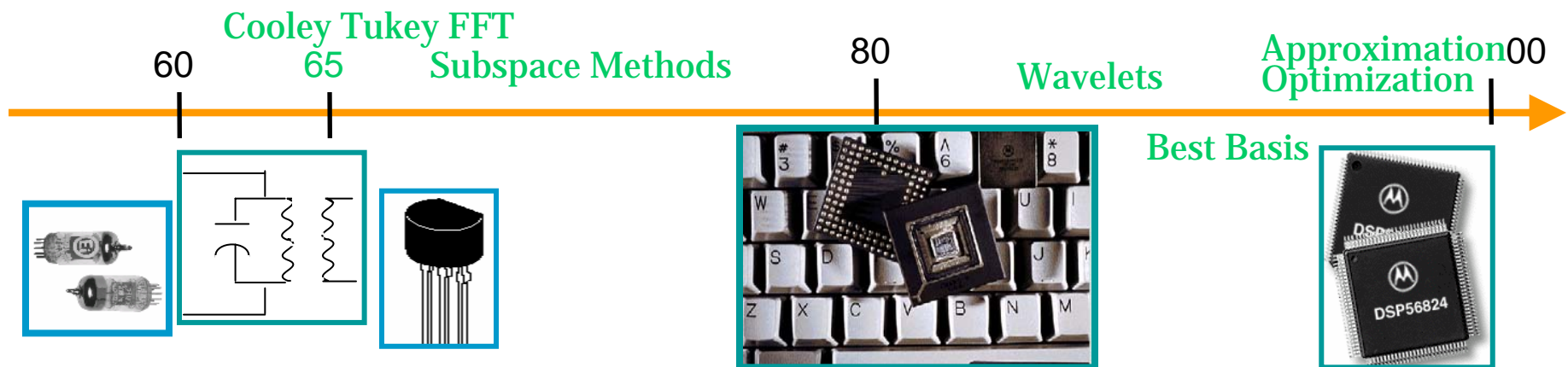
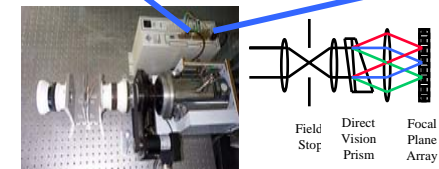
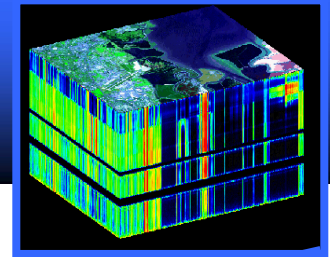
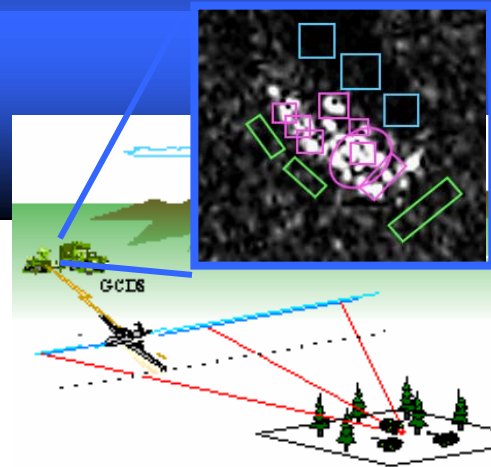
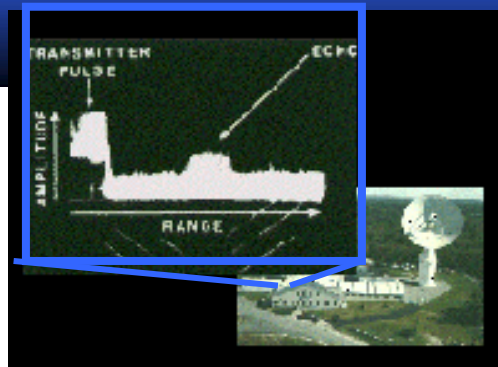

- *Increased complexity, dimensionality of sensing and exploitation tasks*
- *Decoupling of Digital and Analog subsystems, independently designed and optimized*
- *Steady Moore's Law growth of digital throughput (integration growth path)*
- *Equal impact of fast algorithms (representations), but sporadic, unpredictable*

Physical Field  
(continuum)

Digital Representation  
(finite precision finite dimensional)

Transformed  
Digital Representation

Symbolic Output

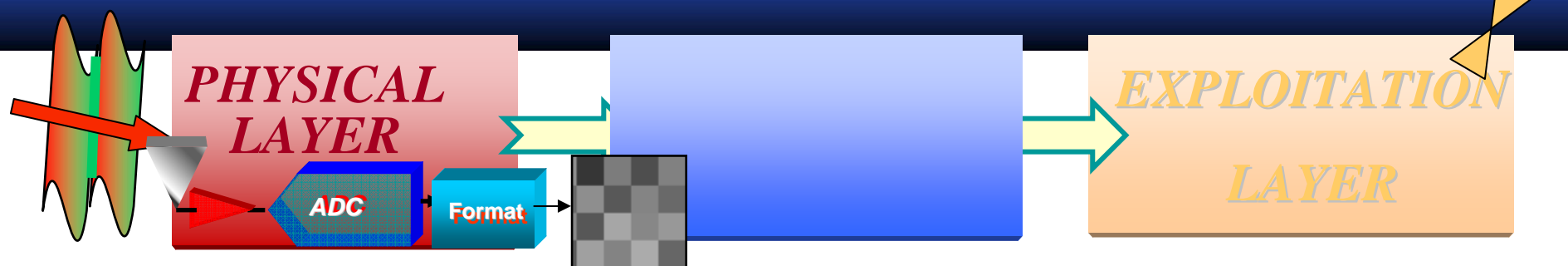

## Keep trying to measure/digitize everything at highest possible resolution?

- A No-brainer
- No-brainer! Maybe not always true!
  - Slow, expensive growth rate of resolution in A/D's
  - Curse of dimensionality: shouldn't do it even if you could!
- What might be better?
  - Dedicate Front end resources to measuring more of the “good stuff”
  - Sensing “features” at front end could reduce load on A/D and subsequent digital processing and exploitation.
  - If done properly, overall system performance can be improved even with the lower requirements on subsequent digital processing
- **Problem: the “smarts” for finding the “good stuff” are behind the ADC!**

Today's Sensor Systems are typically feed-forward networks for transforming information in specialized stages.

Dimension reduction is mainly applied at the back of the bus

Physical Field  
(continuum)

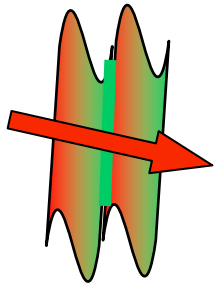

Digital Representation  
(finite precision  
finite dimensional)



Transformed  
Digital Representation



Symbolic Output

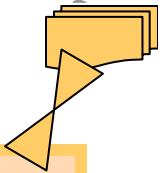

*Raw sensor data:  
low information/dimension*

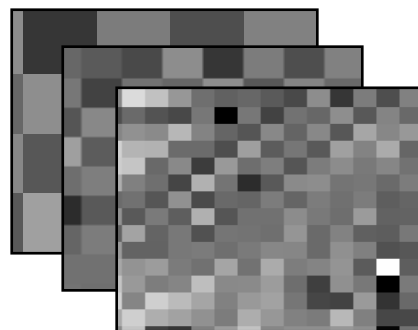

*DSP produces data reps with  
higher information/dimension*



*Fast approximate  
solution of a high  
dimensional non  
linear optimization  
problem*

## Meeting the Challenges: *Integrated Optimization of the System*

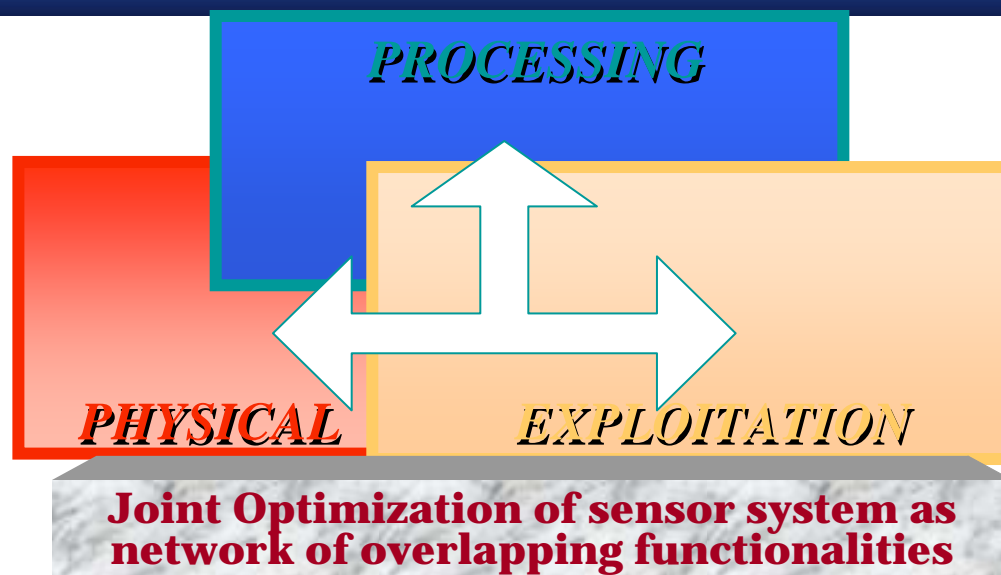

*Components will have overlapping and dynamically reconfigurable roles and full network connectivity. (**LOAD BALANCING**)*

*Make “customized” measurements at physical layer under real-time feedback control from the exploitation and processing system. **“20 Questions”***

*Manage/Prioritize **data** stream to affordable levels without discarding needed **information***

If that's not bad enough, we are building an internet of the damn things....

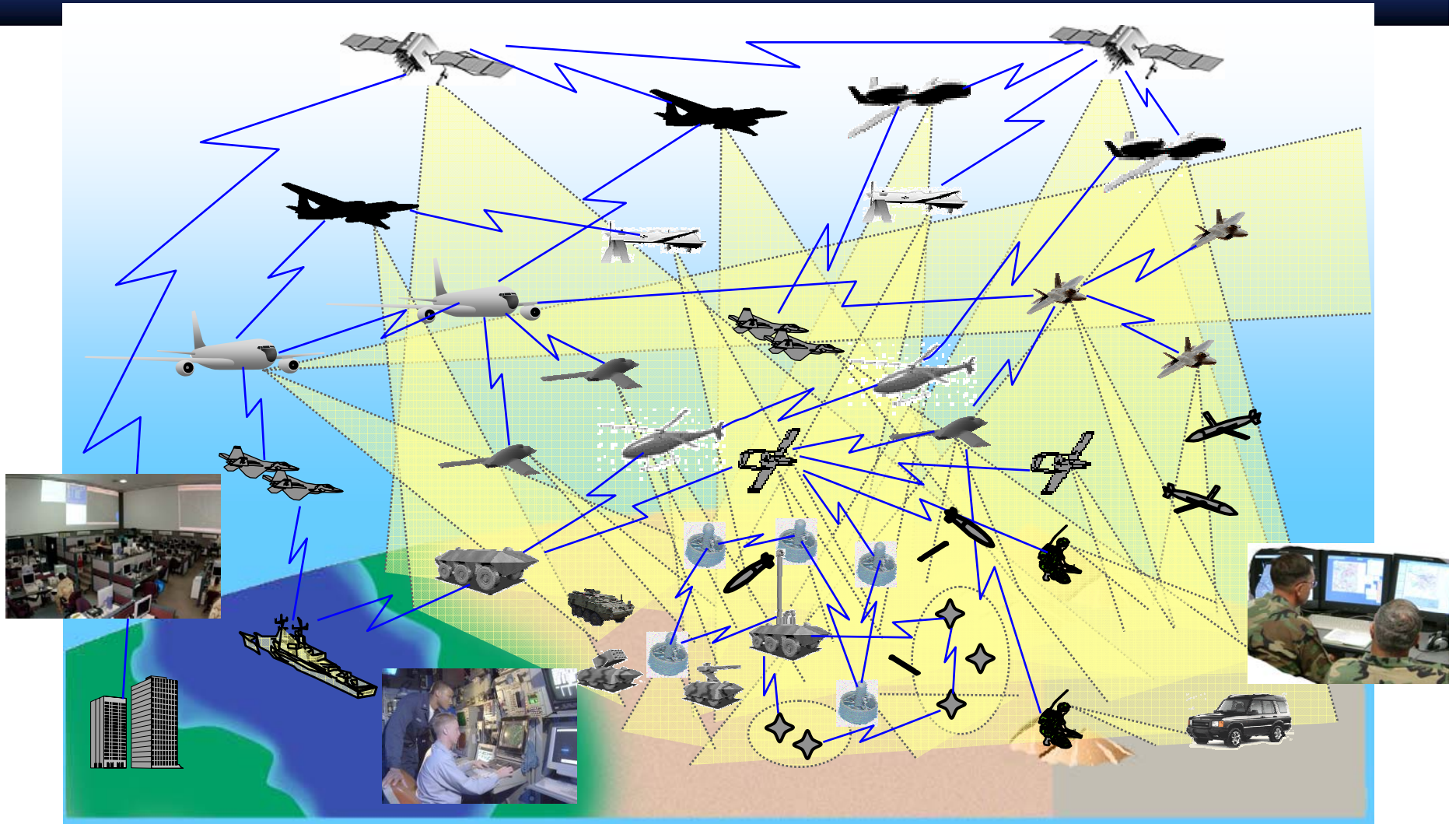

## Sensor Technology: Too much of a good thing?

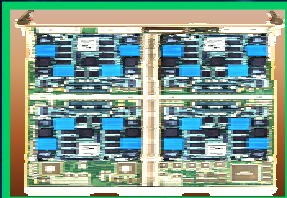

Compress: Compute hard, throw away 80% of the Megapixels for Downlink through tiny pipe

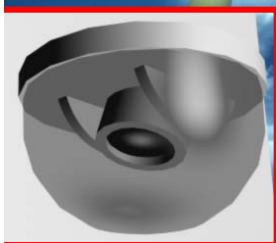

Reality:  
High Resolution Image :  
Big Optics, Megapixel Data

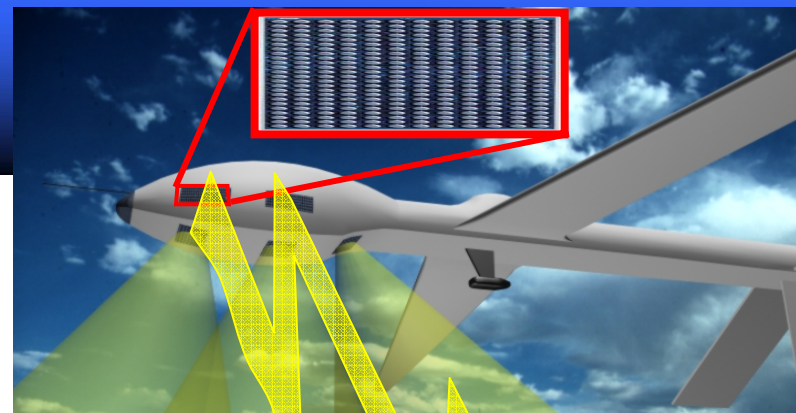

Vision:  
Compressed Camera *directly measures*  
Compressed representation for downlink

### ***Uncomfortable Observation:***

**Compressibility means most of the megapixels are useless**

**BUT**

**The gold is hidden in a broad spatial bandwidth, need smarts to find it!**

**Shannon: must measure the megapixels then sieve the hidden gold**

**Perhaps Shannon had good reason to look worried?**



# Sensor Trend: Measure/digitize everything possible Mega pixels = goodness!

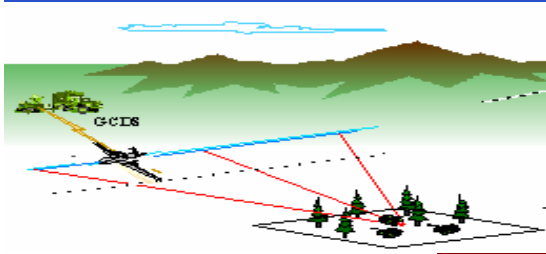

Physical Field  
(continuum)

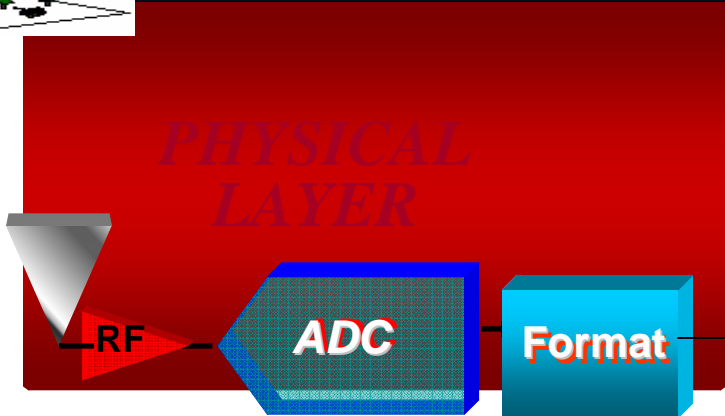
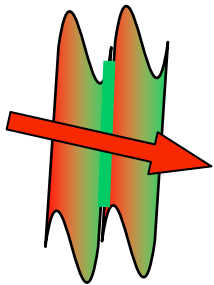

Digital Representation  
(Formatted)

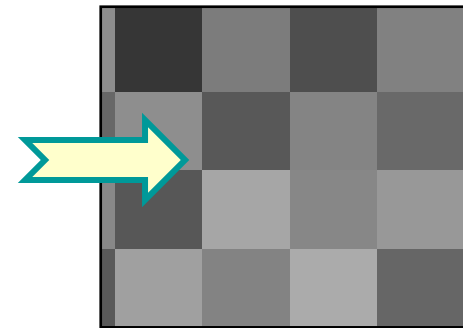

*Raw sensor data:*

*Huge Volume  
low information/sample  
Curse of Dimensionality*

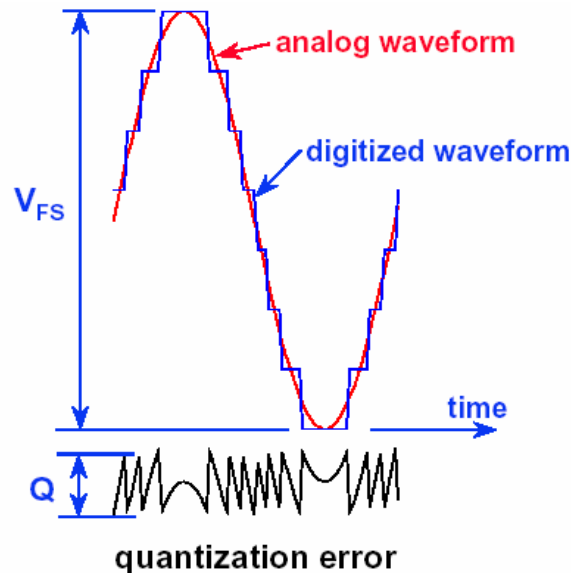

## Bellman and the Curse of Dimensionality



- Concept named by Richard Bellman

- Extraordinary growth in difficulty of doing business in higher dimensional spaces

- Optimization, Approximation

- Eg: “reasonable” function of  $d$  variables  $x_1, x_2, \dots, x_d$   $0 < x_i < 1$
- $O(1/\epsilon)^d$  samples to obtain  $O(\epsilon)$  accuracy

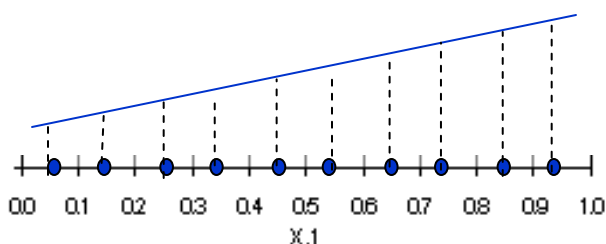

10 sample points are plenty in 1-d

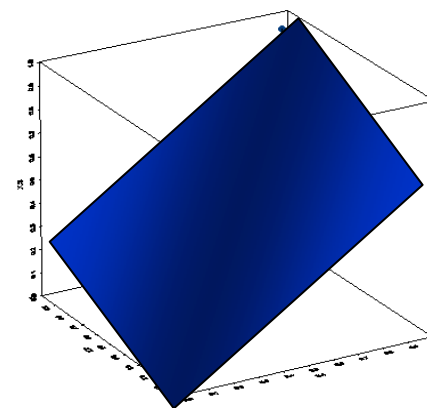

Would need 100 sample points in the 2-d domain

- Statistics Version: Requirement on priors/training to do meaningful inference

# High D, Ain't always the Place to Be

High dimensions are strange

The odd geometry of high d space

Wasteful packaging: The box for the high-d golf ball is essentially empty!

Volume is in the corners



volume of the hypercube is  $(2r)^d$ .

volume of the sphere is  $\frac{2r^d \pi^{d/2}}{d \Gamma(d/2)}$ .

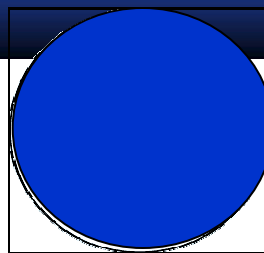

$$\frac{\pi^{d/2}}{d 2^{d-1} \Gamma(d/2)} \rightarrow 0$$

Most of uniform samples are in the corners

## Curses

Dimensionality	Required Sample Size
1	4
2	19
5	786
7	10,700
10	842,000

Required samples to estimate Gaussian density accurately at center

- Makes inference unreliable w/o more prior or training data
- Tends to make computation intractable
- If important structure is really low-d, most of the high-d features mainly drive noise into the application

increasing test set error

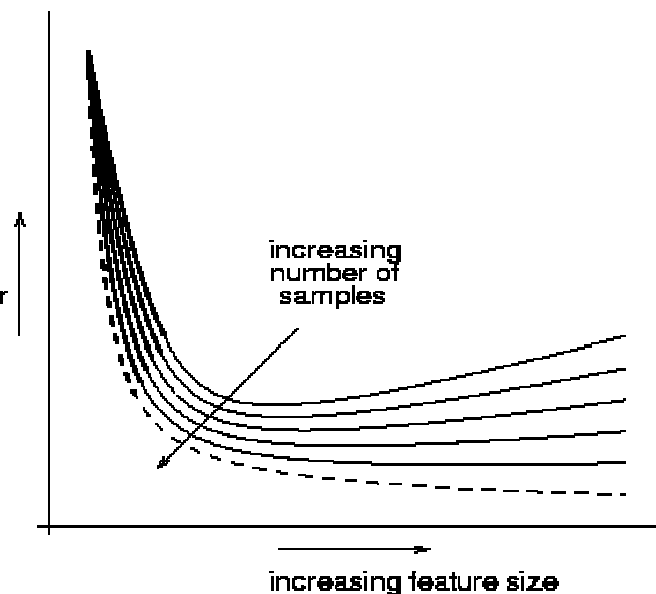

Bayes error

increasing feature size

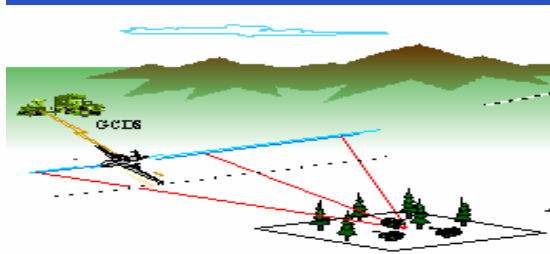

Physical Field  
(continuum)

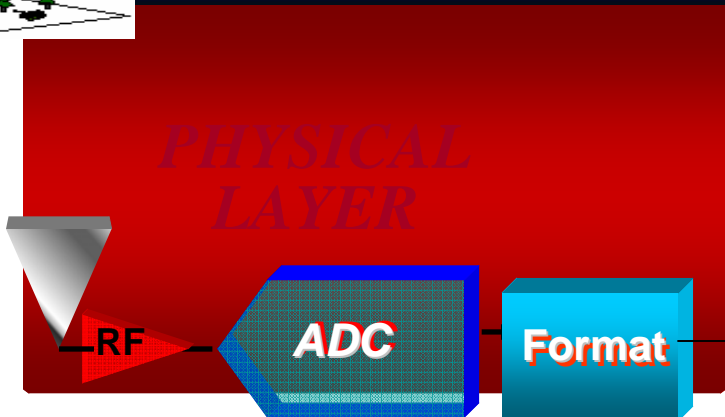
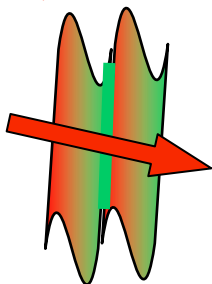

Digital Representation  
(Formatted)

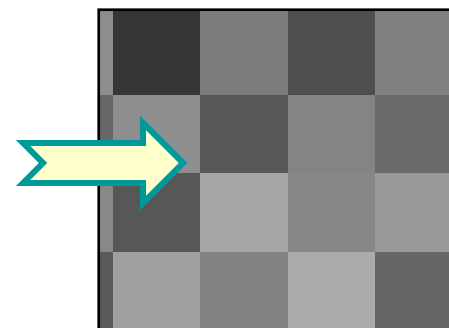

*Raw sensor data:*

*Huge Volume  
low information/sample  
Curse of Dimensionality*

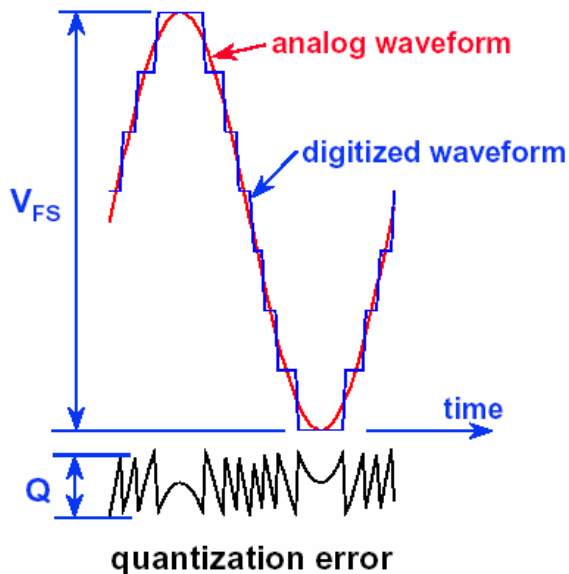



...is just the first link in a chain

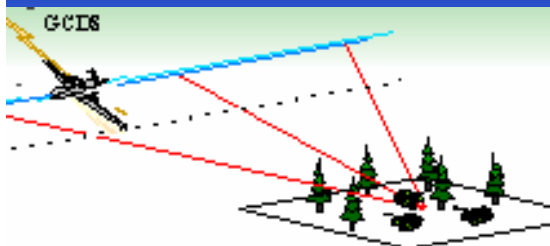

**Physical Field**  
(continuum)

**Digital Representation**  
(finite precision finite dimensional)

**Transformed**  
**Digital Representation**

**Symbolic Output**

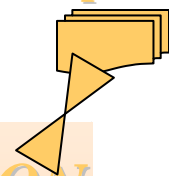
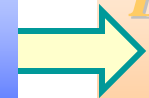
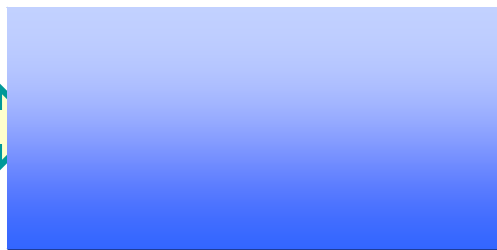
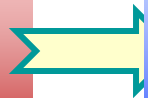
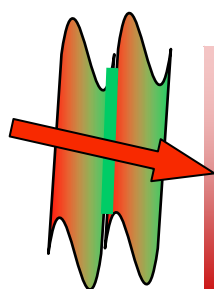

*Raw sensor data:*  
*low information/dimension*

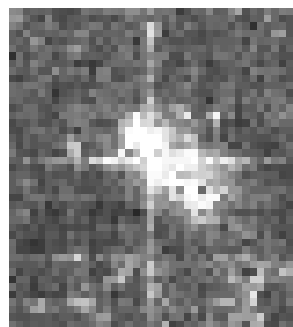

*Enhanced feature data:*  
*more information/dimension*

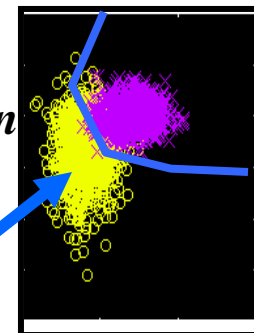
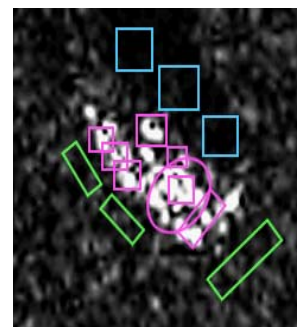

**Sensor: Work hard in the physical layer to measure everything at the highest fidelity**  
**Processor: Work hard to throw away most of that data to get at the "good stuff"**

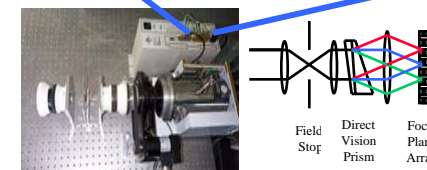
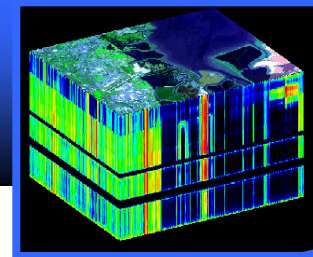
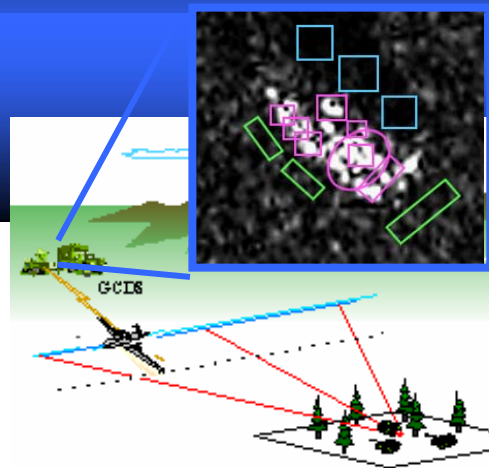
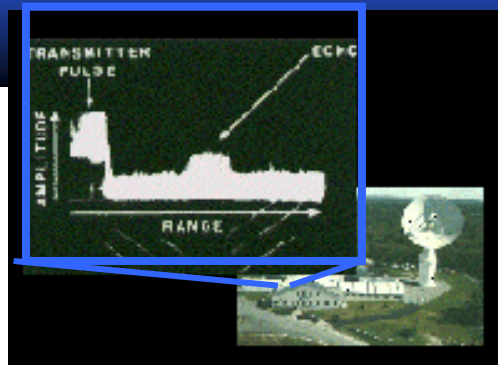

Cooley Tukey FFT

Subspace Methods

Wavelets

Approximation Optimization

Best Basis

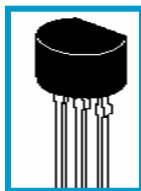
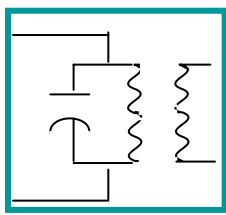
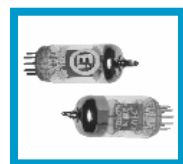

- *Increased complexity, dimensionality of sensing and exploitation tasks*
- *Decoupling of Digital and Analog subsystems, independently designed and optimized*
- *Steady Moore's Law growth of digital throughput (integration growth path)*
- *Equal impact of fast algorithms (representations), but sporadic, unpredictable*

Physical Field  
(continuum)

Digital Representation  
(finite precision finite dimensional)

Transformed  
Digital Representation

Symbolic Output

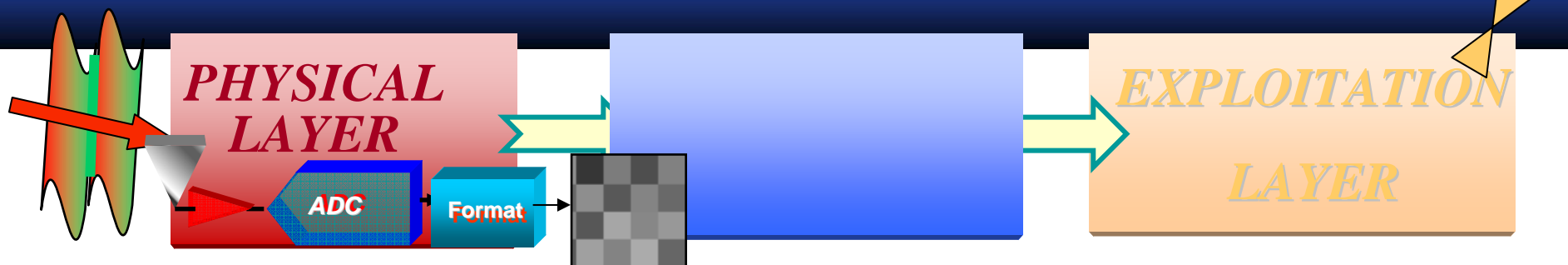

## Keep trying to measure/digitize everything at highest possible resolution?

- A No-brainer
- No-brainer! Maybe not always true!
  - Slow, expensive growth rate of resolution in A/D's
  - Curse of dimensionality: shouldn't do it even if you could!
- What might be better?
  - Dedicate Front end resources to measuring more of the “good stuff”
  - Sensing “features” at front end could reduce load on A/D and subsequent digital processing and exploitation.
  - If done properly, overall system performance can be improved even with the lower requirements on subsequent digital processing
- **Problem: the “smarts” for finding the “good stuff” are behind the ADC!**

Today's Sensor Systems are typically feed-forward networks for transforming information in specialized stages.

Dimension reduction is mainly applied at the back of the bus

Physical Field  
(continuum)

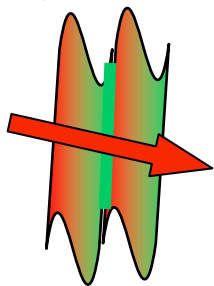

Digital Representation  
(finite precision  
finite dimensional)



Transformed  
Digital Representation



Symbolic Output

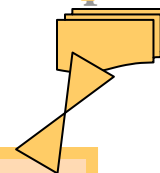

*Raw sensor data:  
low information/dimension*

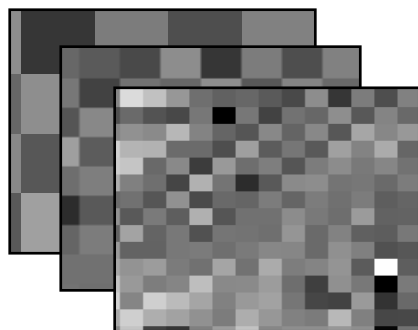

*DSP produces data reps with  
higher information/dimension*



*Fast approximate  
solution of a high  
dimensional non  
linear optimization  
problem*

## Meeting the Challenges: *Integrated Optimization of the System*

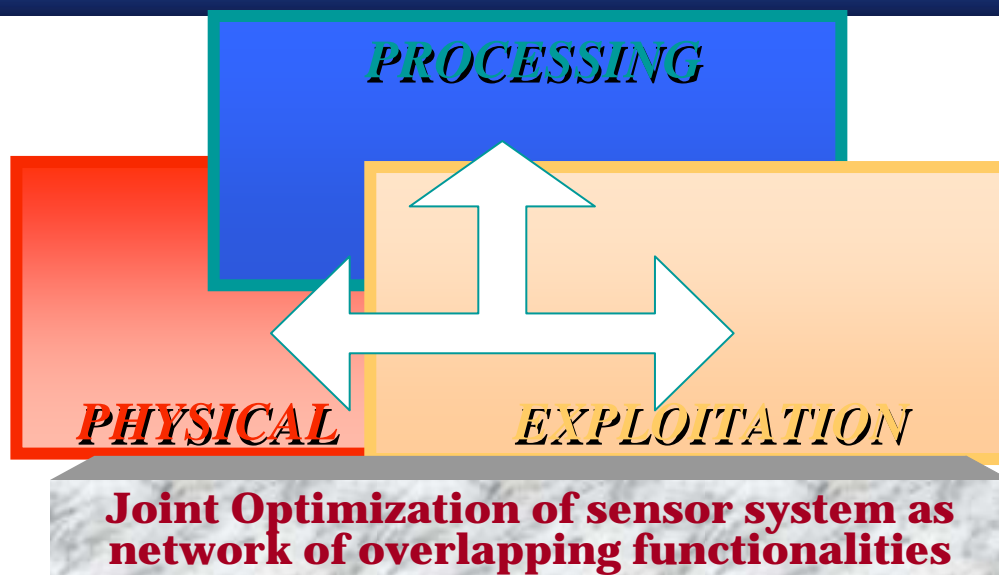

*Components will have overlapping and dynamically reconfigurable roles and full network connectivity. (**LOAD BALANCING**)*

*Make “customized” measurements at physical layer under real-time feedback control from the exploitation and processing system. **“20 Questions”***

*Manage/Prioritize **data** stream to affordable levels without discarding needed **information***