

# The Impact of Accelerating Information Technology on War and Peace

26<sup>th</sup> Army Science Conference  
December 1, 2008

Ray Kurzweil



KurzweilAI.net

# Report Documentation Page

*Form Approved  
OMB No. 0704-0188*

Public reporting burden for the collection of information is estimated to average 1 hour per response, including the time for reviewing instructions, searching existing data sources, gathering and maintaining the data needed, and completing and reviewing the collection of information. Send comments regarding this burden estimate or any other aspect of this collection of information, including suggestions for reducing this burden, to Washington Headquarters Services, Directorate for Information Operations and Reports, 1215 Jefferson Davis Highway, Suite 1204, Arlington VA 22202-4302. Respondents should be aware that notwithstanding any other provision of law, no person shall be subject to a penalty for failing to comply with a collection of information if it does not display a currently valid OMB control number.

1. REPORT DATE <b>DEC 2008</b>	2. REPORT TYPE <b>N/A</b>	3. DATES COVERED <b>-</b>	
4. TITLE AND SUBTITLE <b>The Impact of Accelerating Information Technology on War and Peace</b>		5a. CONTRACT NUMBER	
		5b. GRANT NUMBER	
		5c. PROGRAM ELEMENT NUMBER	
6. AUTHOR(S)		5d. PROJECT NUMBER	
		5e. TASK NUMBER	
		5f. WORK UNIT NUMBER	
7. PERFORMING ORGANIZATION NAME(S) AND ADDRESS(ES) <b>Kurzweil Technologies, Inc.</b>		8. PERFORMING ORGANIZATION REPORT NUMBER	
9. SPONSORING/MONITORING AGENCY NAME(S) AND ADDRESS(ES)		10. SPONSOR/MONITOR'S ACRONYM(S)	
		11. SPONSOR/MONITOR'S REPORT NUMBER(S)	
12. DISTRIBUTION/AVAILABILITY STATEMENT <b>Approved for public release, distribution unlimited</b>			
13. SUPPLEMENTARY NOTES <b>See also ADM002187. Proceedings of the Army Science Conference (26th) Held in Orlando, Florida on 1-4 December 2008, The original document contains color images.</b>			
14. ABSTRACT			
15. SUBJECT TERMS			
16. SECURITY CLASSIFICATION OF:			17. LIMITATION OF ABSTRACT
a. REPORT <b>unclassified</b>	b. ABSTRACT <b>unclassified</b>	c. THIS PAGE <b>unclassified</b>	<b>UU</b>
			18. NUMBER OF PAGES <b>142</b>
			19a. NAME OF RESPONSIBLE PERSON



Kurzweil Reading Machine (Circa 1979)

# The Law of Accelerating Returns

- The price-performance, capacity & bandwidth of information technologies progresses exponentially through multiple paradigm shifts
  - Specific to information technology
    - not to arbitrary exponential trends (like population)
    - Still need to test viability of the next paradigm
  - A scientific theory
    - 25 years of research
    - Part of a broader theory of evolution
    - Inventing: science and engineering
  - Moore's law just one example of many
  - Yes there are limits
    - But they're not very limiting
      - Based on the physics of computation and communication
      - and on working paradigms (such as nanotubes)

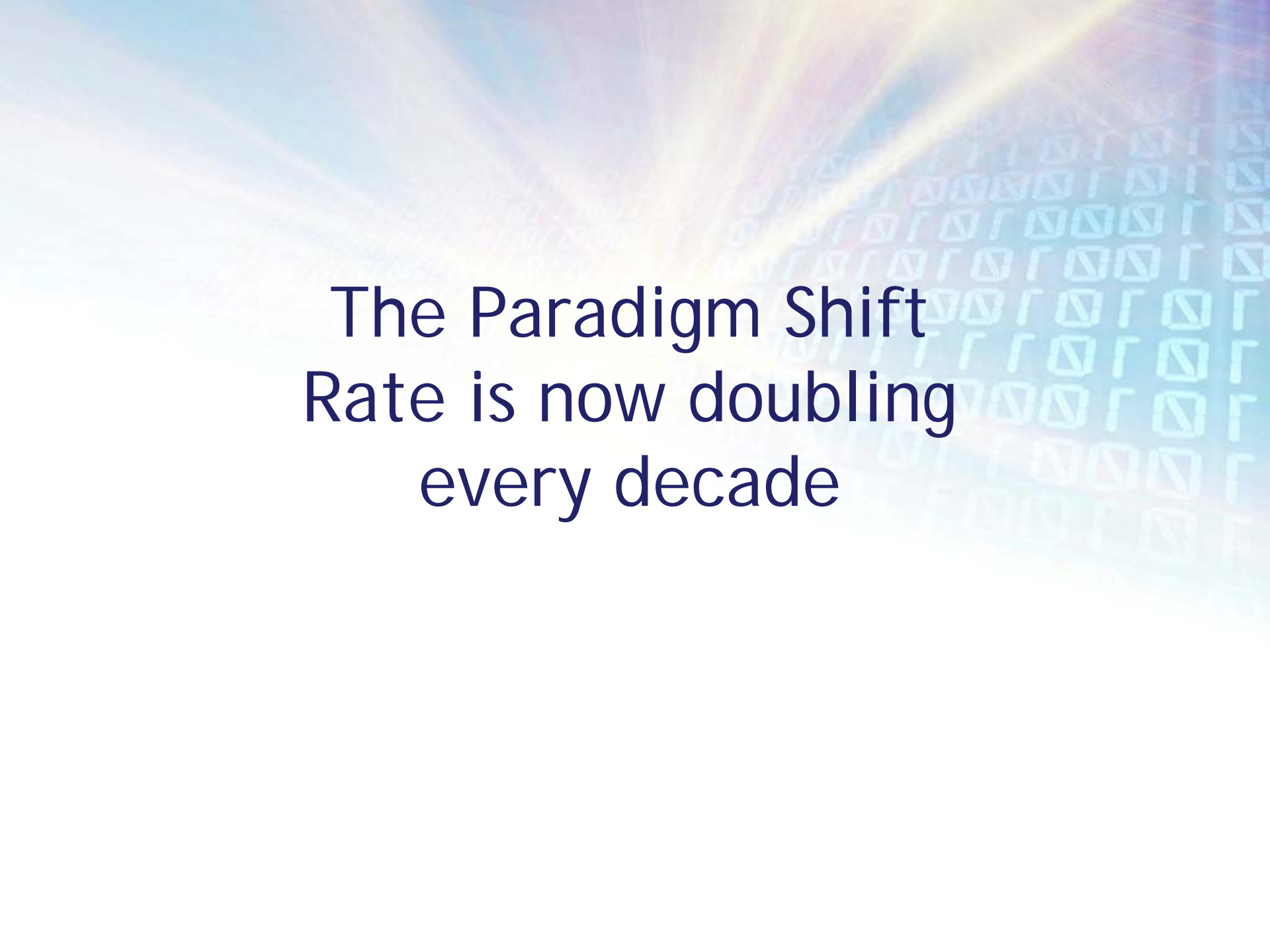

The Paradigm Shift  
Rate is now doubling  
every decade

# Growth of U.S. Phone Industry



Logarithmic Plot

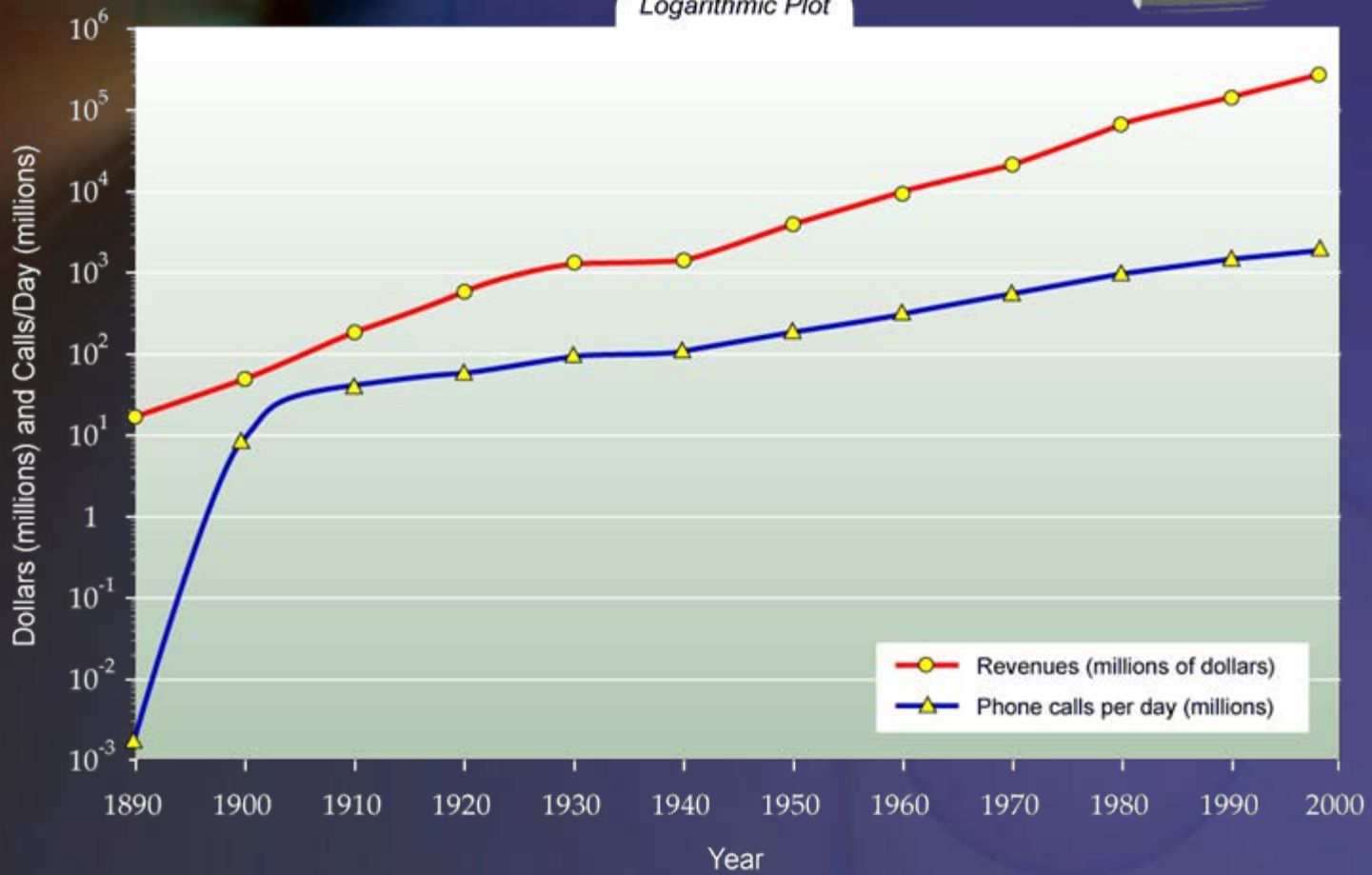

Estimated U.S.  
**Cell Phone Subscribers**

Logarithmic Plot

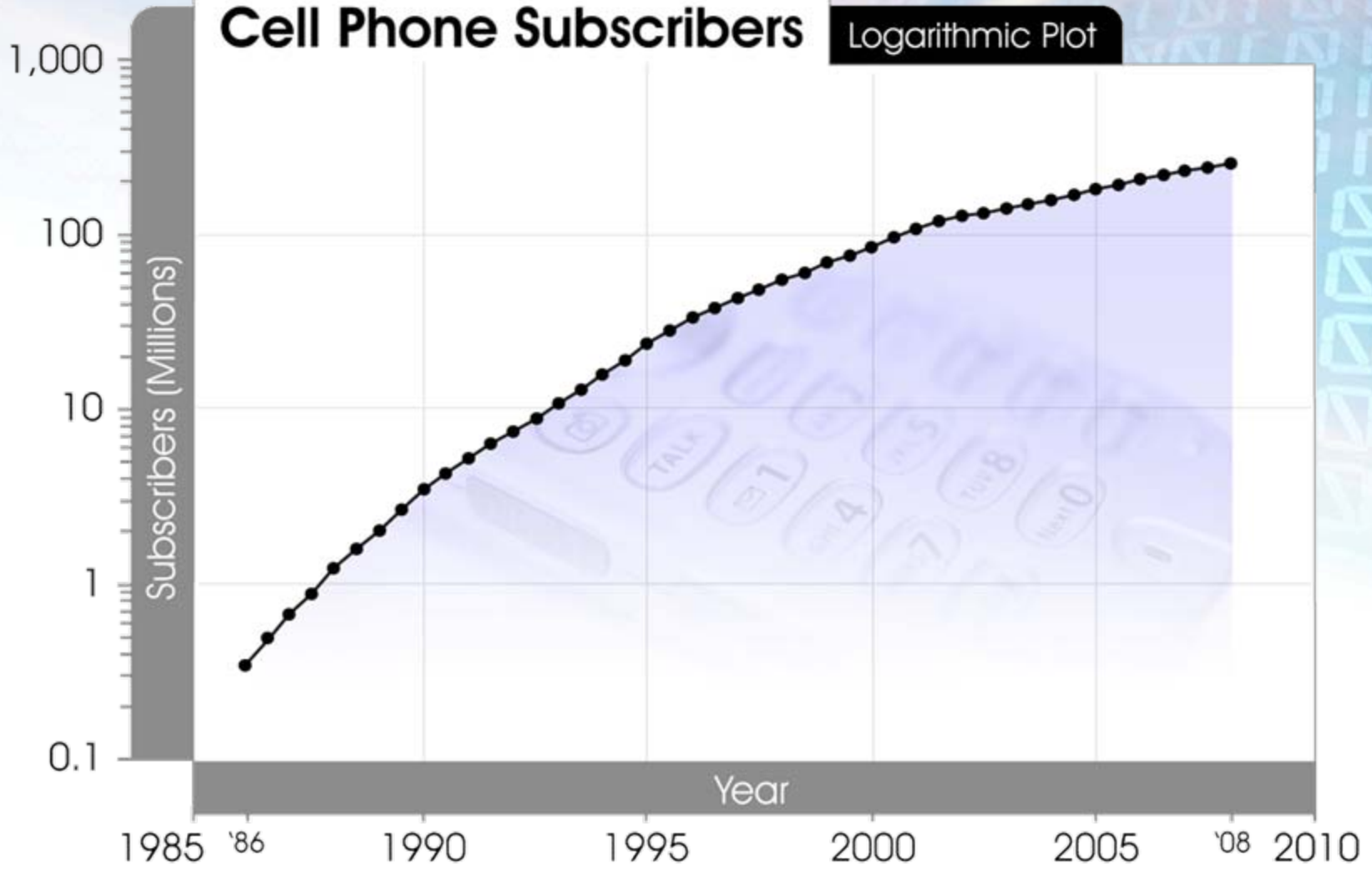

# Mass Use of Inventions

Years Until Use by 1/4 U.S. Population



Logarithmic Plot

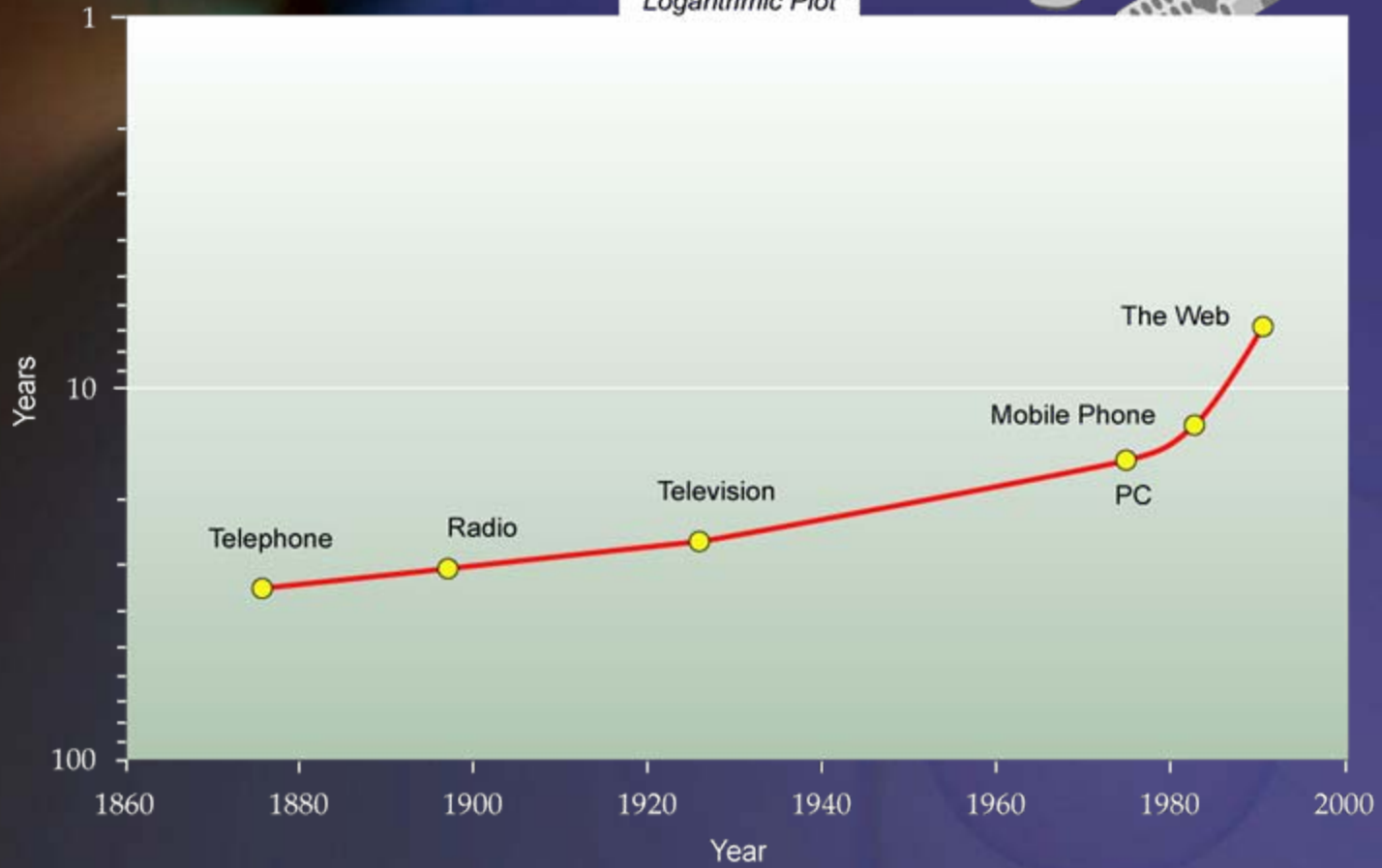

# Countdown to Singularity

Logarithmic Plot

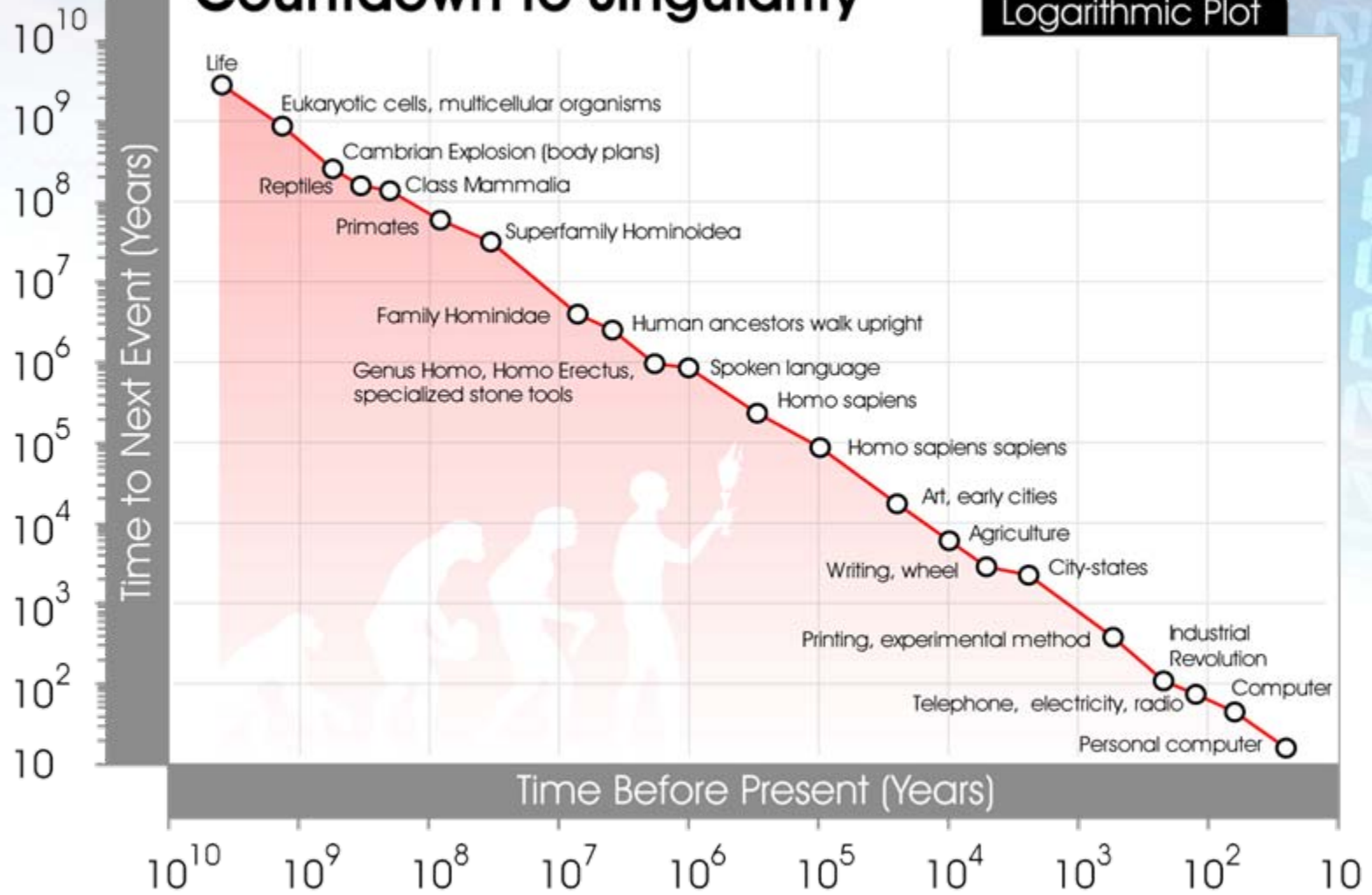

# Countdown to Singularity

Linear Plot

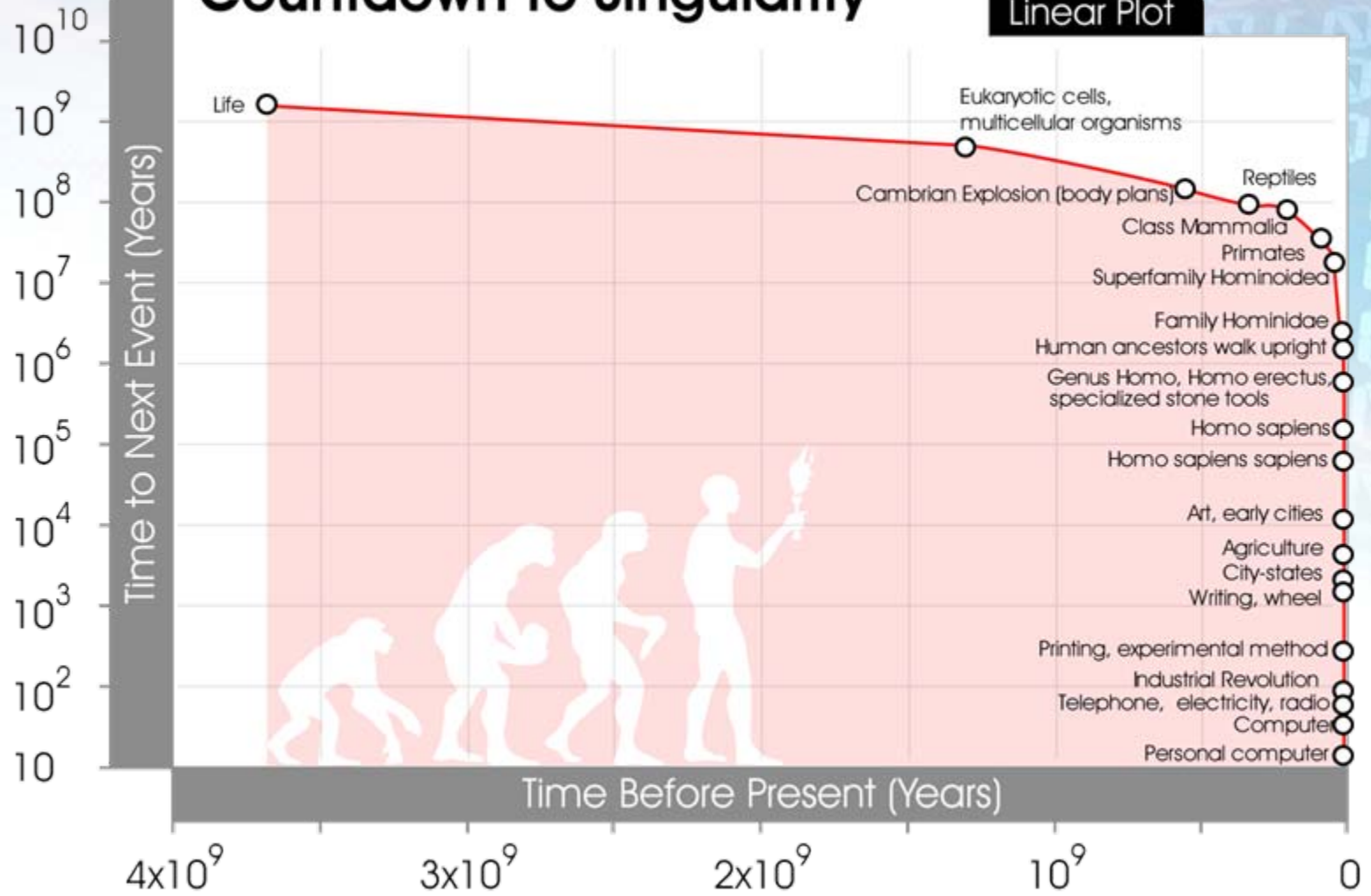

15 Lists of Key events  
**Paradigm Shifts**

Logarithmic Plot

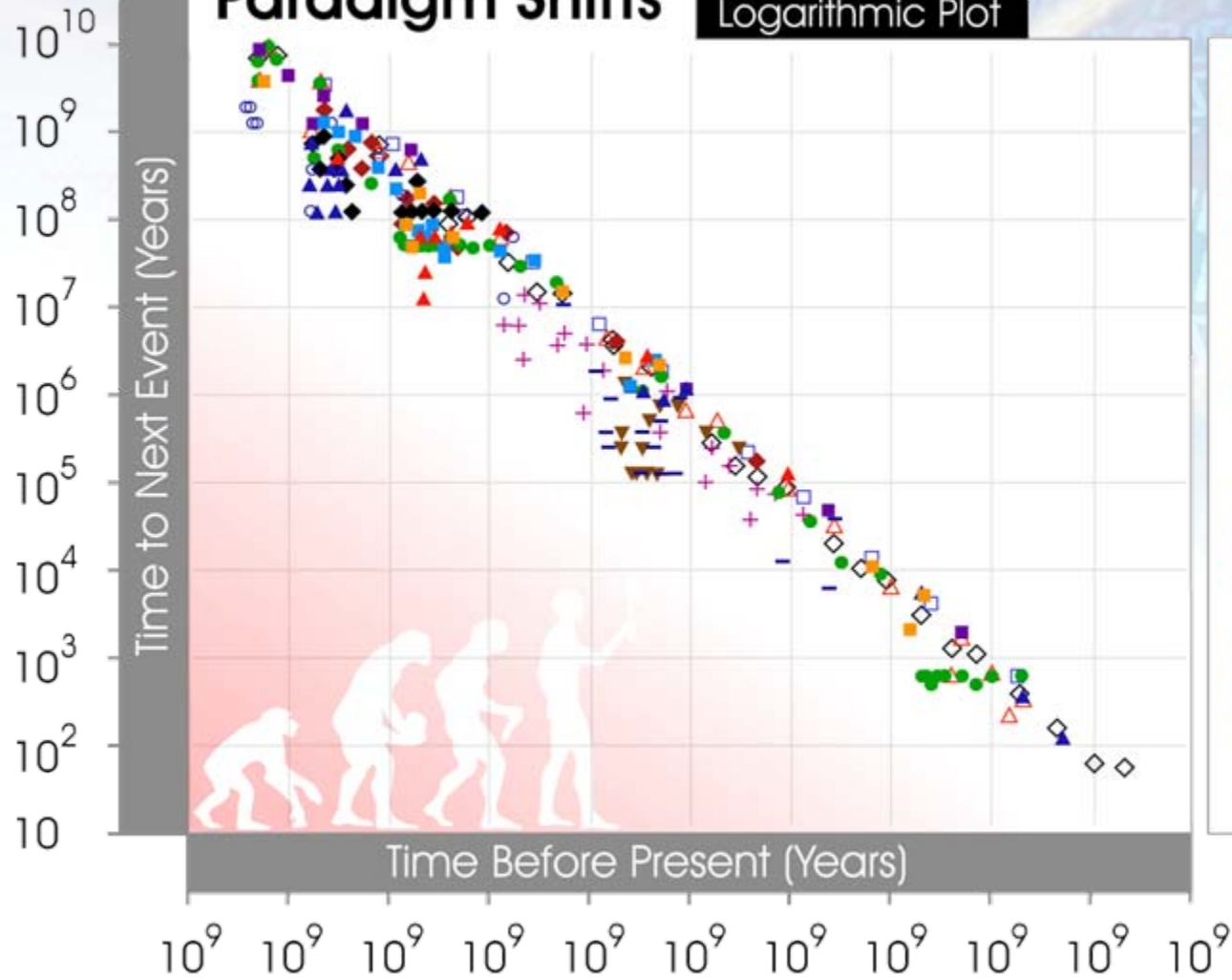

- Carl Sagan
- American Museum of Natural History
- ▲ Encyclopedia Britannica
- ERAPS at University of Arizona
- ▲ Paul Boyer
- Barrow and Silk
- Jean Heidmann
- ◆ IGPP Symposium
- Phillip Tobias
- ◆ Davis Nelson
- + Goran Burenhult (ed.)
- ▼ Johanson and Edgar
- △ Modis 2002
- Richard Coren
- ◇ Modis 2003

# Canonical Milestones

Logarithmic Plot

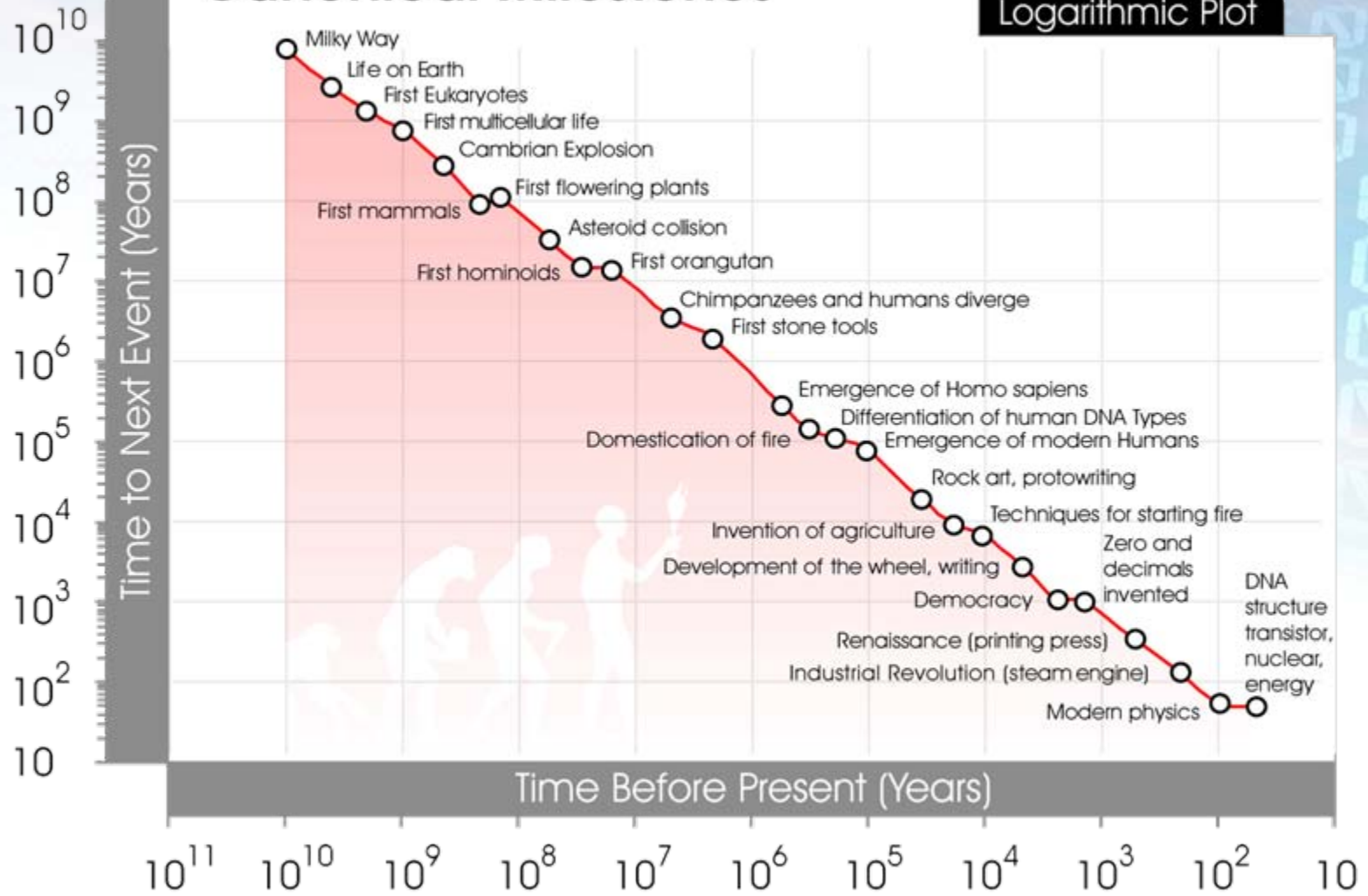

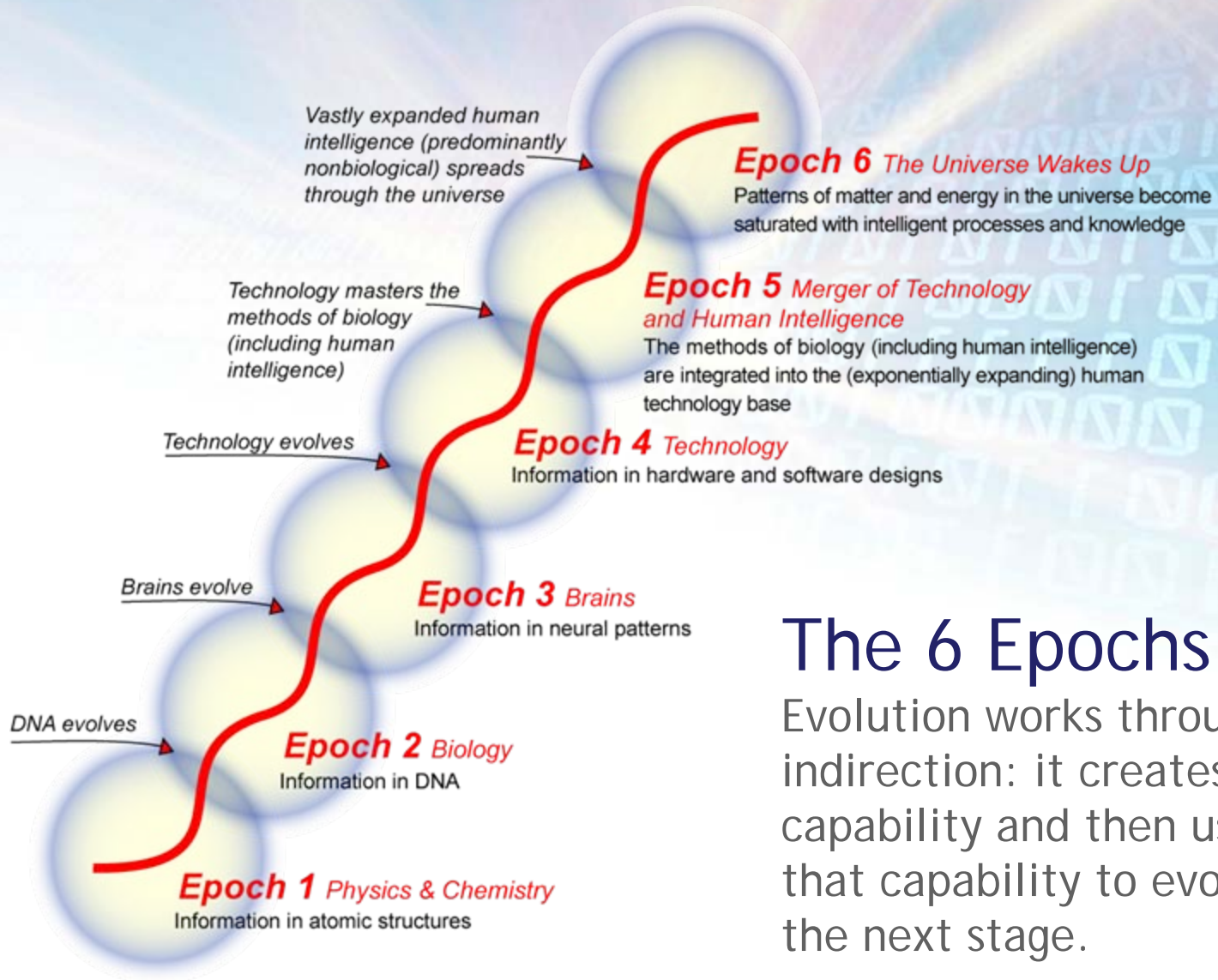

**The 6 Epochs:**  
Evolution works through indirection: it creates a capability and then uses that capability to evolve the next stage.

Growth:

# Linear vs. Exponential

Linear Plot

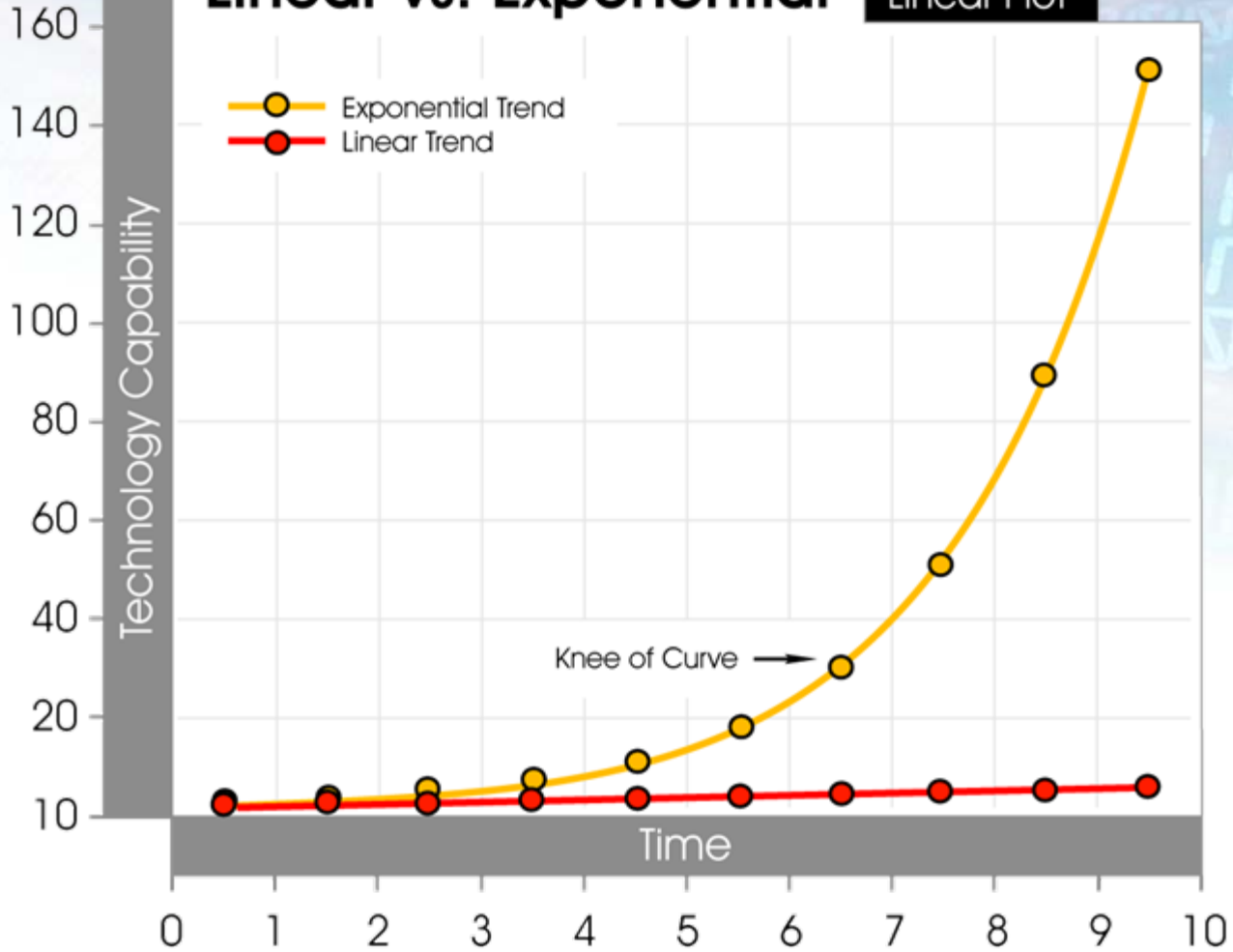

An ongoing exponential sequence made up of a cascade of S-curves (linear plot)

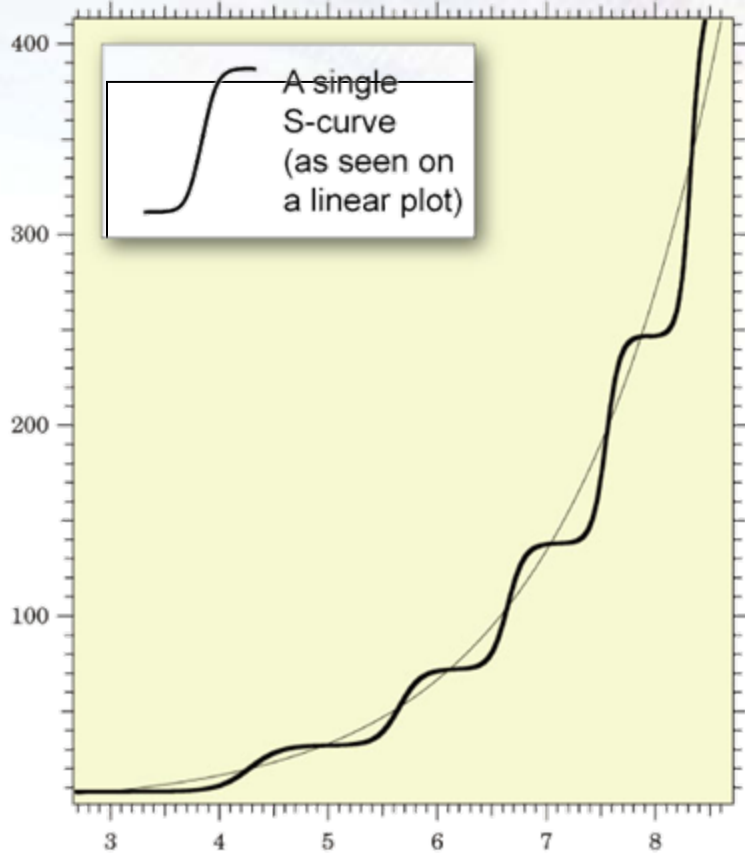

The same exponential sequence of S-curves on a logarithmic plot

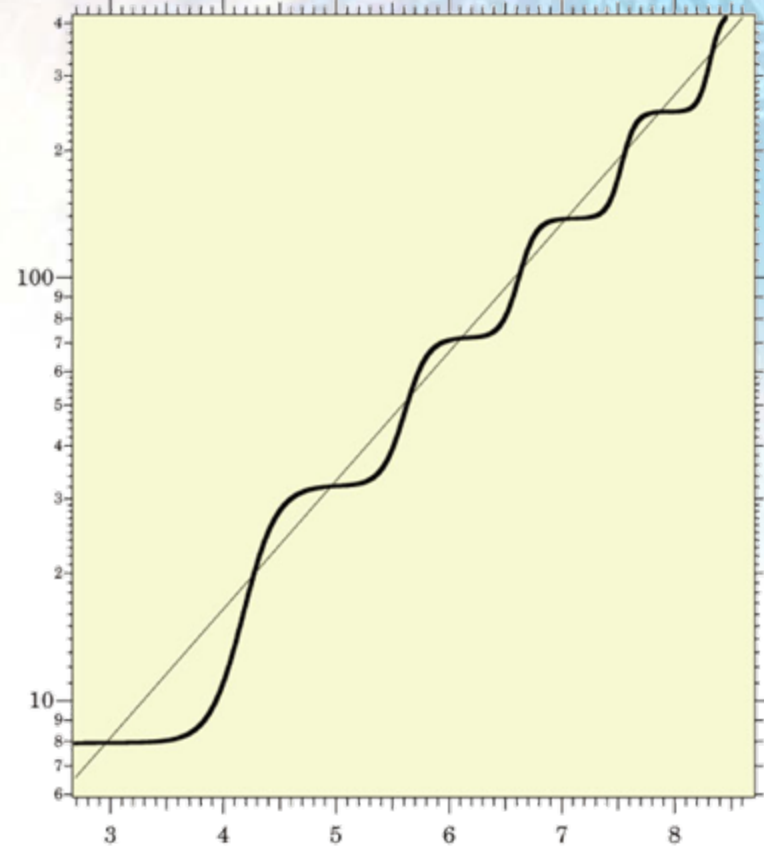



Information Technologies (of all kinds) double their power (price performance, capacity, bandwidth) every year

# *A Personal Experience*

Measure	MIT's IBM 7094	Notebook Circa 2003
Year	1967	2003
Processor Speed (MIPS)	0.25	1,000
Main Memory (K Bytes)	144	256,000
Approximate Cost (2003 \$)	\$11,000,000	\$2,000

24 Doublings of Price-Performance in 36 years, doubling time: 18 months not including vastly greater RAM memory, disk storage, instruction set, etc.



Moore's Law is one  
example of many...

# Exponential Growth of Computing for 110 Years

Moore's Law was the Fifth, not the First, Paradigm to Bring Exponential Growth in Computing

Logarithmic Plot

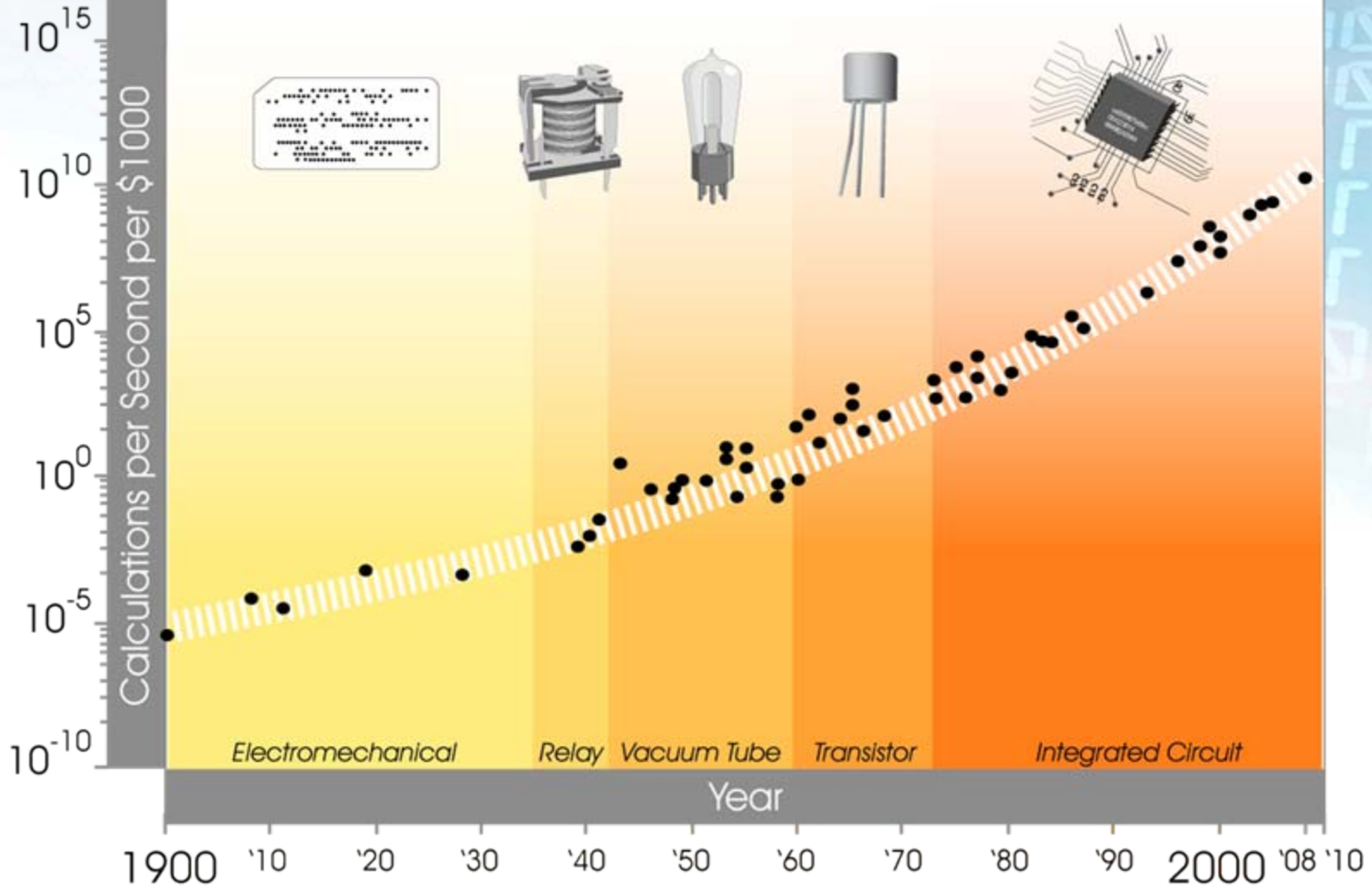

# Evolution of Computer Power/Cost

## Brain Power Equivalent per \$1000 of Computer

MIPS per \$1000 (1998 Dollars)

Million

1000

1

1  
1000

1  
Million

1  
Billion

1900

1920

1940

1960

1980

2000

2020

Year

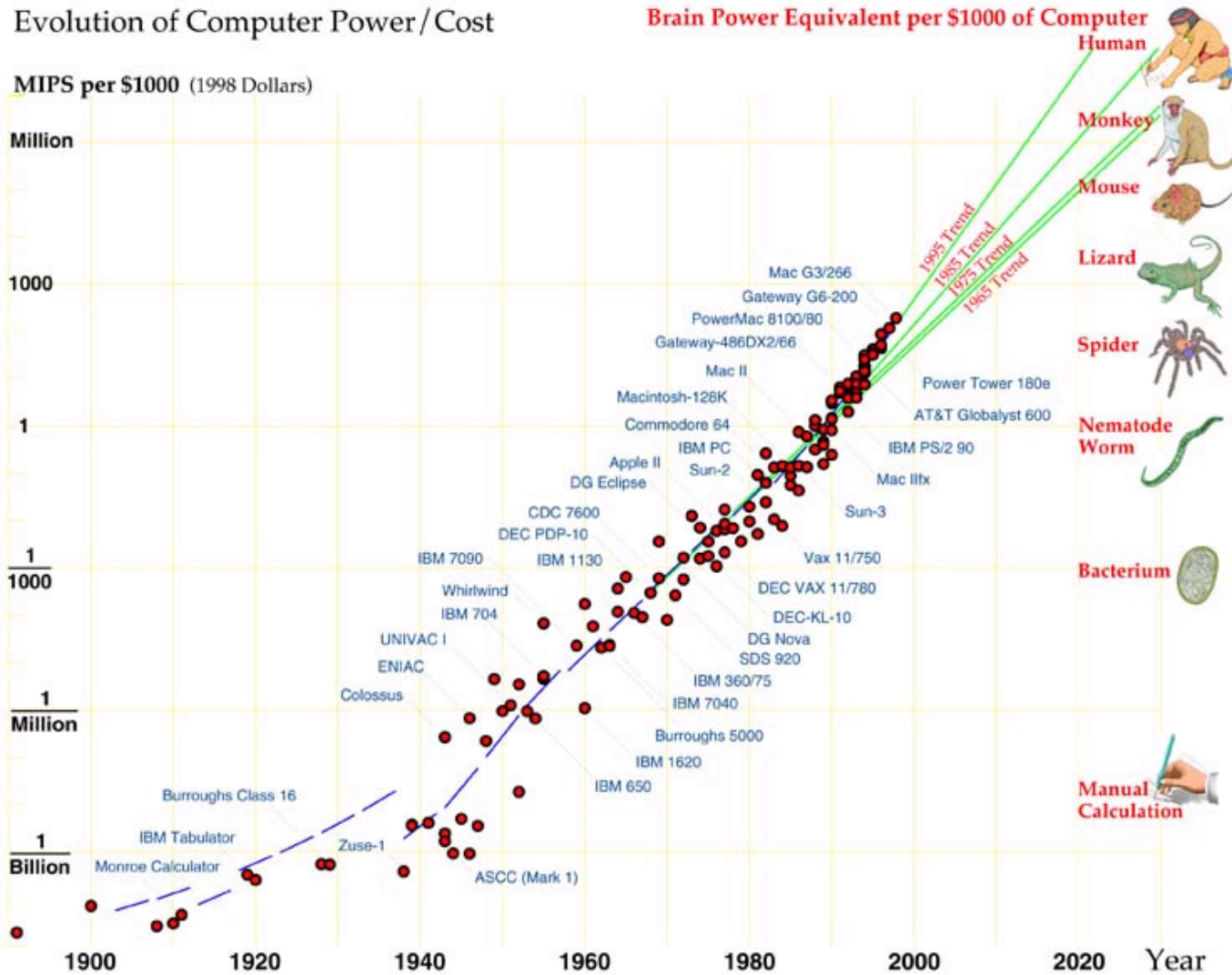

# Growth in Supercomputer Power

Logarithmic Plot

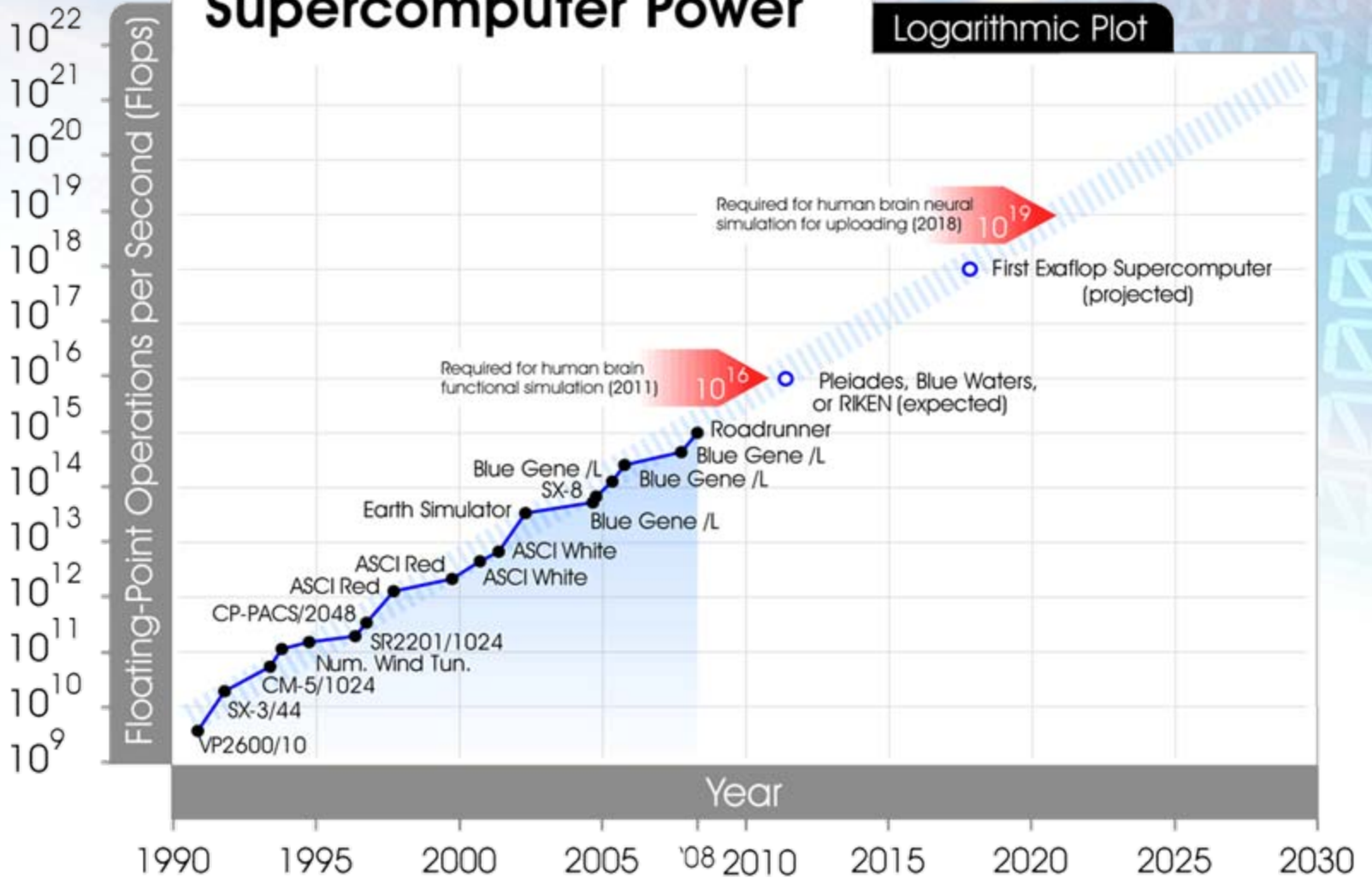

(Intel Processors)

# Transistors per Chip

Logarithmic Plot

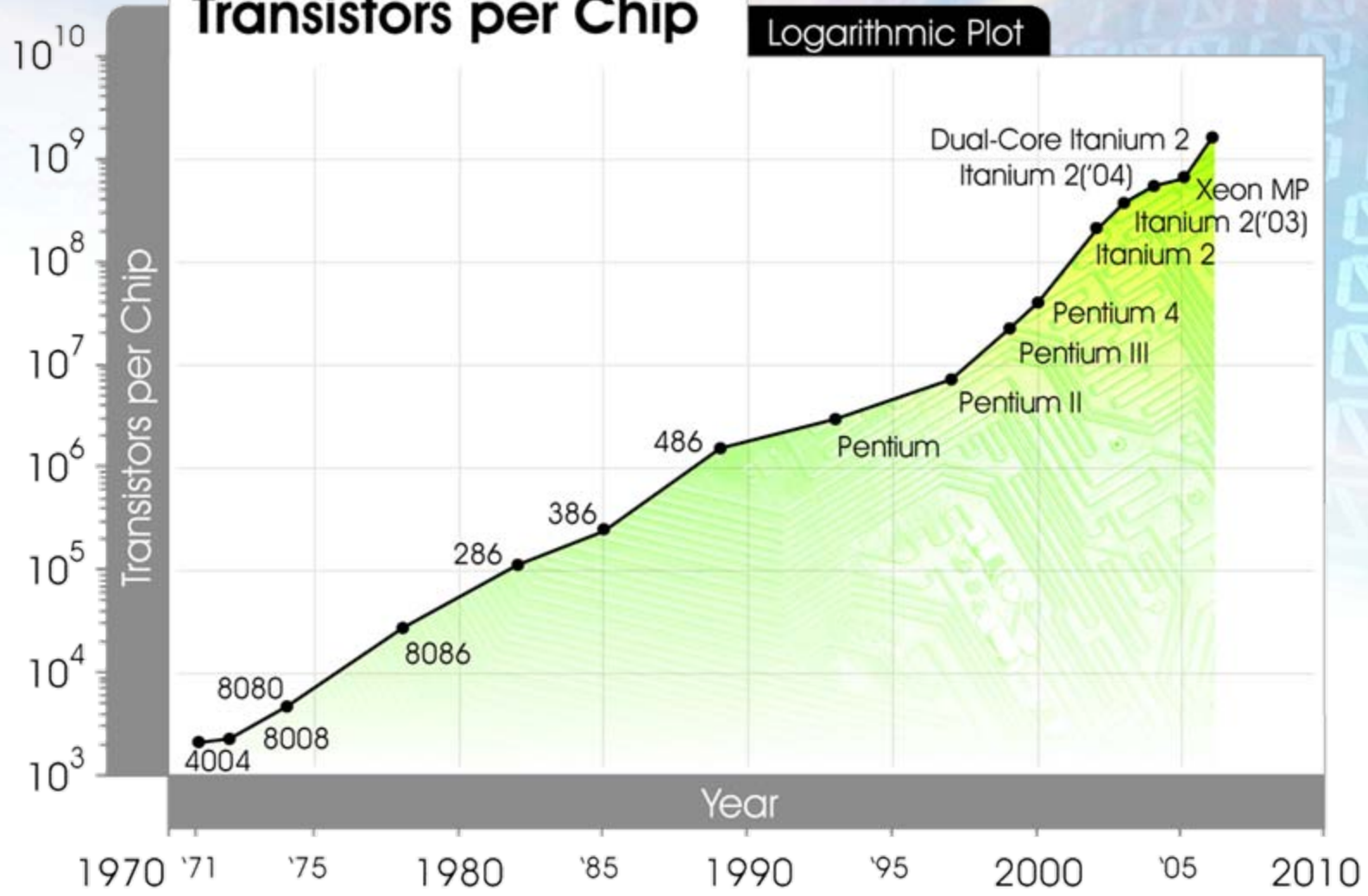

# Processor Performance (MIPS)

Logarithmic Plot

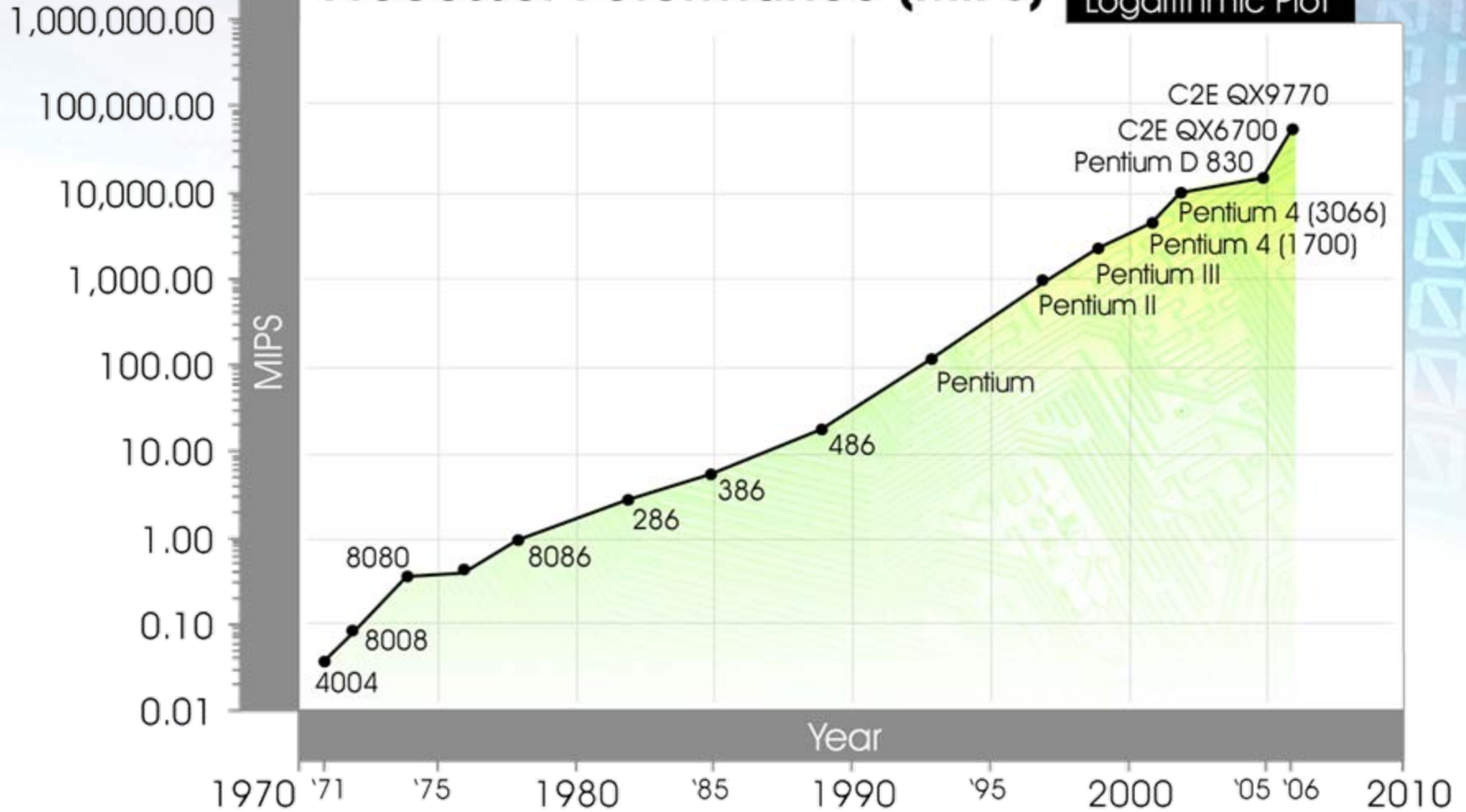

Bits per Dollar for Packaged Chips ("at production")

## Dynamic RAM Memory

Logarithmic Plot

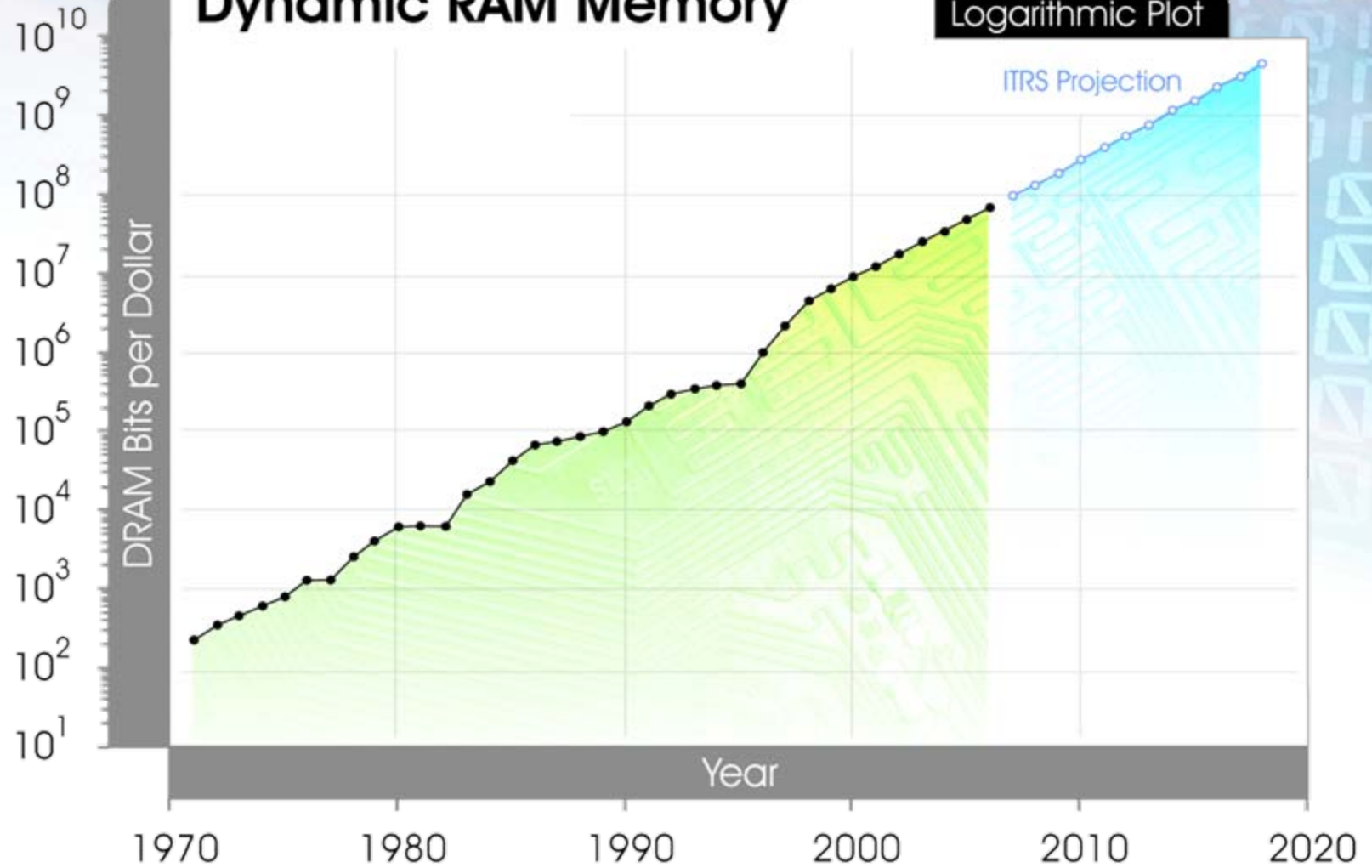

Bits per Dollar (1950-2008)

# Random Access Memory

Logarithmic Plot

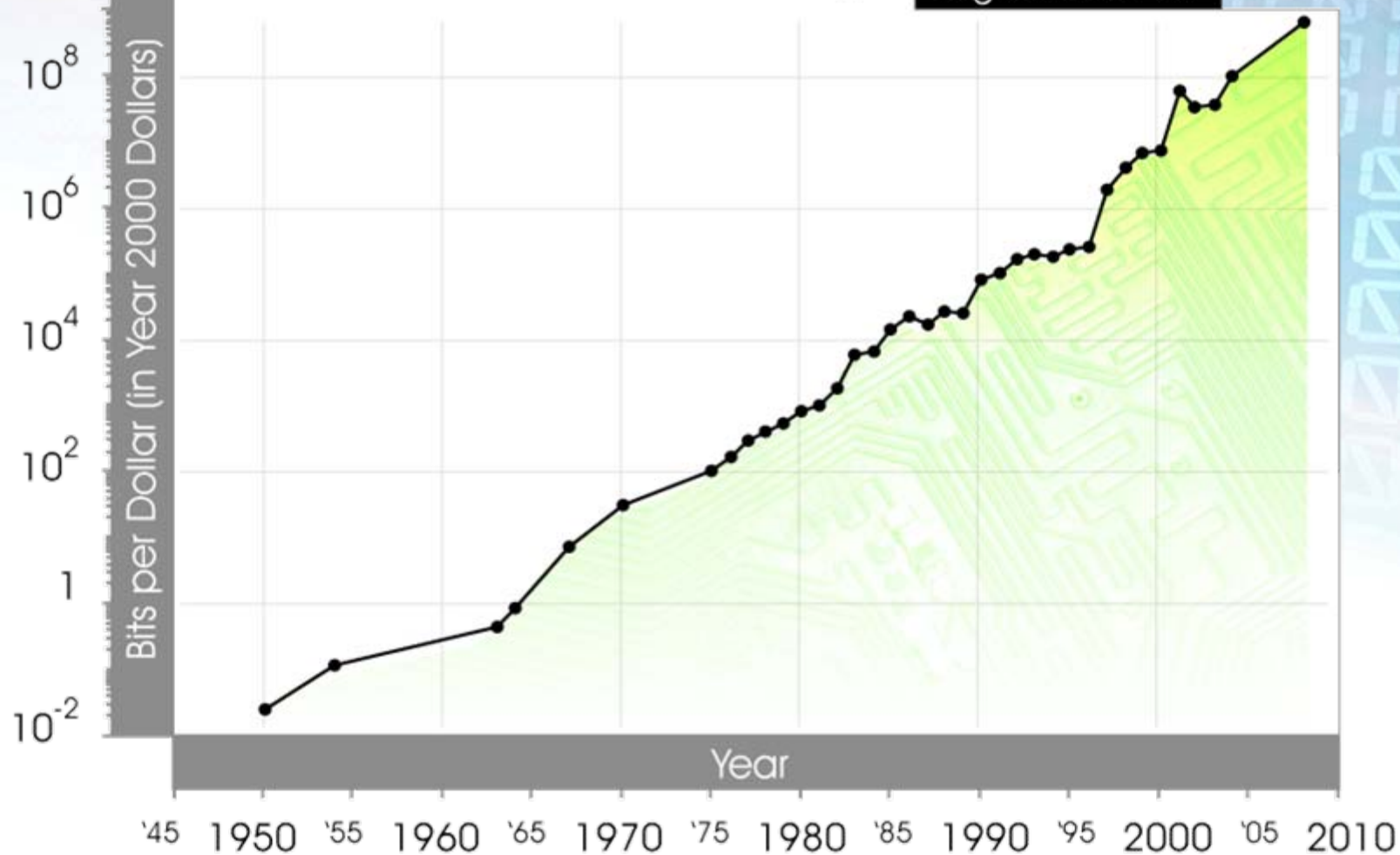

# Average Transistor Price

Logarithmic Plot

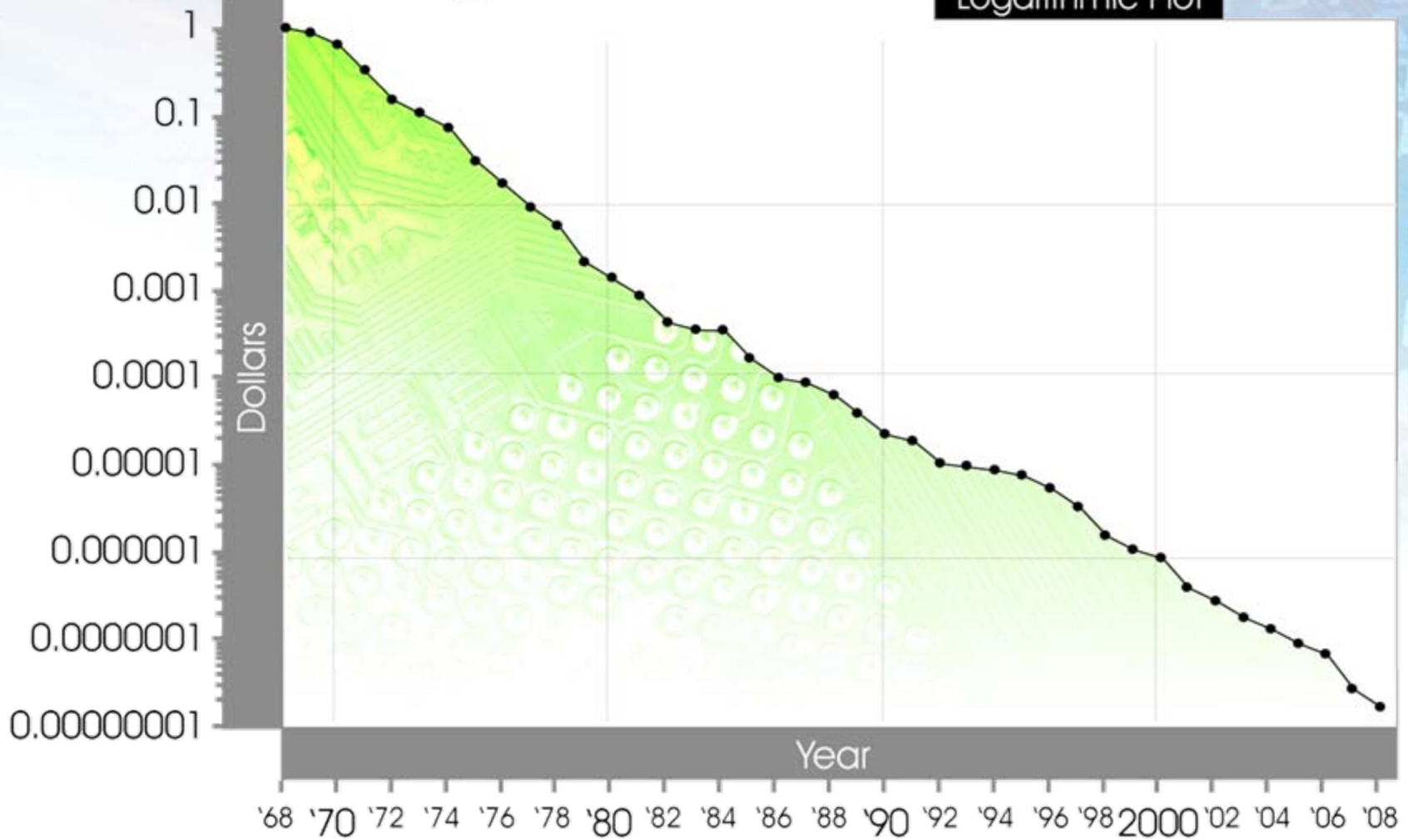

# Microprocessor Clock Speed

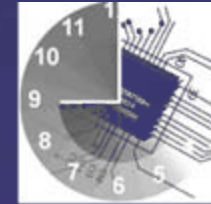

Logarithmic Plot

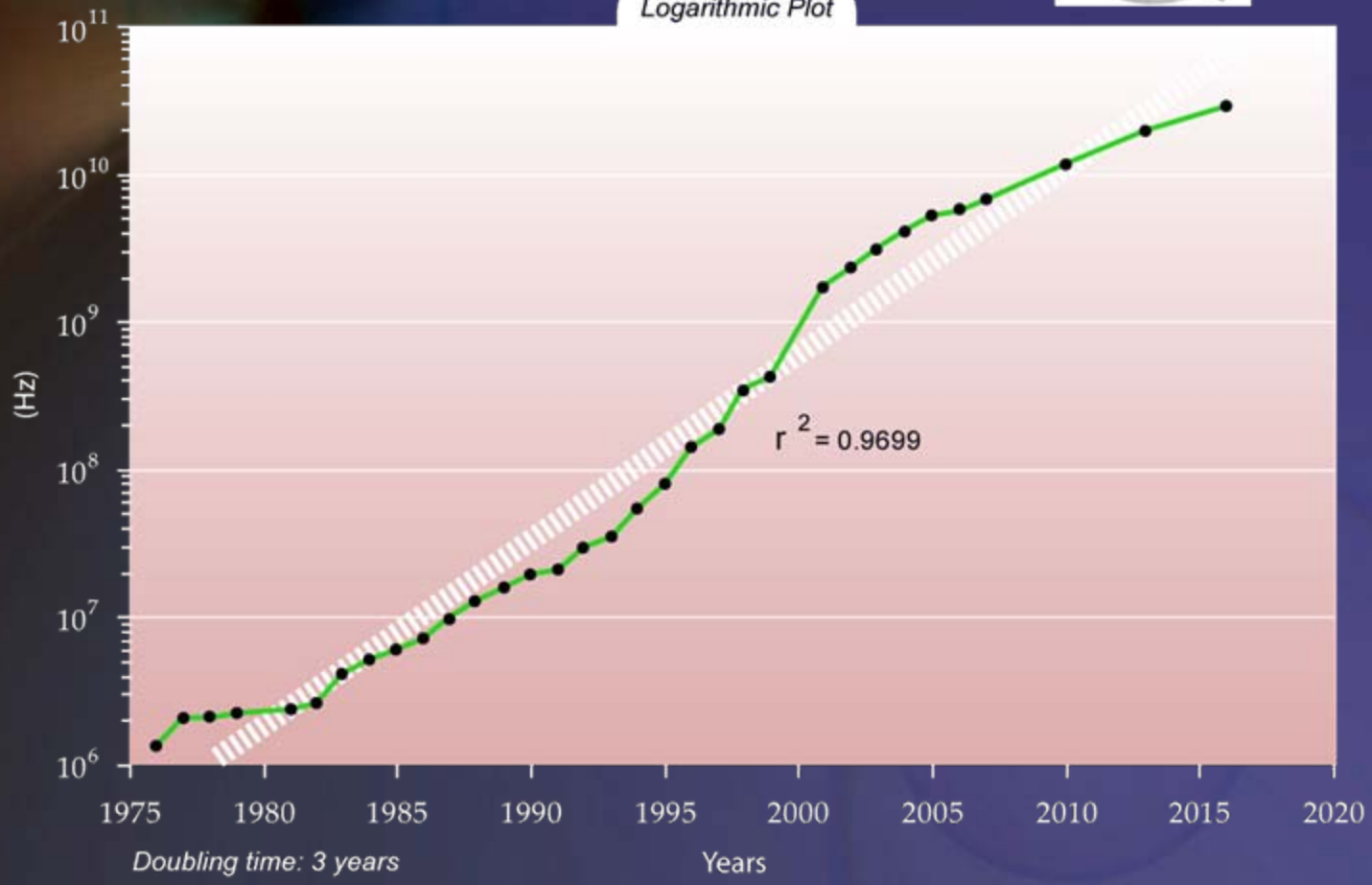

# Microprocessor Cost Per Transistor/Cycle

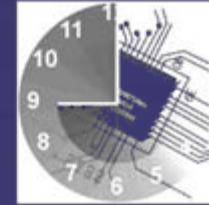

Logarithmic Plot

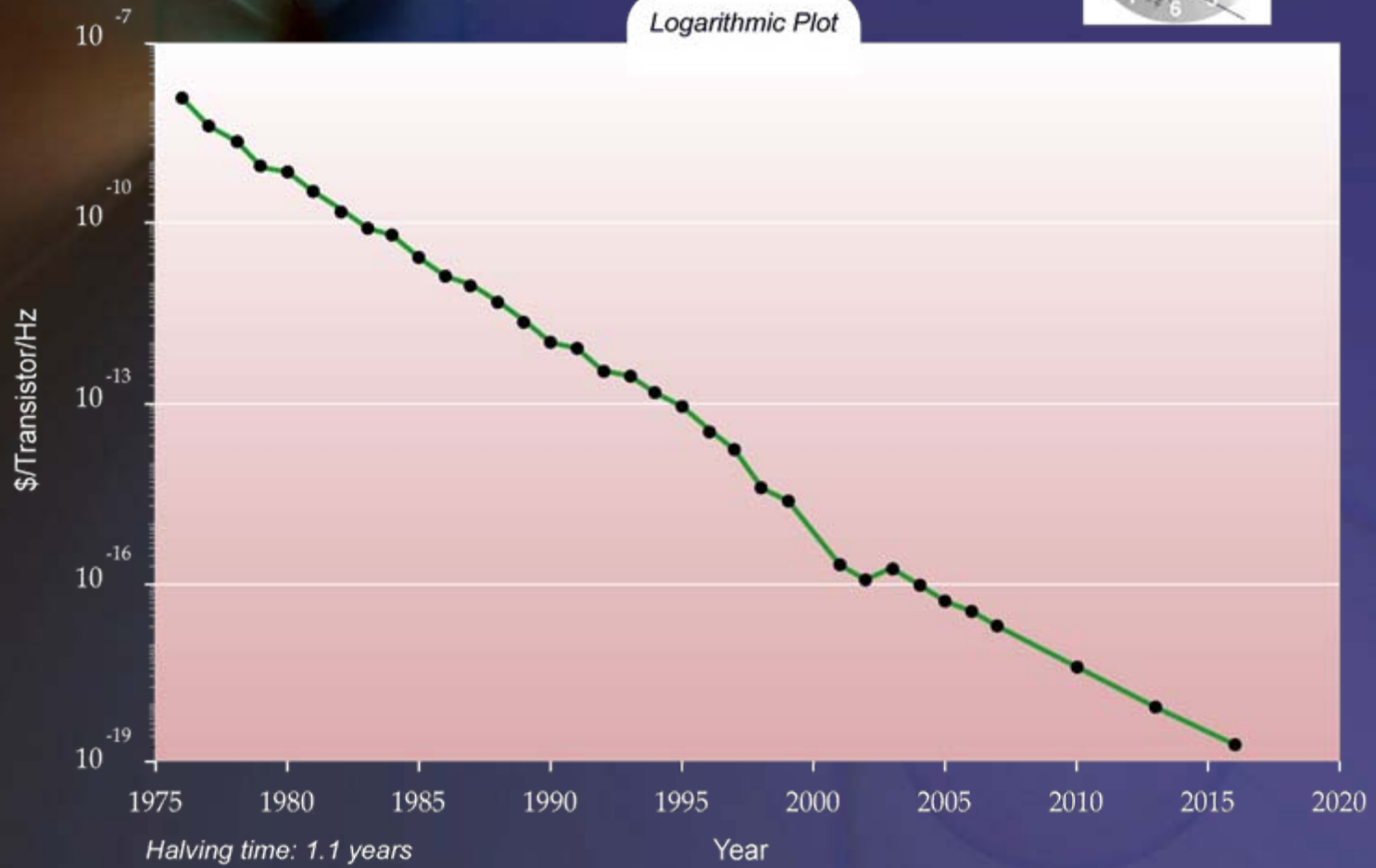



"Half Pitch" Feature Size

# Dynamic RAM Memory

Logarithmic Plot

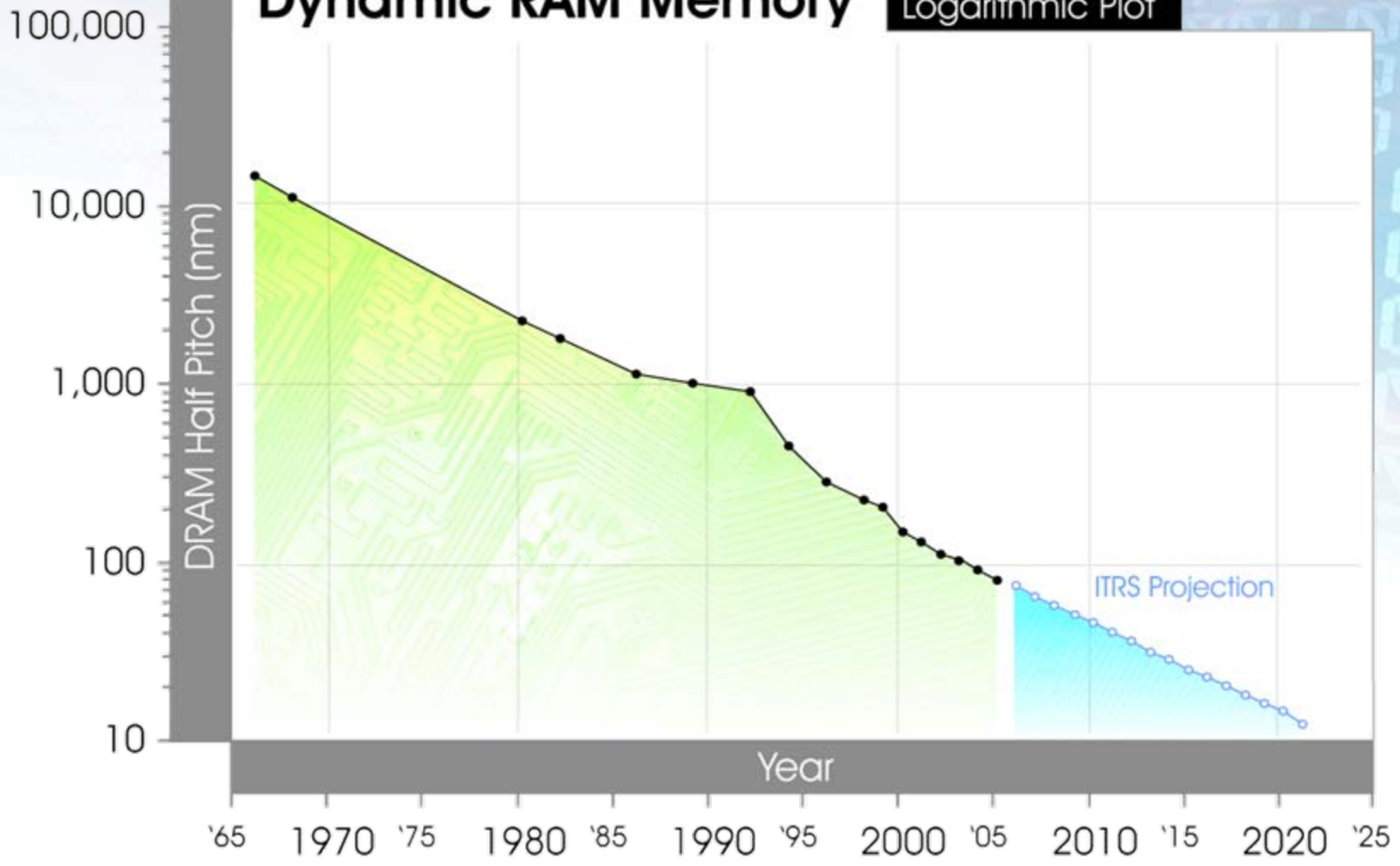

"Half Pitch" Feature Size

# Dynamic RAM Memory

Logarithmic Plot

100,000  
10,000  
1,000  
100  
10

DRAM Half Pitch (nm)

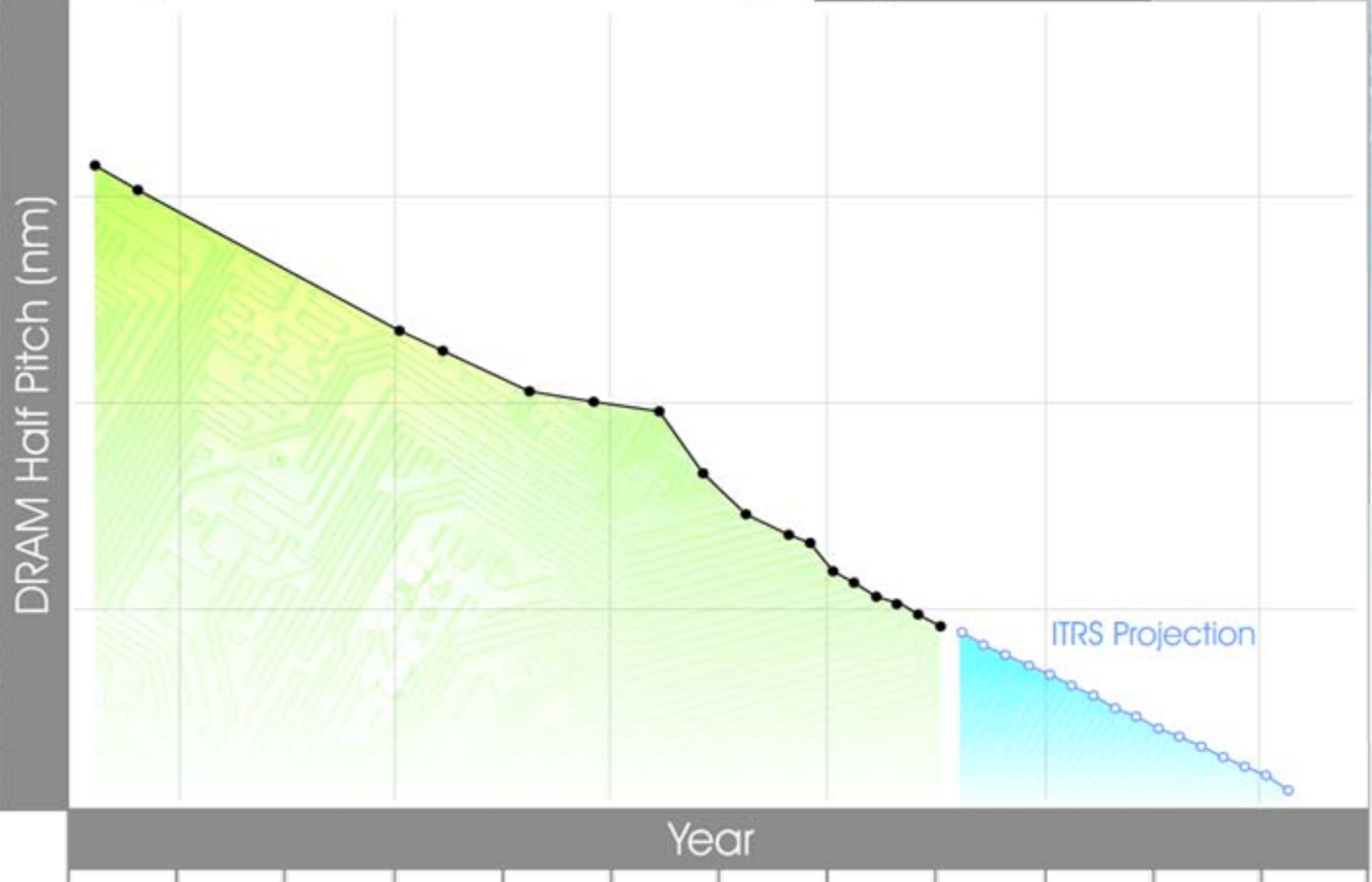

Year

'65 1970 '75 1980 '85 1990 '95 2000 '05 2010 '15 2020 '25

ITRS Projection

# Total Bits Shipped

Logarithmic Plot

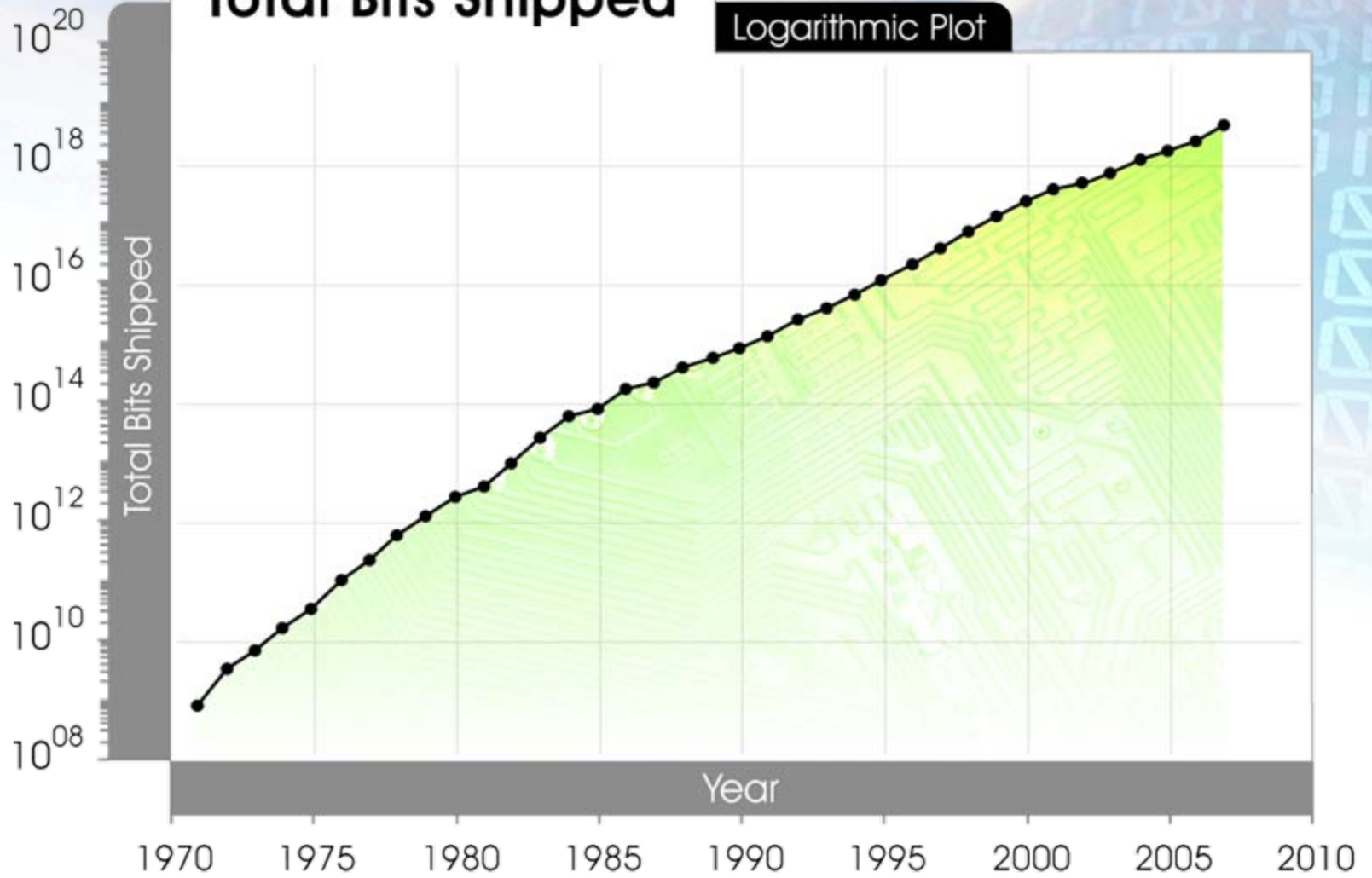

# Doubling (or Halving) times

- Dynamic RAM Memory “Half Pitch” Feature Size 5.4 years
- Dynamic RAM Memory (bits per dollar) 1.5 years
- Average Transistor Price 1.6 years
- Microprocessor Cost per Transistor Cycle 1.1 years
- Total Bits Shipped 1.1 years
- Processor Performance in MIPS 1.8 years
- Transistors in Intel Microprocessors 2.0 years
- Microprocessor Clock Speed 2.7 years

Bits per Dollar (Constant 2000 Dollars)

# Magnetic Data Storage

Logarithmic Plot

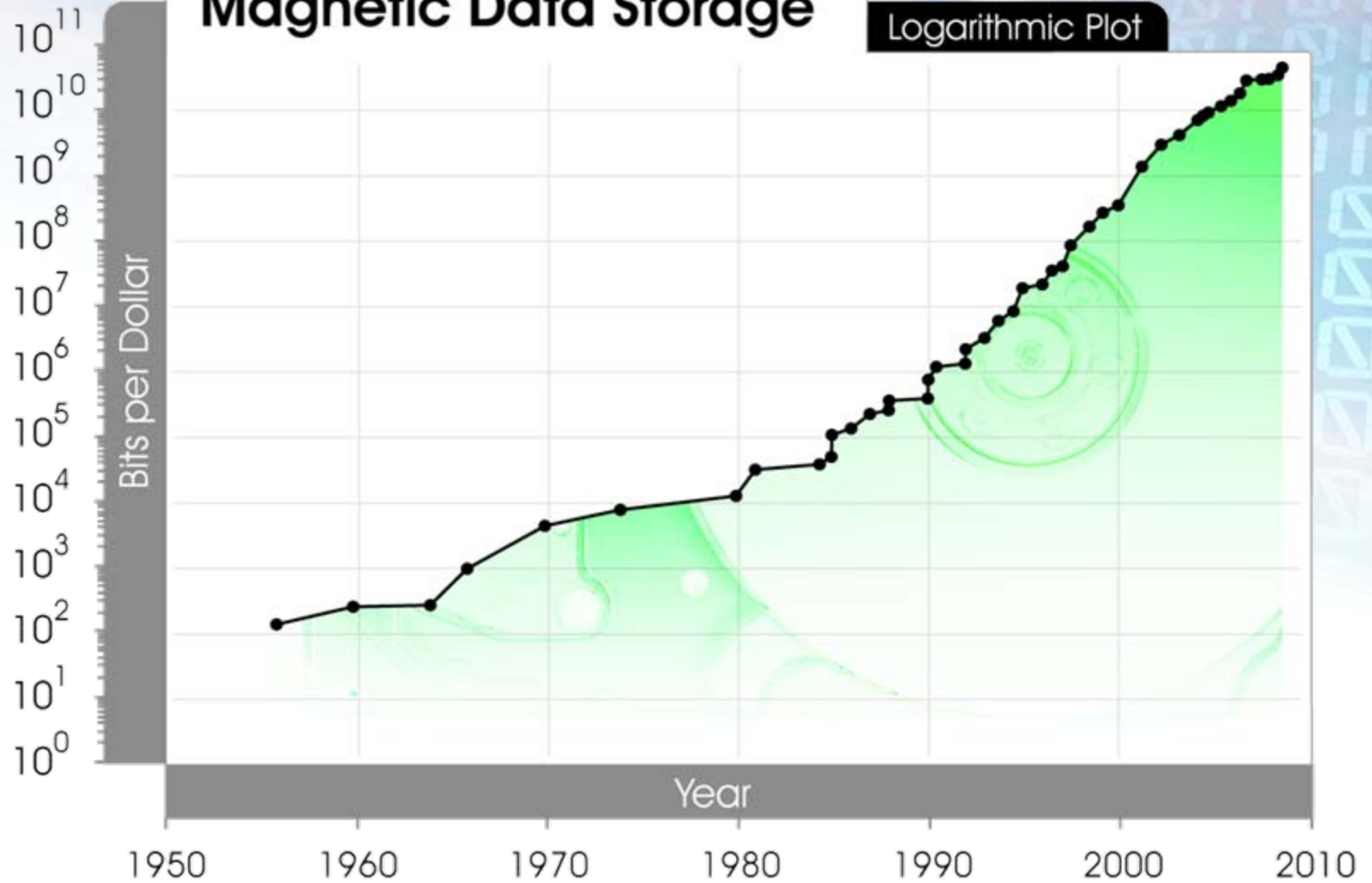



The Biotechnology revolution:  
the intersection of biology  
with information technology

# DNA Sequencing Cost

Logarithmic Plot

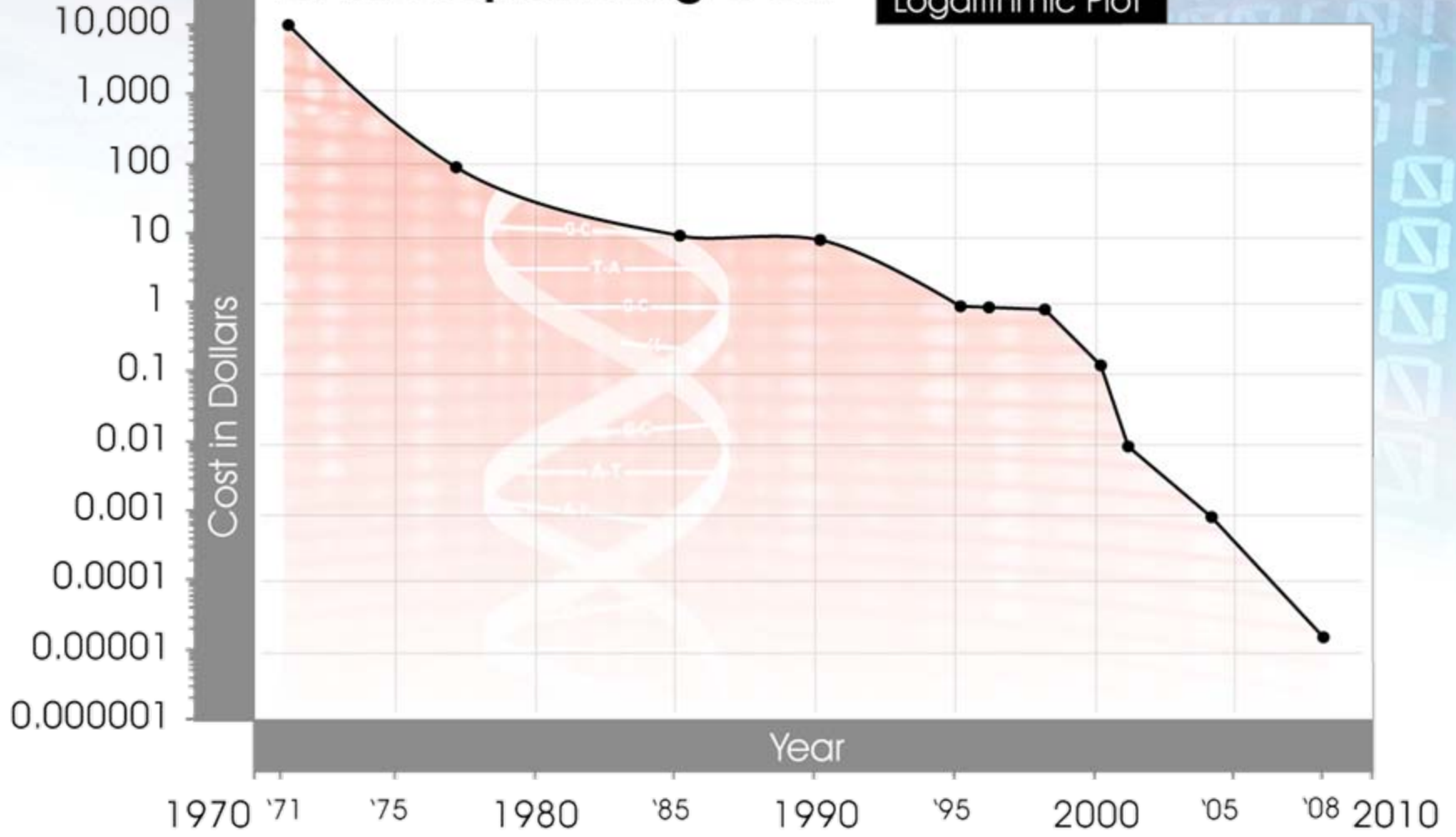

Growth in Genbank

# DNA Sequence Data

Logarithmic Plot

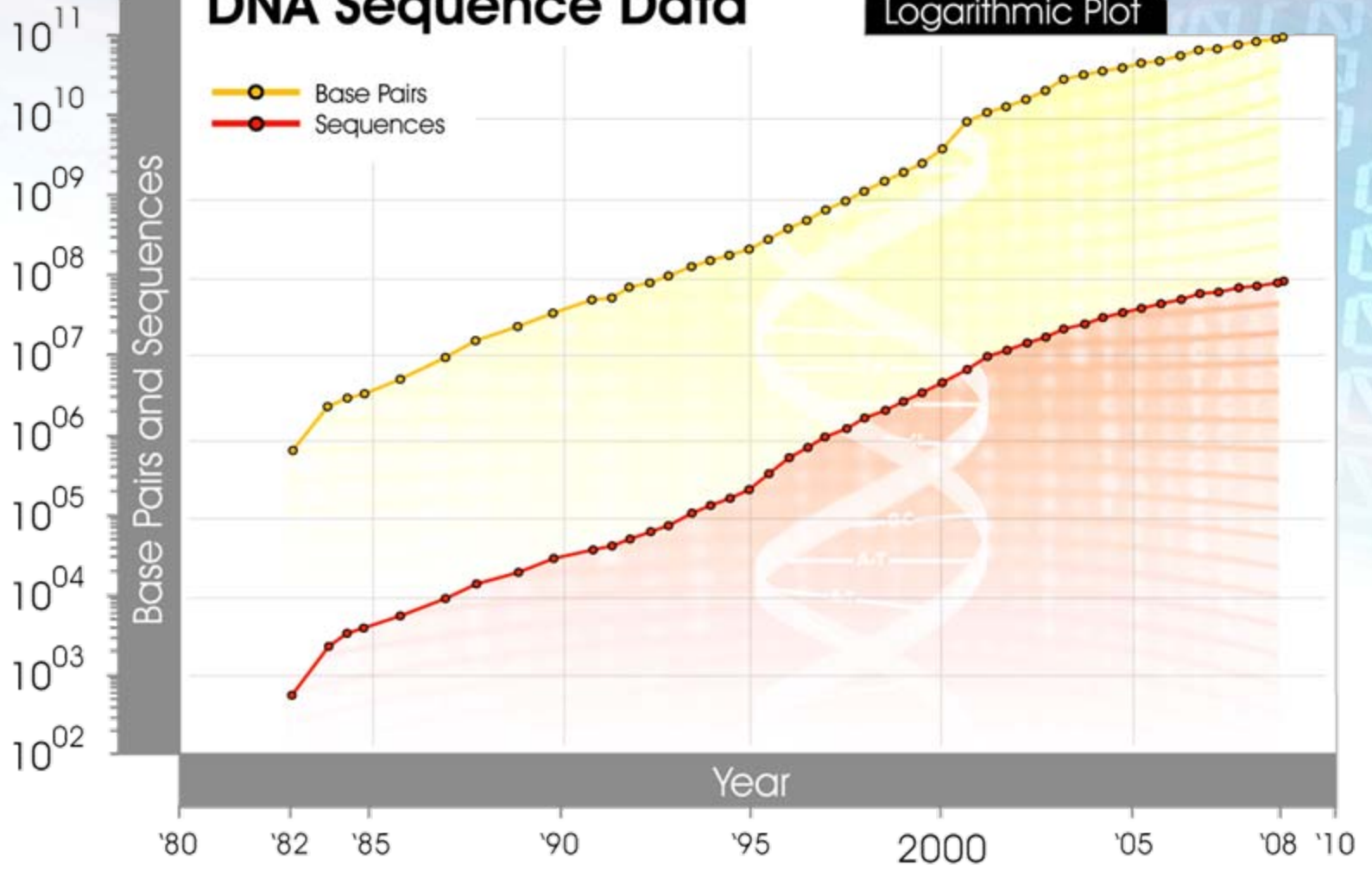



Every form of communications  
technology is doubling  
price-performance, bandwidth,  
capacity every 12 months

## Price-performance (wireless data devices)



# Internet Data Traffic (US)

Logarithmic Plot

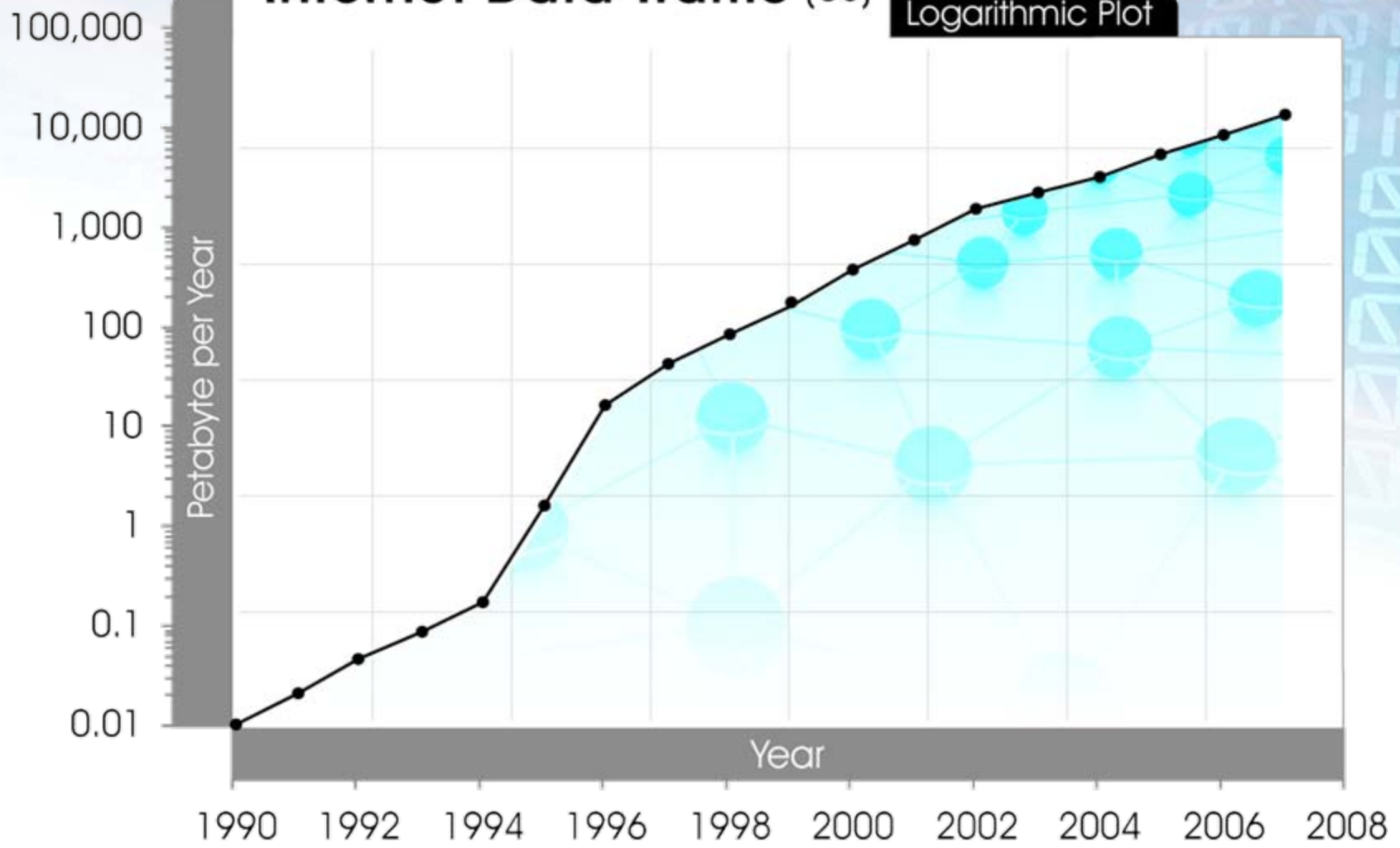

(Bits per Second)

# Internet Backbone Bandwidth

Logarithmic Plot

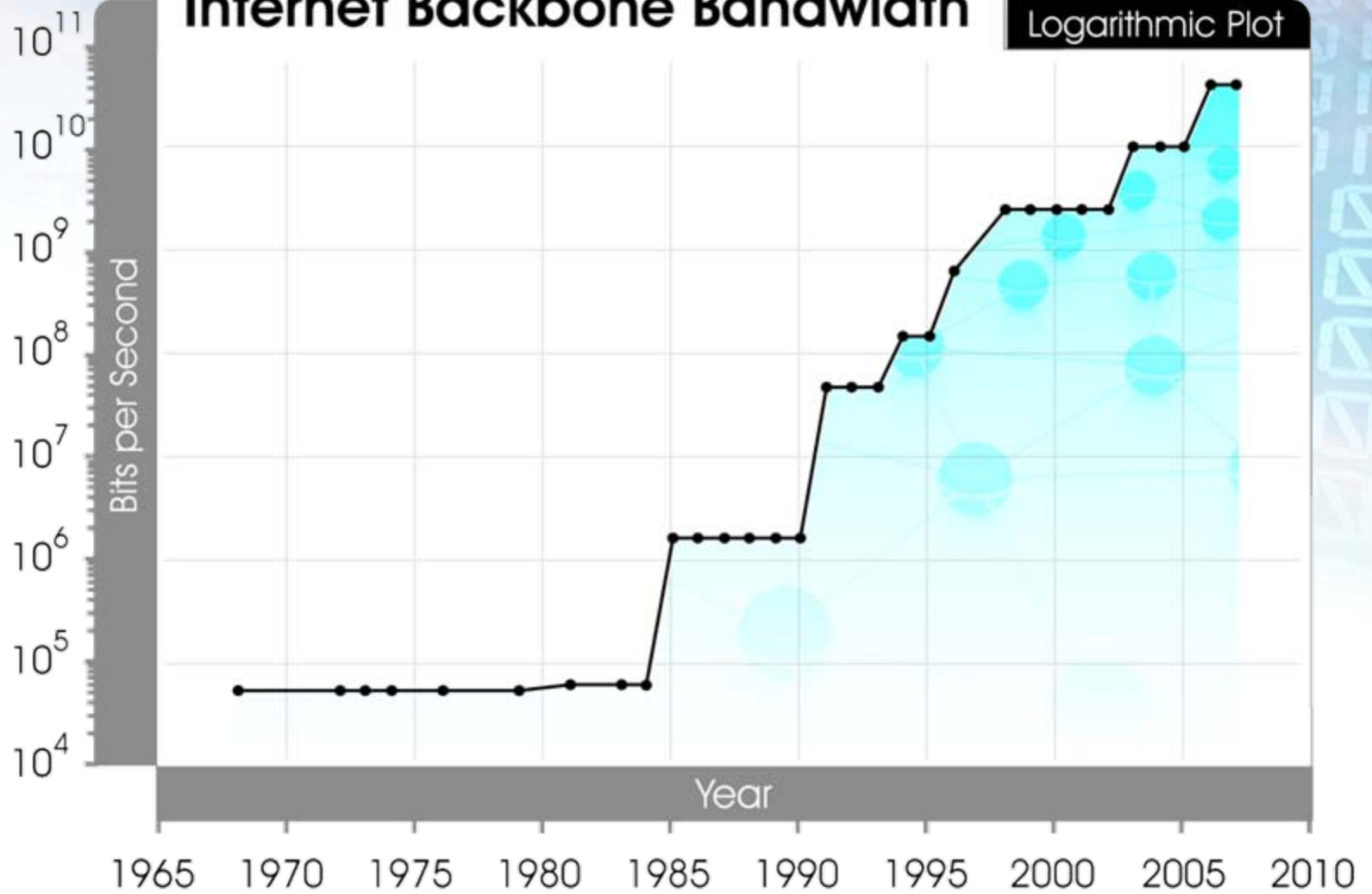

# Internet Hosts

Logarithmic Plot

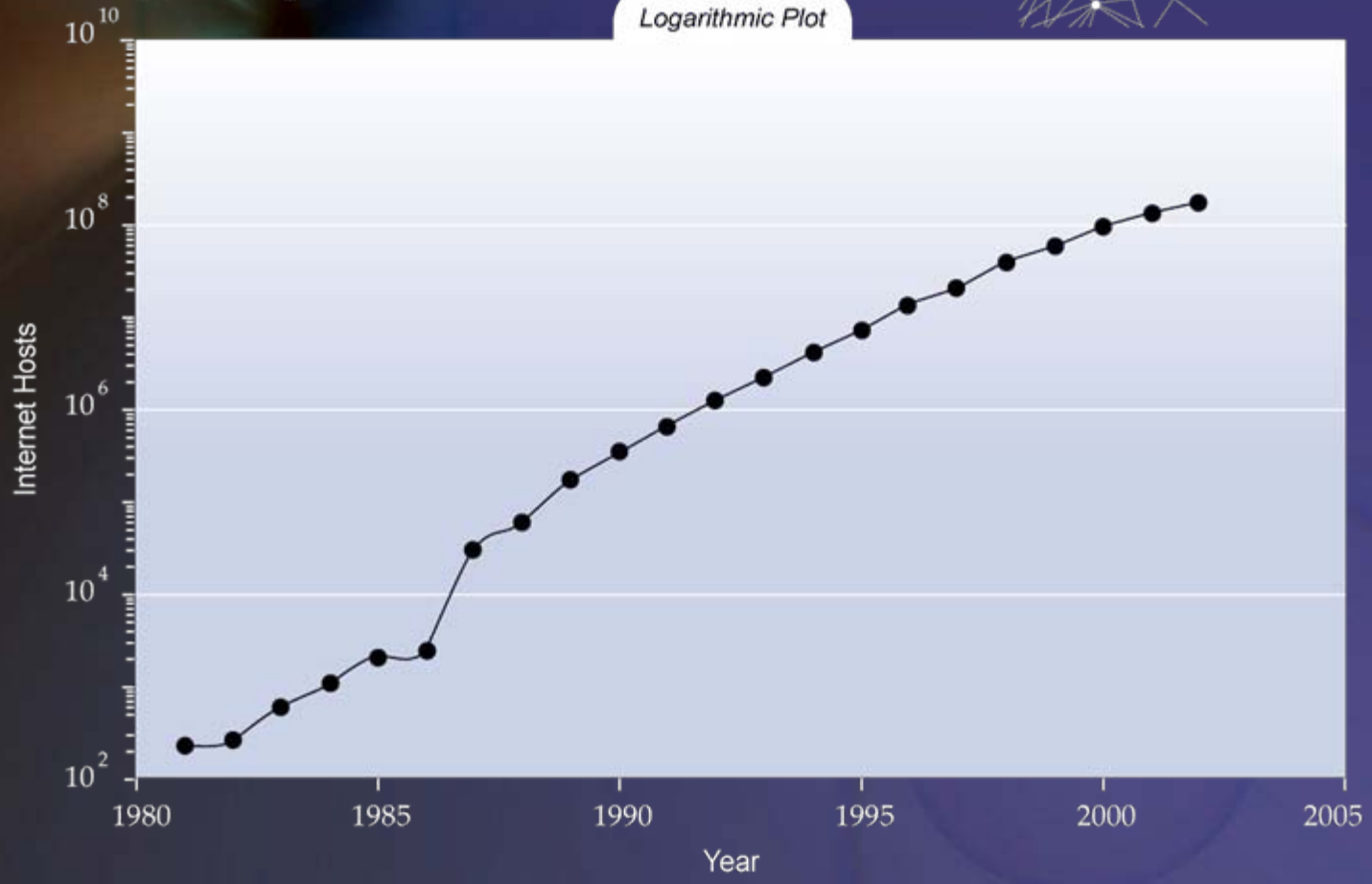

# Internet Hosts



Linear Plot

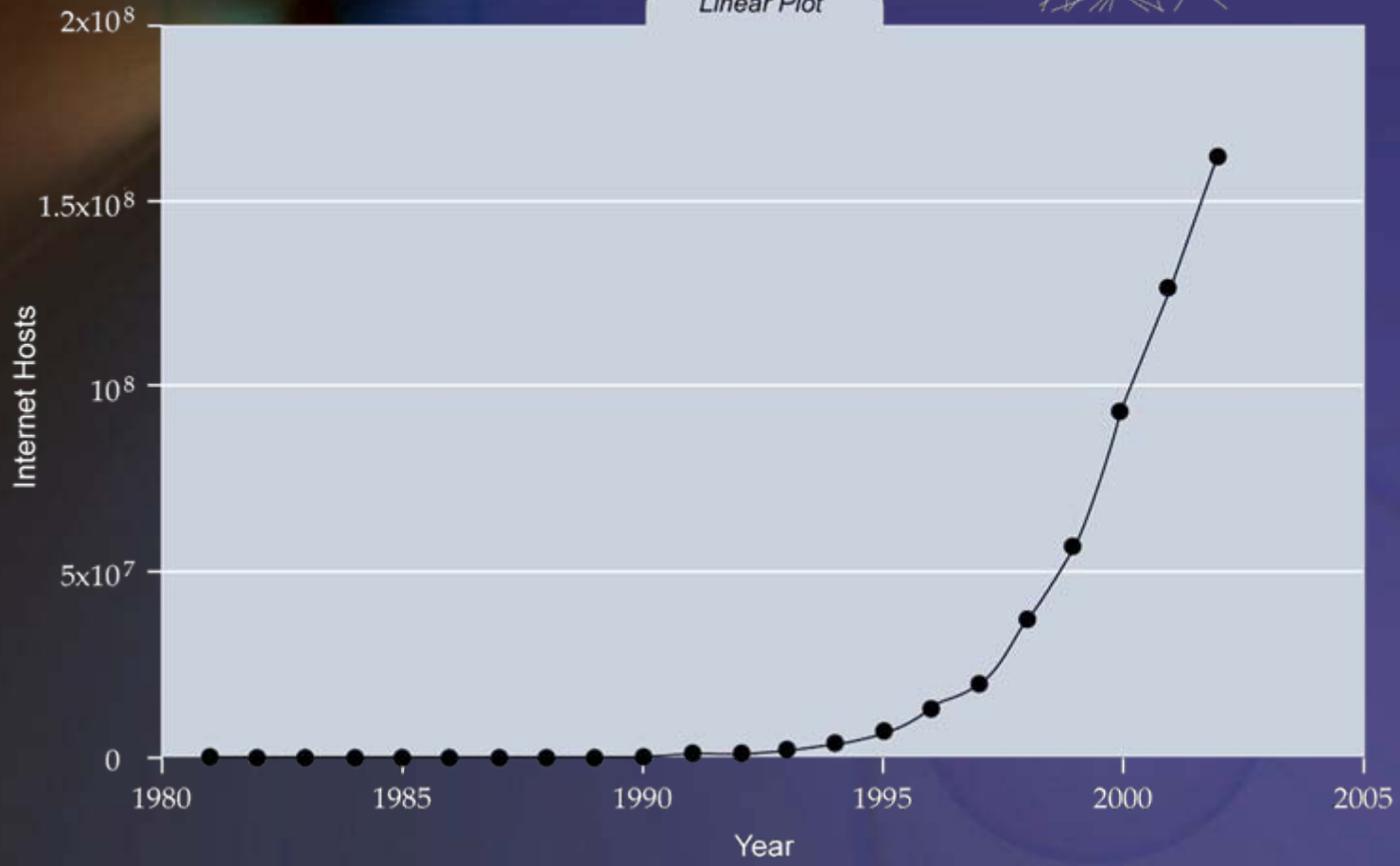



Miniaturization:  
another exponential trend

# Decrease in Size of Mechanical Devices (diameter in mm)



Logarithmic Plot

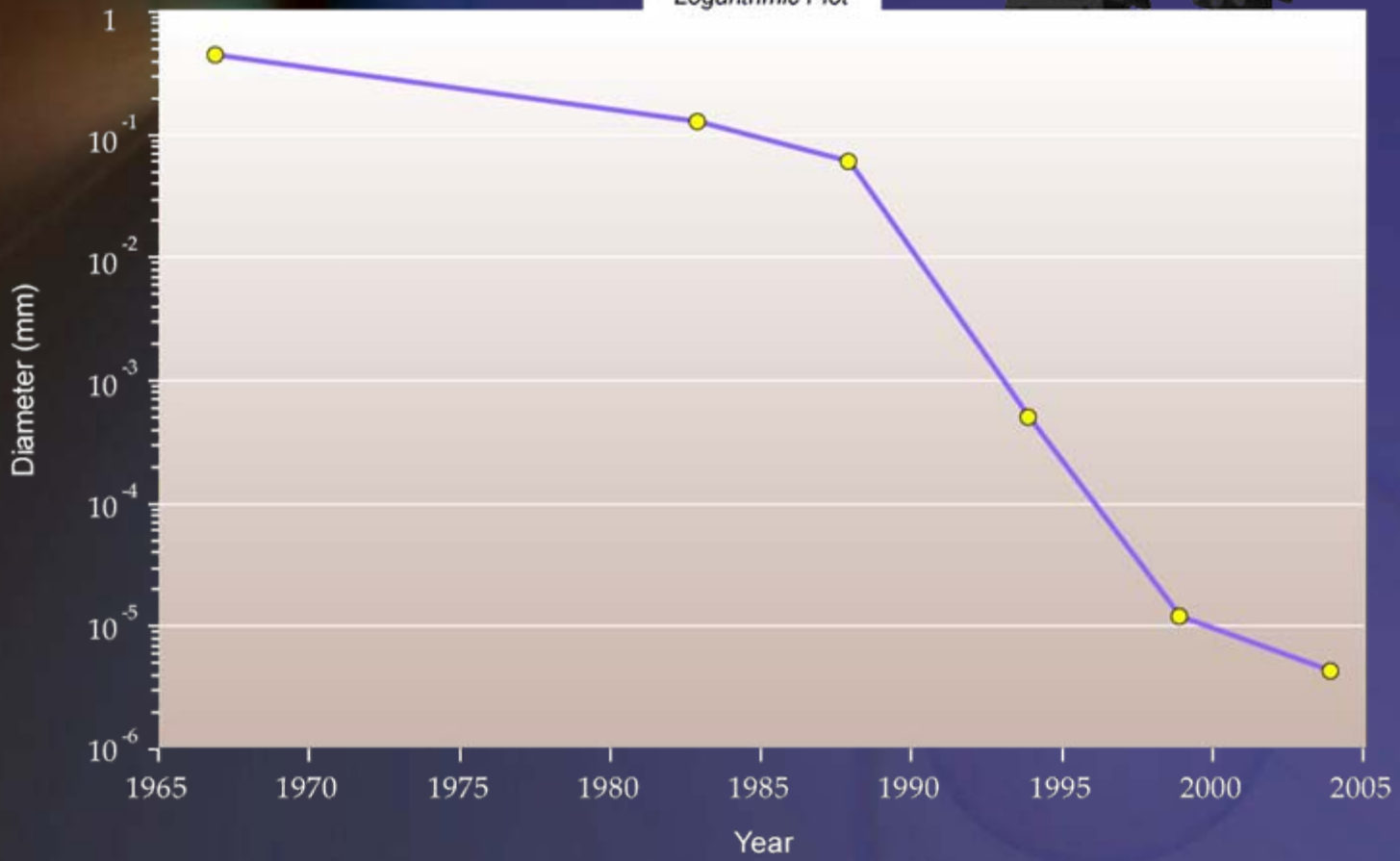

# Planetary Gear

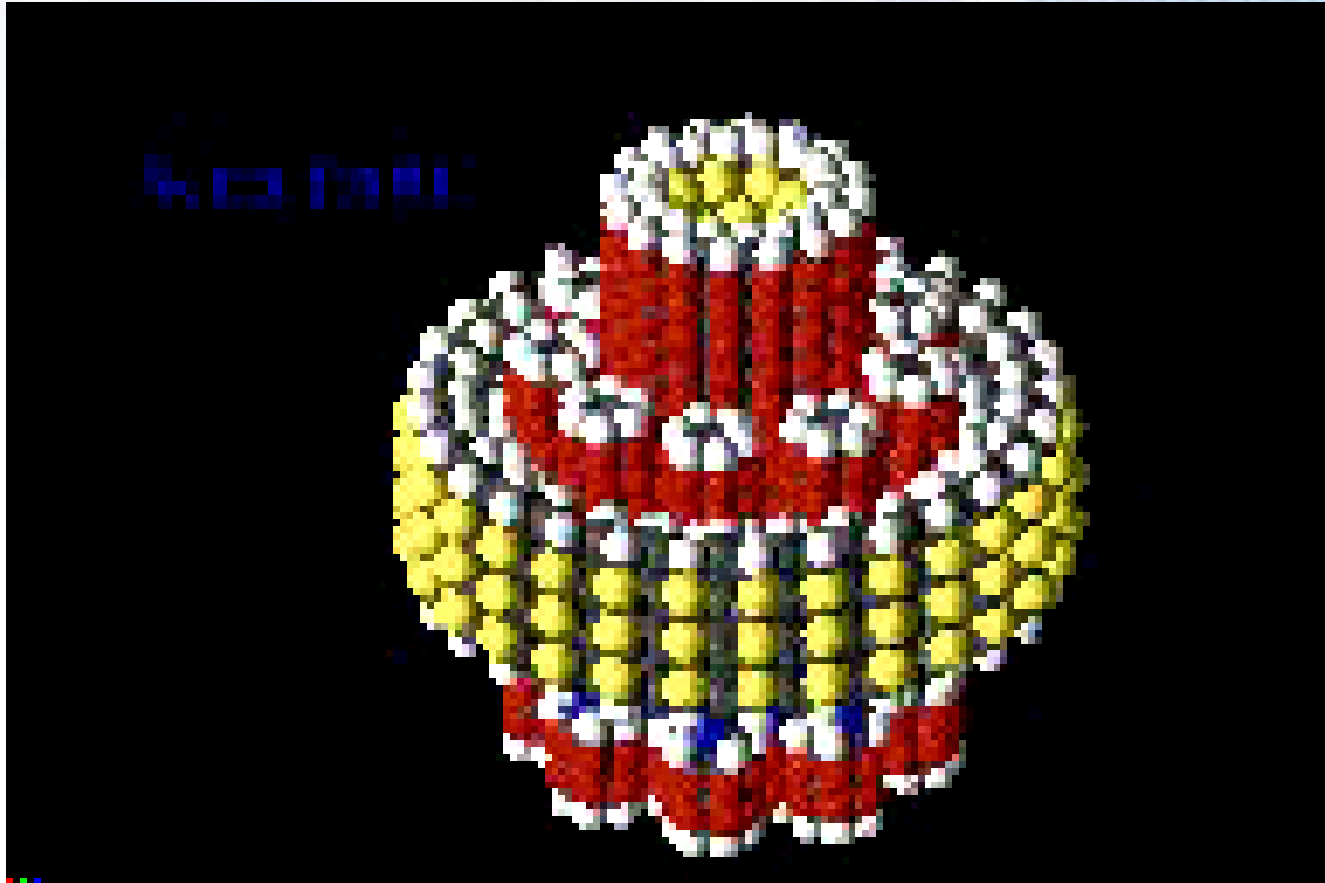

*Nanosystems bearing*

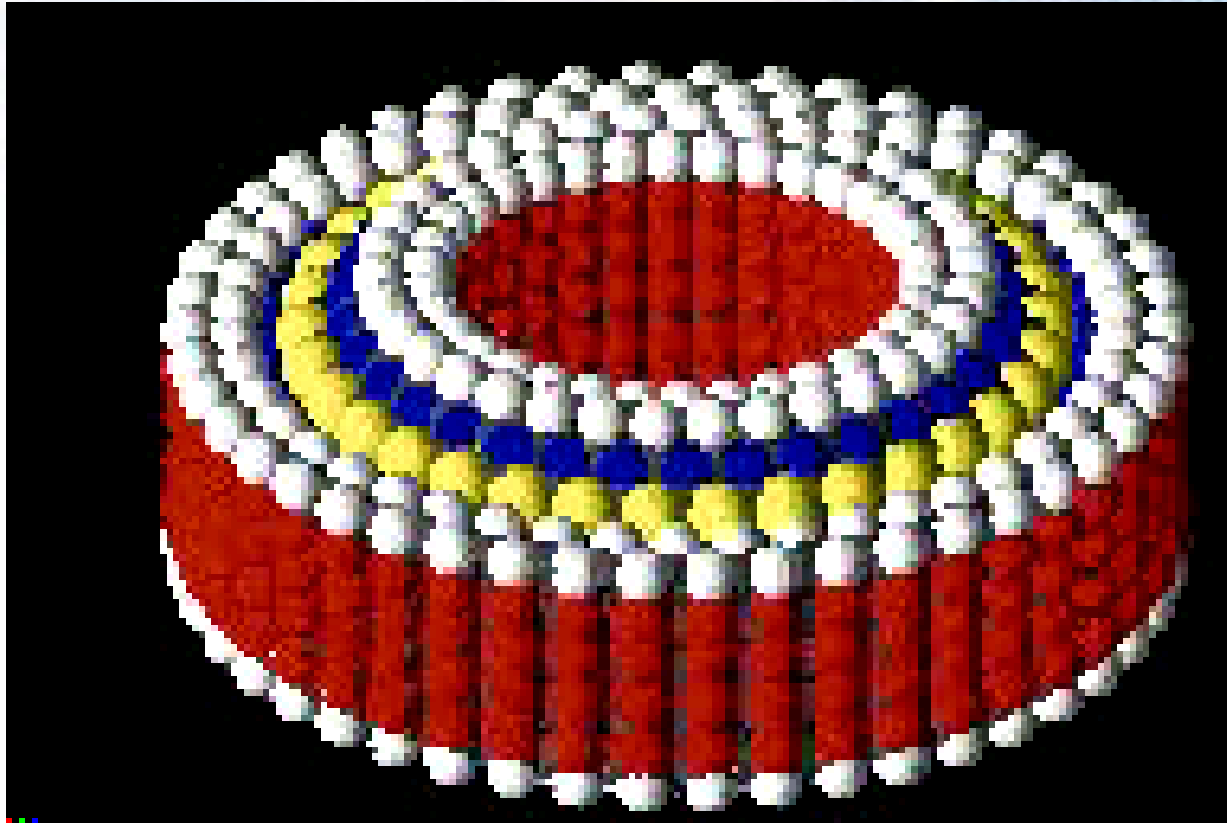

## *Nanosystems smaller bearing*

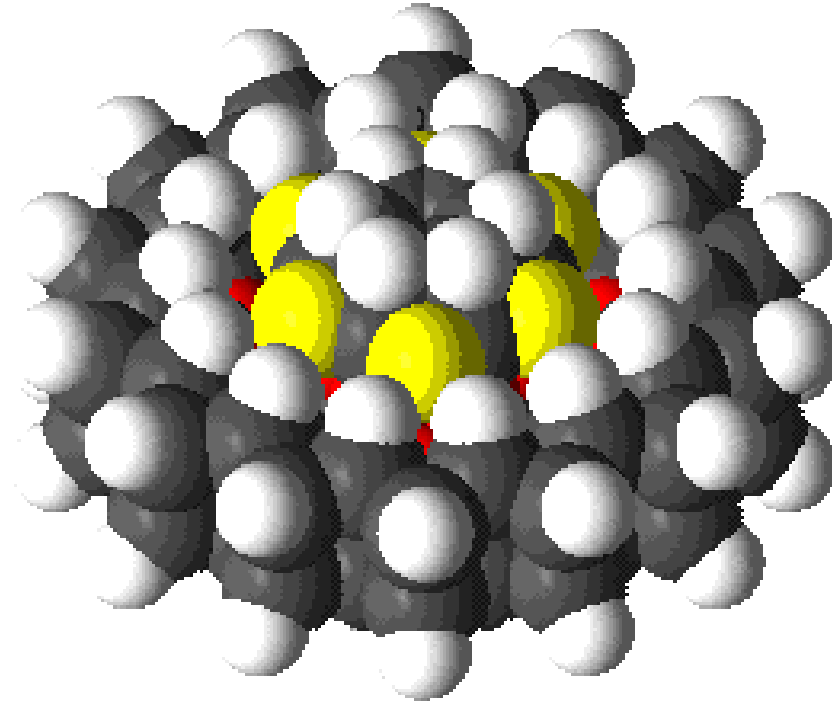

# Respirocyte

*(an artificial red blood cell)*

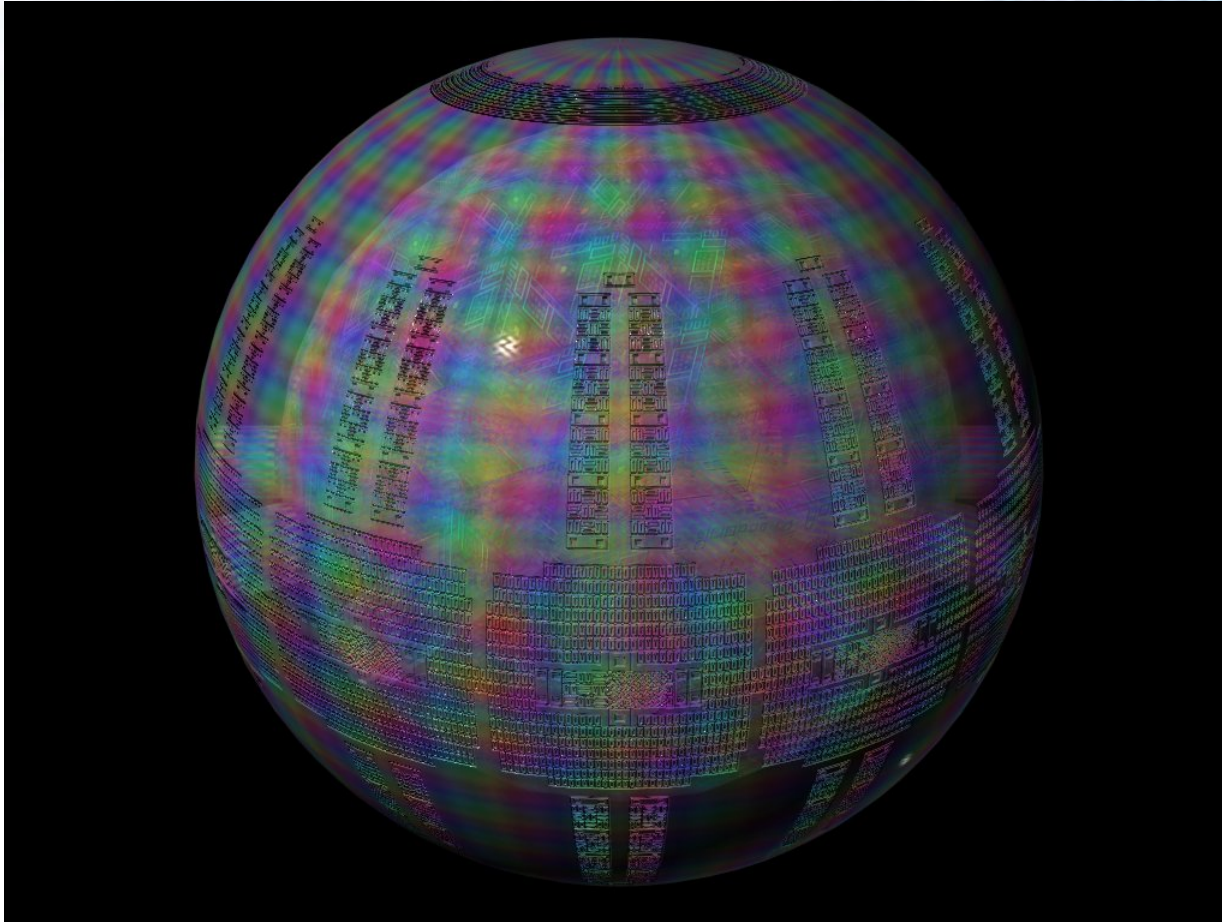

Copyright Vik Olliver, vik@asi.org.

# Respirocytes with Red Cells

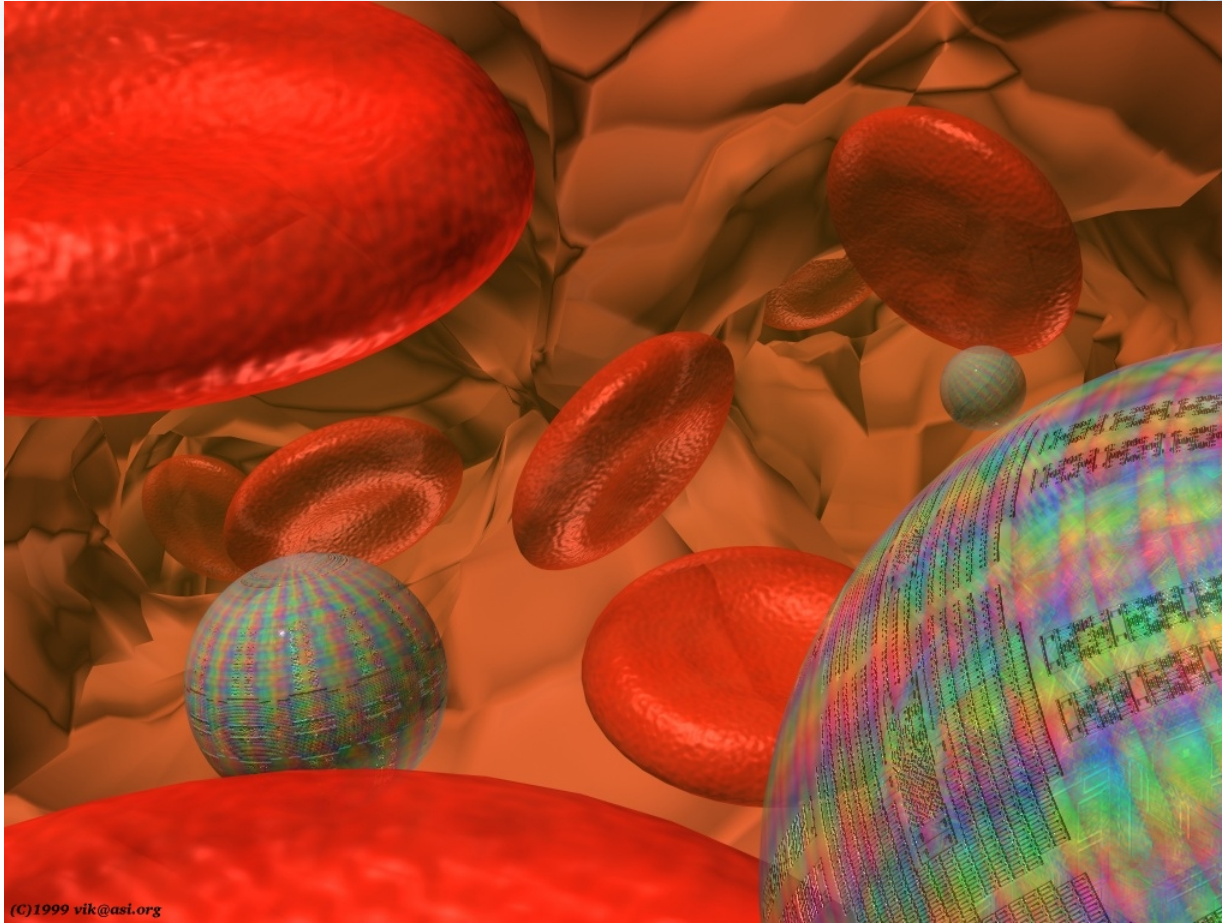

Copyright Vik Olliver, vik@asi.org.

# Animation of a respirocyte releasing oxygen in a capillary



Copyright 2001, Lawrence Fields, Jillian Rose, and Phlesch Bubble Productions.

High resolution still from  
the animation of a respirocyte

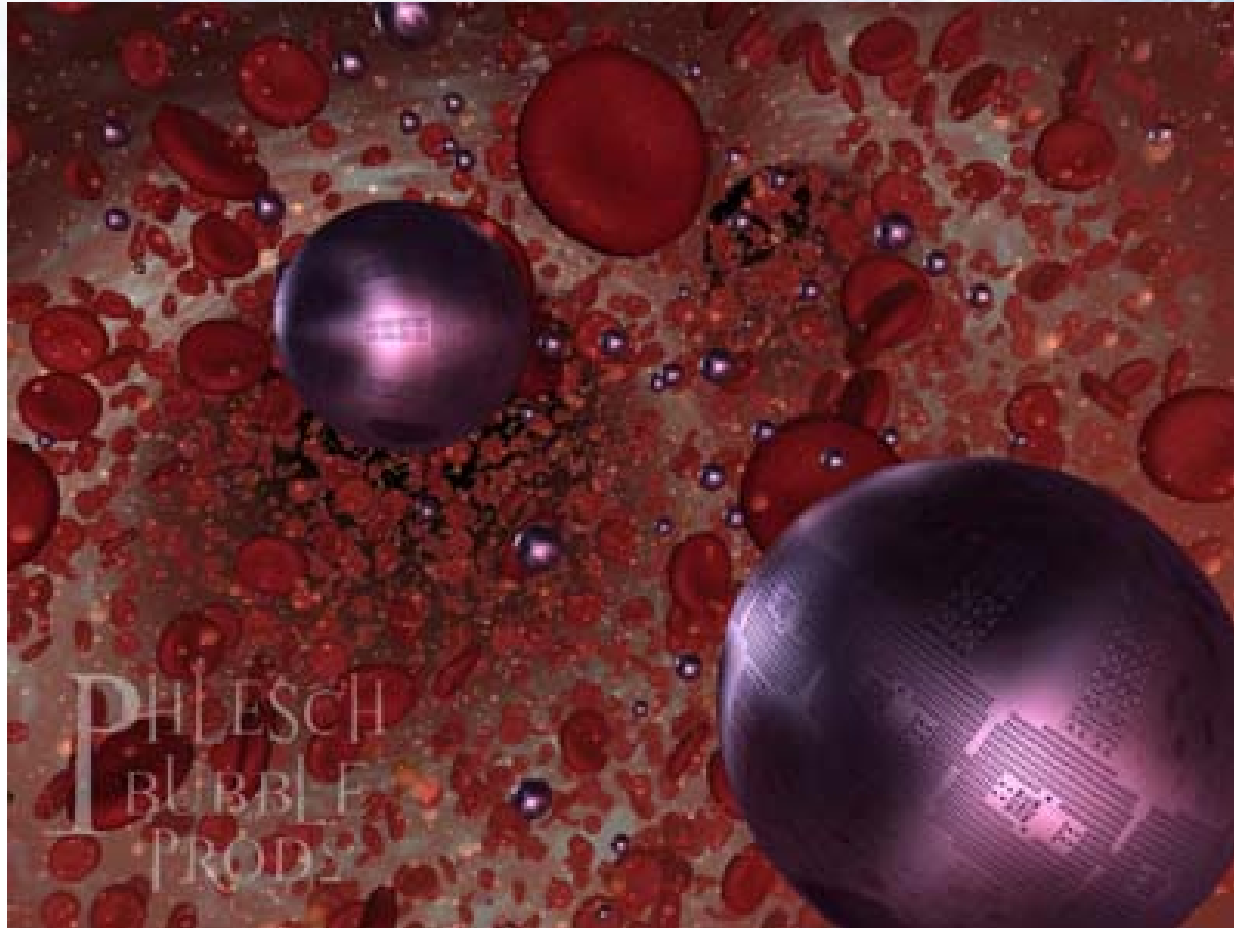

## Microbivores II

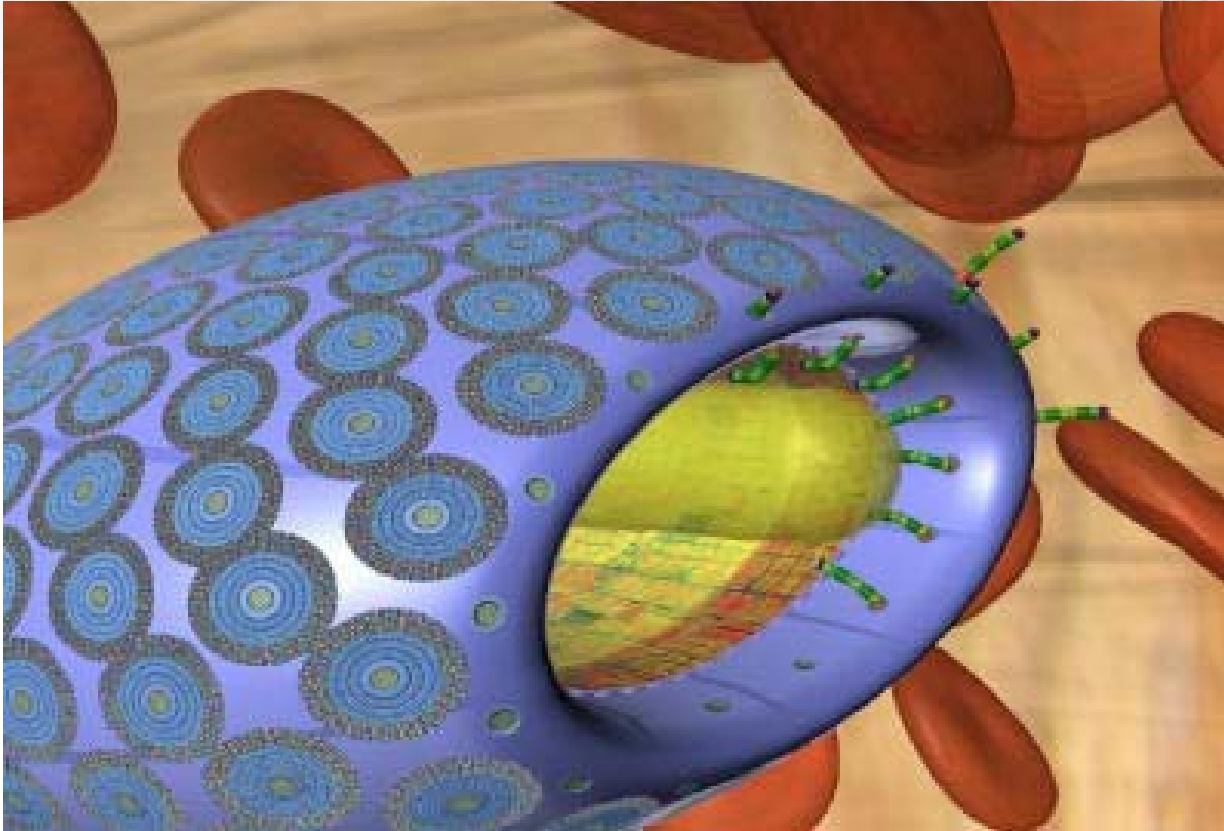

Copyright Zyvex (Katherine Green)

# Nanotech Science Citations (1990-2002)

Logarithmic Plot

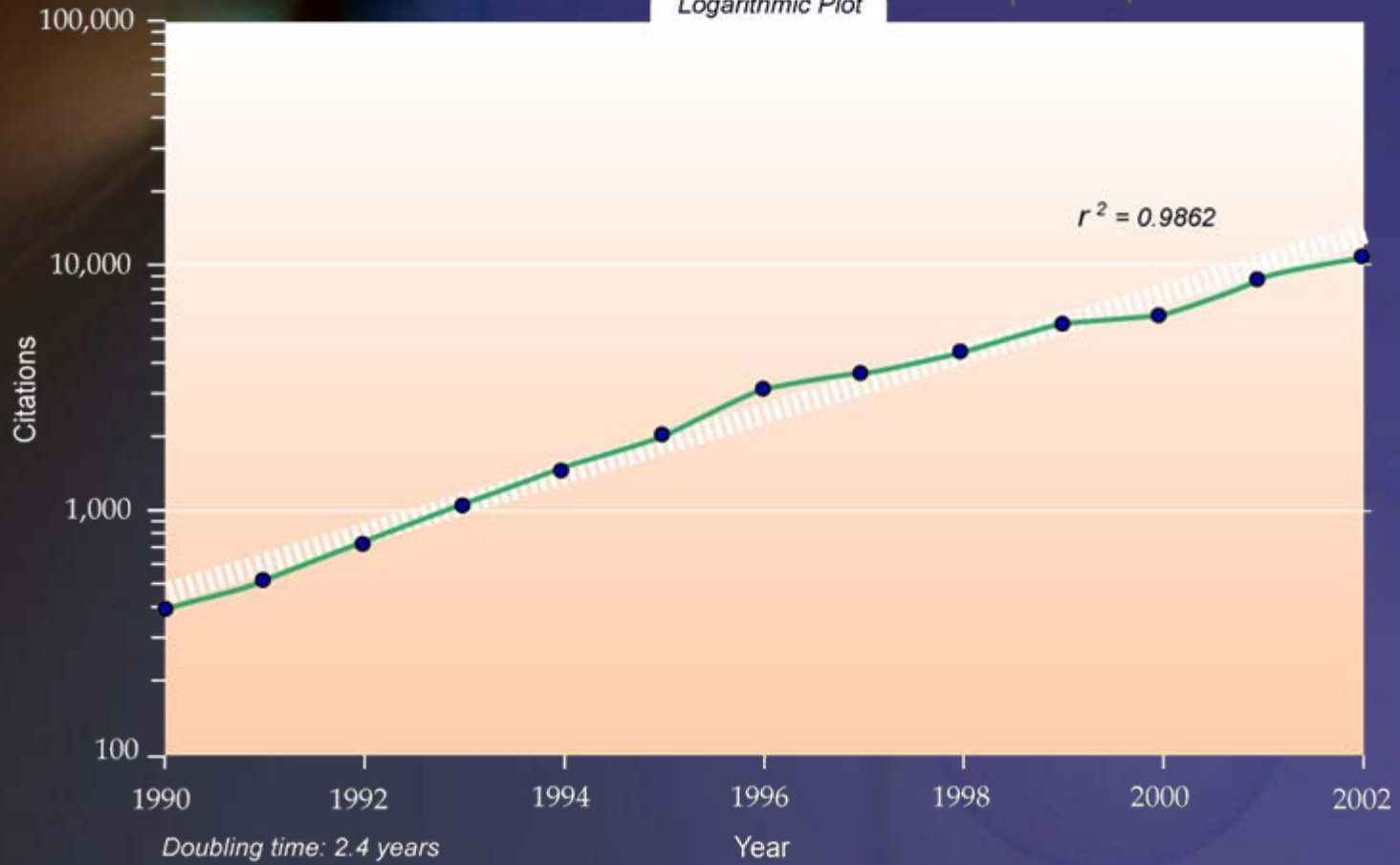
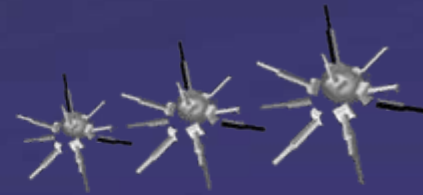

## U.S. Nanorelated Patents

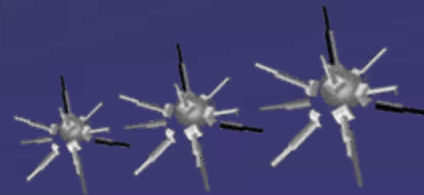

Logarithmic Plot

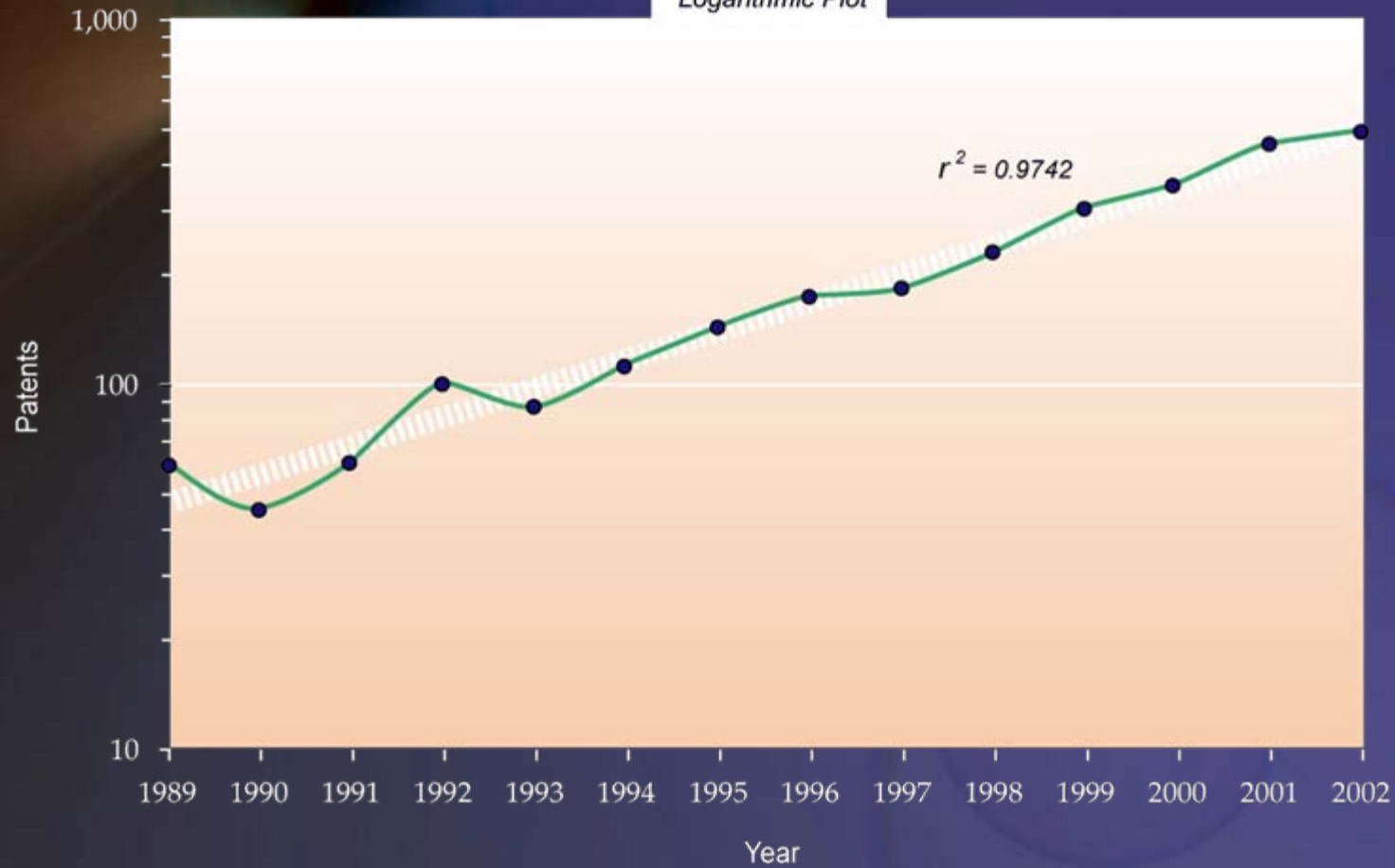

# Exponential Growth of Computing

The exponential growth of computing is a marvelous quantitative example of the exponentially growing returns from an evolutionary process. We can express the exponential growth of computing in terms of its accelerating pace: it took 90 years to achieve the first MIPS per 1000 dollars; now we add 1.2 MIPS per 1000 dollars every hour.

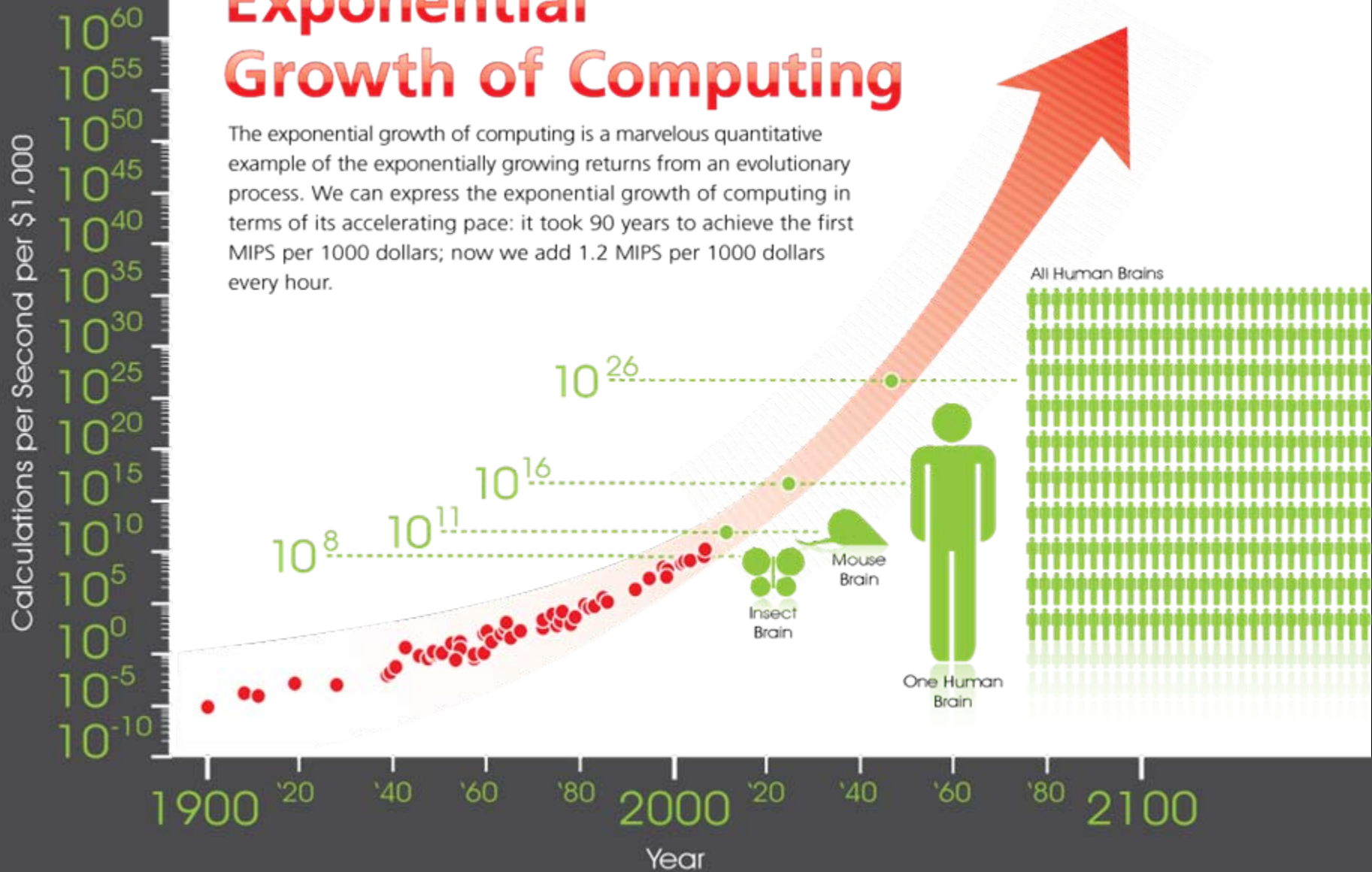

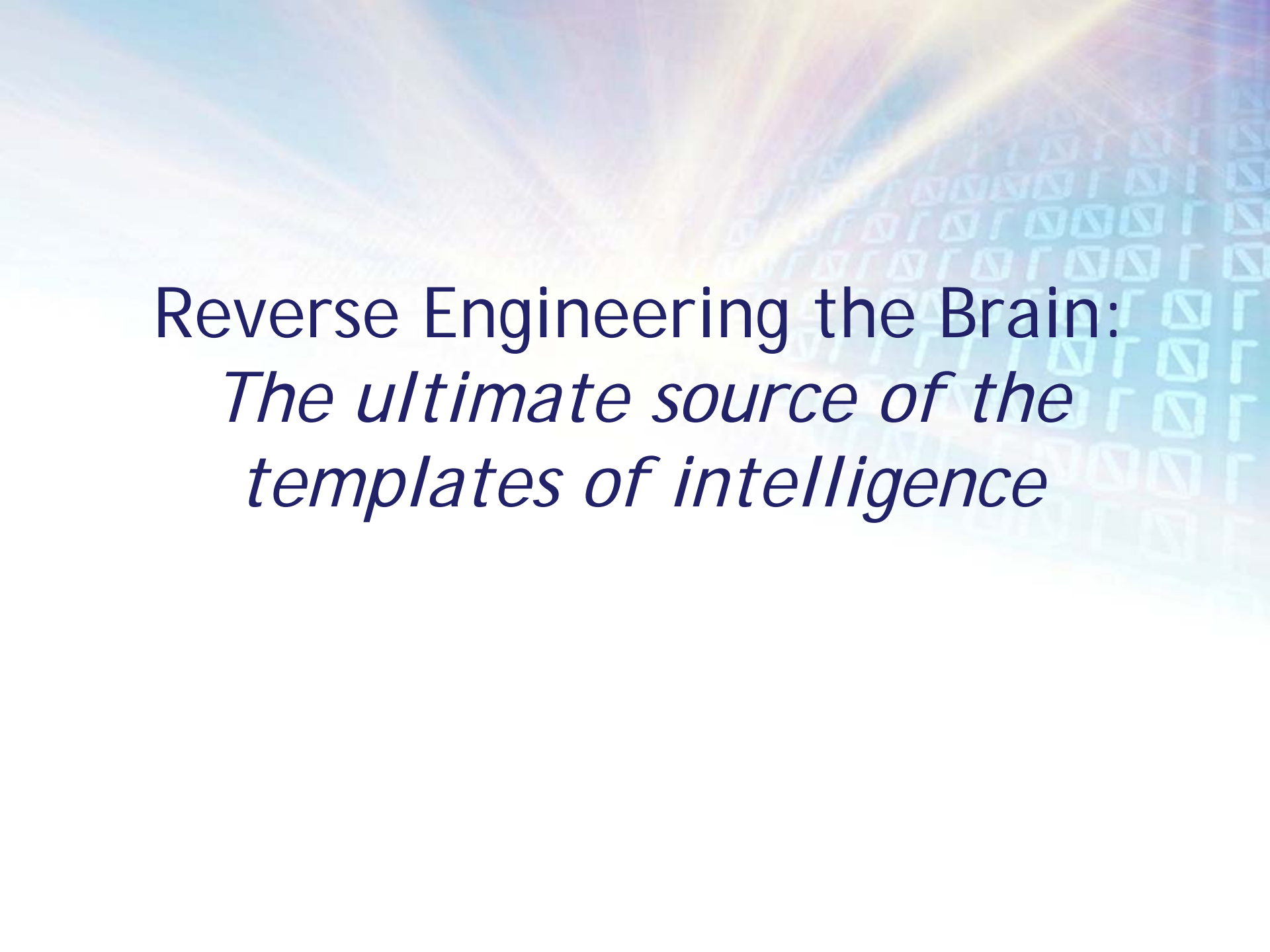
The background features a grid of binary code (0s and 1s) in a light blue color, set against a backdrop of soft, multi-colored light rays in shades of blue, purple, and yellow, creating a futuristic and digital atmosphere.

Reverse Engineering the Brain:  
*The ultimate source of the  
templates of intelligence*

# The (converging) Sources of the Templates of Intelligence

- AI research
- Reverse Engineering the Brain
- Research into performance of the brain (human thought)
  - Language: an ideal laboratory for studying human ability for hierarchical, symbolic, recursive thinking
- All of these expand the AI tool kit

# Resolution of Noninvasive Brain Scanning



Logarithmic Plot

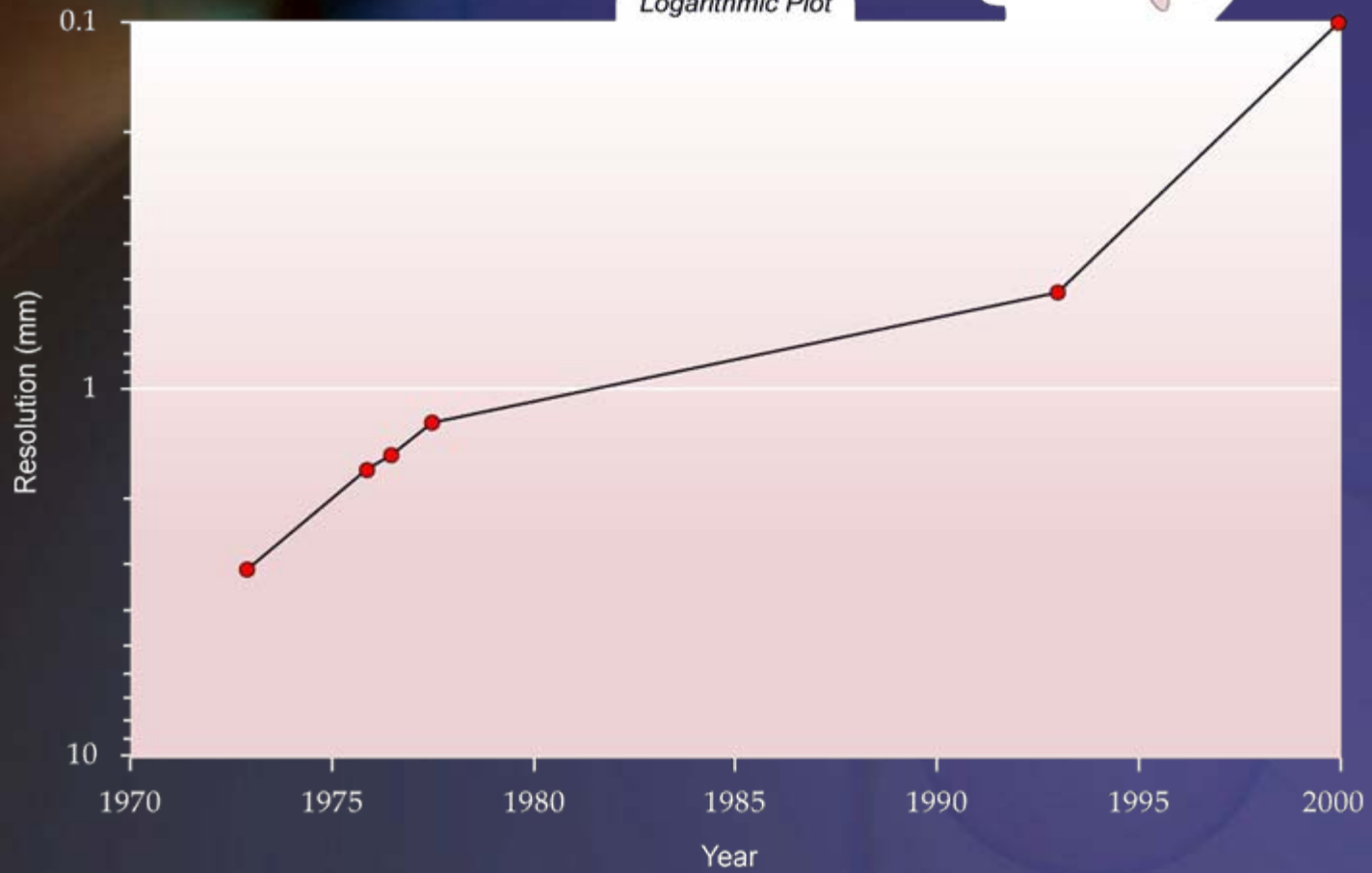

# Brain Scanning Image Reconstruction Time (seconds)



Logarithmic Plot

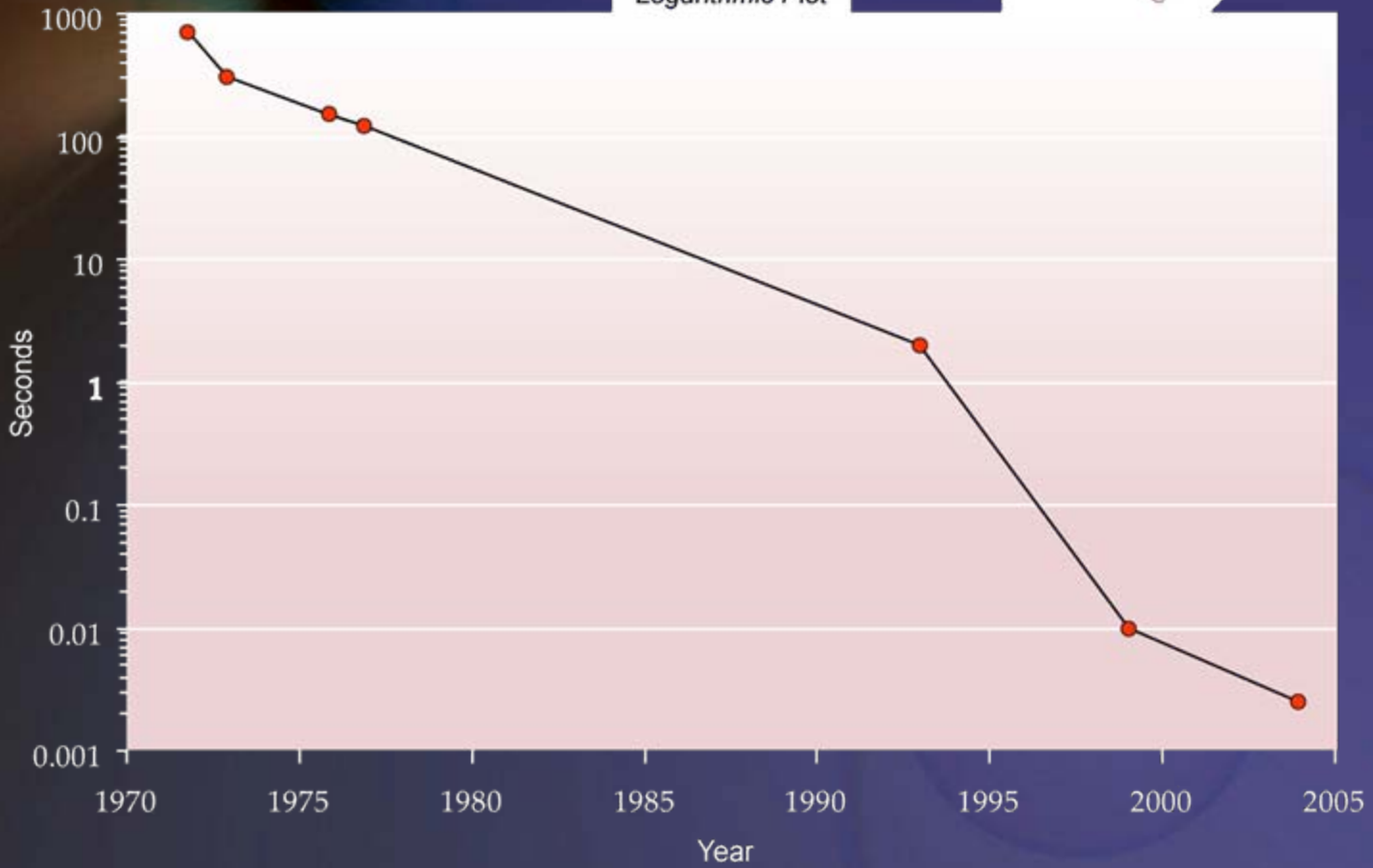

# Reverse Engineering the Human Brain:

## Five Parallel Auditory Pathways

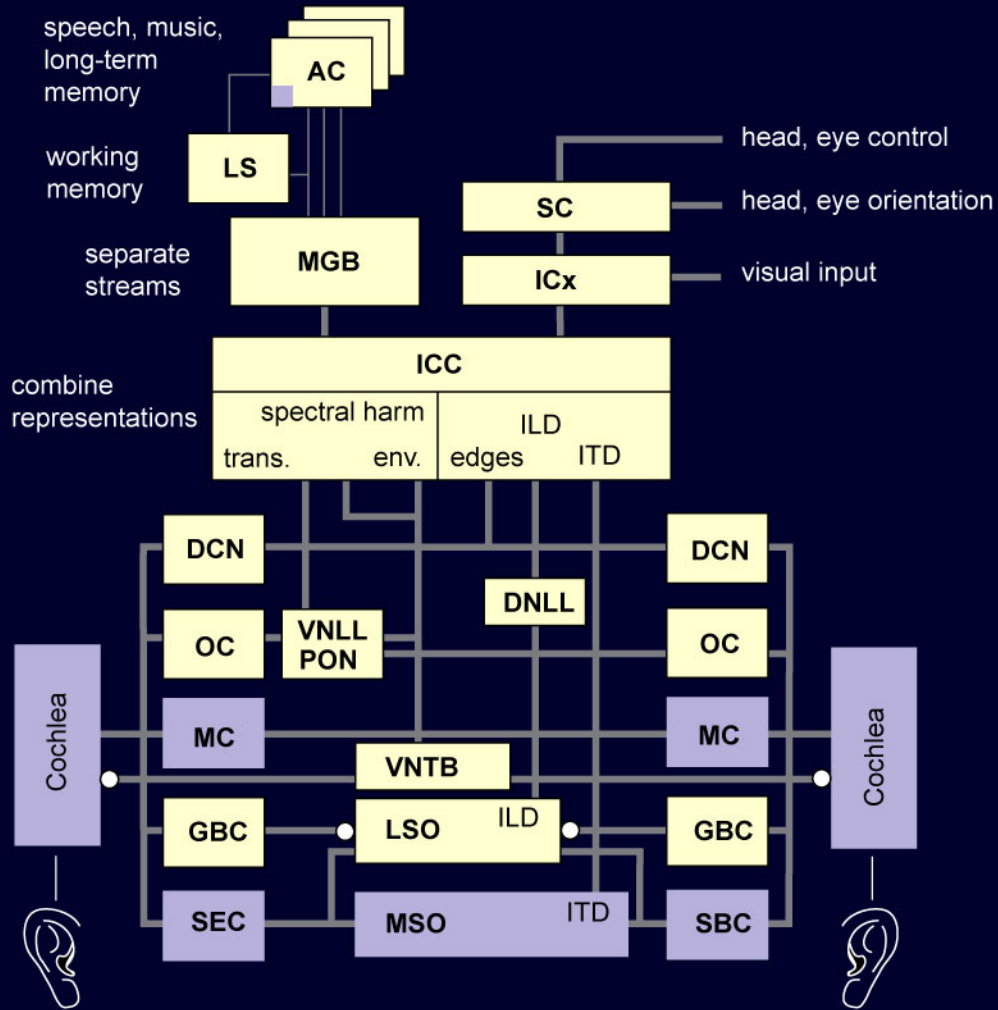

*"Now, for the first time, we are observing the brain at work in a global manner with such clarity that we should be able to discover the overall programs behind its magnificent powers."*

*-- J.G. Taylor, B. Horwitz, K.J. Friston*

# Ways that the brain differs from a conventional computer:

- Very few cycles available to make decisions
- Massively parallel: 100 trillion interneuronal connections
- Combines digital & analog phenomena at every level
  - Nonlinear dynamics can be modeled using digital computation to any desired degree of accuracy
  - Benefits of modeling using transistors in their analog native mode

# Ways that the brain differs from a conventional computer:

- The brain is self-organizing at every level
- Great deal of stochastic (random within controlled constraints) process in every aspect
  - Self-organizing, stochastic techniques are routinely used in pattern recognition
- Information storage is holographic in its properties

# The brain's design is a level of complexity we can manage

- Only about 20 megabytes of compressed design information about the brain in the genome
  - A brain has ~ billion times more information than the genome that describes its design
- The brain's design is a probabilistic fractal
- We've already created simulations of ~ 20 regions (out of several hundred) of the brain

# Mandelbrot Set Image

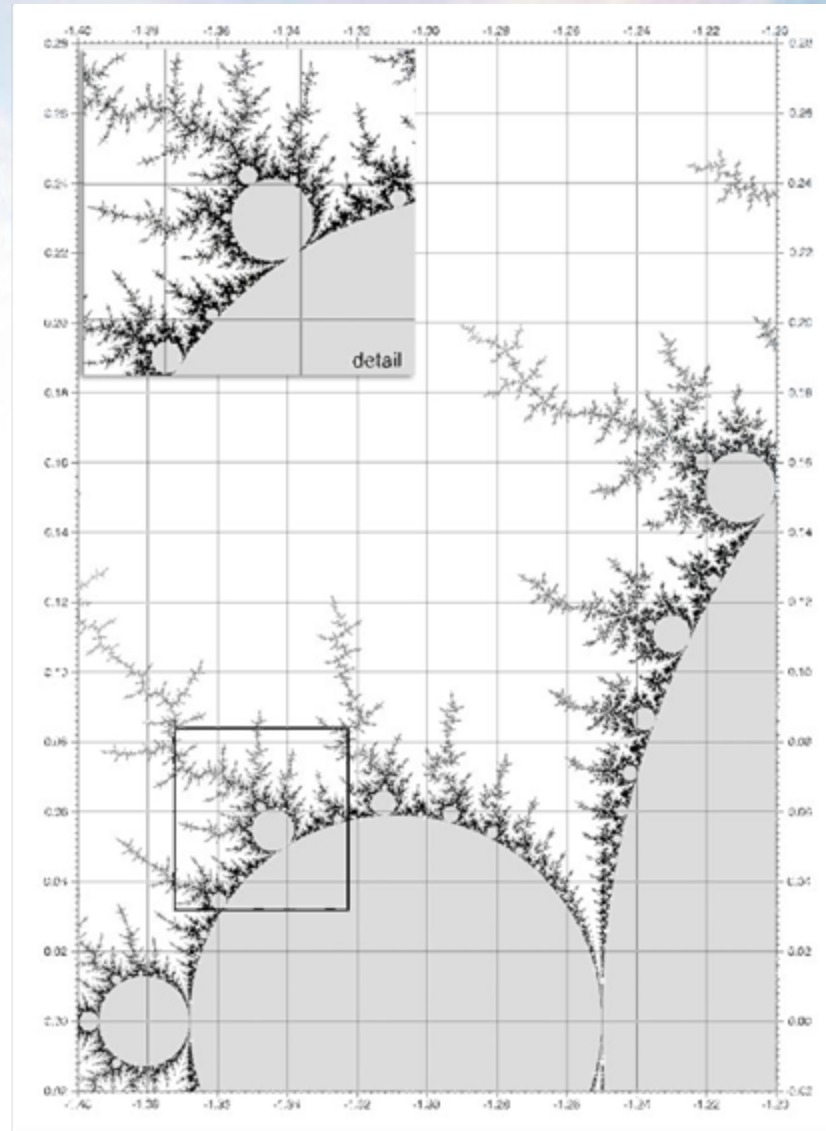

# Models often get simpler at a higher level, not more complex

- Consider an analogy with a computer
  - We do need to understand the detailed physics of semiconductors to model a transistor, and the equations underlying a single real transistor are complex.
  - A digital circuit that multiplies two numbers, however, although involving hundreds of transistors, can be modeled far more simply.

# Modeling Systems at the Right Level

- Although chemistry is theoretically based on physics, and could be derived entirely from physics, this would be unwieldy and infeasible in practice.
- So chemistry uses its own rules and models.
- We should be able to deduce the laws of thermodynamics from physics, but this is far from straightforward.
  - Once we have a sufficient number of particles to call it a gas rather than a bunch of particles, solving equations for each particle interaction becomes hopeless, whereas the laws of thermodynamics work quite well.

# Modeling Systems at the Right Level

- The same issue applies to the levels of modeling and understanding in the brain - from the physics of synaptic reactions up to the transformations of information by neural clusters.
- Often, the lower level is more complex.
- A pancreatic islet cell is enormously complicated. Yet modeling what a pancreas does (in terms of regulating levels of insulin and digestive enzymes) is considerably less complex than a detailed model of a single islet cell.

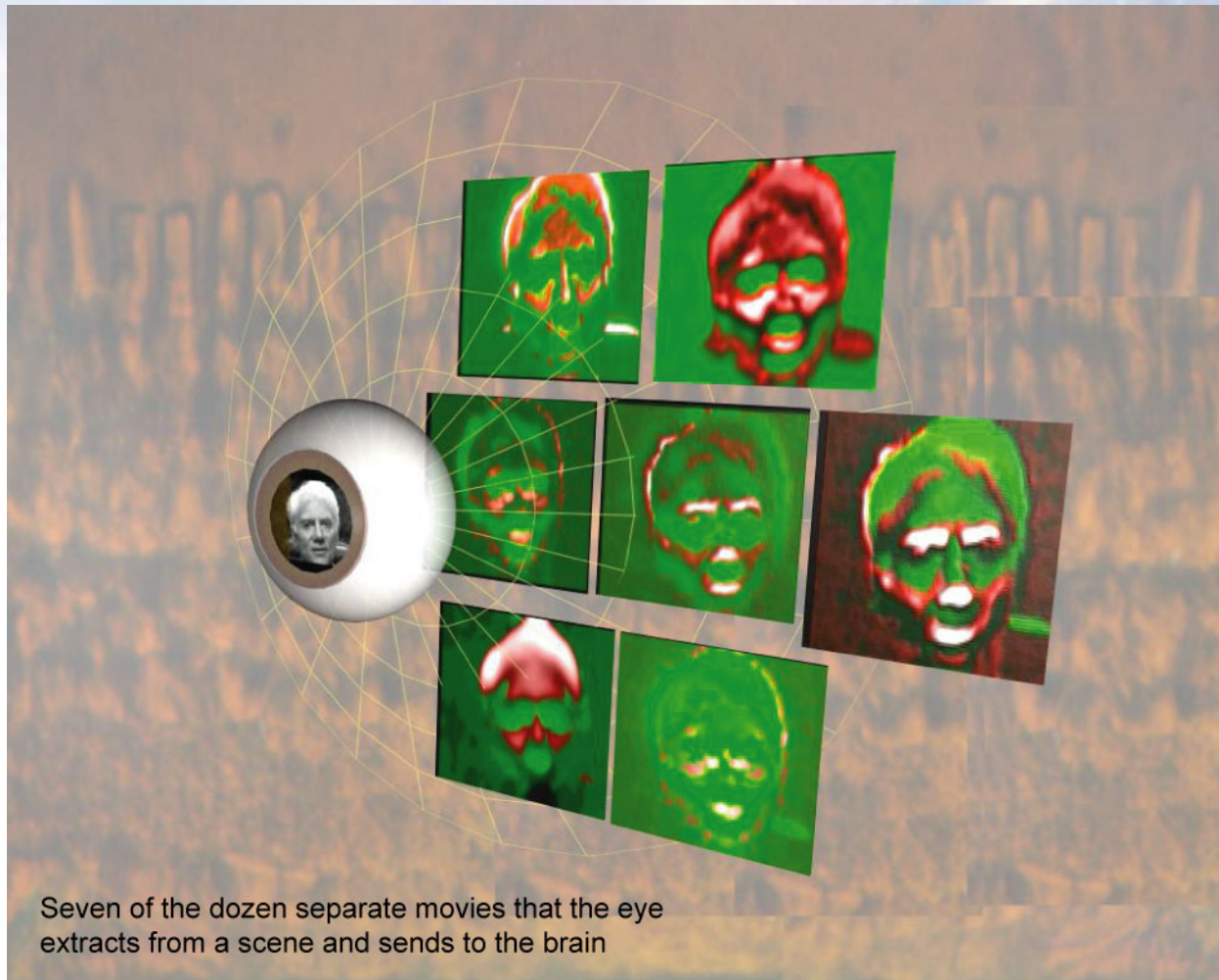

Seven of the dozen separate movies that the eye extracts from a scene and sends to the brain

# The Cerebellum

- The basic wiring method of the cerebellum is repeated billions of times.
- It is clear that the genome does not provide specific information about each repetition of this cerebellar structure
  - but rather specifies certain constraints as to how this structure is repeated
    - just as the genome does not specify the exact location of cells in other organs, such the location of each pancreatic Islet cell in the pancreas

# The Cerebellum

- Gathering data from multiple studies, Javier F. Medina, Michael D. Mauk, and their colleagues at the University of Texas Medical School devised a detailed bottom-up simulation of the cerebellum.
- Their simulation includes over 10,000 simulated neurons and 300,000 synapses, and includes all of the principal types of cerebellum cells.

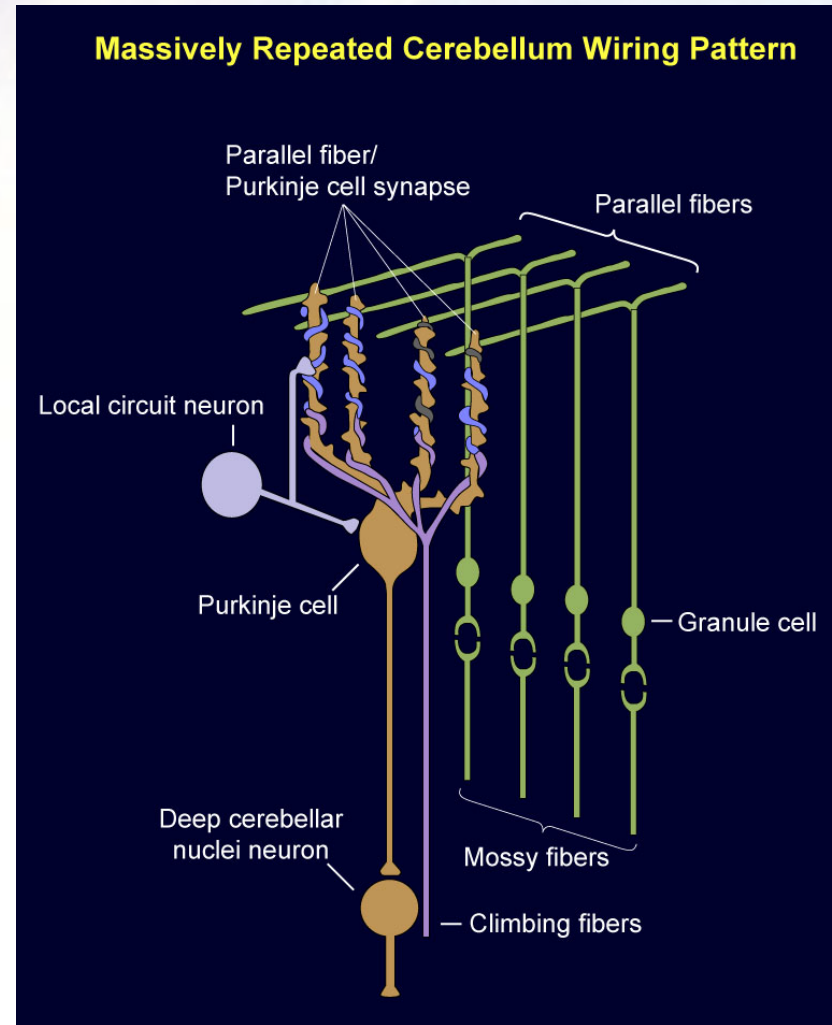

# The Law of Accelerating Returns is driving economic growth

- The portion of a product or service's value comprised of information is asymptoting to 100%
- The cost of information at every level incurs deflation at ~ 50% per year
- This is a powerful deflationary force
  - Completely different from the deflation in the 1929 Depression (collapse of consumer confidence & money supply)

United States  
**Real GDP**

Logarithmic Plot



United States  
**Per Capita GDP**

Logarithmic Plot

100,000

Chained (2000) Dollars

1,000

'30

'40

'50

'60

'70

'80

'90

2000

'07 '10

Year

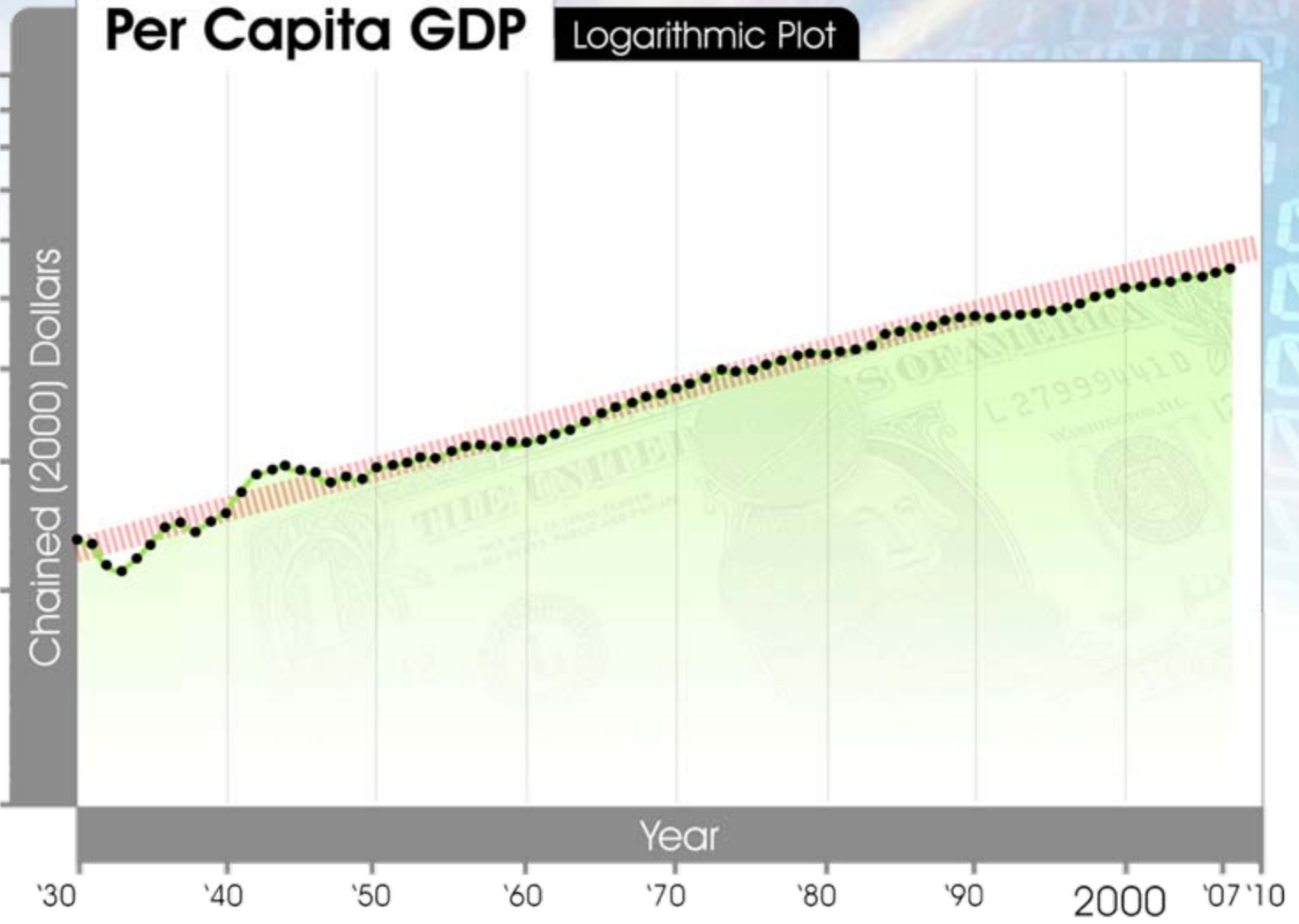

Manufacturing

# Labor Productivity

Constant dollars, indexed to the year 2000

Logarithmic Plot

1,000

Output per Hour

100

10

Year

'45

'50

'55

'60

'65

'70

'75

'80

'85

'90

'95

2000

'05

'10

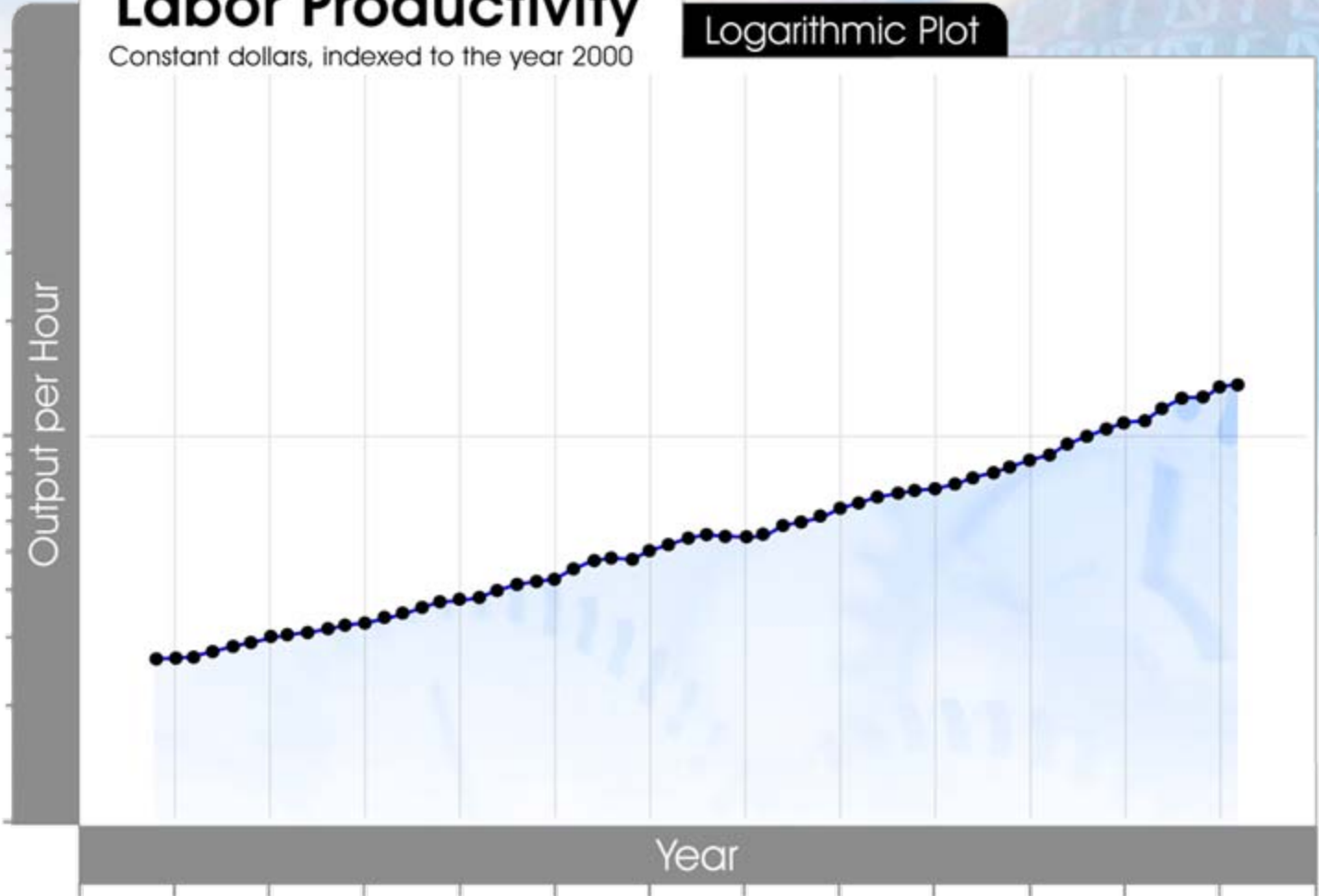

## E-commerce Revenues in The United States

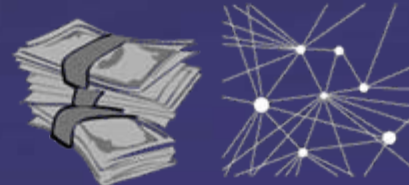

Logarithmic Plot

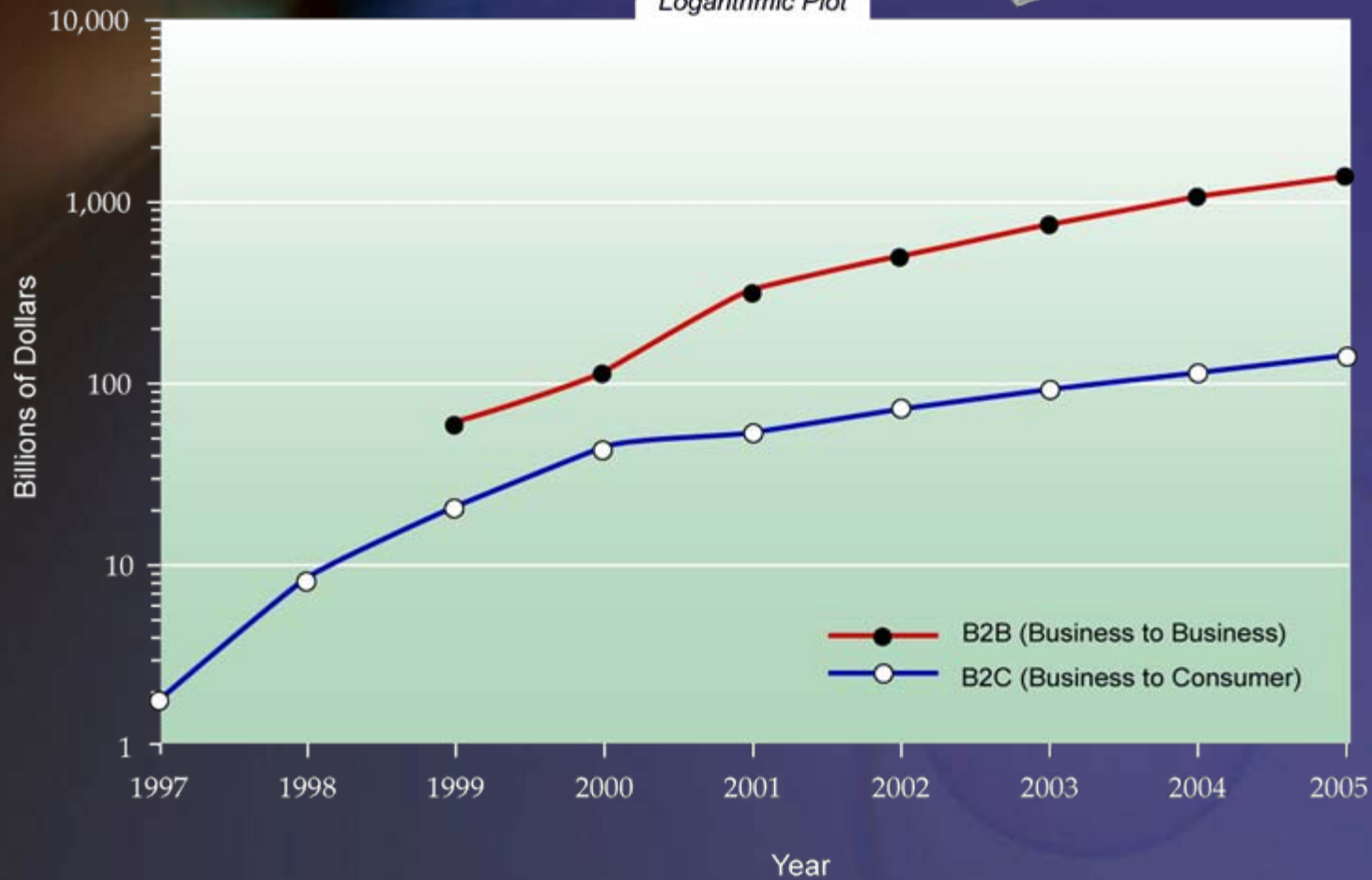

# IT's Share of the Economy



Logarithmic Plot



# U.S. Patent Applications

Logarithmic Plot

1,000,000

100,000

10,000

1,000

100

10

1

Patent Applications

Year

1840

1860

1880

1900

1920

1940

1960

1980

2000

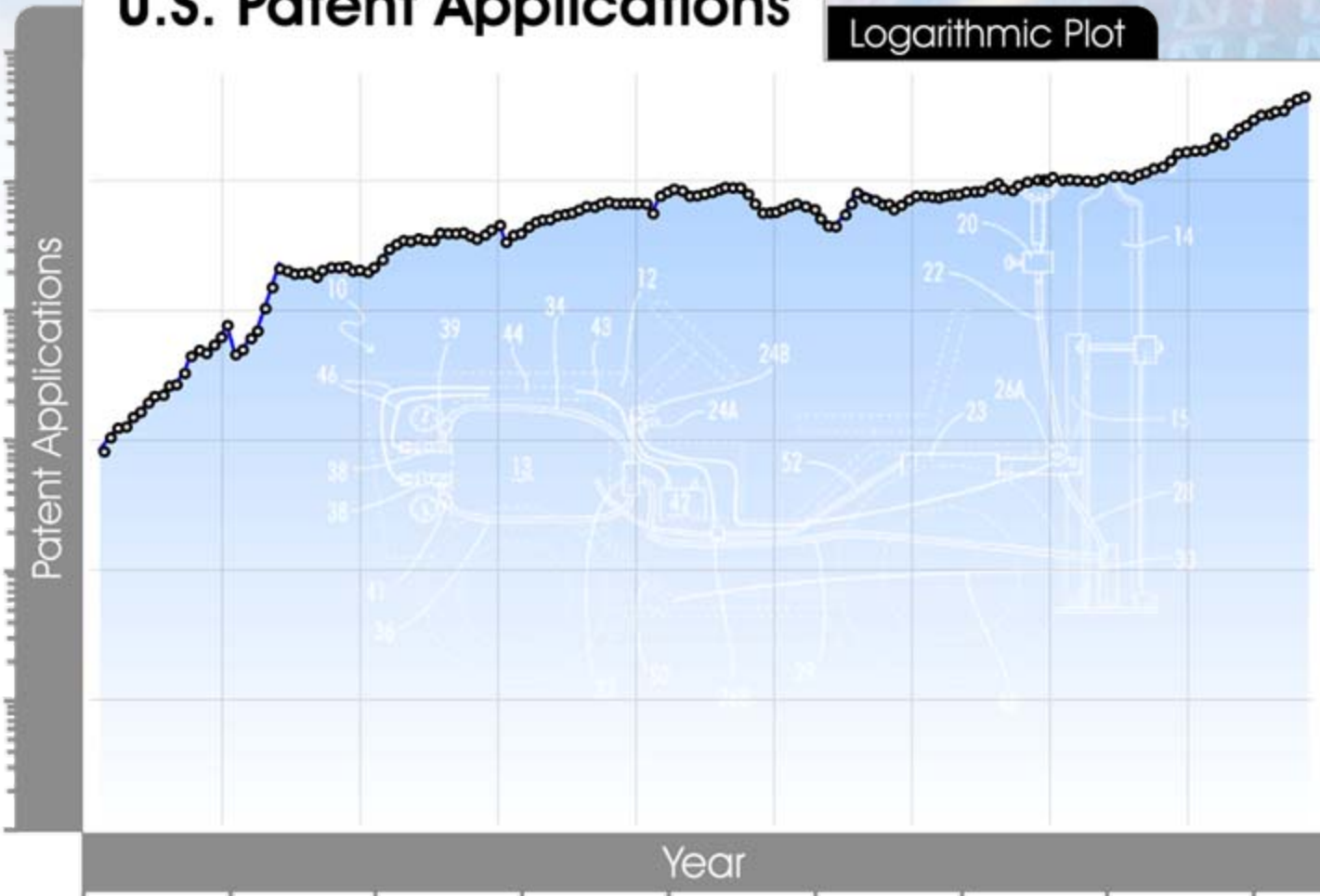

(Constant 2006 Dollars)

## U.S. Education Expenditure

Linear Plot

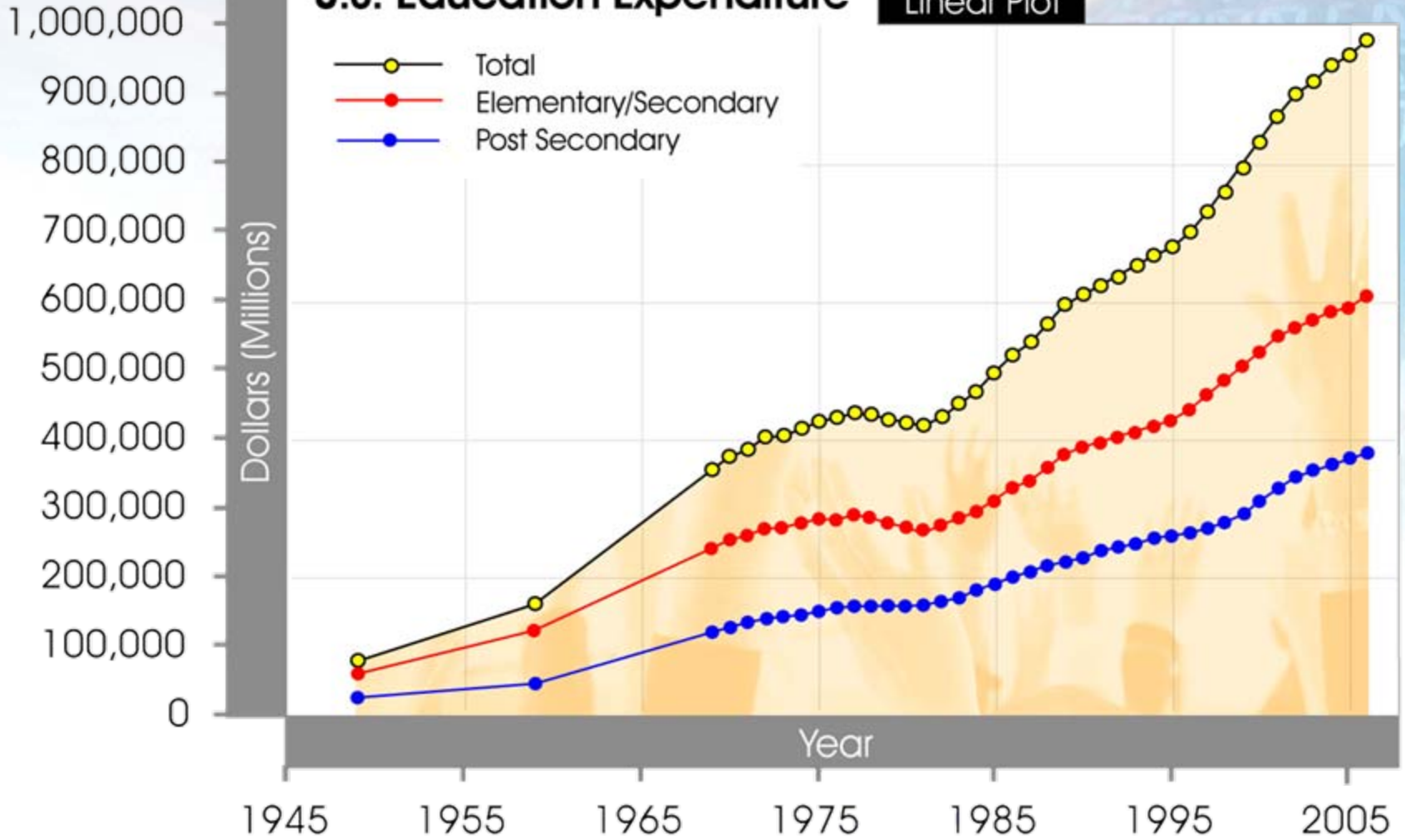

(Constant 2006-2007 Dollars)

# U.S. Education Expenditure Per Capita

Linear Plot

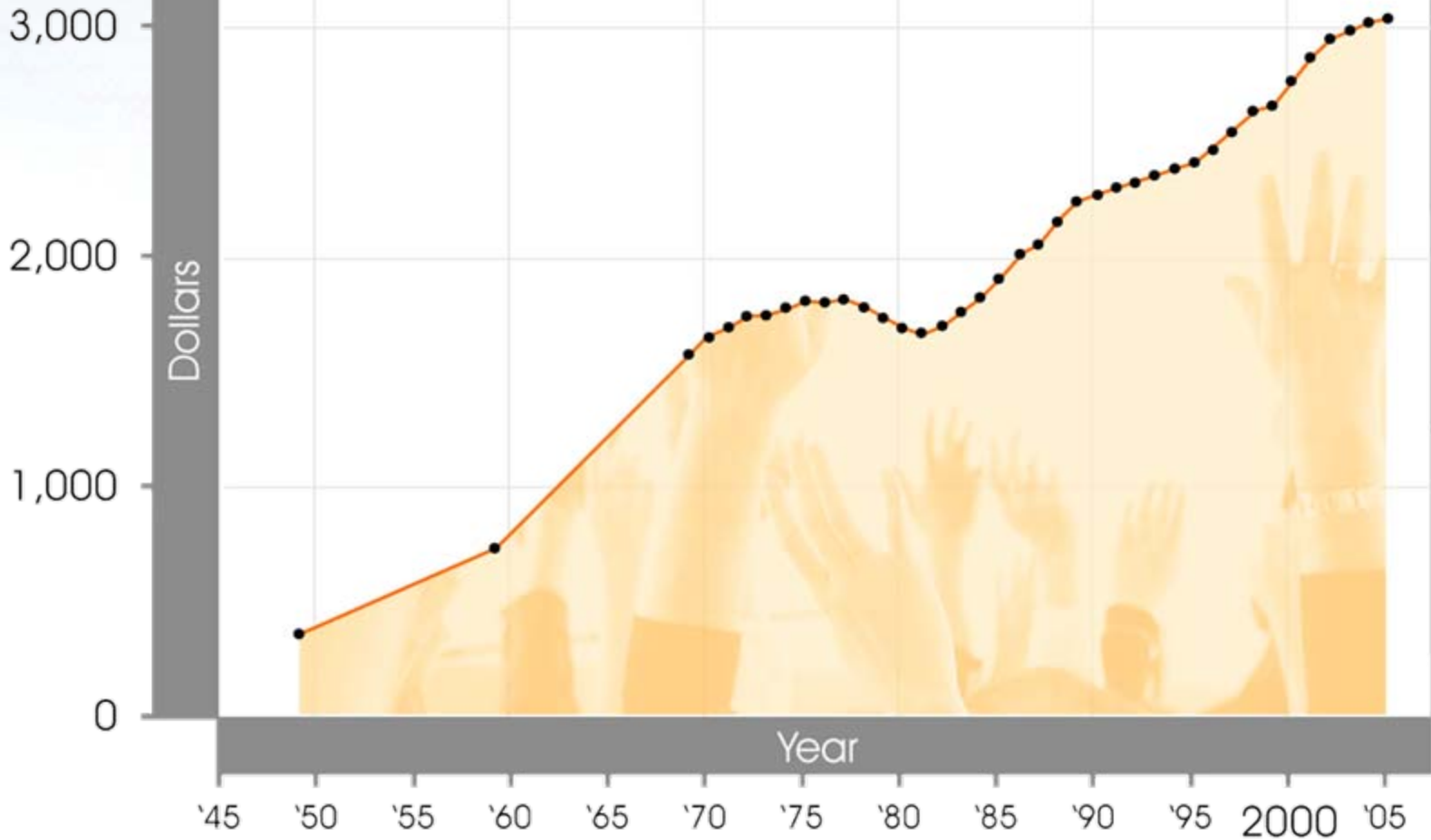

# Solar Energy

- Emerging nanotechnology will accelerate progress of cost of solar panels and storage - fuel cells
- Tipping point (cost per watt less than oil and coal) expected within 5 years
- Progress on thermo-solar
- Doubling time for watts from solar < 2 years
  - We are less than 10 doublings from meeting 100% of the world's energy needs

World Annual (1975- 2007)

# Photovoltaic Production

Linear Plot

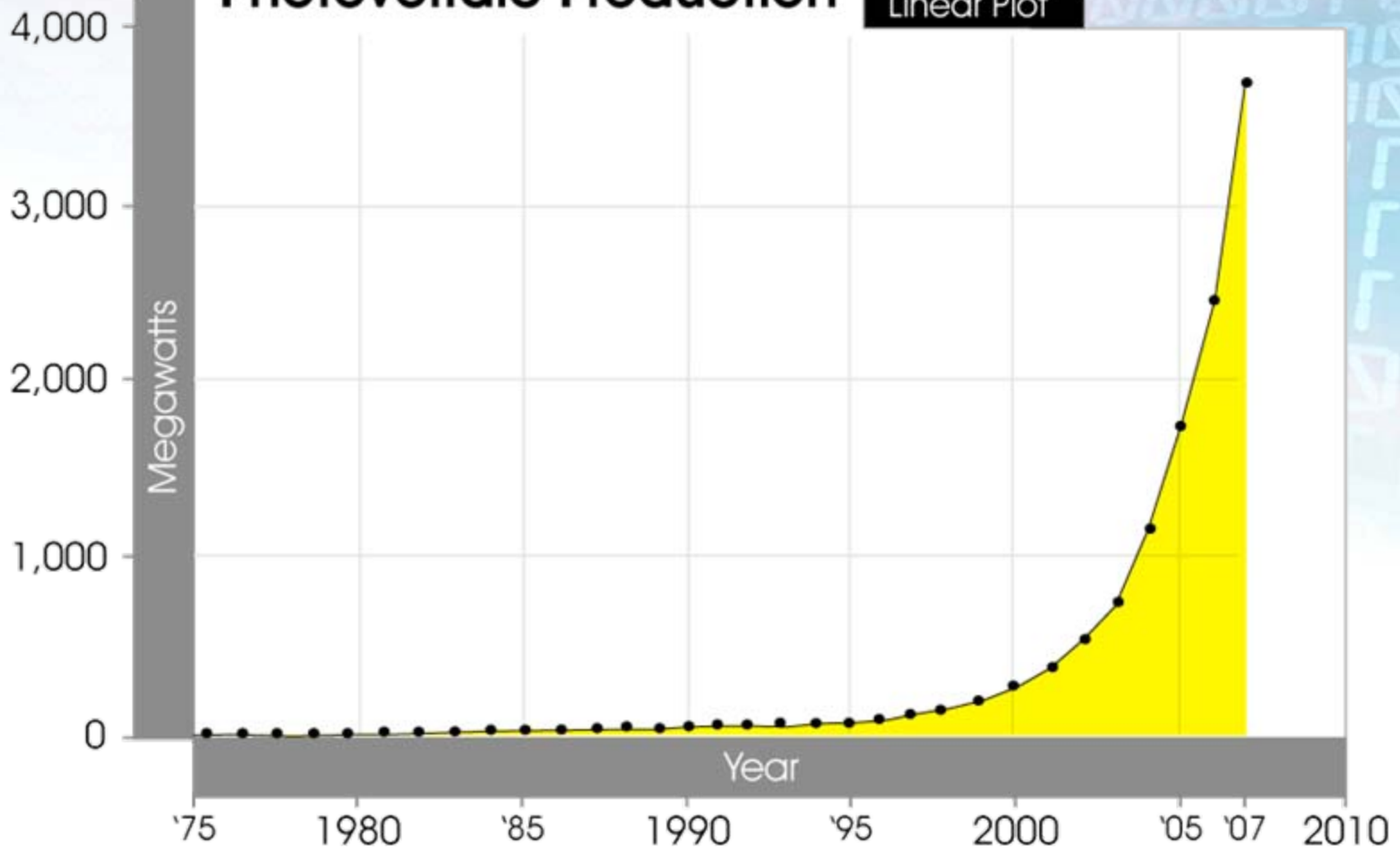

World Annual (1975-2007)

# Photovoltaic Production

Logarithmic Plot

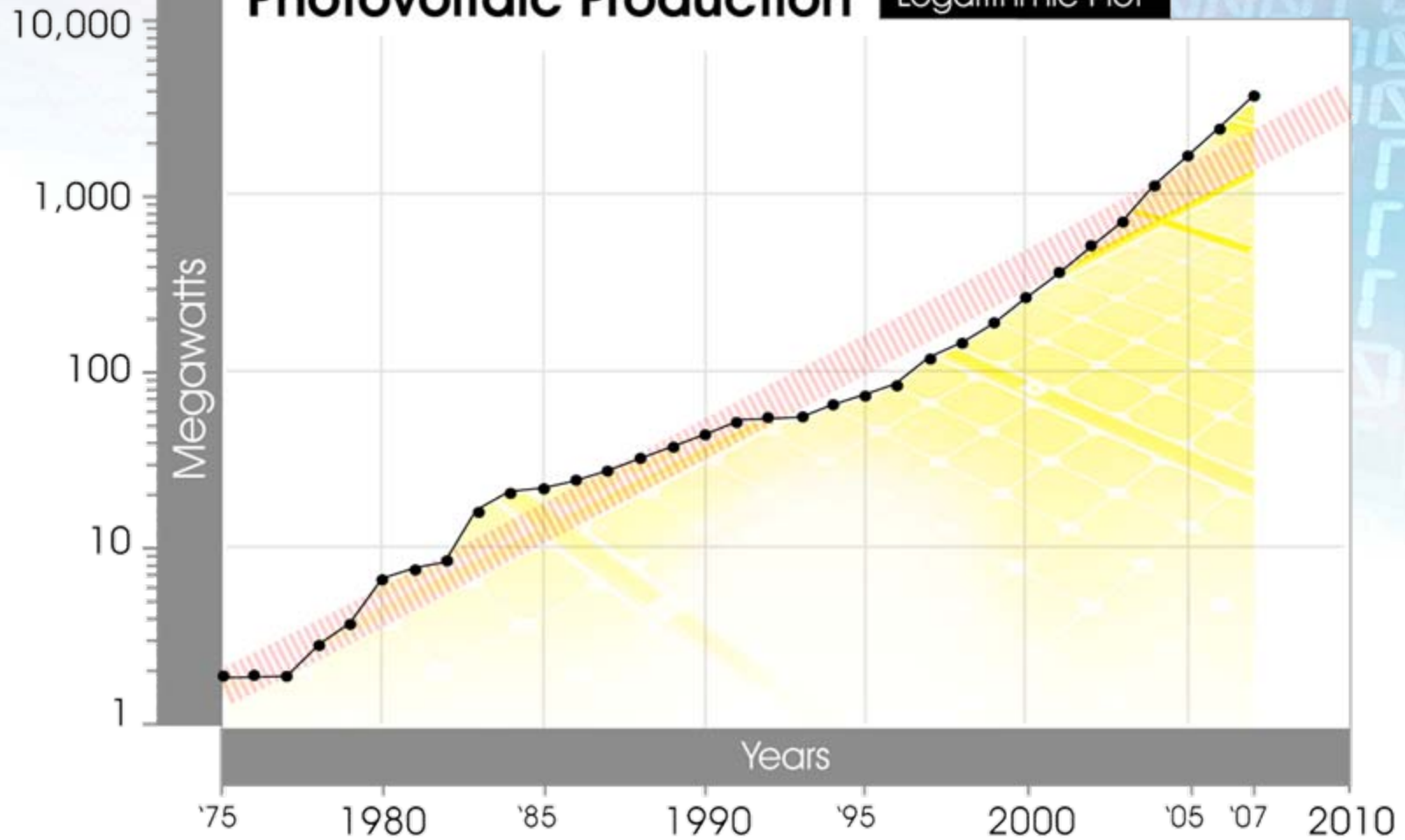

World Cumulative (1975-2007)  
**Photovoltaic Production**

Linear Plot

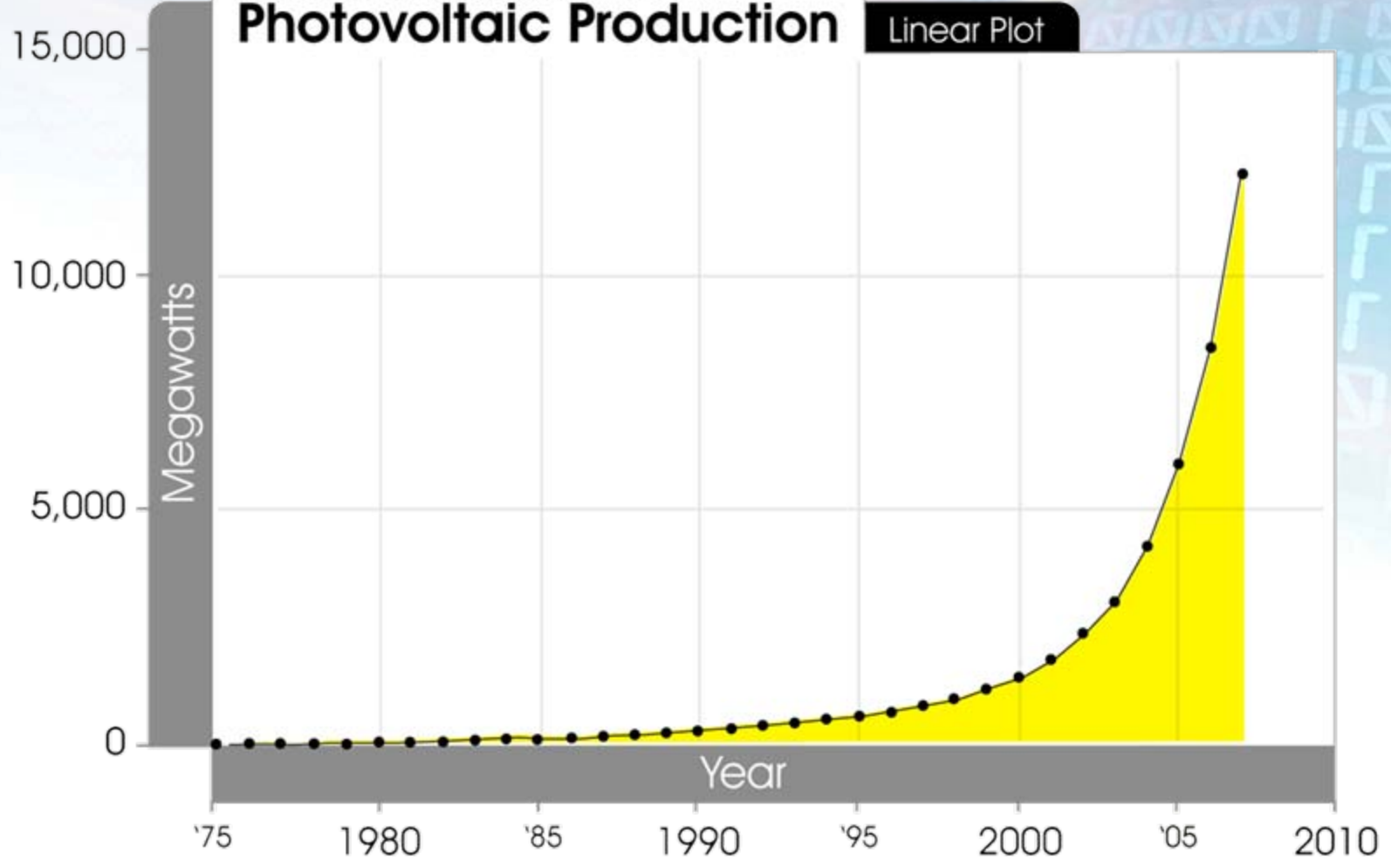

World Cumulative (1975-2007)  
**Photovoltaic Production**

Logarithmic Plot

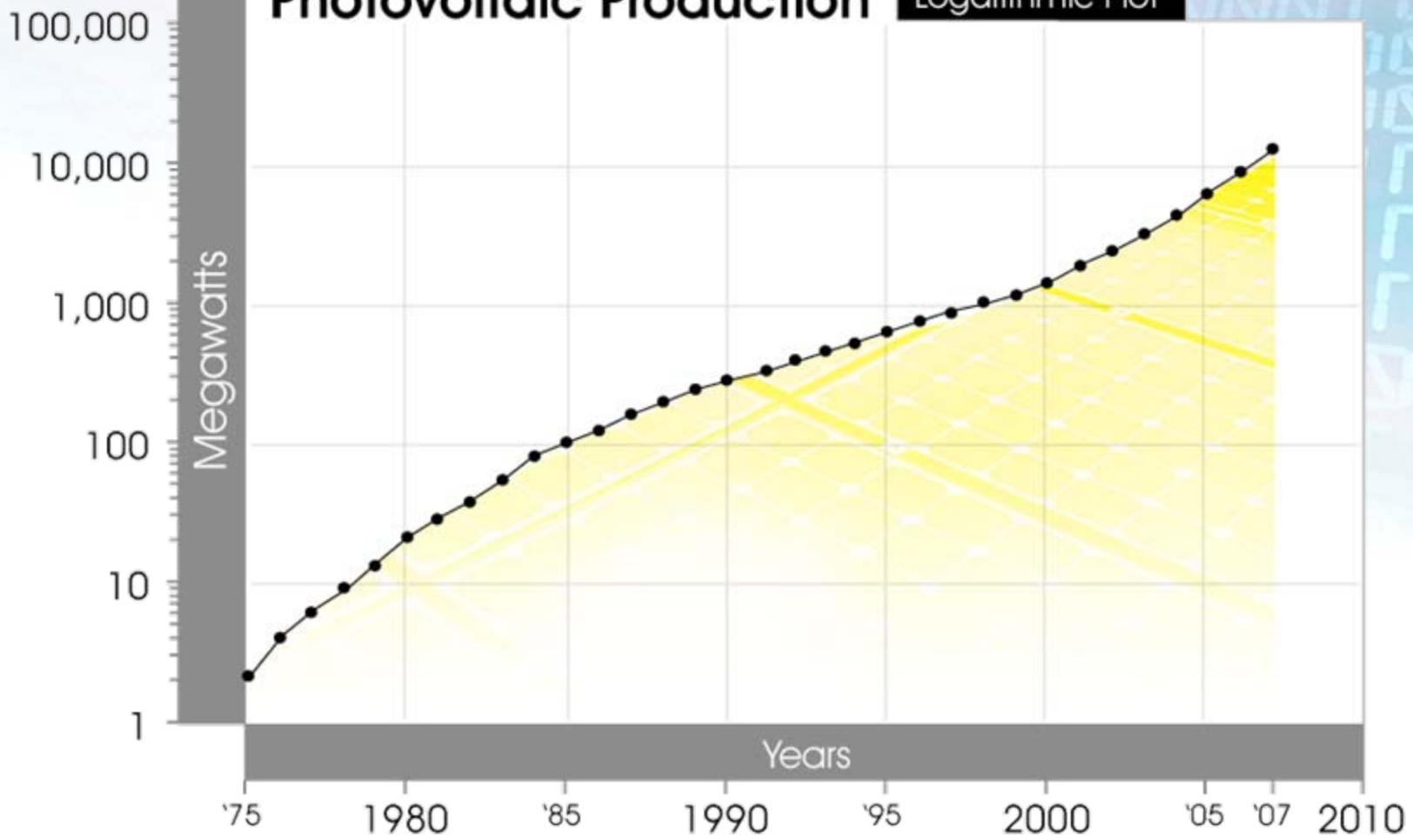

Select Countries & Europe Annual (1995-2006)

# Photovoltaic Production

Linear Plot

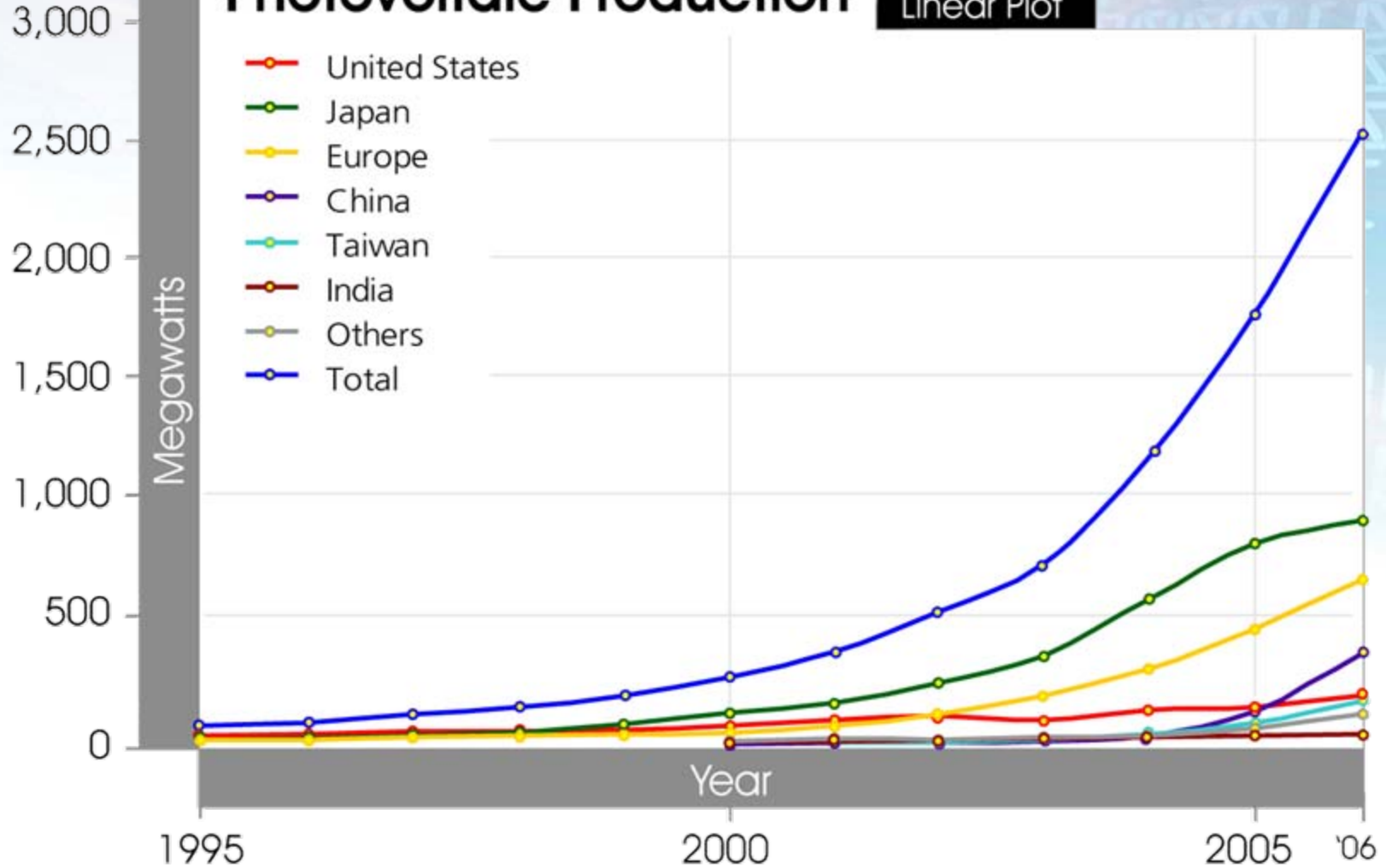

Select Countries & Regions (2000-2007)

## Annual Photovoltaic Installations

Linear Plot

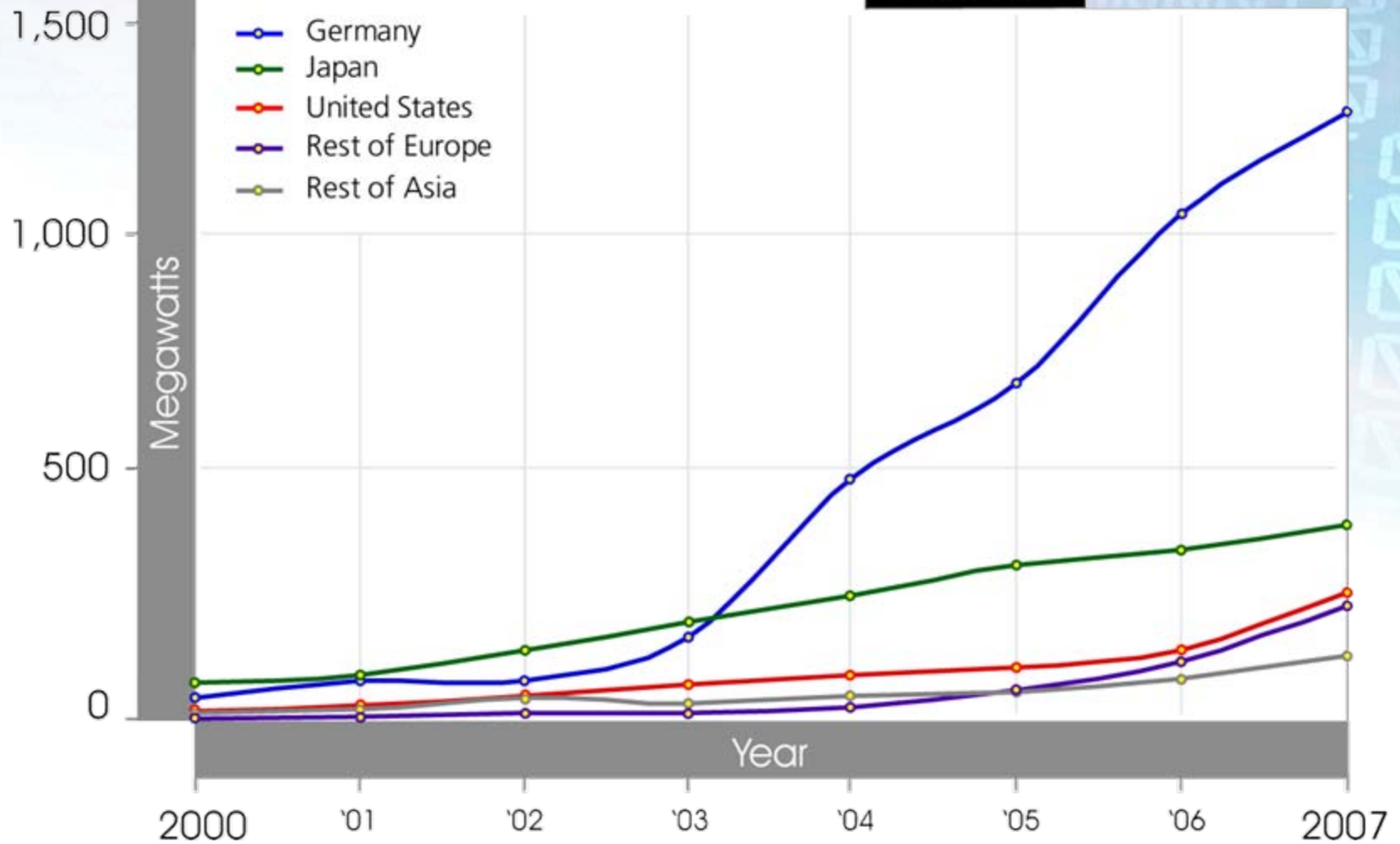

World Average (1975-2006)

# Photovoltaic Module Cost Per Watt

Linear Plot

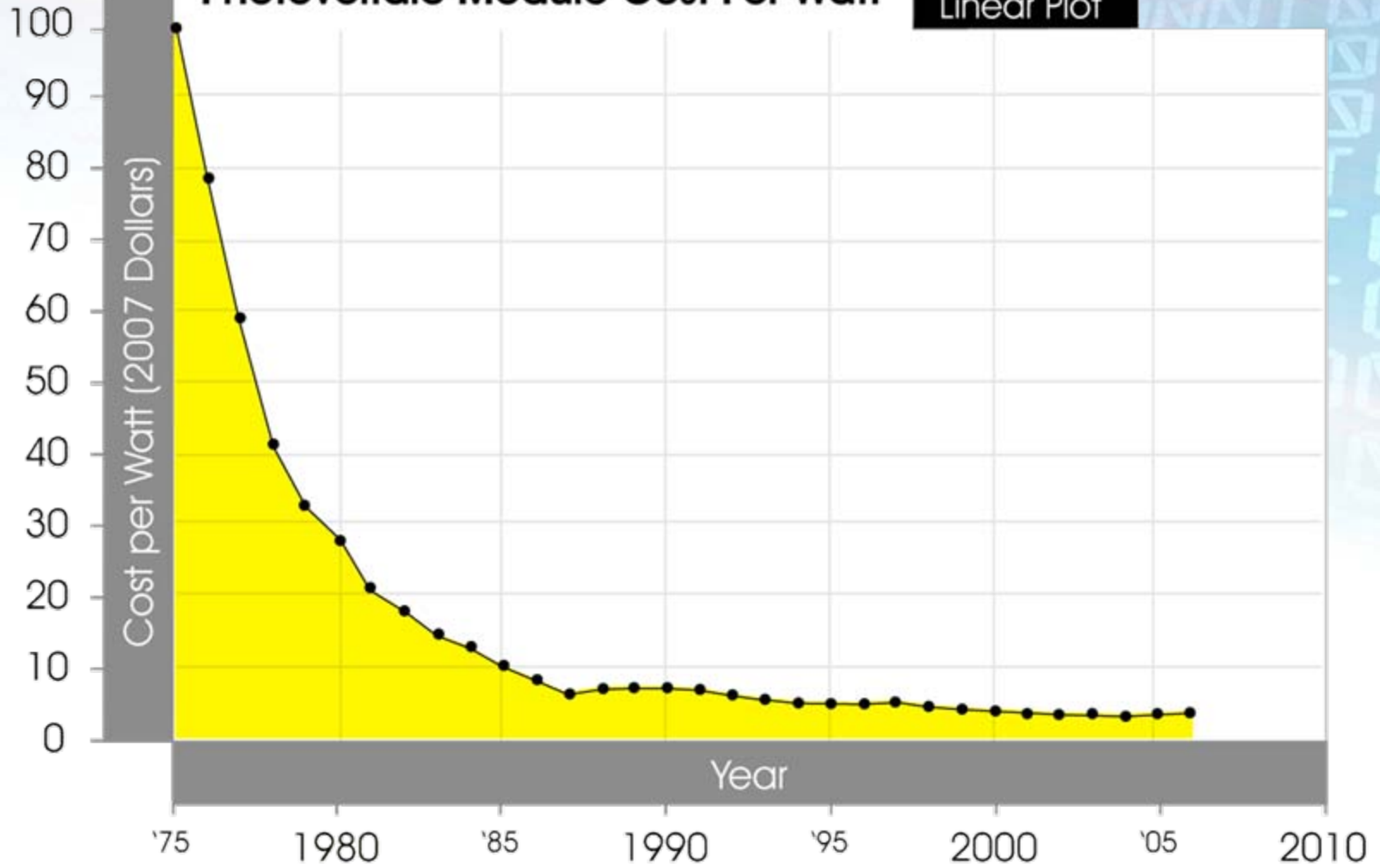

1975-2004 (2007 US Dollars)

# Watts per \$1000

Linear Plot

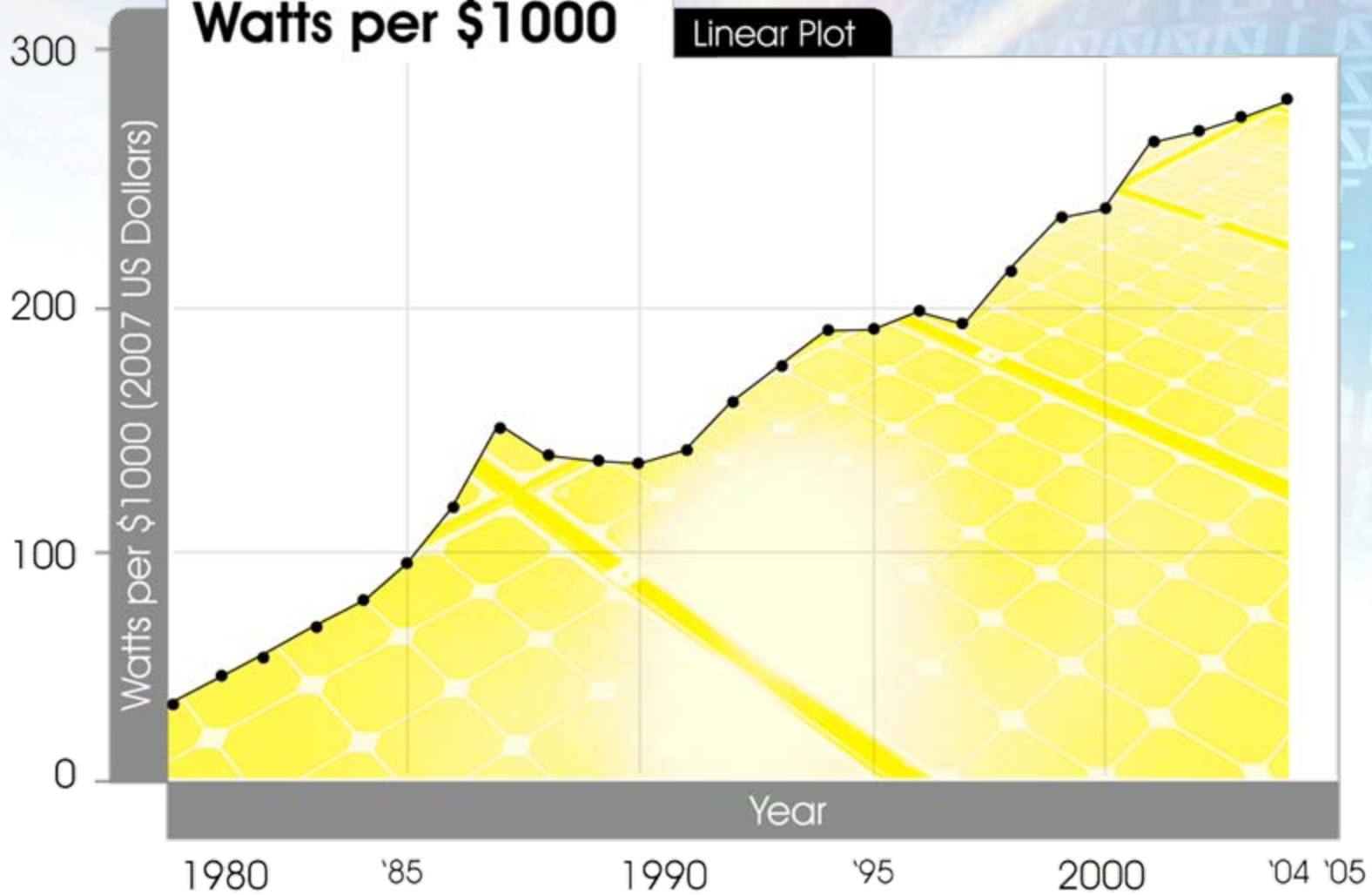

# Gut Erlasee Solar Park



Arnstein, Germany

# First All Solar City



## Masdar City

- 50,000 people
- People will move in by 2010
- Carbon Neutral
- In Abu Dhabi

# Contemporary examples of self-organizing systems

- The bulk of human intelligence is based on **pattern recognition**: the quintessential example of self-organization

# Contemporary examples of self-organizing systems

- Machines are rapidly improving in pattern recognition
- Progress will be accelerated now that we have the tools to reverse engineer the brain
- Human pattern recognition is limited to certain types of patterns (faces, speech sounds, etc.)
- Machines can apply pattern recognition to any type of pattern
- Humans are limited to a couple dozen variables, machines can consider thousands simultaneously





# 2010: Computers disappear

- Images written directly to our retinas
- Ubiquitous high bandwidth connection to the Internet at all times
- Electronics so tiny it's embedded in the environment, our clothing, our eyeglasses
- Full immersion visual-auditory virtual reality
- Augmented real reality
- Interaction with virtual personalities as a primary interface
- Effective language technologies



## 2029: An intimate merger

- \$1,000 of computation = 1,000 times the human brain
- Reverse engineering of the human brain completed
- Computers pass the Turing test
- Nonbiological intelligence combines
  - the subtlety and pattern recognition strength of human intelligence, with
  - the speed, memory, and knowledge sharing of machine intelligence
- Nonbiological intelligence will continue to grow exponentially whereas biological intelligence is effectively fixed

# Nanobots provide...

- Neural implants that are:
  - Noninvasive, surgery-free
  - Distributed to millions or billions of points in the brain
- Full-immersion virtual reality incorporating all of the senses
  - You can be someone else
  - “Experience Beamers”
- Expansion of human intelligence
  - Multiply our 100 trillion connections many fold
  - Intimate connection to diverse forms of nonbiological intelligence

## Average Life Expectancy (Years)

Cro Magnon	18
Ancient Egypt	25
1400 Europe	30
1800 Europe & U.S.	37
1900 U.S.	48
2002 U.S.	78

# Implications of the Law of Accelerating Returns on Army Science and Technology Priorities

ast improvements in:

- Reduce development cycle time for new weapons systems
  - Increase use of simulation
- Develop the “remote-robotic-robust-size-reduced-virtual reality” paradigm

# Move personnel away from combat to the extent possible:

- Remotely guided systems
- Increase level of autonomous control
- Miniaturized systems
- Robotic systems
- Self-organizing, secure communications

# Virtual Reality Systems

- Put human controllers virtually “inside” combat systems (e.g., armed predator)
- Soldiers inside weapons (e.g., tanks) also need virtual reality environments
- For training

## Miniaturization: top-down

- Start with concept of conventional tanks, planes
- Take human out, eliminate human support
- Then make them smaller to be more maneuverable
- Perform higher-risk missions

# Miniaturization: bottom-up

- Smart Dust
  - Power from movement, wind, thermal currents, nano fuel-cells
  - Go beyond today's passive smart dust prototypes
- Insect and golf ball size devices
- Smart bullets
- Harness swarm intelligence

# Capabilities of swarms of tiny devices

- Reconnaissance on movement of people and machinery
- Locate specific persons (thermal and electromagnetic fields)
- Ultimately combat missions

# Highly secure and self-organizing command and control

- Information flows in from many sources:
  - Every person at every level of command
  - Every device
  - Software agents processing information

# Information needs to be presented:

- To each person:
  - Effective display environments
  - Highlighting of the most important information
  - Immersive environments
  - Take into account mission and capabilities of each combatant and commander
- To each device

# Communications must be self-organizing

- World wide mesh
- Each node can both send and receive its own and other messages
- No centralized points of control that would be vulnerable
- Highly distributed
- Scalable
- Secure

# Bioterrorism

- The primary existential threat is from bioengineered biological viral agents.
- We need to greatly increase the priority of developing broad spectrum anti-viral technologies.
- Idea: Rapid response through RNA interference.

## Other Key Areas

- Simulation for development testing, and training
- Lightweight, intelligent armor (nanocoatings)
- Automated diagnosis and treatment built into the armor
- Extending human capability
  - Robotic extension of human motion
  - Perceptual and cognitive
- Space-based weapons

# Cyberwarfare

- Security of our own self-organizing communications
- Ability to infiltrate, disrupt, confuse and/or destroy enemy communications
- Encryption and decryption

## Bachelors Degrees in Engineering, US (citizens and permanent residents) and China

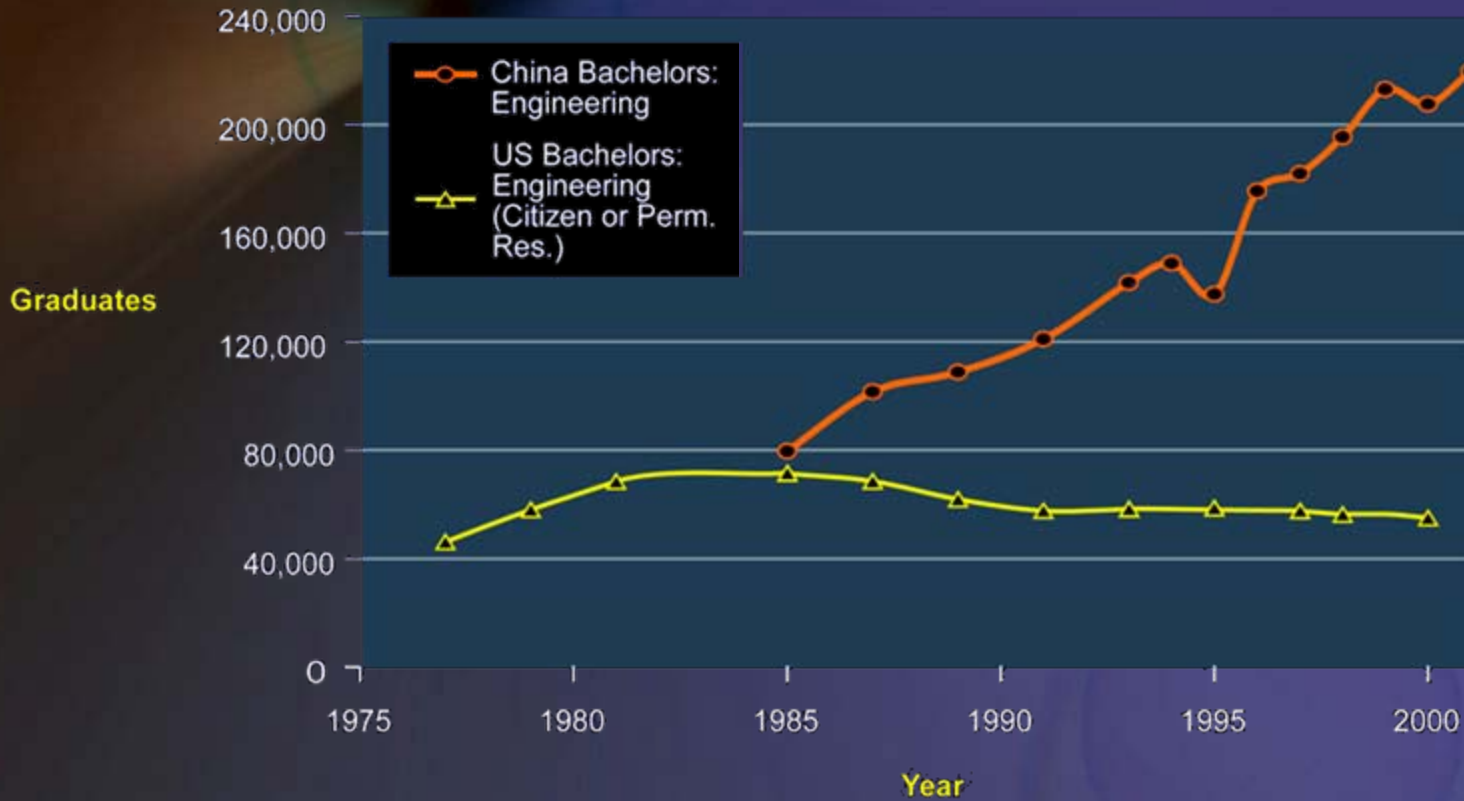

Data from: NSF and NBS

## Bachelors Degrees in Engineering, US (citizens and permanent residents) and Asia (China, Japan, Korea)

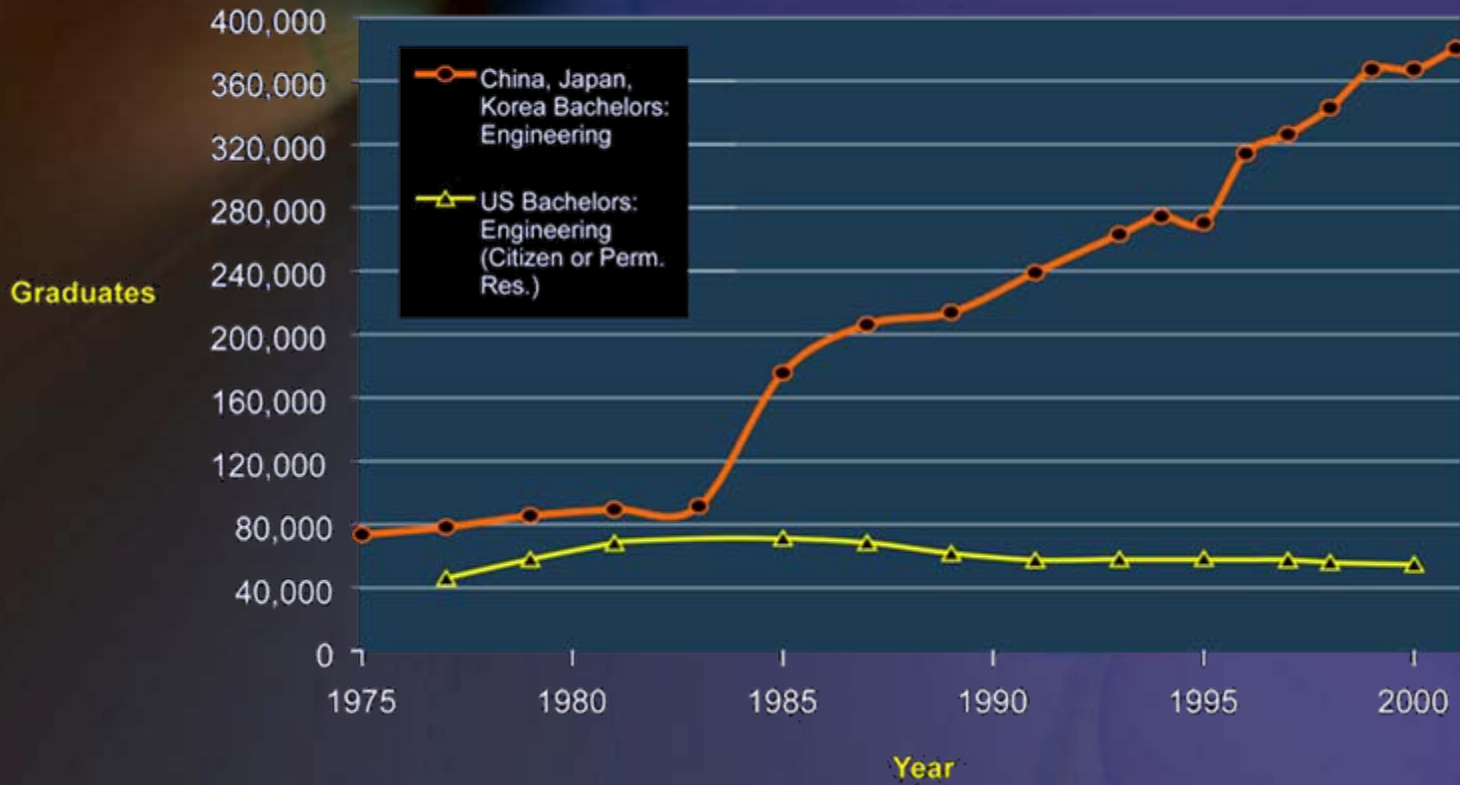

Linear Plot

Data from: NSF and NBS

## Bachelors Degrees in Natural Sciences, Comp.Sci., and Engineering, US (citizens and permanent residents) and Asia (China, Japan, Korea)

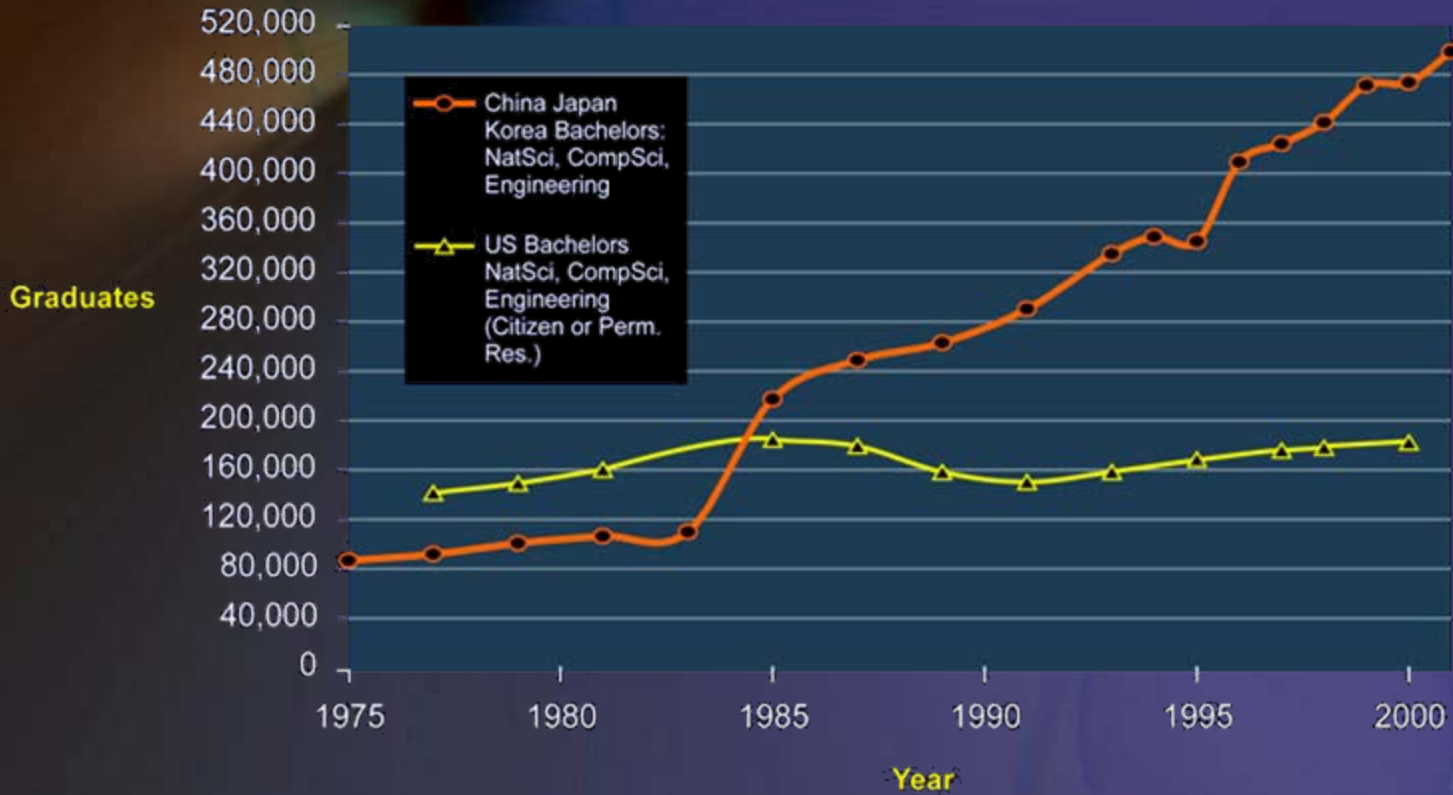

Data from: NSF and NBS

## Doctoral Degrees in Engineering, US (citizens) and China

Graduates

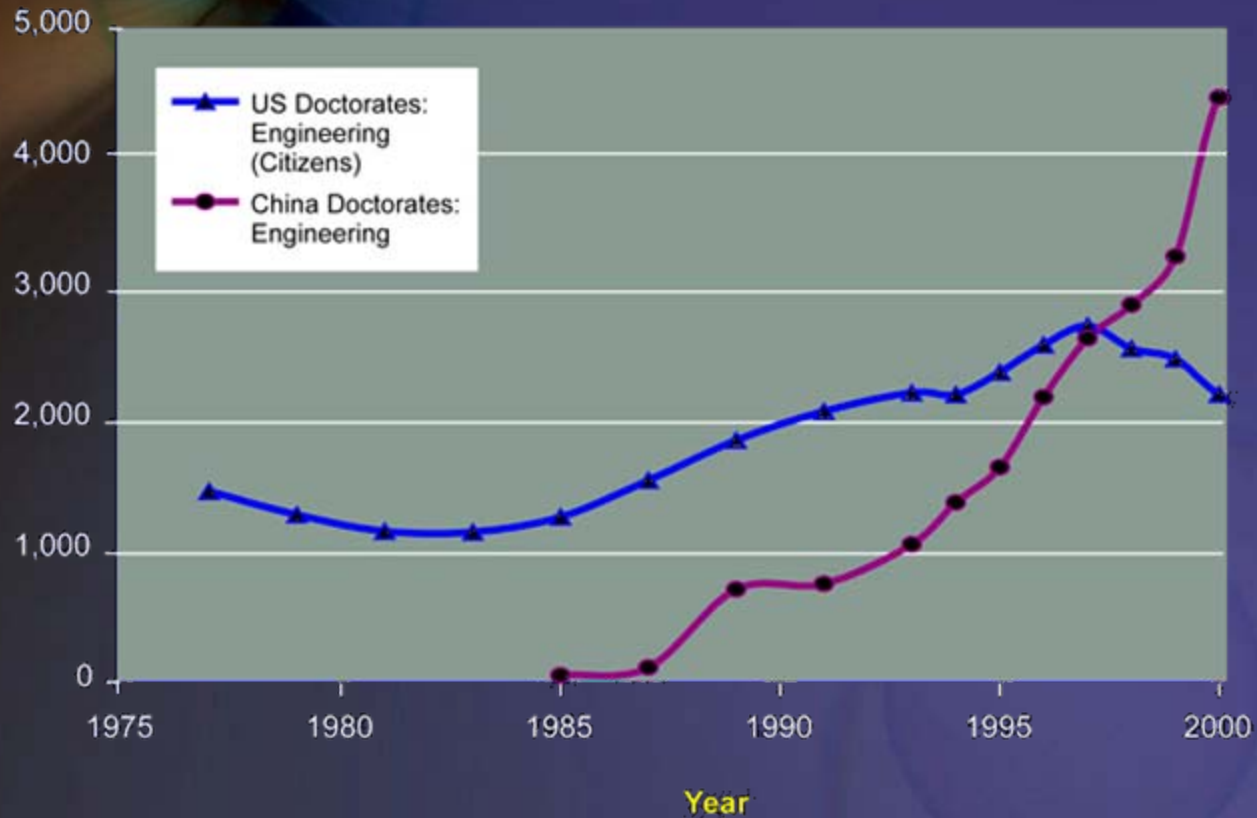

Data from: NSF and NBS

## Doctoral Degrees in Engineering, US (citizens) and Asia

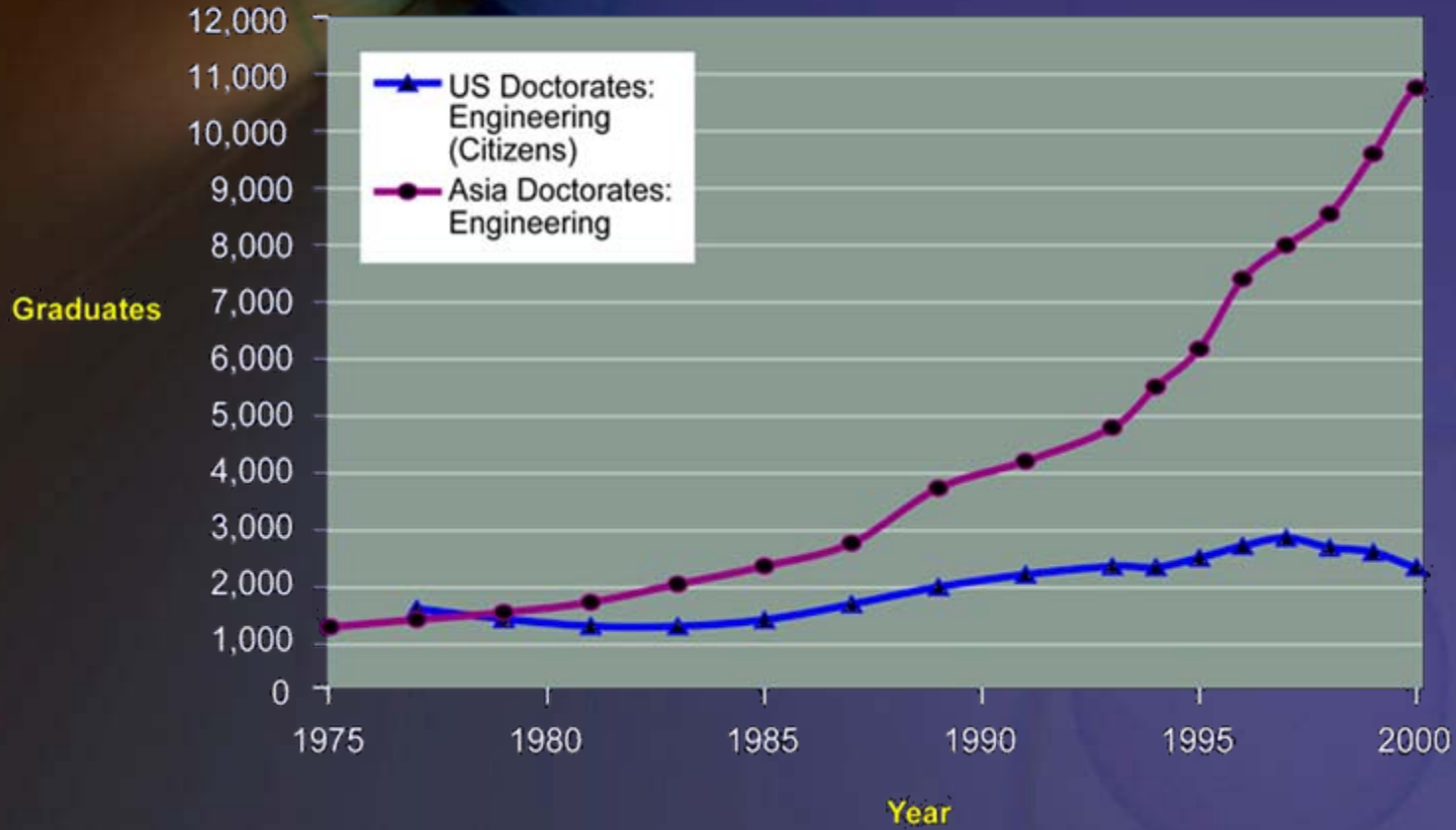

Linear Plot

Data from: NSF and NBS

## Doctoral Degrees in Natural Science, Comp.Sci., and Engineering, US (citizens) and China, Japan and Korea

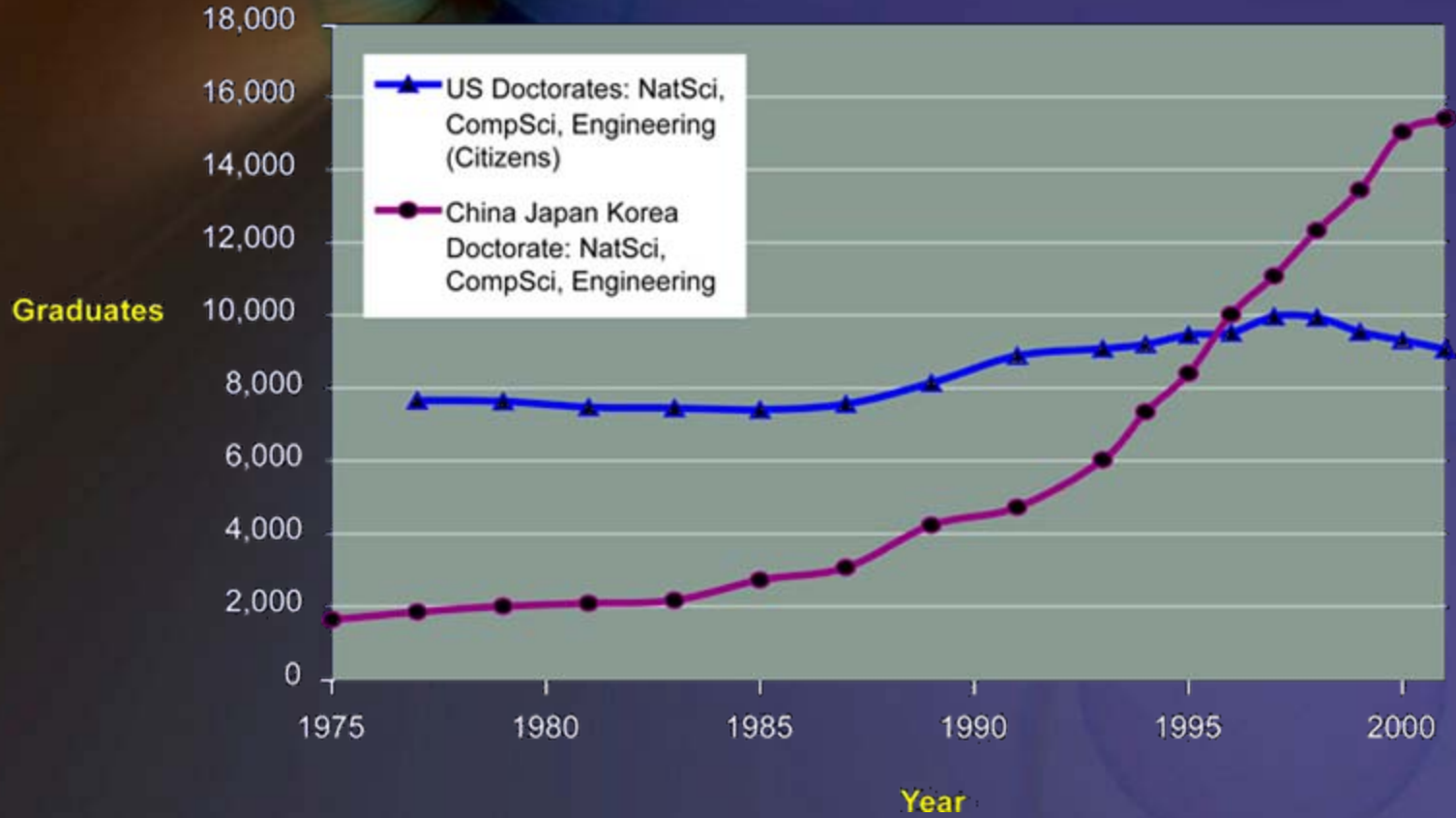

Linear Plot

Data from: NSF and NBS

## Doctoral Degrees in Natural Science, Comp.Sci., and Engineering, US (citizens) and Asia

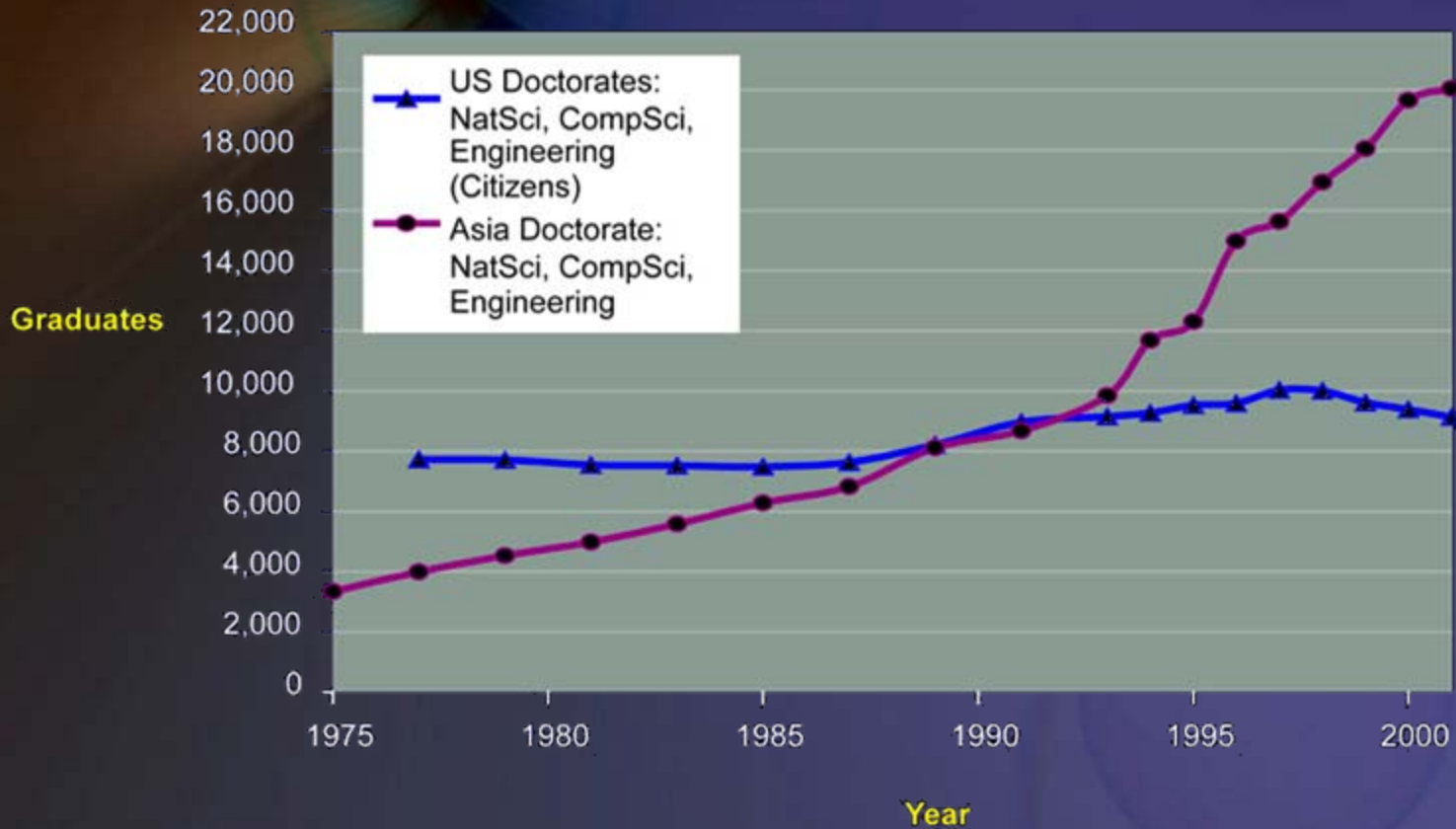

Linear Plot

Data from: NSF and NBS

# US War Deaths

Logarithmic Plot

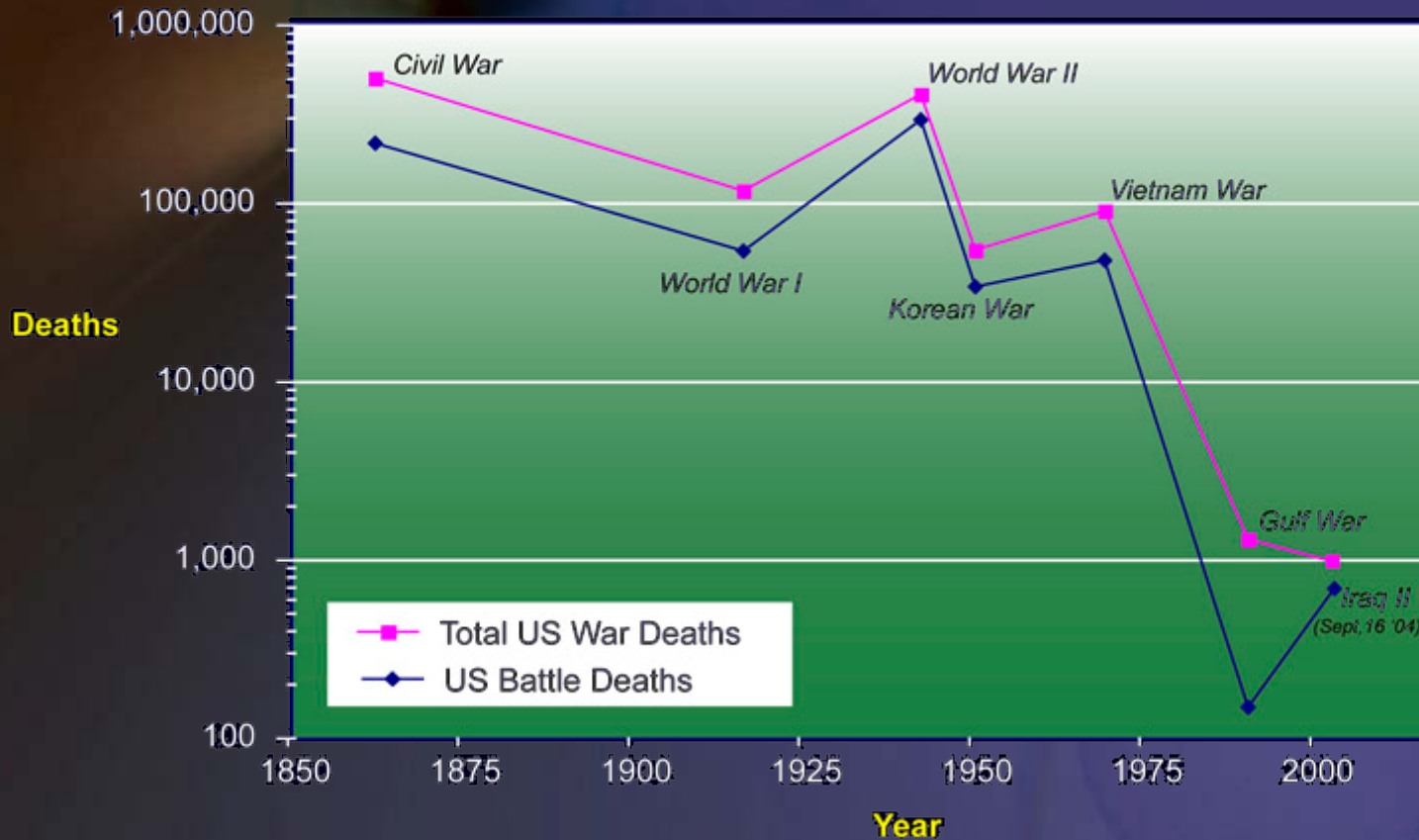

Source: Dataquest/Intel

# Reference URLs:

**Graphs available at:**

[www.KurzweilAI.net/pps/26ASC/](http://www.KurzweilAI.net/pps/26ASC/)

**Home of the Big Thinkers:**

[www.KurzweilAI.net](http://www.KurzweilAI.net)

# The Criticism...

- from Incredulity

# The Criticism from Malthus

- “Exponential trends can’t go on forever” (rabbits in Australia...)
  - Law of accelerating returns applies to information technologies
  - There are limits
    - But they’re not very limiting
  - One paradigm leads to another....but
    - Need to verify the viability of a new paradigm
    - Molecular computing is already working
      - Nanotube system with self-organizing features due to hit the market next year
      - Molecular computing not even needed: strong...cheap... AI feasible with conventional chips according to ITRS
      - Exotic technologies not needed

# The Criticism from software

- “Software / AI is stuck in the mud”
- Computers still can't do.....(fill in the blank)
  - The history of AI is the opposite of human maturation
    - CMU's GPS in the 1950's solved hard *adult* math problems (that stumped Russell & Whitehead)
    - But computers could not match a young child in basic pattern recognition
      - This is the heart of human intelligence
    - Tell the difference between a dog and a cat?

# The Criticism from software cont.

- Hundreds of AI applications deeply embedded in our economic infrastructure
  - CAD, just in time, robotic assembly, billions of \$ of daily financial transactions, automated ECG, blood cell image analysis, email routing, cell connections, landing airplanes, autonomous weapons.....
  - If all the AI programs stopped....
  - These were all research projects when we had the last summit in 1999

# The Criticism from software cont.

- “AI is the study of how to make computers do things at which, at the moment, people are better.” - *Elaine Rich*
- Unsolved Problems have a mystery
  - Intelligence also has a mystery about it...
  - As soon we know how to solve a problem, we no longer consider it “intelligence”
- “At first I thought that you had done something clever, but I see that there was nothing in it, after all” - said to Sherlock Holmes
  - “I begin to think that I make a mistake in explaining.” - Sherlock Holmes

# The Criticism from software cont.

- Software complexity and performance is improving
  - Especially in the key area of pattern recognition
    - Only recently that brain reverse-engineering has been helpful
- Take chess, for example
  - The saga of Deep Fritz
  - With only 1% of the computes of Deep Blue, it was equal in performance
    - Equal in computes to Deep Thought yet it rated 400 points higher on chess rating (a log scale)
    - *How was this possible*: Smarter pattern recognition software applied to terminal leaf pruning in minimax algorithm
- Or autonomous vehicles....and weapons

# The Criticism from software cont.

## ■ Genetic Algorithms

- Good laboratory for studying evolution
- More intelligence from less
- GA's have become more complex, more capable
  - Evolving the means of evolving
    - Not just evolving the content of the genetic code but adding new genes
    - Reassigning the interpretation of genes
    - Using codes to control gene expression
  - Means to overcome over fitting to spurious data
  - Larger genomes
- But GA's are not a silver bullet
  - One self-organizing technique of many

# The Criticism from software cont.

- Military technology: steady increase of sophisticated autonomous weapons
- Software productivity exponentially increasing
- Algorithms getting more sophisticated (e.g., search, autocorrelation, compression, wavelets)
- Measures of software complexity (log scale) increasing steadily
- Combined impact of:
  - Increasingly complex pattern recognition methods
    - Starting to be influenced by biologically inspired paradigms
  - Vast data mining not feasible just 7 years ago

# The criticism from reliability

- “Software is too brittle, too crash prone”  
(Jaron Lanier, Thomas Ray)
  - We CAN (and do) create reliable software
    - Intensive care, 911, landing airplanes
      - No airplane has crashed due to software crashes despite software being responsible for most landings
  - Decentralized self-organizing systems are inherently stable
    - The downtime for the Internet over the last decade is zero seconds

# The criticism from the complexity of brain processing

- The complexity of all the nonlinearities (ion channels, etc) in the brain is too complex for our technology to model (according to Anthony Bell, Thomas Ray)
- According to Thomas Ray, strong AI will need “billions of lines of code”
  - But the genome has only 30-100 million bytes of compressed code
  - The Brain is a recursive probabilistic fractal
    - Example: The Cerebellum

# The criticism from micro tubules and quantum computing

- Human thinking requires quantum computing and that is only possible in biological structures (i.e., tubules) (according to Roger Penrose)
  - No evidence that quantum computing takes places in the tubules
  - Human thinking does not show quantum computing capabilities
  - Even if it were true, it would not be a barrier
    - Would just show that quantum computing is feasible
      - Nothing to restrict it to biological structures

# The criticism from Ontology

- John Searle's Chinese Room:
  - "Because the program is purely formal or syntactical and because minds have mental or semantic contents, any attempt to produce a mind purely with computers programs leaves out the essential features of the mind." - John Searle
    - Searle ignores the *emergent* features of a complex, dynamic system
    - Can apply Searle's argument to show that the human brain "has no understanding"

# Promise versus Peril

- GNR enables our creativity
  - and our destructiveness
- Ethical guidelines *do* work to protect against inadvertent problems
  - 30 year success of Asilomar Guidelines

# Promise versus Peril cont.

- So what about advertent problems (asymmetric warfare)?
  - Designer pathogens, self-replicating nanotech, unfriendly AI (Yudkowsky)....
  - So maybe we should relinquish these dangerous technologies?
  - 3 problems with that:
    - Would require a totalitarian system
    - Would deprive the world of profound benefits
    - Wouldn't work
      - Would drive dangerous technologies underground
      - Would deprive responsible scientists of the tools needed for defense

## Promise versus Peril cont.

- So how do we protect ourselves?
  - Narrow relinquishment of dangerous information
  - Invest in the defenses....

# New York Times Op-Ed "Recipe for Destruction,"

by Ray Kurzweil and Bill Joy, October 17, 2005



## Recipe for Destruction

By Ray Kurzweil  
and Bill Joy

**A**FTER a decade of painstaking research, federal and university scientists have reconstructed the 1918 influenza virus that killed 50 million people worldwide. Like the flu viruses now raising alarm bells in Asia, the 1918 virus was a bird flu that jumped directly to humans, the scientists reported. To shed light on how the virus evolved, the United States Department of Health and Human Services published the full genome of the 1918 influenza virus on the Internet in the GenBank database.

This is extremely foolish. The genome is essentially the design of a weapon of mass destruction. No responsible scientist would advocate publishing precise designs for an atomic bomb, and in two ways revealing the sequence for the flu virus

*Ray Kurzweil, an inventor, is the author of "The Singularity is Near: When Humans Transcend Biology." Bill Joy, founder and former chief scientist of Sun Microsystems, is a partner at a venture-capital firm.*

is even more dangerous.

First, it would be easier to create and release this highly destructive virus from the genetic data than it would be to build and detonate an atomic bomb given only its design, as you don't need rare raw materials like plutonium or enriched uranium. Synthesizing the virus from scratch would be difficult, but far from im-

### Why publish the 1918 influenza genome?

possible. An easier approach would be to modify a conventional flu virus with the eight unique and now published genes of the 1918 killer virus.

Second, release of the virus would be far worse than an atomic bomb. Analyses have shown that the detonation of an atomic bomb in an American city could kill as many as one million people. Release of a highly communicable and deadly biological virus could kill tens of millions, with some estimates in the hundreds of millions.

A Science staff writer, Jocelyn Kaiser, said, "Both the authors and Science's editors acknowledge concerns that terrorists could, in theory, use the information to reconstruct the 1918 flu virus." And yet the journal required that the full genome sequence be made available on the GenBank database as a condition for publishing the paper.

Proponents of publishing this data point out that valuable insights have been gained from the virus's recreation. These insights could help scientists across the world detect and defend against future pandemics, including avian flu.

There are other approaches, however, to sharing the scientifically useful information. Specific insights — for example, that a key mutation noted in one gene may in part explain the virus's unusual virulence — could be published without disclosing the complete genetic recipe. The precise genome could potentially be shared with scientists with suitable security assurances.

We urgently need international agreements by scientific organizations to limit such publications and an international dialogue on the best approach to preventing recipes for weapons of mass destruction from falling into the wrong hands. Part of that discussion should concern the appropriate role of governments, scientists and their scientific societies, and industry.

We also need a new Manhattan Project to develop specific defenses against new biological viral threats, natural or human made. There are promising new technologies, like RNA interference, that could be harnessed. We need to put more stones on the defensive side of the scale.

We realize that calling for this genome to be "un-published" is a bit like trying to gather the horses back into the barn. Perhaps we will be lucky this time, and we will indeed succeed in developing defenses for these killer flu viruses before they are needed. We should, however, treat the genetic sequences of pathological biological viruses with no less care than designs for nuclear weapons. □

Peter Kuper

# “Enough”

- “Is it possible that our technological reach is very nearly sufficient now? That our lives, at least in the West, are sufficiently comfortable.” (Bill McKibben)
- My view: not until we...
  - can meet our energy needs through clean, renewable methods (which nanotech can provide)
  - overcome disease....
    - ...and death
  - overcome poverty, etc.
- Only technology - *advanced, nanoscale, distributed, decentralized, self-organizing, increasingly intelligent technology* - has the scale to overcome these problems.

- Okay, let's say that overcoming disease is a good thing, but perhaps we should stop before transcending *normal* human abilities....
  - So just what is normal?
  - Going beyond "normal" is not a new story.
    - Most of the audience wouldn't be here if life expectancy hadn't increased (the rest of you would be senior citizens)
  - We are the species that goes beyond our limitations
    - We need not define human by our limitations
  - "Death gives meaning to life...and to time"
    - But we get true meaning from knowledge: *art, music, science, technology*

- Scientists: “We are not unique”
  - Universe doesn't revolve around the Earth
  - We are not descended from the Gods
    - But from apes....worms....bacteria...dust
- But we are unique after all
  - We are the only species that creates knowledge....art, music, science, technology...
    - Which is expanding exponentially

# So is the take-off hard or soft?

- Exponential growth is soft...
  - Gradual...
  - Incremental...
  - Smooth...
  - Mathematically identical at each point...
- But ultimately, profoundly transformative

# Reference URLs:

**Graphs available at:**

[www.KurzweilAI.net/pps/26ASC/](http://www.KurzweilAI.net/pps/26ASC/)

**Home of the Big Thinkers:**

[www.KurzweilAI.net](http://www.KurzweilAI.net)