

Autoclave Meltout  
of Cast Explosives

Barry C. McCall  
Tooele Army Depot  
Ammunition Equipment Directorate  
Ammunition Equipment Division  
SIOTE-AEA  
Tooele, Utah 84074

Presented at 27<sup>th</sup>  
Department of Defense Explosive Safety Seminar  
Sahara Hotel and Casino  
Las Vegas, Nevada  
20-22 Aug 1996

# Report Documentation Page

*Form Approved*  
*OMB No. 0704-0188*

Public reporting burden for the collection of information is estimated to average 1 hour per response, including the time for reviewing instructions, searching existing data sources, gathering and maintaining the data needed, and completing and reviewing the collection of information. Send comments regarding this burden estimate or any other aspect of this collection of information, including suggestions for reducing this burden, to Washington Headquarters Services, Directorate for Information Operations and Reports, 1215 Jefferson Davis Highway, Suite 1204, Arlington VA 22202-4302. Respondents should be aware that notwithstanding any other provision of law, no person shall be subject to a penalty for failing to comply with a collection of information if it does not display a currently valid OMB control number.

1. REPORT DATE <b>AUG 1996</b>	2. REPORT TYPE	3. DATES COVERED			
4. TITLE AND SUBTITLE <b>Autoclave Meltout of Cast Explosives</b>		5a. CONTRACT NUMBER			
		5b. GRANT NUMBER			
		5c. PROGRAM ELEMENT NUMBER			
6. AUTHOR(S)		5d. PROJECT NUMBER			
		5e. TASK NUMBER			
		5f. WORK UNIT NUMBER			
7. PERFORMING ORGANIZATION NAME(S) AND ADDRESS(ES) <b>Tooele Army Depot, Ammunition Equipment Directorate, SIOTE-AEA, Tooele, UT, 84074</b>		8. PERFORMING ORGANIZATION REPORT NUMBER			
9. SPONSORING/MONITORING AGENCY NAME(S) AND ADDRESS(ES)		10. SPONSOR/MONITOR'S ACRONYM(S)			
		11. SPONSOR/MONITOR'S REPORT NUMBER(S)			
12. DISTRIBUTION/AVAILABILITY STATEMENT <b>Approved for public release; distribution unlimited.</b>					
13. SUPPLEMENTARY NOTES					
14. ABSTRACT					
15. SUBJECT TERMS					
16. SECURITY CLASSIFICATION OF:			17. LIMITATION OF ABSTRACT	18. NUMBER OF PAGES <b>10</b>	19a. NAME OF RESPONSIBLE PERSON
a. REPORT <b>unclassified</b>	b. ABSTRACT <b>unclassified</b>	c. THIS PAGE <b>unclassified</b>			

## INTRODUCTION

Current methods for the disposal of munitions containing cast explosives (TNT, Comp B, and Tritonal) includes Open Burn/Open Detonation (OB/OD), steam out, wash out and contour drilling. Environmental concerns associated with above methods include air and ground contamination and waste stream treatment. Volume, concentration and toxicity variables have a direct correlation to the economics of disposal.

Autoclave meltout is a demilitarization method that reduces the volume of the waste stream, employs basic industrial technology, and produces a product suitable for reuse. This method is currently in use at Hawthorne Army Ammunition Plant (HWAAP), Nevada and Crane Army Ammo Activity (CAAA), Indiana. The Ammunition Equipment Directorate (AED), Tooele Army Depot, Utah is in the process of developing a standard autoclave system. Candidate munitions and explosives are summarized in Table 1.

Table 1. Candidate Munitions for Autoclave Meltout

Item	Explosive	Explosive Weight (lbs)
90mm Projectiles	TNT, Comp B	2.15
105mm Projectiles	Comp B	5.08
120mm Projectiles	TNT, Comp B	5.26/8.0
155mm Projectiles	TNT	15.5
175mm Projectiles	TNT, Comp B	30.0/31.0
8 inch Projectiles	TNT	36.0
750 lb GP Bomb	Tritonal	386

## BACKGROUND

Previously, the Ammo Peculiar Equipment (APE) 1300 Washout Plant was the only APE designed for large scale recovery of cast explosives. This system uses hot water to erode explosives through the nose or base plugs of projectiles from 75MM to 2000 pound bombs. The process involves loading the items onto a rack, open end down, then onto a washout tank with the openings positioned over jet nozzles. These nozzles direct 180°F water at 100 psi into the cavity, eroding the explosive and allowing it to drop into the washout tank. Through various tanks, kettles, and pelletizing equipment a usable product was recovered. This process creates large amounts of pink water requiring treatment prior to discharge. Pink water is any water contaminated with TNT and is classified as a hazardous waste. Only one APE 1300 Washout Plant is currently operational.

Another method employed at various locations is a steam lance inserted through the nose of the item to also melt and erode the explosive. Through unique fixturing, the condensate/explosive mixture is collected and processed through separation/melt kettles and the explosive is cast into bricks or flaked. This method also produces large quantities of pink water requiring treatment prior to

discharge.

Ravenna Army Ammo Plant pursued autoclave meltout of projectiles and bombs since the 1960's. This equipment has been reinstalled at CAAA and went operational July 1994. It should be noted that fabrication and installation drawings and operational manuals were practically nonexistent for these excess autoclaves. Eleven thousand 175MM projectiles were processed. The autoclaves are being set up to process 750 pound, general purpose bombs at this time.

HWAAP installed autoclave meltout and refining equipment in the late 1970's. This system incorporated larger, improved autoclaves, molten explosive collection piping, vacuum treatment melt kettles, flaker belts, and improved material handling equipment in an integrated system.

During the 1976/1977 period, AED investigated various methods of heating of munitions to meltout cast explosives. Autoclave heating of explosives in sawed projectiles and induction and microwave heating were all investigated. Induction and microwave heating were abandoned during testing phases as a result of hot spot detonation of the munition. Sawing projectiles in half and then heating to remove a slug of explosive proved safe, but the sawing process was deemed as unwarranted for small munitions.

With the emphasis on environmental considerations, Industrial Operations Command assigned Ammunition Equipment Directorate (AED) in 1993 the task to develop and field a standard autoclave system. This system has been designated the APE 1401 Autoclave Meltout System. Emphasis was placed on performance, reliability, maintainability and environmental sensitivity to meet the growing workload for demilitarization and anticipation of greater restrictions on OB/OD.

## **DESCRIPTION OF PROPOSED APE 1401 AUTOCLAVE MELTOUT SYSTEM**

AED visited both operating autoclave facilities to collect performance data, process flow, fabrication methods and recommended improvement data. AED has also visited the proposed first installation site, McAlester Army Ammo Plant, Oklahoma, to discuss proposed workload and inspect available facilities and equipment. Pilot model production and testing was conducted February-June 1995.

The basic autoclave is shown in Figure 1. Emphasis was placed on fabrication economy and catalog available components. Basic design calls for seamless pipe shells, ASME code heads, kits and adapters for various munitions, cooling spray nozzles, and manual and automated controls and timers. Bolted components versus welded components were incorporated to allow adaption flexibility. The autoclaves will be operated at a maximum 15 psig steam pressure. The munitions will be cooked in a melt/drain, vertical position. Molten explosives will be collected and transferred to melt kettles for final processing. The preferred process flow is shown in Figure 2. The final form of the explosive, whether flake, pellet, or cast block, will be determined by the operating facility.

Performance of autoclaves on munitions up to 8 inch projectiles has been established at the other locations. Typical projectile configuration is shown in Figure 3.

Various methods of autoclave meltout of the 750 pound bomb were tested. Initial tests were to cut the base off the bomb at the wax/tritonal interface. The nose piece was removed and the bomb loaded into the autoclave base first with a nozzle inserted into the tail fuze well liner. Live steam was introduced through the arming conduit to be exhausted from the nose liner and circulated around the bomb case. As the explosive melts, it will drain from the base into the collection manifold. Process time at 15 psig, 240°F was 140 minutes. Base melt configuration is shown in Figure 4.

An alternative method tested was internal cutting and partial removal of the nose fuze well. An APE Kit was designed and fabricated using a commercially available internal recessing tool and a steam heated fuze well wrench. This method was required for those installations without a bomb saw. Incidentally, an APE bomb saw is currently being procured and installed at Blue Grass Army Depot. After fuze well removal, the bomb was loaded into the autoclave, nose first, with the nozzle inserted into the nose fuze well. Live steam was introduced through the arming conduit and the explosive melted out. Process time at 15 psig, 240°F was 180 minutes. Nose melt configuration is shown in Figure 5.

Pink water generation was approximately 1 gallons (25 pounds) per hour per autoclave. Production pink water will be treated by carbon filters prior to discharge to plant industrial waste water treatment.

Additional testing efforts pursued were various configurations of molten tritonal collection/separation systems. A trough system was selected to allow the tar from the bombs to be picked out at the completion of each bomb melt. A 5° slope provided enough flow velocity to prevent the aluminum powder component of the tritonal from sedimenting in the trough. Three steam trace lines provided sufficient heat to keep the tritonal molten. The tar would collect in the bottom of the trough and was not substantially melted and eroded by the explosive flow. After collection of the tritonal in the melt kettle, the aluminum powder settled quickly, allowing the TNT to be decanted off the top for separate processing.

Anticipated production rates are shown in Table 2. Anticipated cost for autoclave demilitarization is \$500-\$650 per short ton. Expected pink water generation is approximately 67 pounds per short ton of munition (not net explosive weight). OB/OD costs are approximately \$500 per short ton.

Table 2. Production Rates for Various Items

---

---

Item	Production Rate
90mm Projectiles	8 per 15 min
105mm Projectiles	12 per 20 min
120mm Projectiles	8 per 30 min
155mm Projectiles	6 per 50 min
175mm Projectiles	3 per 60 min
8 inch Projectiles	3 per 75 min
750 lb GP Bomb, Base Cut	1 per 155 min
750 lb GP Bomb, Nose Fuze Well Cut and Removed	1 per 195 min

---

---

Production rate is per autoclave and includes process time plus a load/unload cycle.

The first APE 1401 Autoclave meltout system is being install at McAlester Army Ammunition Plant, at this time. Operation is anticipated in August 1996. Target workload is 105mm, M1, HE projectiles.

## CONCLUSIONS

Autoclave meltout of cast explosives has been demonstrated as an environmentally sensitive alternative for demil. The development of the APE 1401 and associated test reports, technical data package, operational manuals and personnel experienced with the system will provide DoD facilities a standard system for their operations.

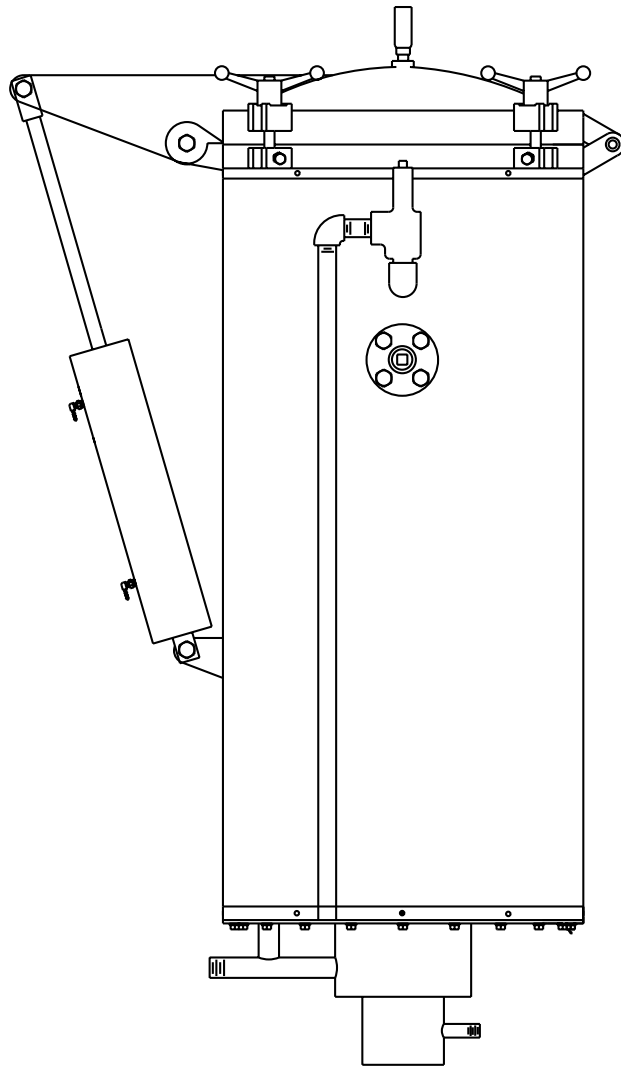

Figure 1. APE 1401 Autoclave.

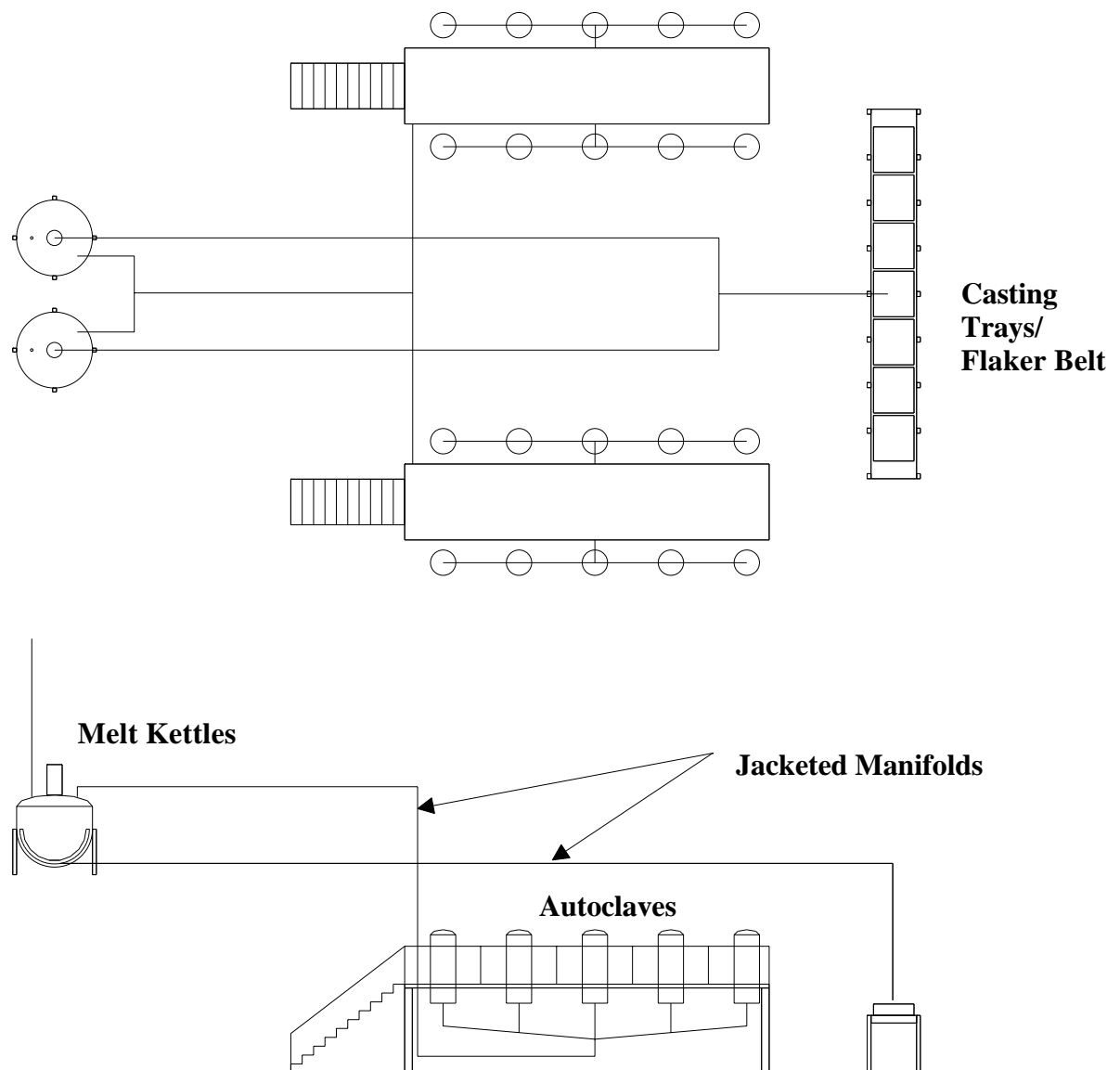

Figure 2. Typical Process Flow.

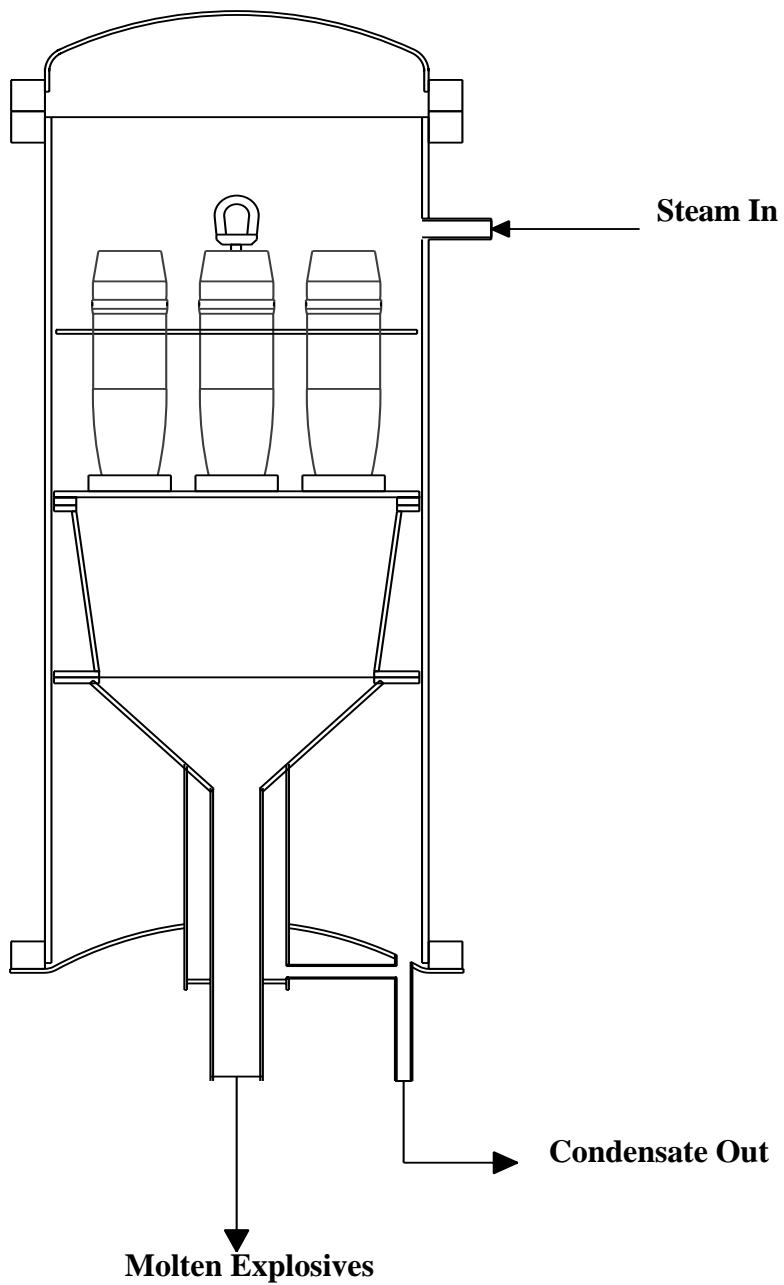

Figure 3. Typical Projectile Meltout Configuration.

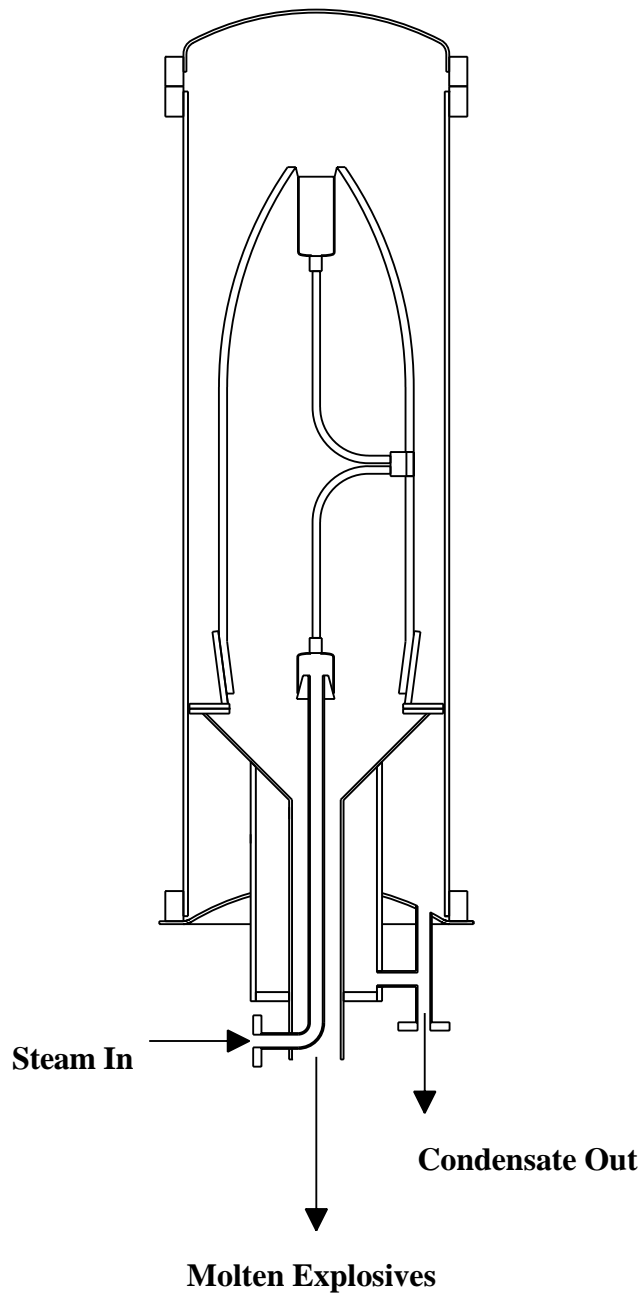

Figure 4. Base Meltout Configuration for 750 Pound, GP Bomb.

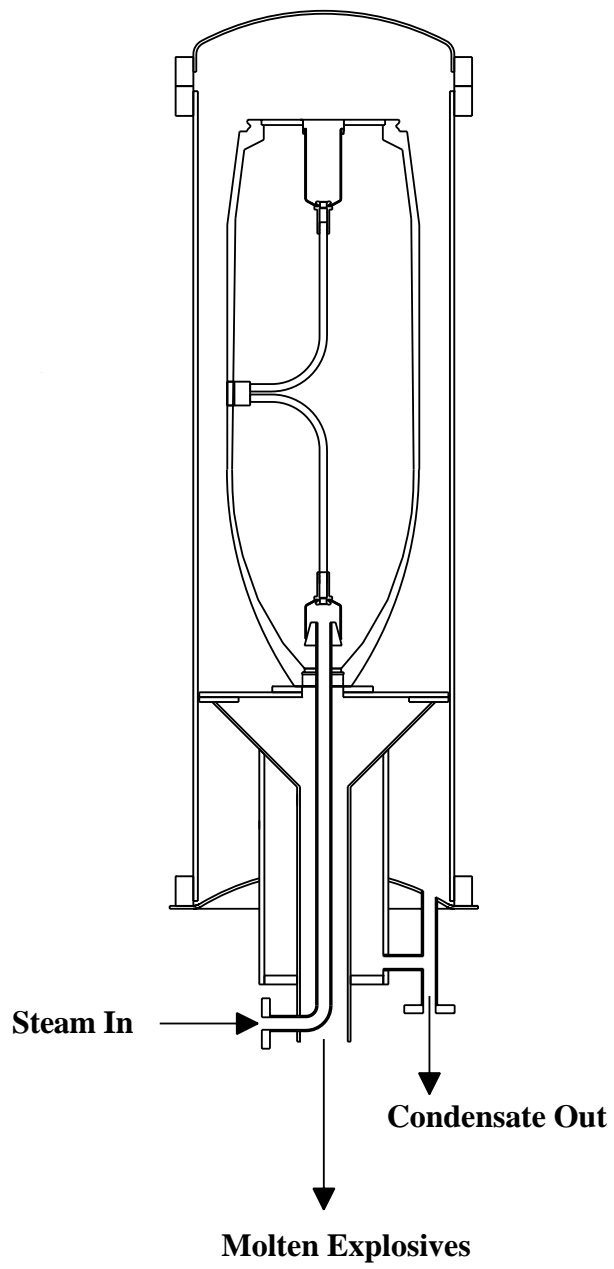

Figure 5. Nose Meltout Configuration for 750 Pound, GP Bomb.