

NPS-PM-06-044



## ACQUISITION RESEARCH CASE SERIES

---

**Lessons Learned from Propulsion System Nozzle Failure on  
Army TACMS**

**14 May 1993**

**by**

**Army TACMS Project Office**

**SFAE-MSL-AT-E**

**Program Executive Office**

**Tactical Missiles**

**Redstone Arsenal, Alabama 35898**

Approved for public release, distribution unlimited.

Prepared for: Naval Postgraduate School, Monterey, California 93943



ACQUISITION RESEARCH PROGRAM  
GRADUATE SCHOOL OF BUSINESS & PUBLIC POLICY  
NAVAL POSTGRADUATE SCHOOL

# Report Documentation Page

Form Approved  
OMB No. 0704-0188

Public reporting burden for the collection of information is estimated to average 1 hour per response, including the time for reviewing instructions, searching existing data sources, gathering and maintaining the data needed, and completing and reviewing the collection of information. Send comments regarding this burden estimate or any other aspect of this collection of information, including suggestions for reducing this burden, to Washington Headquarters Services, Directorate for Information Operations and Reports, 1215 Jefferson Davis Highway, Suite 1204, Arlington VA 22202-4302. Respondents should be aware that notwithstanding any other provision of law, no person shall be subject to a penalty for failing to comply with a collection of information if it does not display a currently valid OMB control number.

1. REPORT DATE <b>14 MAY 1993</b>		2. REPORT TYPE		3. DATES COVERED <b>00-00-1993 to 00-00-1993</b>	
4. TITLE AND SUBTITLE <b>Lessons Learned from Propulsion System Nozzle Failure on Army TACMS</b>				5a. CONTRACT NUMBER	
				5b. GRANT NUMBER	
				5c. PROGRAM ELEMENT NUMBER	
6. AUTHOR(S)				5d. PROJECT NUMBER	
				5e. TASK NUMBER	
				5f. WORK UNIT NUMBER	
7. PERFORMING ORGANIZATION NAME(S) AND ADDRESS(ES) <b>Naval Postgraduate School, Graduate School of Business and Public Policy, 555 Dyer Road, Room 332, Monterey, CA, 93943</b>				8. PERFORMING ORGANIZATION REPORT NUMBER	
9. SPONSORING/MONITORING AGENCY NAME(S) AND ADDRESS(ES)				10. SPONSOR/MONITOR'S ACRONYM(S)	
				11. SPONSOR/MONITOR'S REPORT NUMBER(S)	
12. DISTRIBUTION/AVAILABILITY STATEMENT <b>Approved for public release; distribution unlimited</b>					
13. SUPPLEMENTARY NOTES					
14. ABSTRACT <b>see report</b>					
15. SUBJECT TERMS					
16. SECURITY CLASSIFICATION OF:			17. LIMITATION OF ABSTRACT	18. NUMBER OF PAGES	19a. NAME OF RESPONSIBLE PERSON
a. REPORT <b>unclassified</b>	b. ABSTRACT <b>unclassified</b>	c. THIS PAGE <b>unclassified</b>			

The research presented in this report was supported by the Acquisition Chair of the Graduate School of Business & Public Policy at the Naval Postgraduate School.

**To request Defense Acquisition Research or to become a research sponsor, please contact:**

NPS Acquisition Research Program  
Attn: James B. Greene, RADM, USN, (Ret)  
Acquisition Chair  
Graduate School of Business and Public Policy  
Naval Postgraduate School  
555 Dyer Road, Room 332  
Monterey, CA 93943-5103  
Tel: (831) 656-2092  
Fax: (831) 656-2253  
e-mail: [jbgreene@nps.edu](mailto:jbgreene@nps.edu)

Copies of the Acquisition Sponsored Research Reports may be printed from our website [www.acquisitionresearch.org](http://www.acquisitionresearch.org)



ACQUISITION RESEARCH PROGRAM  
GRADUATE SCHOOL OF BUSINESS & PUBLIC POLICY  
NAVAL POSTGRADUATE SCHOOL

**LESSONS LEARNED  
FROM  
PROPULSION SYSTEM NOZZLE  
FAILURE ON ARMY TACMS**



**14 May 1993**

**Army TACMS Project Office  
SFAE-MSL-AT-E  
PROGRAM EXECUTIVE OFFICE  
TACTICAL MISSILES  
Redstone Arsenal, Alabama 35898**



# TABLE OF CONTENTS

---

	Page
LIST OF ACRONYMS .....	iv
1. INTRODUCTION AND OBJECTIVES .....	1
2. BACKGROUND .....	1
3. DISCUSSION OF FLIGHT NOZZLE FAILURE .....	4
4. DISCUSSION OF ROOT CAUSE .....	11
5. GENERAL INFORMATION ON GRAPHITE .....	17
6. MISSILE INTERIM SPECIFICATION (MIS) FOR GRAPHITE .....	18
7. TESTING BY SOUTHERN RESEARCH INSTITUTE .....	19
7.1 Mechanical and Thermal Evaluations of ATJ and Great Lakes Graphite for ATACMS .....	19
7.2 Mechanical and Thermal Evaluations of Great Lakes H489 Lot 14Y36/15Y3 Graphite for ATACMS .....	28
7.3 Summary .....	28
8. SUMMARY OF FINDINGS .....	29
9. CONCLUSIONS .....	30
10. LESSONS LEARNED .....	31
APPENDIX A — UNION CARBIDE CORPORATION TECHNICAL INFORMATION .....	A-1
APPENDIX B — GREAT LAKES CARBON GRADE H-489 .....	B-1
APPENDIX C — MIS-40130 .....	C-1

## LIST OF ILLUSTRATIONS

Figure		Page
1	Propulsion Section Rocket Motor: XM124 .....	1
2	Army TACMS Missile .....	2
3	Army TACMS Missile (P1170) .....	5
4	Forward View of Boattail Depicting Actuator Controls .....	6
5a	Exit Cone Burnthrough .....	7
5b	Nozzle Exit Cone Assembly Burnthrough .....	8
5c	Inside View of Exit Cone Burnthrough .....	9
6	Solid Rock Motor Without Exit Cone Nozzle .....	10
7	Army TACMS Nozzle Failure Tree .....	12
8	Nozzle Thermal Analysis .....	14
9	Throat Insert O.D. and Surface Temperature @ 6 Sec. ....	14
10	Failure Mode Scenario .....	15
11a	Tensile Strengths of ATJ Graphite .....	17
11b	Compressive, Shear, Bearing and Flexural Strengths of ATJ Graphite .....	18
12	ATJ Micrograph in the With-Grain Orientation at 100x .....	21
13	Great Lakes Graphite Micrograph in the With-Grain Orientation at 100x .....	22
14	Across and With-Grain Thermal Expansion of ATJ Graphite to 500°F (ATJ-3) .....	26
15	Across and With-Grain Thermal Expansion of Great Lakes Graphite to 5000°F (GL-3) .....	26
16	With-Grain Thermal Expansion Comparison of ATJ and GL Graphite to Historical Graphite and Graphnol .....	27
17	Across-Grain Thermal Expansion Comparison of ATJ and GL Graphite to Historical Graphite and Graphnol .....	27

## LIST OF TABLES

Table		Page
1	Graphite Lot Mechanical Properties Comparison .....	3
2	Chemical and Physical Properties .....	4
3	Graphite Laboratory Test Results/Samples Cut From Insert .....	13
4	Predicted Insert Safety Factors .....	15
5	Additions to MIS-40130 .....	19
6	Test Matrix for ATJ and Great Lakes Graphite .....	20
7	Tensile Evaluations of ATJ and Great Lakes Graphite Materials to 5000°F .....	23
8	Tensile Evaluations of ATJ and Great Lakes Graphite Materials at Room Temperature .....	23
9	Summary of Tensile Stress-Strain Data for the Average Curves of Graphite and Graphnol Material .....	24
10	Compressive Evaluations of ATJ and Great Lakes Graphite Materials to 5000°F .....	25
11	Summary of Compressive Stress-Strain Data for the Average Curves of Graphite and Graphnol Material .....	25
12	Test Matrix for Great Lakes H489 Lot 14Y36/15Y3 Graphite Material .....	28

## LIST OF ACRONYMS AND ABBREVIATIONS

---

ARC	Atlantic Research Corporation
CT	Computer Topography
ECP	Engineering Change Proposal
F	Fahrenheit
FRP	Full Rate Production
FSD	Full Scale Development
GL	Great Lakes
GLC	Great Lakes Carbon
IAW	In Accordance With
LRIP	Low Rate Initial Production
MICOM	Missile Command
MIS	Missile Interim Specification
M/LPA	Missile Launch Pod Assembly
NASA	National Aeronautics and Space Administration
RDEC	Research, Development and Engineering Center
RFP	Request for Proposal
SRI	Southern Research Institute
SRM	Solid Rocket Motor
TACMS	Tactical Missile System
UC	Union Carbide
WSMR	White Sands Missile Range
ZCP	Zinc Chromate Putty

## 1. INTRODUCTION AND OBJECTIVES

This report finalizes the lessons learned, that was initially reported on in a preliminary report on 29 May 1992, from a propulsion system flight nozzle failure during a flight test at White Sands Missile Range (WSMR), New Mexico on 4 September 1991.

The Army Tactical Missile System (Army TACMS) propulsion system nozzle assembly (see Figure 1) included a graphite throat insert, a silica phenolic throat insert (MX-2675), and a throat insert insulator (Fiberite MX-4926), supported by an epoxy and a throat assembly bonded with an EA-934 adhesive.

This report contains material obtained through interviews with current and former Army TACMS, Research, Development and Engineering Center

(RDEC), and support personnel associated with the program; reviewing documents generated by the Army TACMS Project Office, LTV and Southern Research Institute (SRI); and open literature regarding the use of graphite.

The objective of this report is to thoroughly delineate the cause of the failure, document the lessons learned and make widespread dissemination of the information in order to help other project offices avoid a similar occurrence. There is no intention in this document to cast blame on any Government organization or private contractor.

## 2. BACKGROUND

The Army TACMS is an inertially guided missile system designed to attack enemy forces at ranges beyond the capability of existing cannons and rockets (Figure 2).

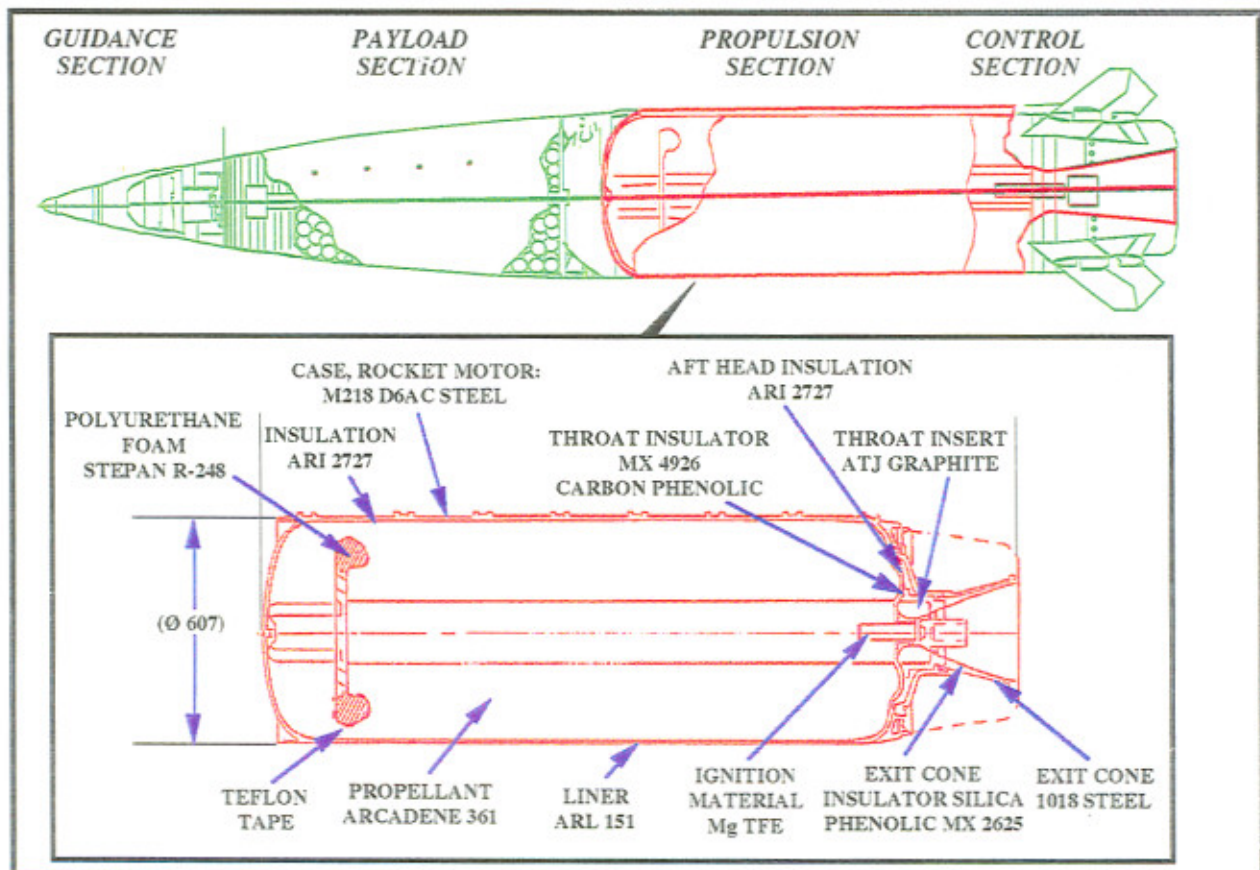

Figure 1. Propulsion Section Rocket Motor: XM124

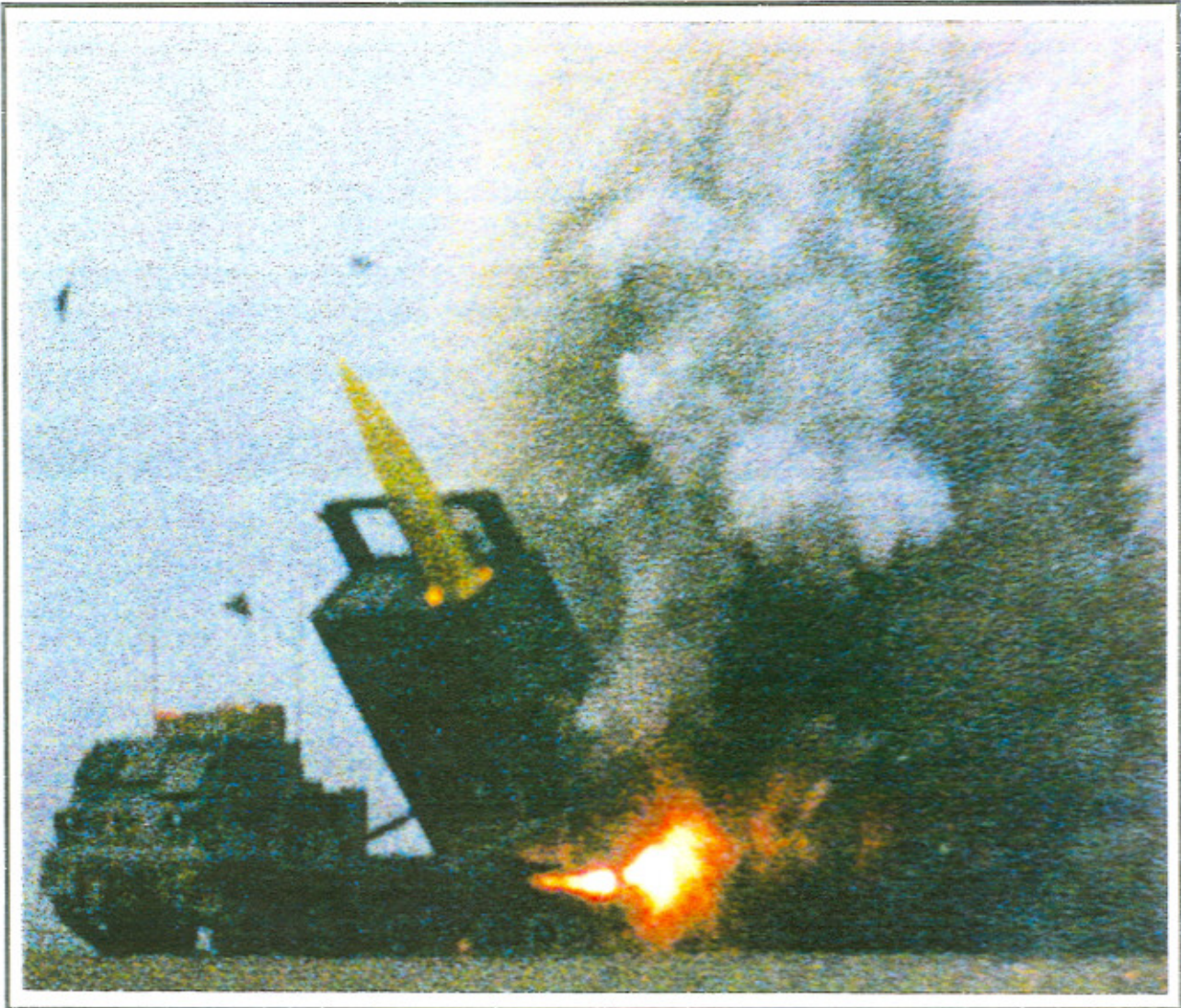

Figure 2. Army TACMS Missile

A competitive Request For Proposal (RFP) from industry for Full-Scale Development (FSD) of the Army TACMS Missile Launch Pod Assembly (M/LPA) and a sole source RFP for integration of the M/LPA with the M270 launcher were released in June 1985. LTV Corporation's Missiles and Electronics Group was the winner of the competition for the development of the M/LPA. In March 1986, firm fixed price contracts were awarded to LTV for both the development and integration efforts.

Developmental testing of Army TACMS began at WSMR in April 1988 and ended in March 1990. Operational testing followed immediately

after developmental testing and was completed in June 1990.

The contract for Low Rate Initial Production (LRIP) for 66 missiles was awarded in February 1989. A second LRIP for 104 missiles was authorized by an Army Acquisition Executive Panel Review and a contract was awarded to LTV in February 1990. The first production missiles were accepted in March 1990. In November 1990, the Defense Acquisition Board approved Army TACMS for Full Rate Production (FRP), and the contract for the first year of FRP was awarded to LTV.

Atlantic Research Corporation (ARC) has manufactured Army TACMS rocket motor nozzles using two grades of graphite that meet the chemical and mechanical requirement of Missile Interim Specification (MIS) 29147. During the FSD and qualification program phases, graphite manufactured by Union Carbide (UC) Corporation (designated TS-1792) was used. TS-1792 is the UC grade of graphite that has replaced their ATJ grade. TS-1792 is isostatically molded and has relatively uniform and isotropic material properties. Late in the FSD delivery program phase and continuing into the LRIP-1 and LRIP-2 program phases, the nozzle inserts were manufactured using graphite manufactured by Great Lakes Carbon (GLC) Corporation (designated H-489). GLC H-489 is not isotropic primarily due to the aspect ratio of the particles. Table 1 provides information obtained from ARC production records on graphite lot mechanical property comparisons.

The Army TACMS product drawing for the solid rocket motor is Part Number 13287245. This drawing specified the material to be graphite in

accordance with (IAW) MIS-29147. MIS-29147, "Missile Command Specification for Graphite, Molded, for High Temperature Application" is dated 7 November 1979, and was the specification used for purchase of graphite. This MIS was originally developed for the Chaparral Missile Program. The chemical and physical properties (See Table 2) listed in the specification are to conform to values of apparent density, specific resistance, with the grain and across the grain flexural strength, and ash content. The specification's suggested source is ATJ Graphite produced by UC. Both UC and GLC manufactured graphite met the requirements of this specification. See Appendices A and B.

The material purchased to the MIS specification has been tested approximately 127 times. Testing started in September 1986 with the heavy wall development motors. These include a total of 92 nozzles (Lot A7C25819) using UC TS-1792 graphite. Of the 92 nozzles, 72 have been tested successfully, including 19 during the qualification testing. In addition, during the LRIP-1 program,

TABLE 1. GRAPHITE LOT MECHANICAL PROPERTIES COMPARISON

PROGRAM	MFG	ARC IR #	LOT	GRAIN DIRECTION	APPARENT DENSITY, (G/CC)	ELECTRICAL RESISTIVITY, (OHM-CMX10 <sup>-4</sup> )	FLEXURAL STRENGTH, (PSI)	ASH (%)	INSERTS
				WITH	1.70 to 1.83	13.0 Max.	2600 Min.	0.25 Max.	
				AGAINST		17.0 Max.	2400 Min.		
FSD	UCAR	A7C25819	C-76	WITH	1.75	10.16	4362	0.0635	100
				AGAINST	1.78	9.78	4254		
			C-74	WITH	1.77	9.45	4249	0.049	
				AGAINST	1.77	11.28	3937		
			C-75	WITH	1.73	10.87	4208	0.043	
				AGAINST	1.73	11.67	3502		
LRIP I	GLC	A9C27351	14Y36	WITH	1.72	13.36	3979	0.20	100
					1.71				
					1.70				
			AGAINST	---	16.21	3109			
			15Y3	WITH	1.72	12.98	3993	0.17	
				AGAINST	---	15.52	3307		
LRIP II	GLC	A0C29012	35W52	WITH	1.71	11.61	4092	0.13	117
				AGAINST	---	15.90	2497		
			31W27	WITH	1.73	11.58	4277	0.20	
				AGAINST	---	16.56	3485		
FSP I	UCAR	A1C62308-01-04	C-130	WITH	1.75	10.76	4270	0.058	125
				AGAINST	---	10.21	4270		
		A1C62308-01-03	C-114	WITH	1.76	---	4254	0.094	4
				AGAINST	---	---	4408		
	GLC	A1C62308-01-01	51W52	WITH	1.72	12.40	3861	0.18	50
				AGAINST	---	16.97	2721		
		49W21	49W14	WITH	1.72	12.60	3601	0.14	120
				AGAINST	---	13.20	2898		
A1C62308-01-02	49W14	---	1.73	---	---				

**TABLE 2. CHEMICAL AND PHYSICAL PROPERTIES**

PROPERTY		VALUES	
		MINIMUM	MAXIMUM
APPARENT DENSITY, GRAMS/CUBIC CENTIMETER		1.70	1.83
SPECIFIC RESISTANCE, OHM-CM X 10 <sup>-4</sup>	WITH THE GRAIN	---	13.0
	ACROSS THE GRAIN	---	17.0
FLEXURAL STRENGTH, PSI	WITH THE GRAIN	2600	---
	ACROSS THE GRAIN	2400	---
ASH CONTENT, PERCENT		---	0.25

92 nozzles were manufactured from GLC graphite lot AOC27351. From this lot of H-489 graphite, 40 motors have been test fired successfully, 27 times in Southwest Asia, 12 flights at WSMR and one static test. The H-489 graphite was used in a ground test static firing to verify the Norris case for Army TACMS use. This motor test was successfully conducted on 25 October 1989. Based on this demonstrated experience, graphite from both suppliers was considered to be qualified for motor insert use.

A second lot of H-489 graphite, AOC29012, was delivered and used to manufacture 114 nozzles. A total of eight motors from this lot has been tested. Seven tests resulted in the motor meeting all performance requirements and/or successful completion of its mission. An eighth nozzle manufactured from this lot of graphite was used in the flight test burnthrough failure. The motor, S/N 215098, was used in missile P-1170.

### **3. DISCUSSION OF FLIGHT NOZZLE FAILURE**

An Army TACMS Missile (P-1170) was fired from a 5 ton truck with a modified Honest John launcher on 4 September 1991. During the early portion of the flight (approximately 6 seconds into the burn stage) a large quantity of debris expelled

from the nozzle (Figure 3). This was followed by a small quantity of debris at approximately 7 seconds (Figure 3), and a medium to large quantity of debris at about 8.5 seconds (Figure 3). The flight accelerations and velocities appeared normal until 23 seconds, when deceleration occurred and loss of telemetry data happened at 23.2 seconds. At 23 seconds hot gas (approximately 5000°F) had entered the boattail (Figure 4) area via burnthrough and eliminated power to the missile guidance system by damaging the electronic battery and cables. After the loss of data at 23.3 seconds, the missile continued on a ballistic flight path for an additional 10,000 feet. At the end of burn the missile spiraled to earth and landed 10 miles short of the target.

Close examination of the recovered hardware revealed:

- a. A two inch hole burned through the nozzle at the joint between the insert insulator and the exit cone insulation. Burn through appeared as a "V" shape with the wide part of the "V" at the head of the exit cone and the tip of the "V" ending just below the threaded area. (See Figure 5a). Another view is shown in Figure 5b with the nozzle section adjacent. Figure 5c provides an inside view of the burnthrough along with a head-on view of the aft closure. The entire Solid Rocket Missile (SRM) without the nozzle is shown in Figure 6 (note the burnthrough on the lower side of the exit cone).
- b. All of the graphite throat was missing.
- c. The insert insulator was broken into several pieces (ejected forward into the case on impact).
- d. The motor case and insulation looked normal.

On 10 October 1991, a motor (S/N 215109) that was manufactured on the same day as the failed motor was static tested at ARC and met all

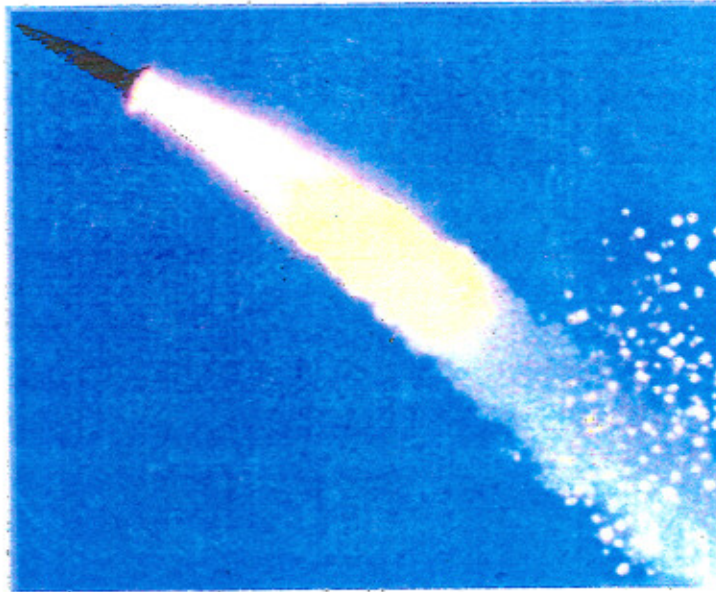

**AFTER 8.5 SEC**

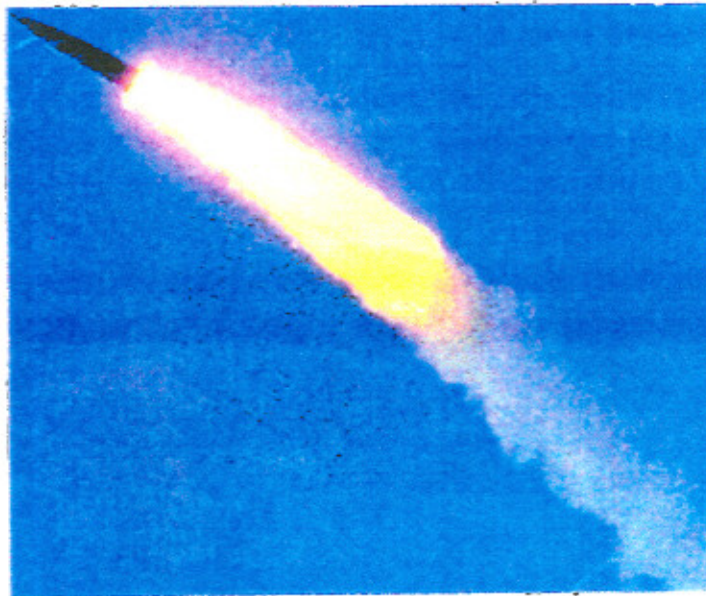

**AFTER 7 SEC**

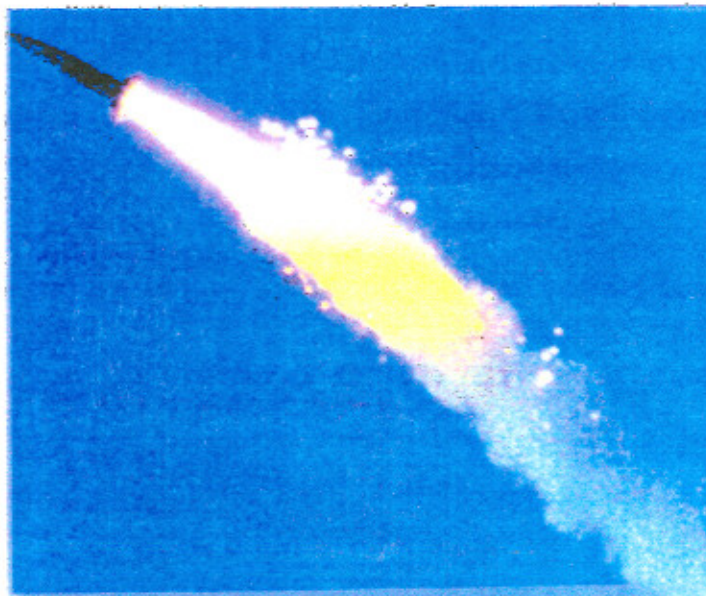

**AFTER 6 SEC**

**Figure 3. Army TACMS Missile P1170**

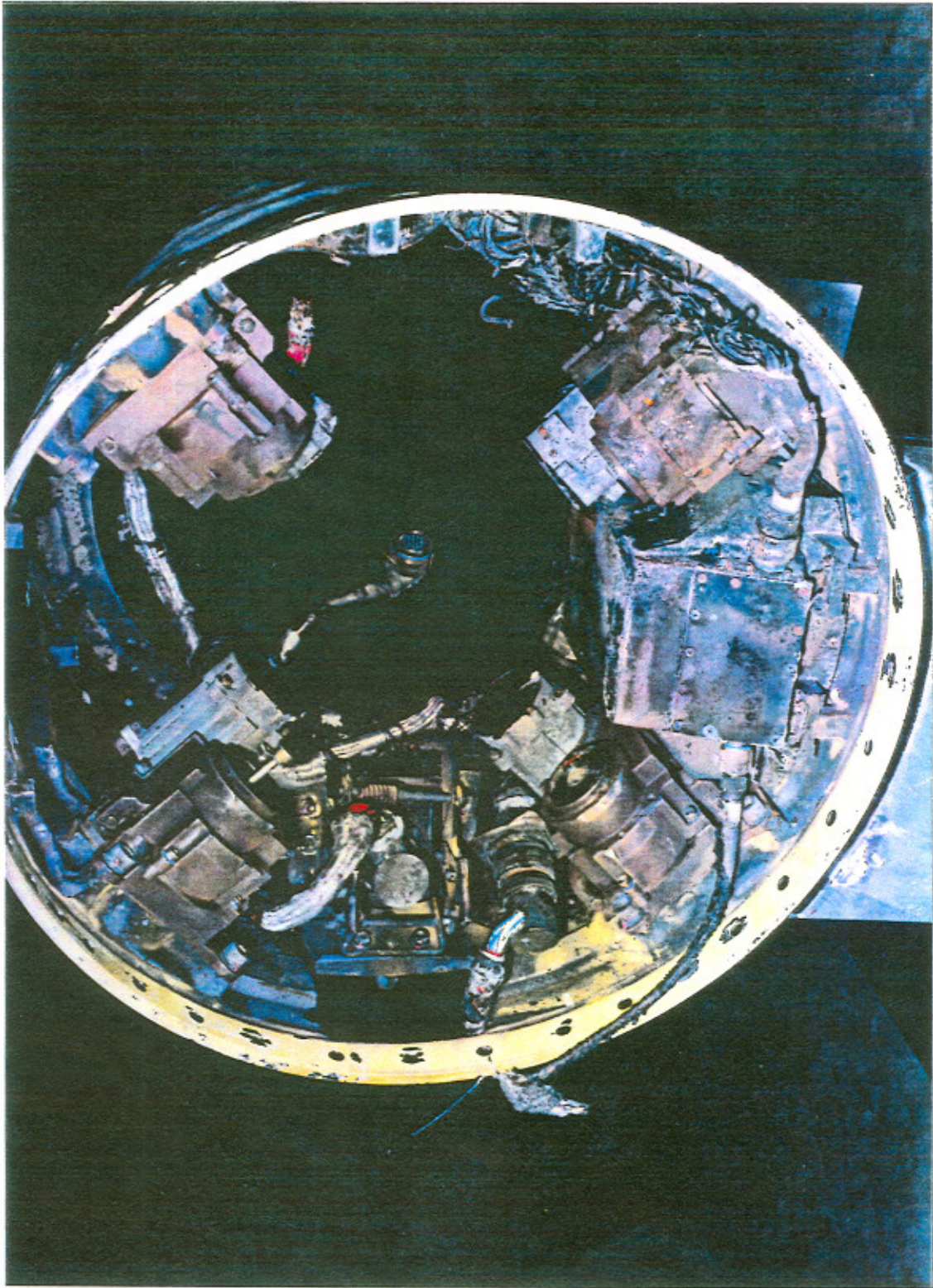

Figure 4. Forward View of Boattail Depicting Actuator Controls



Figure 5a. Exit Cone Burnthrough



Figure 5b. Nozzle Exit Cone Assembly Burnthrough



Figure 5c. Inside View of Exit Cone Burnthrough



Figure 6. Solid Rock Motor Without Exit Cone Nozzle

specification requirements. The results of that test was: (1) No hot spots were on the exterior of the exit cone, however, (2) Pieces of graphite were ejected at approximately 6 seconds and at various points of time during the static firing very similar to the flight of 4 Sep 91. Erosion of the throat was excessive in comparison to the TS-1792. The erosion occurred approximately 120 degrees apart and on the down stream side of the throat. The exit cone and necessary parts of the missile were disassembled to install the destruct package, and the correct installation of the zinc chromate putty was in question.

#### **4. DISCUSSION OF ROOT CAUSE**

A root cause failure investigation was ordered by the Army TACMS Project Office immediately after the failure. LTV and ARC performed this detailed analysis with active involvement by Army TACMS Project Office, RDEC, and support contract personnel. The basic plan developed for arriving at the root cause of the failure included: (1) recover and examine failed parts, (2) collect and review video and telemetry data, (3) collect and review nozzle manufacturing, inspection and handling records, (4) review nozzle history, (5) generate fault tree, (6) eliminate low probability failure modes based on review of existing data, (7) identify/collect/generate additional data, tests, and analyses needed to confirm or refute remaining failure modes, (8) rank candidate root causes identifying most probable cause(s), and (9) determine and implement corrective action.

Hardware was collected and video and telemetry data were reviewed IAW the basic plan to assist in determining root cause of the failure.

The process and inspection review revealed the following:

a. Adhesives - All adhesives used were "A" status (acceptable) and met shore hardness requirements. Cure times were recorded on all

bonded parts, and the presence of adhesives was verified on all bonded parts.

b. O-rings - All O-rings were "A" status. The O-rings were verified to be within shelf life and had been coated with silicon grease per production procedures.

c. Igniter Enclosure - Raw material was verified acceptable before use and there was no significant variation in raw material physical properties. In addition, there was no change in molding processes. Parts were inspected and cleaned after machining per drawing and all parts were proof pressure tested.

d. Graphite Inserts - All parts were received from the vendor on a certificate of compliance. All inserts were bought to Missile Command (MICOM) Specification, for Graphite, Molded for High Temperature Application, MIS-29147 dated 7 November 1979. Graphite was purchased from UC and GLC.

e. Throat Insulator - FSD throats were made primarily by American Automated and all throats were molded from the same mold. Specific gravity and density on all parts were verified and recorded and there was no significant variation.

f. Exit Cone - All raw materials were determined to be acceptable and there were no changes in the molding process. Specific gravity and density on all parts were verified. There were no significant changes in the assembly processes. Coverage of adhesive was verified and all cure times were recorded.

g. Throat Assemblies - All materials were verified as being acceptable and the process had no significant changes. Adhesive coverage verified prior to assembly and the throat assembly was covered with EP-56 epoxy. All throats were leak checked prior to acceptance.

Members of the Root Cause Team went to GLC and Machined Graphite Products to gain greater insight into possible causes of the failure. The Team determined: (1) grain direction is clearly marked on each piece of graphite, as well as the lot and piece number, (2) GLC graphite supplied was not isotropic primarily due to the aspect ratio of the particles, (3) samples are taken from the ends of a block for the Army TACMS program, (4) a lot of graphite is a sequential production of material between mixer cleanout, and pieces from the same lot may not be graphitized at the same time or in the same furnace, (5) Machined Graphite Products can not identify from what block of graphite a throat came from, if more than one block of graphite is used in a shipment for the Army TACMS program (indicates a requirement for serialization), and (6) Machined Graphite Products rejects approximately 1 percent of inserts for another program due to flaws found dur-

ing X-ray. GLC encouraged a switch from H-489 graphite to another graphite product (GLC 490).

An Army TACMS Nozzle Failure Tree was developed (See Figure 7). The following rationale was provided for elimination of failure modes:

a. Graphite Failure

(1) Billet Size - Data indicates billet size does not significantly affect properties.

(2) Igniter Mount - Material meets specification. Eject pressure met design requirements. No structural damage to graphite insert.

(3) Initial Defect - X-ray of greater than 100 parts shows no defects.

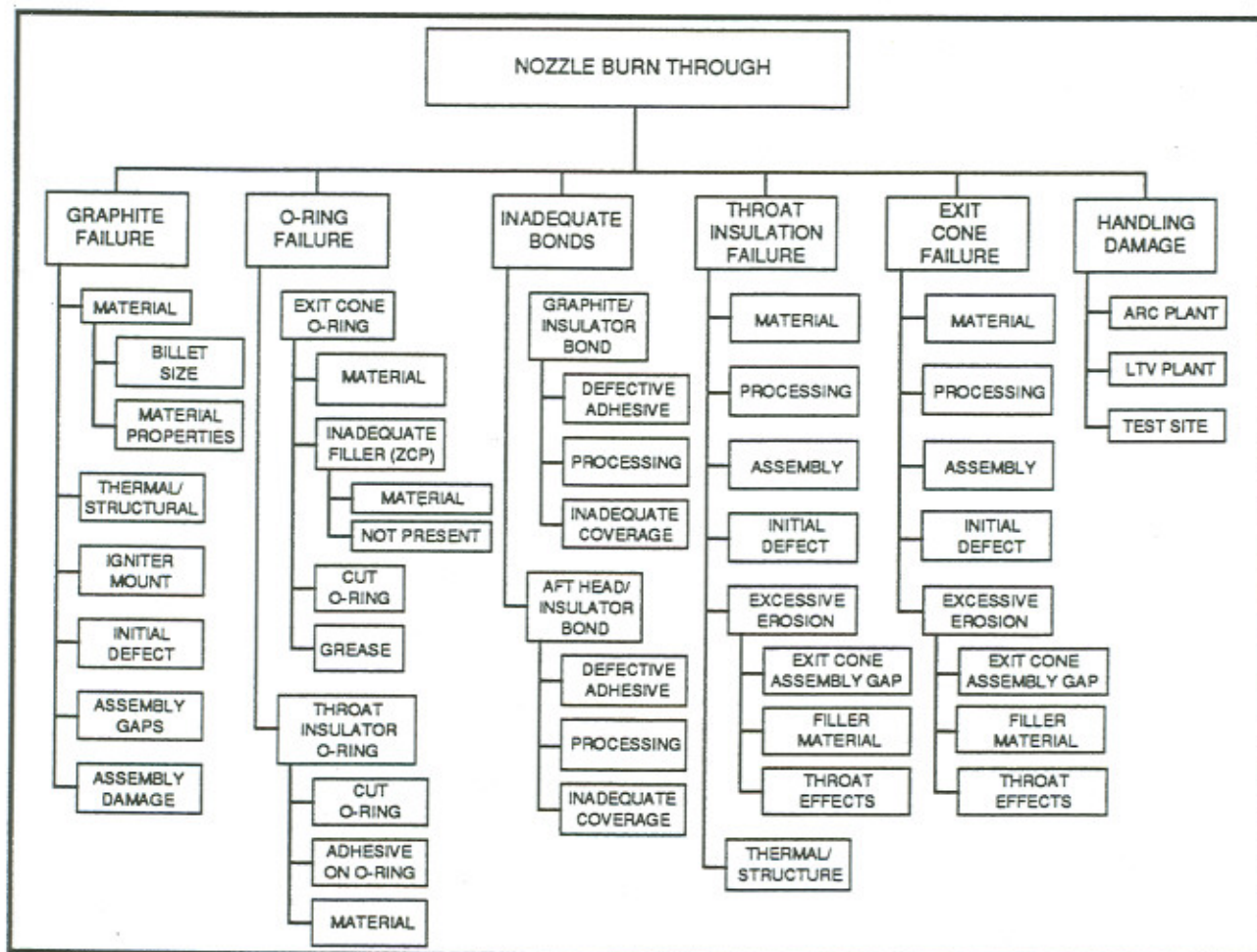

Figure 7. Army TACMS Nozzle Failure Tree

(4) Assembly Gaps - Inspection records show all dimensions and gaps meet drawing requirements.

(5) Assembly Damage - Review of processes show no evidence of any anomalies.

b. O-Ring Failure

(1) Exit Cone O-Ring - Zinc Chromate Putty (ZCP) present. All materials meet requirements. Thermal analysis shows insignificant O-ring or throat insulation temperature rise at 6.0 seconds if ZCP was absent.

(2) Throat Insulation O-Ring - O-Ring present after test. Material meets specification. No indication of flow between parts.

c. Inadequate Bonds

(1) Graphite/Insulator Bond - No indication of gas flow between parts.

(2) Aft Head/Insulator Bond - No indication of gas flow between parts.

d. Throat Insulation Failure - Material meets all requirements. All parts manufactured in same

mold with the same processing parameters. Test show as-molded strengths meet requirements. Resin volatiles equal 2 percent or less. Lack of chamfers has no significant structural effect.

e. Exit Cone Failure - Review of all processing and inspection records show no anomalies. Recovered hardware shows no evidence that failure initiated in exit cone.

f. Handling Damage - Process had no significant changes and all materials used were verified acceptable. Adhesive coverage was verified prior to assembly. The throat assembly was covered with EP-epoxy, and all throats were leak checked prior to acceptance.

ARC conducted a series of laboratory tests from graphite samples cut from inserts supplied by both UC and GLC. Results of that testing are shown in Table 3. Results of the testing clearly indicated that graphite supplied by UC has greater flexural and compressive strengths and that wide variations existed among GLC lot numbers.

Following testing, ARC conducted a thermal analysis using SAAS III finite element computer code (See Figures 8 and 9). Thermal gradients of 2, 4, and 6 seconds were used based on 70°F nominal firing data.

TABLE 3. GRAPHITE LABORATORY TEST RESULTS/SAMPLES CUT FROM INSERT

MFG	ARC IR#	BLOCK NUMBER	PROGRAM/ INSERTS	FLEXURAL (PSI) ACROSS GRAIN	COMPRESSION (PSI) W/GRAIN	A/GRAIN
UC	A1C62308-01-04	C-130	FSP 1 (125)	4975(3)	9645(3)	9753(3)
	A1C62308-01-03	C-114	FSP 1 (4)	3820(3)*	9550*	8662*
UC	A1C62308-01-01	51W52	FSP 1 (50)	3489(3)	7880(3)	7515(3)
GLC	A1C62308-01-02	49W21	FSP 1 (120)	3429(3)	6048(3)	6057(3)
	A0C29012	35W52	LRIP II (117)		TBD***	
GLC		31W27		3285(3)**	8026(3)**	8198(3)**
	A9C27351	14Y36	LRIP 1 (100)		TBD***	
GLC		15Y3				
* UNION CARBIDE DATA FROM BLOCK ** FIRED INSERT, IDENTIFIED BY FLEX TEST *** MATERIAL NOT AVAILABLE						

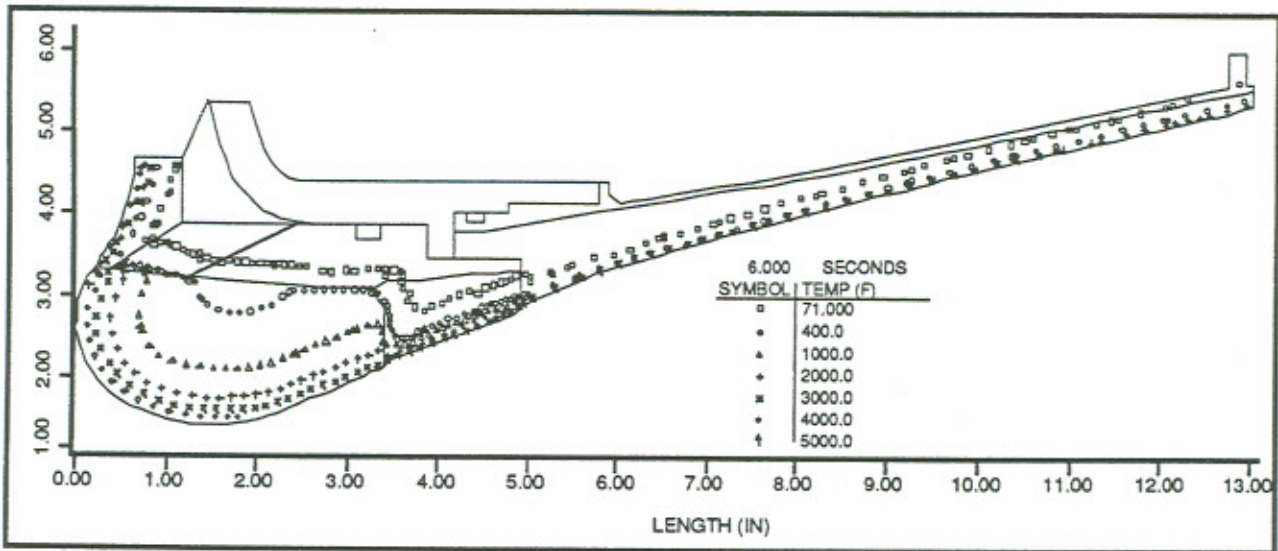

Figure 8. Nozzle Thermal Analysis

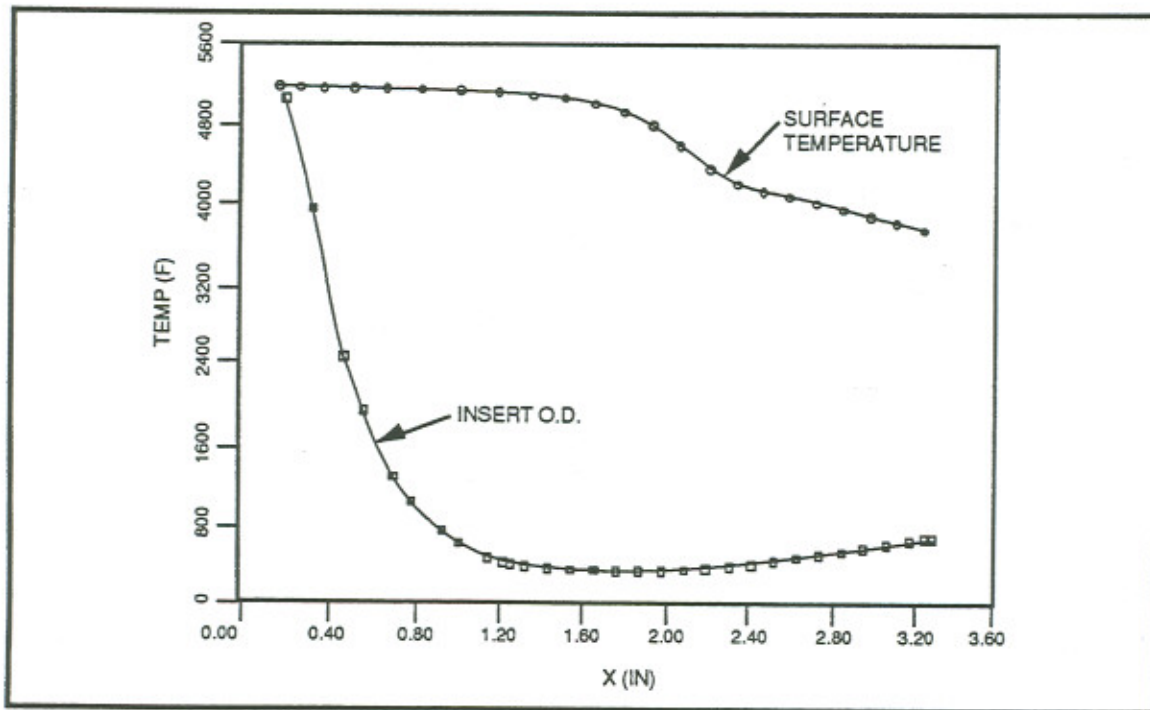

Figure 9. Throat Insert O.D. and Surface Temperature @ 6 Sec.

Stress - strain curves, modulus, coefficient of thermal expansion, and strengths were considered.

The structural analysis pointed out that the critical stress state is compression stresses at the inner surface of the insert and down stream of the throat. The analysis also determined that the safety factor is reduced by 22 percent when GLC graphite is substituted for the UC ATJ graphite.

Table 4 provides predicted insert safety factors for both UC and GLC graphite. The numbers shown are based on vendor and ATJ variability data.

ARC concluded that the root cause was compressive failure of the graphite throat insert. The failure mode scenario is shown in Figure 10.

TABLE 4. PREDICTED INSERT SAFETY FACTORS

MATERIAL	ALLOWABLE COMPRESSIVE STRENGTH (PSI) 70° F	SAFETY FACTOR (4500°F)**
<u>UNION CARBIDE</u>		
MIN. STRENGTH*	8000	1.45
MAX. STRENGTH*	10000	1.81
BLOCK C-1390 (FSP-I)	9700	1.76
<u>GREAT LAKES CARBON</u>		
MIN. STRENGTH*	6000	1.09
MAX. STRENGTH*	8000	1.45
BLOCK 51W52 (FSP I)	7700	1.39
BLOCK 35W52 (LRIP II)	TBD	TBD
BLOCK 31W27 (LRIP II)	8100	1.47
BLOCK 14Y36 (LRIP I)	TBD	TBD
BLOCK 15Y 3 (LRIP I)	TBD	TBD
* BASED ON VENDOR AND ATJ VARIABILITY DATA		
** BASED ON ATLANTIC RESEARCH ANALYSIS		

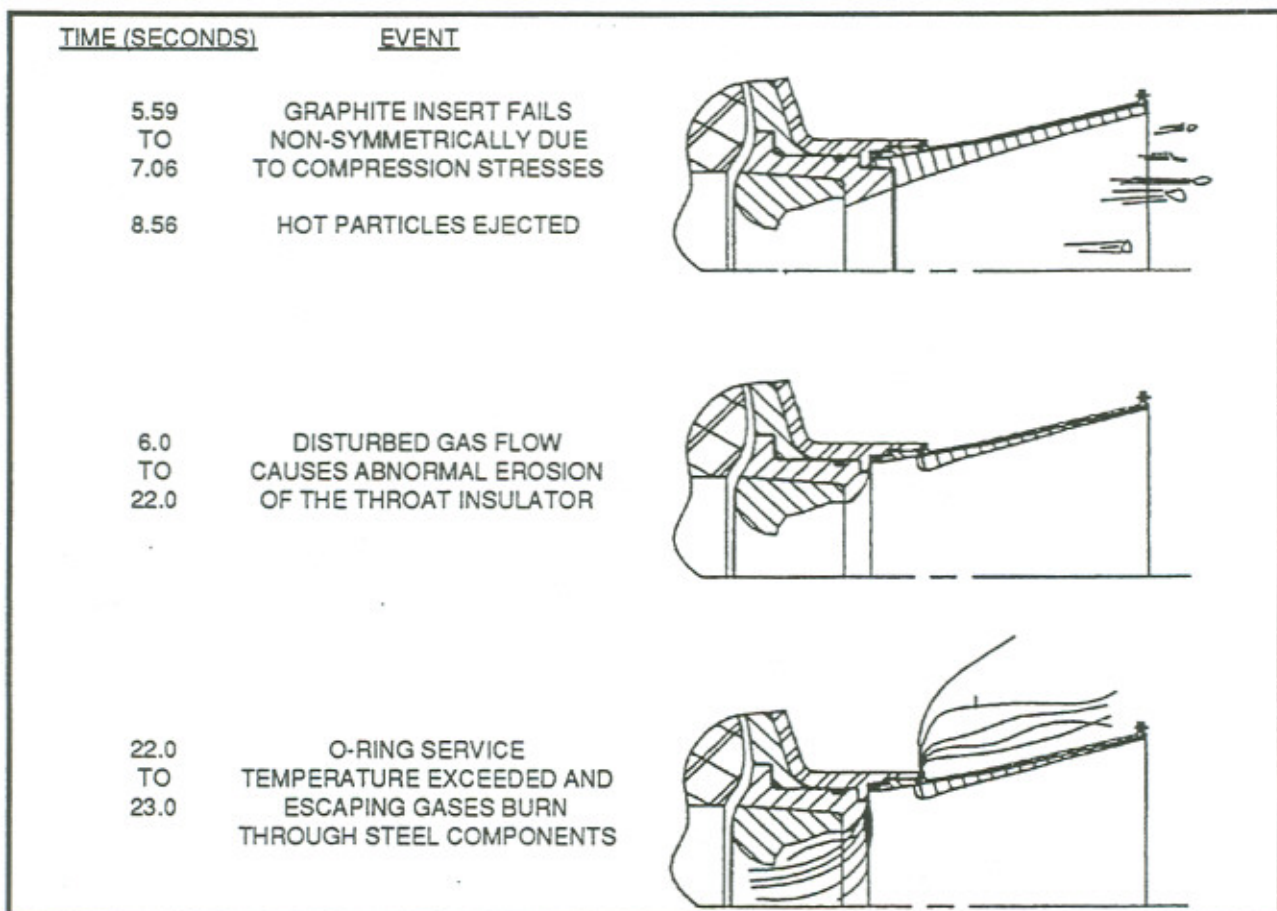

Figure 10. Failure Mode Scenario

The corrective actions recommended by ARC and LTV and approved by the Project Manager included both short- and long-term solutions. The short-term actions were:

1. Discontinue use of GLC inserts in motor deliveries.
2. Deliver all future motors with UC inserts.
3. 100 percent x-ray of throat inserts.
4. Get flexural and compressive strength measurements on current graphite throat inserts.

The long-term actions were:

1. Continue investigation to determine the minimum acceptable properties for graphite inserts.
2. Improve lot traceability by serializing individual parts.
3. Revise MIS-29147 specification for Army TACMS to include additional samples and comprehensive strength.
4. Change drawing to impose 100 percent x-ray of graphite throats.

The Propulsion Directorate, on 21 October 1991, expressed concern that the ARC analysis did not accurately define the structural integrity of the throat insert under static/flight test conditions. They stated, "Minimal mechanical property data points, improperly extrapolated high temperature data, and incorrect application of data to analysis by ARC have resulted in positive safety margins that are fictitiously high." Propulsion Directorate recommended that they be funded to perform thermostructural analysis to define the state of stress and safety factors in the throat insert.

Chief, Army TACMS, Technical Management Division expressed reservations regarding the ARC analysis. He was concerned that the analysis may have in-fact improperly extrapolated the high

temperature data. This concern was based upon the considerable amount of test data on graphite that was generated by SRI in support of the National Aeronautics and Space Administration (NASA) castor motor program. He agreed that the Propulsion Directorate should conduct an independent analysis and further recommended that SRI be tasked to conduct tests of compressive and tensile strengths at ambient and elevated temperatures. Army TACMS Project Office subsequently funded both of these efforts.

The significance of the test and further analysis was that if the safety margins were proven to be inadequate, at the higher temperatures, another material other than graphite could be required and all of the fielded Army TACMS missiles might require retrofit.

Following a series of meetings and discussions, on 26 November 1991, LTV and ARC presented information and rework plans for all LRIP II and FSP nozzles containing GLC H-489 graphite. They recommended the rework of 117 motors containing H-489 graphite from lots 35W52, 31W27, 51W52, 49W14, and 49W21. They did not recommend that the LRIP I motors containing H-489 lots 14Y36 and 15Y3 be reworked. LTV's test data and extensive flight program results proved it to be an acceptable lot. In addition, data presented 15 Apr 93 to Program Manager and Deputy Program Manager summarizing all accumulated information and data showed a positive margin of safety in excess of the structural requirements for the 14Y36 and 15Y3 lots.

Program Manager Army TACMS, Col David Matthews, directed that the plan to rework the 117 motors that was recommended by LTV and ARC be implemented. Eighteen motors were to be returned to ARC. Two motors had already been reworked to support testing. Forty-six were to be reworked at WSMR, 40 were to be reworked at Weilerbach, and 31 were to be reworked at Anniston Army Depot. The three thought to be in long-term storage in Panama and Sececa were not

to be reworked at the time; however, three new aft closure kits were to be provided to Redstone Arsenal. Subsequently it was determined that the three rounds had not been shipped to Panama and Sececa and would be reworked.

## 5. GENERAL INFORMATION ON GRAPHITE

The properties of graphite differ widely, not only between different grades, but between lots. Additional variations in properties may be found between different pieces in a given lot as well as between locations and orientations within a single block. This wide variation is due to the sensitivity of graphite properties to many variables. These variables include differences in starting materials, particle size, forming method, condition of the first bake, and graphitizing conditions. In short, the properties and uniformity of the final graphite products are greatly influenced by manufacturing and material variables.

ATJ graphite is a molded graphite with fine grain having good strength up to 5000°F. Its disadvan-

tages are that it is brittle, anisotropic, and shows large variations in a single piece. Its uses are for refractory structures, blocks, strips, and sleeves.

Specifications dealing with graphite normally address tensile strength, compressive strength, flexural strength, modulus of elasticity, thermal expansion, thermal conductivity, density, and electrical resistivity. The material data book developed for the NERVA PROGRAM, dated 30 June 1968, provides insight into the mechanical properties of ATJ Graphite (see Figures 11a and 11b).

Note that tensile strengths increase through temperatures of approximately 4600°F, but drop drastically beyond that point. A graph is shown (see Figure 11b) for compressive, shear, bearing, and flexural strengths for ATJ Graphite. Note that ultimate compressive strength continues to increase as temperatures are increased to 5000°F. However, ultimate flexural strengths begins to level off as temperatures approach 5000°F. Testing conducted by SRI for NASA indicates that compressive strength of ATJ 1792 starts to decline sharply after 5000°F.

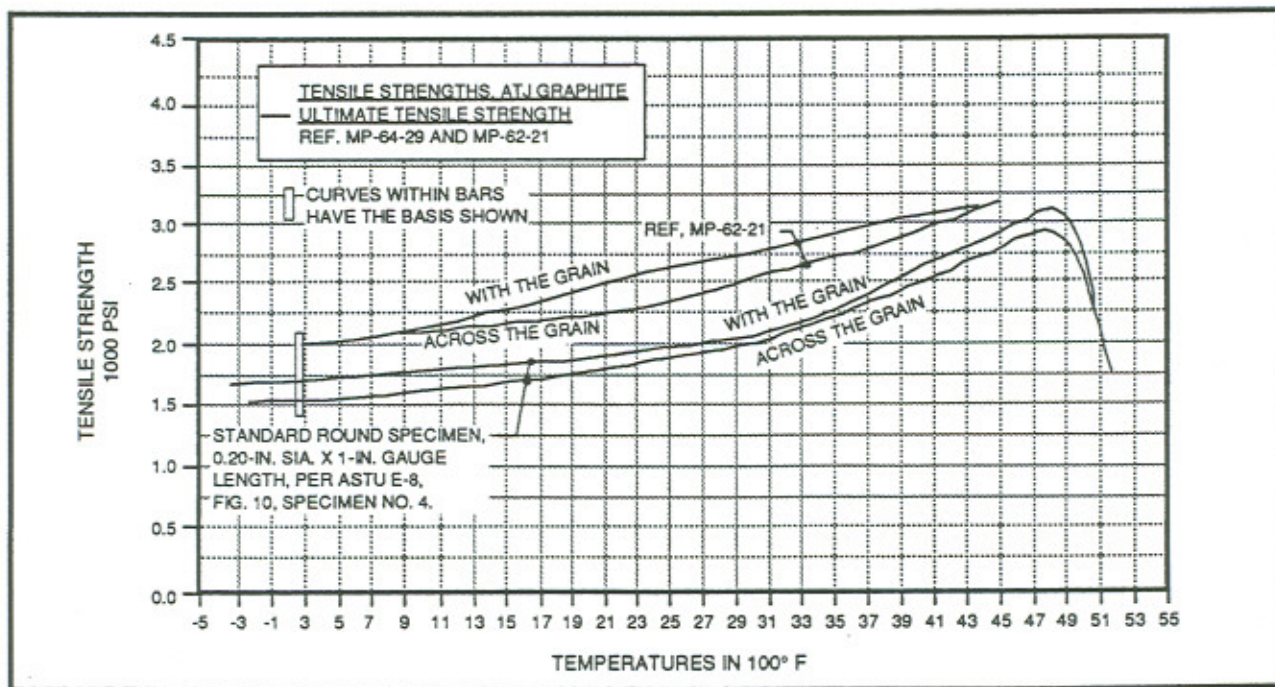

Figure 11a. Tensile Strengths of ATJ Graphite

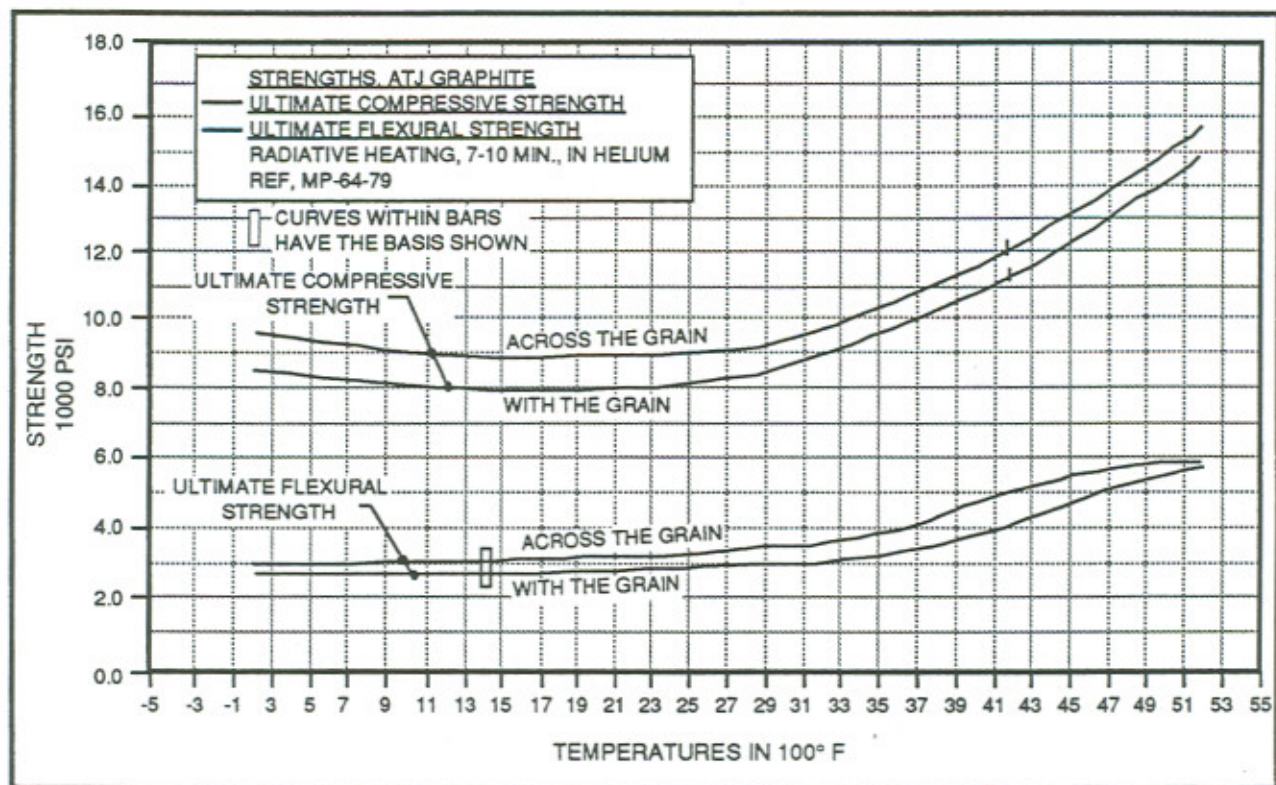

Figure 11b. Compressive, Shear, Bearing and Flexural Strength of ATJ Graphite

## 6. MISSILE INTERIM SPECIFICATION (MIS) FOR GRAPHITE

MIS-29147 is a MICOM Specification, developed in November 1979, for graphite, molded, for high temperature applications. The specification identifies the minimum and maximum values for apparent density, specific resistance, flexural strength and ash content. It does not address requirements relating to tensile strength, compressive strength, modulus of elasticity, or thermal expansion. Test specimens are to be taken from each block by obtaining one test slab and from that slab obtain a minimum of three test specimens both with and across the grain. MIS-29147 provided a suggested product — ATJ graphite as manufactured by the Union Carbide Corporation, Carbon Products Division, 270 Park Avenue, New York, New York.

MIS-29147 was cancelled on 13 October 1988. Future procurements were to be made IAW MIL-G-47316 (MI). There were no technical differences between MIS-29147 and MIL-G-47316 (MI). MIL-C-47316 (MI) does require a first article inspection, consisting of 10 units. Army TACMS Drawing Number 13287245 was not changed to reflect the cancellation of MIS-29147. Since the technical requirements were not changed it is possible that a decision was made within the Army TACMS Project Office not to incur the cost of changing the drawing.

MIS 29147 was replaced by MIS 40130 in April 1993. A summary of the revised chemical, electrical, and mechanical properties that were incorporated in MIS 40130 is listed in Table 5. All properties shown in Table 5 are for room temperature. The recommended graphite material is the grade of ATJ currently qualified or an approved equivalent.

TABLE 5. ADDITIONS TO MIS-40130

Property		Values	
		Minimum	Maximum
Density (g/cc)		1.73	1.79
Specific Resistance (ohms-cm x 10 <sup>-4</sup> )	With Grain	----	12.0
	Against Grain	----	13.5
Flexural Strength (psi)	With Grain	3500	----
	Across Grain	3500	----
Ash Content (%)		----	0.15
Compressive Strength (psi)	With Grain	8000	----
	Across Grain	8000	----
Modulus of Elasticity In Tension (psi)	With Grain	1.3x10 <sup>6</sup>	----
	Across Grain	1.1x10 <sup>6</sup>	----
Rockwell Hardness (L Scale)		60	----

## 7. TESTING BY SOUTHERN RESEARCH INSTITUTE

A contract was awarded to SRI to evaluate mechanical, thermal and physical properties of ATJ and Great Lakes bulk graphite materials.

### 7.1 Mechanical and Thermal Evaluations of ATJ and Great Lakes Graphite For Army TACMS

The two grades of bulk graphite evaluated for this effort were Union Carbide ATJ 1792 and Great Lakes Graphite H489 lot 51W52. The molded materials were compressed hydrostatically into 13" x 13" x 72" logs where the radial and circumferential directions correspond to the with-grain orientation and the across-grain orientation is axial. Three billets were removed from each log. The ATJ billets were taken from two different logs while the GL H489 billets were all removed from the same log.

The test matrix for this effort is shown in Table 6. It consists of across-grain and with-grain mechanical, thermal, and physical properties. Tests

were selected to correspond to key events in the materials.

The tensile properties: Ultimate strength, elastic modulus and strain-to-failure and stress-strain curves were obtained using a gas-bearing tensile machine.

The compressive properties were measured using a gas-bearing compressive facility.

The dimensions and weights were determined on the fully machined blanks to obtain bulk densities. The bulk density of each test specimen is included in appropriate mechanical tables from each billet.

The break and peak velocities were determined on the fully machined blanks in the test orientation. The inverse relationship between resistivity versus peak velocity showed the ATJ material has a higher resistivity and lower peak velocity while the GL material has a lower resistivity and higher peak velocity. All else being equal, this would indicate that the ATJ is a more graphite material while the GL H489 is more glassy.

TABLE 6. TEST MATRIX FOR ATJ AND GREAT LAKES GRAPHITE

SPECIMEN	RT	2000	4250	5000	NO. TEST
TN - AG (AX) TN - WG (CIR)	5 3	5	3	3	16 3
CM - AG (AX) CM - WG (CIR)	3 3		3	3 3	9 9
TE - AG (AX) TE - WG (CIR) TE - WG (RAD)	2 2 2	- - -	- - -	- - -	2 2 2
Density Radiography Sonic Velocity Electrical Resistivity Microscopy Billet NDC:					All Mechanical All Mechanical All Mechanical All Mechanical All Mechanical Slab Radiography Computed Tomography
<i>AG: Across Grain                      AX: Axial</i> <i>WG: With-Grain                      RAD: Radial</i> <i>CIR: Circumferencial</i>					

Computer Tomography (CT) scans were taken in the axial and radial orientations for both bulk graphite materials. CT scans were used to determine the materials density profile and to detect larger defects, greater than 20 mils. Samples of the scans, indicate the density variations of ATJ billets are greater than density variations of the GL billets. The strong defective zone in ATJ-2 has an indicated density of 1.52 gms/cc.

Radiographs were performed for all mechanical specimens. The radiographs typically showed greater density variations for the ATJ billets than for the GL billets. However, the radiographs also showed noticeable density variations within each billet with respect to nozzle location. These suggest that the location of the individual cored nozzle may also have an effect on the nozzle performance.

The bulk graphite materials were microscopically investigated using a Nikon Epiphot microscope. Samples from each billet were epoxy impregnated and polished. The porosity of the ATJ billets appeared to be greater in magnitude and

size than for the Great Lakes billets. The maximum pore size of the ATJ material was approximately 4 mils and approximately 2 mils for the GL material. Evaluations of the micrographs also showed the typical large defect size for the ATJ and GL materials to be approximately 16.5 mils and 9.5 mils, respectively. Micrographs of ATJ and Great Lakes carbon are shown in Figures 12 and 13.

Across-grain tensile evaluations were conducted for both ATJ and GL H489 bulk graphite at room temperature, 2000, 4250 and 5000 degrees F. With-grain tensile tests were conducted only at room temperature. Specimens were loaded at 10 Kpsi/min heated at 10 degrees F/sec where applicable.

The individual cross-grain tensile evaluations are tabulated in Tables 7 and 8. These evaluations show good replication for each material. The ATJ graphite yields greater material properties (strength and strain-to-failure) than the Great Lakes evaluations from RT to 5000 degrees F for both grain orientations.

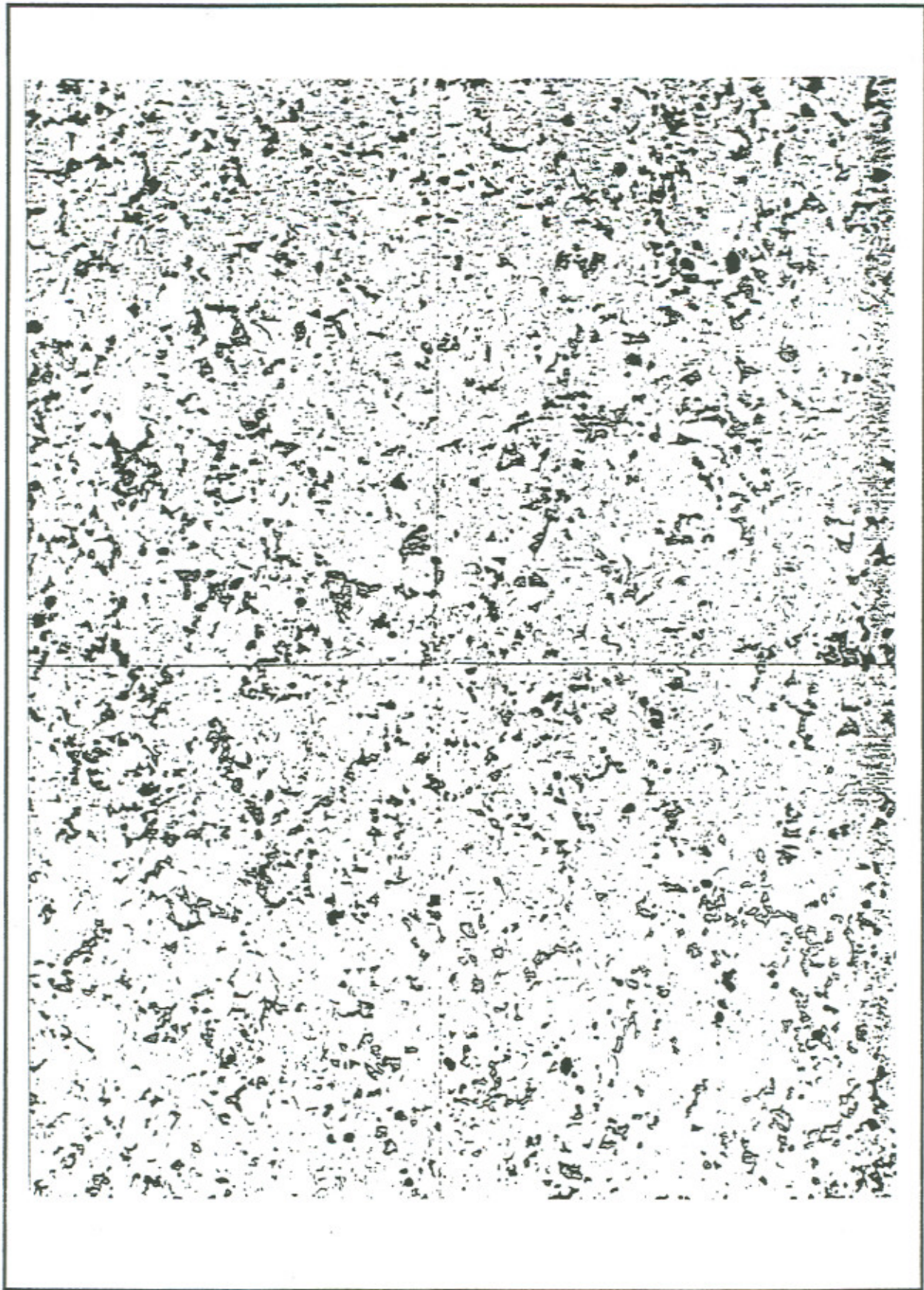

Figure 12. ATJ Micrograph in the With-Grain Orientation at 100x.

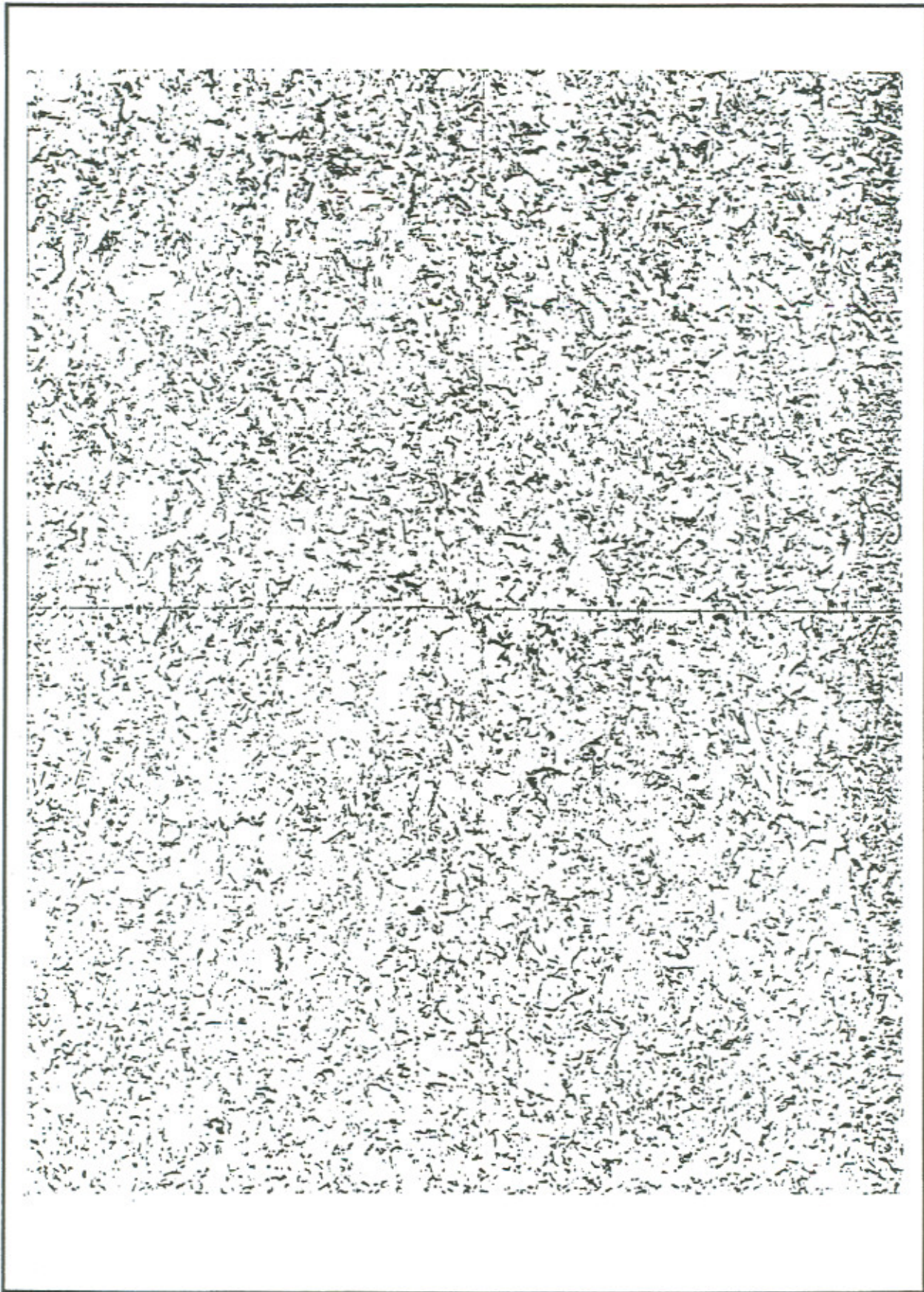

Figure 13. Great Lakes Graphite Micrograph in the With-Grain Orientation at 100x

**TABLE 7. TENSILE EVALUATIONS OF ATJ AND GREAT LAKES GRAPHITE MATERIALS TO 5000°F**

BILLET NUMBER	SPECIMEN TYPE	TEMP. (°F)	DENSITY (G/CC)	BREAK VELOCITY (IN/USEC)	PEAK VELOCITY (IN/USEC)	INT. ELASTIC MODULUS (MSI)	ULTIMATE STRAIN (IN/IN)	ULTIMATE STRESS (PSI)	FAILURE MODE LOCATION	REMARKS
ATJ-1	TN-AG-1	70	1.763	0.0929	0.092	1.62	0.0047	3800	0.49 B	
ATJ-1	TN-AG-5	70	1.746	0.0926	0.091	1.49	0.0044	3650	0.25 T	
ATJ-2	TN-AG-2	70	1.762	0.0942	0.093	1.39	0.0041	3505	0.85 B	
ATJ-2	TN-AG-6	70	1.758	0.0923	0.092	1.41	0.0049	3800	0.10 B	
ATJ-3	TN-AG-7	70	1.743	0.0296	0.091	1.47	0.0038	3343	0.15 B	
AVERAGE			1.754	0.0929	0.092	1.48	0.0044	3620		
AJT-1	TN-AG-2	2000	1.762	0.0924	0.091	1.86	0.0040	4498		
ATJ-1	TN-AG-6	2000	1.746	0.0917	0.091	1.87	0.0039	4257	0.30 B	
ATJ-2	TN-AG-3	2000	1.766	0.0952	0.095	1.76-1.95	0.0033	4404	0.55 B	
ATJ-2	TN-AG-7	2000	1.765	0.0952	0.095	1.46	0.0037	4440	0.30 T	
ATJ-3	TN-AG-2	2000	1.742	0.0912	0.091	1.58	0.0033	3800	0.45 B	
ATJ-3	TN-AG-6	2000	1.751	0.0921	0.091	1.58-1.99	0.0034	4068	0.50 T	
AVERAGE			1.755	0.0930	0.092	1.69	0.0036	4245		
ATJ-1	TN-AG-3	4250	1.759	0.0939	0.093	1.43	0.0230	6880	0.42 B	
ATJ-2	TN-AG-4	4250	1.757	0.0921	0.091	1.37	0.0150	6200	0.45 T	
ATJ-3	TN-AG-5	4250	1.750	0.0908	0.090	1.06	0.0254	6526	0.45 T	
AVERAGE			1.755	0.0923	0.091	1.29	0.0211	6535		
ATJ-1	TN-AG-4	5000	1.747	0.0923	0.091	0.56	>.0612	6306	0.35 B	Strain Scale Not Reset
ATJ-2	TN-AG-5	5000	1.751	0.0916	0.091	0.51	>.0587	5798	0.22 B	Lost Flags
ATJ-3	TN-AG-4	5000	1.747	0.0895	0.089	0.63	>.0632	5300	0.60 B	Strain Scale Not Reset
AVERAGE			1.748	0.0911	0.090	0.57	#DIV/0!	5801		
GL-1	TN-AG-1	70	1.722	0.0882	0.087	1.13-1.30	0.0027	2260	0.25 B	
GL-2	TN-AG-5	70	1.739	0.0888	0.087	1.21-1.36	0.0032	2462	0.45 B	
GL-2	TN-AG-7	70	1.740	0.0910	0.090	1.22	0.0028	2452	0.45 T	
GL-3	TN-AG-1	70	1.731	0.0875	0.086	1.13-1.35	0.0028	2400	0.55 B	
GL-3	TN-AG-5	70	1.733	0.0889	0.088	1.23	0.0033	2640	0.25 B	
AVERAGE			1.733	0.0889	0.088	1.23	0.0030	2443		
GL-1	TN-AG-2	2000	1.726	0.0894	0.087	1.28	0.0028	3000	0.45 B	
GL-1	TN-AG-7	2000	1.731	0.0863	0.085	1.34	0.0031	3122	0.45 B	
GL-2	TN-AG-2	2000	1.747	0.0908	0.089	1.58	0.0030	3450	0.45 T	
GL-3	TN-AG-2	2000	1.733	0.0877	0.086	1.56	0.0026	2959	0.40 B	
GL-3	TN-AG-7	2000	1.735	0.0891	0.088	1.25	0.0031	3353	0.20 T	
AVERAGE			1.734	0.0887	0.087	1.40	0.0029	3177		
GL-1	TN-AG-5	4250	1.731	0.0858	0.084	0.88	0.144	4730		
GL-2	TN-AG-3	4250	1.746	0.0900	0.090	1.00	0.0171	5475	0.10 T	
GL-3	TN-AG-3	4250	1.732	0.0878	0.086	0.99	0.0094	4313	0.20 T	
AVERAGE			1.737	0.0882	0.087	0.96	0.0136	4839		
GL-1	TN-AG-4	5000	1.731	0.0861	0.085	0.46	0.0522	3850	0.46 T	
GL-2	TN-AG-4	5000	1.742	0.0901	0.089	0.45	0.0580	4512	0.55 T	
GL-3	TN-AG-4	5000	1.729	0.0882	0.086	0.69	0.0516	4296	0.22 B	
AVERAGE			1.734	0.0881	0.087	0.53	0.0539	4219		

**TABLE 8. TENSILE EVALUATIONS OF ATJ AND GREAT LAKES GRAPHITE MATERIALS AT ROOM TEMPERATURE**

BILLET NUMBER	SPECIMEN TYPE	TEMP. (°F)	DENSITY (G/CC)	BREAK VELOCITY (IN/USEC)	PEAK VELOCITY (IN/USEC)	INT. ELASTIC MODULUS (MSI)	ULTIMATE STRAIN (IN/IN)	ULTIMATE STRESS (PSI)	FAILURE MODE LOCATION	REMARKS
ATJ-1	TN-WG-1	70	1.759	0.1017	0.101	1.39	0.0044	4466	0.42 B	
AJT-2	TN-WG-1	70	1.769	0.1025	0.102	2.05	0.0042	4514		
ATJ-3	TN-WG-1	70	1.738	0.0971	0.096	1.44	0.0044	3998	0.35 T	
AVERAGE			1.755	0.1004	0.100	1.63	0.0043	4326		
GL-1	TN-WG-1	70	1.728	0.0940	0.093	1.67	0.0032	3059	0.55 B	
GL-2	TN-WG-1	70	1.745	0.9067	0.095	1.60	0.0030	3010	0.12 B	
GL-3	TN-WG-1	70	1.733	0.0955	0.094	1.61	0.0035	3116	0.20 T	
AVERAGE			1.735	0.0954	0.094	1.63	0.0032	3062		

The across-grain and with-grain tensile properties of the ATJ and H489 materials are compared to historical Graphite and Graphnol materials in Table 9. Historical comparisons show that ATJ billets to yield lower than historical material properties. However, the ATJ still has tensile properties greater than the H489 billets.

Failure analysis of the tensile specimens showed random fracture surfaces with the failure initiation side along the specimen's outside diameter. Failure location is recorded in Tables 7 and 8 with respect to the specimen's gage centerline. These data show a balanced number of top and bottom failures indicating proper alignments and loading.

TABLE 9. SUMMARY OF TENSILE STRESS-STRAIN DATA FOR THE AVERAGE CURVES OF GRAPHITE AND GRAPHNOL MATERIAL

Material	Property	Orientation	Temp (°F)	Stress Rate (psi/min)	Initial Modulus (Msi)	Poisson's Ratio	Ultimate Stress (psi)	Ultimate Strain (in./in.)	Bilinear Fits to Stress-Strain Curves				
									Primary Modulus (Msi)	Secondary Modulus (Msi)	Yield Strain (in./in.)	Yield Stress (psi)	Strain Value That Fit is Extended to (in./in.)
GREAT LAKES ATJ	Tension	Across Grain	70	10000	1.23	-	2443	0.0030	-	-	-	-	-
ATJ (TS 1792)	Tension	Across Grain	70	10000	1.48	-	3620	0.0044	-	-	-	-	-
ATJ-S (WS)	Tension	Across Grain	70	-	1.35	0.12	3838	0.0040	-	-	-	-	-
GRAPHNOL N3M	Tension	Across Grain	70*	10000	1.13	-	-	-	0.5930	0.0019	2177	-	-
GRAPHNOL N3M	Tension	Across Grain	70*	10000	1.24	-	5792	0.0094	1.1520	0.4290	0.0027	3086	0.01
GREAT LAKES ATJ	Tension	Across Grain	2000	10000	1.40	-	3177	0.0029	-	-	-	-	-
ATJ (TS 1792)	Tension	Across Grain	2000	10000	1.69	-	4245	0.0036	-	-	-	-	-
ATJ-S (WS)	Tension	Across Grain	2000	-	1.44	-	4777	0.0039	-	-	-	-	-
ATJ-S (WS)	Tension	Across Grain	2000	10000	1.23	-	-	-	0.6290	0.0029	3526	-	-
GRAPHNOL N3M	Tension	Across Grain	2000	10000	1.45	-	6550	0.0088	1.3210	0.3880	0.0035	4557	0.01
ATJ (TS 1792)	Tension	Across Grain	4000	-	1.17	-	6720	0.0090	-	-	-	-	-
ATJ-S (WS)	Tension	Across Grain	4000	10000	1.13	-	-	-	0.2990	0.0039	4360	-	-
GREAT LAKES ATJ	Tension	Across Grain	4250	10000	0.96	-	4839	0.0136	-	-	-	-	-
ATJ	Tension	Across Grain	4250	10000	1.29	-	6536	0.0211	-	-	-	-	-
ATJ (TS 1792)	Tension	Across Grain	4500	-	0.86	-	7208	0.0290	-	-	-	-	-
GRAPHNOL N3M	Tension	Across Grain	4500	10000	1.20	-	9195	0.0430	1.1630	0.3100	0.0033	3890	0.01
GREAT LAKES ATJ	Tension	Across Grain	5000	10000	0.53	-	4219	0.0539	-	-	-	-	-
ATJ (TS 1792)	Tension	Across Grain	5000	10000	0.57	-	5801	>0.0610	-	-	-	-	-
ATJ (TS 1792)	Tension	Across Grain	5000	-	0.44	-	6597	-	-	-	-	-	-
GREAT LAKES ATJ	Tension	With Grain	70	10000	1.63	-	3062	0.0032	-	-	-	-	-
ATJ (TS 1792)	Tension	With Grain	70	10000	1.63	-	4326	0.0043	-	-	-	-	-
ATJ-S (WS)	Tension	With Grain	70	-	1.43	0.12	4438	0.0044	-	-	-	-	-
ATJ-S (WS)	Tension	With Grain	70	10000	1.69	-	-	-	0.9350	0.0015	2525	-	-
GRAPHNOL N3M	Tension	With Grain	70**	10000	1.26	-	6419	0.0098	1.2110	0.4700	0.0028	3422	0.01

\*Average across-grain Poisson's ratio = 0.006

\*\*Average with-grain Poisson's ratio = 0.140

Investigations also showed no evidence of anomalies in the fractured surfaces.

Across-grain compressive evaluations were conducted for both ATJ and GL H489 bulk graphite at room temperature, 4250 and 5000 degrees F. With-grain samples were tested only at room temperature. Specimens were loaded at 10 Kpsi/min and heated at 10 degrees F/sec where applicable.

The individual compressive across-grain and with-grain evaluations are tabulated in Table 10. These evaluations showed good replication for each material. The ATJ graphite yields greater material properties than the GL evaluations from RT to 5000 degrees F for both grain orientations.

The across-grain and with-grain ATJ and H489 materials are compared to historical Graphite and Graphnol materials in Table 11. Historical materials show the ATJ billets to yield lower than historical material properties. Both materials have very high compressive strains to failure at 4250 and 5000 degrees F and were only tested to an axial deformation of 150 mils/inch. This limit was selected to yield the most accurate stress-

strain in the elastic region of the curve. Above the selected limit, the calibrated strain gages yield nonlinear strains.

Failure analysis of the compressive specimens showed the principal mode of failure to be shear along a 45 degree plane. The elevated temperature specimens did not fail catastrophically but yielded in "plastic" deformation in the axial direction resulting in circumferential expansion.

Thermal expansion evaluations were conducted for both ATJ and GL H489 bulk graphite from room temperature to 5000 degrees F. Across-grain (axial) and with-grain (radial and circumferential) thermal specimens were evaluated in the quartz test facility to 1800 degrees F and in the graphite test facility to 5000 degrees F.

The individual thermal expansion across-grain and with-grain evaluations are shown in Figures 14 and 15. These evaluations show good replication and good agreement between the two techniques. The ATJ graphite has lower thermal expansions than the H489 evaluations from RT to 5000 degrees F for both grain orientations.

**TABLE 10. COMPRESSIVE EVALUATIONS OF ATJ AND GREAT LAKES GRAPHITE MATERIALS TO 5000°F**

Material ID	Specimen ID	Temp. (°F)	r (gm/cc)	Break Velocity (in/usec)	Peak Velocity (in/usec)	Sonic Modulus (msl)	E (msl)	s (psi)	e (in/in)	Comments
AJT-1	CM-WG-1	RT	1.7597	0.1016	0.1003	1.7075	1.25	10060	0.0300	
AJT-2	CM-WG-1	RT	1.7686	0.1025	0.1012	1.7466	1.16	10580	0.0350	
AJT-3	CM-WG-1	RT	1.7379	0.0970	0.0958	1.5371	1.17	8780	0.0258	
AVERAGE			1.7554	0.1004	0.0991	1.6637	1.19	9807	0.0303	
GL-1	CM-WG-1	RT	1.7264	0.0938	0.0923	1.4278	1.10	8171	0.0240	
GL-2	CM-WG-1	RT	1.7451	0.0959	0.0943	1.5086	1.22	8660	0.0253	
GL-3	CM-WG-1	RT	1.7345	0.0949	0.0933	1.4864	1.09	8060	0.0207	
AVERAGE			1.7353	0.0949	0.0933	1.4683	1.14	8297	0.0233	
ATJ-1	CM-AG-1	RT	1.7505	0.0923	0.0912	1.4018	1.00	10150	0.0370	
ATJ-1	CM-AG-4	RT	1.7474	0.0910	0.0899	1.3602	1.01	9400	0.0335	
ATJ-2	CM-AG-3	RT	1.7685	0.0950	0.0939	1.5003	1.09	10560	0.0400	
AVERAGE			1.7555	0.0928	0.0917	1.4208	1.03	10037	0.0368	
ATJ-1	CM-AG-2	4250	1.7549	0.0934	0.0919	1.4390	1.25	>12560	>0.1000	
ATJ-2	CM-AG-1	4250	1.7705	0.0961	0.0947	1.5370	0.92	>11760	>0.1000	
ATJ-2	CM-AG-4	4250	1.7575	0.0925	0.0915	1.4135	0.93	>11780	>0.1000	
AVERAGE			1.7610	0.0940	0.0927	1.4632	1.03	>12033	>0.1000	
ATJ-1	CM-AG-3	5000	1.7519	0.0926	0.0916	1.4121	0.69	>7820	>0.1000	
ATJ-2	CM-AG-2	5000	1.7727	0.0957	0.0946	1.5261	0.68	>8250	>0.1000	
ATJ-2	CM-AG-1	5000	1.7450	0.0911	0.0899	1.3613	0.67	>8000	>0.1000	
AVERAGE			1.7565	0.0931	0.0920	1.4332	0.68	>8023	>0.1000	
GL-1	CM-AG-1	RT	1.7307	0.0894	0.0876	1.3002	1.00	7280	0.0176	
GL-1	CM-AG-4	RT	1.7333	0.0870	0.0855	1.2332	0.97	8232	0.0276	
GL-2	CM-AG-3	RT	1.7444	0.0896	0.0879	1.3164	1.01	7832	0.0206	
AVERAGE			1.7361	0.0887	0.0870	1.2833	0.99	7781	0.0219	
GL-1	CM-AG-2	4250	1.7311	0.0871	0.0854	1.2345	1.04	>10840	>0.1000	
GL-2	CM-AG-1	4250	1.7433	0.0914	0.0893	1.3690	1.00	>10749	>0.1000	
GL-3	CM-AG-1	4250	1.7339	0.0880	0.0855	1.2622	0.74	>9409	>0.1000	
AVERAGE			1.7361	0.0888	0.0867	1.2885	0.93	>10333	>0.1000	
GL-1	CM-AG-3	5000	1.7311	0.0857	0.0840	1.1951	0.40	>6100	>0.1000	
GL-2	CM-AG-2	5000	1.7458	0.0896	0.0878	1.3175	0.53	>6873	>0.1000	
GL-3	CM-AG-2	5000	1.7346	0.0907	0.0888	1.3413	0.53	>6320	>0.1000	
AVERAGE			1.7372	0.0887	0.0869	1.2846	0.49	>6431	>0.1000	

**TABLE 11. SUMMARY OF COMPRESSIVE STRESS-STRAIN DATA FOR THE AVERAGE CURVES OF GRAPHITE AND GRAPHNOL MATERIAL**

Material	Temp (°F)	Grain Direction	Stress Rate (psi/min)	Primary Elastic Modulus (Msi)	Stress At 0.2% Offset (psi)	Stress At 2% Strain (psi)	Stress at Ultimate (psi)	Strain at Ultimate (in./in.)	Bilinear Fits to Stress-Strain Curves					
									Poisson's Ratio	Primary Modulus (E) (Msi)	Secondary Modulus (II) (Msi)	Yield Strain (S) (in./in.)	Yield Stress (Y) (psi)	Fit Extended to Percent Strain %
GREAT LAKES ATJ	70	Across Grain	10000	0.99	1952	4330	7781	0.0219	-	-	-	-	-	-
ATJ (TS1792)	70	Across Grain	10000	1.03	2114.5	4625	10037	0.0368	-	-	-	-	-	-
AJT-S (WS)	70	Across Grain	-	1.33	-	-	13245	0.0504	-	-	-	-	-	-
GRAPHNOL N3M	70	Across Grain	10000	1.06	-	-	-	-	-	1.064	0.453	0.0027	2915	-
GRAPHNOL N3M	70	Across Grain	10000	1.18	6170	9659	14410	-	0.132	1.027	0.529	0.0033	3994	1.0
ATJ (TS1792)	4000	Across Grain	10000	1.71	-	-	25108	>0.1320	-	-	-	-	-	-
ATJ-S (WS)	4000	Across Grain	10000	1.28	-	-	-	-	-	1.283	0.44	0.0037	4723	-
GREAT LAKES ATJ	4250	Across Grain	10000	0.93	3300	5116	>10332	>0.1000	-	-	-	-	-	-
ATJ	4250	Across Grain	10000	1.03	3733	6297	>12033	>0.1000	-	-	-	-	-	-
ATJ (TS1792)	4500	Across Grain	-	1.34	-	-	>22575	>0.2403	-	-	-	-	-	-
ATJ-S (WS)	4500	Across Grain	10000	1.20	-	-	-	-	-	1.198	0.463	0.0032	3860	-
GRAPHNOL N3M	4500	Across Grain	10000	1.67	6136	7840	-	-	-	1.632	0.330	0.0031	5118	1.0
GREAT LAKES ATJ	5000	Across Grain	10000	0.49	1766	3249	>6431	>0.1000	-	-	-	-	-	-
ATJ	5000	Across Grain	10000	0.68	2417	4133	>8023	>0.1000	-	-	-	-	-	-
ATJ (TS1792)	5000	Across Grain	-	0.70	-	-	8625	-	-	-	-	-	-	-
ATJ-S (WS)	5000	Across Grain	10000	0.98	-	-	-	-	-	0.981	0.363	0.0028	2765	-
GRAPHNOL N3M	5000	Across Grain	10000	0.68	4068	5600	-	-	-	0.849	0.296	0.0029	2485	1.0
GREAT LAKES ATJ	70	With Grain	10000	1.14	2316	4832	8297	0.0233	-	-	-	-	-	-
ATJ	70	With Grain	10000	1.19	2550	5266	9807	0.0303	-	-	-	-	-	-
ATJ (TS1792)	70	With Grain	-	1.37	-	-	12935	0.0344	-	-	-	-	-	-
ATJ-2 (WS)	70	With Grain	10000	1.39	-	-	-	-	-	1.386	0.0378	0.0028	3854	-
GRAPHNOL N3M	70	With Grain	10000	1.25	6445	10005	14175	-	0.147	1.208	0.516	0.0038	4622	1.0

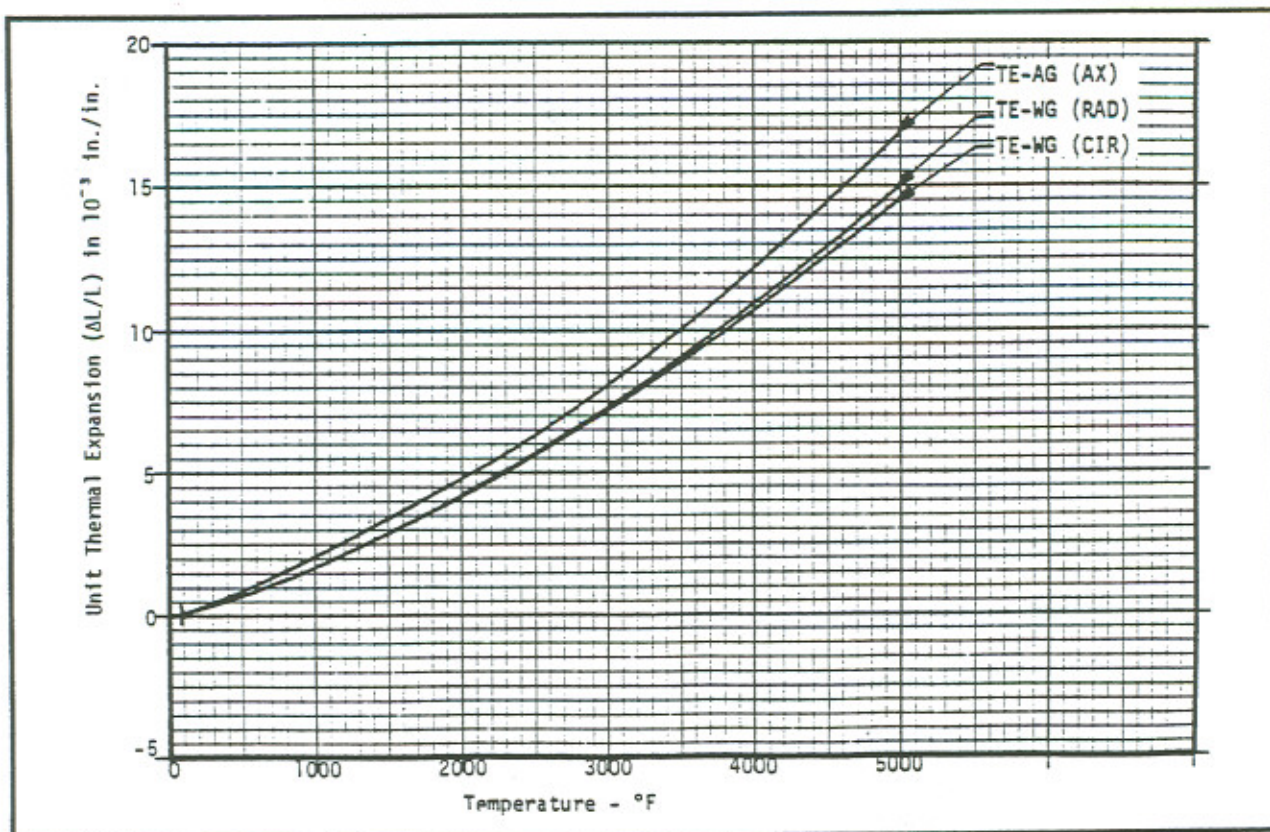

Figure 14. Across and With-Grain Thermal Expansion of ATJ Graphite to 5000°F (ATJ-3)

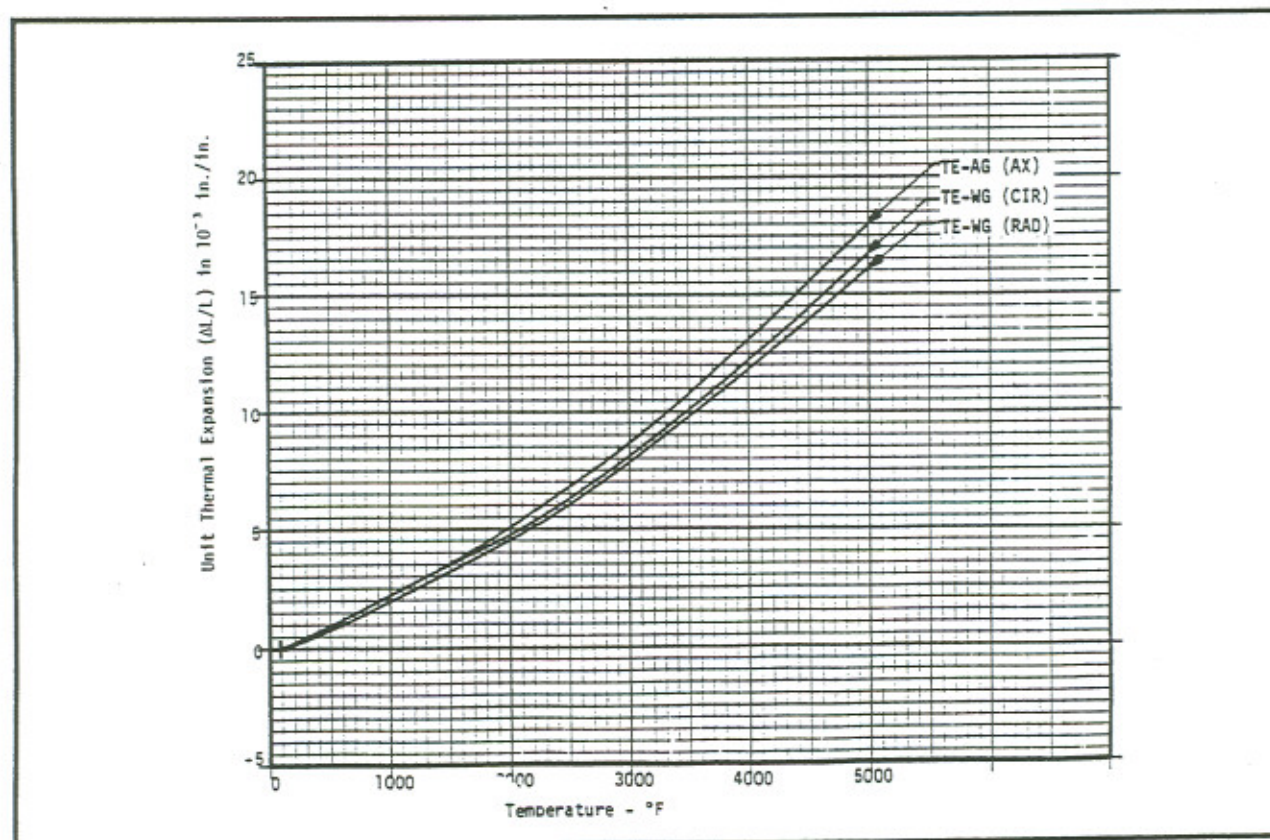

Figure 15. Across and With-Grain Thermal Expansion of Great Lakes Graphite to 5000°F (GL-3)

The across-grain and with-grain ATJ and H489 materials are compared to historical ATJ Graphite and Graphnol materials in Figures 16 and 17. Historical comparisons show the ATJ material to

have greater thermal expansions than historical material. However, the ATJ material still has expansions lower than the H489 material.

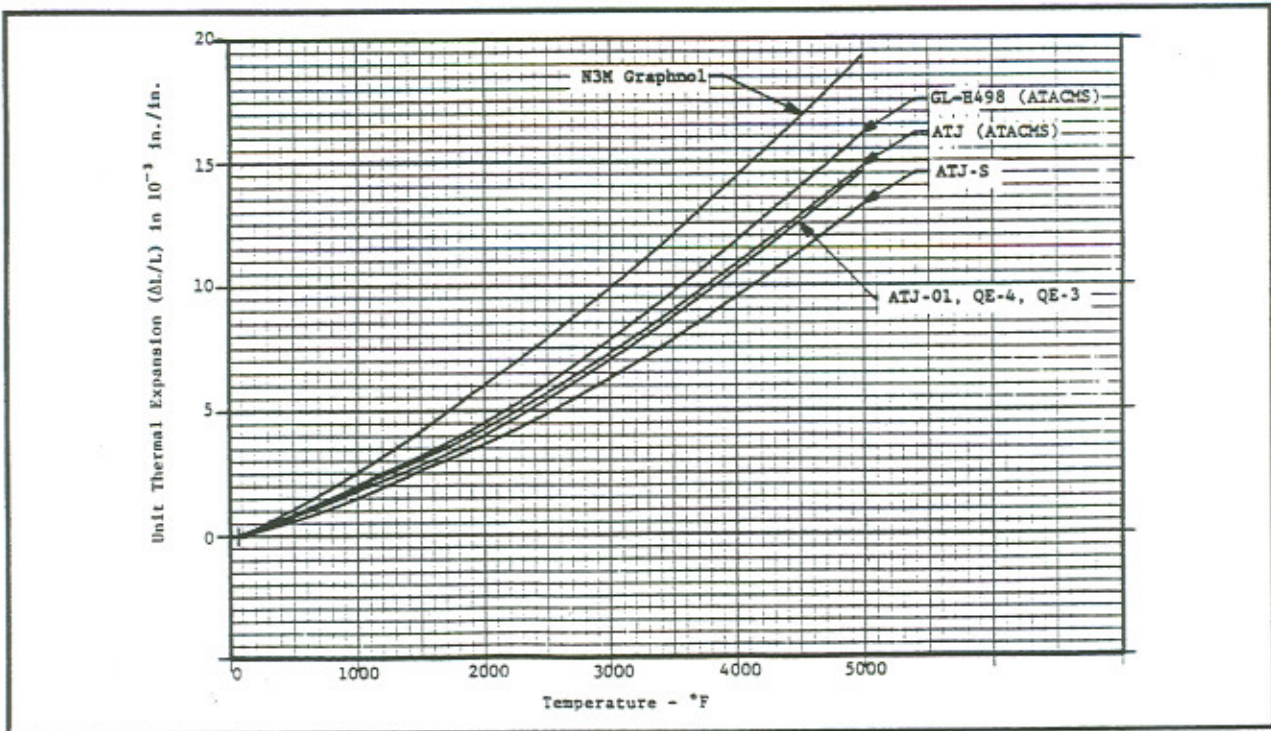

Figure 16. With-Grain Thermal Expansion Comparison of ATJ and GL Graphite to Historical Graphite and Graphnol

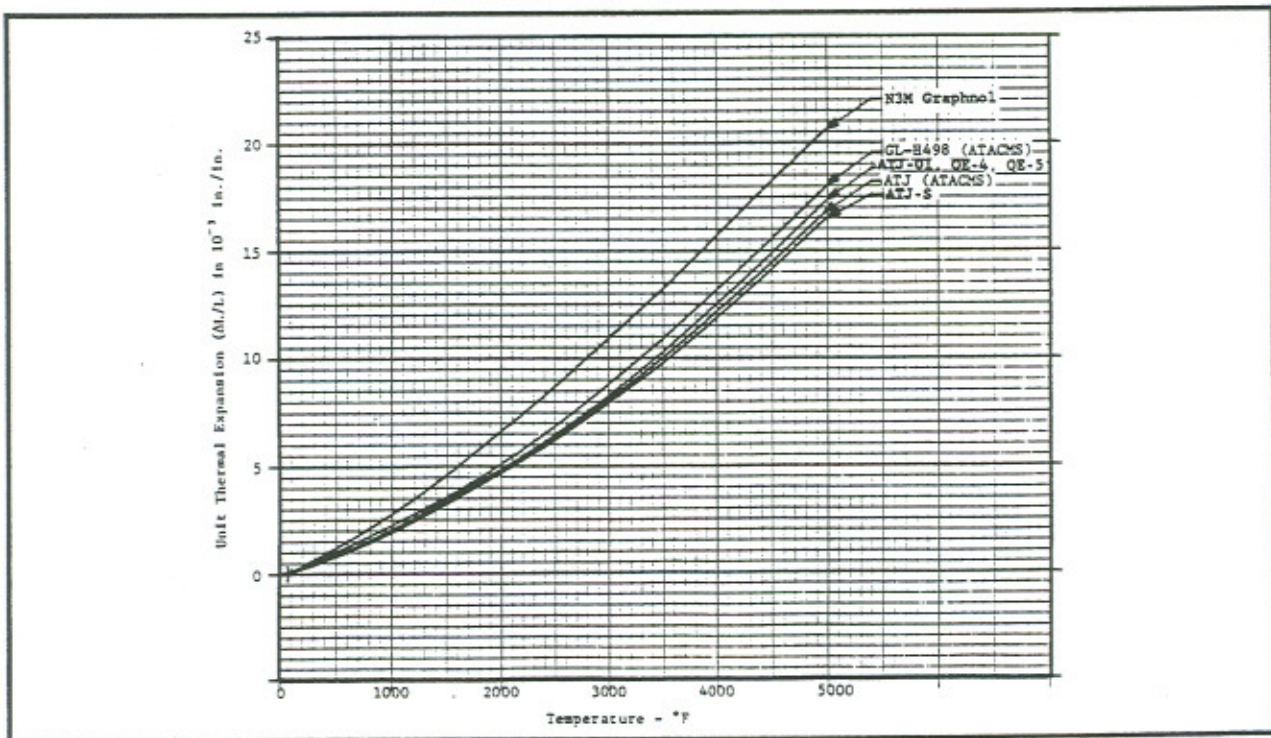

Figure 17. Across-Grain Thermal Expansion Comparison of ATJ and GL Graphite to Historical Graphite and Graphnol

## 7.2 Mechanical and Thermal Evaluations of Great Lakes H489 Lot 14Y36/15Y3 Graphite for ATACMS

The bulk graphite evaluated for this effort was Great Lakes Graphite H489 Lot 14Y36/15Y3. The material was compressed hydrostatically into 13" x 13" x 72" logs where the radial and circumferential directions correspond to the with-grain orientation while the across-grain orientation is axial. The test billet was removed from one of several logs. Locations of the individual billets within the logs were not recorded.

The test matrix for this effort is shown in Table 12. It consists of compression in across-grain and with-grain orientations and thermal properties in the with-grain orientation only. Test temperatures were selected to correspond to key events in the materials.

The procedures for this effort are the same as the procedures listed under the previous topic entitled "Mechanical and Thermal Evaluations of ATJ and Great Lakes Graphite for ATACMS".

Details of this evaluation and the results obtained from the evaluation are contained in Southern Research Institute report SRI-MME-92-1072-7775

titled "Mechanical and Thermal Evaluations of Great Lakes H489 LOT 14Y36/15Y3 Graphite for ATACMS", dated December 1992.

## 7.3 Summary

The Union Carbide ATJ 1972 has superior thermostructural properties compared to the Great Lakes Graphite H489 lot 51W52 despite the fact that this is a poor grade of ATJ. The H489 is reported to be of typical quality compared to historical materials. Both materials have very high compressive strains to failure at 4250 and 5000 deg F. These strains to failure exceeded the strains that are possible in a pure deformation loaded environment. "Typical" defect free ATJ probably has acceptable properties based on pure thermal/stress loading only. Superior properties are available in other products, but these are expensive.

The Great Lakes H489 Lot 14Y36/15Y3 Graphite has slightly stiffer compressive properties compared to the Great Lakes H489 Lot 51W52 Graphite material. However, the ATJ (ATACMS) material still has greater compressive stiffness and strength compared to the Great Lakes materials. All materials have very high compressive strains to failure at 4250, 4500, and 5000°F. These strains to failures far exceed the strains that are

TABLE 12. TEST MATRIX FOR GREAT LAKES H489 LOT 14Y36/15Y3 GRAPHITE MATERIAL

SPECIMEN	RT	2000	4250	4500	5000	NO. TEST
CM - AG (AX) CM - WG (CIR)	2 2		2	2	3	9 2
TE - WG (CIR)	(1)	(2)	-	-	-	2
Density Radiography Sonic Velocity Electrical Restivity Billet NDC:						All Mechanical All Mechanical All Mechanical All Mechanical Computed Tomography
AG: Across-Grain AX: Axial WG: With-Grain RAD: Radial CIR: Circumferential						

possible in a pure deformation loaded environment.

Thermal expansion evaluations show this lot of GL H489 material is equivalent to the historical GL H489 Lot 52W52 material. However, the ATJ material still has expansions lower than the GL H489 materials.

## 8. SUMMARY OF FINDINGS

A comprehensive process and inspection review of the nozzle failure was made on the adhesives, O-rings, igniter closure, graphite inserts, throat insulator, exit cone, and throat assemblies. No abnormalities were surfaced. The graphite throat insert (GLC), however, had significantly lower mechanical properties than graphite used in FSD. Samples were taken from manufactured inserts and tests confirmed this difference.

The root cause of the flight failures was compressive failure of the graphite insert. The corrective actions that have been taken are: (1) discontinued use of GLC inserts, (2) current motors are being delivered with UC motors, (3) 100 percent X-ray of throat inserts, (4) flexural and comprehensive strength measurements have been made on UC and GLC motors, and (5) motor rework program is in process that will replace all of the suspect GLC graphite inserts.

Propulsion Directorate did not conduct independent analyses in the early stages of the Research and Development Program (1986-1988). After the nozzle failure, Propulsion Directorate (RDEC) was tasked to conduct an independent thermostructural analysis to define the state of stress and safety factors in the throat insert. Propulsion Directorates of RDEC feel that they should be tasked to provide an independent assessment of the work being performed by the Prime Contractor and their subcontractor early in a program.

MIS-29147 is a specification that covered one type of molded graphite that was developed for the Chaparral Missile Program. Conversations

with various individuals associated with the Army TACMS program did not provide any indication that a detailed analysis was performed prior to the selection of this specification for its applicability to the Army TACMS program. Properties of graphite are known to differ widely, not only between different grades, but between different lots. Additional variations in properties may be found between locations and orientations within a single block. Vendor specification sheets dealing with graphite normally address its range of properties (tensile strengths, compressive strength, flexural strength, modulus of elasticity, thermal expansion, thermal conductivity, density, and electrical resistivity). MIS-29147 only addressed apparent density, specific resistance, flexural strength, and ash content. It did provide a suggested source as being ATJ graphite as manufactured by the UC.

Interviews with MICOM personnel indicated the switch from UC ATJ graphite inserts to GLC inserts was done to create a savings of \$14.75 per motor. Additionally, it was stated that motor firing tests were not performed on GLC 489 before it was accepted for production motors. Any static testing at ARC was performed after FCA and PCA of the SRM.

Numerous individuals confirmed that SRM nozzles are always one of the most critical parts of a missile. For example, an ambient temperature static test on a Army TACMS SRM was performed at Redstone Arsenal on 12 October 1988. An inspection of the motor exit cone after completion of the static test revealed a hot gas burn through on the exit cone wall. An investigation concluded that the primary cause for the degraded exit cone performance was variations in the raw material properties and molding processes. Subsequent evaluations were conducted, and materials and processes were changed to correct the problem.

Mr. Charlie Borum, former Chief of Configuration Management in the Pershing Project Office provided an interesting insight into a SRM nozzle

failure on the Pershing Missile System relating to the use of graphite. The Pershing rocket motor manufacturer decided to change to a better grade of graphite. Detailed thermostructural analysis was assumed to be unnecessary. Pershing experienced a motor burnthrough. Results of the Root Cause Investigation revealed that the problem was a change in the Modulus of Elasticity of the newer/improved graphite which caused a buckling that provided space for the burnthrough.

After extensive analysis and testing by both the Government and Contractors, MIS-40130, Missile Command Specification Material Specification for Graphite, Isostatically Molded was accepted on 27 April 1993 for use on the Army TACMS Program. This specification changes/adds chemical, electrical, and mechanical properties (Bulk Density, Electrical Resistivity, Flexural Strength, Ash Content, Compressive Strength, Rockwell Hardness, and Elastic Modulus) to coincide with the requirements of the Army TACMS Missile. Besides aligning the technical requirements, MIS-40130 eliminates the administrative loopholes found in the old specification. For example, any significant change in methods or process of manufacturing, manufacturing source, or relocation of a manufacturing or process facility of a qualified product shall require qualification as a new product. In addition, the test procedures and administrative procedures such as identification and marking, block serialization, and workmanship have been modified to eliminate problems identified during the failure investigation. A copy of MIS-40130 is attached as Appendix C.

## **9. CONCLUSIONS**

There were two major causes of the Army TACMS flight nozzle failure. The major causes were:

1. MIS-29147 was a poorly written specification that was produced for the Chaparral Missile System. Technically, the specification was incomplete in that it principally addressed flexural strength. Apparently, no one involved in the specification writing process understood the com-

plexities of graphite nor the Army TACMS SRM characteristics. For example, the suggested source for graphite in MIS-29147 was UC ATJ graphite. The properties of UC ATJ graphite far exceeded the specification requirements. The properties of GLC Graphite H-489 more closely resemble the requirements of the specification. However, the variability between lots raises the issue of safety margins.

2. The contractor simply did not do an adequate analysis before switching to another (cheaper) graphite.

RDEC should be tasked to perform independent assessments of the work being performed by the prime contractor and subcontractors where critical parts/processes are involved such as graphite inserts, adhesives, etc. However, the conclusion drawn by the authors of this report is that their involvement in the program might not have prevented the 4 September 1991 flight failure. The rationale for making this statement is (1) RDEC was responsible for writing the MIS and would have provided support to the project office based on the wording of the specification, (2) GLC graphite met the specification and resulted in a cost savings, (3) drawing did not require LTV to submit an Engineering Change Proposal (ECP) in order to change graphite vendors as long as the graphite meets specifications, and (4) RDEC did not demonstrate a good understanding of graphite.

The inherent properties of graphite suggest that multiple samples from several locations within a graphite block are required for acceptance testing. (MIS-29147 required three specimens be tested from one slab out of a block and that selection criteria be centered more around the mean than the extremes).

Since the properties of graphite are known to differ widely, not only between different grades, but between different lots, it is imperative that testing and x-raying of samples be given high priority.

Specifications should be periodically reviewed to determine if they are still applicable to the specific program based on new technological breakthroughs, changes in mission requirements, and incorporation of new standards.

MIS-40130, Material Specification for Graphite, Isostatically Molded aligns the graphite technical requirements with the requirements of the Army TACMS Rocket Motor Nozzle, implements a more comprehensive test procedure for identification and elimination of use of marginal graphite, and closes the administrative loopholes for changing vendors to save a few dollars. The latter is accomplished by requiring qualification as a new product any change in methods of manufacturing, manufacturing source, or relocation of a manufacturing or process facility.

## **10. LESSONS LEARNED**

---

(1) When dealing with critical components/materials contractors should not arbitrarily change to a new material after completing the design phase without proper review by responsible engineers even if existing specifications are written in such a manner to allow substitution. Finite element analysis and material testing are a must to verify material requirements.

During FSD the adequacy of the specification should be determined (i.e., ensure that the specification matches the requirement).

(2) RDEC should be tasked to provide independent assessments of work being performed by the prime contractor and subcontractors. Highly competent technical personnel should be involved in monitoring, analysis, and observation of contractor testing/decisions regarding selection of highly critical missile components/materials. However, if they are to perform this function they must be responsive to Project Office schedules.

(3) Government drawings, where highly critical parts/processes are involved such as the graphite insert, should either be source controlled or the specification should require requalification as a new product due to any changes of manufacturing, manufacturing source, or relocation of a manufacturing or process facility. Government should demand the prime contractor conduct very detailed analysis to justify the change and highly competent technical personnel should conduct an independent analysis. Minor cost savings must not be the overriding factor in selection of critical manufacturing process components.

(4) Configuration Management must provide material lot traceability by vendor serialization or as a minimum, material lot control and lot traceability.

(5) Graphite is a complex material. New/different specification is required for each weapon system application.

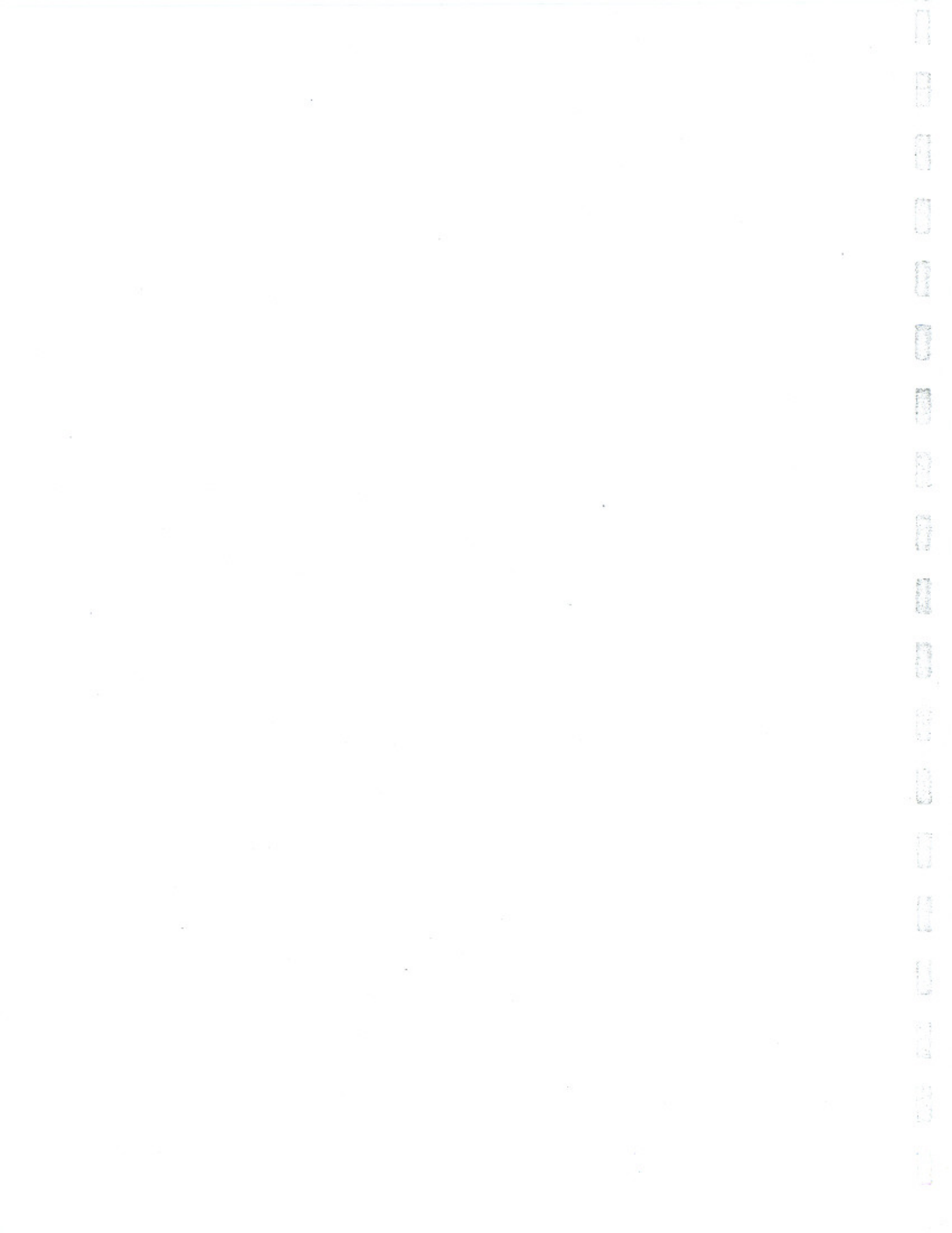

**APPENDIX A**

**UNION CARBIDE CORPORATION  
TECHNICAL INFORMATION**



# TECHNICAL INFORMATION



UNION CARBIDE CORPORATION  
CARBON PRODUCTS DIVISION  
P.O. Box 6116, Cleveland, Ohio 44101

Page 1 of 2

June 15, 1986

UCAR® Graphite Properties  
Grade ATJ (TS-1792)

General: Isostatic Molded Rectangles 16 x 16 x 72"  
Maximum Grain Size: 0.006" (0.15mm)

Property (Room Temperature)	Units English	Typical	Std. Dev.	Units Metric	Typical	Std. Dev.
<u>Full-Piece</u>						
Bulk Density	lbs/ft <sup>3</sup>	108	1.4	Mg/m <sup>3</sup>	1.73	.022
Specific Resistance	10 <sup>-4</sup> ohm-in	4.6	0.4	μΩm	11.8	1.0
<u>Core Piece</u>						
Bulk Density	lbs/ft <sup>3</sup>	109	1	Mg/m <sup>3</sup>	1.74	.018
Specific Resistance	10 <sup>-4</sup> ohm-in			μΩm		
WG		4.0	.033		10.1	.083
AG		4.5	.033		11.3	.083
Young's Modulus	psi x 10 <sup>6</sup>			Gpa		
WG		1.41			9.7	
AG		1.38			9.5	
Modulus of Rupture	psi			Kpa		
WG		3963	307		27311	2112
AG		3522	366		24270	2519
Compressive Strength	psi			Kpa		
WG		8280	914		57052	6300
AG		8155	831		56890	5725
Tensile Strength	psi			Kpa		
WG		3920			27012	
AG		3631			25016	
CTE	10 <sup>-6</sup> /°F			10 <sup>-6</sup> /°C		
WG		1.39	.08		2.50	.14
AG		1.71	.11		3.08	.20



**APPENDIX B**

**GREAT LAKES CARBON  
GRADE H-489**





# Grade H-489

**Application:** Applications for finegrain graphite such as continuous casting, hot pressing, diamond wheel production, glass molds, heating elements and semiconductor jigs and fixtures.

**Size:** Rectangular: 8 x 17" (200 x 430 mm), 9 x 24" (230 x 610 mm),  
 13 x 17" (330 x 430 mm), 13 x 13" (330 x 330 mm),  
 11 x 25" (280 x 635 mm);  
 Round: Up to 20" (508 mm) diameter  
 Lengths: Up to 76" (1900 mm)

## Typical Physical Properties for Grade H-489 Graphite

Property		English Units	Metric Units
Maximum Grain Size		0.003 in.	0.08 mm
Apparent Density		108 lb/ft <sup>3</sup>	1.73 g/cc
Electrical Resistivity	WG	53 x 10 <sup>-5</sup> ohm-in	13 u ohm-m
	AG	63 x 10 <sup>-5</sup> ohm-in	16 u ohm-m
Flexural Strength (four-point loading)	WG	3800 psi	26200 kPa
	AG	3000 psi	20700 kPa
Compressive Strength	WG	7200 psi	49600 kPa
	AG	7200 psi	49600 kPa
Tensile Strength	WG	2700 psi	18600 kPa
	AG	2100 psi	14500 kPa
Modulus of Elasticity	WG	1.2 x 10 <sup>6</sup> psi	8.3 x 10 <sup>6</sup> kPa
	AG	1.0 x 10 <sup>6</sup> psi	6.9 x 10 <sup>6</sup> kPa
Thermal Conductivity	WG	56 BTU/ft-hr-°F	97 W/m-°C
	AG	47 BTU/ft-hr-°F	81 W/m-°C
Coefficient of Thermal Expansion 0°C (32°F) to 50°C (122°F)	WG	13 x 10 <sup>-7</sup> per °F	23 x 10 <sup>-7</sup> per °C
	AG	17 x 10 <sup>-7</sup> per °F	30 x 10 <sup>-7</sup> per °C
Permeability	WG	(No English unit equivalent)	0.011 darcy
	AG		0.009 darcy
Hardness, Rockwell "R" Scleroscope		95	95
		38	38
Available Porosity, 100-0.07 microns		17% of bulk volume	17% of bulk volume
Average Pore Size		0.0001 in.	0.0025 mm
Ash		0.2%	0.2%

Notes: The coefficient of variation may be as high as 10% for the above listed property values.

Properties measured at room temperature unless otherwise noted.

WG - Test specimens cut with the grain.

AG - Test specimens cut against the grain.



**APPENDIX C**

**MISSILE COMMAND SPECIFICATION  
MATERIAL SPECIFICATION  
FOR  
GRAPHITE, ISOSTATICALLY MOLDED  
(MIS-40130)**



## 1. SCOPE

1.1 Scope. This specification covers one type of isostatically molded graphite formed into rectangular blocks from petroleum coke.

## 2. APPLICABLE DOCUMENTS

2.1 Government Documents. The following documents of the issue in effect on date of invitation for bids or request for proposal, form a part of this specification to the extent specified herein.

### STANDARDS

#### Military

MIL-STD-129	Marking for Shipment and Storage
MIL-STD-794	Parts and Equipment, Procedures for Packaging and Packing of

(Copies of specifications, standards, drawings, and publications required by contractors in connection with specific procurement functions should be obtained from the procuring activity or as directed by the contracting officer.)

2.2 Non-government Documents. The following documents form a part of this specification to the extent specified herein. Unless otherwise indicated, the issue in effect on the date of invitation for bids or request for proposal shall apply.

### OTHER PUBLICATIONS

#### American Society for Testing and Materials

ASTM C-559-85	Bulk Density by Physical Measurements of Manufactured Carbon and Graphite Articles
ASTM C-651-70 (1977)	Flexural Strength of Manufactured Carbon Graphite Articles Using Four-Point Loading at Room Temperature
ASTM C 695-81	Compressive (Crushing) Strength of Graphite
ASTM C 611-84	Electrical Resistivity of Manufactured Carbon and Graphite Articles at Room Temperature
ASTM C 561-85	Ash in Graphite
ASTM C 748-83 (1988)	Rockwell Hardness of Fine-Grained Graphite Materials
ASTM C 747-74	Moduli of Elasticity and Fundamental Frequencies of Carbon and Graphite Materials by Sonic Resonance.

### 3. REQUIREMENTS

#### 3.1 General Material Requirements

3.1.1 Character or Quality. The material shall be isostatically molded graphite formed into rectangular blocks in a 16 by 16 by 65 inches configuration by the molding process from petroleum coke having a particle size not greater than 0.006 inches combined with a coal tar pitch and shall conform to the requirements herein. The dimensions of the molded graphite (if other than above) required for delivery shall be as specified in the contract or purchase order (6.2).

3.1.2 Formulation. Not applicable.

3.1.3 Product Characteristics. Not applicable.

3.1.4 Chemical, Electrical, and Mechanical Properties. The chemical, electrical, and mechanical properties shall conform to Table I.

TABLE I. CHEMICAL, ELECTRICAL, AND MECHANICAL PROPERTIES

PROPERTY	VALUES	
	MINIMUM	MAXIMUM
Bulk Density (g/cc)	1.73	1.79
Electrical Resistivity (ohm-cm x 10 <sup>-4</sup> )		
With Grain	-	12.0
Across Grain	-	13.5
Flexural Strength (psi)		
With Grain	3500	-
Across Grain	3500	-
Ash Content (%)	-	0.15
Compressive Strength (psi)		
With Grain	8000	-
Across Grain	8000	-
Rockwell Hardness - L Scale	60	
Elastic Modulus (psi)		
With Grain	1.3 x 10 <sup>6</sup>	-
Across Grain	1.1 x 10 <sup>6</sup>	-

3.1.5 Environmental Conditions. Not applicable.

3.1.6 Stability. Not applicable.

3.1.7 Toxic Products and Safety. Not applicable.

3.1.8 Identification and Marking. Each rectangular block of graphite shall be color-coded red on each end. The with-grain direction shall be marked with an arrow and the letters "WG".

3.1.8.1 Block Serialization. Each block shall be serialized.

3.1.9 Workmanship. The graphite shall be manufactured to assure uniform material free from visual cracks or other defects that would prevent its use for the purpose intended. All graphite shall be certified as being "pip free" (see 6.3).

3.2 Qualification Inspection. The graphite furnished under this specification shall be a product which has been tested and passed the qualification tests specified herein. Any significant changes in methods or process of manufacturing, manufacturing source, or relocation of a manufacturing or process facility of a qualified product shall require qualification as a new product.

#### 4. QUALITY ASSURANCE PROVISIONS

4.1 Responsibility for Inspection. Unless otherwise specified in the contract or purchase order, the supplier is responsible for the performance of all inspection requirements as specified herein. Except as otherwise specified, the supplier may utilize his own facilities or any other inspection facilities and services acceptable to the Government. The Government reserves the right to perform any of the inspections set forth in this specification where such inspections are deemed necessary to assure supplies and services conform to the prescribed requirements.

#### 4.2 Special Tests and Examination

4.2.1 Qualification Provisions. The qualification shall consist of all the quality conformance inspections specified in Table II.

4.3 Quality Conformance Inspection. The inspection and testing of the material shall be classified as quality conformance inspections. The quality conformance inspections shall consist of the examinations and tests specified in Table II.

4.3.1 Sampling. Samples for property measurements identified in Table I shall be taken on each block at three locations (front, middle, and aft) as shown in Figure 1.

4.3.1.1 Test Specimens. From each block, obtain a test slab measuring 2 by 16 by 65 inches. From the test slab, obtain a minimum of three test specimens across the grain and a minimum of three test specimens with the grain from three locations (front, middle, and back) within each block. See Figure 1 for sample orientation. After testing for electrical resistivity, flexural strength, hardness and compression strength, the pieces may be composited and tested for ash content.

TABLE II. QUALITY CONFORMANCE INSPECTIONS

EXAMINATION OR TEST	METHODS PARA	REQUIREMENTS PARA
Character or Quality	4.4.1	3.1.1
Bulk Density	4.4.2	3.1.4
Electrical Resistivity	4.4.3	3.1.4
Flexural Strength	4.4.4	3.1.4
Ash Content	4.4.5	3.1.4
Compressive Strength	4.4.6	3.1.4
Rockwell Hardness	4.4.7	3.1.4
Elastic Modulus	4.4.8	3.1.4
Identification and Marking	4.4.9	3.1.8
Workmanship	4.4.9	3.1.9

#### 4.4 Test Methods

4.4.1 Character or Quality. The supplier shall furnish certification that the graphite block was formed by the isostatic molding process from a petroleum coke having a particle size not greater than 0.006 inch combined with a coal tar pitch.

4.4.2 Bulk Density. Bulk density shall be determined in accordance with ASTM C-559-85. Report the average of the results for each sample location within the block.

4.4.3 Electrical Resistivity. Electrical resistivity shall be determined in accordance with ASTM C 611-84. Report the average of the results for each sample location within the block.

4.4.4 Flexural Strength. Flexural strength shall be determined in accordance with ASTM C 651-70. The sample size shall be 1.0 by 2.0 by 8.0 inches. Report the average of the results for each sample location within the block in the with grain and the across-grain direction.

4.4.5 Ash Content. Ash content shall be determined in accordance with ASTM C-561-85. The following approach is suggested:

- a. Procedure. Weigh a composited sample of approximately 25 grams, to the nearest 0.1 milligram, into a tared 100 cube centimeter platinum or porcelain crucible. Place the weighed sample in the muffle furnace and heat the sample to a temperature of 800 to 900 degrees Celsius (°C) for a

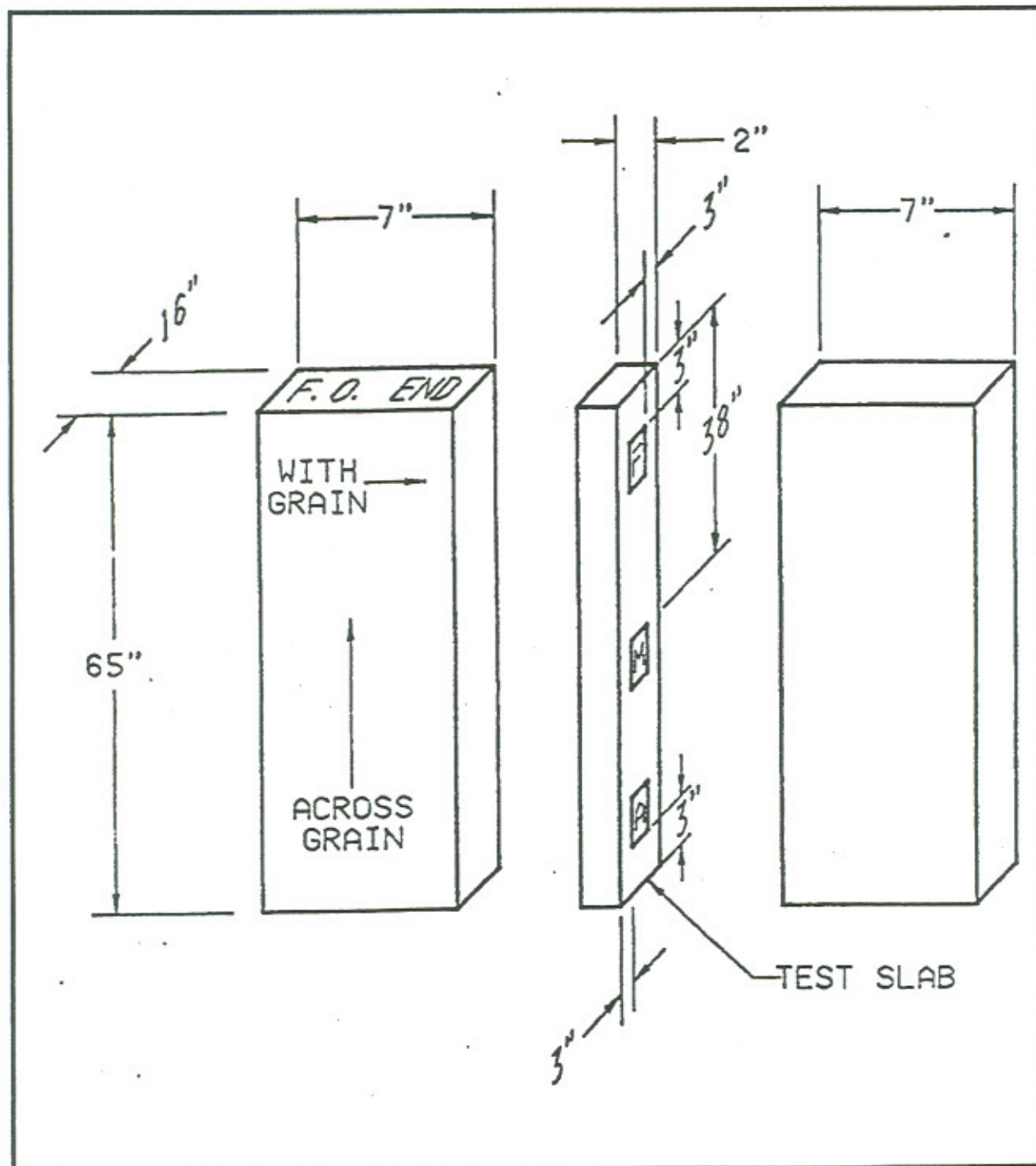

Figure 1. Sampling Plan

Custodian:  
Army - MI

Preparing Activity:  
U.S. Army Missile Command  
Redstone Arsenal, AL 35898  
ERR MI-K4366

minimum of 24 hours. To prevent ash fusion, do not exceed 900 °C. Allow the crucible and sample to cool to room temperature in a desiccator and examine the residue for traces of carbon. If carbon is present, the ignition shall be continued until ashing is complete. Transfer the sample to a desiccator and allow to stand for a minimum of 1 hour before weighing. Then weigh to the nearest 0.1 milligram. Where there is no further visual evidence of carbon, repeat the ignition for 1-hour periods at 800 °C to 900 °C, until a constant weight is obtained.

- b. Calculation. Calculate percent of ash content as follows:

$$\text{Ash Content Percent} = \text{Ash Weight} / \text{Sample Weight} \times 100$$

- c. Report the value for each location.

4.4.6 Compression Strength. Compression strength shall be determined in accordance with ASTM C-695-81 except that the sample size may be a 2.0 inch cube. Report the average of the results for each sample location within the block.

4.4.7 Rockwell Hardness. Hardness shall be determined in accordance with ASTM C-748-83. Report the average results for each sample location within the block.

4.4.8 Elastic Modulus. Elastic modulus shall be determined in accordance with ASTM-C-747. Report the average for each sample location within the block.

4.4.9 Workmanship. The material shall be visually examined for conformance to the workmanship and identification requirements. The material shall be certified as "Pip Free" in conformance with 3.1.9.

4.4.10 Packaging, Packing, and Marking Inspection. Packaging, packing, and marking shall be examined to determine conformance to the requirements of this specification.

## 5. PREPARATION FOR DELIVERY

5.1 Packaging and Packing. Packaging and packing shall be in accordance with level C of MIL-STD-794.

5.2 Marking. Marking shall be in accordance with MIL-STD-129, and shall include but not be limited to, the following:

- a. Title, number, and revision letter of this specification,
- b. Manufacturer's grade designation,
- c. Manufacturer's name,
- d. Lot number,
- e. Contract or purchase order number,
- f. Size of molded graphite item delivered.

## 6. NOTES

6.1 Intended Use. The graphite is intended for use as a solid rocket motor nozzle insert material. Individual billets shall be cut from the block and machined to form nozzle inserts.

6.2 Ordering Data. Procurement documents should specify, but not be limited to, the following:

- a. Title, number, and revision letter of this specification,
- b. Place of delivery,
- c. Dimensions of molded graphite to be delivered (3.1.1.),
- d. Place of inspection,
- e. Request for test results (see Table II).

### 6.3 Definitions

a. Pip free. Pip free means that internal voids or low density regions were not detected using an industry ultrasonic inspection method. A "pip" is an ultrasonic signal that is less than the smallest measurable flaw size, yet still attenuates the signal.

6.4 Suggested Source(s) of Supply. Identification of the suggested source(s) of supply herein is not to be construed as a guarantee of present or continued availability as a source of supply for the item(s). A suggested product conforming to this specification is TS-1792 graphite, manufactured at UCAR Carbon Company, Inc. at Philippi Pike, Anmoore, P.O. Box 2170, Clarksburg, WV 26302.



# 2003 - 2006 Sponsored Acquisition Research Products

## Acquisition Case Series

**NPS-PM-06-044** Lessons Learned from Propulsion System Nozzle Failure on Army TACMS. May 1993.

**NPS-PM-06-041** Boudreau, Michael. Acoustic Rapid COTS Insertion: A Case Study in Spiral Development. October 2006

**NPS-AM-06-008** Apte, Aruna U., and Eugene (Joe) Dutkowski. Total Ownership Cost Reduction Case Study: AEGIS Microwave Power Tubes. May 2006.

**UMD-CM-05-019** Lucyshyn, William, Rene Rendon, and Stephanie Novello. Improving Readiness with a Public-Private Partnership: NAVAIR's Auxiliary Power Unit Total Logistics Support Program. July 2005.

**UMD-CM-05-018** Lucyshyn, William, and Stephanie Novello. The Naval Ordnance Station Louisville: A Case Study of Privatization-in-Place. August 2005.

**NPS-CM-04-008** Lucyshyn, William, Jeffrey Cuskey, and Jonathan Roberts. Privatization of the Naval Air Warfare Center, Aircraft Division, Indianapolis. July 2004.

**NPS-PM-04-010** Lucyshyn, William, Keith F. Snider, and Robert Maly. The Army Seeks a World Class Logistics Modernization Program. June 2004.

**NPS-CM-03-005** Lamm, David V. Contract Closeout (A). September 2003.

## Sponsored Report Series

**UMD-LM-06-040** Gansler, Jacques S., and William Lucyshyn. Evaluation of Performance Based Logistics. August 2006.

**UMD-CM-06-039** Dunn, Richard L.. Contractors Supporting Military Operations. September 2006.

**NPS-FM-06-036** San Miguel, Joseph G. and Donald E. Summers. Public-Private Partnerships for Government Financing, Controlling Risk, and Value for Money: The UK Experience. September 2006.



**NPS-AM-06-035** Naegle, Brad. Developing Software Requirements Supporting Open Architecture Performance Goals in Critical DoD System-of-Systems. September 2006.

**NPS-FM-06-034** San Miguel, Joseph E., and Donald E. Summers. Using Public Private Partnerships and Energy Saving Contracts to Fund DoD Mobile Assets. August 2006.

**NPS-AM-06-032** Apte, Uday, Geraldo Ferrer, Ira Lewis, and Rene Rendon. Managing the Services Supply Chain in the Department of Defense: Opportunities and Challenges. July 2006.

**NPS-AM-06-031** Hudgens, Lt Col Bryan, Capt Carey Petit, Col Rita Jordan, and Lt Col Leon Mable. Development of Measures of Success for Corporate Level Air Force Acquisition Initiatives. July 2006.

**NPS-LM-06-030** Apte, Uday M., Nicholas Dew and Gerald Ferrer. What is the Right RFID for your Service? July 2006.

**NPS-FM-06-029** McCaffery, Jerry, and Larry Jones. Reform of Budgeting for Acquisition: Lessons from Private Sector Capital Budgeting for the Department of Defense. September 2006.

**NPS-LM-06-028** Ferrer, Geraldo, Uday Apte, and Nicholas Dew. What Is the Right RFID for Your Process? July 2006.

**NPS-AM-06-027** Bowman, Dan, Lt Col Timothy S. Reed, Lt Col Bryan J. Hudgens, Maj David Searle. DoD is Not IBM: The Challenges of Implementing Strategic Sourcing in Defense Acquisition. July 2006.

**NPS-PM-06-026** Thomas, Gail Fann, Erik Jansen, and Susan Page Hocesvar. Building Collaborative Capacity in the Interagency Context. July 2006.

**NPS-CM-06-25** Donahue, Capt Kimberly A., Capt Joshua M. Parsons. Government Imposed Constraints and Forecasting Analysis of the M.J. Softe Corporation. December 2004.

**NPS-LM-06-024** Lask, LCDR Gregory R. Advanced SEAL Delivery System: An Analysis of Product Support. July 2006.

**NPS-CM-06-023** Pigeon, SMSgt Nanci R., Lt Col Bryan J. Hudgens, Lt Col Ellen C. England, Lt Col Leon A. Mable, USAF (ret.). The Use of Alternative Dispute Resolution Techniques in United States Air Force Environmental Conflicts. July 2006

**NPS-PM-06-022** Mark Nissen, Mark, Frank Barrett. Changing Major Acquisition Organizations to Adopt the Best Loci of Knowledge, Responsibilities and Decision Rights. July 2006.



**NPS-AM-06-021** Uchtyl, Capt Joseph S. Assessing the Operational Value of Situational Awareness for AEGIS and Ship Self Defense System (SSDS) Platforms through the Application of the Knowledge Value Added (KVA) Methodology. July 2006.

**NPS-AM-06-020** Buchanan, Cap Steven M., Capt Jayson W. Cabell, Capt Daniel C. McCrary. Acquiring Combat Capability through Innovative Uses of Public Private Partnerships. June 2006.

**NPS-FM-06-019** Jankowski, LCDR Patrick, LT Matthew Lehmann, and LT Michael P. McGee. Financing the DOD Acquisition Budget: Innovative Uses of Public-Private Partnerships. June 2006.

**NPS-PM-06-018** Barnum, Usher L., Jr. Business Process Re-Engineering: Application for Littoral Combat Ship Mission Module Acquisition. June 2006.

**NPS-AM-06-017** Mun, Johnathan, and Thomas Housel. A Primer on Return On Investment and Real Options Analysis for Portfolio Optimization. July 2006.

**NPS-AM-06-014** Hatch II, William D. CDR, USN, Charles Gowen, AmerInd/FC Business Systems, and James Loadwick, AmerInd/FC Business Systems. Littoral Combat Ship (LCS) Civilian Aviation Alternative Support Study: Report of Findings and Recommendation. July 2006.

**NPS-AM-06-012** Meyer, Jacqueline M. and Sefa Demirel. A Comparative Analysis of the Department of Defense (DoD) Passive Radio Frequency Identification (RFID) Policy and Perspective in Terms of Site Implementations. June 2006

**NPS-AM-06-010** Rendon, Rene G. Using a Modular Open Systems Approach in Defense Acquisitions: Implications for the Contracting Process. January 2006.

**NPS-LM-06-009** Apte, Uday M., Nicholas Dew and Gerald Ferrer. What is the Right RFID for your Process? January 2006.

**NPS-LM-06-007** Mullins, Captain Michael, US Marine Corps, Captain Troy Adams, US Marine Corps and Lieutenant Robert Simms, US Navy. Analysis of Light Armored Vehicle Depot Level Maintenance. December 2005.

**NPS-CM-06-006** Cortese, Captain Casey A., US Air Force, First Lieutenant Heather Shelby, US Air Force and Captain Timothy J. Strobel, US Air Force. Defining Success: The Air Force Information Technology Commodity Council. December 2005.

**NPS-LM-06-005** Hernandez, Captain Emeterio V., US Air Force and Lieutenant Christopher A. Thomas, US Navy. Investigating the Department of Defense's Implementation of Passive Radio Frequency Identification (RFID). December 2005.



**NPS-FM-06-004** Rios, Jr., LCDR Cesar G., US Navy. Return on Investment Analysis of Information Warfare Systems. September 2005.

**NPS-AM-06-003** Komoroski, Christine L. Reducing Cycle Time and Increasing Value through the Application of Knowledge Value Added Methodology to the U.S. Navy Shipyard Planning Process. December 2005.

**UMD-AM-05-021** Gansler, Jacques S., and William Lucyshyn. A Strategy for Defense Acquisition Research. August 2005.

**UMD-CM-05-020** Dunn, Richard. Contractors in the 21st Century "Combat Zone." April 2005.

**NPS-PM-05-017** Brianas, Christopher G. Department of the Navy Procurement Metrics Evaluation. June 2005.

**NPS-LM-05-016** Doerr, Kenneth H., RADM Donald R. Eaton and Ira A. Lewis. Impact of Diffusion and Variability on Vendor Performance Evaluation. October 2005.

**NPS-CM-05-015** Johnson, Ellsworth K. III, Bryan H. Paton, Edward W. Threat, and Lisa A. Haptonstall. Joint Contingency Contracting. June 2005.

**NPS-CM-05-013** Schwartz, Brett M., Jadon Lincoln, Jose L. Sanchez, and Leslie S. Beltz. Update of the Navy Contract Writing Guide Phase III. June 2005.

**NPS-PM-05-012** Jenkins, Glenn E., and William J. Snodgrass, Jr. The Raven Small Unmanned Aerial Vehicle (SUAV): Investigating Potential Dichotomies between Doctrine and Practice. June 2005.

**NPS-AM-05-011** Apte, Aruna U. Spiral Development: A Perspective. June 2005.

**NPS-FM-05-009** Jones, Lawrence R., Jerry McCaffery and Kory L. Fierstine. Budgeting for National Defense Acquisition: Assessing System Linkage and the Impact of Transformation. June 2005.

**NPS-LM-05-008** Kang, Keebom, Kenneth Doerr, Michael Boudreau, and Uday Apte. A Decision Support Model for Valuing Proposed Improvements in Component Reliability. June 2005.



**NPS-PM-05-007** Dillard, John T., and Mark E. Nissen. Determining the Best Loci of Knowledge, Responsibilities and Decision Rights in Major Acquisition Organizations. June 2005.

**NPS-AM-05-006** San Miguel, Joseph G., John K. Shank, and Donald E. Summers. Navy Acquisition via Leasing: Policy, Politics, and Polemics with the Maritime Prepositioned Ships. April 2005.

**NPS-CM-05-003** Rendon, Rene G. Commodity Sourcing Strategies: Supply Management in Action. January 2005.

**NPS-CM-04-019** Lord, Roger. Contractor Past Performance Information (PPI) In Source Selection: A comparison Study of Public and Private Sector. December 2004.

**NPS-PM-04-017** Matthews, David. The New Joint Capabilities Integration Development System (JCIDS) and Its Potential Impacts upon Defense Program Managers. December 2004.

**NPS-LM-04-014** Apte, Aruna. Optimizing Phalanx Weapon System Lifecycle Support. October 2004.

**NPS-AM-04-013** Frank, Raymond (Chip). Business Case Analysis and Contractor vs. Organic Support: A First-Principles View. September 2004.

**NPS-LM-04-006** Doerr, Ken, Donald R. Eaton, and Ira Lewis. Measurement Issues in Performance Based Logistics. June 2004.

**NPS-CM-04-004** Espine, Lieutenant Commander Joseph C., and Lieutenant Commander Chong Hunter. Update of the Navy Contract Writing, Phase II. June 2004.

**NPS-CM-04-002** Burger, Major Kenneth A., Captain Brian . Marine Corps Contingency Contracting MCI. Revised Manual. December 2003.

**NPS-CM-04-001** Dean, Captain Chad E., and Second Lieutenant Nathan P. Vosters. Update of the Navy Contract Writing, Phase I. December 2003.

**NPS-CM-03-006** Tudor, Ron B. Auto-Redact Toolset for Department of Defense Contracts. September 2003.



**NPS-AM-03-004** Boudreau, Michael W., and Brad R. Naegle. Reduction of Total Ownership Cost. September 2003.

**NPS-AM-03-003** Dillard, John T. Centralized Control of Defense Acquisition Programs: A Comparative Review of the Framework from 1987-2003. September 2003.

**NPS-CM-03-001** MBA Team. Transformation in DoD Contract Closeout. June 2003.

## **Working Paper Series**

**NPS-LM-06-013** Dew, Nicholas. Cookies for the Real World: Assessing the Potential of RFID for Contractor Monitoring. May 2006.

**NPS-PM-06-002** Dillard, John T. When Should You Terminate Your Own Program? November 2005.

**NPS-AM-06-001** Naegle, Brad. Developing Software Requirements Supporting Open Architecture Performance Goals in Critical DoD System-of-Systems. November 2005.

**NPS-AM-05-010** Zolin, Roxanne V., and John T. Dillard. From Market to Clan: How Organizational Control Affects Trust in Defense Acquisition. June 2005.

**NPS-AM-05-005** Boudreau, Michael. Cost as an Independent Variable (CAIV): Front-End Approaches to Achieve Reduction in Total Ownership Cost. June 2005.

**NPS-AM-05-002** Yoder, Elliott Cory. The Yoder Three-Tier Model for Optimizing Contingency Contracting Planning and Execution. December 2004.

**NPS-AM-05-001** Yoder, Elliott Cory. Engagement versus Disengagement: How Structural & Commercially-Based Regulatory Changes have Increased Government Risks in Federal Acquisitions. November 2004.

**NPS-CM-04-016** Stevens, Brett. An Analysis of Industry's Perspective on the Recent Changes to Circular A-76. October 2004.

**NPS-CM-04-012** Rairigh, Beth. Air Force Commodity Councils: Leveraging the Power of Procurement. September 2004.

**NPS-CM-04-011** Engelbeck, R. Marshall. Using Metrics to Manage Contractor Performance. September 2004.



**NPS-LM-04-009** Eaton, Donald R. Improving the Management of Reliability. August 2004.

**NPS-AM-04-007** Naegle, Brad R. The Impact of Software Support on System Total Ownership Cost. July 2004.

**NPS-LM-04-003** Eaton, Donald R. Enablers to Ensure a Successful Force Centric Logistics Enterprise. April 2004.

**NPS-CM-03-002** Parker, Christopher and Michael Busansky. Transformation in DoD Contract Closeout. June 2003.

## **Acquisition Symposium Proceedings**

**NPS-AM-06-011** Acquisition Research: Creating Synergy for Informed Change. April 2006.

**NPS-AM-05-004** Acquisition Research: The Foundation for Innovation. May 2005.

**NPS-AM-04-005** Charting a Course for Change: Acquisition Theory and Practice for a Transforming Defense. May 2004.

## **Technical Reports**

**NPS-GSBPP-03-003** Dillard, John T. Centralized Control of Defense Acquisition Programs: A Comparative Review of the Framework from 1987-2003. September 2003.

**NPS-GSBPP-03-004** Boudreau, Michael W., and Brad R. Naegle. Reduction of Total Ownership Cost. September 2003.

## **Presentations, Publications and External Forums**

Rendon, Rene. "Commodity Sourcing Strategies: Supply Management in Action." Published as "Commodity Sourcing Strategies: Processes, Best Practices, and Defense Initiatives." *Journal of Contract Management* 3, no.1 (2005): 7-21.

Doerr, Ken, Ira Lewis, and Donald Eaton. "Measurement issues in Performance Based Logistics." *Journal of Public Procurement* 5, no. 2 (2005): 164-186.

Eaton, Donald, Ken Doerr, and Ira Lewis. "Performance Based Logistics: A Warfighting Focus." *US Naval Institute Proceedings*. (In Press).



Doerr, Ken, Donal Eaton, and Ira Lewis. "Performance Based Logistics." Presented to the International Defense Acquisition Resource Management Conference. Capellen, Luxembourg, 2004.

Kang, Keebom, and Ken Doerr. Workshop: Metrics and Performance Evaluation in Performance Based Logistics. Presented at Future Naval Plans & Requirements Conference. San Diego, CA. October 2005.

Boudreau, Michael, and Brad Naegle. "Total Ownership Cost Considerations in Key Performance Parameters and Beyond." *Defense Acquisition Research Journal* 38, no.2 (2005): 108-121.

Boudreau, Michael, and Brad Naegle. Workshop: Setting up Acquisition for Total Lifecycle Supportability Performance. Presented at the Institute for Defense and Government Advancement Conference: Total Lifecycle Systems Management. Arlington, VA. 2005.

Kang, Keebom, Ken Doerr, Uday Apte, and Michael Boudreau. "Decision Support Models for Valuing Improvements in Component Reliability and Maintenance." Submitted to the Journal of Defense Modeling and Simulation in July 2005 for possible publication. Currently the article is being reviewed by referees.

Franck, Raymond (Chip). "Business Case Analysis and Contractor vs. Organic Support: A First-Principles View." Presented at the Western Economic Association International Annual Conference. San Francisco, CA. 5 July 2005.

Dillard, John, and Mark Nissen. "Computational Modeling of Project Organizations under Stress." In review.

Dillard, John. "Centralization of Defense Acquisition Programs." Accepted for publication in the *Defense Acquisition Research Journal* (2005).

Nissen, Mark E., and John Dillard. "Computational Design of Public Organizations." In review.

IS4710 - Qualitative Methods. This research-seminar course has integrated the results of the FY05 Dillard-Nissen research into the students' course project.

Dillard, John T. "Centralized Control of Defense Acquisition Programs." IAMOT 2004 - New Directions in Technology Management: Changing Collaboration between Government, Industry and University. 3 -7 April 2004.



Dillard, John T. "Centralized Control of Defense Acquisition Programs: A Comparative Review of the Framework from 1987-2003." BPP Research Colloquium. 25 November 2003.

Copies of the Acquisition Sponsored Research Reports may be printed from our website [www.acquisitionresearch.org](http://www.acquisitionresearch.org)



ACQUISITION RESEARCH PROGRAM  
GRADUATE SCHOOL OF BUSINESS & PUBLIC POLICY  
NAVAL POSTGRADUATE SCHOOL

THIS PAGE INTENTIONALLY LEFT BLANK



ACQUISITION RESEARCH PROGRAM  
GRADUATE SCHOOL OF BUSINESS & PUBLIC POLICY  
NAVAL POSTGRADUATE SCHOOL



ACQUISITION RESEARCH PROGRAM  
GRADUATE SCHOOL OF BUSINESS & PUBLIC POLICY  
NAVAL POSTGRADUATE SCHOOL  
555 DYER ROAD, INGERSOLL HALL  
MONTEREY, CALIFORNIA 93943

[www.acquisitionresearch.org](http://www.acquisitionresearch.org)