

## A PHASE COMPARISON METHOD SUITABLE TO MEASURE H-MASER PERFORMANCE

R. Ambrosini  
Istituto di Radioastronomia CNR,  
v. Irnerio 46, 40126  
Bologna, Italy

### INTRODUCTION

Very Long Baseline Interferometry is one of the modern specialized applications where phase noise instability has to be characterized not only for short term, but also over very long periods of time. This technique is utilized by radioastronomers to draw sky maps with angular resolutions of a few milliarcseconds and by geophysicists to measure continental plate motions, with precisions of a few centimeters across earth diameter distances. These types of observations are performed by networks of radiotelescope antennas, each of which needs a H-Maser frequency standard to preserve, in the receiving down conversion mixing process, the phase of the signal coming from sky radio sources.

The present work was started to develop some simple instrumentation capable of characterizing the residual phase noise instability of the different local oscillator chains of the VLBI receivers over integration times up to 10,000 s, at their output frequencies ranging from 500 MHz up to 24 GHz. Then, realizing the importance of evaluating the absolute noise originating from the primary references, we have investigated the possibility of performing the phase comparison of our H-Maser frequency standards. While, in both cases, the short term part of the noise spectrum can be measured in a standard way, in the frequency domain, by an FFT analyzer and a phase detector, the long term part of the spectrum is generally measured with a digital read by a computer while the two devices under test are artificially offset in frequency by a suitable amount.

This paper suggests how to simplify and to extend the usefulness of the hardware utilized in the measurement of short term phase noise to characterize the long term part of the spectrum also, for virtually infinite integration times. The required additional hardware is a general purpose interface for a personal computer and some minor components. In particular, a simple discrete phase rotator has been implemented, so it becomes easy to handle different comparison frequencies.

### THE EXPERIMENTAL SET-UP

A block diagram of the measurement set-up is shown in Fig.1. In the case of absolute noise measurement, a small variable frequency offset will always exist between the two sources under test, so the phase comparator has to reconstruct unambiguously and accurately the input phase over the full round angle and beyond that up to infinity.

In the proposed set-up a double balanced mixer acts as a real time phase detector. Its ideal output transfer characteristic is, of course, a pure sinusoidal function of the input phase. This dependence can be easily inverted by the computer that acquires the data. In this way, the input phase can be

# Report Documentation Page

*Form Approved  
OMB No. 0704-0188*

Public reporting burden for the collection of information is estimated to average 1 hour per response, including the time for reviewing instructions, searching existing data sources, gathering and maintaining the data needed, and completing and reviewing the collection of information. Send comments regarding this burden estimate or any other aspect of this collection of information, including suggestions for reducing this burden, to Washington Headquarters Services, Directorate for Information Operations and Reports, 1215 Jefferson Davis Highway, Suite 1204, Arlington VA 22202-4302. Respondents should be aware that notwithstanding any other provision of law, no person shall be subject to a penalty for failing to comply with a collection of information if it does not display a currently valid OMB control number.

1. REPORT DATE <b>DEC 1986</b>	2. REPORT TYPE	3. DATES COVERED <b>00-00-1986 to 00-00-1986</b>			
4. TITLE AND SUBTITLE <b>A Phase Comparison Method Suitable to Measure H-Maser Performance</b>		5a. CONTRACT NUMBER			
		5b. GRANT NUMBER			
		5c. PROGRAM ELEMENT NUMBER			
6. AUTHOR(S)		5d. PROJECT NUMBER			
		5e. TASK NUMBER			
		5f. WORK UNIT NUMBER			
7. PERFORMING ORGANIZATION NAME(S) AND ADDRESS(ES) <b>Instituto di Radioastronomia CNR,v. Irnerio 46, 40126,Bologna, Italy,</b>		8. PERFORMING ORGANIZATION REPORT NUMBER			
9. SPONSORING/MONITORING AGENCY NAME(S) AND ADDRESS(ES)		10. SPONSOR/MONITOR'S ACRONYM(S)			
		11. SPONSOR/MONITOR'S REPORT NUMBER(S)			
12. DISTRIBUTION/AVAILABILITY STATEMENT <b>Approved for public release; distribution unlimited</b>					
13. SUPPLEMENTARY NOTES <b>Proceedings of the Eighteenth Annual Precise Time and Time Interval (PTTI) Applications and Planning Meeting, Washington, DC, 2-4 Dec 1986</b>					
14. ABSTRACT					
15. SUBJECT TERMS					
16. SECURITY CLASSIFICATION OF:			17. LIMITATION OF ABSTRACT <b>Same as Report (SAR)</b>	18. NUMBER OF PAGES <b>7</b>	19a. NAME OF RESPONSIBLE PERSON
a. REPORT <b>unclassified</b>	b. ABSTRACT <b>unclassified</b>	c. THIS PAGE <b>unclassified</b>			

correctly read over the  $\pm 60$  degree range. To cover the full round angle phase input range, a simple discrete phase rotator has been implemented. Under computer control, three coaxial cables of different electrical lengths, in almost 120 degree step progression, can be switched sequentially to bring back the input phase, whenever needed, within the range of the mixer. In this manner, the phase difference between the two sources can be tracked continuously for a virtually infinite time. To preserve mixer linearity, its output port is properly terminated into a broadband high frequency matched load. This is followed by a low-pass filter and a low-noise amplifier, before applying the signal to an analog to digital converter, which is read by a personal computer finally controlled by a software program very similar to the one proposed by S. Weinreb[1]. The same signal can also be analyzed by an FFT analyzer to measure the short term phase noise. To emulate the required noise bandwidth of 1 Hz, the actual A/D device is a voltage to frequency converter which integrates the input signal for 160 ms. To have one measurement per second, the computer waits for the remaining 840 ms between the consecutive measurements, while making the necessary calculations in real time.

The software displays on the monitor the instantaneous input phase in picoseconds then, periodically plots the averaged Allan Variance at 1 s, the frequency difference between the two sources and the ambient temperature. After having acquired a selectable amount of data, a hard copy of the last batch is produced, together with the cumulative statistics from the beginning of the measurement. Allan variances over the integration times from 1 s to 100,000 s are computed 1 a 1,2,5 progression for every decade.

#### SYSTEM CALIBRATION

Before starting a measurement session at some new mixing frequency, a CALIBration program is run to measure the system parameters. When a low frequency beat signal is applied between the two sources under test, it is possible to choose the appropriate gain for the preamplifier to achieve the required sensitivity within the optimum resolution range of the A/D converter (+10/-8 volts). In this way the peak amplitude of the beat tone is measured together with its DC offset with respect to ground, so this last quantity need not be compensated by hardware trimming. This is a very convenient feature because the actual offset depends on the particular operating parameters of the mixer, which have to be optimized. The previous two quantities and the input mixing frequency are needed by the main program FSAUTO to retrieve correctly the input phase.

Before every measurement session, the cables are automatically switched in sequence to resolve the  $\pm 180$  degree ambiguity intrinsic in the sine function, or, in other words, just to know the correct cable switching sequence (CW or CCW) to correct the phase drift. During the program run, if the input phase drifts over  $\pm 1.2$  radians, the computer automatically selects the successive cable to keep the input phase within the working range of the mixer.

The electrical length of each cable is measured in real time as the difference of phase between the last measure before the cable switch and the first one with the new cable, executed one second later. The result result is also corrected for the average frequency offset between the two sources, as measured just before the switching action.

## ACCURACY VERIFICATION

In a conventional system noise floor measurement, when a single source feeds both mixer inputs, it is possible to verify the the level of phase instability introduced by the A/D converter, the amplifier and the mixer, this 1st assumed to have a pure sinusoidal transfer function. Fig.2 shows the results obtained after a measurement period of 150,000 s and relative to the experimental set-up designed to compare two H-Masers at 180 MHz. During that test, the three cables were artificially scanned sequentially every 1000 s, to check also the amount of noise introduced by the switching action. On the other hand, by this simple test it is not possible to evaluate the noise contribution due to the non-ideal transfer function of the mixer. The higher harmonics, shown by an FFT spectrum analysis of the beat tone applied between the two sources, can be interpreted as the impure sinusoidal response of the mixer; in fact they are the higher order terms of the Fourier series expansion of its output signal. This technique allows the optimization, almost in real time of the mixer performance, for example the drive levels, to achieve the the highest fundamental to harmonics ratio.

These harmonics, during the actual measurement when the beat tone is removed, will generate a periodic "ripple" over the ideal sine response of the mixer, or an error on the retrieved phase. Because this effect is generally relevant only in absolute noise measurements, it has been analyzed, in our case. only for the experimental set-up dedicated to the evaluation of the two H-Masers. Because the ripple noise is uncorrelated with the phase instability to be measured, it is expected that the combined variance should be equal to the sum of the two respective components. It can be immediately realized that this effect should be negligible both for short and for long integration times because the mixer sinusoidal slope is scanned at the reasonably low "speed" due to the residual frequency offset between the two H-Masers.

As a first approximation it has been considered that three times the square root of the Allan variance measured in 1 second, 1 ps in our case, should also be the maximum allowed mixer non-linearity, leaving for a later computer simulation the full analysis of the problem[2]. When almost no beat frequency is present, the phase accuracy retrieval at the  $\pm 1.12$  radians points of the fundamental mixer response can be quickly checked by comparing with the full round angle the sum of the electrical lengths of the three delay cables, as measured by the system itself. Then, to verify that the same accuracy is available across the whole working range of the phase comparator, it was verified that the retrieval step of phase, obtained by switching between two cable almost equal in length, was every time the same independent of the particular point of the fundamental mixer response chosen to start the measurement. This constancy has been verified to be within the limit described before.

## MEASUREMENTS ON H-MASER FREQUENCY STANDARDS

Figure 3 is a photograph of the thermostatically controlled H-Maser room at the Italian VLBI station at Medicina, with the programmable phase comparator described in the text just on top of the two frequency standards. In Figure 4, only the final cumulative plot of the Allan variance for TAUs from 1 s up to 100,000 s is shown. This plot is relative to a measurement period of 576,356 s (almost seven days). Due to obvious space limitations, the twelve hard copies

of the intermediate results, obtained over single batches of 50010 s are not shown.

Finally, these results have also been found fully consistent with those obtained by the more conventional technique of measuring the frequency instabilities of a 0.5 Hz beat period available at 180 MHz when one H-Maser is fully offset with respect to the other.

#### CONCLUSIONS

The proposed measurement set-up seems to be attractive for its simplicity and low cost, particularly when no frequency offset is allowed between the two sources to be compared and when it is required to measure long term phase instabilities at many different comparison frequencies. In fact, the software accepts the mixing frequency as an input parameter, while the hardware generally needs only minor modifications. When performing residual phase noise measurements, no particular problems generally arise. The phase quadrature requirement can be relaxed because the linear response of the mixer has been extended by anti-transforming its sinusoidal transfer function. By this technique, frequency synthesizers and multipliers have been characterized for integration times up to 100,000 s.

If, on the other hand, absolute phase noise of very high stability sources is to be checked, before performing actual measurements it is necessary to verify not only the system noise floor, but also the real mixer linear response, as a phase detector. Its behavior can be optimized in real time by standard techniques and its contribution to the final result can be evaluated either by hardware methods for every particular experimental set up, or by a computer simulation[2].

Actual measurements of H-Maser phase instabilities over significant periods of time are reported showing the usefulness of this technique. Because the actual parameter measured by the system is the value of the input phase, it is possible to record it directly on a chart recorder, obtaining a very useful and sensitive technique to point out spikes or jumps and to find if they are related to some external interference. For the same reason, the last but not least capability of the proposed measuring is to be intrinsically able to compute directly the power spectral density of the input phase.

## ACKNOWLEDGEMENT

I would like to heartily thank Dr. Sander Weinreb of the NRAO, Charlottesville, VA, for his very helpful comments. I am also grateful to Mauro Roma for his active technical assistance.

## REFERENCES

- [1] S. Weinreb, "Frequency Standard Test Program", NRAO Electronics Division Internal Report No.232, March 1983
- [2] R. Ambrosini, M. Caporali, "A simple and versatile phase comparison method can accurately measure long term instability", sent to the IEEE to be eventually published in the Transactions on Instrumentation and Measurements.

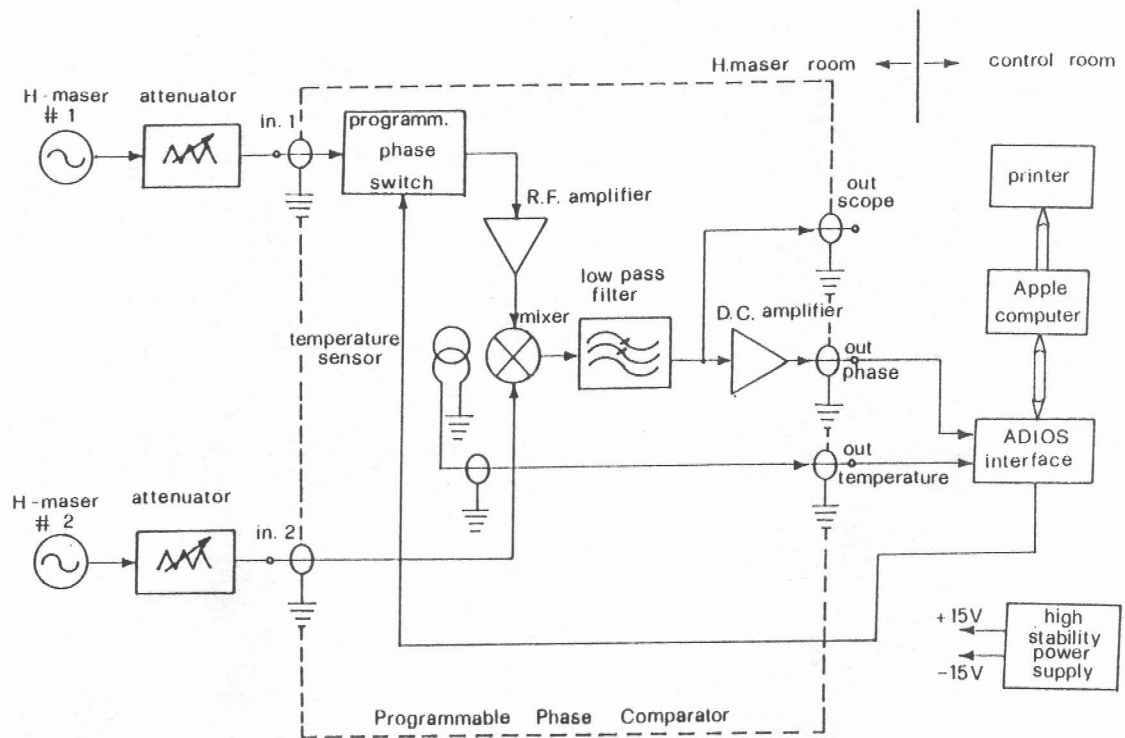

1 - The hardware configuration of the proposed set-up. The dashed line around the PPC identifies the passive thermal insulation from ambient.

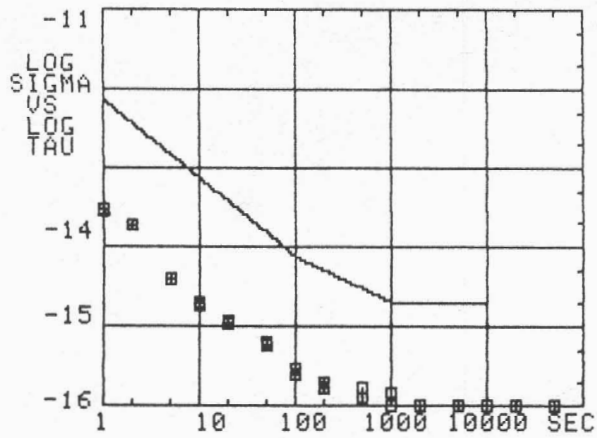

2 - Noise floor measured at 180 MHz for a period of time of 150,000 s.

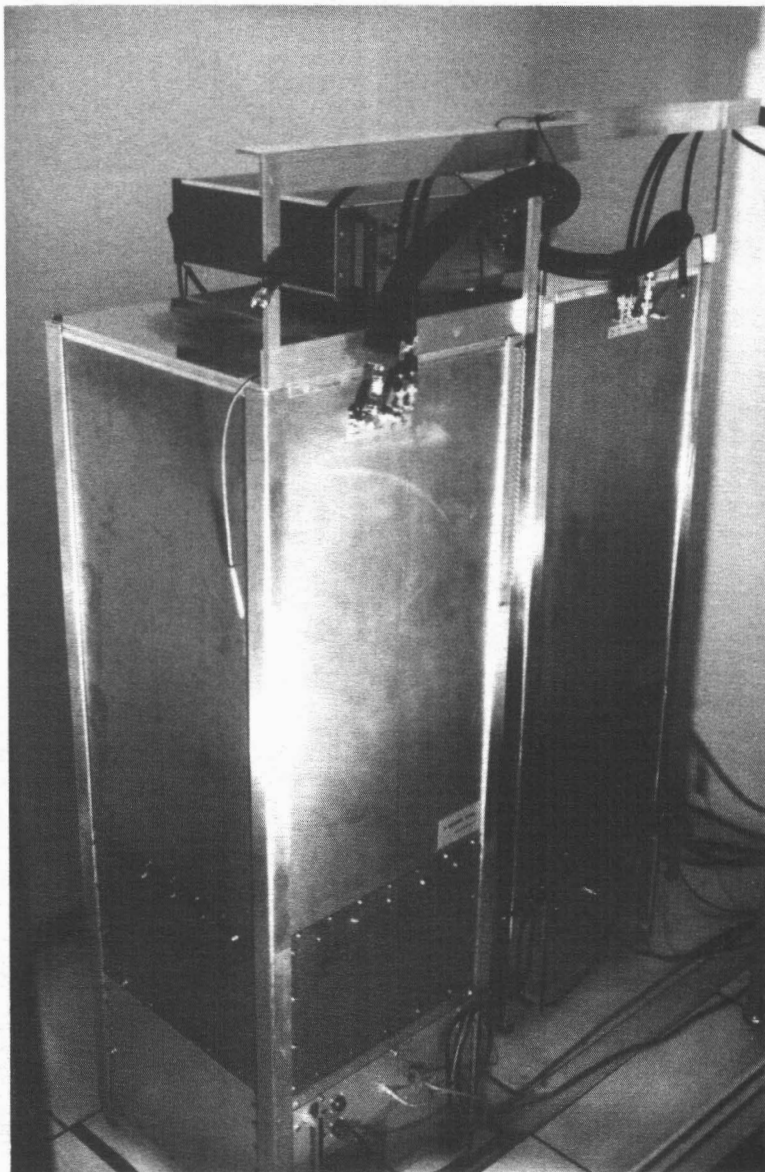

3 - The H-Maser thermostatically controlled room. The PPC is the box just on top of the atomic standards.

E4(f.103) vs E5(f.115) after sp/exc

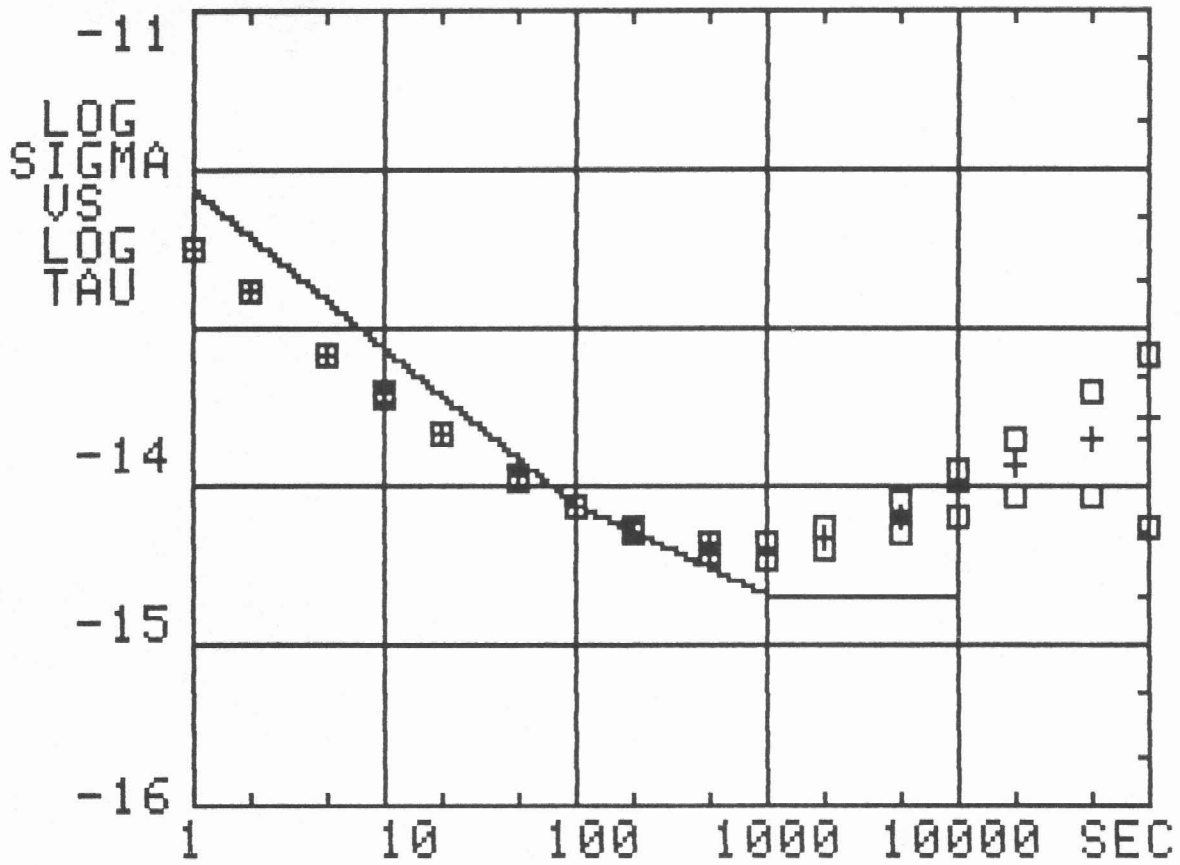

4 - The final plot of the Allan Variance measured comparing EFOS4 vs EFOS5 for a continuous period of 576,356 s, almost seven days.