

REMOTE FIELD EDDY CURRENT MILITARY AND COMMERCIAL PLATFORM APPLICATIONS

Yushi Sun, Innovative Materials Testing Technologies, Inc.
John C. Brausch, Kenneth J. LaCivita, Lt William Sanders, Air Force Research Laboratory

Introduction

A new development in NDI (nondestructive inspection) electromagnetic, eddy current technology enables users to inspect conductive materials under thick layers of composite and find subsurface flaws in thick aluminum, titanium and steel structure. The method is called Remote Field Eddy Current (RFEC). A group of Scientists refined this technology after years of working with Flat Geometry Remote Field Eddy Current (FG_RFEC) technique, as well as in finite element modeling of electromagnetic NDI phenomena [1- 4]. A new eddy current instrument, Super-Sensitive-Eddy-Current (SSEC) system with extremely high gain, 100 dB – 140 dB, has also been developed to deal with the low level signals obtained from the FG_RFEC technique after deep penetration.

Conventional eddy current techniques, ECT, are capable of detecting only surface and subsurface flaws due to restriction of the skin-depth equation. FG_RFEC technique with the SSEC system allows measurement of signals that have penetrated through the whole wall thickness. Skin-depth is no longer the limit in flaw detection. Meantime, the technique also has high sensitivity to surface and subsurface flaws due to the high gain of the SSEC system.

In recent years, a number of possible applications of the FG_RFEC technique have been found in aircraft and aerospace industries [5-13].

As the aircraft industry is driven to reduce structural weight, increase corrosion resistance, and cost savings, more aircraft designs are utilizing composite materials attached to a metallic substrate of aluminum and titanium. This design retains the strength and durability characteristics of traditional metals, while reducing weight and increasing corrosion resistance. As these new materials are developed for use on new aircraft platforms, so must the NDI technology be developed to inspect them. NDI is necessary in the development, article testing and the operational phases of the aircraft structure. New commercial aircraft platforms such as the Airbus A380, Boeing 787, are incorporating similar structure in their designs. Existing military platforms also incorporate the composite/metallic structure and future platforms will most likely use this type of structure. In some cases older commercial designs incorporated nonmetallic barriers in fuel cells and other wet areas of the aircraft, to reduce corrosion and seal fuel cells. Some of these areas may now, for the first time, be assessed during operational phases utilizing the RFEC technology.

The paper presents some examples of remote field eddy current capabilities covering six new aircraft applications: 1) Detection of aluminum layer cracks through one and half inch of polycarbonate; 2) Detection of aluminum layer cracks through thick graphite epoxy composite; 3) Detection of titanium layer cracks through thick graphite epoxy composite; 4) Detection of cracks in a titanium layer through a thick graphite epoxy composite and suppression of sealant groove signals; 5) Detection of cracks 0.50” below a aluminum top layer structure surface; 6) Detection of fine surface and subsurface cracking on curved steel surface in a Airbus A-320 landing gear structure.

The next step is to assess existing or new inspections to find the right fit and application of this advanced technology that is now available to our industry.

Report Documentation Page

*Form Approved
OMB No. 0704-0188*

Public reporting burden for the collection of information is estimated to average 1 hour per response, including the time for reviewing instructions, searching existing data sources, gathering and maintaining the data needed, and completing and reviewing the collection of information. Send comments regarding this burden estimate or any other aspect of this collection of information, including suggestions for reducing this burden, to Washington Headquarters Services, Directorate for Information Operations and Reports, 1215 Jefferson Davis Highway, Suite 1204, Arlington VA 22202-4302. Respondents should be aware that notwithstanding any other provision of law, no person shall be subject to a penalty for failing to comply with a collection of information if it does not display a currently valid OMB control number.

1. REPORT DATE 01 APR 2006	2. REPORT TYPE N/A	3. DATES COVERED -			
4. TITLE AND SUBTITLE Remote Field Eddy Current Military And Commercial Platform Applications		5a. CONTRACT NUMBER			
		5b. GRANT NUMBER			
		5c. PROGRAM ELEMENT NUMBER			
6. AUTHOR(S)		5d. PROJECT NUMBER			
		5e. TASK NUMBER			
		5f. WORK UNIT NUMBER			
7. PERFORMING ORGANIZATION NAME(S) AND ADDRESS(ES) Innovative Materials Testing Technologies, Inc.		8. PERFORMING ORGANIZATION REPORT NUMBER			
9. SPONSORING/MONITORING AGENCY NAME(S) AND ADDRESS(ES)		10. SPONSOR/MONITOR'S ACRONYM(S)			
		11. SPONSOR/MONITOR'S REPORT NUMBER(S)			
12. DISTRIBUTION/AVAILABILITY STATEMENT Approved for public release, distribution unlimited					
13. SUPPLEMENTARY NOTES 2006 JCAA Presentation, The original document contains color images.					
14. ABSTRACT					
15. SUBJECT TERMS					
16. SECURITY CLASSIFICATION OF:			17. LIMITATION OF ABSTRACT UU	18. NUMBER OF PAGES 16	19a. NAME OF RESPONSIBLE PERSON
a. REPORT unclassified	b. ABSTRACT unclassified	c. THIS PAGE unclassified			

FG_RFEC probes & SSEC system

There are two kinds of FG_RFEC probes often used for crack and corrosion detection: sliding probes and rotational probes. Sliding probes are simple and easy in use, while a rotational probe, which is rotating around a fastener, provides higher sensitivity to cracks under fasteners, because minimum signal from the fastener appears in detected crack signals. Figure 1 shows typical FG_RFEC probes to be used in this paper.

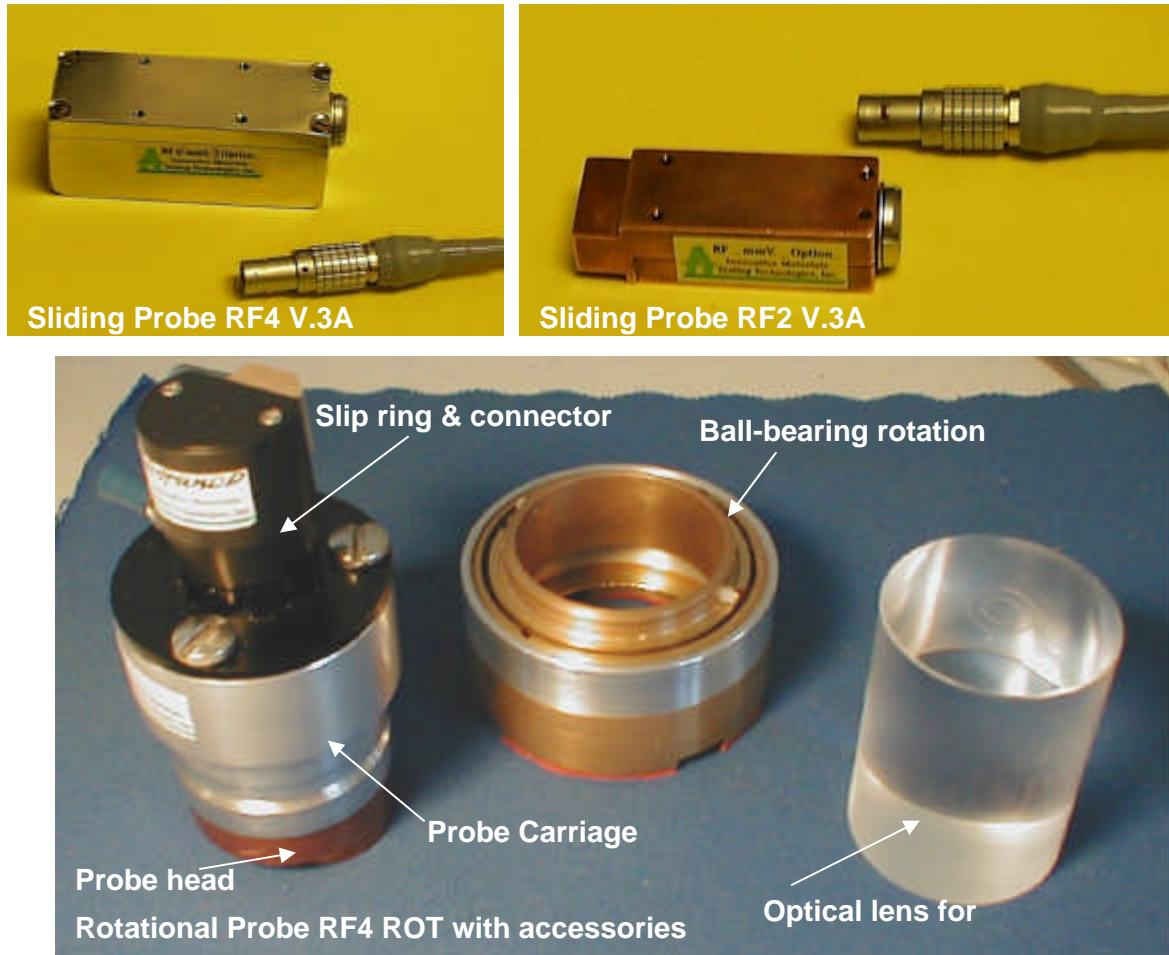

Figure 1: Typical FG_RFEC probes to be used in this paper

SSEC system is a modified version of a conventional eddy current (EC) instrument. It is characterized by the features below:

1. High gain: up to 100 – 140 dB, and low S/N (signal to noise) ratio;
2. Computerization: it utilizes a PC as its base;
3. Compatibility with conventional EC probes. In other words, it works with any conventional EC probe. Conversion to conventional probe operation is achieved by changing the probe connector.

A photo of such a system working with a laptop PC is shown in Figure 2. The system consists of a 12"×8.75"×1.75" hardware box and installed software. The PC can be of customer selection: a desk-top or a lap-top.

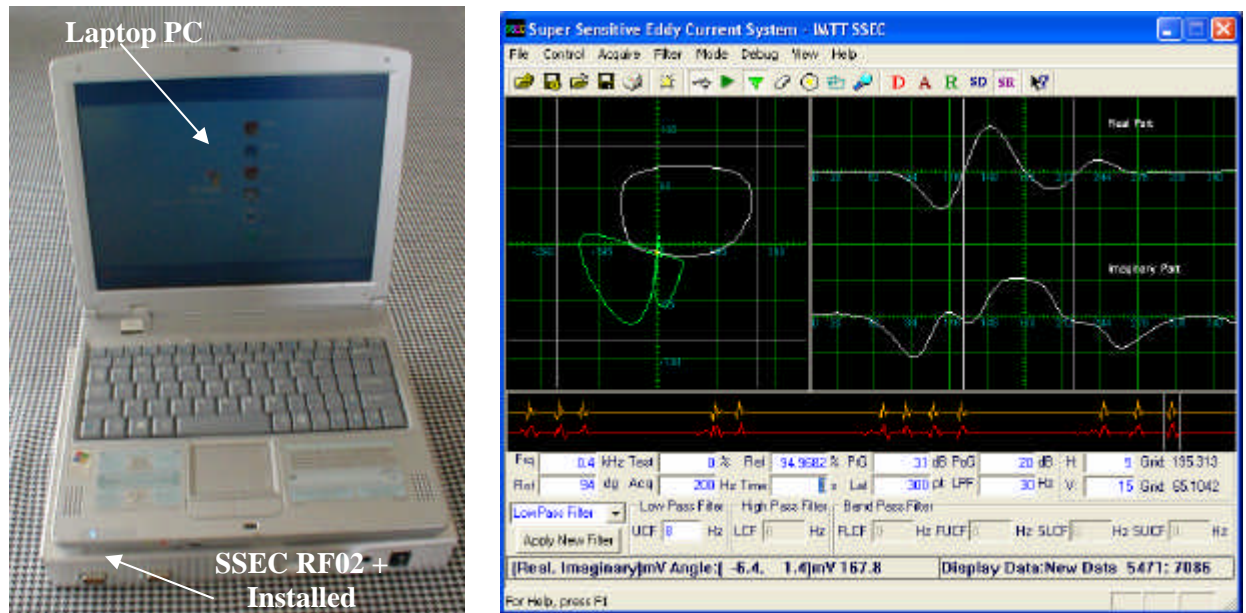

Figure 2: SSEC RF02 system with a laptop PC (left) and the System Screen (right).

Application No. 1: Detection of aluminum layer cracks through one and half inch of polycarbonate.

Specimens:

Three 7”×13” polycarbonate pieces of different thicknesses are used in this test. A 9.0”×1.25”×0.20” aluminum strip is attached to the bottom center area of each of the polycarbonate pieces using six titanium fasteners, 1.0” apart, as shown in Figure 3 A. Two though thickness EDM notches are made between fasteners No.2 & No. 3, No. 4 & No. 5 on each of the aluminum strips.

The numbering and the thicknesses of the three polycarbonate specimens are listed below:
 567-007: 0.567”; 0.484-007: 0.483” and 0.442-007: 0.442”.

Sliding probe RF4 V.3A scanning over different thicknesses of polycarbonate layers

At first an RF4 V.3A probe is placed on top of each specimen and scanning above the aluminum strip as shown in Figure 4. The thicknesses of the polycarbonate layers are 0.442”, 0.483” and 0.567”, respectively. To experimentally test the limits of the technology, we tried the inspection through two layers, Figure 3 B. This results in three more data for thicknesses of 0.925” (0.442” + 0.483”), 1.009” (0.442” + 0.567”) and 1.050” (0.483” + 0.567”). A signal magnitude – polycarbonate thickness related is shown in Figure 5.

We also tried scanning the probe over all the three layers, Figure 3 C. The total thickness is 1.492” (0.442” + 0.483” + 0.567”). The EDM signal is still clear as shown in Figure 6.

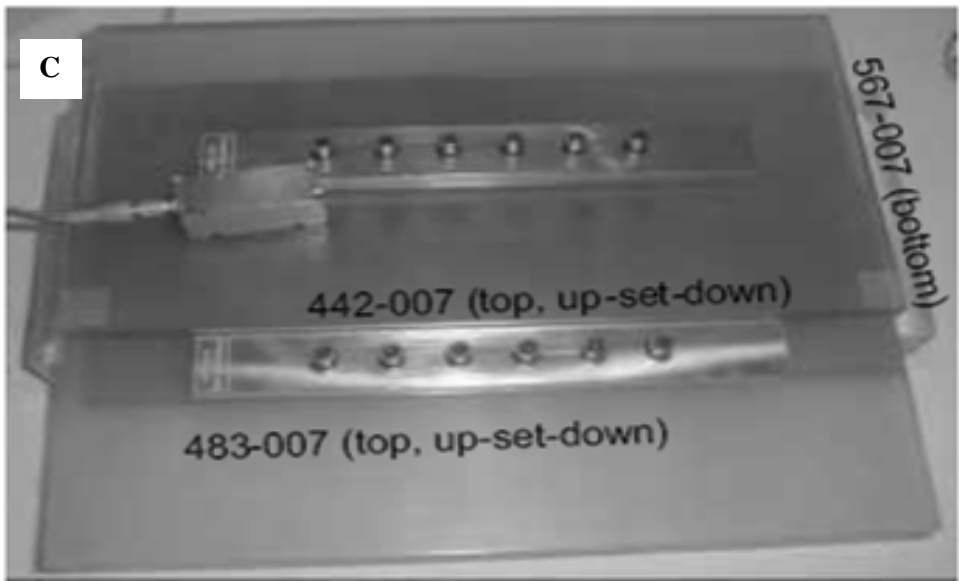
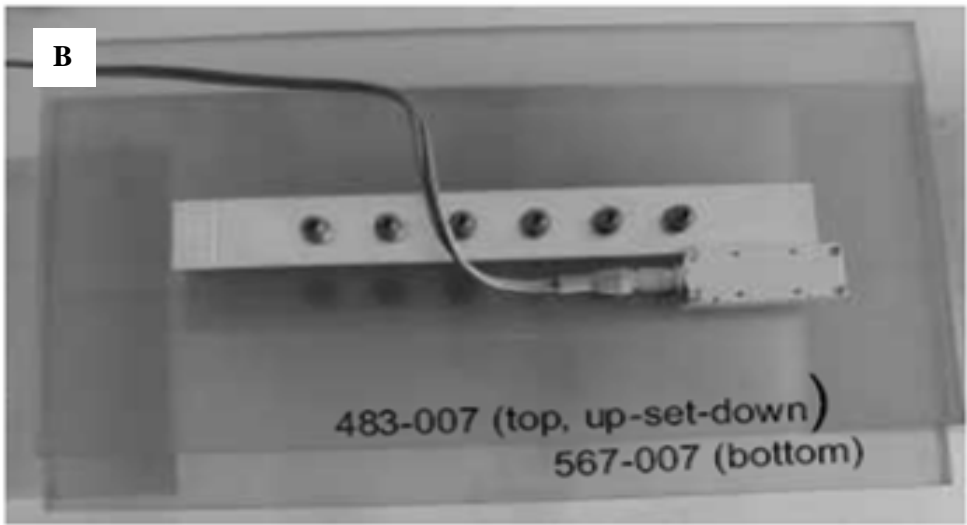
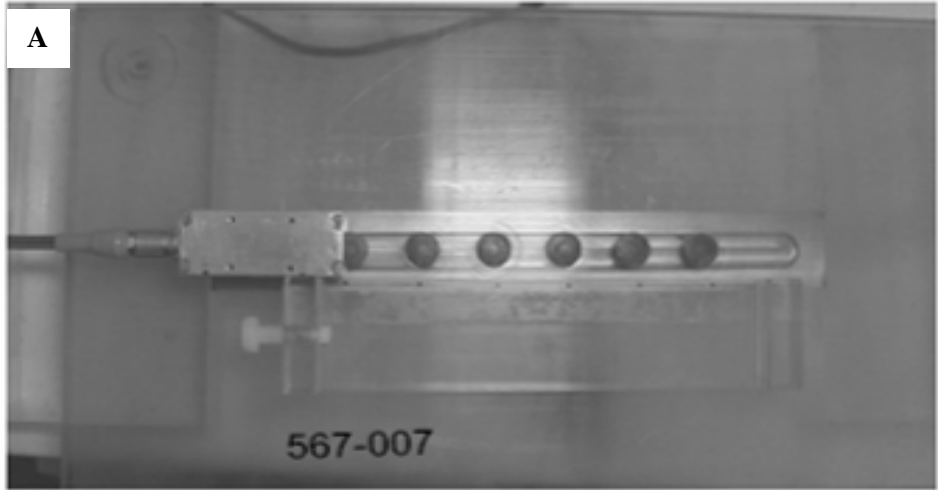

Figure 3: Specimens: A – single layer; B – Double layers; C – three layers.

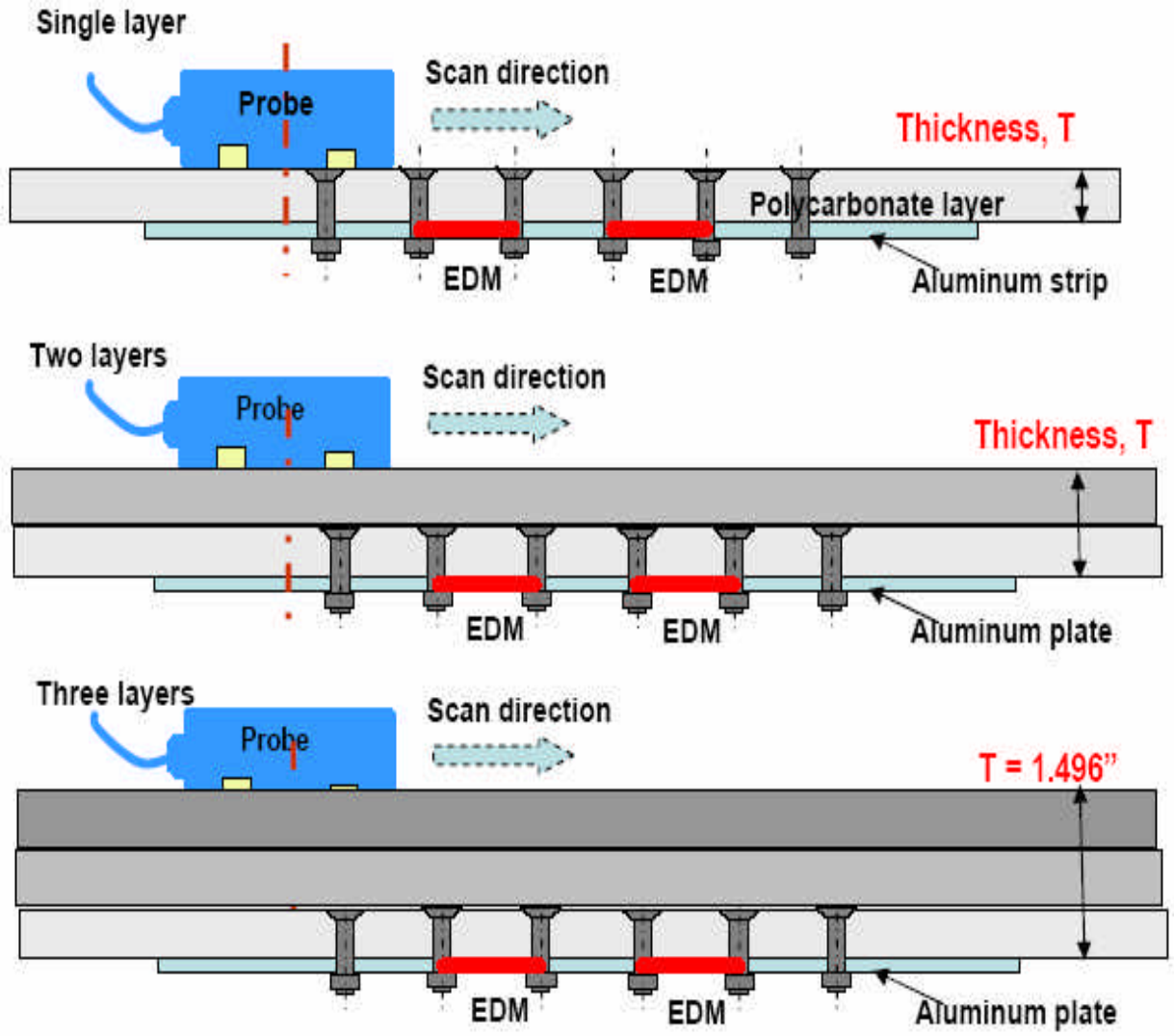
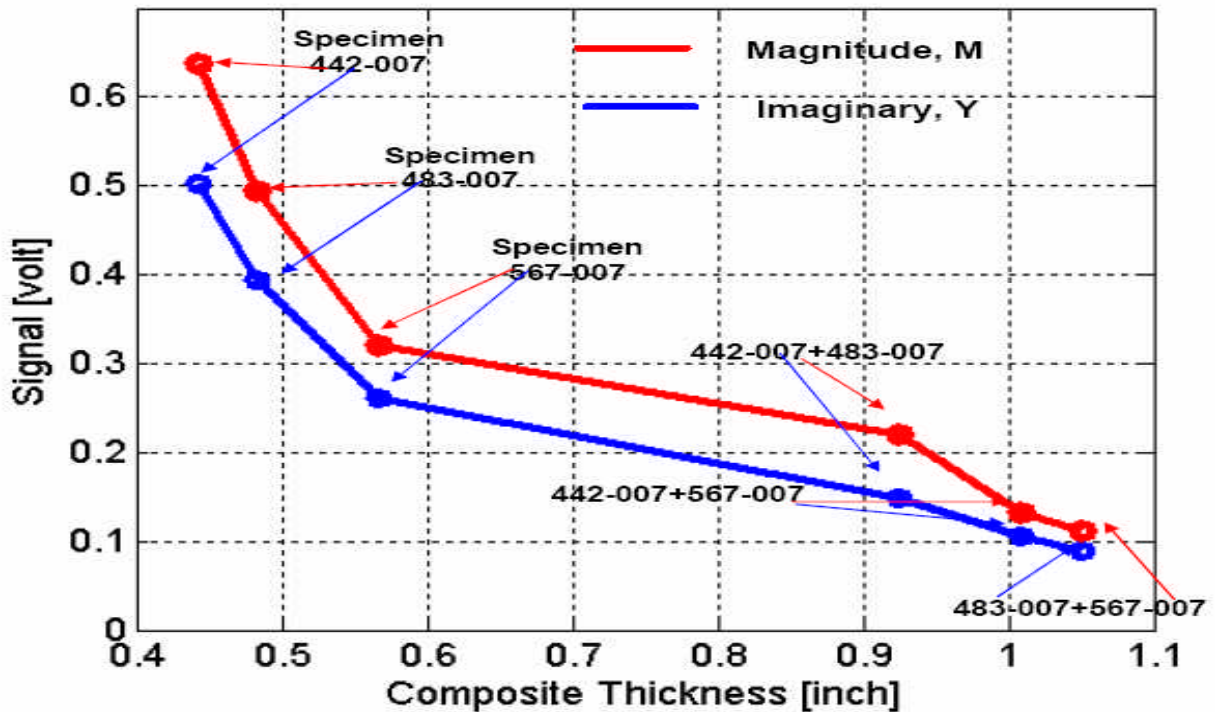

Figure 4: A RF4 V.3A is scanning along the center-line of a polycarbonate layer(s) directly above the aluminum strip

A Complete Signal – Thickness Relation Curve at $f = 2.0\text{kHz}$ Crack Signal vs Composite Thickness



Thickness [inch]		0.442	0.483	0.567	0.925	1.007	1.050
Imaginary	Signal [v]	0.5036	0.3941	0.2605	0.1478	0.1050	0.0896
	Noise [v]	0.130	0.115	0.085	0.030	0.015	0.027

Figure 5: Signal magnitude – Polycarbonate thickness relation at $f = 2.0\text{ kHz}$

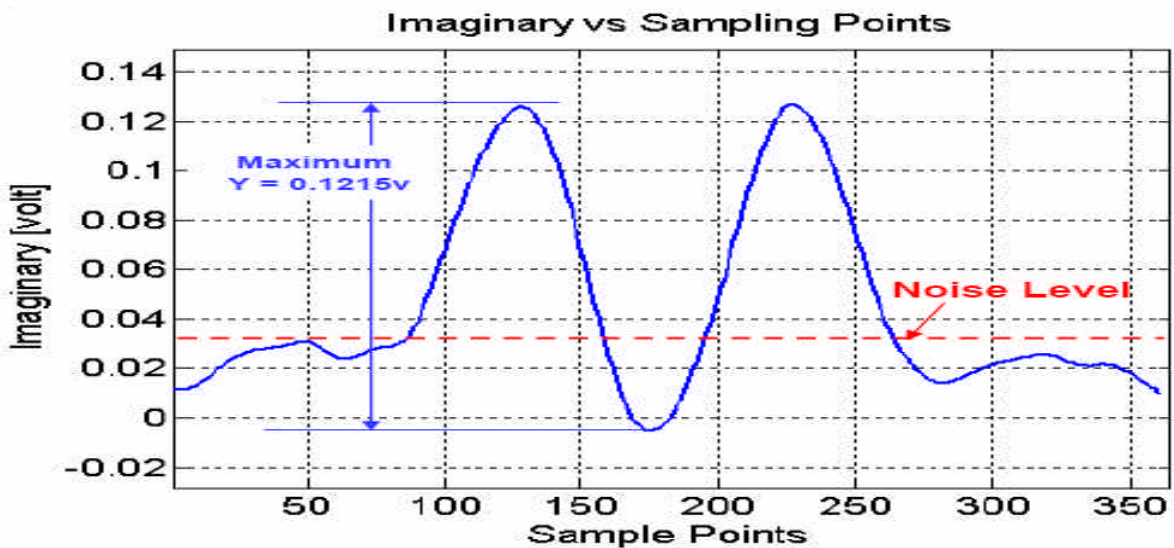

Figure 6: EDM signals obtained when scanning over all three layers with a total thickness of 1.492" at $f = 200\text{ Hz}$.

Application No. 2: Detection of aluminum layer cracks through thick graphite epoxy composite

Specimens:

Four 7"×13" graphite epoxy composite pieces of two thicknesses, 0.520" and 0.896", are used in this test. A 9.0"×1.25"×0.20" aluminum strip is attached to the bottom center area of each of the composite pieces using eight titanium fasteners, one inch apart, as shown in Figure 7 A. A number of though thickness EDM (electro-discharge machined) notches of different lengths and with horizontal and vertical orientations are made on each of the aluminum strips as shown on Figure 7.

Probe RF4 V.3A scanning over the four specimens

The four specimens were scanned using Probe RF4 V.3A. The test results are shown in Figure 8. Typical data compared with noise level are listed in Table 1.

Note: In the detection of deep flaws, signal magnitude and S/N ratio, may not make sense in identification of a crack. Phase angle, or signal orientation in impedance plane, some times plays a major role. We have seen in Figure 8 that signals from horizontal notches tend to be oriented in the first quadrant, while signal from vertical notches take directions around 180°.

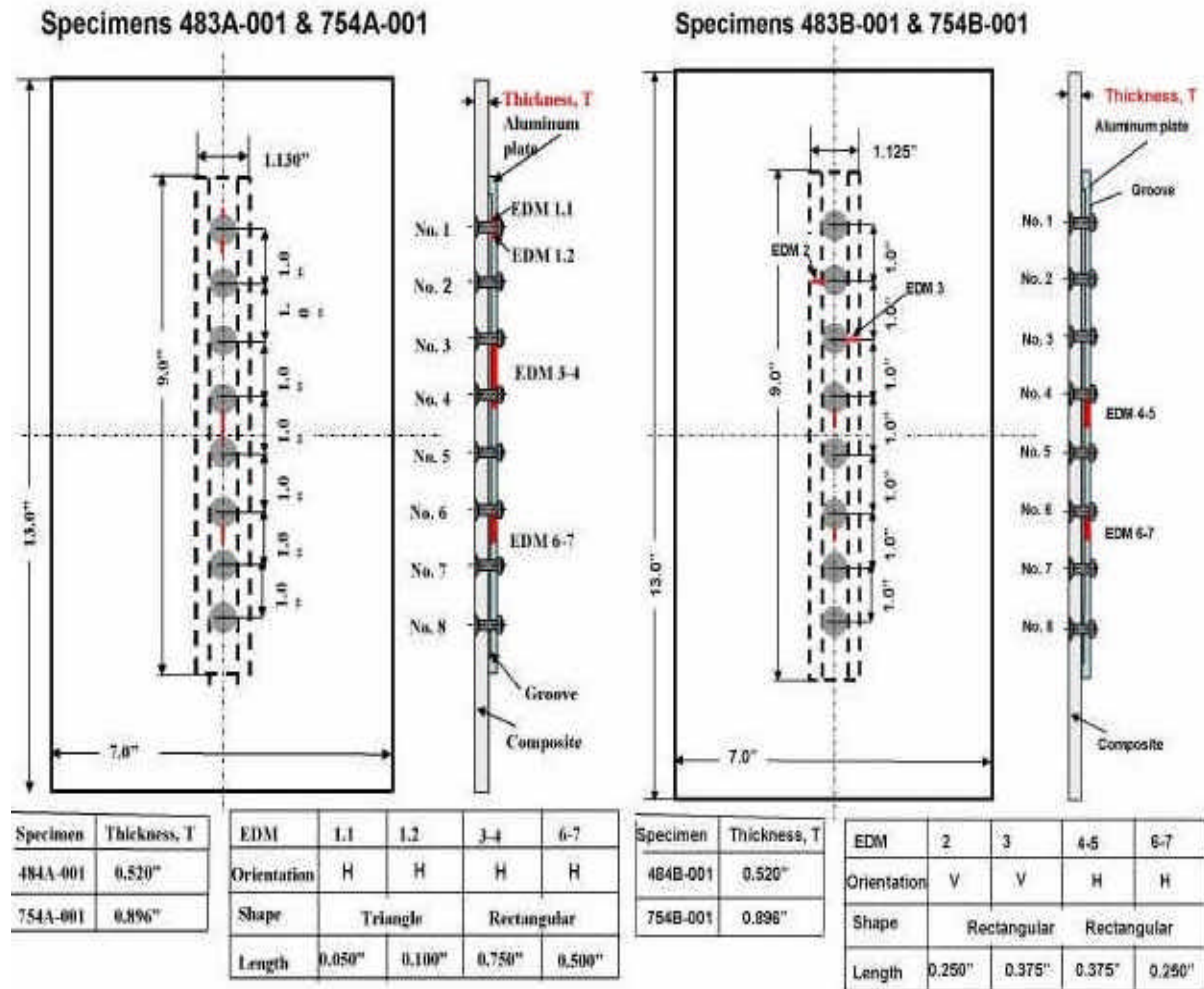
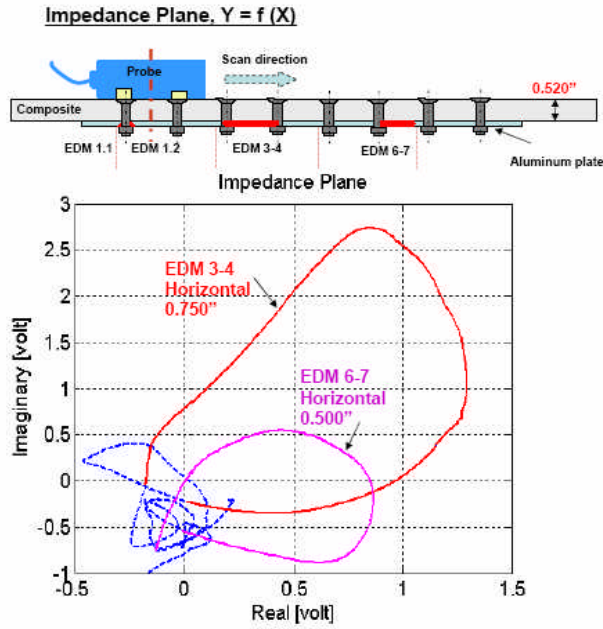

Figure 7: Two drawings showing four specimens with thick graphite epoxy composite layer

Test Results (1) – 483A-001

Crack Signals – Processed



Test Results (2) – 754A-001

Crack Signals – Processed

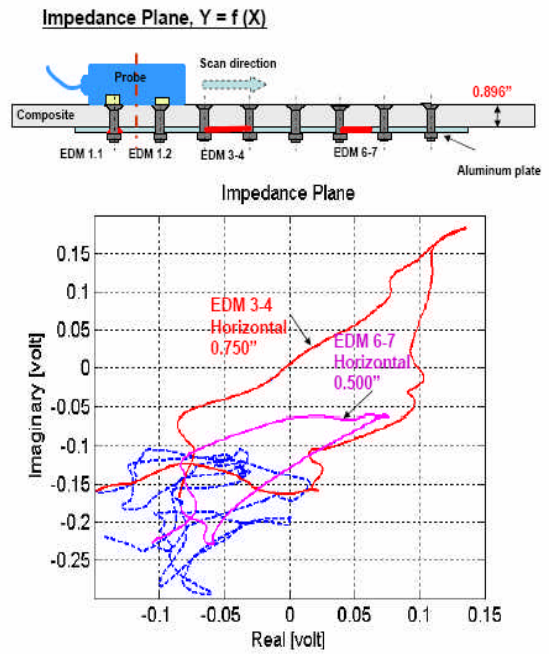

Test Results (3) – 483B-001

Crack Signals – Processed

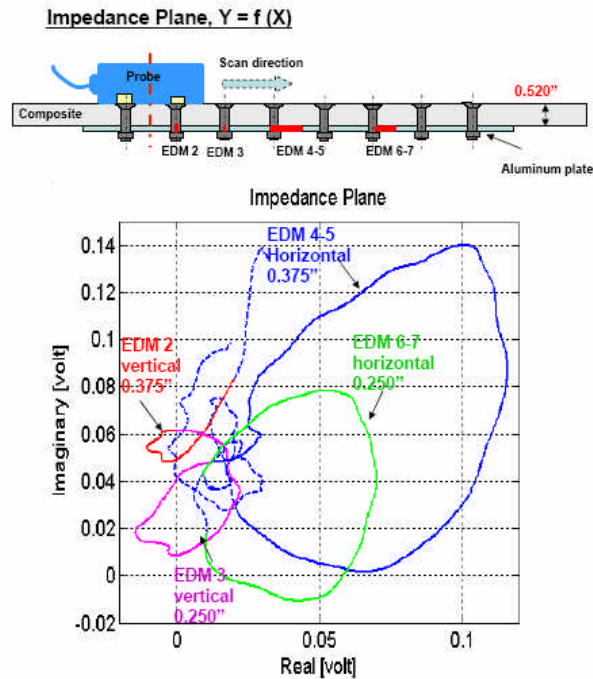

Test Results (4) – 754B-001

Crack Signals – Processed

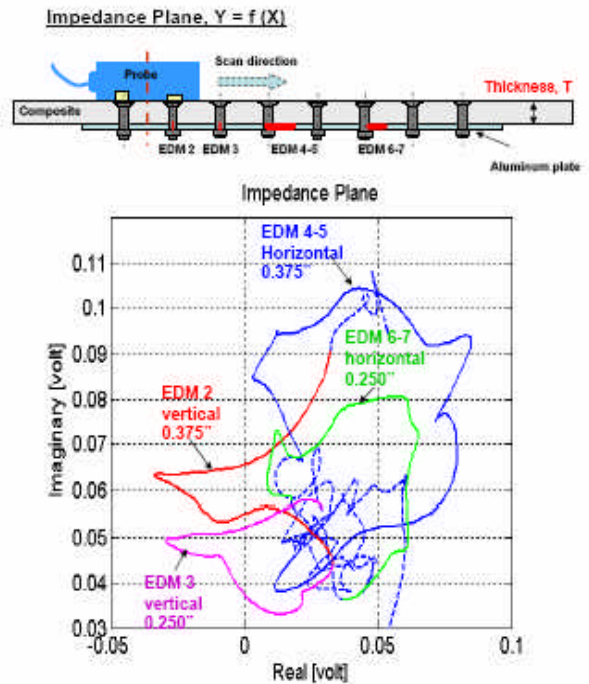

Figure 8: Impedance Planes obtained from scanning the four composite specimens

Table 1: Typical Data Taken from the Curves in Figure 8

Specimen #		483A(0.52")	754A(0.896")	483B(0.52")	754B(0.896")
EDM description					
Horizontal 0.750" EDM	Real [v]	1.76	0.275		
	Noise [v]	0.46	0.100		
	Imaginary [v]	3.43	0.410		
Horizontal 0.500" EDM	Noise [v]	0.79	0.110		
	Real [v]	1.10	0.180		
	Noise [v]	0.46	0.100		
Horizontal 0.375 EDM	Imaginary [v]	1.39	0.180		
	Noise [v]	0.79	0.110		
	Real [v]			0.140	0.079
Horizontal 0.250" EDM	Noise [v]			0.038	0.036
	Imaginary [v]			0.138	0.068
	Noise [v]			0.045	0.0238
	Real [v]			0.0638	0.055
Vertical 0.375"	Noise [v]			0.045	0.036
	Imaginary [v]			0.0914	0.0346
	Noise [v]			0.038	0.0238
Vertical 0.250"	Real [v]			0.035	0.058
	Noise [v]			0.038	0.0238
Vertical 0.250"	Real [v]			0.038	0.060
	Noise [v]			0.038	0.0238

Application No. 3: Detection of titanium layer cracks through thick graphite epoxy composite

Specimens¹:

Three, 0.25" thick titanium plates (see Figure 9) with fatigue cracks of different lengths, 0.250", 0.500" and 0.750", respectively, combined with three graphite epoxy composite plate of different thickness, 0.250", 0.333" and 0.500", result in a matrix of nine specimens as shown in Table 2. A 5/16" titanium fastener is used to tie a composite layer and a titanium plate together.

Rotational probe RF4 ROT scanning around the fastener of each specimen

All cracks in the nine specimens are detected with significantly high S/N ratio. A typical crack signal in the impedance plane, provided detection at the smallest crack length, 0.25", and the largest composite thickness, 0.500", is shown in Figure 10 A.

Summaries of the test results are in Table 1, in a text format, and in Figure 10 B, using curves.

¹ Specimens are provided by US Air Force Research Laboratory.

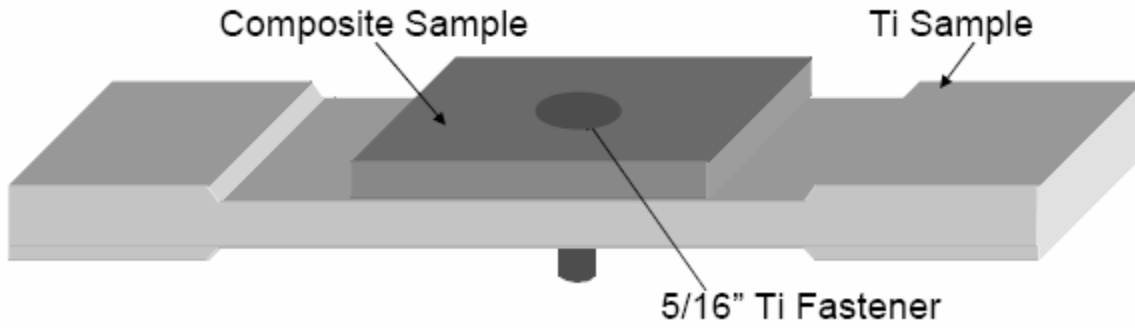

Figure 9: Typical configuration of a test specimen

Table 2
Summary of Test Results (1)

Titanium Sample # / Composite Sample #	# 2 Thickness = 0.250"	# 3 Thickness = 0.334"	# 4 Thickness = 0.500"
# 1 Crack Length = 0.25"	Magn. = 0.138 v Ph. = 55.2°	Magn. = 0.074 v Ph. = 57.0°	Magn. = 0.050 v Ph. = 61.5°
# 2 Crack Length = 0.50"	Magn. = 0.242 v Ph. = 63.4°	Magn. = 0.122 v Ph. = 59.1°	Magn. = 0.036 v Ph. = 63.7°
# 3 Crack Length = 0.75"	Magn. = 0.281 v Ph. = 55.8°	Magn. = 0.139 v Ph. = 52.1°	Magn. = 0.043 v Ph. = 60.5°

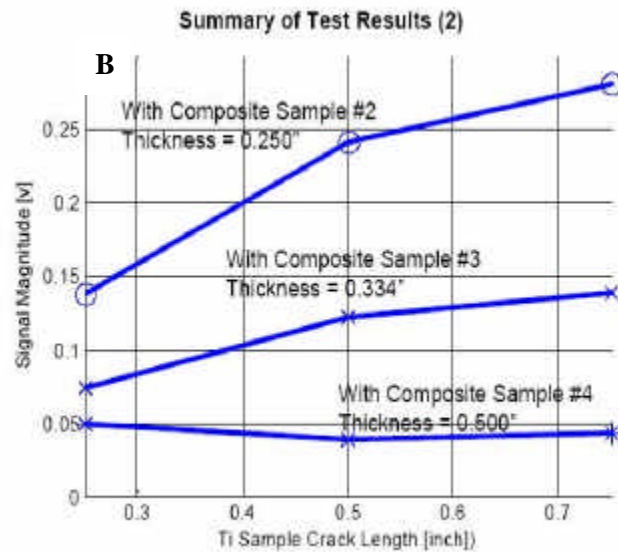
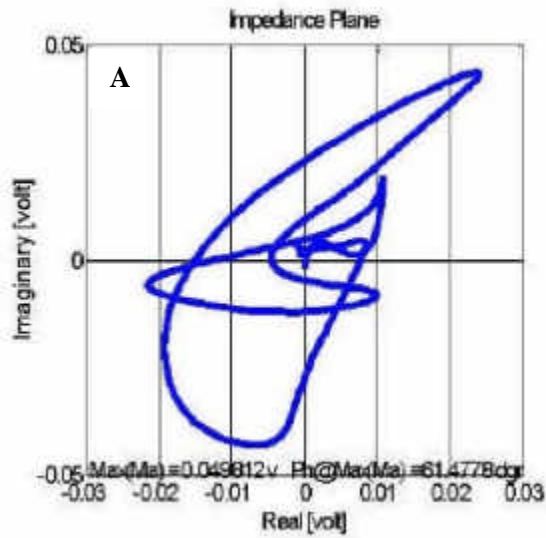

Figure 10: Impedance plane at 0.25" crack & 0.50" thick composite (A) & Summary of test results on detecting titanium layer cracks through graphic epoxy components (B)

Application No. 4: Detection of cracks on titanium layer through thick graphite epoxy composite and suppression of sealant groove signals

Specimens²:

A 0.500" long fatigue crack is generated from the center hole of a piece of 0.25" thick titanium plate. Two sealant grooves of different orientations are made on the two sides of the plate, one side each, Figure 11.

Rotational probe RF4 ROT scanning around the fastener of each side of the specimen

Figure 12 shows the configuration of the scan. A special band-pass filter is used to minimize the signals generated by the sealant groove. Typical signals detected from the two scans are shown in Figure 13. It is clearly seen that the groove signals have been effectively suppressed.

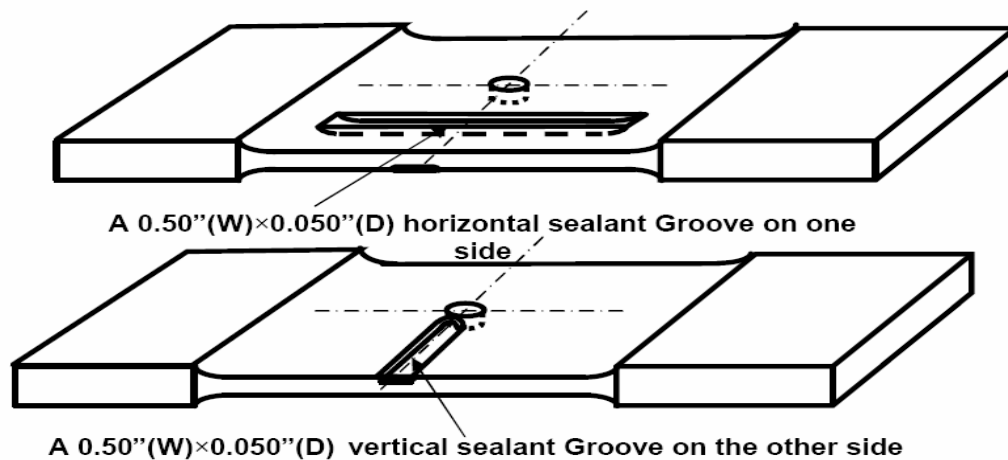

Figure 11: Titanium plate with a fatigue crack and two sealant grooves, one side each

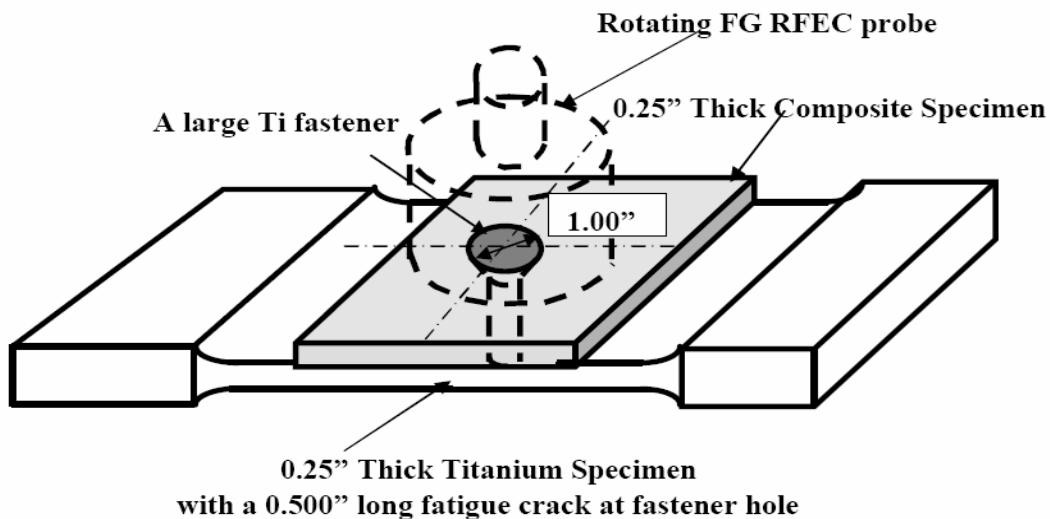

Figure 12: A Rotational probe RF4 Rot is used to detect the 0.500" crack in the titanium plate. A band-pass filter is used to suppress the signals from the sealant grooves

² Specimens are provided by US Air Force Research Laboratory.

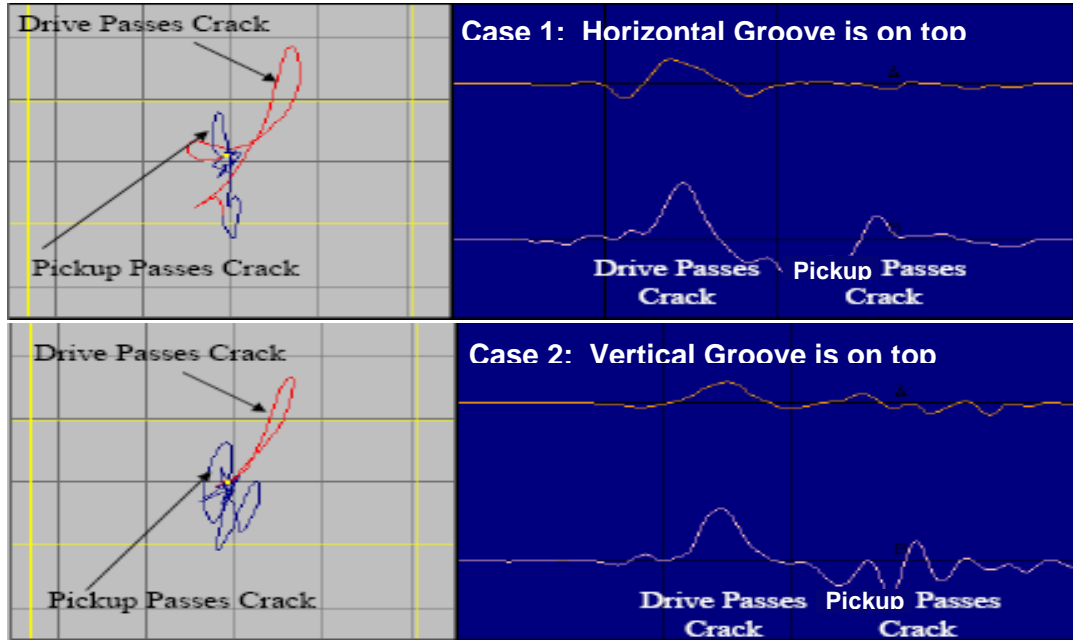

Figure 13: Groove signals have been effectively suppressed by a band-pass filter. The two left plots are impedance planes. The upper curve in each of the two right plots is the real component of the signal, the lower curve is the imaginary of the signal.

Application No. 5: Detection of crack 0.50” below aluminum structure surface

Specimen³:

A drawing of the specimen is shown in Figure 14. It is a two layer aluminum structure with a 0.200” long EDM notch generated from a fastener hole of the second layer. The thickness of the first aluminum layer is 0.500”.

Rotational probe RF4 ROT scanning around a fastener without an EDM notch and another fastener with a 0.200”long EDM notch

The impedance planes obtained from the two scans are shown in Figure 15. The crack signal is distinguished from the edge effect signal primarily by its shape instead of signal magnitude.

Note: In the detection of deep flaws, signal magnitude and S/N ratio, may not make sense in identification of a crack. Phase angle, or signal orientation/shape in impedance plane, some times plays a major role. Comparison of an unknown signal with a known cracked or no-crack signal may be a good way to identify a crack. We have seen in Figure 15 the lower portion of the cracked signal, in green, has a similar shape as the no-crack signal. The upper portion of the cracked signal, in white, is considerably different from the no-crack signal. In other words, in the crack signal there is a significant part of the signal appearing in the first quadrant of the impedance plane and significant positive real and positive imaginary appearing in the X & Y strip charts.

³ Specimen is simulating Canadian aircraft CC130. It was provided by Captain D.J. Butcher, Canadian Air Force.

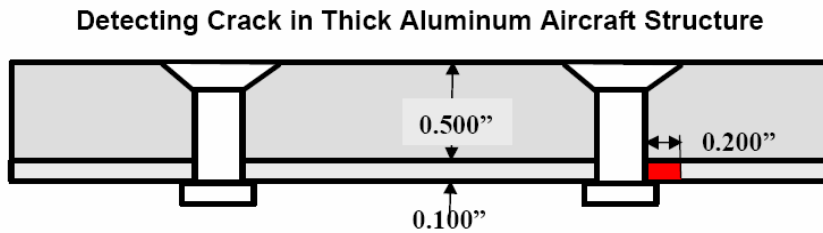

Figure 14: A specimen simulating 2nd layer crack in CC130 structure

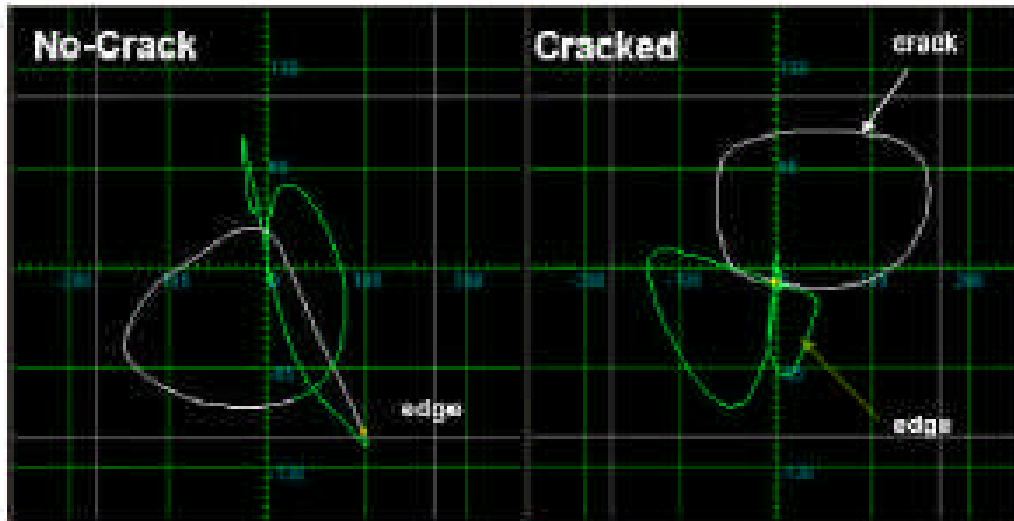

Figure 15: Detected crack signal, right, compared with no-crack signal, left

Application No. 6: Detection of fine surface and subsurface cracking on curved steel surface of Airbus A-320 landing gear structure

Specimen⁴:

The specimen was a part removed from a retired Airbus A-320 landing gear, Figure 16. The surface is of complex shape where it is difficult to apply a sliding probe for crack detection. A pencil probe is the one applicable here, but the detection suffers from tremendous noise cause by hand shaking of an operator.

⁴ Specimen is provided by Northwest Airlines.

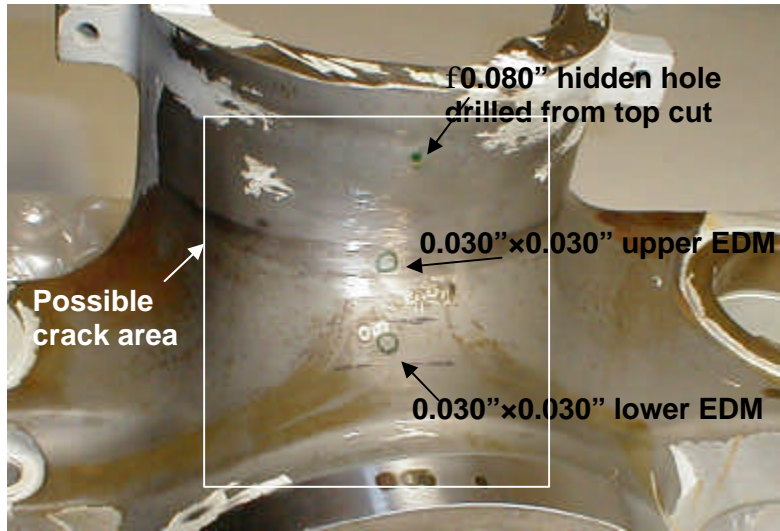

Figure 16: Specimen cut from Airbus A-320 landing gear with two 0.030'' (L) × 0.030'' (D) EDM notches and a φ0.080'' hidden hole on its curved surface

Sliding probe RF2 V.3 with a specially designed probe holder, Figure 17 A & B, used in scanning the curved surface

The relative probe-holder position is adjustable. During a scan first to keep the sensitivity surface of the probe having a good a contact with the surface under inspection. Then, adjust the probe holder position to have at least one or two tips of the holder contacting the surface under inspection as well. After that the probe can be moved smoothly along the surface within a certain distance, see Figure 17 C.

The detected crack signals and the signal from the hidden hole are shown in Figure 18-20.

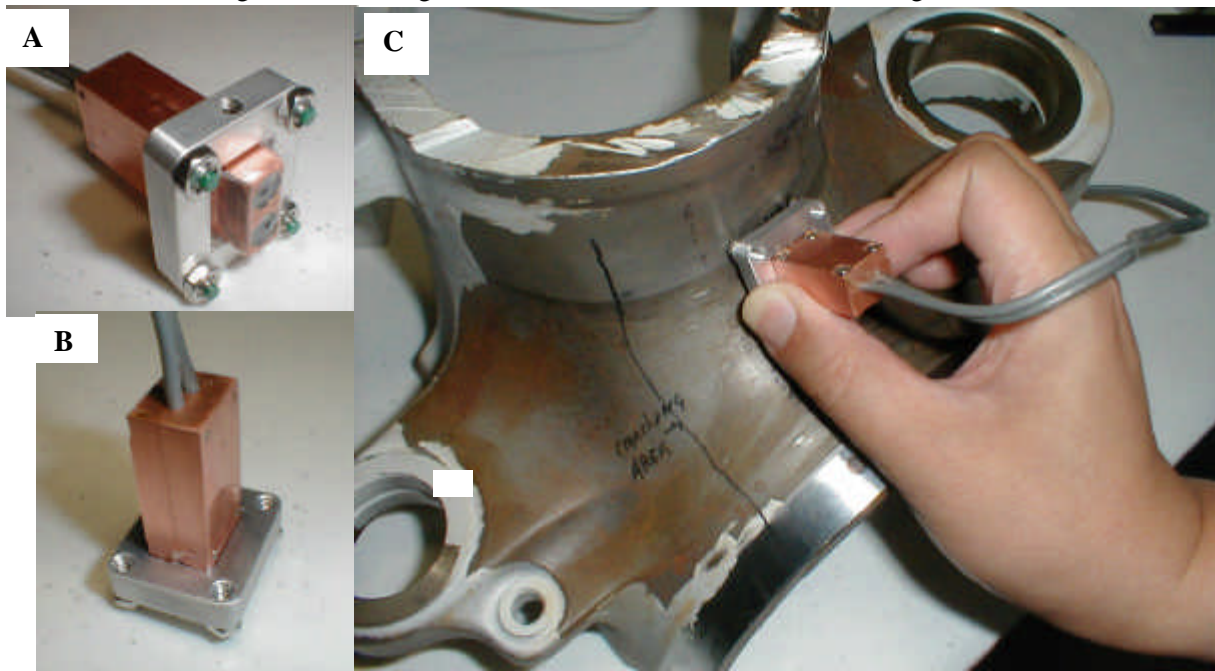

Figure 17: Probe RF2 V.3 working with a specially designed probe holder scanning the curved surface of the A-320 landing gear specimen

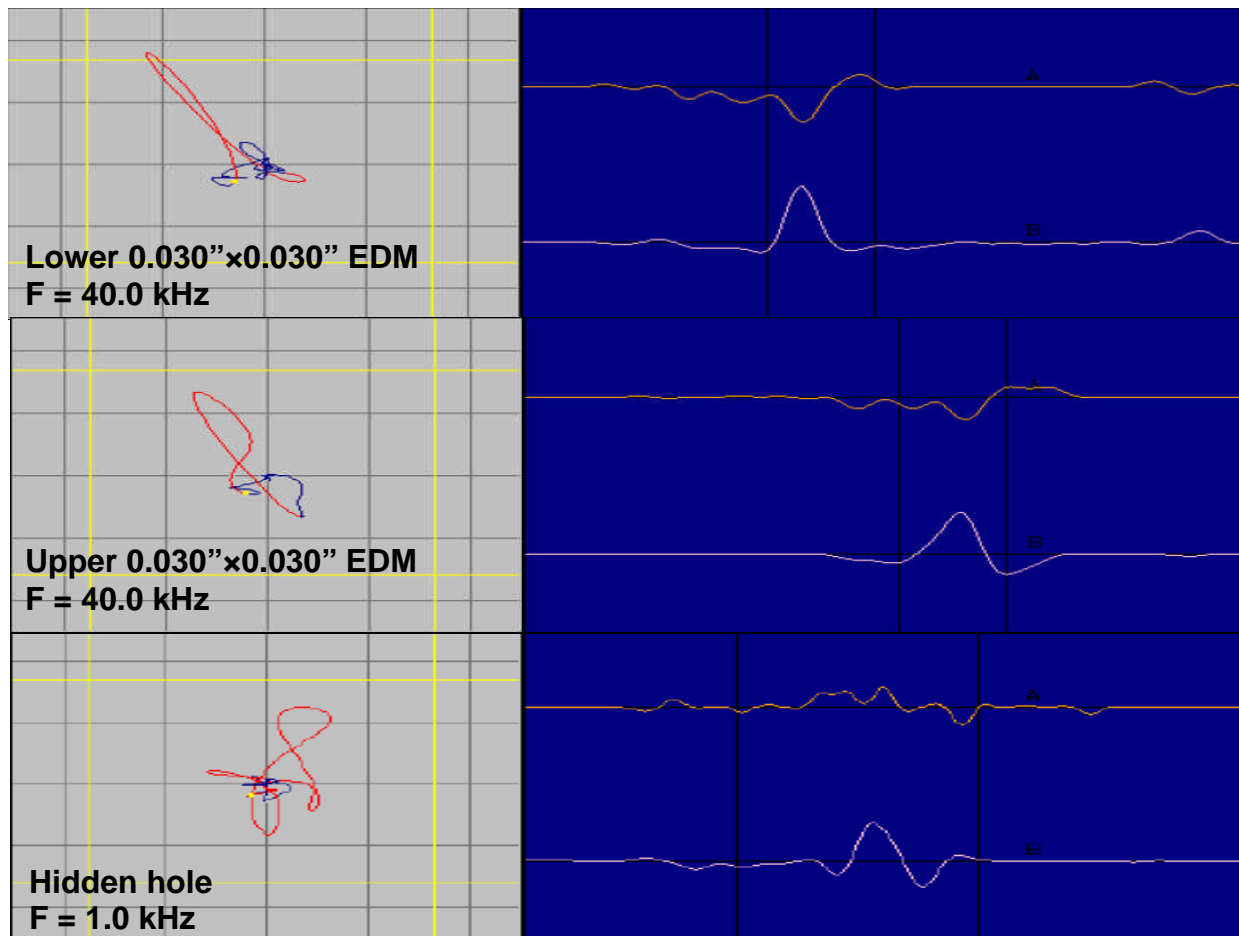

Figure 18: Signals obtained from the surface cracks and hidden holes

Summary

1. Metallic layer cracks underneath thick composite layer are detectable using FG_RFEC technique – sliding probes or rotational probes;
2. A groove signal can be effectively suppressed using a band-pass filter;
3. FG_RFEC technique working with SSEC system is capable of detecting deeply hidden cracks and fine surface and subsurface cracking with high sensitivity.
4. The next step is to assess existing or new inspections, now available to our industry, to find the right fit and application of this advanced technology.

Acknowledgements

The authors would like to express their appreciation and great thanks to Jeff A. Register and Michael J, Fortman, Northwest Airlines⁵, and Captain D. J. Butcher, Canadian Air Force, for their providing test samples, test requirements and comments to IMTT.

The authors would like also to express their appreciation and great thanks to Dr. Ward D. Rummel, D&W Enterprises, LTD, for his careful view and valuable comments to this paper.

⁵ Jeff A. Register and Michael J, Fortman were with Northwest Airlines when they were involved in the work, Application No. 6, stated in this paper. Now they are working with Aerotechnics NDT, Inc.

References:

- [1]. Y. Sun, S. Udpa, W. Lord and D. Cooley, "A Remote Field Eddy Current NDT Probe for the Inspection of Metallic Plates", published on Topical Conference Paper Summaries Book - ASNT's International Chemical and Petroleum Industry Inspection Technology (ICPIIT) IV Topical Conference, 1995.
- [2]. Y.S. Sun, S. Udpa, W. Lord, and D. Cooley, "A Remote Field Eddy Current Probe for the Inspection of Metallic Plates", *Materials Evaluation*, Vol. 54, No. 4, PP. 510-512, April 1996.
- [3]. Y.S. Sun, W. Lord, L. Udpa, S. Udpa, S.K. Lua, K.H. Hg, and N. Nath, "Expanding The Remote Field Eddy Current Techniques To Thick - Walled Aluminum Plate Inspection", *Electromagnetic Nondestructive Evaluation - Studies in Applied Electromagnetics and mechanics 12*, pp.145-152, Edited by T. Takagi, et al., IOS Press, 1997.
- [4]. Yu-shi Sun, US Patent 6,002,251, "Electromagnetic-Field-Focusing Remote-Field Eddy-Current Probe System and Method for Inspecting Anomalies in Conducting Plates", Issue date: 12/14/1999.
- [5]. Yushi Sun and Tianhe Ouyang, "Detection Of Cracks In Multi-Layer Aircraft Structures With Fasteners Using Remote Field Eddy Current Method", *Proceeding of SPIE Volume 3994, Nondestructive Evaluation of Aging Aircraft, Airports, and Aerospace Hardware IV*, Chair/Editor Ajit K. Mal, 7-8 March 2000, Newport Beach, CA.
- [6]. Yushi Sun, Tianhe Ouyang, and Satish Udpa, "Multi-Layer Aircraft Structure Inspection Using A Ultra-Sensitive Remote-Field Eddy-Current System", *Review of Progress in Quantitative Nondestructive Evaluation*, Vol. 20, Plenum, 2001.
- [7]. Yushi Sun, Tianhe Ouyang, and Robert J. Lord, "Detecting 1st and 2nd Layer Simulated Cracks in Aircraft Wing Spanwise Splice Standards Using Remote-Field Eddy Current Technique", *Proceedings of Aging Aircraft Conference 2001*, Kissimmee, Florida, September 10~13, 2001.
- [8]. Yushi Sun, et al., "Building Calibration Standard Remote Filed Eddy Current Technique Detecting Deeply Hidden Corrosion in Aircraft Structures", 5th International Aircraft Corrosion Workshop Proceedings, Solomons, MA, August 20-23, 2002.
- [9]. Yushi Sun & Cu Nguyen, "A Highly Sensitive System For Aircraft Crack Detection – The Rotational Remote Field Eddy Current Probe And Super Sensitive Eddy Current System", Presented at The 46th Annual NDT Forum, Montreal, QC, Canada, September 22 -25, 2003.
- [10]. Yushi Sun, Tianhe Ouyang, Jie Long, Denis Roach "Rotational Remote-Field Eddy Current Method For Detecting Cracks Under Raised Head Fasteners", Presented at The 7th FAA/DoD/NASA Joint Conference on Aging Aircraft, New Orleans, LA, September 7-11, 2003.
- [11]. Yushi Sun, Tianhe Ouyang, Jie Long, Jeff Thompson, Jeff Kollgaard, "Detecting Cracks Under Bushings With Rotational Remote-Field Eddy Current Probes", Presented at The 7th FAA/DoD/NASA Joint Conference on Aging Aircraft, New Orleans, LA, September 7-11, 2003.
- [12]. Yushi Sun, Harry Zhu, Tom Moran, John C. Brausch, Kenneth J. LaCivita, Anderson Danny, Thomsen Mark, Lisa Brasche, and Michael Harper, "Detecting Cracks under Bushings in Aircraft Structures Using FG RFEC & SSEC Technique", Presented at ASIP 2004 Conference held in Memphis, TN, November 29 – December 2, 2004.
- [13]. Yushi Sun, Dennis Roach, Harry Zhu, "New Advances in Detecting Cracks in Raised-Head Fastener Holes Using Rotational Remote Field Eddy Current Technique", Presented at 2005 ASNT Fall Conference held in Columbus, OH, October 17-21, 2005.