

# **EFFECT OF AC POWER ON EBW DETONATORS**

Allan H. Herrbach

U.S. Department of Energy  
Kirtland Area Office  
Albuquerque, NM

## **ABSTRACT**

Modern LASL detonators were subjected to three alternating current waveforms to determine the susceptibility of the detonators to high-order detonations when the line voltages supplied by local utility companies are applied across the detonator electrodes. Dent blocks were used for each test to resolve whether a high-order detonation was obtained. Some of the detonators were confined in mock H. E. inserts to compare the performance of a confined detonator with that of an unconfined detonator. The 1E30, 1E31, 1E33, and SE-1N detonators were investigated in three voltage waveforms, nominally 110, 208, and 440 V. None of these detonators achieved a high order detonation on any of the waveforms. The detonators either deflagrated or failed. The statistical probability, derived from the test results, of attaining a deflagration when one of these detonators is "plugged into" a wall outlet at any of the waveforms was between 70 and 85%.

## **INTRODUCTION**

Modern LASL detonators were subjected to three alternating current waveforms to determine the susceptibility of the detonators to high-order detonations when the line voltages supplied by local utility companies are applied across the detonator electrodes. This project was result of previous 60-Hz, 110 V a.c. tests made by J. C. Anderson of LASL and the Test Fire Group at Mound Facility. Since Mound had developed a system to test detonators using 60-Hz line voltage, LASL requested Mound to test their modern detonators using this system.

Concern for safety in handling modern detonators was the primary incentive for conducting alternating current voltage tests on the detonators. The 1E30, 1E31, 1E33, and SE-1N were tested. Three alternating current voltage waveforms were used: the nominal 110, 208, and 440 V waveforms. There was concern that confined detonators would perform differently from unconfined, so each detonator type was fired in both confined and unconfined configurations.

## **FIRING SYSTEM**

The firing cycle was initiated by a manual switch which was normally closed. Firing circuit design was such that a negative half-cycle must occur before the firing circuit was gated. Therefore, a firing pulse was not initiated until a negative half-cycle had been completed. As the 60-Hz waveform passed from negative to positive polarity (zero crossover, see Figure

# Report Documentation Page

Form Approved  
OMB No. 0704-0188

Public reporting burden for the collection of information is estimated to average 1 hour per response, including the time for reviewing instructions, searching existing data sources, gathering and maintaining the data needed, and completing and reviewing the collection of information. Send comments regarding this burden estimate or any other aspect of this collection of information, including suggestions for reducing this burden, to Washington Headquarters Services, Directorate for Information Operations and Reports, 1215 Jefferson Davis Highway, Suite 1204, Arlington VA 22202-4302. Respondents should be aware that notwithstanding any other provision of law, no person shall be subject to a penalty for failing to comply with a collection of information if it does not display a currently valid OMB control number.

1. REPORT DATE <b>AUG 1994</b>		2. REPORT TYPE		3. DATES COVERED <b>00-00-1994 to 00-00-1994</b>	
4. TITLE AND SUBTITLE <b>Effect of AC Power on EBW Detonators</b>				5a. CONTRACT NUMBER	
				5b. GRANT NUMBER	
				5c. PROGRAM ELEMENT NUMBER	
6. AUTHOR(S)				5d. PROJECT NUMBER	
				5e. TASK NUMBER	
				5f. WORK UNIT NUMBER	
7. PERFORMING ORGANIZATION NAME(S) AND ADDRESS(ES) <b>U.S. Department of Energy, Kirtland Area Office, PO Box 5400, Albuquerque, NM, 87185-5400</b>				8. PERFORMING ORGANIZATION REPORT NUMBER	
9. SPONSORING/MONITORING AGENCY NAME(S) AND ADDRESS(ES)				10. SPONSOR/MONITOR'S ACRONYM(S)	
				11. SPONSOR/MONITOR'S REPORT NUMBER(S)	
12. DISTRIBUTION/AVAILABILITY STATEMENT <b>Approved for public release; distribution unlimited</b>					
13. SUPPLEMENTARY NOTES <b>See also ADM000767. Proceedings of the Twenty-Sixth DoD Explosives Safety Seminar Held in Miami, FL on 16-18 August 1994.</b>					
14. ABSTRACT <b>see report</b>					
15. SUBJECT TERMS					
16. SECURITY CLASSIFICATION OF:			17. LIMITATION OF ABSTRACT <b>Same as Report (SAR)</b>	18. NUMBER OF PAGES <b>23</b>	19a. NAME OF RESPONSIBLE PERSON
a. REPORT <b>unclassified</b>	b. ABSTRACT <b>unclassified</b>	c. THIS PAGE <b>unclassified</b>			

1) a pulse was initiated which started a time-interval counter and triggered a second pulse generator. This second generator had a variable pulse width which was controlled by a variable resistor. The function of the second generator was to vary the time from zero crossover to the silicon-controlled rectifier (SCR) closure and detonator firing (see Figure 1). Thus, varying the pulse width changed the position on the voltage waveform at which the SCR was triggered. SCR closure was accomplished by sensing the trailing edge of the variable pulse.

**Figure 1. Firing System Test Using Only Positive Half cycle 60-Hz Line Power**

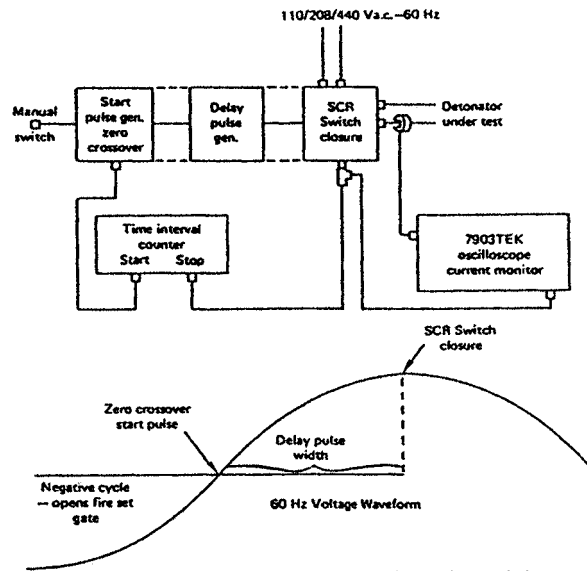

FIGURE 1 - Firing system test using only positive half cycle, 60-Hz line power.

The third and final pulse stopped the time-interval counter, triggered the current monitoring oscilloscope, and started the SCR trigger circuit. Counter display was used to adjust the variable pulse width. Because of the coarseness of the variable resistor in the delay generator circuit (see Figure 2), time increments (from zero crossover to SCR closure) below 0.20 msec were restricted. The firing circuit, shown in Figure 3 will be modified to overcome this restraint before further testing is done.

Figure 2. - 110, 208, and 440 V a.c. - 60-Hz Firing System

- |  |  |
|--|--|
| Q <sub>1</sub> , D <sub>3</sub> , D <sub>6</sub> - IN4004                        | C <sub>1</sub> - 0.47 μFd at 200 Vd.c.   |
| Q <sub>2</sub> , D <sub>4</sub> , D <sub>5</sub> - IN914B                        | C <sub>2</sub> - 500 μFd at 100 Vd.c.  |
|  | C <sub>3</sub> - 0.1 μFd at 18 Vd.c.   |
|  | C <sub>4</sub> - 0.05 μFd at 100 Vd.c.   |
|  | C <sub>5</sub> - 0.01 μFd at 200 Vd.c.   |
|  | C <sub>6</sub> - 0.47 μFd at 400 Vd.c.   |
| R <sub>1</sub> 47kΩ - 1/2W   | Q <sub>1</sub> , Q <sub>2</sub> , Q <sub>3</sub> , Q <sub>4</sub> , Q <sub>5</sub> , Q <sub>6</sub> - 2N3706 |
| R <sub>2</sub> 47kΩ - 1/4W   | Q <sub>4</sub> - 2N4401  |
| R <sub>3</sub> , R <sub>5</sub> 22kΩ - 1/4W                                      | Q <sub>7</sub> - 2N3900  |
| R <sub>6</sub> , R <sub>7</sub> , R <sub>10</sub> , R <sub>12</sub> 5.6kΩ - 1/4W | SCR <sub>1</sub> - MCR 2605  |
| R <sub>8</sub> 470Ω - 1/4W   | SCR <sub>2</sub> - MCR 470-80  |
| R <sub>9</sub> 1.8kΩ - 1/4W  |  |
| R <sub>11</sub> 220Ω - 1/4W  |  |
| R <sub>14</sub> 33kΩ - 1/4W  |  |
| R <sub>15</sub> 220Ω - 1/4W  |  |
| R <sub>16</sub> 2.2kΩ - 1/4W   |  |
| R <sub>17</sub> 3.9kΩ - 1/4W   |  |
| R <sub>18</sub> 10Ω - 1/4W   |  |
| R <sub>19</sub> 27Ω - 1/2W   | T <sub>1</sub> - Powder Designs<br>Pacific - Cat. 256  |

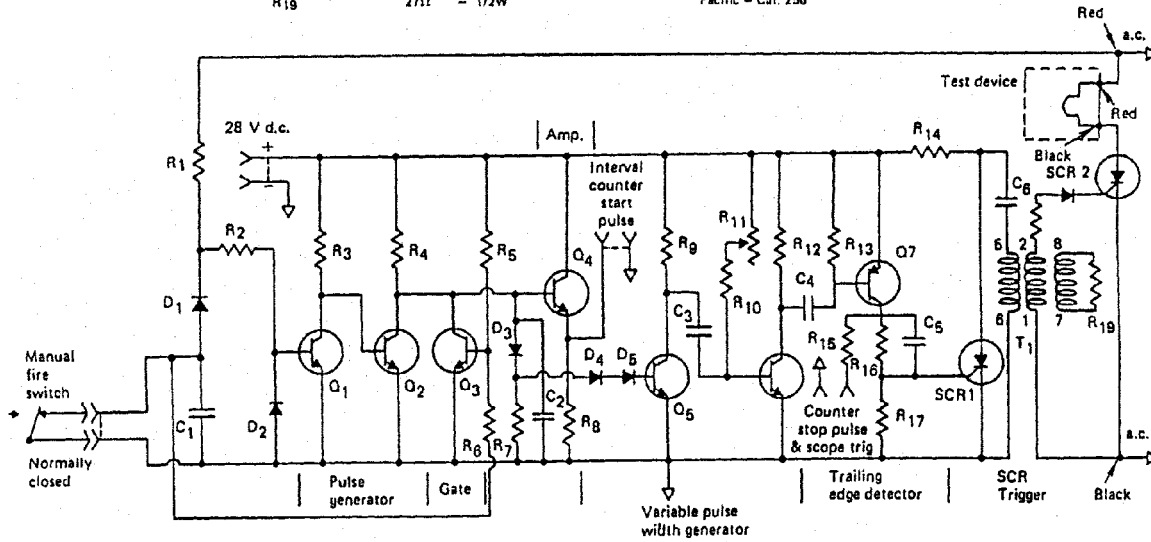
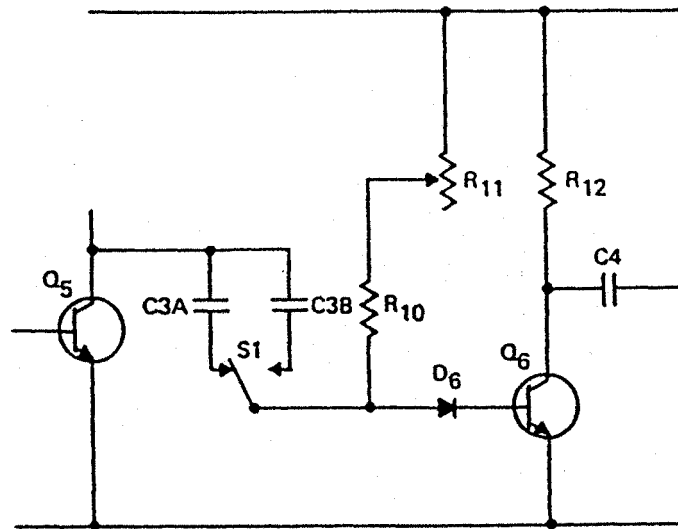

FIGURE 2 - 110, 208, and 440 V a.c. - 60 Hz Firing System.

**Figure 3. - Recommended Circuit Modifications.**



- C3A - 0.01  $\mu$ Fd at 16 V
- C3B - 0.04  $\mu$ Fd at 16 V
- R<sub>11</sub> - 220 $\Omega$  1/4W - ten-turn variable resistor
- D<sub>6</sub> - 1N4004
- S1 - Single pole - double throw switch

**FIGURE 3 - Recommended circuit modifications.**

### **TEST PROCEDURE**

Each detonator was tested in both confined and unconfined state. In the confined state, the detonator side surface was surrounded by a fiber-filled phenolic composite with the ends exposed. This composite has essentially the same density as the material which would surround the device in use. Each detonator had a PBX pellet adhered to the output face to enhance the verification of either detonation or deflagration. Two aluminum alloy blocks (Dural 6061) were placed at each end of the detonator (see Figure 4) for both firing states; the block facing the PBX pellet was used as a dent block for identification of detonation or deflagration. One of each detonator type was fired high order, unconfined and confined, and the dent blocks were retained for comparison.

**Figure 4. - Setup for Firing Detonators in the Confined State.**

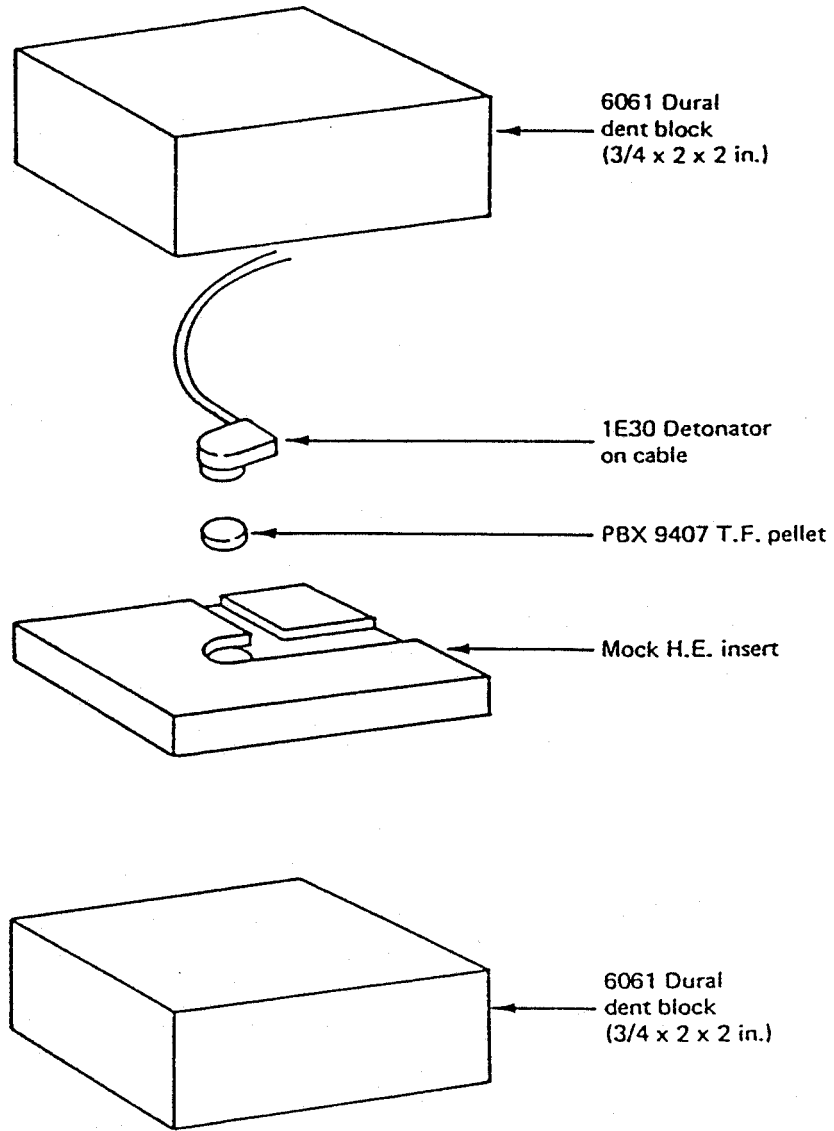

FIGURE 4 - Setup for firing  
detonators in the confined state.

## **FIRING RESULTS**

### **Preliminary Investigation**

Initially 50 assemblies were prepared for each of four detonator types with 25 to be tested unconfined and 25 confined.

Thirty assemblies of each type were assigned for testing at 110 V a.c., 10 for 208 V a.c., and 10 for 440 V a.c. Because of a delay in providing 208 and 440 V a.c. line service to the testing system, the 110 V a.c. tests were made first. Twenty assemblies of each type were fired beginning at the positive slope of the 60-Hz pulse, and the delay time was varied until the detonator firing characteristics were investigated over the entire positive half cycle. In all cases, equal numbers of unconfined and confined assemblies were tested. The remaining assemblies were retained for an accurate determination of threshold on the positive and negative slopes of the positive half cycle. Since only deflagration occurred at 110 V a.c., threshold was defined for deflagration.

Because no detonation occurred at 110 V a.c., only a few assemblies were subjected to the 208 and 440 V a.c. positive half-cycle peaks for evaluation of the effect of the increased peak voltage amplitude. Again, only deflagration occurred. The data acquired at this time were then reviewed by a joint LASL-Mound committee which made the following recommendations:

1. Twenty of each detonator type, 10 unconfined and 10 confined, should be tested at positive slope deflagration threshold - 110 V a.c.
2. Twenty of each detonator type, 10 unconfined and 10 confined, should be tested at negative slope deflagration threshold - 110 V a.c.
3. One hundred SE-1N detonator assemblies in the confined state should be subjected to 110 V a.c. using a conductor cable pair approximately 6 ft in length.
4. Twenty of each detonator type, 10 unconfined and 10 confined, should be subjected to 208 and 440 V a.c. positive half-cycle peaks.

Recommendations one and two were made to determine the deflagration threshold voltage precisely so that a deflagration probability could be determined. Recommendation three was included to confirm the probability by random testing. Recommendation four was made to ensure that the previous finding, deflagration not detonation, at the positive half-cycle peak of 208 and 440 V a.c. was the normal result, not the exception.

The test results were divided into four parts. The first test was a preliminary investigation of the positive and negative slopes of the positive half-cycle to determine the threshold areas of the 110 V a.c. waveform for each of the detonators. The results of the preliminary test are presented in Table 1. It was during this firing that it was noted that there was no discernible difference in the performance of confined and unconfined detonators. A detonator was also fired at the top of each of the three test waveforms. The intent of this procedure was to investigate the possibility of a detonation of the detonators at the worst-case condition for

each type of detonator. This investigation resulted in no detonations, but deflagrations for all detonators on the three waveforms.

**Table 1. - Threshold Conditions on the Positive and Negative Slopes on the 110 V a.c. Waveform for Each Type of Detonator ( $V_{rms} = 116$  Volts)**

Table 1 - THRESHOLD CONDITIONS ON THE POSITIVE AND NEGATIVE SLOPES OF THE 110 V a.c. WAVEFORM FOR EACH TYPE OF DETONATOR ( $V_{rms} = 116$  Volts)

Type of Det	$t_f$ (msec)	$V_f$ (V)	$t_b$ (usec)	$I_b$ (A)	Test Results x-Deflagrated o-Failed
SE-1N	0.2066	12.76	266.89	5.81	o
SE-1N	0.2457	15.17	250.04	6.38	x
SE-1N	0.4270	26.29	184.79	11.40	x
SE-1N	0.5480	33.64	162.64	14.50	x
SE-1N	1.113	66.81	104.24	24.61	x
SE-1N	1.149	68.84	101.59	23.82	x
SE-1N	1.926	108.89	75.57	36.21	x
SE-1N	2.263	123.55	68.03	38.28	x
SE-1N	3.766	162.13	52.14	44.32	x
SE-1N	4.019	163.75	55.99	45.63	x
SE-1N	4.593	161.89	59.58	44.97	x
SE-1N	5.364	147.6	64.57	41.59	x
SE-1N	6.234	116.7	77.69	33.74	x
SE-1N	6.725	93.5	92.11	33.72	o
SE-1N	7.408	56.1	111.78	20.45	o
LE30	0.207	12.78	277.10	8.7	x
LE30	0.208	12.8	275.39	8.9	x
LE30	0.298	18.4	236.58	10.11	x
LE30	0.696	42.5	143.93	19.31	x
LE30	3.836	162.7	58.39	50.24	x
LE30	4.034	163.8	55.86	48.74	x
LE30	4.044	163.8	57.06	49.39	x
LE30	5.029	115.4	63.45	47.17	x
LE30	6.724	93.5	93.97	30.47	x
LE30	6.752	92.1	95.49	29.22	x
LE30	6.863	86.3	101.69	27.40	x
LE30	6.978	80.2	107.04	25.94	o
LE30	7.137	71.5	121.78	21.52	o
LE30	7.474	52.2	170.42	12.28	o
LE31	0.203	12.5	189.5	6	o
LE31	0.220	13.6	175.9	8	o
LE31	1.167	69.8	68.03	22	x
LE31	1.172	70.1	67.30	22	x
LE31	2.193	120.7	46.60	30	x
LE31	4.049	163.8	38.13	35	x
LE31	4.151	164.0	38.14	36	x
LE31	4.531	162.4	37.81	36	x
LE31	5.883	130.8	47.55	31	x
LE31	6.541	102.6	56.26	27	x
LE31	6.708	94.3	59.13	24	x
LE31	7.096	73.8	73.09	20	o
LE31	7.275	63.7	93.08	16	x
LE31	7.368	58.4	86.04	17	o
LE31	7.450	53.6	95.11	15	o
LE31	7.792	33.2	153.34	6	o
LE33	0.2077	12.8	138.96	7	o
LE33	0.2501	15.43	127.33	8	o
LE33	0.5158	31.69	82.88	13	x
LE33	0.795	48.42	65.75	16	x
LE33	0.988	59.73	55.44	18	x
LE33	1.019	61.46	56.09	18	x
LE33	1.496	87.67	45.23	22	x
LE33	1.561	91.04	45.94	22.8	x
LE33	2.415	129.52	35.74	28	x
LE33	3.987	163.62	27.86	31	x
LE33	4.276	163.86	29.47	32	x
LE33	4.359	163.57	29.18	31	x
LE33	4.387	163.43	29.83	31	x
LE33	6.797	89.76	48.81	21	x
LE33	7.081	74.58	57.16	18	x
LE33	7.302	62.17	66.83	16	o
LE33	7.349	59.47	68.85	14	o
LE33	8.039	18.16			o
LE33	8.308	1.567			o

$t_f$  = Time after zero crossover when waveform voltage was placed on the detonator bridgewire or time of firing.  
 $V_f$  = Amplitude of waveform voltage at time of firing or firing voltage.  
 $t_b$  = Time after  $t_f$  when bridgewire burst took place.  
 $I_b$  = Amplitude of current through the bridgewire at the time of burst.

## 110-V Waveform

The second part of the test consisted of firing 40 detonators of each type on the nominal 110-V 60-Hz waveform. Twenty of each detonator type were fired on the positive slope of the waveform, and 20 were fired on the negative slope of the waveform. Each group of 20 detonators was used to determine the threshold of deflagration for that part of the waveform. Also, each group of 20 was divided into two parts, with one group of 10 fired in a confined configuration and the other group of 10 fired in an unconfined configuration.

Figures 5 and 6 illustrate the results from this test. The positive and negative slope thresholds of the deflagration are shown as the groupings of "x's" and "o's", indicating deflagration is expected between these two threshold regions, including the voltage maximum on the positive half-cycle.

The results of this testing (Table 2) were used to determine the statistical probability of one of these detonators deflagrating if it were "plugged into" a standard wall outlet.

A sample of 10 parts is insufficient for statistical comparisons. However, some of the data can be used to compare performance of confined and unconfined detonators. For instance, the data from the firing of the SE-1N may be used. The positive slope threshold firing time for this detonator was 0.267 msec when confined and 0.272 msec when unconfined. The negative slope threshold firing time was 6.322 msec when unconfined and 6.320 msec when confined. A similar comparison can be made of the negative slope threshold firing time of the 1E33 detonator: 7.048 msec unconfined and 7.063 msec confined. These confined and unconfined threshold firing times apply to these detonators deflagrating, not detonating.

**Figure 5. - Threshold Results for the SE-IN Detonator on the 110 V Waveform**

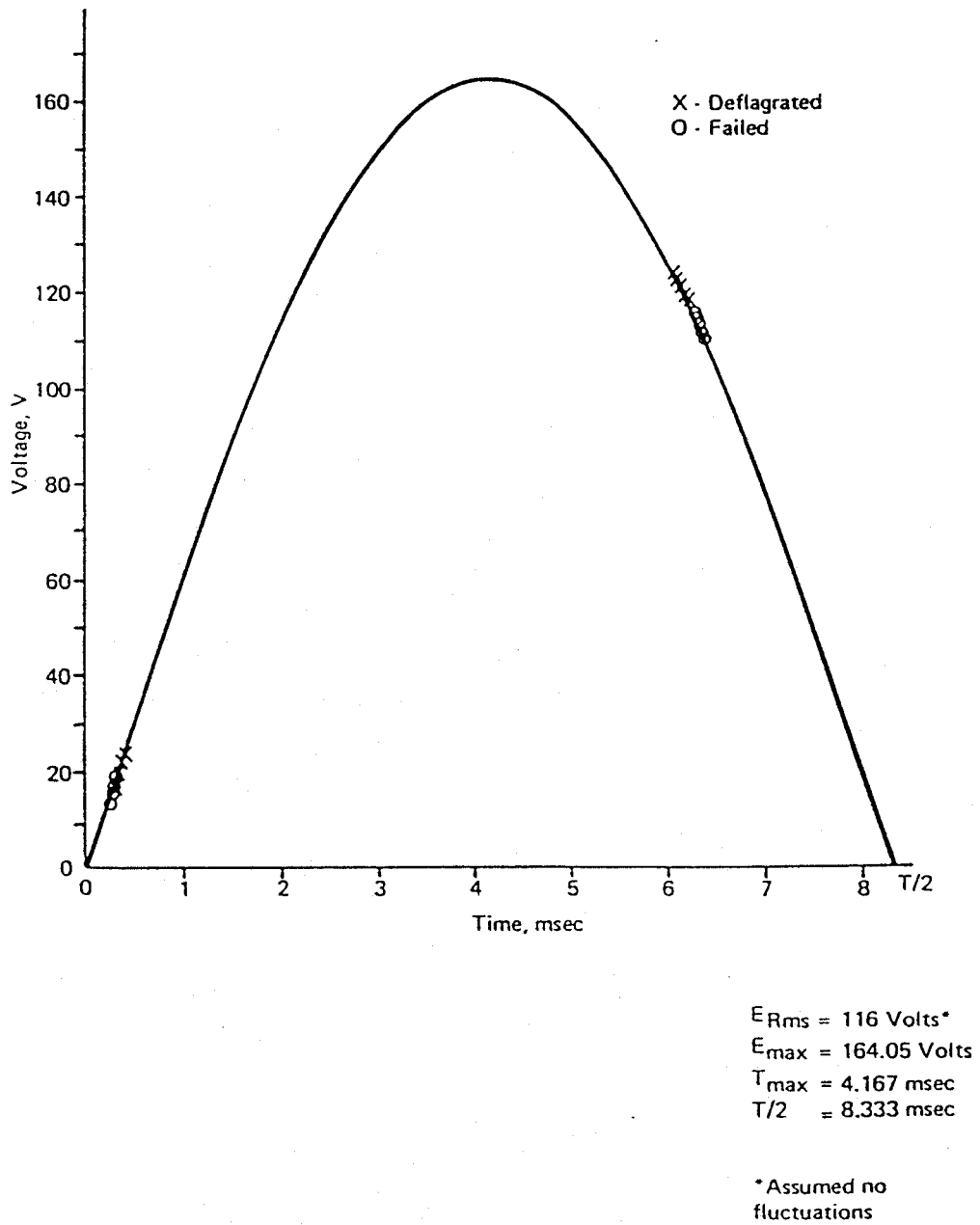
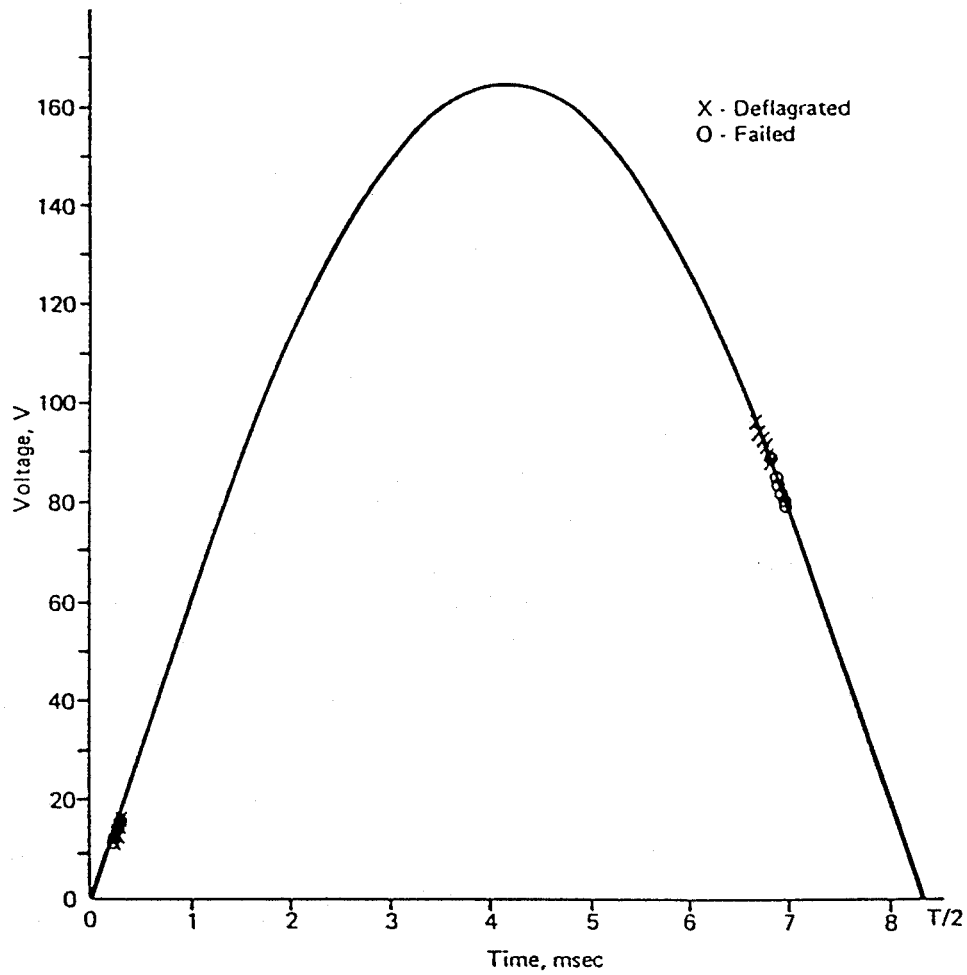

FIGURE 5 - Threshold results for the SE-IN detonator on the 110 V waveform.

Figure 6. -Threshold Results for the 1E30 Detonator on the 110 V



$E_{Rms} = 116 \text{ Volts}^*$   
 $E_{max} = 164.05 \text{ Volts}$   
 $T_{max} = 4.167 \text{ msec}$   
 $T/2 = 8.333 \text{ msec}$

\*Assumed no  
fluctuations

FIGURE 6 - Threshold results of the 1E30 detonator on the 110 V Waveform.

**Table 2. - Positive and Negative Slope Threshold for Each Test Detonator on the 110 V a.c. Waveform**

Table 2 - POSITIVE AND NEGATIVE SLOPE THRESHOLD FOR EACH TEST DETONATOR ON THE 110 V a.c. WAVEFORM						
Type of Det & Waveform Position	Status C-Confined U-Unconfined	t <sub>f</sub> (msec)	V <sub>f</sub> (V)	t <sub>b</sub> (sec)	I <sub>b</sub> (A)	Test Results x-Deflagrated o-Failed
<u>Positive Slope</u>						
1E30	U	0.2298	14.19	218.72	10.94	x
1E30	U	0.2309	14.26	223.76	11.30	x
1E30	U	0.2552	15.75	214.13	11.64	x
1E30	U	0.2687	16.58	215.63	11.95	x
1E30	U	0.2697	16.65	212.46	11.90	x
1E30	U	0.2706	16.70	208.48	12.08	x
1E30	U	-	-	229.33	10.10	x
1E30	U	-	-	238.85	10.46	x
1E30	U	-	-	248.65	10.81	o
1E30	C	0.1968	12.16	245.89	10.69	x
1E30	C	0.1968	12.16	254.64	10.59	o
1E30	C	0.1969	12.16	244.52	10.55	x
1E30	C	0.1969	12.16	245.42	10.57	o
1E30	C	0.1971	12.17	250.12	10.51	x
1E30	C	0.1972	12.18	244.11	10.43	x
1E30	C	0.1978	12.22	243.47	10.39	o
1E30	C	0.1987	12.27	236.37	10.85	x
1E30	C	0.1991	12.30	244.49	10.56	o
1E30	C	0.2020	12.47	250.42	10.46	x
<u>Negative Slope</u>						
1E30	U	6.774	90.95	97.21	30.11	x
1E30	U	6.300	89.61	96.63	29.62	x
1E30	U	6.801	89.56	96.41	30.37	x
1E30	U	6.809	89.14	98.05	29.45	x
1E30	U	6.892	84.79	103.10	27.77	o
1E30	U	6.904	84.16	102.73	27.61	o
1E30	U	6.981	80.04	104.47	26.05	o
1E30	U	6.987	79.71	106.80	26.37	o
1E30	U	6.992	79.44	106.43	26.04	o
1E30	U	7.058	75.85	106.76	24.98	o
1E30	C	6.695	94.98	94.28	32.15	x
1E30	C	6.741	92.64	95.54	31.71	x
1E30	C	6.759	91.72	97.98	31.08	x
1E30	C	6.774	90.95	99.29	30.83	x
1E30	C	6.868	86.06	100.95	29.34	o
1E30	C	6.895	84.63	101.61	28.30	o
1E30	C	6.897	84.53	103.21	28.91	o
1E30	C	6.908	83.94	103.08	28.35	o
1E30	C	6.923	83.15	101.07	27.99	o
1E30	C	7.063	75.57	108.35	25.32	o
<u>Positive Slope</u>						
SE-1N	U	0.2582	15.94	201.09	11.47	o
SE-1N	U	0.2584	15.95	210.60	11.53	x
SE-1N	U	0.2586	15.96	204.45	11.72	o
SE-1N	U	0.2593	16.00	213.54	11.50	o
SE-1N	U	0.2597	16.03	202.39	11.98	o
SE-1N	U	0.2632	16.25	203.73	11.72	o
SE-1N	U	0.2667	16.46	198.42	11.92	x
SE-1N	U	0.2675	16.51	200.87	11.48	o
SE-1N	U	0.3359	20.71	180.30	13.15	x
SE-1N	U	0.3611	22.26	174.30	13.30	x
SE-1N	C	0.2658	16.41	194.13	11.67	x
SE-1N	C	0.2659	16.41	202.50	11.87	o
SE-1N	C	0.2660	16.42	193.37	11.81	x
SE-1N	C	0.2663	16.44	194.90	11.55	x
SE-1N	C	0.2664	16.44	200.81	12.06	o
SE-1N	C	0.2669	16.47	199.17	11.79	o
SE-1N	C	0.2670	16.48	202.02	11.92	x
SE-1N	C	0.2670	16.48	199.09	12.01	x
SE-1N	C	0.2670	16.48	196.14	11.89	x
SE-1N	C	0.2671	16.49	203.28	11.67	o

### Table 2 Continued

Table 2 Continued						
Type of Det & Waveform Position	Status C-Confined U-Unconfined	$t_f$ (msec)	$V_f$ (V)	$t_b$ (usec)	$I_b$ (A)	Test Results x-Deflagrated o-Failed
<u>Negative Slope</u>						
SE-1N	U	6.177	119.11	78.58	37.17	x
SE-1N	U	6.193	118.43	75.80	37.96	x
SE-1N	U	6.247	116.10	77.40	37.16	x
SE-1N	U	6.274	114.91	75.27	36.00	x
SE-1N	U	6.317	112.10	79.91	36.20	o
SE-1N	U	6.339	112.01	79.94	36.06	o
SE-1N	U	6.351	111.47	80.65	36.34	o
SE-1N	U	6.360	111.06	78.70	36.18	o
SE-1N	U	6.363	110.92	80.06	35.67	o
SE-1N	U	6.384	109.96	81.07	35.65	o
SE-1N	C	6.184	118.82	76.07	38.02	x
SE-1N	C	6.257	115.66	78.86	37.03	x
SE-1N	C	6.314	113.13	77.94	37.13	x
SE-1N	C	6.318	112.96	79.87	36.48	o
SE-1N	C	6.327	112.55	79.39	36.24	o
SE-1N	C	6.328	112.51	78.62	36.62	x
SE-1N	C	6.332	112.33	79.22	36.54	o
SE-1N	C	6.340	111.97	78.03	36.12	o
SE-1N	C	6.340	111.97	79.33	36.20	o
SE-1N	C	6.362	110.97	79.69	36.16	o
LE31	U	0.3869	23.84	120.51	12.53	o
LE31	U	0.4008	24.68	119.42	12.83	o
LE31	U	0.4066	25.04	118.14	12.73	o
LE31	U	-	-	116.09	13.48	o
LE31	U	0.4342	26.72	112.31	13.42	x
LE31	U	0.4347	26.76	111.83	13.64	x
LE31	U	0.4421	27.21	113.06	13.86	x
LE31	U	0.4777	29.38	108.92	14.47	x
LE31	U	0.4790	29.45	106.03	14.65	x
LE31	U	0.5195	31.91	104.02	15.36	x
LE31	C	0.3962	24.40	151.96	9.24	o
LE31	C	0.4175	25.71	117.57	13.19	o
LE31	C	0.4434	27.29	114.28	13.75	o
LE31	C	0.4435	27.29	115.87	13.70	o
LE31	C	0.4445	27.25	112.61	13.73	o
LE31	C	0.4455	27.41	110.76	14.09	x
LE31	C	0.4465	27.48	111.99	13.98	o
LE31	C	0.4486	27.60	111.64	13.82	x
LE31	C	0.4845	29.79	105.85	14.64	x
LE31	C	0.5081	31.22	105.80	14.19	x
<u>Negative Slope</u>						
LE31	U	6.757	91.82	62.50	25.59	x
LE31	U	6.767	91.31	63.57	25.53	x
LE31	U	6.828	88.15	65.05	24.82	x
LE31	U	6.847	87.16	66.88	24.66	x
LE31	U	6.871	85.90	66.11	24.36	x
LE31	U	6.914	83.62	66.72	24.09	x
LE31	U	6.953	81.54	69.43	23.28	x
LE31	U	6.979	80.14	71.39	23.10	o
LE31	U	6.994	79.33	71.12	22.65	o
LE31	U	7.054	76.07	72.45	21.84	o
LE31	C	6.483	105.35	57.40	28.35	x
LE31	C	6.485	105.25	57.63	23.70	x
LE31	C	6.606	99.41	59.54	26.95	x
LE31	C	6.663	96.58	62.72	26.65	x
LE31	C	6.675	95.98	60.41	26.59	x
LE31	C	6.681	95.67	62.13	26.02	x
LE31	C	6.731	93.15	62.17	25.98	o
LE31	C	6.748	92.28	62.25	25.69	o
LE31	C	6.783	90.49	64.89	25.17	o
LE31	C	6.928	82.88	67.10	23.36	o

## Table 2 Continued

Table 2 Continued						
Type of Det & Waveform Position	Status C-Confined U-Unconfined	$t_f$ (msec)	$V_f$ (V)	$t_b$ (sec)	$I_b$ (A)	Test Results x-Deflagrated o-Failed
<u>Positive Slope</u>						
1E33	U	0.4098	25.24	95.13	11.90	o
1E33	U	0.4155	25.58	94.77	12.08	o
1E33	U	0.4220	25.98	90.44	12.20	o
1E33	U	0.4224	26.00	93.47	12.04	o
1E33	U	0.4655	28.63	87.53	12.73	o
1E33	U	0.4736	29.12	90.62	12.87	x
1E33	U	0.4890	30.06	86.70	13.23	x
1E33	U	-	-	84.74	12.97	x
1E33	U	0.0587	31.26	84.92	13.26	x
1E33	U	0.5145	31.61	85.63	13.28	x
1E33	C	0.4052	24.95	93.63	11.61	o
1E33	C	0.4311	26.54	89.33	11.87	o
1E33	C	0.4460	27.44	89.93	12.32	o
1E33	C	0.4612	28.37	88.68	12.66	x
1E33	C	0.4638	28.53	89.16	12.62	o
1E33	C	0.4642	28.55	88.39	12.90	x
1E33	C	0.4682	28.80	86.61	12.61	o
1E33	C	0.4771	29.34	87.50	12.76	x
1E33	C	0.5055	31.06	85.60	13.33	x
1E33	C	0.5070	31.16	82.55	13.55	x
<u>Negative Slope</u>						
1E33	U	6.892	84.79	53.61	21.15	x
1E33	U	6.916	83.52	53.43	21.11	x
1E33	U	6.991	79.50	57.28	20.22	x
1E33	U	7.008	78.57	57.22	20.01	x
1E33	U	7.024	77.70	57.75	19.91	x
1E33	U	7.044	76.61	57.22	19.45	x
1E33	U	7.067	75.35	58.58	19.23	o
1E33	U	7.111	72.93	61.60	18.74	o
1E33	U	7.226	66.59	64.50	17.90	o
1E33	U	7.569	46.61	81.89	12.53	o
1E33	C	6.869	86.00	51.73	21.29	x
1E33	C	6.923	83.15	57.08	20.60	x
1E33	C	6.934	82.56	53.45	20.30	x
1E33	C	7.029	77.52	56.04	19.54	x
1E33	C	7.046	76.50	58.07	19.27	x
1E33	C	7.082	74.53	59.99	19.07	o
1E33	C	7.093	73.92	59.70	18.83	o
1E33	C	7.196	63.18	63.75	17.60	o
1E33	C	7.221	66.78	63.96	16.50	o
1E33	C	7.256	64.79	65.12	16.89	o

$t_f$ ,  $V_f$ ,  $t_b$  and  $I_b$  same as at bottom of Table 1.

## **208 and 440-V Waveforms**

The third part of the testing consisted of firing 20 of each type of detonator just approaching the top of the 208 V a.c. and the 440 V a.c. waveforms. Each group of 20 detonators was divided in half, half fired in a confined configuration and half fired unconfined. During the firing there were no detonations of any of the detonators on either of these waveforms. The results are presented in Table 3.

## **Random Firing**

The fourth and last part of the test was a random firing of 100 SE-1N detonators on the 110 V a.c. waveform to determine the percent of the detonators that deflagrated. This percentage, 76%, was comparable to the probability calculated from the second part of the test, 73% with a standard deviation of 0.22%. The results of this random firing test are presented in Table 4.

**Table 3 - Testing of the Four Types of Detonators on the 208 V a.c. and the 440 V a.c. Waveform**

Table 3 - TESTING OF THE 4 TYPES OF DETONATORS ON THE 208 V a.c. AND THE 440 V a.c. WAVEFORM<sup>a</sup>

Type of Det & Voltage Waveform	t <sub>f</sub> Unconfined (msec)	t <sub>f</sub> Confined (msec)
<u>208 V a.c.</u>		
SE-1N	3.629	4.015
SE-1N	3.645	3.745
SE-1N	3.564	3.727
SE-1N	3.497	3.689
SE-1N	3.522	3.678
SE-1N	3.547	3.866
SE-1N	3.559	3.662
SE-1N	3.665	3.683
SE-1N	3.639	3.834
SE-1N	3.647	3.657
1E30	3.669	3.670
1E30	3.655	3.657
1E30	3.659	3.670
1E30	3.658	3.684
1E30	3.635	3.655
1E30	3.656	3.659
1E30	3.650	3.659
1E30	3.636	3.649
1E30	3.649	3.711
1E30	3.640	3.662
1E31	3.739	3.783
1E31	3.699	3.741
1E31	3.712	3.700
1E31	3.702	3.695
1E31	3.692	3.696
1E31	3.678	3.679
1E31	3.666	3.754
1E31	3.674	3.755
1E31	3.661	3.751
1E31	3.654	3.726
1E33	3.792	3.689
1E33	3.764	3.699
1E33	3.754	3.687
1E33	3.744	3.686
1E33	3.732	3.679
1E33	3.708	3.683
1E33	3.723	3.682
1E33	3.703	3.686
1E33	3.793	3.687
1E33	3.688	3.683
<u>440 V. a.c.</u>		
SE-1N	3.787	3.960
SE-1N	3.780	4.054
SE-1N	-	4.071
SE-1N	3.770	3.776
SE-1N	-	3.748
SE-1N	4.500	3.748
SE-1N	3.936	3.742
SE-1N	3.879	3.727
SE-1N	3.809	3.720
SE-1N	3.887	3.759
1E30	4.324	3.693
1E30	-	3.690
1E30	3.858	3.681
1E30	3.835	3.690
1E30	3.791	3.676
1E30	-	3.669

<sup>a</sup>All the detonators presented in this table deflagrated. No detonations occurred.

### Table 3 - Continued

Table 3 Continued

Type of Det & Voltage Waveform	$t_f$ Unconfined (msec)	$t_f$ Confined (msec)
1E30	3.754	3.661
1E30	3.749	3.658
1E30	3.740	3.653
1E30	3.718	3.640
1E31	3.641	-
1E31	3.645	3.960
1E31	3.645	3.954
1E31	3.635	3.745
1E31	3.647	-
1E31	3.643	3.893
1E31	3.647	3.851
1E31	3.644	3.851
1E31	3.643	3.839
1E31	4.219	3.832
1E33	3.830	3.792
1E33	3.812	3.783
1E33	3.804	3.748
1E33	3.803	3.751
1E33	3.799	3.740
1E33	3.803	3.731
1E33	3.791	3.787
1E33	3.781	3.746
1E33	3.776	-
1E33	3.781	-

$t_f$  = time after zero crossover when waveform voltage was placed on the detonator bridgewire or time of firing.

**Table 4 - Random Testing of 100 SE-IN Detonators**

Table 4 - RANDOM TESTING OF 100 SE-IN DETONATORS

Det. No.	Results x-Deflagrated o-Failed	Det. No.	Results x-Deflagrated o-Failed
1	x	48	o
2	x	49	o
3	o	50	x
4	x	51	x
5	x	52	x
6	x	53	o
7	o	54	x
8	o	55	x
9	o	56	x
10	x	57	x
11	o	58	x
12	x	59	x
13	x	60	x
14	x	61	x
15	x	62	x
16	x	63	x
17	x	64	x
18	x	65	x
19	x	66	o
20	o	67	x
21	x	68	o
22	x	69	x
23	x	70	o
24	x	71	x
25	o	72	x
26	x	73	x
27	x	74	x
28	x	75	o
29	o	76	o
30	x	77	x
31	o	78	x
32	x	79	x
33	x	80	o
34	x	81	x
35	x	82	x
36	o	83	x
37	o	84	x
38	x	85	x
39	x	86	x
40	x	87	o
41	x	88	x
42	x	89	o
43	x	90	x
44	x	91	x
45	x	92	x
46	x	93	o
47	x	94	x
		95	x
		96	x
		97	x
		98	o
		99	x
		100	x

## Statistical Inference

A half-cycle of the voltage sine wave used in this testing is shown in Figure 7. The remaining half-cycle is identical except the sign changes on the voltage values. The

locations of  $u_1$  and  $u_2$  approximate the threshold values on the positive and negative slopes of the sine wave. All shots fired between time  $u_1$  and  $u_2$  are expected to deflagrate and those outside these limits are not.

Although the firing voltage is an important parameter leading to deflagration, the voltage gradient with respect to time is equally important as manifested by the much higher voltage threshold at the negative slope where the gradient is negative. Given two equally important parameters and many others that can affect the deflagration, we have an experimental system with a fair number of independent factors, each of which has an influence on the firing time thresholds. Thus, we can safely assume that if  $t_1$  is the positive slope threshold, it is normally distributed around a certain mean  $u_1$ . The same is true regarding the negative slope threshold  $t_2$ .

The test data shown in Table 2 were analyzed, using this distribution assumption, with the sensitivity test analysis procedure [1]. The resultant sample means and the standard deviations are given in Table 5. Given a proper selection of firing times, a fairly accurate estimate can usually be obtained. As seen in the table, the standard deviations are small in most cases. However, the larger deviations for the 1E31 indicate wider spreads of the threshold values. For the 1E33, the selected firing times on the negative slope waveform fail to cross the estimated threshold value, thus making it impossible to estimate the standard deviation. The test data in this case are insufficient for concluding whether the population standard deviation is too small or the sample points are too few.

Referring to Figure 7, we have the time thresholds  $t_1$  and  $t_2$  normally distributed around the estimated means  $u_1$  and  $u_2$  such that the device is expected to deflagrate when  $t_1 < t < t_2$  and not when  $t > t_1$  or  $t < t_2$ . The probability of deflagration when  $t$  is uniformly distributed over the entire half cycle of the voltage sine wave,  $T/2$ , is consequently distributed normally with the mean

$$\mu = \frac{\mu_1 - \mu_2}{T/2} \text{ and the}$$

standard deviation

$$\sigma = \sqrt{\frac{s_1^2 + s_2^2}{(T/2)^2}}$$

Substituting the values in Table 5, we arrive at the total probability of deflagrations and the associated standard deviation as shown in Table 6.

In Table 6 the calculated probability for the SE-1N deflagrating is 72.7% based on the total sample size of 40 units. In the random firing test 76 of the 100 SE-1N units, 76%, deflagrated. These results compare well considering the small sampling involved.

**Figure 7 - The Time Results and the Assumption that the Threshold Data was Normal were Used to Calculate the Probabilities.**

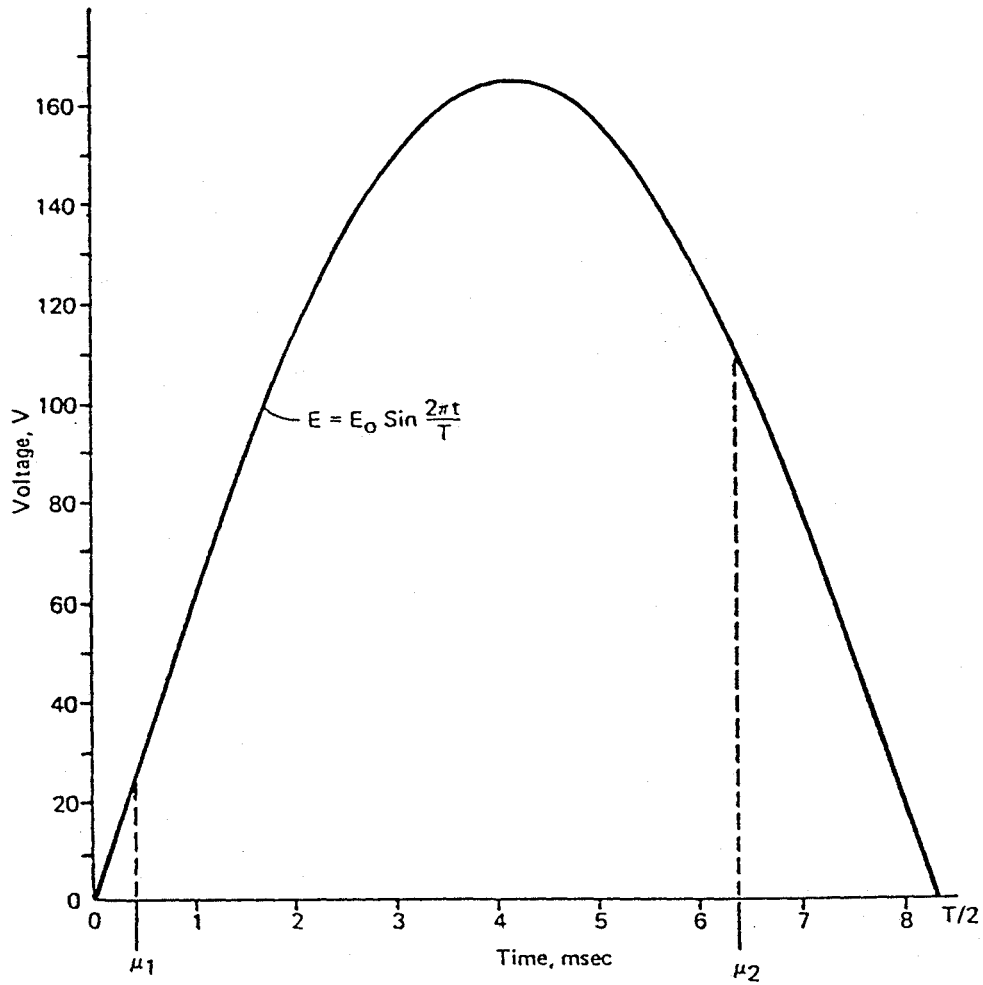

$E_{Rms} = 116 \text{ Volts}^*$   
 $E_{max} = 164.05 \text{ Volts}$   
 $T_{max} = 4.167 \text{ msec}$   
 $T/2 = 8.333 \text{ msec}$

\*Assumed no fluctuations

FIGURE 7 - The time results and the assumption that the threshold data was normal were used to calculate the probabilities.

**Table 5 - The Estimated Time Threshold**

Table 5 - THE ESTIMATED TIME THRESHOLD

Type of Det.	Positive Slope Time Threshold $\mu_1$ (msec)	Std. Deviation $\sigma_1$ (msec)	Negative Slope Time Threshold $\mu_2$ (msec)	Std. Deviation $\sigma_2$ (msec)
SE-1N	0.266	0.0081	6.320	0.0097
1E30	0.197	0.0058	6.865	0.0280
1E31	0.441	0.0195	6.886	0.1933
1E33	0.465	0.0099	7.058	-

**Table 6 - The Probability of Deflagration at Random Firing Time**

Table 6 - THE PROBABILITY OF DEFLAGRATION AT RANDOM FIRING TIME

Type of Det.	Probability of a Deflagration	Standard Deviation
SE-1N	0.727	0.0022
1E30	0.800	0.0049
1E31	0.773	0.0330
1E33	0.791	0.0017

## Conclusions

During the entire testing of the four types of detonators on the three types of 60-Hz waveforms, none of the test units detonated. Only deflagrations or failures occurred. Assuming unbiased sampling, we estimate the probability of detonation to be one in 10-12.

There are enough data to indicate that there is no discernable difference in deflagration performance between the confined and unconfined test units on the 60-Hz waveforms.

## Reference

1. H. J. Langlie, "A Reliability Test Method for One-Shot Items," Publication No. U-1792, Aeronutronic, Newport Beach, CA. (1962).

## EFFECTS OF AC POWER ON EBW DETONATORS

A personal injury accident investigation revealed the cause of the injury to be deflagration of a commercial EBW detonator, the firing leads having come in contact with 110 VAC power.

The EBW detonator was partially confined in a device, assembled using an adhesive designed to fail at 2,700 psig. The adhesive failed as designed. Effectively, a shape charge effect directed the energy of the deflagration, causing serious digital injury to the person.

Research revealed a study conducted by Gerald E. Round, Tien S. Chou, and J. Richard Taylor, of the Mound Facility in Miamisburg, Ohio. This study was conducted for the Department of Energy. This study is attached as part of this paper.

John Montoya, Sandia National Laboratories, Albuquerque, New Mexico, developed T-Line Codes, which were calibrated to the Mound Data. The composition of the EBWs used in the Mound study were essentially identical to the commercial EBWs involved in the incident. Geometric configuration of the EBW bodies was considered to be negligible for the purposes of this investigation.

There is a high level of confidence that EBWs will deflagrate approximately 76% of the time when exposed to commercial line voltage at the 60-Hz frequency. Personnel handling EBWs need to be reminded of the potential for deflagration, which could result in potentially serious physical injury.