

# **The Role of Structural Damping in Dynamic Response**

by

Sam A. Kiger

West Virginia University  
Morgantown, WV

## **OUTLINE**

- The Computational Models
- Structural Damping
- Example
- Conclusions

# Report Documentation Page

Form Approved  
OMB No. 0704-0188

Public reporting burden for the collection of information is estimated to average 1 hour per response, including the time for reviewing instructions, searching existing data sources, gathering and maintaining the data needed, and completing and reviewing the collection of information. Send comments regarding this burden estimate or any other aspect of this collection of information, including suggestions for reducing this burden, to Washington Headquarters Services, Directorate for Information Operations and Reports, 1215 Jefferson Davis Highway, Suite 1204, Arlington VA 22202-4302. Respondents should be aware that notwithstanding any other provision of law, no person shall be subject to a penalty for failing to comply with a collection of information if it does not display a currently valid OMB control number.

1. REPORT DATE <b>AUG 1994</b>		2. REPORT TYPE		3. DATES COVERED <b>00-00-1994 to 00-00-1994</b>	
4. TITLE AND SUBTITLE <b>The Role of Structural Damping in Dynamic Response</b>				5a. CONTRACT NUMBER	
				5b. GRANT NUMBER	
				5c. PROGRAM ELEMENT NUMBER	
6. AUTHOR(S)				5d. PROJECT NUMBER	
				5e. TASK NUMBER	
				5f. WORK UNIT NUMBER	
7. PERFORMING ORGANIZATION NAME(S) AND ADDRESS(ES) <b>West Virginia University, Civil &amp; Environmental Engineering, PO Box 6103, Morgantown, WV, 26506-6103</b>				8. PERFORMING ORGANIZATION REPORT NUMBER	
9. SPONSORING/MONITORING AGENCY NAME(S) AND ADDRESS(ES)				10. SPONSOR/MONITOR'S ACRONYM(S)	
				11. SPONSOR/MONITOR'S REPORT NUMBER(S)	
12. DISTRIBUTION/AVAILABILITY STATEMENT <b>Approved for public release; distribution unlimited</b>					
13. SUPPLEMENTARY NOTES <b>See also ADM000767. Proceedings of the Twenty-Sixth DoD Explosives Safety Seminar Held in Miami, FL on 16-18 August 1994.</b>					
14. ABSTRACT					
15. SUBJECT TERMS					
16. SECURITY CLASSIFICATION OF:			17. LIMITATION OF ABSTRACT <b>Same as Report (SAR)</b>	18. NUMBER OF PAGES <b>7</b>	19a. NAME OF RESPONSIBLE PERSON
a. REPORT <b>unclassified</b>	b. ABSTRACT <b>unclassified</b>	c. THIS PAGE <b>unclassified</b>			

## SDOF MODEL

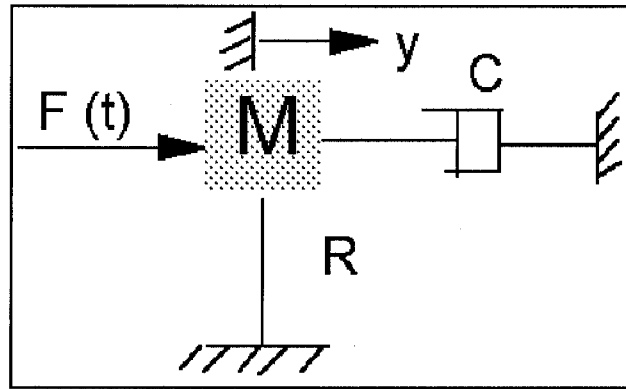

The SDOF “Equivalent” parameters are based on an assumed response (or failure) mode.

$$M\ddot{y} + C\dot{y} + R = F(t)$$

## SMI MODEL (SDOF)

Ignore Damping and rewrite the SDOF equation as:

### EQUATION

$$\ddot{y} + \frac{r}{\rho d} = \frac{P(t)}{\rho d}$$

Where

$r$  is resistance in force per unit area

$p$  is loading in force per unit area

$\rho$  is mass density

and  $d$  is structural thickness

$$\begin{aligned} P(t) &= \sigma_i + \sigma_r \\ &= \sigma_i + \rho_s C_s \Delta v \\ &= \sigma_i + \rho_s C_s (v - \dot{y}) \\ &= 2\sigma_i - \rho_s C_s \dot{y} \end{aligned}$$

Then

$$\ddot{y} + \frac{\rho_s C_s}{\rho d} \dot{y} + \frac{r}{\rho d} = \frac{2\sigma_i}{\rho d}$$

This equation assumes elastic behavior. In fact, the media wave speed,  $C_s$ , is difficult to define during plastic response.

## DAMPING

Almost all descriptions of damping are derived from a linear SDOF system with a viscous damper in parallel with the spring, and all damping measurements relate to energy loss per cycle of motion.

Several investigators have recommended use of large damping ratios during plastic response calculations, for example:

Hinman and Weidlinger (87)  
Drake, et.al. (87 and 89)  
Krauthainmer, et.al. (84 and 86)  
and Serena (92)

## EXAMPLE

Assume a reinforced concrete slab

Maximum Resistance      100 psi  
Peak Load:                    300 psi  
Load Duration:                4 ms

<b>Damping (Percent of Critical)</b>	<b>Deflection (in)</b>
0	7.4
5	5.9
10	4.9
15	4.3
20	3.7
25	3.3
40	2.5

Damping 25 percent of critical and peak load: 300 psi  
and Duration: 4 ms

<b>Max Resistance (psi)</b>	<b>Deflection (in)</b>
100	3.3
50	4.7
10	7.1
7	7.4

Thus, deflection of the 7 psi slab with 25 percent damping is the same as the 100 psi slab with no damping.

Items often neglected in SDOF model:

Loading:

- Non Uniform Loading
- Localized Loading
- Time Phasing of Loading
- Fragment Loading
- Unloading of Reflected Pressure From Openings and Edges

Resistance:

- Two-Way Effects
- Compressive Membrane Action
- Tensile Membrane Resistance
- Rate Effects

Soil - Structure Interaction

- Soil Arching
- Soil Strength

## **CONCLUSIONS**

- Even small amounts of damping can significantly effect calculations in the plastic response region.
- Damping for plastic response can not be defined.
- Experimental or analytical verification for Damping during plastic response is not available.
- Damping should not be used when plastic response is the predominant mode.

## REFERENCES

- Drake, J.L., et.al., (1989). "Protective Construction Design Manual", ESL-TR87-57, Air Force Engineering and Services Center, Tyndall AFB, FL, November 1987.
- Drake, J.L., Frank, R.A. and Rechefort, M.A. (1987). "A Simplified Method for the Prediction of The Ground Shock Loads on Structures", Proceedings of Symposium Interaktion Konventioneller Munition Mit Schutzbauten, Bundesrepublik Deutschland, Mannheim, 9-13 March 1987.
- Hinman, H. and Weidlinger, P. (1987). "SDOF Solutions of Structure-Medium Interaction", Proceedings of Symposium Interaktion Konventioneller Munition Mit Schutzbauten, Bundesrepublik Deutschland, Mannheim, 9-13 March 1987.
- Krauthammer, T. (1981). "Revaluation of Test Results on Shallow-Buried Structures." *Proc. Tenth Int. Conference on Soil Mech. and Foundation Engrg.*, Stockholm, Sweden.
- Krauthammer, T. (1984). "Shallow Buried RC Box-Type Structures." *J. Struct. Engrg.*, ASCE, 110(ST3), 637-651.
- Krauthammer, T., Bazeos, N. and Holmquist, T.J. (1986). "Modified SDOF Analysis of RC Box-Type Structures", *J. Struct. Engrg.*, Vol. 112, No. 4, pp. 726-744, April 1986.
- Johansen, K.W. (1943). Brudlinieteorier. Copenhagen, Denmark; English Translation, Yield-Line Theory, Cement and Concrete Association, London, U.K. 1962.
- Kiger, S.A. (1988). "Ultimate Capacity of Earth-Covered Slabs", *J. Struct. Engineering*, ASCE, Vol. 114, No. 10, pp. 2343-2356.
- Kiger, S.A., Hyde, D.W. and Guice, L.K. (1987). "Flexural Response of Reinforced-Concrete Structures to Conventional Weapons", Proceedings of Symposium Interaktion Konventioneller Munition Mit Schutzbauten, Bundesrepublik Deutschland, Mannheim, 9-13 March 1987.
- Park, R. and Gamble, W.L. (1980). Reinforced Concrete Slabs. John Wiley and Sons, New York, NY, pp. 562-609.
- Serena, J.M. (1992). "Development of a New Rectangular Box-Shaped Standard Ammunition Storage Magazine," Minutes of the Twenty-Fifth Explosive Safety Seminar, Vol. 1, pp. 313-330, Dept. of Defense Explosive Safety Board, Alexandria, VA, 18-20 August 1992.