



AFRL-RZ-WP-TP-2009-2179

**TRANSITION IN GAS TURBINE ENGINE CONTROL
SYSTEM ARCHITECTURE: MODULAR, DISTRIBUTED,
EMBEDDED (POSTPRINT)**

**Bruce Wood, Derek Weber, Bill Rhoden, Bill Mailander, Gary Hunter, Dennis Culley,
Casey Carter, Dewey Benson, and Al Behbahani**

**Fan and Compressor Branch
Turbine Engine Division**

AUGUST 2009

Approved for public release; distribution unlimited.

See additional restrictions described on inside pages

STINFO COPY

**AIR FORCE RESEARCH LABORATORY
PROPULSION DIRECTORATE
WRIGHT-PATTERSON AIR FORCE BASE, OH 45433-7251
AIR FORCE MATERIEL COMMAND
UNITED STATES AIR FORCE**

| REPORT DOCUMENTATION PAGE | | | | <i>Form Approved</i> OMB No. 0704-0188 | |
|--|------------------------------------|--|---|---|---|
| <p>The public reporting burden for this collection of information is estimated to average 1 hour per response, including the time for reviewing instructions, searching existing data sources, gathering and maintaining the data needed, and completing and reviewing the collection of information. Send comments regarding this burden estimate or any other aspect of this collection of information, including suggestions for reducing this burden, to Department of Defense, Washington Headquarters Services, Directorate for Information Operations and Reports (0704-0188), 1215 Jefferson Davis Highway, Suite 1204, Arlington, VA 22202-4302. Respondents should be aware that notwithstanding any other provision of law, no person shall be subject to any penalty for failing to comply with a collection of information if it does not display a currently valid OMB control number. PLEASE DO NOT RETURN YOUR FORM TO THE ABOVE ADDRESS.</p> | | | | | |
| 1. REPORT DATE (DD-MM-YY) August 2009 | | 2. REPORT TYPE Conference Proceedings Postprint | | 3. DATES COVERED (From - To) 04 August 2009 – 04 August 2009 | |
| 4. TITLE AND SUBTITLE TRANSITION IN GAS TURBINE ENGINE CONTROL SYSTEM ARCHITECTURE: MODULAR, DISTRIBUTED, EMBEDDED (POSTPRINT) | | | | 5a. CONTRACT NUMBER In-house | |
| | | | | 5b. GRANT NUMBER | |
| | | | | 5c. PROGRAM ELEMENT NUMBER 62203F | |
| 6. AUTHOR(S) Bruce Wood (Pratt & Whitney) Derek Weber (Inprox Technology) Bill Rhoden (Hamilton-Sundstrand) Bill Mailander (GE Aviation) Gary Hunter and Dennis Culley (NASA Glenn Research Center) Casey Carter (BAE Systems) Dewey Benson (Honeywell) Alireza R. Behbahani (AFRL/RZTF) | | | | 5d. PROJECT NUMBER N/A | |
| | | | | 5e. TASK NUMBER N/A | |
| | | | | 5f. WORK UNIT NUMBER N/A | |
| 7. PERFORMING ORGANIZATION NAME(S) AND ADDRESS(ES) | | | | 8. PERFORMING ORGANIZATION REPORT NUMBER AFRL-RZ-WP-TP-2009-2179 | |
| Pratt & Whitney | | BAE Systems | | | |
| Inprox Technology | | Honeywell | | | |
| Hamilton-Sundstrand | | Fan and Compressor Branch (AFRL/RZTF) | | | |
| GE Aviation | | Turbine Engine Division | | | |
| NASA Glenn Research Center | | Air Force Research Laboratory, Propulsion Directorate Wright-Patterson Air Force Base, OH 45433-7251 Air Force Materiel Command, United States Air Force | | | |
| 9. SPONSORING/MONITORING AGENCY NAME(S) AND ADDRESS(ES) | | | | 10. SPONSORING/MONITORING AGENCY ACRONYM(S) AFRL/RZTF | |
| Air Force Research Laboratory Propulsion Directorate Wright-Patterson Air Force Base, OH 45433-7251 Air Force Materiel Command United States Air Force | | | | 11. SPONSORING/MONITORING AGENCY REPORT NUMBER(S) AFRL-RZ-WP-TP-2009-2179 | |
| 12. DISTRIBUTION/AVAILABILITY STATEMENT Approved for public release; distribution unlimited. | | | | | |
| 13. SUPPLEMENTARY NOTES Conference proceedings of the 45th AIAA/ASME/SAE/ASEE Joint Propulsion Conference, 2-5 Aug 2009, Denver, CO. PAO Case Number: 88ABW-2009-3531, 01 Jul 2009. Paper contains color and consists of briefing charts. This presentation was individually prepared by different organizations. The U.S. Government is joint author of this work and has the right to use, modify, reproduce, release, perform, display, or disclose the work. | | | | | |
| 14. ABSTRACT Presentations from the Distributed Engine Control Working Group included: Vision and need for future turbine engine control; Implementation and technology challenges; High temperature electronics; Innovation and entry barriers. | | | | | |
| 15. SUBJECT TERMS Gas turbines, Distributed Engine Control Working Group (DEC), High temperature electronics | | | | | |
| 16. SECURITY CLASSIFICATION OF: | | | 17. LIMITATION OF ABSTRACT: SAR | 18. NUMBER OF PAGES 84 | 19a. NAME OF RESPONSIBLE PERSON (Monitor) Alireza R. Behbahani 19b. TELEPHONE NUMBER (Include Area Code) N/A |
| a. REPORT Unclassified | b. ABSTRACT Unclassified | c. THIS PAGE Unclassified | | | |

**45th AIAA/ASME/SAE/ASEE Joint Propulsion
Conference & Exhibit**

4 August 2009
Colorado Convention Center
Denver, Colorado

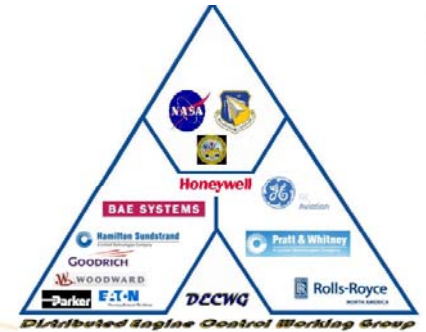

Panel Session on

Transition in Gas Turbine Engine Control System Architecture: Modular, Distributed, Embedded

By the ***Distributed Engine Control Working Group***

Session Chair: Dennis Culley

DECWG

Distributed Engine Control Working Group

Approved for Public Release

1

Panel Members

Bruce Wood, *Pratt & Whitney*

Derek Weber, *Inprox Technology*

Bill Rhoden, *Hamilton-Sundstrand*

Bill Mailander, *GE Aviation*

Gary Hunter, *NASA Glenn Research Center*

Dennis Culley, *NASA Glenn Research Center*

Casey Carter, *BAE Systems*

Dewey Benson, *Honeywell*

Al Behbahani, *Air Force Research Laboratory*

Outline

- Motivation / Objective
- Collaborative Hardware Demonstration
- Vision & Need for Future Turbine Engine Control
- Implementation & Technical Challenges
- High Temperature Electronics
- Innovation
- Summary & Future Plans

Motivation / Objective

- Are engine control systems keeping pace with turbine engine system needs?
- What technologies are required for existing and future engine control systems?
- *How Do & Why Should* engine control systems take advantage of emerging electronics and control technologies?
- What is the go-forward plan for the turbine engine controls community?

Traditional Centralized Architecture

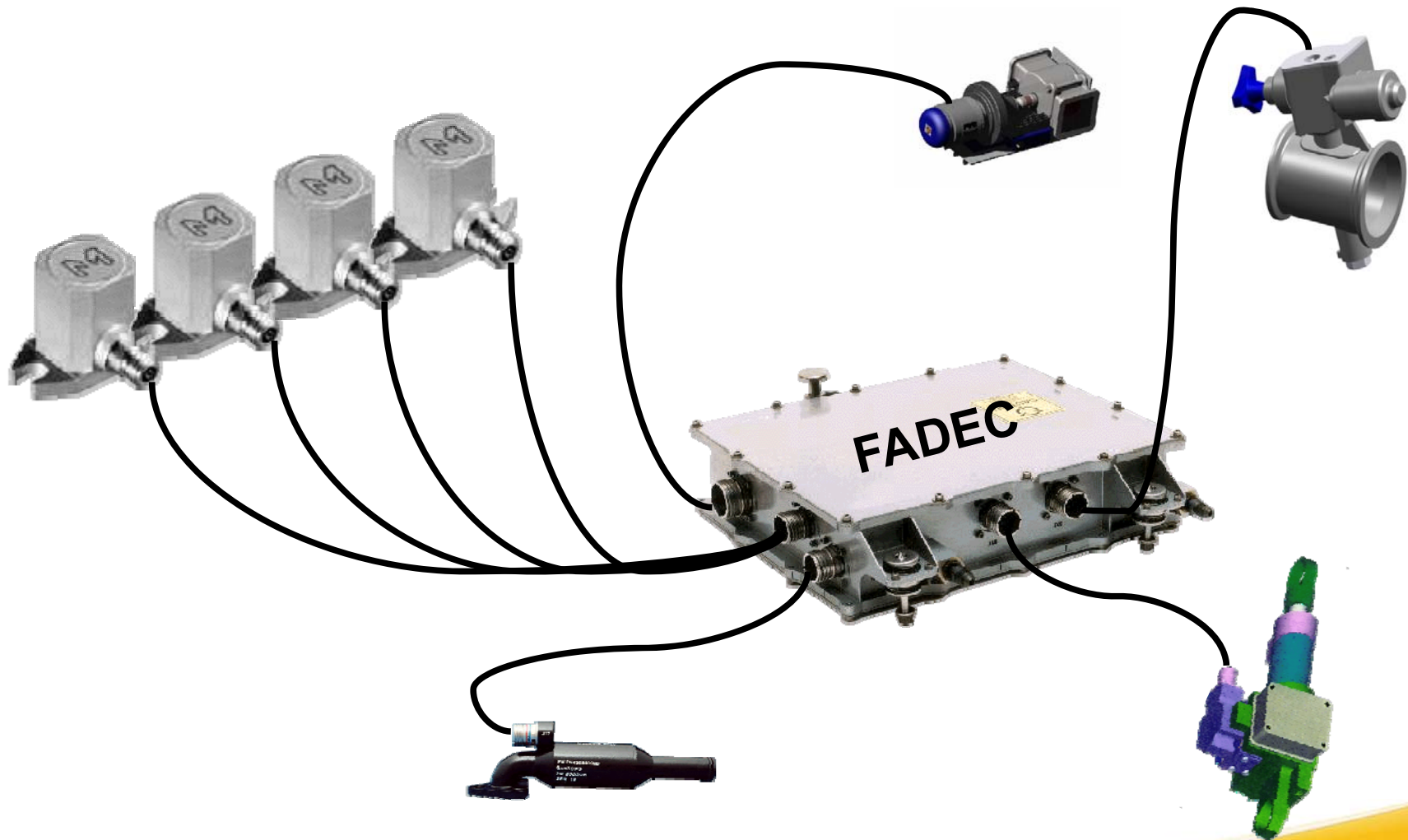

Example of Distributed Architecture

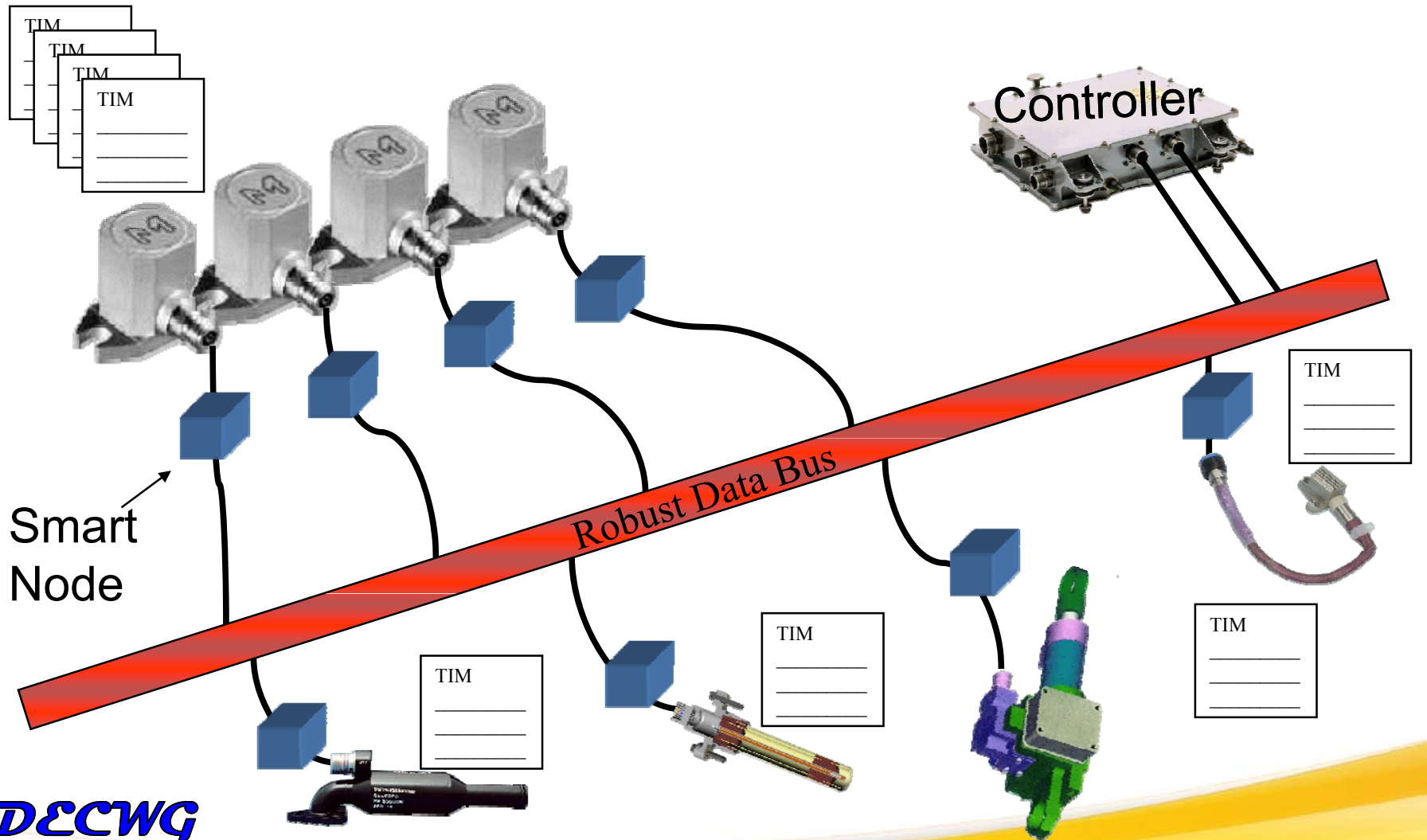

DECWG

Distributed Engine Control Working Group

Approved for Public Release

Thoughts to Keep in Mind

- Turbine engine controls have made transitions to new technologies in the past – what were the driving factors behind these changes?
- What is the relationship between the electronics industry and mission critical electronics applications like turbine engine control systems?

Hardware Demonstration

Industry can, and has shown a willingness to collaborate.

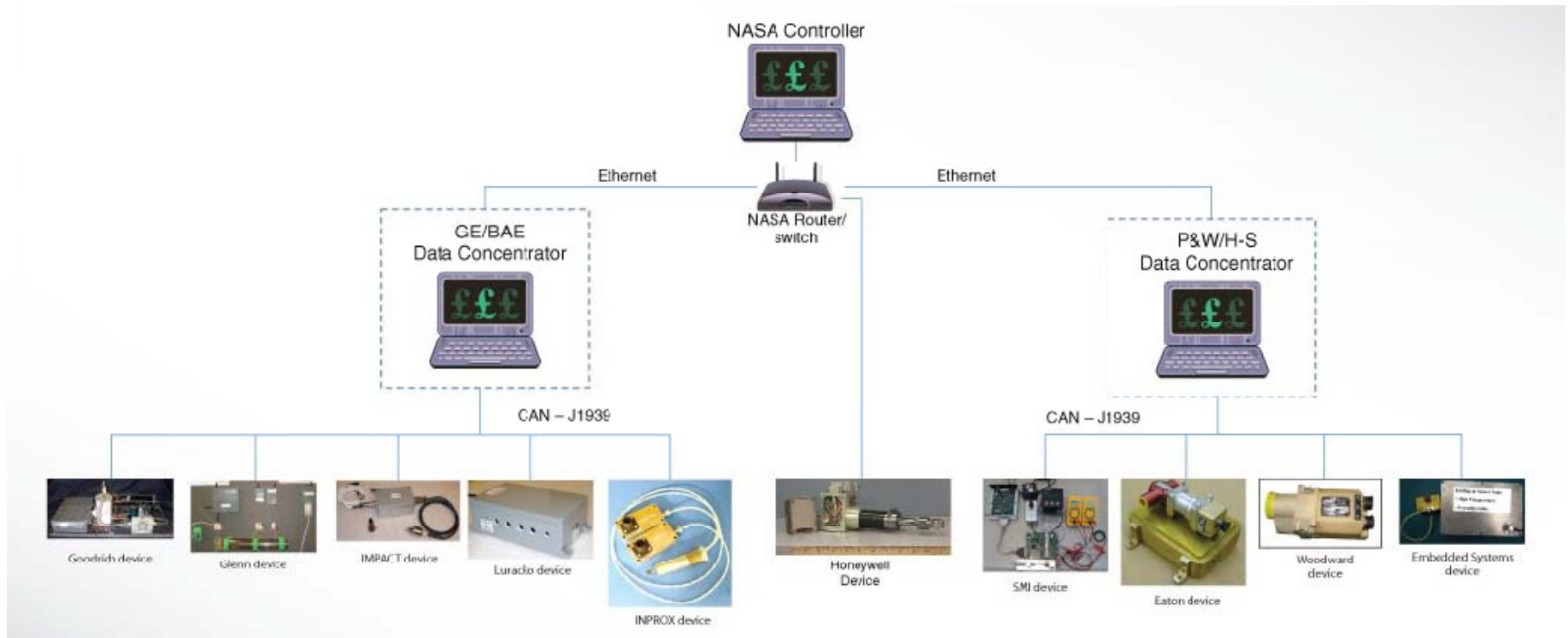

The demonstration will be on display in the NASA exhibit

DECWG

Distributed Engine Control Working Group

Approved for Public Release



DECWG

Distributed Engine Control Working Group

Approved for Public Release

Contributors to the Demonstration

BAE Systems

Eaton Corp.

Embedded Systems, LLC

General Electric

Goodrich Corp.

Hamilton Sundstrand

Honeywell

Impact Technologies, LLC

Inprox Technology

Luraco Technologies

NASA

Pratt & Whitney

Scientific Monitoring Inc / Haric, LLC

Woodward Governor Company

Vision and Need for Future Turbine Engine Control

**Bruce Wood
Brian Easton
Pratt & Whitney**

**Bill Mailander
GE Aviation**

**Alireza Behbahani
Air Force Research Laboratory**

DECWG

Distributed Engine Control Working Group

Approved for Public Release

11

Technical Requirements for Distributed Controls

Physical Drivers for New Control System Designs

- Thermal Environment
- Externals Packaging
- Rapid Reconfiguration / Upgradability
- Generic Physical/Functional Interface
- Environmental Requirements
- Certification Impact
- Integration Testing
- Financial Responsibility

Focus on Near-Term Applications

- Concentrate on commercial applications with production volumes
- Design for maximum leveraging though multiple applications

Technical Requirements for Distributed Controls

Thermal Environment

- Design electronics to withstand existing hardware thermal conditions
- Recognize limitations of typical industry materials
- Aluminums (300F/149C), Elastomers (350F/177F)

Externals Packaging

- Need to integrate electronics onto or within existing hardware
- Minimize unique hardware
- Adding new/extra mounting hardware drives cost, weight in the wrong direction

Technical Requirements for Distributed Controls

Rapid Reconfiguration / Upgradability

- Should be able to specify same part number DCM for multiple applications
- Design DCM internal gains such that they can be varied without hardware changes

Generic Physical/Functional Interface

- Similar to the way EHSV interfaces are controlled today (ARP490)
- Bolt/connector interfaces should be standardized
- Standard functionality, memory, loop closure, communication bit structure, etc.

Technical Requirements for Distributed Controls

Environmental Requirements

- Design for existing ambient temperatures and vibration environments
- Don't drive cost/complexity into the DCM to withstand unrealistic margins
- Focus on actual engine environments, not D0160/810 generic requirements

Certification Impact, Changes to Testing

- Allow certification at modular level
- Require system level certification using black box approach to testing
- Allow flexible system expansion/contraction without recert. required

Technical Requirements for Distributed Controls

Integration testing

- System integration testing paradigms will shift
- System integration tasks will shift one layer down the food chain
 - AS/OS boundaries may drive testing location, integration responsibilities

Financial responsibility

- Need to keep focused on cost of products, don't design and build beyond our minimum needs (with reasonable margins)
- System costs need to make the case for this new technology
 - Individual component costs are flexible
- Design + Development + Certification + Procurement + Life Cycle Cost = Net Savings for our Customers

Economic Drivers for New FADEC Designs

FADECs Have Unique Electronics Hardware Requirements

Issues

- High Temperature Capable Electronics for FADECs Are Specialty Items
- ~20 Years FADEC Production Runs vs. Rapid Consumer Electronics Turnover
- FADEC Electronics Often Nearing Obsolescence At Entry Into Service
- “Out-of-Plan” FADEC Obsolescence Turns Are Major Budget Challenge

Implications for Future FADECs

- Improved Methods for Enabling Electronics to Tolerate Engine Environment
- Use of Common FADEC Electronics Components Supply Base
- Exploration of Boutique Manufacturing Supporting Small Quantity Electronics

**Need Broadly Applicable
High Temperature Electronics Supply Base**

Economic Drivers for New FADEC Designs

Not Realizing Cost Benefits from Reuse / Upgradability

Issues

- Point-Designs Typically Increase Initial Cost and Reduce Production Costs
- Upgrades Can Cost As Much As Original FADEC Implementation
- FADECs Are Not Designed with Reuse in Mind – No “Pay-It-Forward”

Implications for Future FADECs

- Need to Consider Life Cycle Business Case in Design
- Partitioned Architectures Limiting Necessary Re-Validation
- Modular and Reconfigurable FADEC Components / Architectures

Point-Design FADECs Don't Support Reuse / Upgradability

Economic Drivers for New FADEC Designs

FADEC Implementation Time Pacing Engine Development

Issues

- FADEC Definition Usually Lags Engine Definition in Preliminary Design
- Long Development and Validation Times Consumed by for FADECs
- Weight / Cost Reduction Campaigns Drive FADEC Iterations

Implications for Future FADECs

- Move Away From Point-Design FADECs
- Leverage Common FADEC Components / Modules
- Safety First / Understand Trades Cost and Weight Trades

Modular FADEC Designs Favor Rapid Implementation

The Process for Distributed Controls

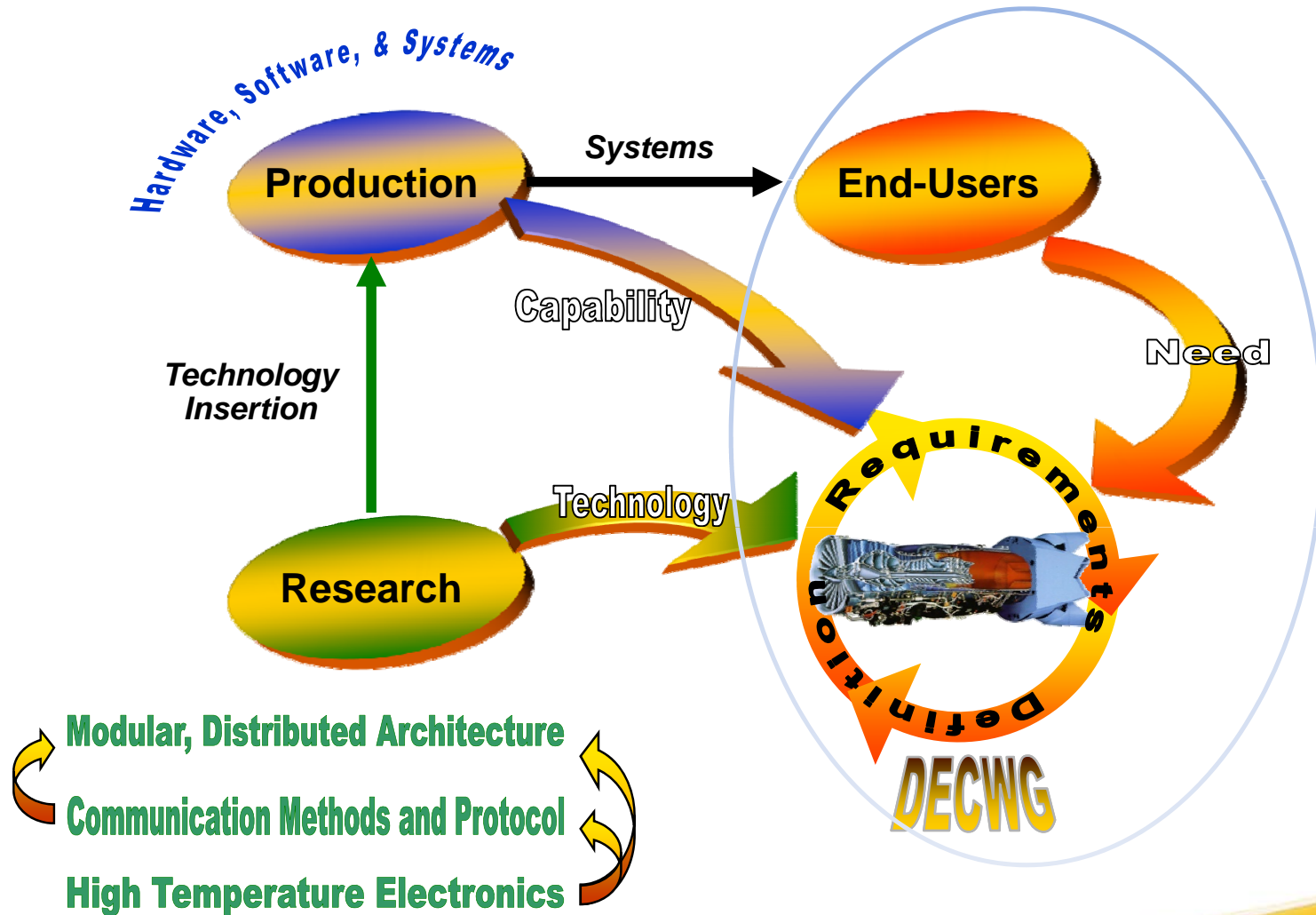

DECWG

Distributed Engine Control Working Group

Approved for Public Release

20

Objective: Modular, Open, Distributed Engine Control

Technology Benefits

➤ Increased Performance

- Reduction in engine weight due to digital signaling, lower wire/connector count, reduced cooling need
- 5% increase in thrust-to-weight ratio

➤ Improved Mission Success

- System availability improvement due to automated fault isolation, reduced maintenance time, modular LRU
- 10% increase in system availability

➤ Lower Life Cycle Cost

- Reduced cycle time for design, manufacture, V&V
- Reduced component and maintenance costs via cross-platform commonality, obsolescence mitigation
- Flexible upgrade path through open interface standards

Capability Needs

➤ Open Systems Development, Modeling & Design

- Future systems requirements definition
- Open industry interface standards definition
- System modeling tools development
- Modular system integration and test techniques

➤ Hardware Systems Development

- High temperature integrated circuits and systems development
- Improved electronic component availability

➤ Software Systems Development

- Software system partitioning
- Software design and modular test capability
- Software distributed system V&V

Who Is The Customer For Controls?

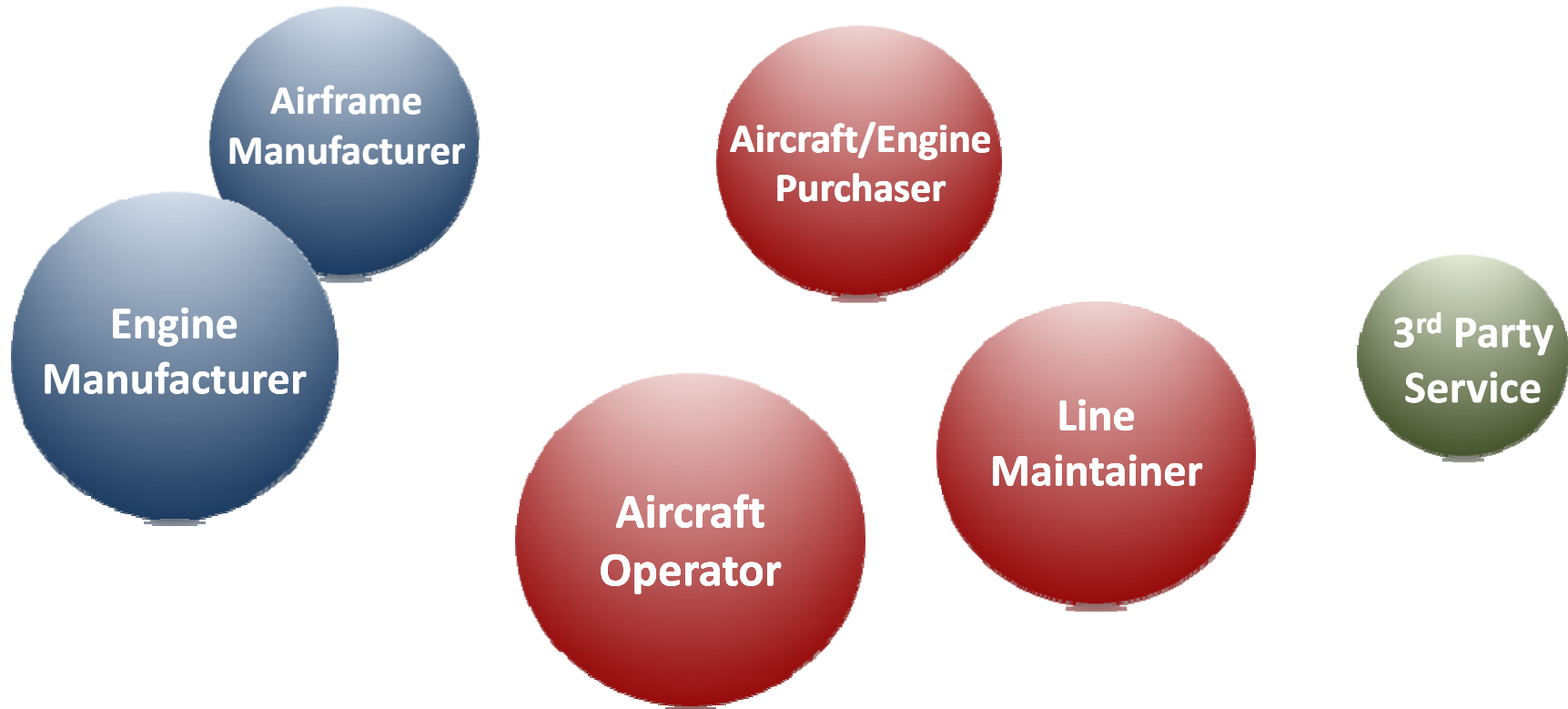

What Control Attributes Do Customers Value?

Engine Manufacturer

There is a need for improved control devices that are compatible with the control electronics made by different manufacturers. In addition there is a need for specific purpose control devices of one manufacturer to be compatible with more general-purpose control electronics from a different manufacturer.

adapt the system to your *needs*
(Customer Requirements)



Airframe Manufacturer

Mission, Vehicle , and Customer/OEM Requirements

There is a need for control integration between engine , TMS, power, and the aircraft. An iterative process to meet all requirements including customer and engine requirements.

An integration Process with Interactive Approach

Adapt the system to your customer's and OEM's *needs*



Aircraft/Engine Owner

There is a need for improved autonomous control devices that are compatible with the control electronics made by different manufactures. The big issue is the cost and obsolescence the aircraft and engine owners need to achieve the minimum cost of maintaining their assets

Adapt the system to your *needs at lowest cost*

Performing maintenance and repair on the flight line or in the depot will have reduced cost for a distributed control architecture, since any maintenance issues are easily identifiable.

Cost
(Development, production, maintenance)

Thrust/Weight

SFC

**Reliability
Dependability**

Capability

Performance

Maintainability

A set of user interfaces needs to be developed to allow a single user to efficiently control the fleet of aircraft. Their impact and benefit derive from the convergence of new DEC architectures

DECWG

Distributed Engine Control Working Group

Approved for Public Release

25

Comparison:

Commercial

vs.

Military

- GE & P&W each build 500-1000 Jet engines annually and build replacement parts for 17000 engines
- Distributed control design will increase COTS, reduce inventories, and reduce cycle time for design, manufacture, V&V, and cost
- Military engines push the SOA technologies
- To maintain adequate military capabilities in the years ahead, the US will have to design, develop, and produce defense systems with the needed performance at more affordable costs
- Embedded military S/W for controls must handle enormously complicated integration tasks. DEC solution offers common S/W & H/W for both military & commercial engines
- To extend or change control system capability to handle complicated tasks, designers must modify the H/W, S/W, and improve fault tolerance and fail-safe operation
- S/W can implement functions that would be extraordinarily time-consuming & costly in H/W alone

Comparison:

Large Engines

vs.

Small Engine

- Large engines and small engine classes have unique S/W H/W requirements
- The current commercial airline and military “bear market” is leading the “Big Four” to engage on more partnership and collaboration with each other and with small engine manufacturers
- The current military aircraft UAV procurement means more new development for the small turbine engine
- For the next several years, strengths in the turbine engines sector are expected to continue to come from increased military fighter aircraft and UAVs
- A DEC is the methodology to improve engine performance & cost
- In addition to manufacturer collaboration and R&D programs, several important market factors present challenges that are stimulating significant improvements in engine technology

Transition:

Commercial

vs.

Military

Commercial to Military

- Military demand is growing for FADEC & control systems with expert systems embedded in the S/W for fault tolerance.
- Civilian demand has spurred rapid technological progress for commercial aircraft.
- Escalating procurement and fuel costs will stimulate the DoD to leverage commercial FADECs & control systems S/W & H/W.
- Modular / Universal/Distributed design can reduce development time and cost. S/W could offer baseline for military-qualified FADECs.
- To promote dual use, the services must recognize the similarities between commercial applications & military needs; too often, they focus on the differences

Military to Commercial

- Avionics has been the chief success story in transferring military S/W and hardware to civil sector. Through VAATE and SBIR funding a lot of technologies has been transferred to commercial avionics.
- Modeling & real-time SIMULATION can reduce integration cost for both commercial and military engine controls
- Technology transfer also occurs from both commercial & military programs

What Does “The Customer” Value?

Engine: Pays Cost of FADEC Development/Production
FADEC Weight / Size Impacts Engine Design

Airframe: FADEC Impacts Aircraft Capability / Integration

Manufacturers



Operational Costs



Marketability

Aircraft/Engine Purchaser: Responsible for FADEC Repair Cost

Aircraft Operator: Impact of Failures i.e. Delays/Cancellations

Line Maintainer: Labor/Materials FADEC Troubleshooting & Repair

Typically
Airlines



Transfer Risk

3rd Party Service Providers: Pay for FADEC Repair & Impact to Airline

Weighting of Values Vary By Engine Application

Purchase Cost / Weight

Increasingly Valued As Engine Size Decreases

Control System As Percentage of Total Engine Weight/Cost

Engine Manufacturer Values

Often Transfer to Military Customers

*DoD Owns Engine Design – Often Responsible for Development /
Production Costs*

Reliability

Even More Critical for Smaller Airline Fleets

Fewer Aircraft Means Fewer Options When One is Down for Maintenance

How Can FADEC Impact Customer Value?

Reduce Overall Control System Weight

Consider Electronics, Power Supplies, Housings, Connectors, Harnesses, etc.

Enable Reuse and Upgradability of FADEC Components

Provide Head Start on FADEC For New Applications

Improved Control System Component Reliability

Robustness Against Steady and Cyclical Temperature and Vibrational Effects

Easier Control System Troubleshooting and Repair

Reduced Training and Labor Hours via Automation

Implementation and Technology Challenges To Achieve the Vision

Bill Rhoden
Hamilton-Sundstrand

Casey Carter
BAE Systems

DECWG

Distributed Engine Control Working Group

Approved for Public Release

31

Considerations for Power Distribution in a Distributed System

- Currently in most centralized engine control systems the Power Supply Unit (PSU) is embedded into the FADEC or ECU
- PSU volumes can account for 25% to 40% of the total FADEC/ECU volume
- Power is classically supplied to the ECU by either an 115VAC or 28VDC aircraft input or from the Permanent Magnet Alternator (PMA)
- Energy harvesting for remote modules currently not seen as robust or reliable enough for a critical engine control system, therefore a dedicated PSU should be used to power the remote modules
- The power requirements for remote modules may vary depending on function/capabilities of the module (e.g. actuator driver vs. simple smart sensor)

Power Distribution Concepts

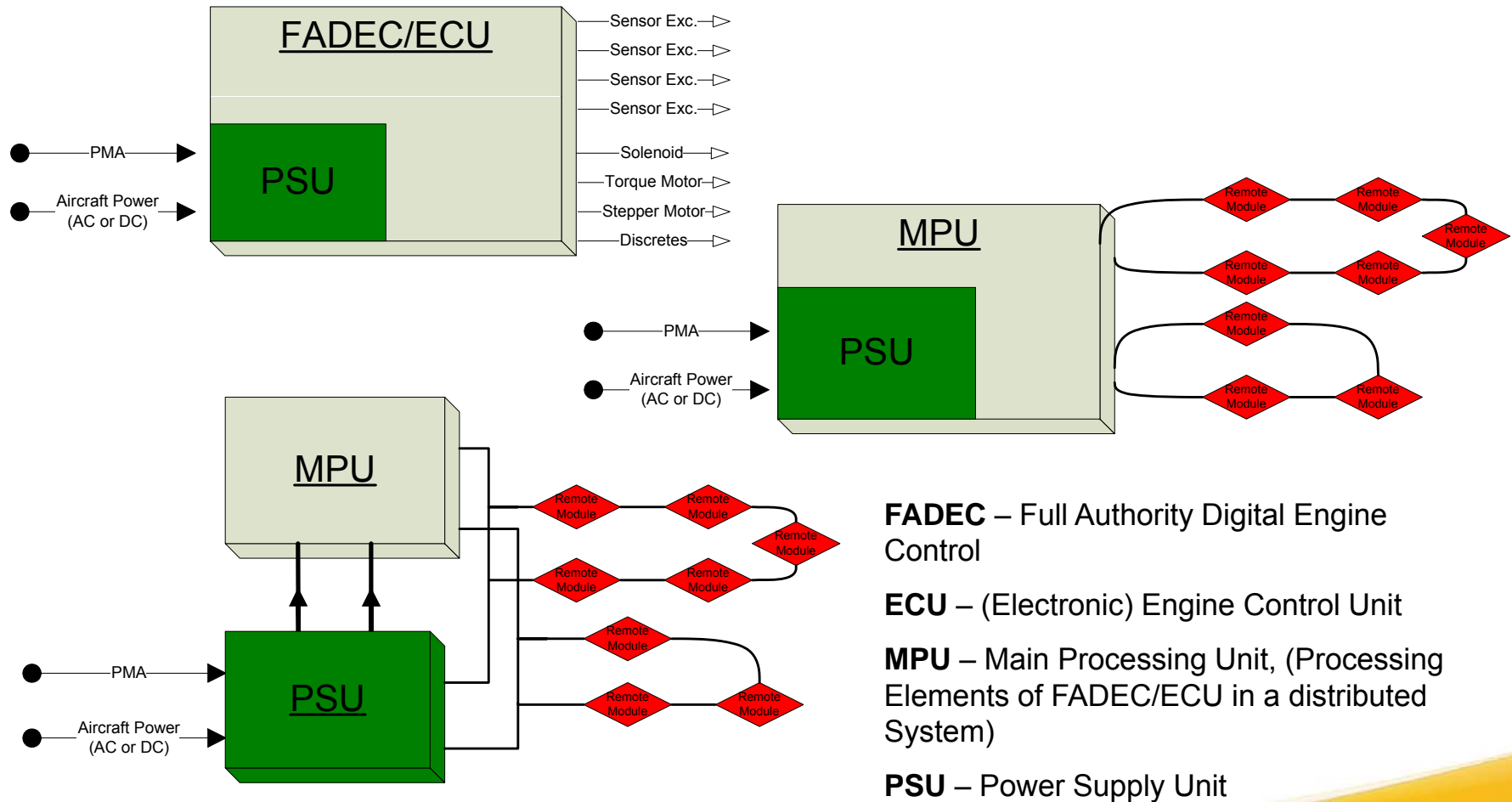

Considerations for an Engine Area Network

- Can a Commercial Off the Shelf (COTS) serial bus be used for an Engine Area Network (EAN) solution that supports an open distributed control architecture?
- Several busses exist from the industrial, automotive and aerospace control market areas. Which would be the best fit?
- Need to, as an industry, define the required performance requirements based on several distributed control topologies
- Key selection criteria should include:
 - Bandwidth
 - Compatibly with current high temperature electronics capability
 - Predictable communication response times between master and remote modules (deterministic)
 - Latency
 - Supports multi-drop physical layer
 - Low Cost
 - Minimal obsolescence risk
 - Stability of standards

Engine Area Network Selection Conclusions

- Does any one bus meet all of the selection criteria?
- Published studies and customer responses have shown a desire for a multi-drop bus topology (as opposed to star, ring, etc.) since it has been theorized to optimize cabling weight savings
- The current availability of High Temperature Electronics (serial bus physical and logical devices) is seen as the largest divider for a EAN bus selection
- Identification, detection and handling of faults also needs to be considered
- DECWG partners should work together to define a single bus protocol and physical layer options that support open distributed engine control architectures

Are there High Temperature Electronics
to support the bus physical layers?

A Current View of High Temperature Electronics Market Space

- High Temperature Electronics is currently a niche market with a limited list of available components which are usually costly and with limited life and reliability... but evolving quickly
- Currently aligned to drilling or “down hole” application requirements that do not necessarily overlay with avionics requirements
 - Focused on remote sensing oriented and not actuation
- Some transfer of radiation hardened technology to high temperature
- Published avionics quality reliability data
 - Data is currently lacking even for some high temperature components
 - SEU and SEL Data availability
- Avionics component life and pricing needs are not met with current offerings
- Strongly suggest that DECWG work with electronics vendors and start to compile a list/library of available components to support future high temperature distributed controls development

What is the avionics that engine and aircraft operators are willing to live with for the price to improve efficiency and flexibility?

High Temperature Electronics Needs

- Predicted temperature range limits: -55°C to $> +200^{\circ}\text{C}$
 - This reflects what is currently available with SOI technology
 - Estimate modules would be exposed to max temps 80-90% of life
 - Studies from engine OEMs could expand/contract temperature and duty cycle estimates
- Longer Life and Reliability
 - Current engine controls have long life requirements
- Competitive Cost
 - What are the sustainment cost or total cost of ownership benefits of a distributed system compared to a centralized system?
 - Current component cost is approximately 10 - 20 times that of equivalent military temperature parts
- Long Term Component Availability
 - Approximately 20 years
 - Can high temperature device vendors manage product obsolescence better than current commercial devices to decrease life cycle costs?
- Example Component Needs
 - Larger FPGAs, Processors, Micro-Controllers
 - Serial Bus Logic Layer and Physical Layer Controllers
 - ADC and DAC
 - PWB

FAR Part 33 Certification Rules

- Section 33-28 Electrical & Electronic Engine Control Systems
 - Loss of Aircraft Power or Data – No unacceptable change in thrust
 - Channel 1 to Channel 2
 - One control mode to another
 - Primary to Back-up control
 - Single-Point or Probable Combination Failures
 - Software Design & Implementation to prevent errors
- Section 33-75 Safety Analysis
 - Hazardous (10^{-7} to 10^{-9}) and Major Engine Effects (10^{-5} to 10^{-7})
 - Thrust changes
 - Erroneous Data Transmissions
 - Surge / Stall
- Section 33-83 Vibration Tests

FAR Part 33 Certification Rules

- Section 33-87 Endurance Tests
 - Engine control controlling the engine
- Section 33-91 Engine Component Tests
 - Temperature Limits
 - Fire Proofing
 - Sea Level to Altitude Testing
 - Salt Spray/Humidity/Fungus/Explosive Atmosphere
 - Electromagnetic Compatibility (EMC)
 - High Intensity Radiated Field Compatibility (HIRF)
 - Lightning Tolerance
 - Software Validation (DO-178B)
 - Control Integrity under degraded modes

Considerations for Certifying a Distributed Engine Control Architecture

- Different from the Norm
 - Failure Modes
 - Loss of Power
 - Single Point/Multi Point Failures
 - Software
 - Unintended Interactions
 - Latency
 - Data Integrity
 - Increased Connections
 - Reliability
 - Potential Harsher Environment
 - Smart nodes in hot section
 - Communications Protocol(s)
 - Coordination of multiple protocols?
 - EMI/HIRF/Lightning Susceptibility
 - Software Validation (DO-178B)
 - Dispatchable failures?

As Good As Current Architecture

High Temperature Electronics

Dewey Benson
Honeywell

Gary Hunter
NASA Glenn Research Center

DECWG

Distributed Engine Control Working Group

Approved for Public Release

41

High Temperature Electronics for Distributed Controls

Issues

- High temp electronics have been the “show stopper” in past attempts
 - Lack of available parts to make a full distributed node
 - Difficulty of getting non-volatile memory to work at high temp
 - Cost of solutions
- User community wants the same cost as low temp electronics
- Compact size desired

Trade-offs

- Standard silicon solutions versus Silicon-On-Insulator (or Sapphire) or SiC
- Build up solutions from discrete parts or develop custom chips (ASICs)
- Temperature capability versus reliability

Specific application needs could dictate different solutions

Standard Silicon versus Silicon On Insulator

- Buried SiO₂ (SOI) Insulating Layer

Provides:

- High Temperature Operation 225°C continuous and excursions to 300°C
 - Ultra High Reliability
 - 30% To 40% Faster Circuits
 - 30% To 40% Lower Power
 - Better Isolation For Mixed Signal ASIC
 - Improved Sensor Accuracy And Stability
- SOI wafer cost is higher
 - Process complexity of Bulk Silicon and SOI is similar
 - Low leakage is key to non-volatile memory

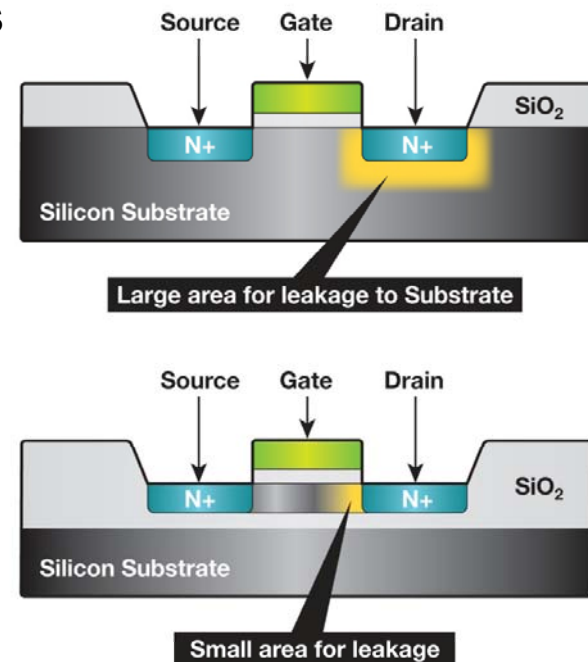

It Starts With The Base Silicon Technology!

Problems With Electronics At High Temperature

- **Issue 1: PN Junctions Leak!**
 - Junction leakage doubles every 10°C (above $\approx 170^\circ\text{C}$)
- Silicon Solution: Physically greater separation between junctions
- SOI Solution: Glass or Sapphire provides higher dielectric. i.e. lower leakage

- **Issue 2: MOS transistors leak!**
 - Sub-threshold conduction increases with temperature
 - Standard commercial SOI processes leak badly above 150°C
- Solution: Increase transistor threshold voltage implants to compensate

- **Issue 3: Aluminum Inter-connects “move”!! (electromigration)**
 - Strong function of temperature and current
- Solution: Reduce average current density to gain high-temp. reliability
- Solution: Increase interconnect area → Bigger footprint

Cost of SOI trades against lower leakage for similar gate spacing

High Temperature Standard Silicon Design

Example: Texas Instruments 24-bit A-to-D (ADS1278 & ADS1278-HT)

Low Temp (85C) Design
Die area ~1/2 of Hi Rel
ADS1217/1218

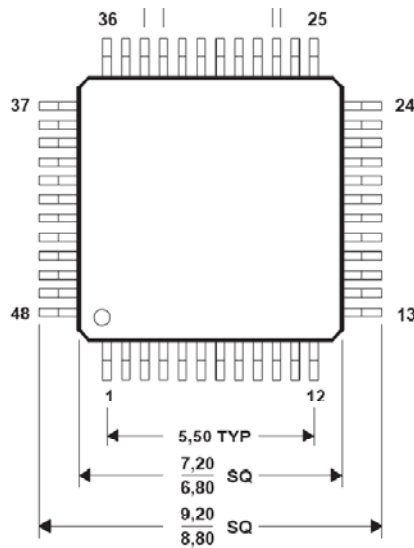

Hi Rel Design

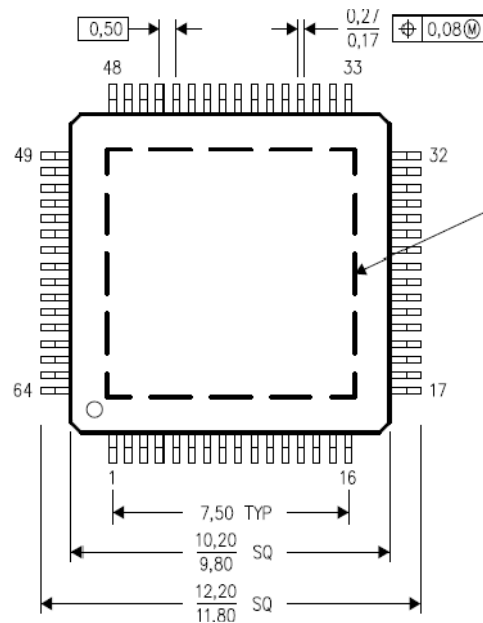

- High reliability part design
- Same die for 105C and 210C parts
- Screened for higher 210C temp range

Normal Hi Rel Part

- -40 to +105 C
- Plastic package
- Cost: \$24 Std parts \$4 - \$7

High Temperature Part

- -55 to +210 C
- Die only
- Cost: ~~\$5~~ ~~\$X0~~ ~~\$X5~~

Act Now! Special Offer!

\$125 per TI website

DECWG

Distributed Engine Control Working Group

Approved for Public Release

High Temperature Silicon Design

Texas Instruments High Temperature Parts Offerings

High Temperature (HT) Released Products

| Device | Function |
|---------------|---|
| SM320F2812-HT | 32-Bit Motor Control DSP |
| SN65HVD233-HT | 3.3-V CAN Transceiver |
| SN65HVD11-HT | 3.3-V RS-485 Transceiver |
| TPS62000-HT | High-Efficiency Step-Down Low Power DC-DC Converter |
| TPS76901-HT | Single Output LDO, 100mA, Adjustable |
| ADS1278-HT | Quad/Octal, Simultaneous Sampling, 24-Bit Analog-to-Digital Converter |

High Temperature Parts

- -55 to +210 C
- Ceramic surface mount or die only
- Minimum 1000 hrs life

High Temperature (HT) Roadmap Products

| Device | Function |
|------------------------|---|
| Data Converters | |
| ADS1282-HT | High Resolution Delta Sigma ADC with PGA |
| Power | |
| TPS62110-HT | Adjustable, 700-mA, 17-V Vin Step-Down Converter |
| TPS40200-HT | Wide Input Nonsynchronous Buck DC/DC Controller |
| Amplifiers | |
| OPA2333-HT | 1.8V, microPOWER CMOS Op Amp |
| OPA211-HT | Low Noise, Low Power, Precision Op Amp |
| OPA129-HT | Ultra-Low Bias Current Diff Operational Amplifier |
| INA117-HT | High Common-Mode Voltage Difference Amplifier |
| INA129-HT | Precision, Low Power Instrumentation Amplifiers |
| Reference | |
| REF5025-HT | Low Noise, Very Low Drift, Voltage Reference |
| Processors | |
| SM320F28335-HT | 32-Bit Floating Point Motor Control DSP |
| SM470R1B1M-HT | 60 MHz ARM7 μ Controller |
| MSP430F2619-HT | 16-Bit Ultra-Low-Power MCU (150°C) |

High Temperature Silicon Design

ADS1278 Operating Life Derating Chart

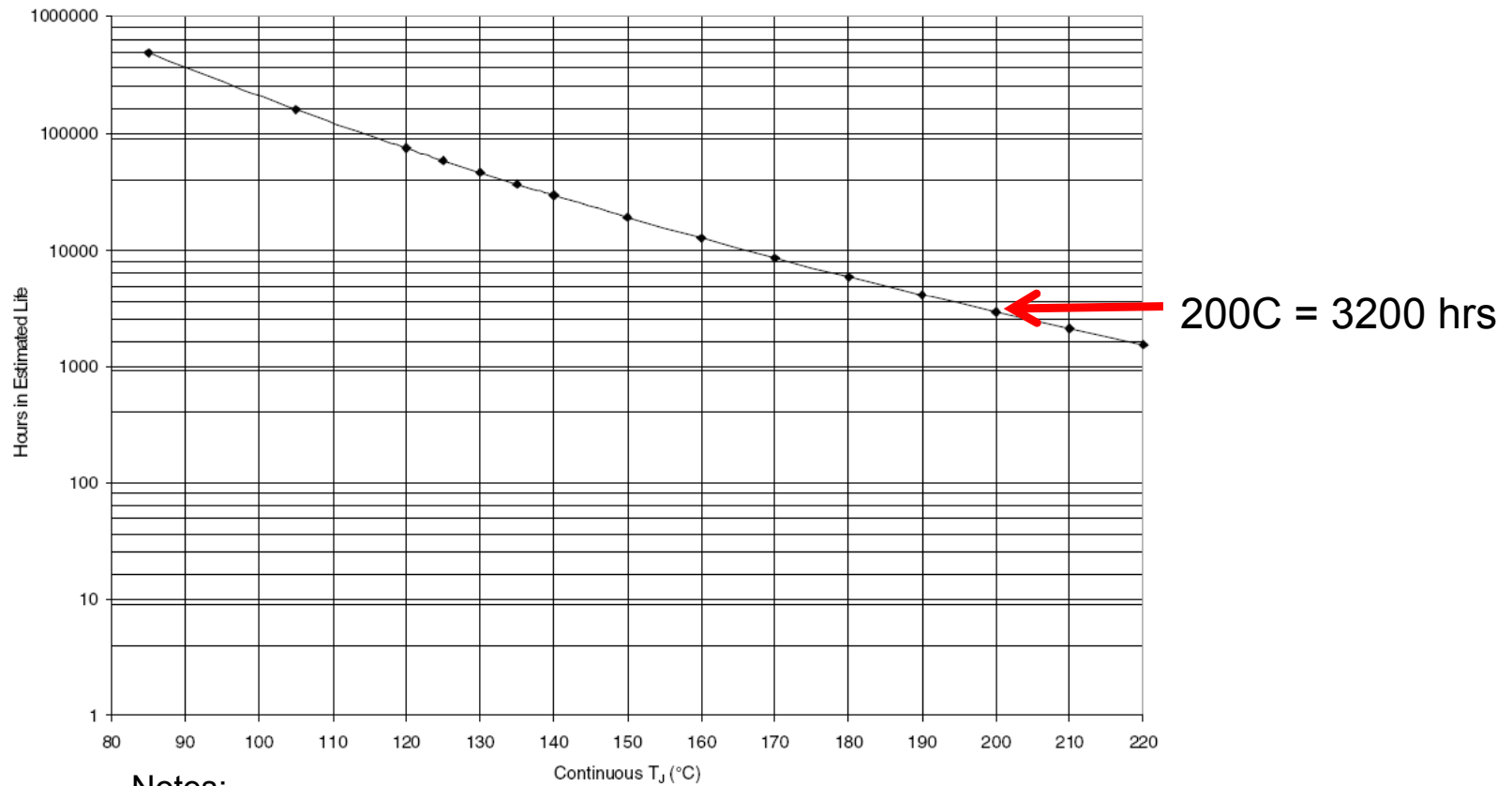

Notes:

- 1. See datasheet for absolute maximum and minimum recommended operating conditions.
- 2. Silicon operating life design goal is 10 years at 110°C junction temperature.
- 3. Courtesy Texas Instruments

SOI Operating Time vs. Temp

96,000 hours operation at 200°C, 1% Failure Rate
225,000 hours MTBF

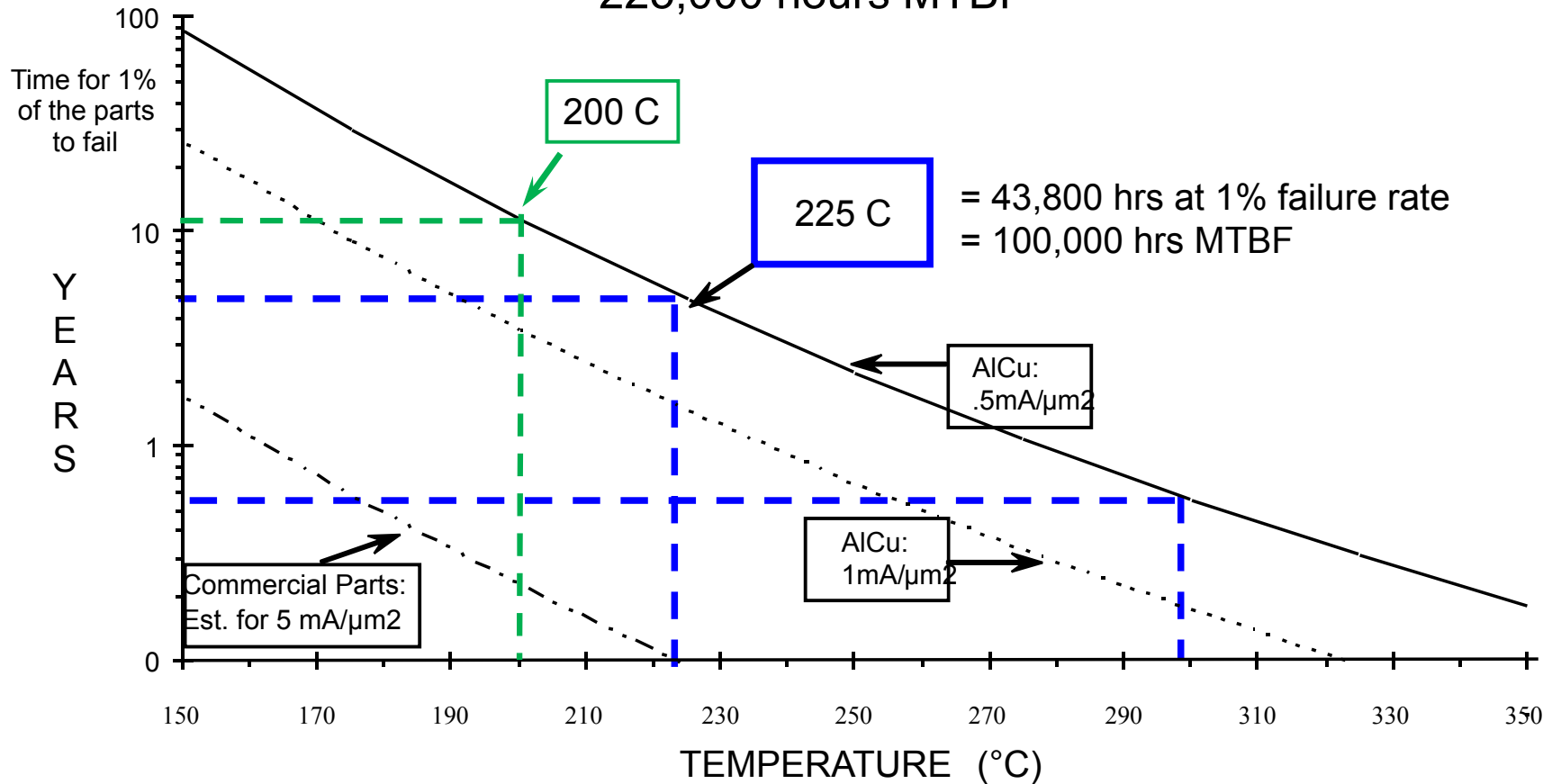

Operation Based on Temperature AND Time!

DECWG

Distributed Engine Control Working Group

Approved for Public Release

48

High Temperature SOI Part Availability

Standard Catalog Products:

- HTOP01 Dual Precision Op Amp
- HT1104 Quad Operational Amplifier
- HT1204 Quad Analog Switch
- HTPLREG Voltage Regulators
- HT83C51 8-bit Micro Controller
- HT6256 256Kbit SRAM (32K x 8)
- HT506 Analog Multiplexer (16:1)
- HT507 Analog Multiplexer (8:2)
- HTCCG Crystal Clock Generator
- HTNFET N-channel power FET

Custom Capabilities:

- Gate Arrays
- MCM (Multi-Chip Modules)
- High Temperature Design Services

Products in Development:

- HTA/D Converter (12 and 18 bit)
- HTEEPROM
- HTFPGA
- Reconfigurable Processor for Data Acquisition (RPDA)

2 Million Device Hours Worth
Of Life Test Data

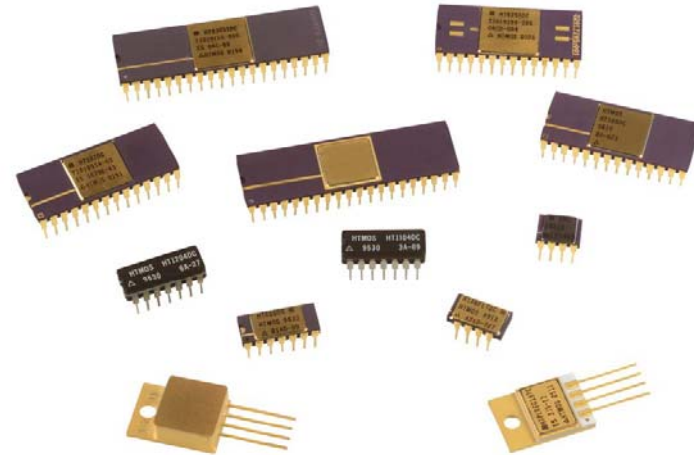

Key to flexibility: Non-volatile memory not perfect
(still needs occasional refresh):

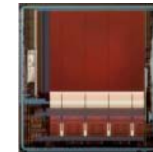
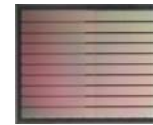
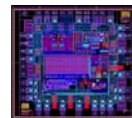

Parts portfolio expansion is slow & EXPENSIVE!

DECWG

Distributed Engine Control Working Group

Approved for Public Release

49

First Attempt At High Temperature Electronics

High Temperature Servoactuator Electronic Interface Unit (EIU)

Circa 1999, Funded by Air Force Research Labs

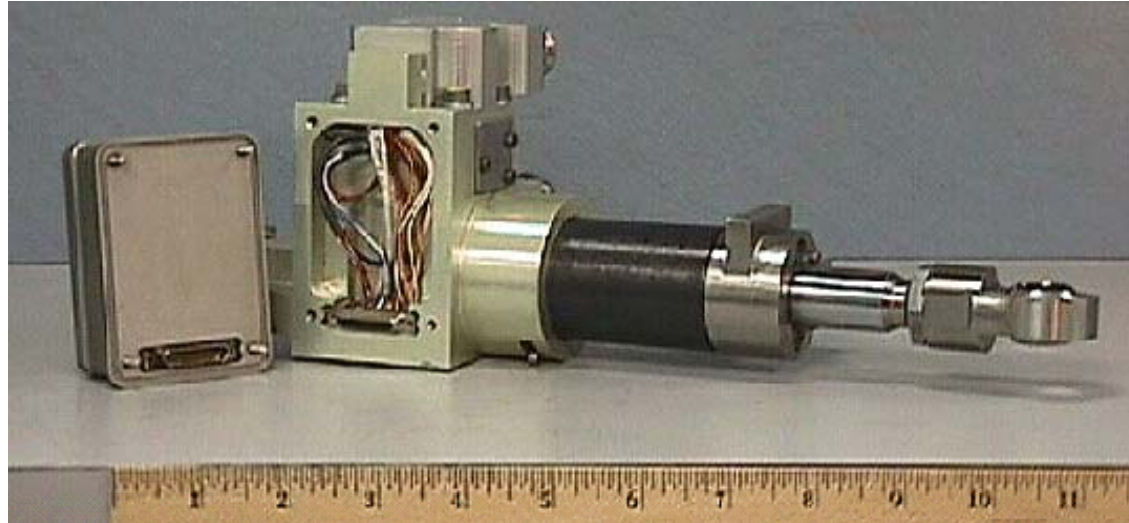

- Tested at 200C
- Microcontroller w/ BIT
- 1553 Interface
- PWM Torque Motor Drive
- LVDT Interface
- 0.57 lbs
- 1.2 x 2.3 x 3.4 inches

Biggest Negatives – Cost & Lack of Non-Volatile Memory

DECWG

Distributed Engine Control Working Group

Approved for Public Release

50

Take-Aways

How To Get The Most Out Of High Temperature Electronics

Issues

- High temp electronics will be more expensive:
 - If show-stopper, might as well stop now
- Each part is expensive, almost independent of part complexity
- Part cost driven by design cost, process development effort, and set-up costs
- Up-front costs too high for a single supplier to carry and hope to make a profit.

Industry response needed:

- Users need to define a cost point that still yields benefits
- Need consensus design for high temp nodes, then develop accurate estimate
- Incorporate into as few parts as possible to minimize cost → Custom ASICs
- Users, suppliers, and gov't share cost to develop high temp nodes
- Shared access to resulting products

**Will never overcome high development costs
without collaboration**

High Temperature Electronics for Distributed Controls

Issues

- ENGINE MANUFACTURERS FACE DEMANDS TO MEET THE INCREASING REQUIREMENTS FOR REDUCED EMISSIONS, REDUCED FUEL BURN, AND INCREASED SAFETY
- TO MEET THESE NEEDS THE INCLUSION OF DISTRIBUTED INTELLIGENCE INTO THE ENGINE DESIGN AND OPERATION BECOMES NECESSARY
- HOWEVER, ENGINES ARE HARSH ENVIRONMENTS. SPECIAL CHALLENGES INCLUDE:
 - OPERATION IN HIGH TEMPERATURE, HARSH ENVIRONMENTS WITH POTENTIALLY HIGH VIBRATION
 - MINIMAL SIZE, WEIGHT, AND POWER CONSUMPTION
 - FAILURE MECHANISMS WHICH DO NOT SHUT DOWN THE VEHICLE



HARSH ENVIRONMENT TECHNOLOGIES NEEDED FOR NEXT GENERATION ENGINES

DECWG

Distributed Engine Control Working Group

Approved for Public Release

52

Intelligence included throughout the engine requires the development of High Temperature Electronics capable of prolonged operation

Key compressor and exhaust regions beyond realm of silicon

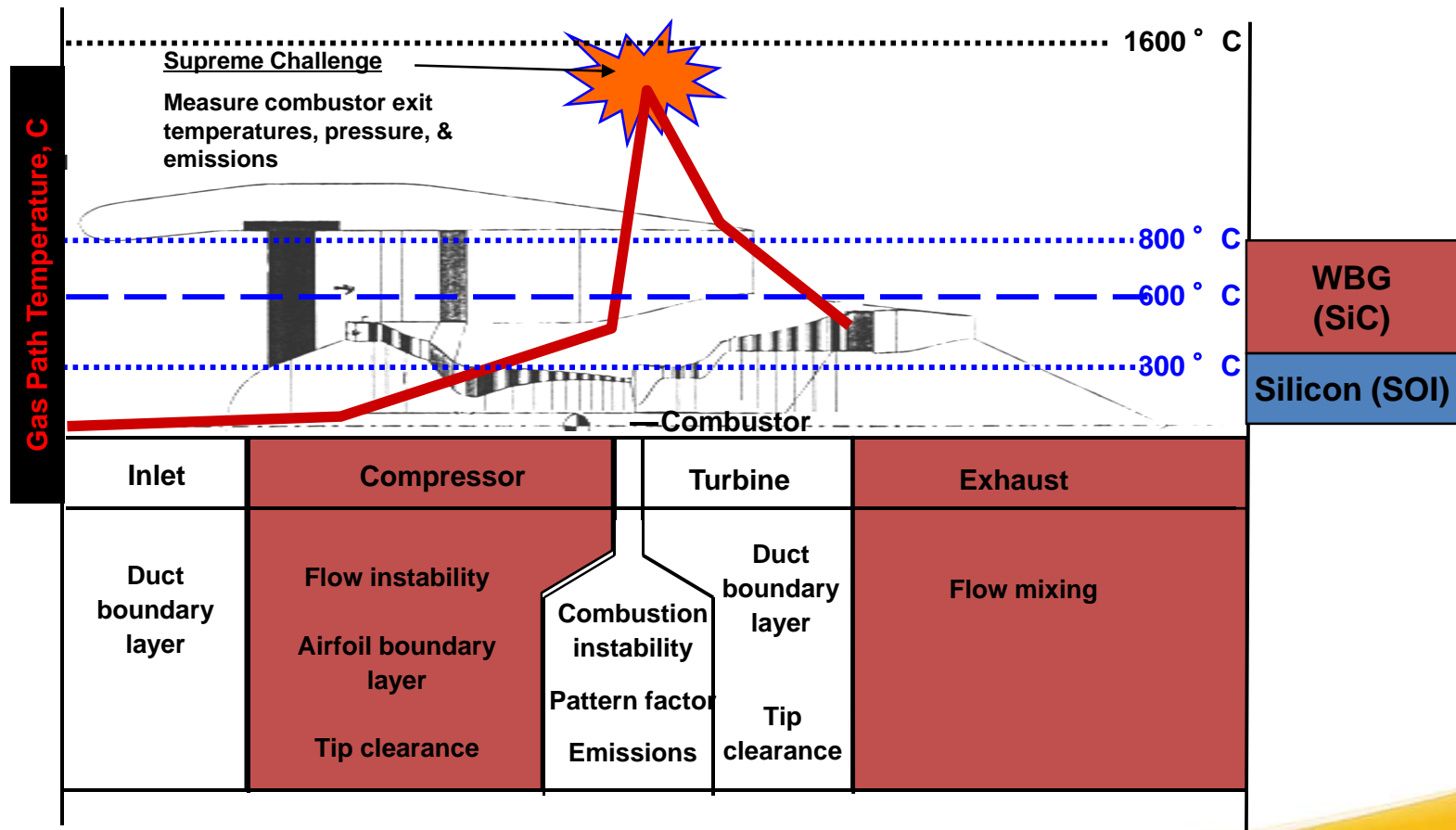

LONG TERM VISION

AVIONICS ARCHITECTURE VISION USING DISTRIBUTED SMART SYSTEM

- BASED ON INTELLIGENCE RESIDING WITHIN EACH DISTRIBUTED SMART SYSTEM CONTRIBUTING TO THE INTELLIGENCE OF THE COMPLETE SYSTEM
- ENABLE INTERNAL SYSTEMS TO MONITOR COMPONENT CONDITIONS, ANALYZE INCOMING DATA, AND MODIFY OPERATING PARAMETERS TO OPTIMIZE SYSTEM OPERATIONS TO ACHIEVE IMPROVED PERFORMANCE/RELIABILITY
- ELIMINATE VEHICLE SYSTEMS THAT REQUIRE INTENSE HUMAN INTERVENTION
- SMART SYSTEM TECHNOLOGY INCLUSION OFTEN PROBLEMATIC IN AERONAUTIC VEHICLE SYSTEMS
 - “TURN AND BURN”/MAKE IT SIMPLE
 - LEGACY SYSTEMS
 - CUSTOMER ACCEPTANCE
 - LONG-TERM VS SHORT TERM CONSIDERATIONS
 - LIMIT BURDEN ON VEHICLE

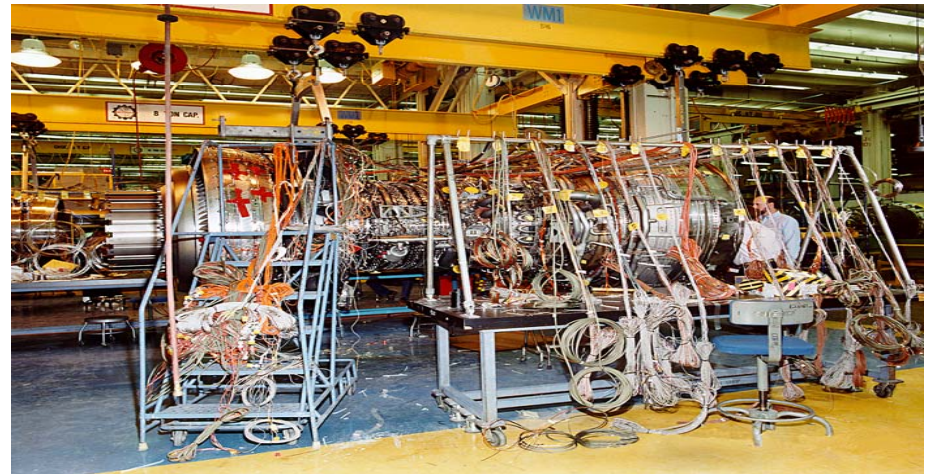

SMART DISTRIBUTED SYSTEM DEVELOPMENT

- THIS IS NOT JUST AN ELECTRONICS, SENSOR, ACTUATOR, COMMUNICATION, OR POWER ISSUE BUT AN INTEGRATED SYSTEM ISSUE
- COMPLETE MICROSYSTEM PACKAGE IS LONG-TERM OBJECTIVE
- IF A DISTRIBUTED SYSTEM IS GOING TO BE EFFECTIVE, THEN IT SHOULD BE APPLIED WHERE IT IS NEEDED, NOT JUST WHERE IT IS CONVENIENT
 - LIMITED ON-BOARD HARSH ENVIRONMENTS SYSTEMS LEAVING SIGNIFICANT AREAS OF THE PROPULSION SYSTEM UNMONITORED
 - FOR ENGINE APPLICATIONS, HARSH ENVIRONMENT MICROSYSTEMS NECESSARY

Microsystem Block Diagram

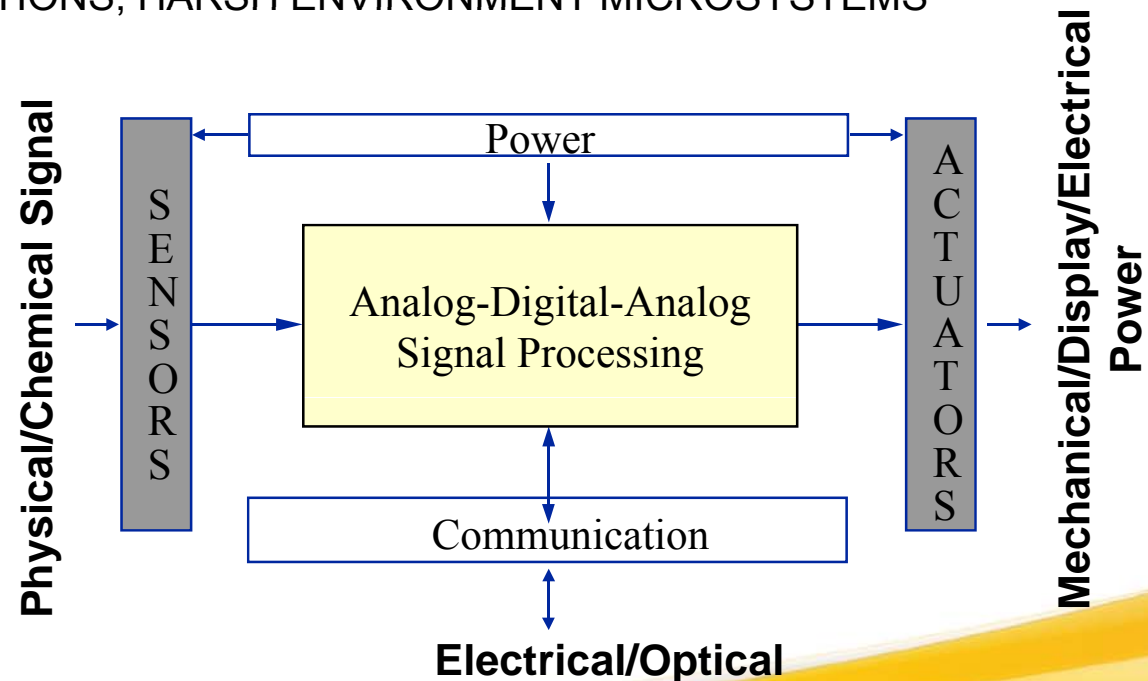

OVERCOMING RESISTANCE TO SMART SYSTEM IMPLEMENTATION

- DESIGN SMART SYSTEM FOR THE NEEDS OF APPLICATION
 - Deliverables/budget/time frame are typically application and vehicle dependent. Smart systems should be tailored for the specific application. Ideally, they should be included at the beginning of the design process rather than as an afterthought
- “LICK AND STICK” TECHNOLOGY (EASE OF APPLICATION)
 - Micro/nano fabrication to enable multipoint inclusion of sensors, actuators, electronics, and communication throughout the vehicle without significantly increasing size, weight, and power consumption. Multifunctional, adaptable technology included.
- RELIABILITY
 - Users must be able to believe the data reported by these systems and have trust in the ability of the system to respond to changing situations e.g. decreasing sensors should be viewed as decreasing the available information flow about a vehicle. Inclusion of intelligence more likely to occur if it can be trusted.
- REDUNDANCY AND CROSS-CORRELATION
 - If the Smart systems are easy to install, reliable, and do not increase weight complexity, the application of a large number is not problematic allowing redundant systems, e.g. sensors spread throughout the vehicle.
- SUPPORTING TECHNOLOGY OFTEN DETERMINE SUCCESS OF SYSTEM
 - Packaging, communication infrastructure, lead wires, mounting constraint etc. often dominant in whether a system can be successfully implemented.

HARSH ENVIRONMENT ELECTRONICS AND SENSORS

- NEEDS:
 - OPERATION IN HARSH ENVIRONMENTS
 - RANGE OF PHYSICAL AND CHEMICAL MEASUREMENTS
 - INCREASE DURABILITY, DECREASE THERMAL SHIELDING, IMPROVE IN-SITU OPERATION
- RESPONSE: UNIQUE RANGE OF HARSH ENVIRONMENT TECHNOLOGY AND CAPABILITIES
 - STANDARD 500°C OPERATION BY MULTIPLE SYSTEMS
 - TEMPERATURE, PRESSURE, CHEMICAL SPECIES,
 - HIGH TEMPERATURE ELECTRONICS TO MAKE SMART SYSTEMS
- SiC SEMICONDUCTOR ELECTRONICS UNIQUELY ABLE TO MEET THE NEEDS OF ENGINE APPLICATIONS

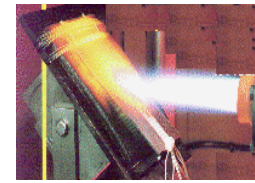

1998 R&D 100 Award

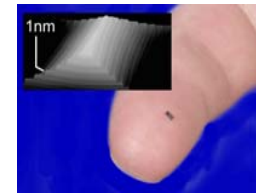

2004 R&D 100 Award

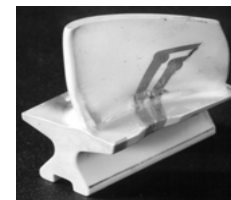

1995 R&D 100 Award



1991 R&D 100 Award

Range of Physical and Chemical Sensors for Harsh Environments



MICROFABRICATED SENSOR LOCATION

Harsh Environment Packaging (10,000 hours at 500°C)

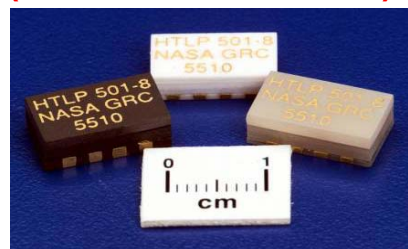

High Temperature Signal Processing and Wireless

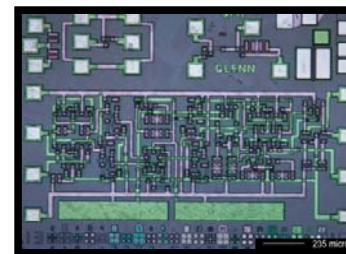

Long Term: High Temperature "Lick and Stick" Systems

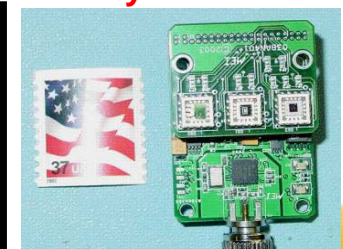

NASA Glenn Discrete SiC JFET Transistors:

First to Surpass 10,000 Hours of Stable Electrical Operation at 500°C

Current-voltage characteristics are very good and stable after 4000 hours

- Enables realization of analog integrated circuits (amplifiers, oscillators)
- Excellent turn-off characteristics, ON to OFF current ratio
- Enables realization of digital circuits.

Less than 10% change occurs during 10000 hours operation at 500° C.
- Most silicon transistor spec sheets list larger parameter variations.

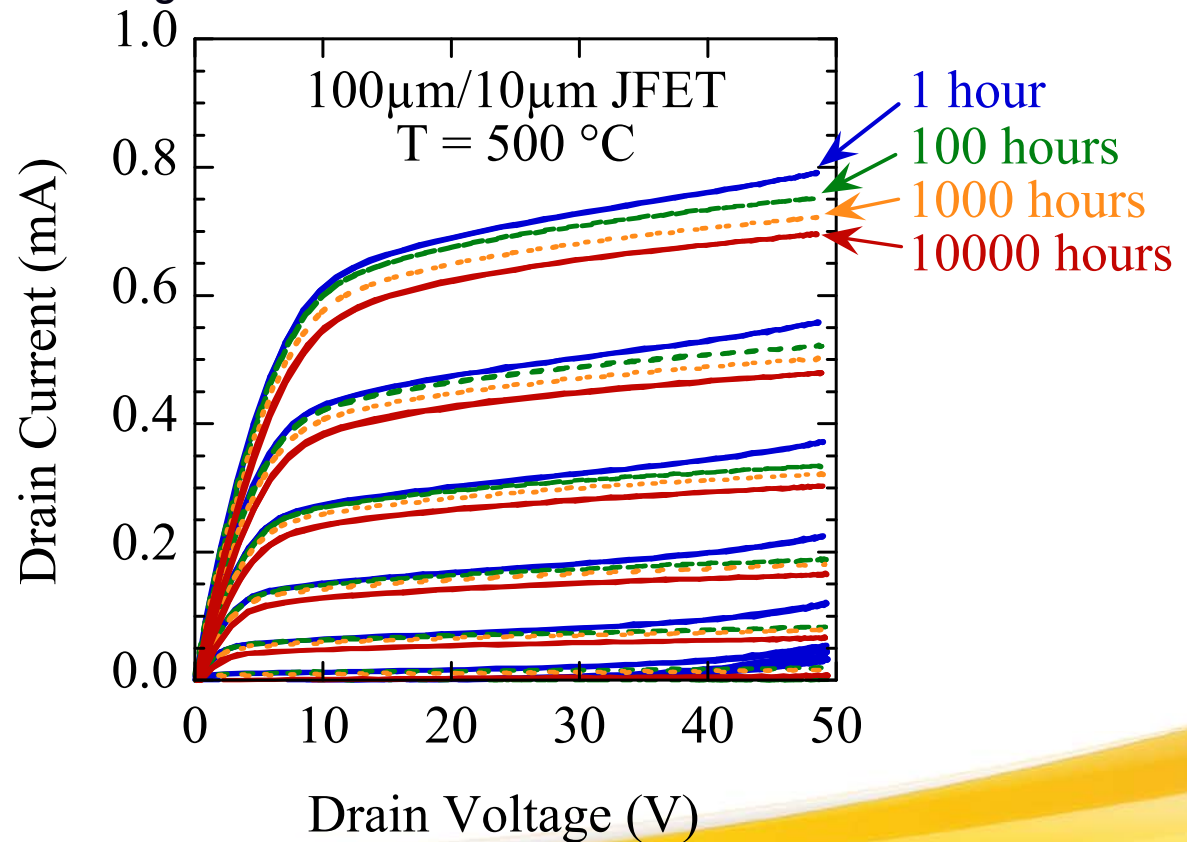

NASA Glenn Silicon Carbide Differential Amplifier

World's First Semiconductor IC to Surpass
5000 Hours of Electrical Operation at 500 ° C

Demonstrates CRITICAL ability to interconnect transistors and other components (resistors) in a small area on a single SiC chip to form useful integrated circuits that are durable at 500 ° C.

Optical micrograph of demonstration amplifier circuit before packaging

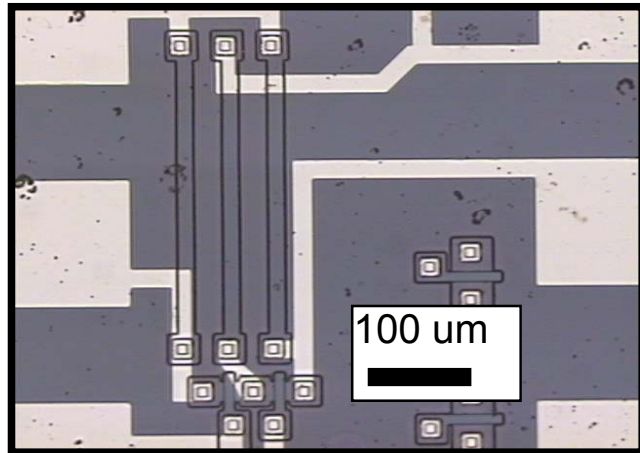

2 transistors and 3 resistors integrated into less than half a square millimeter. Single-metal level interconnect.

Test waveforms at 500 ° C

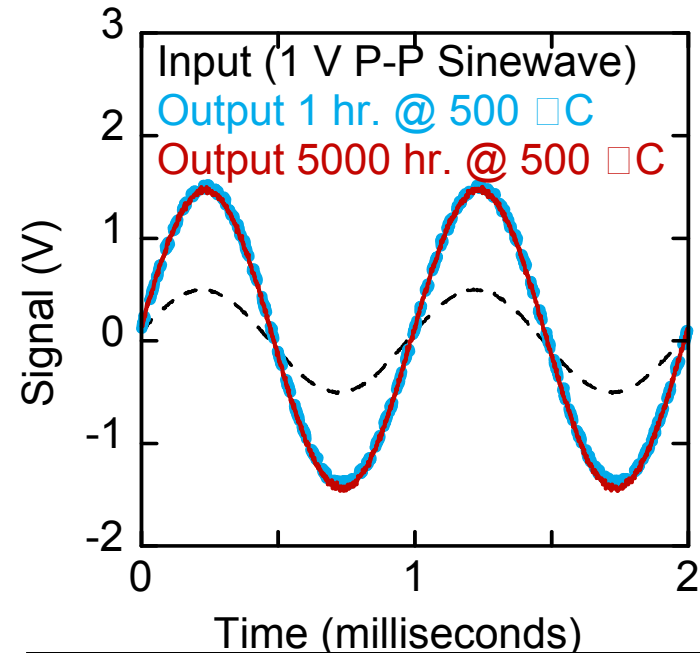

Less than 5% change in operating characteristics during 5000 hours of 500 ° C operation.

NASA Glenn SiC JFET NOR Gate IC

World's First Semiconductor Digital IC to Surpass 3000 hours of 500 °C Operation

With proper design, circuits function well over broad temperature range
Operation from 25 C to 500 C with no change to supply or logic voltages!

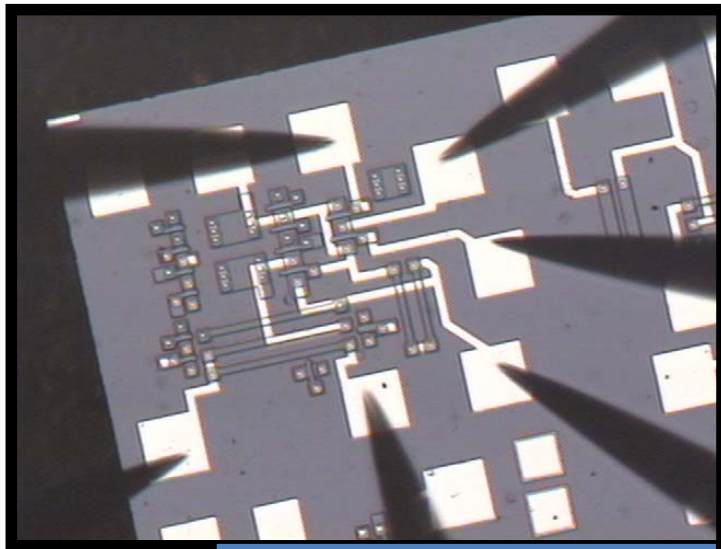

Probe-Test Photo

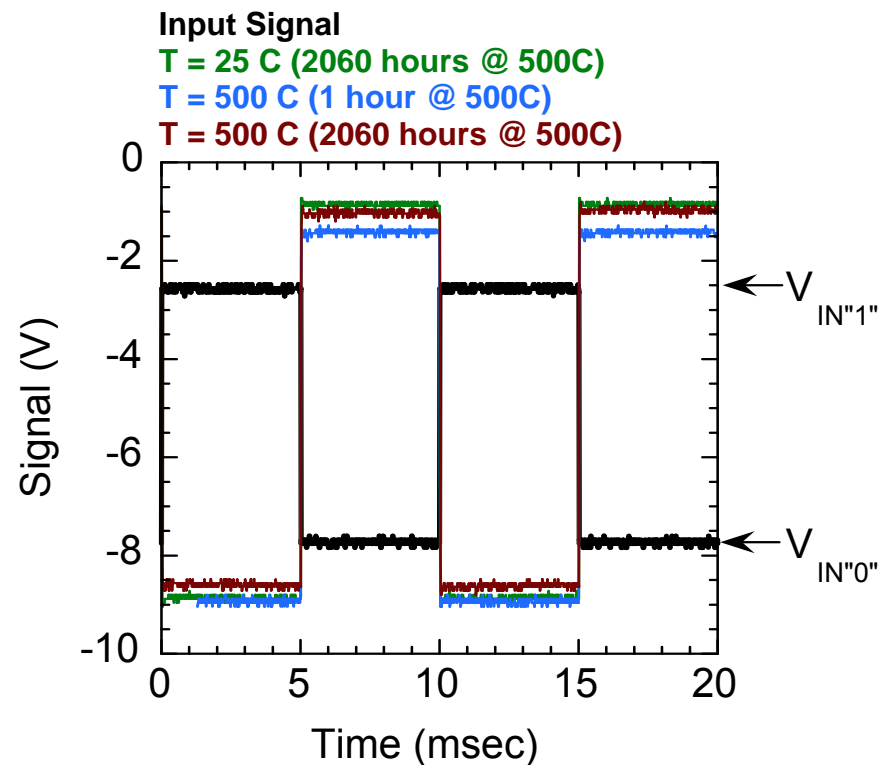

Digital Inverter Test Waveforms

SIGNIFICANCE OF RECENT ELECTRONICS RESULTS THE BASIC HARDWARE TOOLS FOR HIGH TEMPERATURE DATA PROCESSING HAVE BEEN FABRICATED

- ◆ **THESE RESULTS HAVE BEEN THE SUBJECT OF A HIGH LEVEL OF VISIBILITY E.G. NASA TOP 10 DISCOVERY STORIES FOR 2007**
- ◆ **DURABLE HIGH TEMPERATURE IC'S WILL ENABLE IMPORTANT NEW CAPABILITY**
 - Enabled by fundamental electronic materials research.
 - **World record IC durability at 500 °C (> 400-fold improvement).**
 - Inherently up-scalable to high circuit complexity while remaining physically small.
- ◆ **THIS DEMONSTRATION SHOWS THAT IT IS NOW POSSIBLE TO CONSTRUCT MORE COMPLEX CIRCUITS OPERATING AT 500°C AND MINIATURIZED.**
- ◆ **LOGIC GATES GENERATE FLIP-FLOPS THAT CAN GENERATE STATE-MACHINES TO ENABLE:**
 - Creation Of Control Electronics For An “Intelligent” Fixed Or Mobile Agent
 - The Configuration Of Intelligent Data Transmission Methods Allowing For Unambiguous Demodulation Of Signals Uniquely Associated With Each Sensor/Transmitter In A Network.

OBJECTIVE : TO MOVE TOWARD HIGHER DEGREES OF COMPLEXITY ALLOWING HARSH ENVIRONMENT SMART SENSOR SYSTEMS

Example System Demonstration:

Milestone: Demonstrate High Temperature Sensing, Wireless Communication, and Power Scavenging for Propulsion Health Management 8/30/2011

Metric: Demonstrate integrated self powered wireless sensor system at 500°C with data transmission with operational life of at least 1 hr

Significant wiring
exists with present
sensor systems

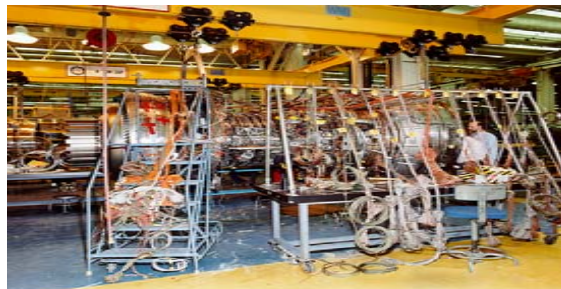

Allow Sensor Implementation by Eliminating Wires

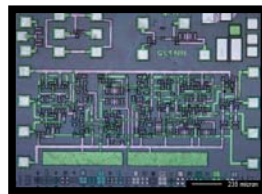

World Record High
Temperature Electronics
Device Operation

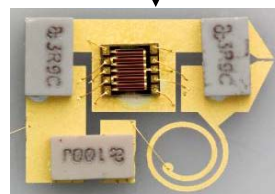

High Temperature RF
Components

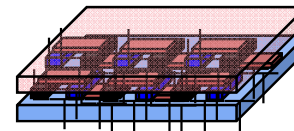

Energy Harvesting
Thin Film
Thermoelectrics

POTENTIALLY THREE STAGES OF INCLUSION OF ELECTRONICS, SENSORS, ACTUATORS, AND CONTROL LOGIC:

- 1) SYSTEM DEVELOPMENT AND GROUND TESTING WHERE THE SENSOR PROVIDES INFORMATION ON THE STATE OF A SYSTEM THAT DOES NOT FLY. THIS INFORMATION USED FOR THE DESIGN AND ADVANCED MODELING OF SYSTEMS THAT ARE USED IN FLIGHT
- 2) VEHICLE HEALTH MONITORING (VHM) WHICH INVOLVES THE LONG-TERM MONITORING OF A SYSTEM IN OPERATION TO DETERMINE THE HEALTH OF THE VEHICLE SYSTEM (E.G., IS THE ENGINE INCREASING FUEL BURN OR INCREASING EMISSIONS). THIS INFORMATION USED TO CHANGE ENGINE PARAMETERS TO IMPROVE PERFORMANCE OR IMPROVE GROUND MAINTENANCE
- 3) ACTIVE CONTROL OF THE VEHICLE IN A FEEDBACK MODE WHERE INFORMATION FROM A SENSOR AND POSSIBLY ACCOMPANYING ELECTRONICS IS USED TO CHANGE A SYSTEM PARAMETER IN REAL-TIME

POSSIBLE PATH TO TECHNOLOGY IMPLEMENTATION

- ◆ NASA CAN DEMONSTRATE THE BASIC CAPABILITIES; COMMERCIAL TECHNOLOGY IMPLEMENTATION DRIVEN BY INDUSTRY
- ◆ TYPICAL DRIVERS
 - CHANGE IN MARKET CONDITIONS
 - GOVERNMENT REGULATIONS
 - “IDEAL” APPLICATION
- ◆ NASA IS ACTIVELY DEVELOPING THE CORE TECHNOLOGY FOR FUTURE HIGH TEMPERATURE SMART SENSOR IMPLEMENTATION
 - BASIC APPROACH TARGETED TO PROVIDE A PRODUCT THAT INDUSTRY WOULD USE: COMPLETE SYSTEM, SMART, MULTIFUNCTIONAL, RELIABLE, EASY-TO-USE
 - PARALLEL PATH APPROACH TOWARDS TECHNOLOGY ACCEPTANCE
 - DEMONSTRATE INCREASING CAPABLE TECHNOLOGY IN RELEVANT CONDITIONS
 - FURTHER FUNDAMENTAL DEVELOPMENT (EVEN DOWN TO THE BASIC MATERIAL LEVEL) OF THE CORE TECHNOLOGY TOWARDS INCREASING COMPLEXITY AND CAPABILITY. KEY TO DECREASED COSTS
- ◆ MANUFACTURABILITY AND COSTS ARE DRIVING FACTORS IN IMPLEMENTATION
 - BASIC PRINCIPLES BEING SHOWN WITH SIC JFET TECHNOLOGY
 - SIGNIFICANT EFFORT TO IMPROVE SIC SEMICONDUCTOR MATERIAL QUALITY
 - WOULD POTENTIALLY ALLOW USE OF MOSFET CIRCUIT DESIGNS
 - SIGNIFICANT LEVERAGING OF EXISTING SILICON-BASED PROCESSING AND CIRCUITS

Take-Aways

ISSUES

- SMALLER, SMARTER, DISTRIBUTED SYSTEMS NEEDED FOR NEXT GENERATION ENGINES
- LIMITED HARSH ENVIRONMENT TECHNOLOGIES AVAILABLE
- COMPLETE SYSTEM PROBLEM: ELECTRONICS AS WELL AS POWER, COMMUNICATIONS, SENSORS, AND SUPPORTING TECHNOLOGIES
- HIGHER TEMPERATURE APPLICATIONS BEYOND THE CAPABILITIES OF SI OR SOI ELECTRONICS

NASA DEVELOPING CORE TECHNOLOGIES FOR FUTURE SMART SYSTEMS

- WORLD RECORD SIC ELECTRONICS DEMONSTRATED
- MOVING TOWARDS MICROSYSTEM TECHNOLOGY WITH INTEGRATED ELECTRONICS, SENSORS, POWER, AND COMMUNICATION
- TECHNOLOGY CAN BE IMPLEMENTED WITH INCREASING CONFIDENCE IN SYSTEMS, EASE OF USE, AND DEMONSTRATIONS IN THE FIELD
- COST CAN COME DOWN WITH INCREASING CIRCUIT CAPABILITY AND MATERIAL MATURITY COMBINED WITH TRANSITION FROM JFET TO MOS TECHNOLOGY.

Adaptable Core Harsh Environment Technology Being Developed and Matured to Meet the Needs of Future Intelligent Engines

DECWG

Distributed Engine Control Working Group

Approved for Public Release

65

Innovation and Entry Barriers

Derek Weber
Inprox Technology

DECWG

Distributed Engine Control Working Group

Approved for Public Release

66

Small Business Participation

INDEX SLIDE

- Market Challenges
- FADEC Architecture and Small Businesses
- DEC Architecture and Small Businesses
- Market Needs

Market Challenges

Aerospace Market Challenges for Small Businesses

- Access: availability of funding & commercialization support pathways
- Timeline 5-10 yrs. / 20yr. FADEC / Upgrades need major 'buy on'
- Who is the "real" customer in this market?
- Is there third party technology Interest? Manufacturing or Licensing...
- Risk Mitigation vs. New Technology or New Suppliers (QA/QC)

- Strong argument that DEC architecture supports Small Business Point of View (POV)
- With FADEC
 - Fixed Architecture/Centralized
 - All products/technology must fit existing envelopes and I/O
 - hardware and electronics

Resource Burden in Time & Money

Centralized Controls

FADEC Architecture & Small Businesses

- FADEC – centralized structure –version specific
- Small(er)/Shrinking Group of Suppliers & Integrators
- Static Design/Difficult to Upgrade
- Weight/Size; sub systems and wire count/cable weight
- Temperature/Thermal Management
- Component / System Obsolescence
- Non - COTS



FADEC Architecture

DECWG

Distributed Engine Control Working Group

Approved for Public Release

69

De-Centralized Controls

DEC Architecture & Small Businesses

- Modularity
 - Creates new opportunities to build niche markets
 - Expansion of current supplier base
 - New Suppliers/New Technologies
- Open Standards
- Cost & Time line Reduction
- Tapping components from commercial or automotive electronics
- Greater ability to offer new technology faster
- DEC: reduced design time, manufacture time, integration and test costs: through functional modularity and standardization --- common building blocks within engine systems and across engine platforms – helps primes, suppliers, and certification **AND Small Businesses.**

DEC Architecture Generally Supports Small Businesses POV

DECWG

Distributed Engine Control Working Group

Approved for Public Release

70

Market Needs

Aerospace Market Needs & Small Businesses

- **High Temperature Electronics**
 - (< 250C) (SOI): limited part selection – max below engine range
 - (< 500C) (SiC): very few commercial parts
 - **Affordability? Life Cycle Costs?**
- **Packaging**
- **New Technology Sensors and Actuators**
 - For smart systems/sub systems
- **Specialized Cables & Connectors**
- **Robust, Deterministic Communications**
 - Busses: from industrial, automotive or the aerospace control market
 - Standards exist, however not in engine applications
 - **Which One?**

What Materials, Markets and Standards?

Summary and Future Plans

Dennis Culley
NASA Glenn Research Center

DECWG

Distributed Engine Control Working Group

Approved for Public Release

72

Are control systems keeping pace with turbine engine system needs? (regardless of the vision)

Short answer: yes, but...

- FADEC implementation time is pacing engine development
 - Intense pressure to reduce weight and cost
- Control system upgrade costs can equal original design costs
 - Complexity and cost deters new technology insertion
 - Electronics obsolescence (determined by commercial markets) is unpredictable and uncontrollable
- Engine system advancements are increasing the physical burden on control system electronics
 - Reduced capacity for heat extraction
 - Reduced temperature margin (reliability) vs. weight of thermal control
 - Increasing need for higher density packaging to fit in shrinking envelope

What technologies are required for existing and future engine control systems?

- **Communication Network**
 - Distribution of control functions requires digital communications
 - Need for understanding the requirements for control **and** PHM
- **Power Distribution**
 - Distributed control functions require distributed power
 - Needs of control elements vary widely in current and voltage
- **High Temperature Electronics**
 - Reliable electronics require sufficient thermal margin
 - Add weight for thermal control, OR
 - Increase the operational temperature of the electronics
- **Flight Certification**
 - Cost benefit of distributed control is contingent on modular certification
 - Distributed systems are controlled by interface definitions; standard, well-defined interfaces are required

Why / How should engine control systems use emerging electronics and control technologies?

- High power control law processing remains in the realm of commercial electronics for the foreseeable future – **we must be able to use it.**
- The modularity of distributed control systems have a huge **potential** in terms of design flexibility, life cycle cost reduction, and performance enhancement.
- High temperature electronics are necessary to enable on-engine control functionality **without** additional weight for thermal control
- High temperature electronics will not be available **unless**...
 - Component/Functional needs are collaboratively defined
 - Development costs are collaboratively shared

Go – Forward Plan

A series of workshops will be planned over the next year to address the four technology challenge areas defined in this presentation

1. **Digital communication networks for turbine engine control systems**
2. **Power distribution for distributed turbine engine control systems**
3. **High temperature electronics for turbine engine control applications**
4. **Modular flight certification for distributed turbine engine control systems**

Please provide your contact information to the session chair if you are interested in participating in these workshops – US citizens only please.

Dennis E. Culley

dennis.e.culley@ nasa.gov

(216) 433-3797

DECWG

Distributed Engine Control Working Group

Approved for Public Release

76



Thank You!

DECWG

Distributed Engine Control Working Group

Approved for Public Release

77