

TIME SCALE ALGORITHM: DEFINITION OF ENSEMBLE TIME AND POSSIBLE USES OF THE KALMAN FILTER

Patrizia Tavella
Istituto Elettrotecnico Nazionale Galileo Ferraris
Strada delle Cacce, 91
10135 Torino
Italy

and

Claudine Thomas
Bureau International des Poids et Mesures
Pavillon de Breteuil
92312 Sèvres Cedex
France

Abstract

The work reported in this paper takes place in a general theoretical overview concerning the generation of an ensemble time scale. Different algorithms can be designed to match the particular needs of users and the available sets of clocks and time measurements. In all cases however, the statistical treatment of clock data requires at least:

- *the definition of an average time scale,*
- *the specification of a procedure to optimize the contribution of each clock,*
- *the implementation of a filter on each clock frequency to provide a means of prediction.*

Here, the comparative study of two time scale algorithms, devised to satisfy different but related requirements, is presented. They are ALGOS(BIPM), producing the international reference TAI at the Bureau International des Poids et Mesures, and AT1(NIST), generating the real-time time scale AT1 at the National Institute of Standards and Technology. In each case, the time scale is a weighted average of clock readings, but the weight determination and the frequency prediction are different because they are adapted to different purposes.

The possibility of using a mathematical tool, such as the Kalman filter, together with the definition of the time scale as a weighted average, is also analysed. Results obtained by simulation are presented.

INTRODUCTION

To keep time is to accumulate, without discontinuity, time scale units as close as possible to the SI second as defined in 1967 by "the duration of 9192631770 periods of the radiation corresponding to

Report Documentation Page

Form Approved
OMB No. 0704-0188

Public reporting burden for the collection of information is estimated to average 1 hour per response, including the time for reviewing instructions, searching existing data sources, gathering and maintaining the data needed, and completing and reviewing the collection of information. Send comments regarding this burden estimate or any other aspect of this collection of information, including suggestions for reducing this burden, to Washington Headquarters Services, Directorate for Information Operations and Reports, 1215 Jefferson Davis Highway, Suite 1204, Arlington VA 22202-4302. Respondents should be aware that notwithstanding any other provision of law, no person shall be subject to a penalty for failing to comply with a collection of information if it does not display a currently valid OMB control number.

1. REPORT DATE DEC 1990		2. REPORT TYPE		3. DATES COVERED 00-00-1990 to 00-00-1990	
4. TITLE AND SUBTITLE Time Scale Algorithm: Definition of Ensemble Time and Possible Uses of the Kalman Filter				5a. CONTRACT NUMBER	
				5b. GRANT NUMBER	
				5c. PROGRAM ELEMENT NUMBER	
6. AUTHOR(S)				5d. PROJECT NUMBER	
				5e. TASK NUMBER	
				5f. WORK UNIT NUMBER	
7. PERFORMING ORGANIZATION NAME(S) AND ADDRESS(ES) Istituto Elettrotecnico Nazionale Galileo Ferraris, Strada delle Cacce, 91, 10135 Torino Italy,				8. PERFORMING ORGANIZATION REPORT NUMBER	
9. SPONSORING/MONITORING AGENCY NAME(S) AND ADDRESS(ES)				10. SPONSOR/MONITOR'S ACRONYM(S)	
				11. SPONSOR/MONITOR'S REPORT NUMBER(S)	
12. DISTRIBUTION/AVAILABILITY STATEMENT Approved for public release; distribution unlimited					
13. SUPPLEMENTARY NOTES See also ADA239372. 22nd Annual Precise Time and Time Interval (PTTI) Applications and Planning Meeting, Vienna, VA, 4-6 Dec 1990					
14. ABSTRACT see report					
15. SUBJECT TERMS					
16. SECURITY CLASSIFICATION OF:			17. LIMITATION OF ABSTRACT Same as Report (SAR)	18. NUMBER OF PAGES 13	19a. NAME OF RESPONSIBLE PERSON
a. REPORT unclassified	b. ABSTRACT unclassified	c. THIS PAGE unclassified			

the transition between the two hyperfine levels of the ground state of the caesium atom"^[1].

Time laboratories have at their disposal commercial caesium clocks. But physical devices can fail, so these laboratories are inevitably led to keep not one, but several clocks which are together treated as an ensemble. Clock readings are then combined through an algorithm designed to raise the stability, accuracy and reliability of the time scale above the level of performance of any individual clock in the ensemble.

In the design of a time scale algorithm there is no general solution. Rather the fundamental ingredients should be artfully mixed to match the available time measurements and the needs of the user. Some of these ingredients are the definition of an average time scale, the specification of a weighting procedure, the determination of a means to predict clock frequencies and the implementation of a filter on measurement noise.

In this paper the key point of the definition of the time scale is highlighted for different algorithms. In a first section, we propose the comparative study of two time scale algorithms: ALGOS(BIPM)^[2], producing the international reference, TAI, at the Bureau International des Poids et Mesures, and AT1(NIST)^[3], generating the real-time time scale, AT1, at the National Institute of Standards and Technology. Though the weight determination and the frequency prediction are different, because they are adapted to different purposes, these two algorithms rely on the same definition of the time scale.

In a second section we emphasize the possible use of the Kalman filter for a time scale. This mathematical tool is first briefly presented and then shown as being valuable help in the efficient processing of clock data. Here we show with three examples of algorithms based on Kalman filtering^[4, 5, 6] that this technique can be unpowerful for the elaboration of a time scale if an equation of definition is not set. Finally, our own view of how to take advantage of the Kalman filter is given together with results obtained from simulated clock data.

Note: In what follows symbols are defined as:

- t : date of the time scale update,
- H_i : clock identification,
- $h_i(t)$: reading of clock H_i at date t
(this quantity is not directly accessible by experiment),
- p_i : weight assigned to clock H_i ,
- $x_i(t) = TA - h_i(t)$: clock $H - i$ time offset from the time scale
TA under computation
(this quantity gives user access to the time scale),
- N : clocks number,
- $x_{ij}(t) = h_j(t) - h_i(t) = x_i(t) - x_j(t)$: measurement between clock H_j and clock H_i at date t ,
- τ : time interval between two measurement cycles.

1. COMPARATIVE STUDY OF ALGOS(BIPM) AND AT1(NIST)

The detailed analysis of the comparison of the two algorithms, ALGOS(BIPM) and AT1(NIST), has been published elsewhere^[7]. Here we give only the main features of that study in order to focus on the definition of the time scale in these two cases.

1-1 ALGOS(BIPM)

ALGOS(BIPM) produces the international reference, TAI (temps atomique international), at the Bureau International des Poids et Mesures (Sèvres, France). The requirement here is for extreme reliability and long-term stability. To this end, TAI relies on a large number of clocks of different types, located in different parts of the world and connected in a network allowing the precise exchange of time data. Although measurements are performed at intervals of $\tau=10$ days, the definitive update of TAI is obtained from an iterative and post-processed procedure which treats, as a whole, two-month blocks of data and so ensures long-term stability^[2, 7]. One important consequence is that TAI is a deferred-time time scale.

The first step in the establishment of TAI is the computation of a free atomic time scale, EAL (échelle atomique libre), obtained as a weighted average of clock readings. TAI is then derived from EAL with a frequency steering in order to ensure accuracy. For each date t of the two-month interval of computation $[t_0, t_0 + 60 \text{ days}]$, EAL is defined as:

$$EAL(t) = \frac{\sum_{i=1}^N p_i [h_i(t) + h'_i(t)]}{\sum_{i=1}^N p_i}. \quad (1)$$

In this equation, p_i is the weight assigned to clock H_i , and $h'_i(t)$ is a time correction applied at date t to ensure time and frequency continuity of the scale when the weights of clocks or the total number of clocks is changed^[8]:

$$h'_i(t) = x_i(t_0) + B_{ip} \cdot (t - t_0), \quad (2)$$

here $B_{ip}(t)$ is the frequency of clock H_i , relative to EAL, predicted for the period t_0, t .

From equation (1) and the above notations, we get the system of equations:

$$\begin{cases} \sum_{i=1}^N p_i x_i(t) = \sum_{i=1}^N p_i h'_i(t) \\ x_{ij}(t) = x_i(t) - x_j(t) \end{cases}. \quad (3)$$

The time measurements are chosen to be non-redundant so that the system (3) is deterministic with N equations and N unknowns and so is exactly solvable at each date t . The results are the quantities $x_i(t_0 + n\tau)$ with $n = 0, 1, 2, 3, 4, 5$ and 6 for each clock H_i . Clock H_i frequency $B_i(t_0 + 60 \text{ days})$ for the two-month interval under computation is obtained as the least squares slope of the quantities $x_i(t_0 + n\tau)$.

The detailed and complete description of the weighting procedure is described elsewhere^[7]. The general principle is that the weight assigned to clock H_i is set to be inversely proportional to the frequency variance of the clock over six two-month samples. This ensures the long-term stability of EAL and allows deweighting for seasonal fluctuation. An upper limit of weight and a system for the detection of abnormal behaviour are also in use in ALGOS(BIPM).

The frequency prediction is a one step linear prediction^[7], the supposition being that each clock most likely behaves in the present two-month interval as it did in the previous one. This is the optimal estimate for random walk frequency modulation, which is the predominant clock noise for two-month averaging time.

1-2. AT1(NIST)

The AT1 time scale, developed at the National Institute of Standards and Technology (Boulder, Co, USA) is used for scientific studies. The basic requirement is to provide definitive access to the time scale in near real time, with no post-processing or reprocessing. It is an average time scale derived from measurements taken from about 10 commercial clocks located on the site. The AT1(NIST) algorithm estimates time, adaptive weight and frequency^[3] for each contributing clock at each measurement cycle, at present $\tau = 2$ hours.

The equations for computing the time scale at date t are based on predicted values \hat{x}_i and \hat{y}_i for the time and frequency of each clock. The predicted time difference $\hat{x}_i(t)$ of clock H_i relative to AT1, for the date t , involves the time offset $x_i(t - \tau)$ obtained from the previous computation and the frequency $\hat{y}_i(t - \tau)$ estimated at date $t - \tau$ and predicted for the next τ period. This is written as:

$$\hat{x}_i(t) = x_i(t - \tau) + \hat{y}_i(t - \tau) \cdot \tau. \quad (4)$$

This equation is completely similar to (2) in the description of ALGOS(BIPM) if $t - t_0$ is set equal to τ .

The definition of the time scale itself is written as:

$$x_i(t) = \frac{\sum_{j=1}^N P_j [\hat{x}_j(t) - x_{ij}(t)]}{\sum_{j=1}^N P_j}. \quad (5)$$

where $x_{ij}(t)$ is the non-redundant set of time measurements.

A trivial transformation of (5) leads to:

$$x_i(t) = \frac{\sum_{j=1}^N P_j [\hat{x}_j(t) - x_j(t)] + x_i(t)}{\sum_{j=1}^N P_j}, \quad (6)$$

so that we get the system of equations:

$$\begin{cases} \sum_{j=1}^N P_j x_j(t) = \sum_{j=1}^N P_j \hat{x}_j(t) \\ x_{ij}(t) = x_i(t) - x_j(t) \end{cases} \quad (7)$$

This is a system of N equations with N unknowns, equivalent to system (3) for ALGOS(BIPM).

The analogy in the definition of EAL and AT1 time scales is then complete.

Weights p_i appearing in (5), designed to ensure stability, have been determined in the previous computation at date $t - \tau$ with an exponential filter over the time deviations between predicted and estimated time differences of the last N_τ periods^[3]. The time constant N_τ is usually set at 20 to 30 days. These time deviations are also corrected for the bias introduced by the correlation between the clock itself and the average time scale^[3]. A detector of abnormal behaviour and an upper limit of weight^[7] exist also in AT1(NIST).

The predicted frequency $\hat{y}_i(t)$ comes from an exponential weighted average of past and present mean frequencies. The time constant of this exponential filter being characteristic of the statistical behaviour of each contributing clock.

Conclusions

The ALGOS(BIPM) and AT1(NIST) algorithms rely on the same basic definition of the time scale, generated as a weighted average of clock readings. They also present other common features: measurements of time differences are treated as having negligible uncertainties and clocks are supposed uncorrelated among them.

The appropriate way to determine clock weights and to predict clock frequencies depends essentially on the available measurements (number of clocks, measurement sampling) and on the properties required for the resulting time scale (real-time updating or deferred-time post-processing).

2. TIME SCALES BASED ON KALMAN FILTERING

2-1 KALMAN FILTERING OUTLINE

The Kalman filter, which is used in many signal processing applications, is a tool well-adapted for stochastic estimation and prediction. It is a recursive and linear filter, optimal in the sense of least squares estimation^[9, 10].

Its property of recursivity makes of this filter an interesting tool for help in the elaboration of a time scale: it allows a definitive treatment at each measurement cycle and provides a means of prediction for the next step. The system under estimation, in the case of a time scale, includes clock time offsets and clock frequencies. The evolution with time of these quantities can easily be represented by a linear model, linearity being a necessary condition for application of the Kalman filter theory. In addition measurement noise and correlation among clocks can naturally be inserted in the model whereas it is not the case for the two previous algorithms.

Here is a brief description of how Kalman filtering operates. The intention is to avoid equations which can be found elsewhere^[10] but rather present basic ideas in the schematic way of Fig. 1 and 2.

Consider a dynamical system which evolves linearly with time. At date t its state is represented by a vector $X(t)$. We wish to estimate this vector using measurements, obtained with a τ measurement cycle, for times preceding date t . Suppose that the system state was estimated at date $t - \tau$ by the vector $X(t - \tau/t - \tau)$, a quantity which must be read as **estimate of X at date $t - \tau$ knowing**

all the measurements up to date $t - \tau$. This estimate has an error given by a covariance matrix $\Gamma(t - \tau/t - \tau)$ and represented on Fig. 1.

According to the model of evolution and to the noise of the model given by the covariance matrix $Q(t)$, the transition step of the Kalman filter (Fig. 1) allows us to estimate the predicted state of the system at date t , knowing all the measurements up to date $t - \tau$: the vector $X(t/t - \tau)$. The error on the estimation of this vector is given by the matrix $\Gamma(t/t - \tau)$, which includes the matrix $Q(t)$. This error is larger than the error at date $t - \tau$, mainly because the model is not perfect (see Fig. 1).

We now represent a new measure by a vector $Z(t)$ which is affected by an error given by the matrix $R(t)$ and represented on Fig. 1. From the predicted state at date t and this new information, the Kalman filter computes a new estimate of the state of the system according to an "update adjustment" described in Fig. 2. This new estimate is represented by the vector $X(t/t)$ affected by a covariance matrix $\Gamma(t/t)$, the trace of which has been minimized.

The update adjustment of Fig. 2 builds the new estimate from the old one and from the innovation weighted by the Kalman gain. The innovation represents the new information contained in the last measurement: it is simply the difference between the real measure and a predicted measure, expected from the predicted state at t knowing $t - \tau$. The Kalman gain $K(t)$ is given by a complex expression involving all the errors which affect the system, mainly Γ , Q and R ^[10]. Qualitatively, if the measurement $Z(t)$ is very good, that is, affected by a very small error, the Kalman gain at date t will be large so that the new estimate of the system state will largely rely upon the new observation. On the contrary, if the measurement is very bad, the adjustment process of the Kalman filter will tend to ignore it.

At last one more detail: the noises which are involved in the Kalman recurrence must be white noises.

2-2 EXAMPLES OF APPLICATION OF THE KALMAN FILTERING TO THE COMPUTATION OF A TIME SCALE

The first attempt to apply the Kalman filter to the problem of time scales was performed by Tryon and Jones in 1982^[4]. Their system is an ensemble of N clocks. The system state $X(t)$ has $2N$ components: the N clock time offsets $h_i(t)$ and the N clock frequencies $y_i(t)$ relative to an ideal time scale. The model integrates each clock time and frequency affected by white frequency noise and random walk frequency modulation. The measurement vector $Z(t)$ is composed of the $(N-1)$ time differences, measured between each clock and the reference clock. The measurement noise is supposed to be negligible. The result of the Kalman recursivity is an estimate of how each clock departs from an ideal time scale, but it is found that the error of this estimate always increases with time. This non-convergence of the covariance matrix Γ arises from the lack of observability of the system: N quantities $h_i(t)$ being estimated from only $(N-1)$ measurements. In this case the Kalman filter is an efficient tool for filtering the data noise but, isolated, it does not have the power to build an average time scale.

Another example is the approach developed by Stein^[5], where a Kalman filter is applied on the time measurements $x_{ij}(t)$ themselves, to smooth out the white phase noise. These filtered measurements are then used to predict the time offset of a given clock, relative to the ensemble time, in $(N-1)$ different ways, each way passing through another clock of the ensemble. The definitive estimate of this time offset comes from a weighted average of these different predictions. The weighted average is defined by (3) or (5) and computed with a static and robust Kalman filter.

The Kalman filter is also used for time scales as a complement to the AT1(NIST) algorithm for frequency step detection. This work, proposed by Weiss and Weissert^[6], utilizes the results $x_i(t)$ of AT1 in order to realize pseudo-measurements of the frequency of each clock relative to the ensemble time. The white noise of these pseudo-measurements is filtered and so gives access to the random walk component of each frequency and to the variance of this estimation. They are then tested for possible step.

2.3 A NEW PROPOSAL FOR USING THE KALMAN FILTER IN TIME SCALE GENERATION

Here we propose a new approach for using the Kalman filter in time scale generation and present results obtained with simulated clock data.

We start with the same hypothesis and defining equations as were used for ALGOS(BIPM) and AT1(NIST).

Suppose an ensemble of N clocks, the frequencies of which are uncorrelated. One clock is chosen as the reference. Each day $N-1$ time measurements are performed ($\tau = 1$ day). Suppose also that the white phase noise of the measurements is smoothed out before the main computation of the time scale so that it can be treated as negligible. The ensemble time scale is defined by (3) or (5) as:

$$x_j(t + \tau) = \frac{\sum_{i=1}^N P_i [\hat{x}_i(t + \tau) - x_{ij}(t + \tau)]}{\sum_{i=1}^N P_i} \quad (8)$$

with: $\hat{x}_i(t + \tau) = x_i(t) + \hat{y}_i(t) \cdot \tau$, similar to (4),

where $\hat{y}_i(t)$ is the predicted frequency for the interval $[t, t + \tau]$.

The weight p_i and the predicted frequency $\hat{y}_i(t)$, relative to the time scale, of each clock are chosen outside the main computation to ensure the best long-term stability.

Now we wish to improve the short-term stability of the scale. For this purpose we use $N-1$ Kalman filterings, each of them operating on just two clocks, the reference clock H_j and another one chosen among the ensemble H_i . This decoupling supposes that the $N-1$ pairs of clocks are uncorrelated, which is theoretically not true, as the same reference clock is involved in each pair. However, one can choose the least noisy clock as reference and suppose the coupling to be small. Anyway the correlation of the $N-1$ pairs can be easily inserted in a Kalman filter operating on all the pairs together.

For each Kalman filter, the state of the system is composed of a single quantity, the frequency $y_{ij}(t)$ at date t of clock H_i relative to the reference clock. The model of evolution of the system is written as:

$$y_{ij}(t + \tau) = y_{ij}(t) + \alpha_{ij} , \quad (9)$$

where α_{ij} is white noise driving the random walk frequency modulation of the clock. The Q matrix is reduced here to the variance of the white noise α_{ij} .

Frequency measurements are deduced from time measurements with the equation:

$$z_{ij}(t + \tau) = \frac{x_{ij}(t + \tau) - x_{ij}(t)}{\tau} = y_{ij}(t + \tau) + \beta_{ij} \quad (10)$$

and are affected with white frequency modulation β_{ij} , with variance R .

The application of the Kalman filter leads to an estimation of the random walk component of the frequency $y_{ij}(t + \tau)$ of clock H_i relative to clock H_j while smoothing out the white frequency modulation.

Now, the filtered estimate $y'_{ij}(t + \tau)$ of the frequency $y_{ij}(t + \tau)$ can be introduced in the equation of definition of the time scale as:

$$x_j(t + \tau) = \frac{\sum_{i=1}^N P_i [x_i(t) + \hat{y}_i(t) \cdot \tau] - \sum_{i=1}^N P_i [x_{ij}(t) + y'_{ij}(t + \tau) \cdot \tau]}{\sum_{i=1}^N P_i} \quad (11)$$

or

$$x_j(t + \tau) = \frac{\sum_{i=1}^N P_i [x_i(t) - x_{ij}(t)]}{\sum_{i=1}^N P_i} + \frac{\sum_{i=1}^N [\hat{y}_i(t) - y'_{ij}(t + \tau) \cdot \tau]}{\sum_{i=1}^N P_i} \quad (12)$$

The first term of (12) is $x_j(t)$, the time offset of the reference clock H_j with respect to the average time scale. The second term is the weighted average of estimations of the frequency of clock H_j relative to the time scale, obtained through clock H_i and the filtered frequency of clock H_i relative to clock H_j ; it is then the frequency of the reference clock H_j relative to the average time scale at date $t + \tau$.

Our proposal consists in filtering the white frequency modulation to estimate the random walk component of the frequency of a clock relative to another clock and then introducing this filtered frequency in the definition of the average time scale. This approach is thus opposite to that developed by Weiss and Weissert^[6].

This new procedure has been investigated with simulated clock data: 6 clocks were simulated with different levels of white frequency modulation and random walk of frequency for a 300-day period. One clock has better short-term and long-term stability than the others: this is chosen as the reference clock. The frequency stability for the 5 pairs of clocks is given on Fig. 3. After filtering of the white frequency modulation, the short-term frequency stability for each pair of clocks is largely improved, as shown on Fig. 4. The efficiency of the filtering is presented on Fig. 5 for a given pair of clocks: the white frequency modulation is smoothed out, leading to the extraction of the random walk component of the frequency of one of the clocks relative to the other.

For the computation of the time scale, the weight p_i of clock H_i is chosen to be the reciprocal of its Allan variance computed over 30 days. The predicted frequency of clock H_i relative to the time scale, \hat{y}_i , is the average of the previous 30-day frequency data. This averaging time is chosen to improve the long-term stability of the average time scale.

The frequency stability of the resulting time scale, computed either with raw data or after implementation of the Kalman filtering procedure, is presented on Fig. 6: the average time scale obtained with filtered data has a lower level of white frequency modulation and so is more stable using averaging time in the range 1–30 days. After a 30-day averaging time, the random walk frequency noise is predominant and the two time scales have the same behavior.

CONCLUSIONS

The first step of the construction of a time scale is the definition of the ensemble time. For most time scale algorithms used in timing centers, the ensemble time is a weighted average of clock readings. The determination of the contribution of each clock and the mode of prediction of its frequency relative to the time scale are chosen in order to match special user needs and available time measurements.

The Kalman filter is a tool well adapted to time scale generation once the definition of the ensemble time has been given. It helps to smooth out the white phase noise of the time measurements. Its use for filtering the white frequency modulation of the clocks themselves is a new approach. In this case the time scale is built with the random walk component of the frequencies of the clocks relative to a single clock chosen as reference. The short-term stability of the resulting time scale is then significantly improved.

REFERENCES

1. Resolution 1 of the 13th Conférence Générale des Poids et Mesures, 1967–1968.
2. B. Guinot and C. Thomas, *Establishment of International Atomic Time*, BIPM Annual Report 1988, Part D, pp. D1–D22.
3. F. B. Varnum, D. R. Brown, D. W. Allan and T. K. Pepler, *Comparison of time scales generated with the NBS ensembling algorithm*, Proc. of the 19th Annual Precise Time and Time Interval (PTTI) Applications and Planning meeting, 1987, pp.13–23.
4. R. H. Jones and P. V. Tryon, *Continuous time series models for unequally spaced data applied to modeling atomic clocks*, Siam J. Sci. Stat. Comput., vol.8, nx1, 1987, pp. 71–81.
5. S. R. Stein, A. Gifford and L. A. Breakiron, *Report on the time scale algorithm test bed at USNO*, Proc. of the 21st Annual Precise Time and Time Interval (PTTI) Applications and Planning Meeting, 1989, pp. 269–288.
6. M. A. Weiss and T. Weissert, *A new time scale algorithm: AT1 plus frequency variance*, Proc. of the 21th Annual Precise Time and Time Interval (PTTI) Applications and Planning meeting, 1989, pp. 343–358.
7. P. Tavella and C. Thomas, *Comparative study of time scale algorithms*, submitted to Metrologia, April 1990.
8. B. Guinot, *Some properties of algorithms for atomic time scales*, Metrologia, 24 1987, pp. 195–198.
9. R. E. Kalman and R. Bucy, *New results in linear filtering and prediction theory*, Transactions of the ASME, Journal of Basic Engineering, 83D, 1961, pp. 95–108.
10. S. A. Tretter, *Introduction to discrete-time signal processing*, Ed. John Wiley & sons, 1976, Chapters 13 & 14.

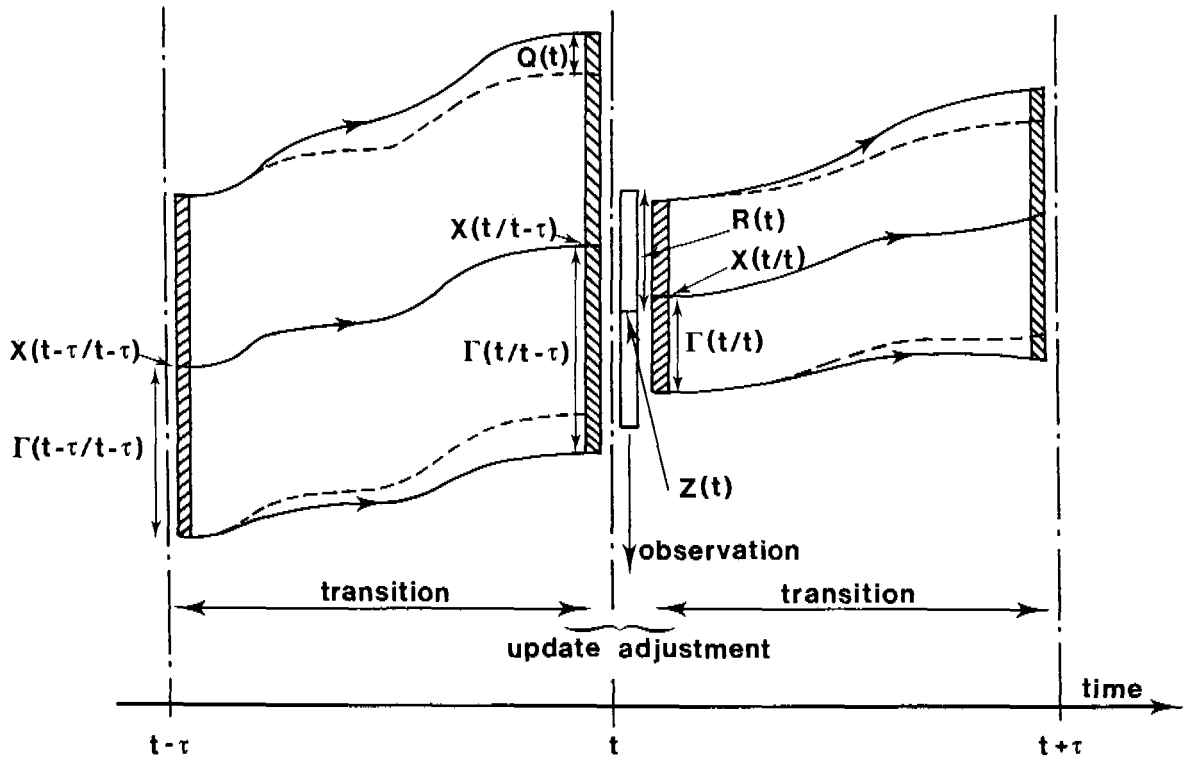

FIGURE 1: Recursive procedure for the Kalman filter.

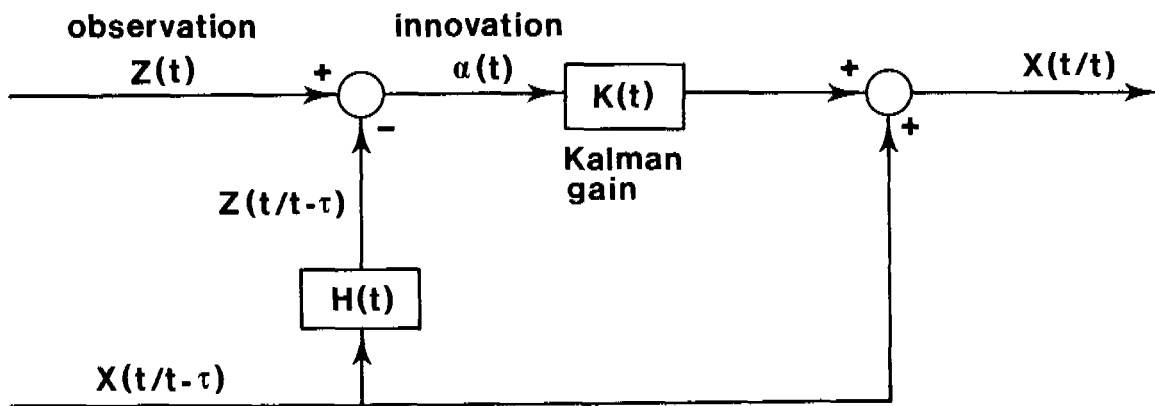

FIGURE 2: Schematic description of the adjustment process for the Kalman filter, leading to the updated estimation of the state of the system (The H matrix, not specified in the text, is the 'observation matrix' which links the vector of the system state, X , to the vector of measurement, Z . If all the quantities under estimation are observable, H is the matrix Identity).

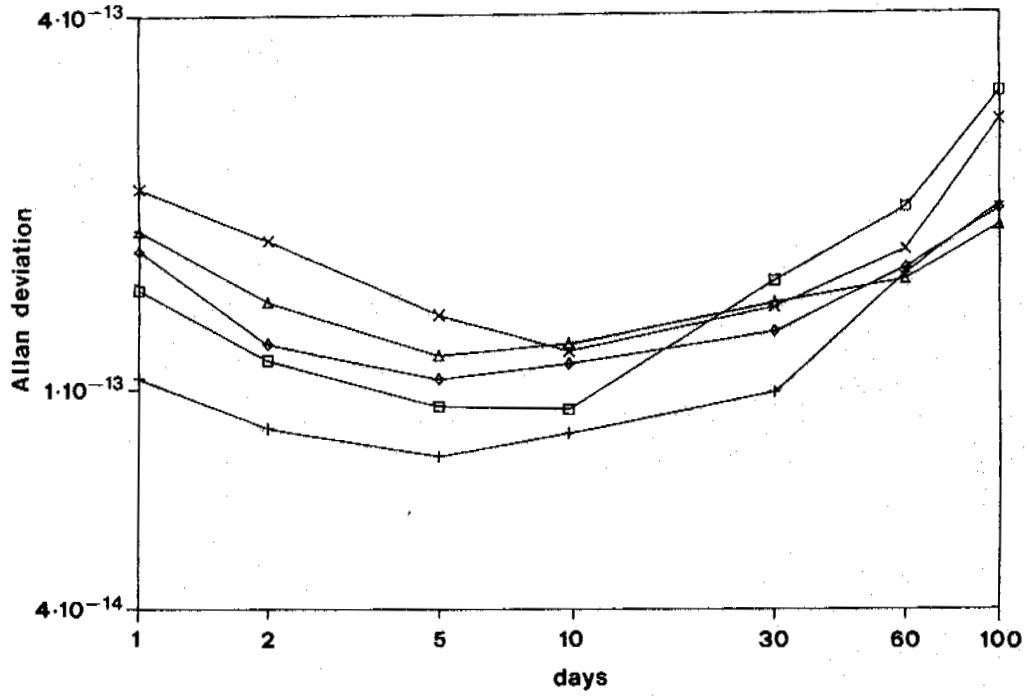

FIGURE 3: Allan deviation for five pairs of clocks. The clocks are simulated with different levels of white frequency modulation and random walk frequency modulation.

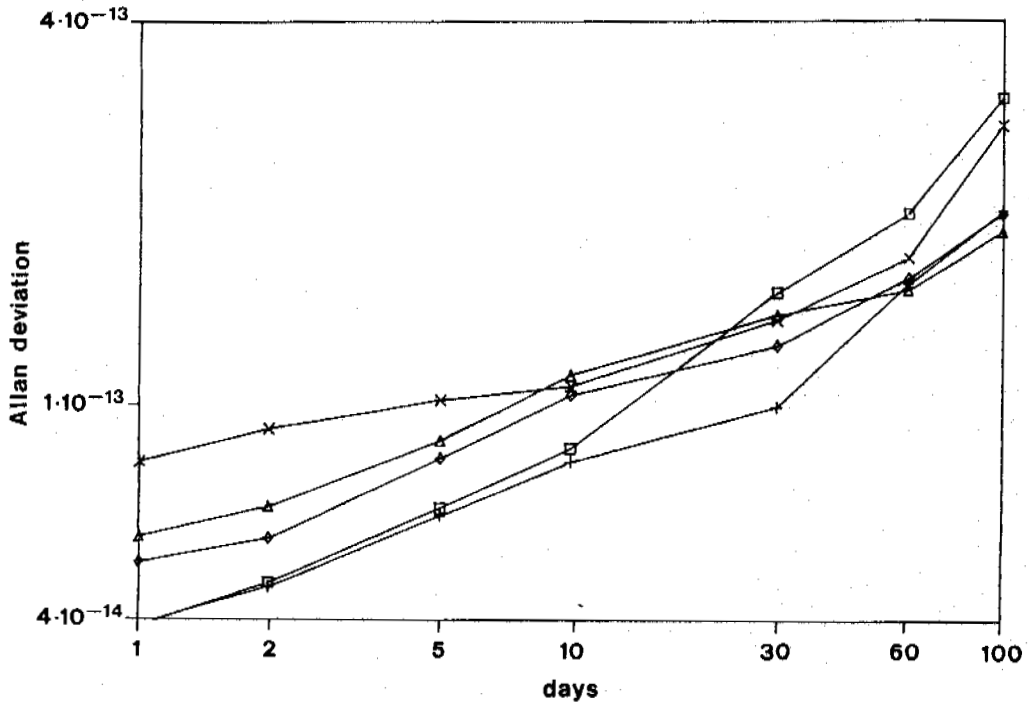

FIGURE 4: Allan deviation of the same pairs of clocks as in Fig. 3, after application of a Kalman filter for smoothing out the white frequency modulation.

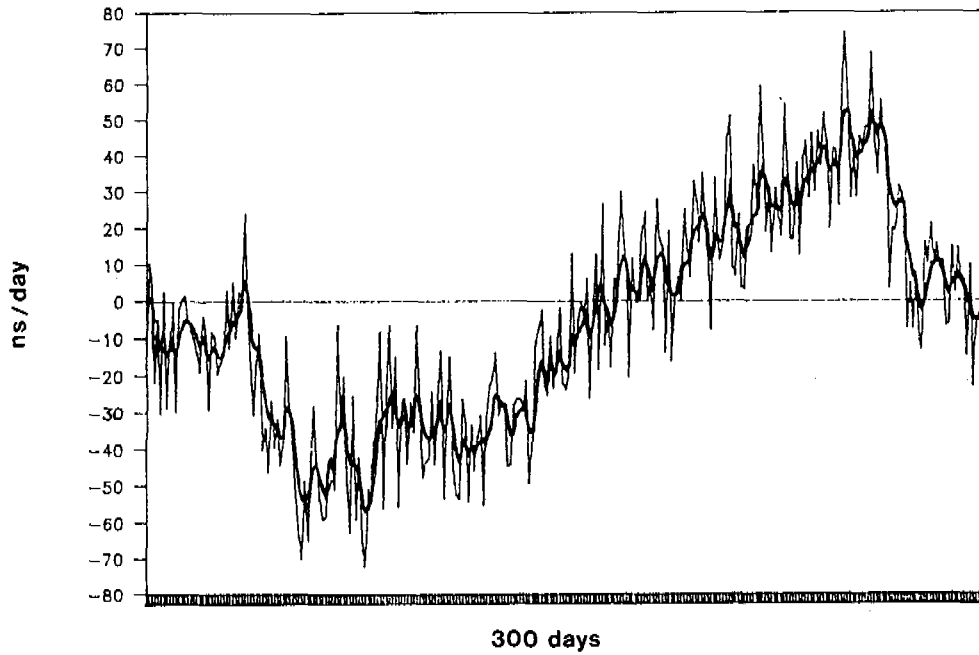

FIGURE 5: Example of Kalman estimation of the random walk component of the frequency:

— measured frequency
 — estimated frequency

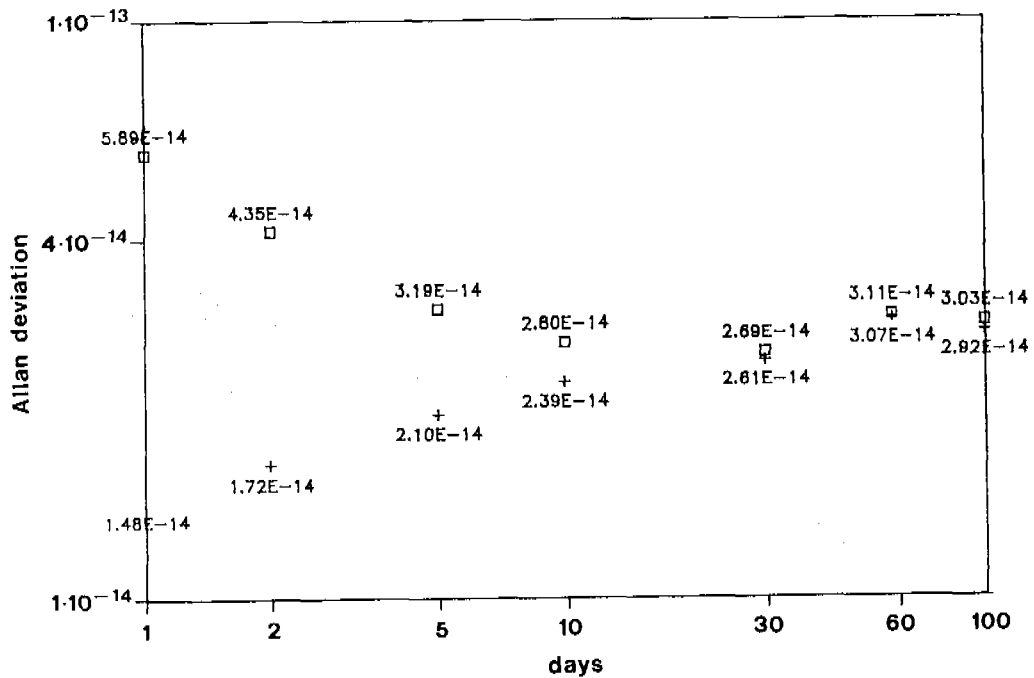

FIGURE 6: Stability of the average time scales obtained with simulated clock data:

□ raw clock data,
 + filtered clock data.

QUESTIONS AND ANSWERS

Unidentified Questioner: Was your data tested for periodicity, such as for the apparent ten day period in the graph? Was any Chi square test performed? Was the noise tested for whiteness and Gaussian behavior?

Ms. Tavella: Each type of noise was obtained from random white noise.