

Impact of emerging WDM technology on high-performance system interconnects

Exploiting the wavelength dimension to provide

More computation in smaller spaces

Want “*More brains, less brawn*”

Logic, memory, and
memory access

weight, size, power,
copper, batteries, ...

Tony Levi, University of Southern California
alevi@usc.edu



Clay Hudgins, Harris Corporation — Communications Systems Division
chudgins@harris.com



Dave Dolfi, Agilent Technologies
dave_dolfi@agilent.com



Report Documentation Page

Form Approved
OMB No. 0704-0188

Public reporting burden for the collection of information is estimated to average 1 hour per response, including the time for reviewing instructions, searching existing data sources, gathering and maintaining the data needed, and completing and reviewing the collection of information. Send comments regarding this burden estimate or any other aspect of this collection of information, including suggestions for reducing this burden, to Washington Headquarters Services, Directorate for Information Operations and Reports, 1215 Jefferson Davis Highway, Suite 1204, Arlington VA 22202-4302. Respondents should be aware that notwithstanding any other provision of law, no person shall be subject to a penalty for failing to comply with a collection of information if it does not display a currently valid OMB control number.

1. REPORT DATE 18 APR 2000		2. REPORT TYPE N/A		3. DATES COVERED -	
4. TITLE AND SUBTITLE Impact of Emerging WDM Technology in High-Performance System Interconnects				5a. CONTRACT NUMBER	
				5b. GRANT NUMBER	
				5c. PROGRAM ELEMENT NUMBER	
6. AUTHOR(S)				5d. PROJECT NUMBER	
				5e. TASK NUMBER	
				5f. WORK UNIT NUMBER	
7. PERFORMING ORGANIZATION NAME(S) AND ADDRESS(ES) Agilent Technologies				8. PERFORMING ORGANIZATION REPORT NUMBER	
9. SPONSORING/MONITORING AGENCY NAME(S) AND ADDRESS(ES)				10. SPONSOR/MONITOR'S ACRONYM(S)	
				11. SPONSOR/MONITOR'S REPORT NUMBER(S)	
12. DISTRIBUTION/AVAILABILITY STATEMENT Approved for public release, distribution unlimited					
13. SUPPLEMENTARY NOTES DARPA/MTO, WDM for Military Platforms Workshop held in McLean, VA on April 18-19, 2000, The original document contains color images.					
14. ABSTRACT					
15. SUBJECT TERMS					
16. SECURITY CLASSIFICATION OF:			17. LIMITATION OF ABSTRACT	18. NUMBER OF PAGES	19a. NAME OF RESPONSIBLE PERSON
a. REPORT unclassified	b. ABSTRACT unclassified	c. THIS PAGE unclassified			

- **What does WDM provide?**
 - ◆ Another dimension of freedom in system design
- **Where should we look for big payoffs?**
 - ◆ All networked systems
 - ◆ Mobile systems
 - ◆ Micro systems
- **What are the ultimate goals?**
 - ◆ Provide capability to leapfrog incremental system improvements
 - ◆ Optimal information distribution
 - ◆ Real-time collaborative decision making
 - ◆ Military need to push algorithms and appropriate decision making out of the back-office and into the field

- **What drives network traffic?**
 - ◆ Processor advances

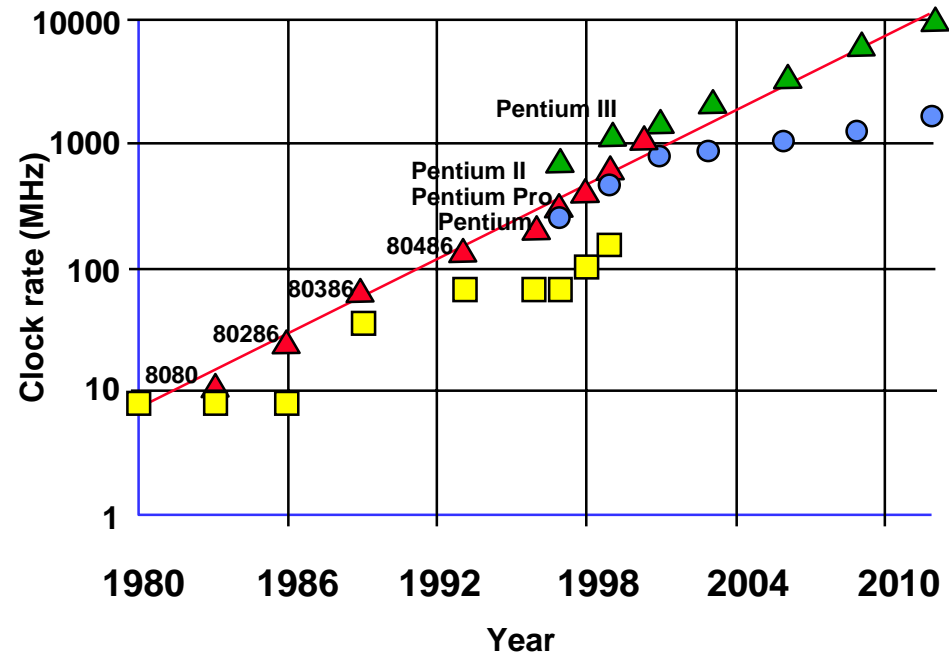

- ▲ Intel processor
- Intel bus
- ▲ SIA processor
- SIA bus

Key questions and preliminary answers

- **What is needed to achieve goals?**
 - ◆ More computations per unit {size • weight • power}
 - ◆ More *“brains per unit brawn”*
- **What’s holding us back today**
 - ◆ *Not enough chip-level I/O to keep transistors busy*
 - ◆ PCB technology stressed by 1000+ chip I/O
 - ✧ stacked micro-vias
 - ◆ Lack of commercial investment
 - ✧ WDM technology focused on long-haul telecommunications systems
 - ✧ Data-communications investment focused on squeezing “just a little more” out of copper



Example:
USC PONI-ROPE PCB area < 50%
ICs, surface mount packages,
12-metal layers, Gb/s per signal line,
de-skewed signal lines to +/- 10 ps,
5 mil lines, 7 mil spaces

Electrical test fixture for USC LA chip

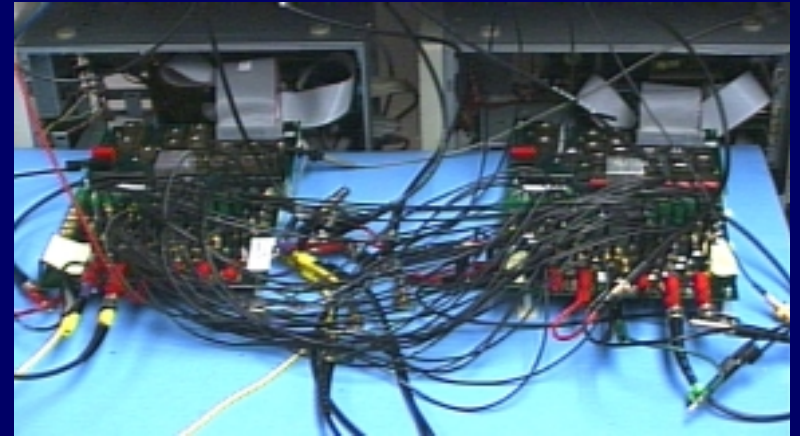

Agilent POLO-2 module and USC LA chip

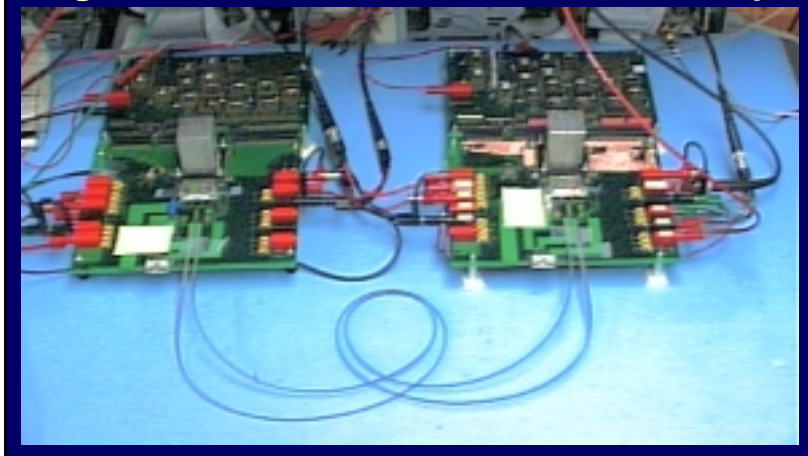

Key questions

and preliminary answers

■ Where is the commercial technology going in three years?

- ◆ Low-voltage differential signaling at Gb/s rates
- ◆ Ubiquitous 1000+ chip I/O packaging
- ◆ Exotic PCB technology
- ◆ *Preparing for incremental improvements*

■ What is DARPA's opportunity over three to five years?

- ◆ Focus on efficient inter- and intra-PCB interconnect
- ◆ Nano-photonic components for wavelength-routed 10 Gb/s per line system interconnect
- ◆ *Leapfrog incremental improvements and provide components for new system optimization*

Future heterogeneous integration of photonic Media Access Control

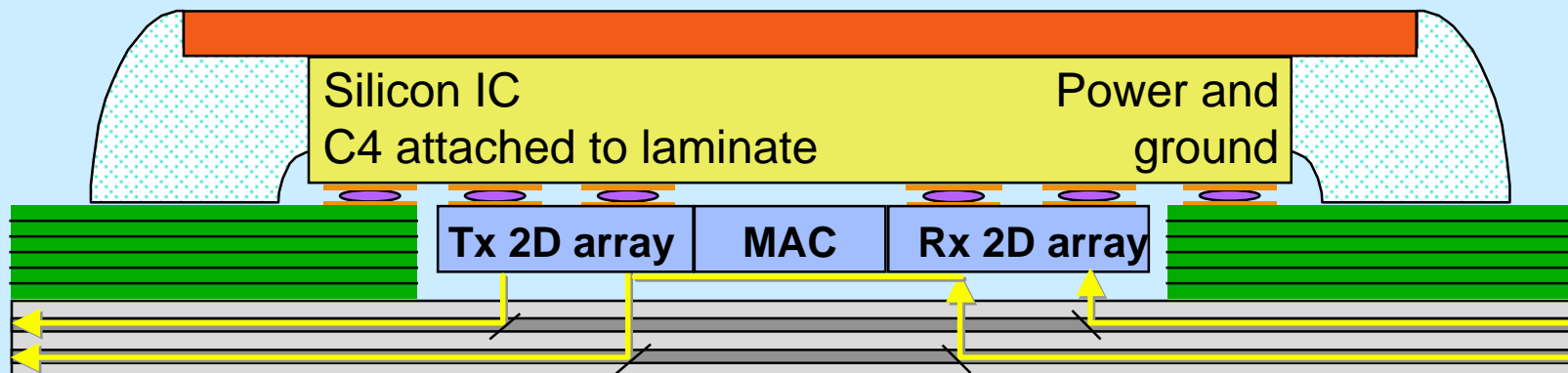

■ Concept

- ◆ Topologically simple chip-to-chip optical interconnects
- ◆ WDM to compete with Cu for spatial density
- ◆ Complex logical topologies created by switching in silicon

■ WDM provides

- ◆ Improved data-bandwidth density compared to TDM or spatial multiplexing
- ◆ Lower-cost connector compared to parallel fiber-optic solution
- ◆ Future use of integrated nano-photonic components for all-optical functions

Multi-processor node 10x10 cm²

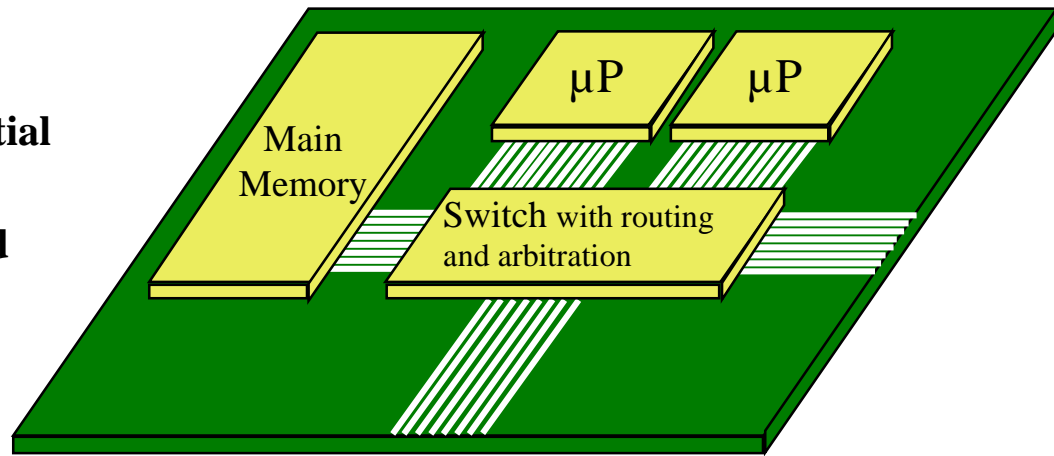

■ Ideal network router

- ◆ Non-blocking connectivity
- ◆ Speed-of-light latency
- ◆ Infinite-bandwidth

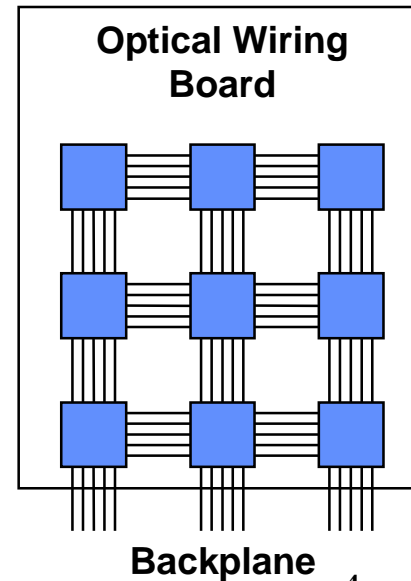

■ Deadlock kills switched systems

- ◆ Switched systems implement algorithms that *avoid* deadlock because of its impact on performance
- ◆ Conventional solution prevents packets from entering the network
 - ◇ Packet discard
 - ◇ Flow control with back-pressure feedback using dedicated lines to stop transmission until receiver is ready
 - ◇ Choke packet warning returned to source on switch overload. Source reduces its traffic by a percentage amount

■ WDM can provide an efficient recovery mechanism

- ◆ Overlay a wavelength-configurable interconnect onto a topologically simple system interconnect
- ◆ Route incoming data to empty buffers in congestion free-part of the network

■ Simple physical topological

- ◆ Logically discrete channels
- ◆ Efficient distribution of global system parameters

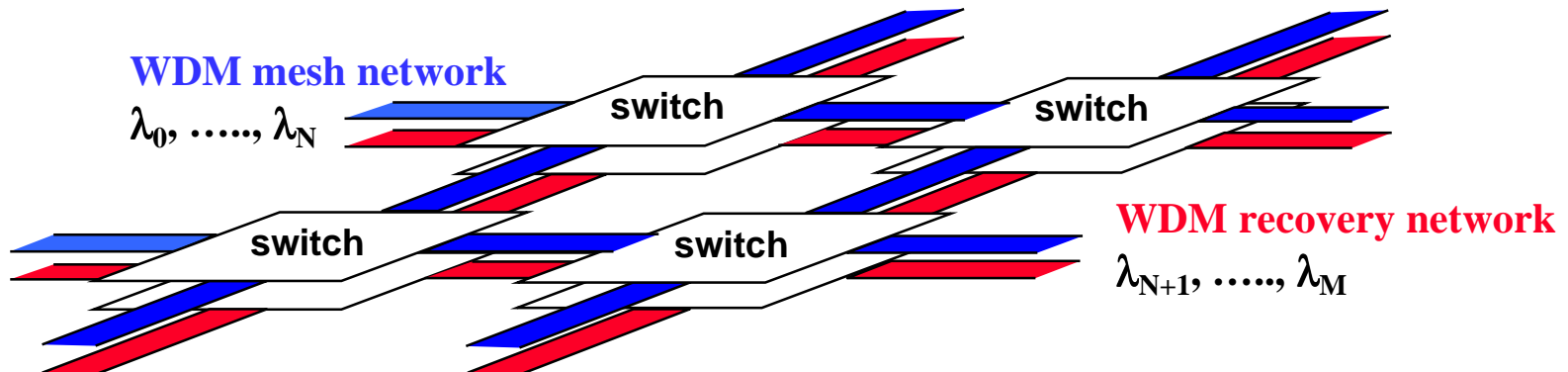

- **Time Division and Space Division Multiplexing have been exploited**
- **Wavelength Division Multiplexing**
 - ◆ Provides additional dimension for system design
 - ◆ Important new tool for achieving more “*brains per unit brawn*” in aerospace and mobile systems
 - ◆ Successfully implemented in long-haul telecommunication systems
 - ◆ Migration to small systems enabled by
 - ✧ Nano-photonics
 - ✧ Innovative packaging and integration
- **The promise of WDM optics**
 - ◆ “Free, infinite-bandwidth density, anywhere, anytime !”
- **DARPA involvement provides focus on**
 - ◆ Integrated CMOS-based opto-electronics *inside* systems
 - ◆ WDM micro-photonic functionality *inside* systems