

Methodology for Composite Durability Assessment



Akira Kuraishi
Stanford University

Jonathan H. Gosse
Jeffrey A. Wollschlager
John L. Townsley
The Boeing Company

Report Documentation Page

Form Approved
OMB No. 0704-0188

Public reporting burden for the collection of information is estimated to average 1 hour per response, including the time for reviewing instructions, searching existing data sources, gathering and maintaining the data needed, and completing and reviewing the collection of information. Send comments regarding this burden estimate or any other aspect of this collection of information, including suggestions for reducing this burden, to Washington Headquarters Services, Directorate for Information Operations and Reports, 1215 Jefferson Davis Highway, Suite 1204, Arlington VA 22202-4302. Respondents should be aware that notwithstanding any other provision of law, no person shall be subject to a penalty for failing to comply with a collection of information if it does not display a currently valid OMB control number.

1. REPORT DATE NOV 2002	2. REPORT TYPE N/A	3. DATES COVERED -			
4. TITLE AND SUBTITLE Methodology for Composite Durability Assessment		5a. CONTRACT NUMBER			
		5b. GRANT NUMBER			
		5c. PROGRAM ELEMENT NUMBER			
6. AUTHOR(S)		5d. PROJECT NUMBER			
		5e. TASK NUMBER			
		5f. WORK UNIT NUMBER			
7. PERFORMING ORGANIZATION NAME(S) AND ADDRESS(ES) Boeing		8. PERFORMING ORGANIZATION REPORT NUMBER			
9. SPONSORING/MONITORING AGENCY NAME(S) AND ADDRESS(ES)		10. SPONSOR/MONITOR'S ACRONYM(S)			
		11. SPONSOR/MONITOR'S REPORT NUMBER(S)			
12. DISTRIBUTION/AVAILABILITY STATEMENT Approved for public release, distribution unlimited					
13. SUPPLEMENTARY NOTES The original document contains color images.					
14. ABSTRACT					
15. SUBJECT TERMS					
16. SECURITY CLASSIFICATION OF:			17. LIMITATION OF ABSTRACT UU	18. NUMBER OF PAGES 29	19a. NAME OF RESPONSIBLE PERSON
a. REPORT unclassified	b. ABSTRACT unclassified	c. THIS PAGE unclassified			



Acknowledgements

Jointly accomplished by a BOEING Led Team and the U.S. Government under the guidance of NAST

Work funded by DARPA/DSO and administered by NAST through TIA N00421-01-3-0098

Acknowledge the support of Dr. Steve Wax and Dr. Leo Christodoulou of DARPA/DSO

Specific to this presentation:

- Prof. Yasushi Miyano of Kanazawa Institute of Technology
- Prof. Stephen W. Tsai and Prof. Richard M. Christensen of Stanford University
- Prof. Sung Kyu Ha of Hanyang University



Objective

The goal of the AIM-C program

- (1) Accelerate the insertion of new materials and processes
- (2) Evaluate the effects of material, processing, and design on the performance of composite structures

Our objective is to add the capability to analyze

- **Environmental effects**

- Temperature
- Moisture

- **Durability**

- Creep Loading
- Fatigue Loading
- Residual Strength

Approach

Our approach is based on the following methods

1. Accelerated Testing Methodology

- Accelerated durability assessment
- Evaluate effects of temperature and loading on strength

2. Strain Invariant Failure Theory (SIFT)

- Relate fiber and matrix to composite structures
- Significant reduction in required durability tests
- Simplifies effects of moisture and temperature

Typical Approach to Durability

Fatigue, creep, or static loading

Cycles to failure

~~Time to failure~~ ⇒ ignored

Temperature ⇒ fixed

Moisture ⇒ fixed

Ply orientations ⇒ fixed

Applied stress state ⇒ fixed

S-N Curve Approach

applicable only to limited ply orientations, loads, temperatures, etc.

Geometry

“Static” Failure Analysis

optimized for static strength and later checked for durability

Durability data applicable only to intended applications

Our Approach to the Durability of Composites

Fatigue, creep, or static loading

Cycles to failure

Time to failure

Temperature

Moisture

**Accelerated Testing
Methodology**

applicable to wide ranges
of loads, temperatures, etc.

Ply orientations

Applied stress state

Geometry

Failure Analysis

SIFT modified for time-
and temperature-dependence

Durability data applicable to wide ranges of applications

Accelerated Testing Methodology

Series of tests at elevated temperature

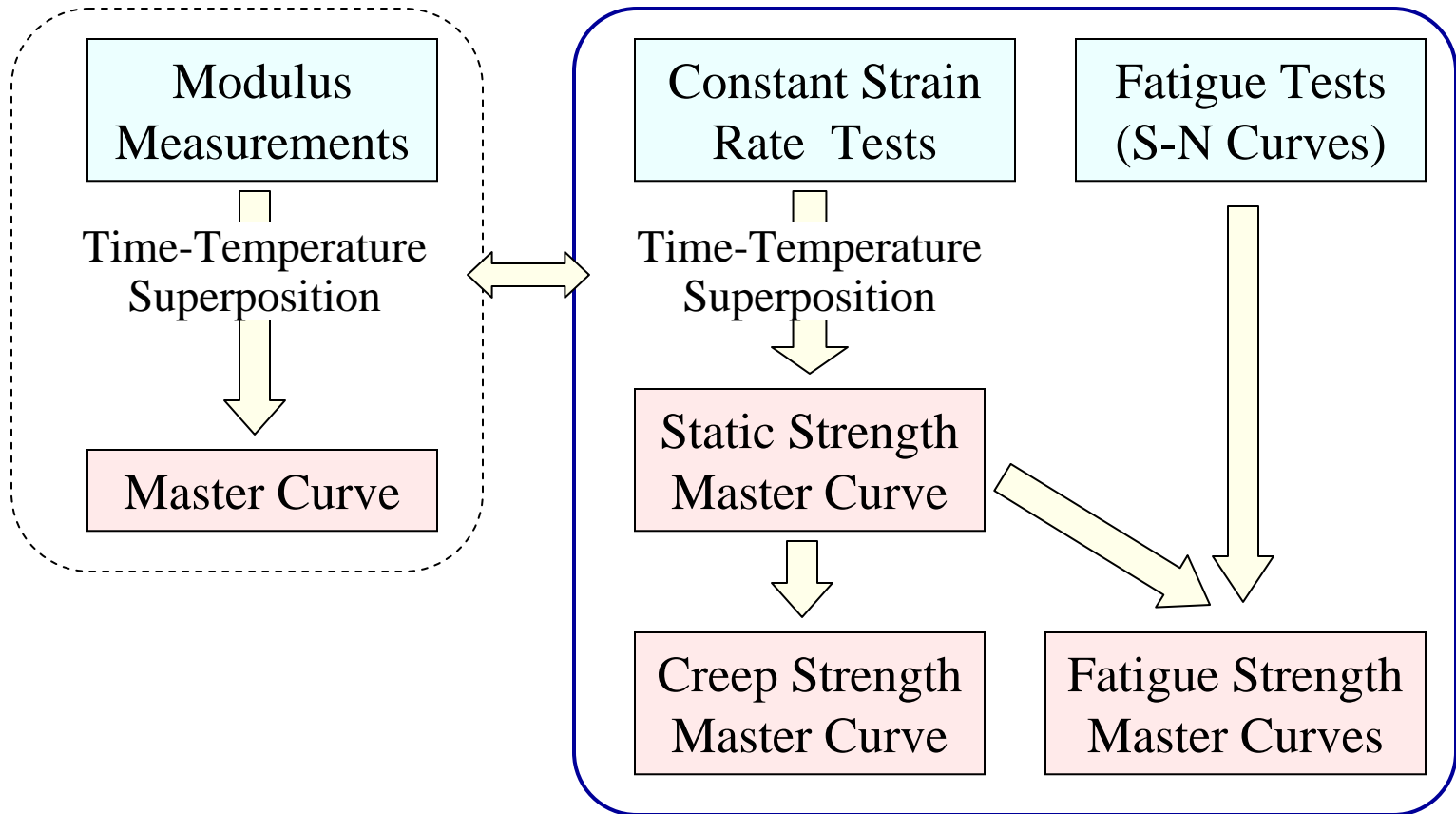

Predictions for wide ranges of temperature and time to failure

Time-Temperature Superposition Principle

Assumption: Same curve for any temperature = Master Curve

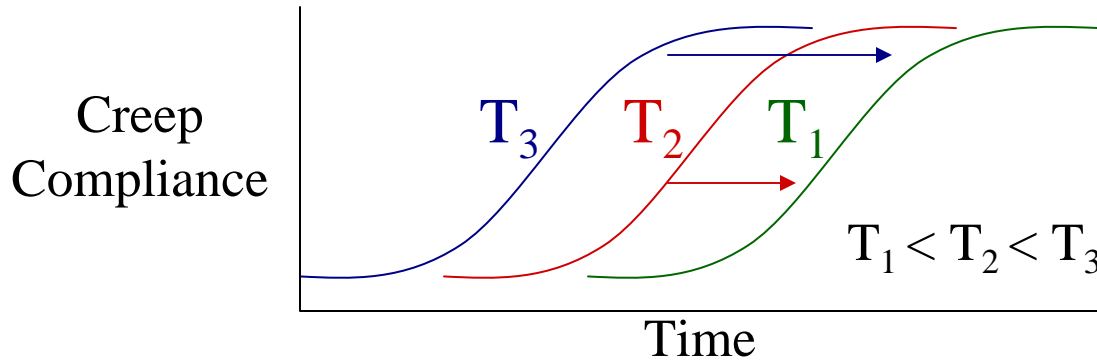

All curves can be superposed by horizontal shift

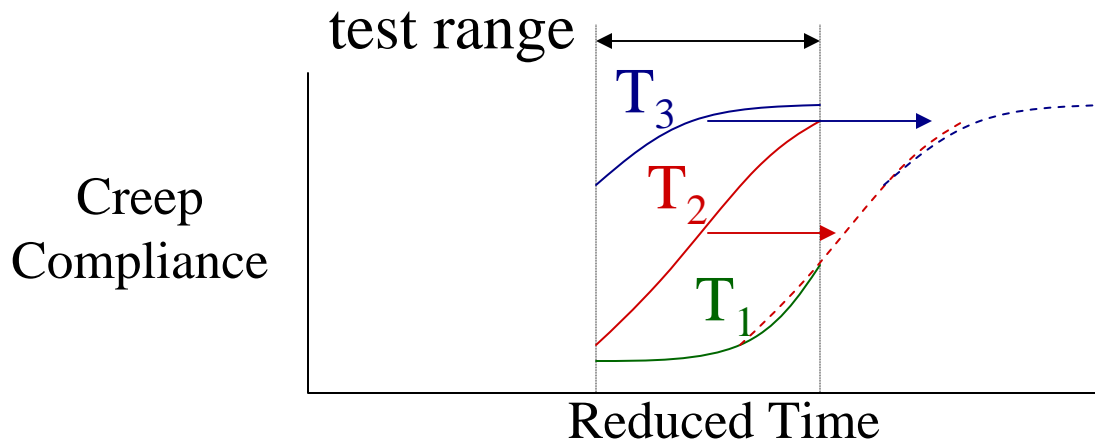

Master curve can be determined from curves at different temperatures

Well established principle for viscoelastic materials

Time-Temperature Superposition on Strength

Assumption: Same curve for any temperature = Master Curve

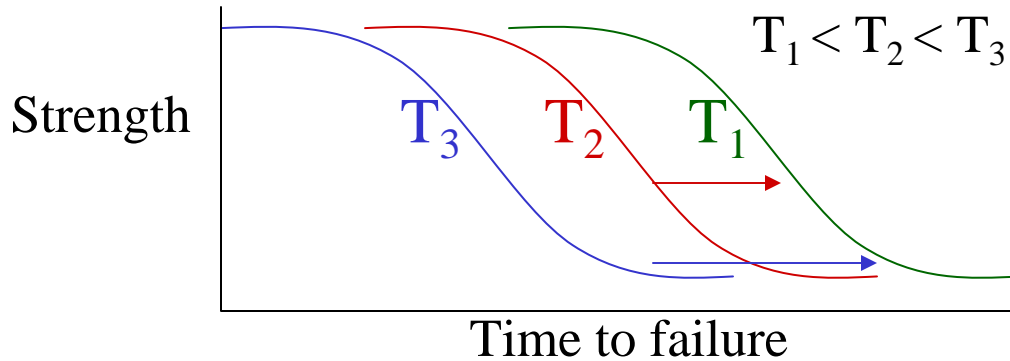

All curves can be superposed by horizontal shift

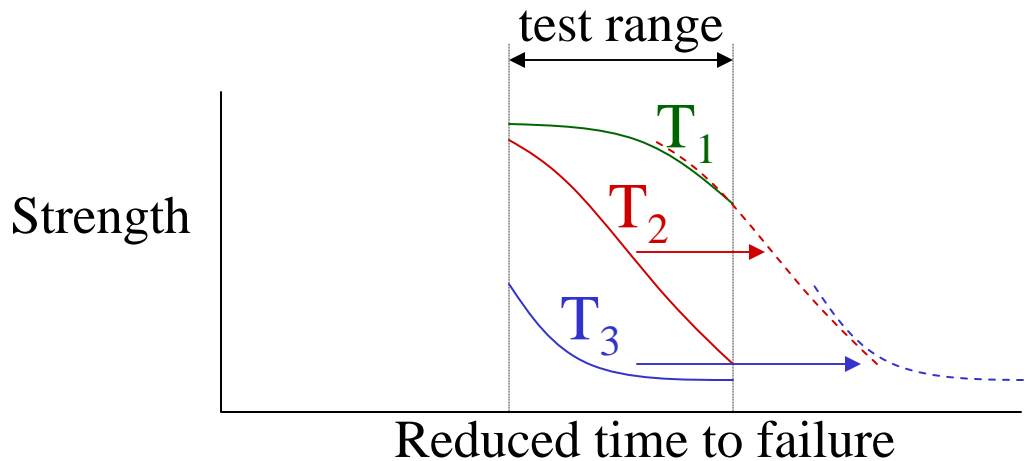

Master curve can be determined from curves at different temperatures

Master Curve of Static Strength

CFRP Bolted Joint Tensile Test (Miyano)

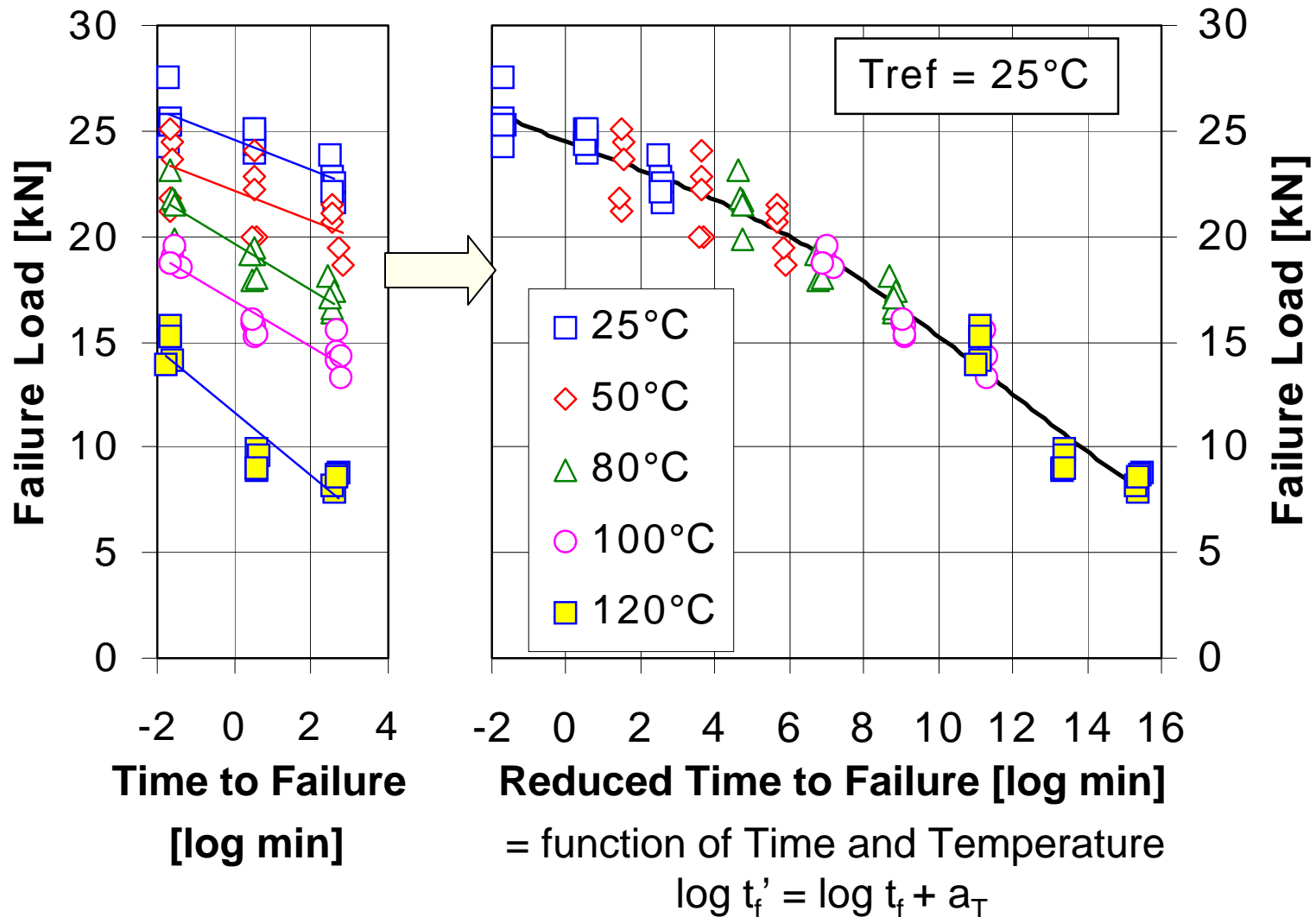

Time Temperature Shift Factors

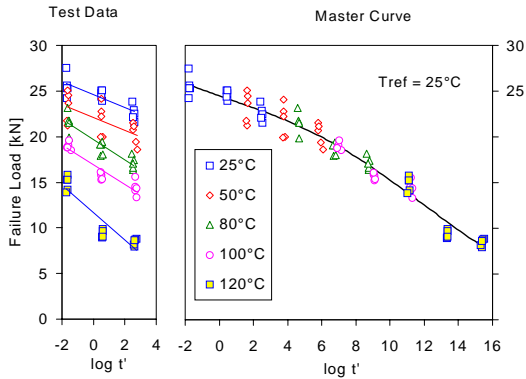

- CFRP Bolted Joint Strength
- Creep Compliance of CFRP
- △ Creep Compliance of Resin
- × Storage Modulus of Resin

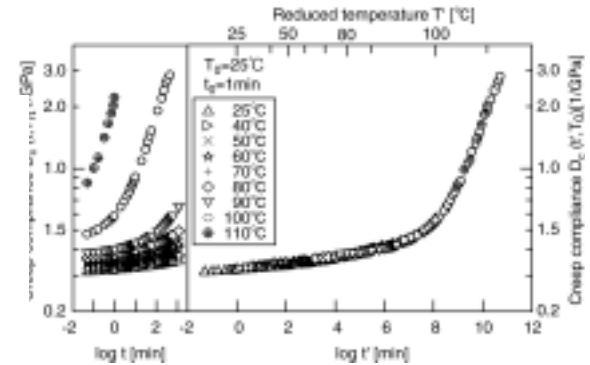

Temperature [°C]

CFRP Bolted Joint Strength

Creep Compliance of Resin

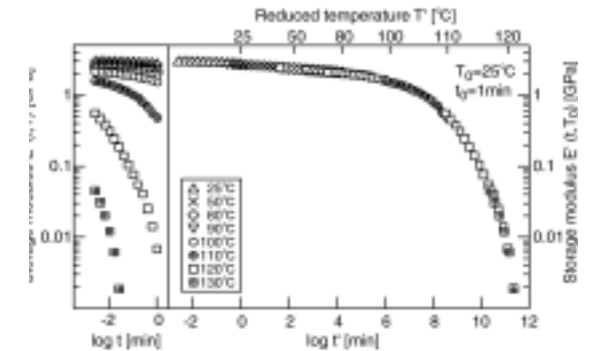
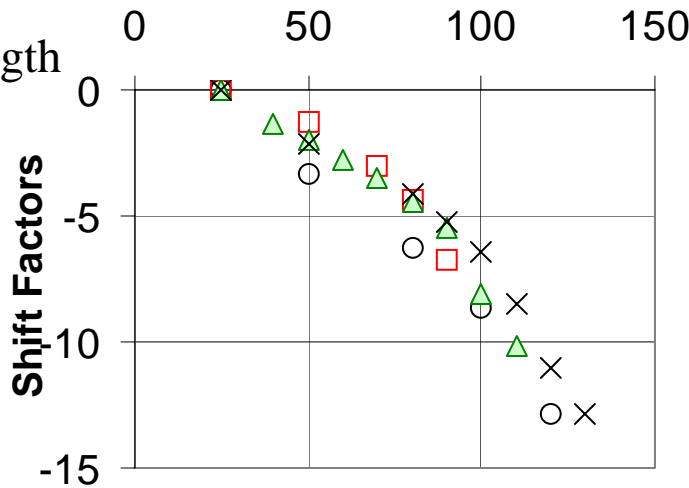
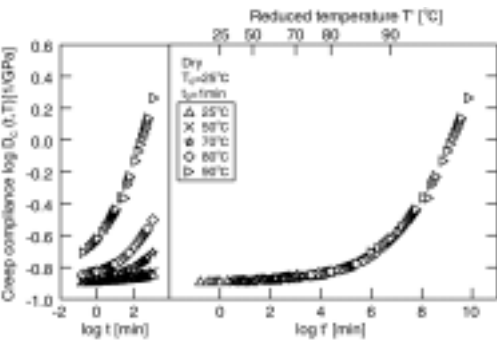

Creep Compliance of CFRP

Storage Modulus of Resin

Same shift factors for various cases with common resin system

Relate Static Strength and Creep Life

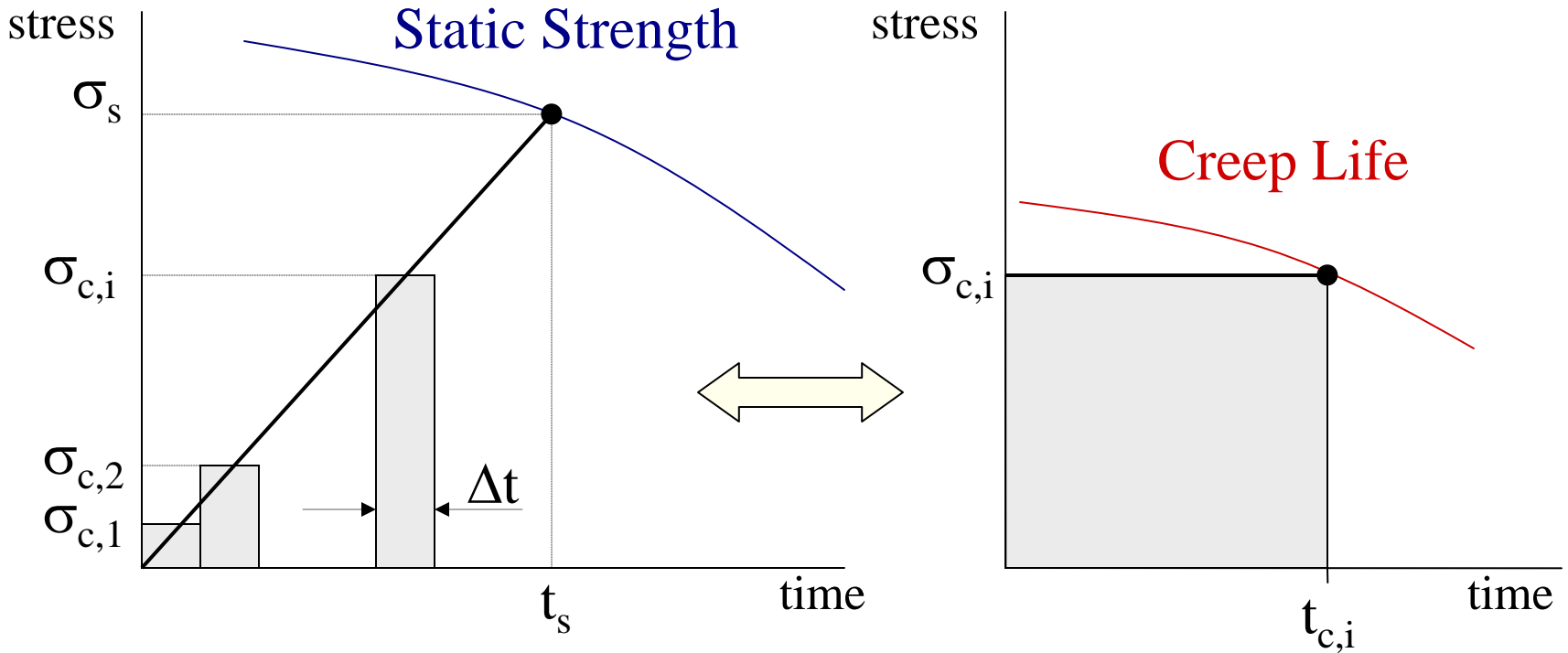

Linear Cumulative Damage Law with respect to time

$$\frac{\Delta t}{t_{c,1}} + \frac{\Delta t}{t_{c,2}} + \dots + \frac{\Delta t}{t_{c,n}} = 1$$

Simple relation between creep life and static strength

Master Curve of Creep Life

CFRP Bolted Joint Tensile Creep

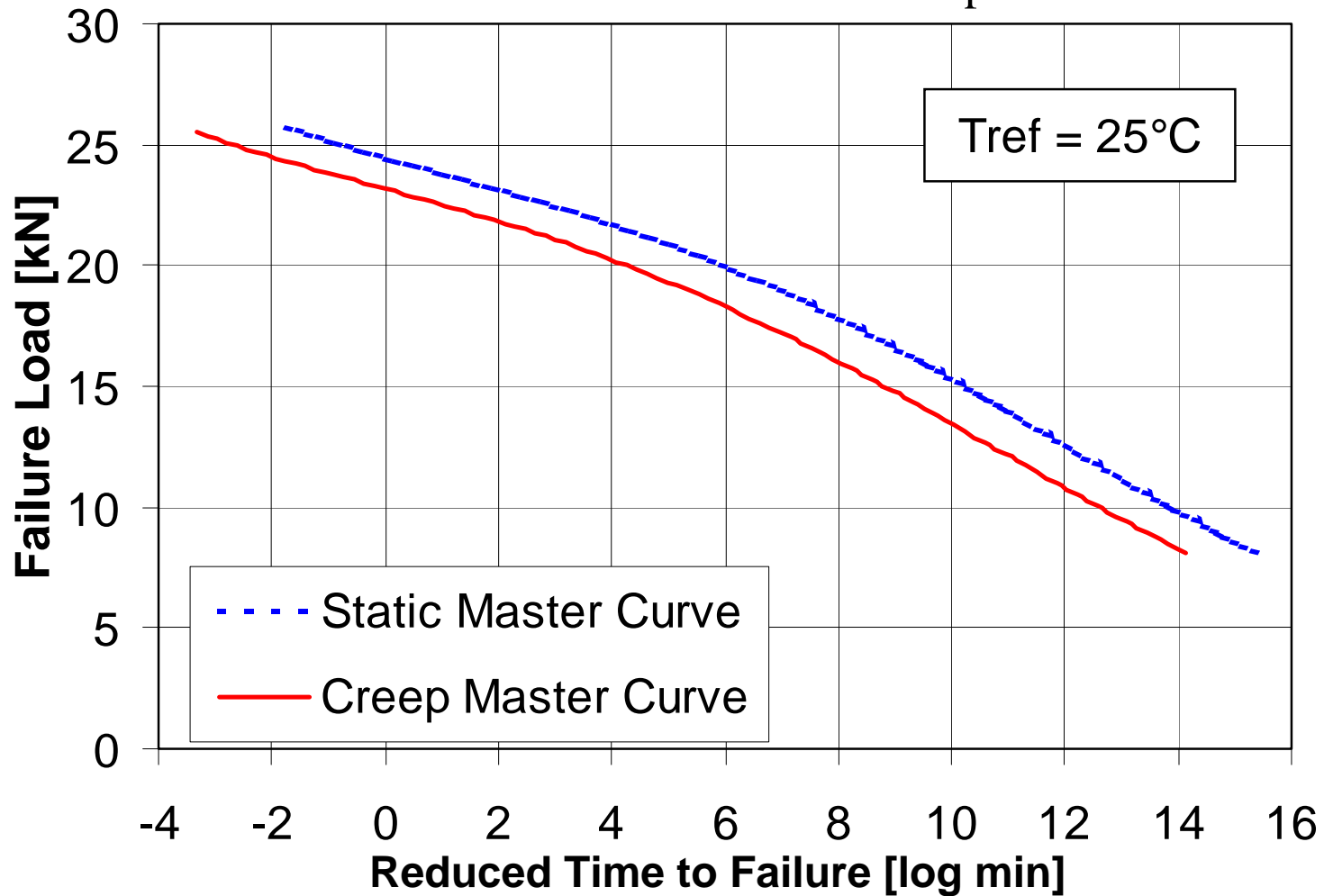

Time to failure at 25°C

1min 100min 1wk 2yrs 190yrs

Time to failure at 50°C

1min 100min 1wk 2yrs 190yrs

Creep Predictions and Measurements

CFRP Bolted Joint Tensile Creep Test (Miyano)

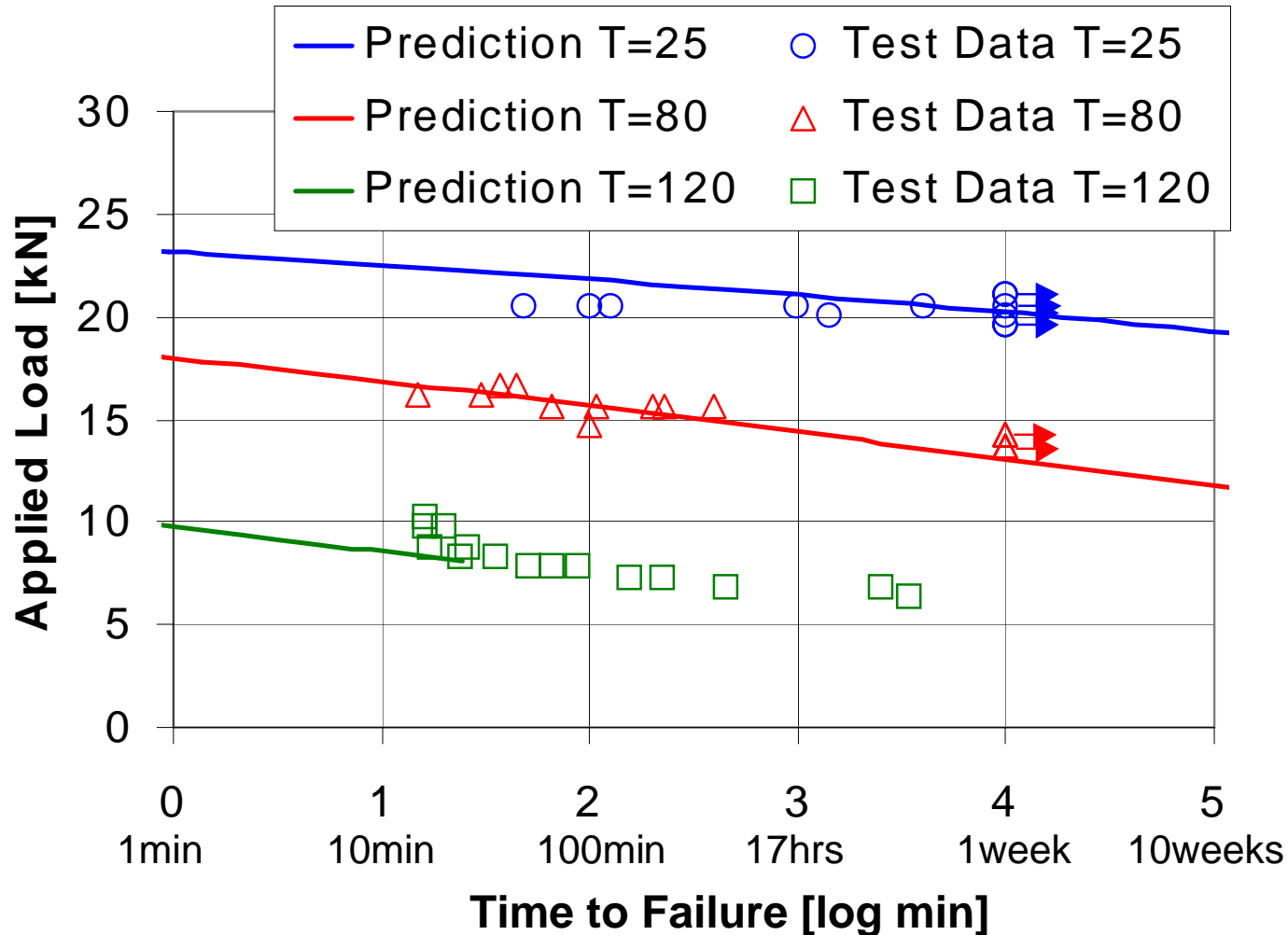

Creep life is predicted from series of constant-strain-rate tests

Creating the Fatigue Master Curves

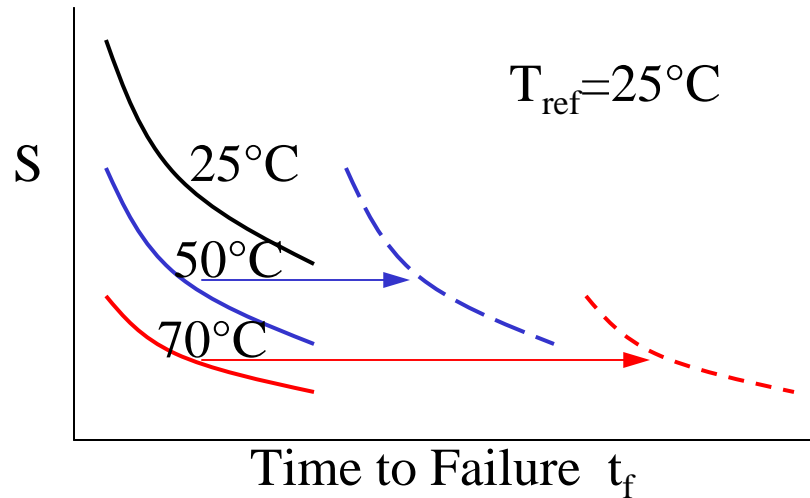
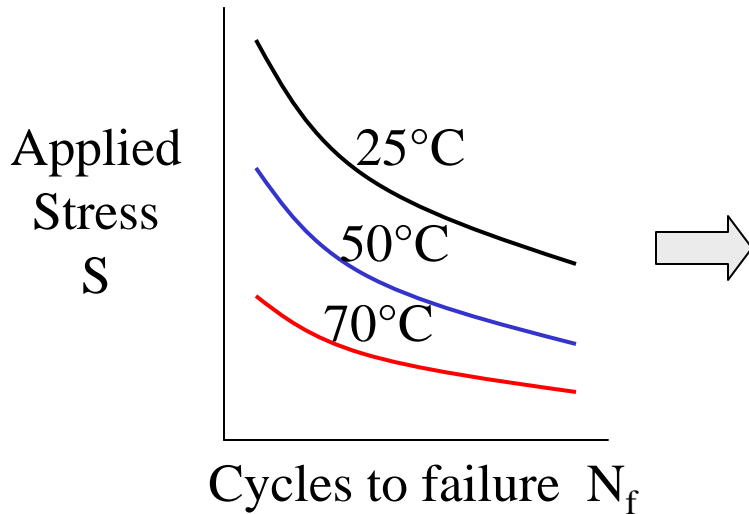

1. Calculate time to failure
 $t_f = N_f / 60f$
2. Shift $S-t_f$ curves
3. Connect constant N_f

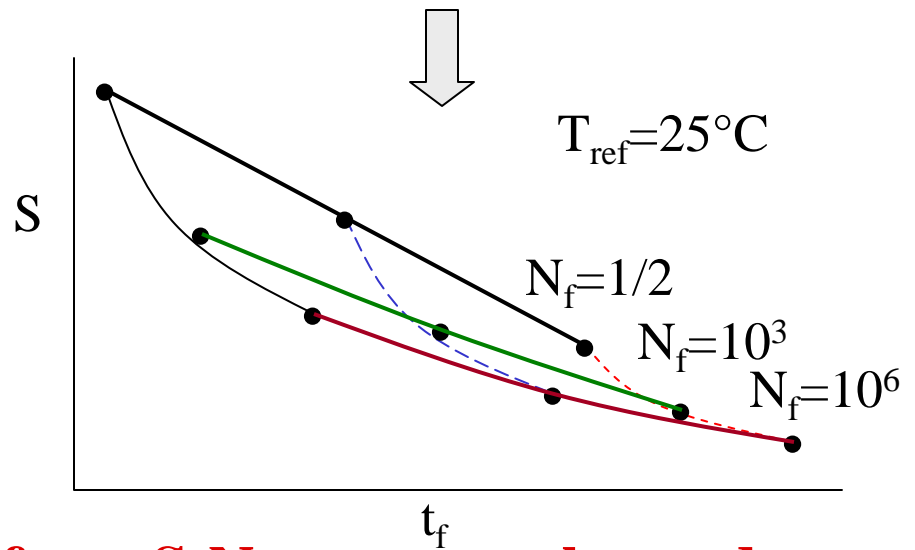

Predict long-term fatigue from S-N curves at elevated temperatures

Fatigue Master Curves

CFRP Bolted Joint Tensile Fatigue Strength (Miyano)

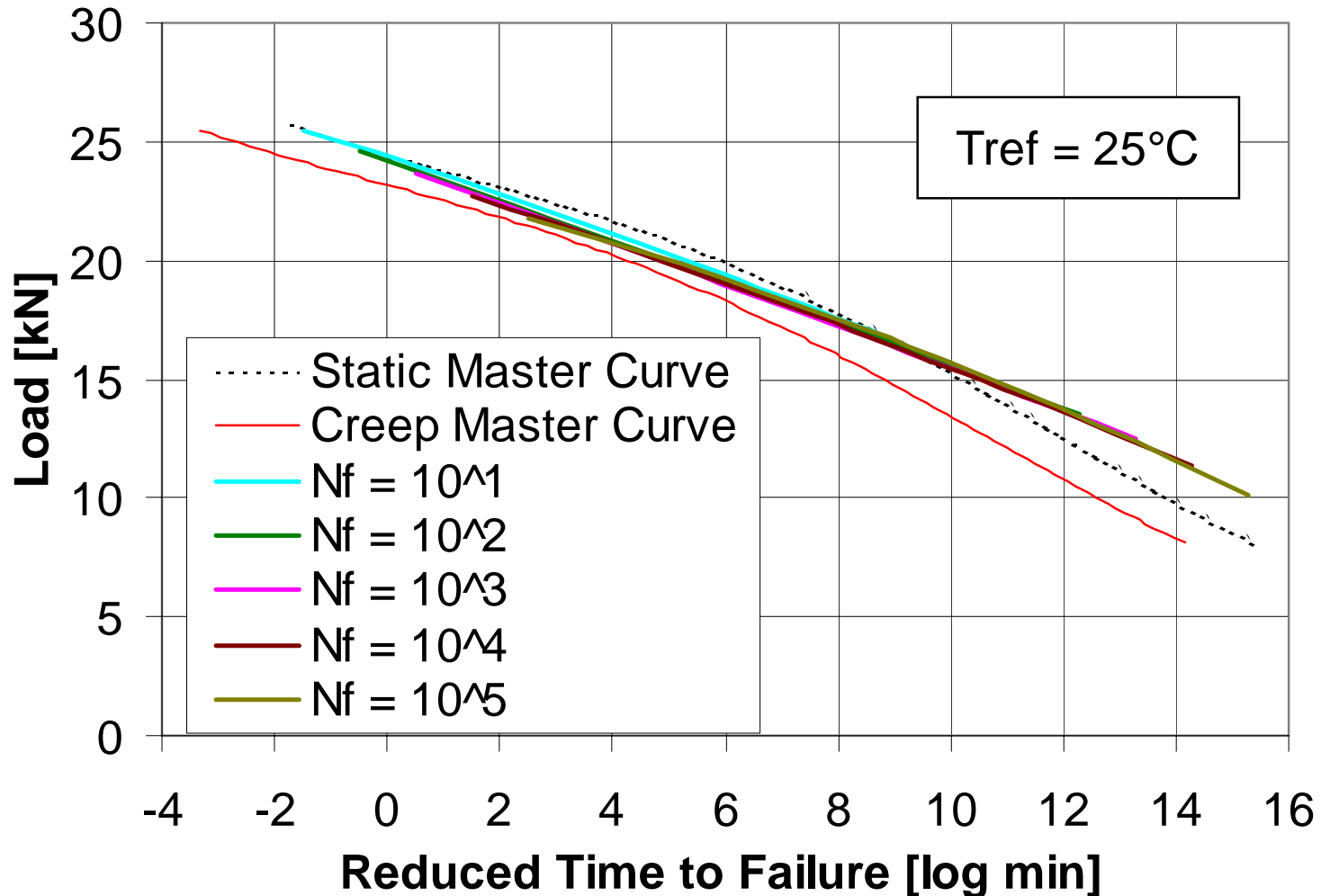

Fatigue Predictions and Measurements

CFRP Bolted Joint Fatigue Strength - Frequency Effect (Miyano)

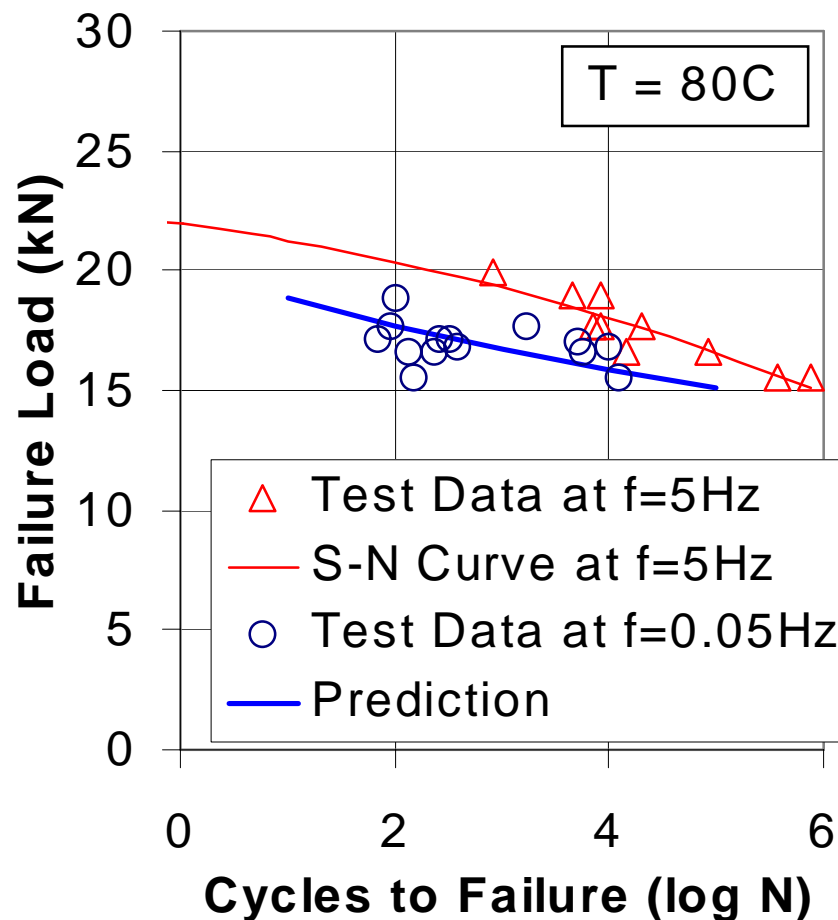
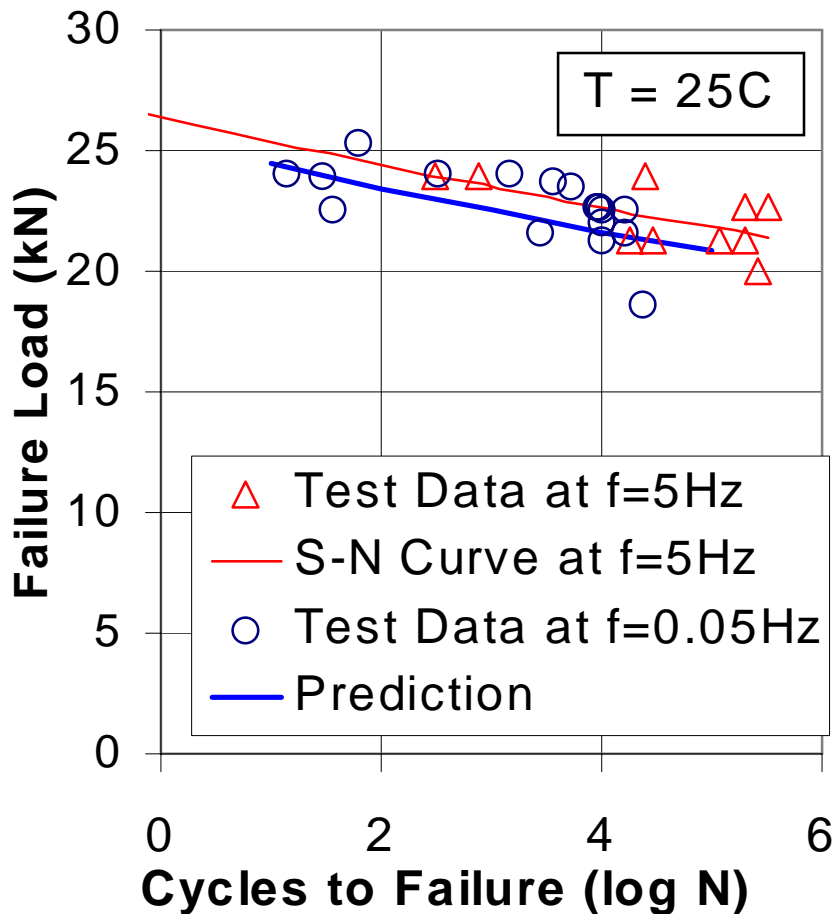

Frequency effect on fatigue strength is correctly predicted

Cumulative Damage Law

Miner's Rule accumulates damage due to load **cycles**

Robinson's Rule accumulates damage due to loading **time**

Applied Stress

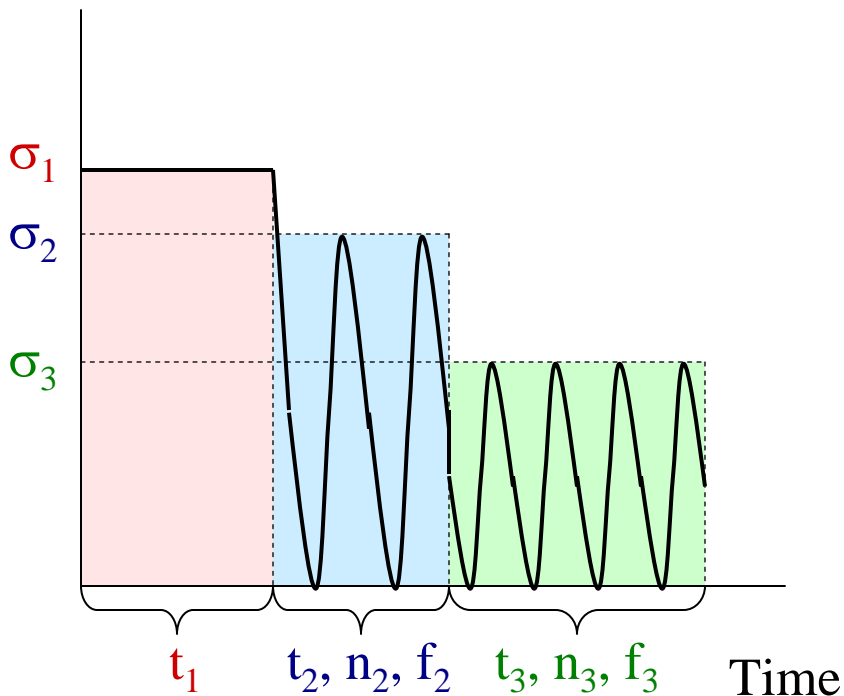

Strength

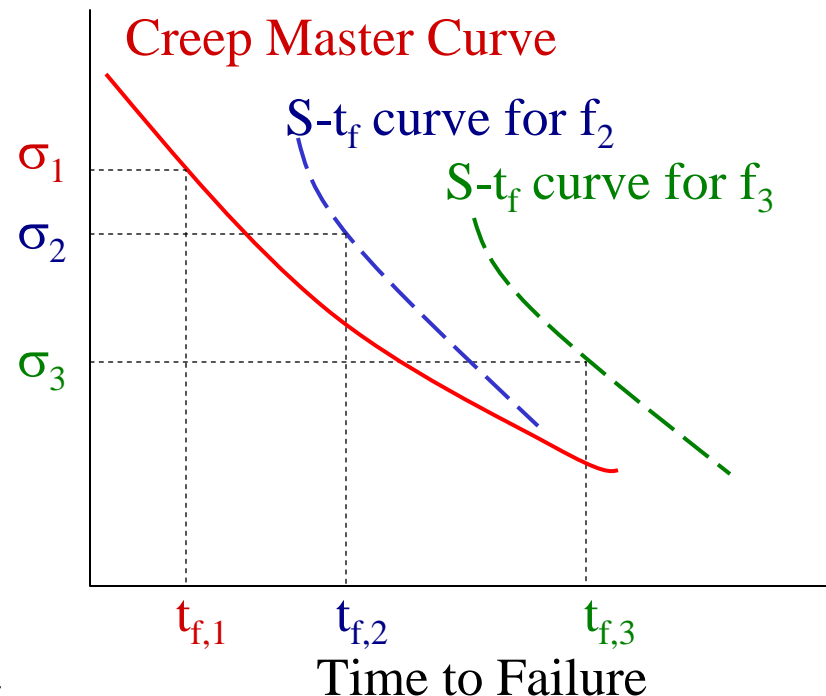

Robinson's Rule: $t_1 / t_{f,1} + t_2 / t_{f,2} + t_3 / t_{f,3} + \dots = 1$

Limitation of the Methodology

Current limitations of the Accelerated Testing Methodology are

- Series of constant-strain-rate tests and fatigue tests must be performed for **each ply orientations and test configurations**
- Tests must be performed for both **dry** and **wet** conditions
- Links between the resin and composite properties are observed but cannot be explained

Why Combine with SIFT

SIFT will provide keys to

- Predict the strength of complex structures from basic properties
- Reduce the numbers of durability tests
- Link the resin properties to composite properties
- Effect of moisture and other degradations are easier to analyze at the resin level

Strain Invariant Failure Theory

Detailed 3D FEA of complex structures
combined with simple strain-based failure criterion

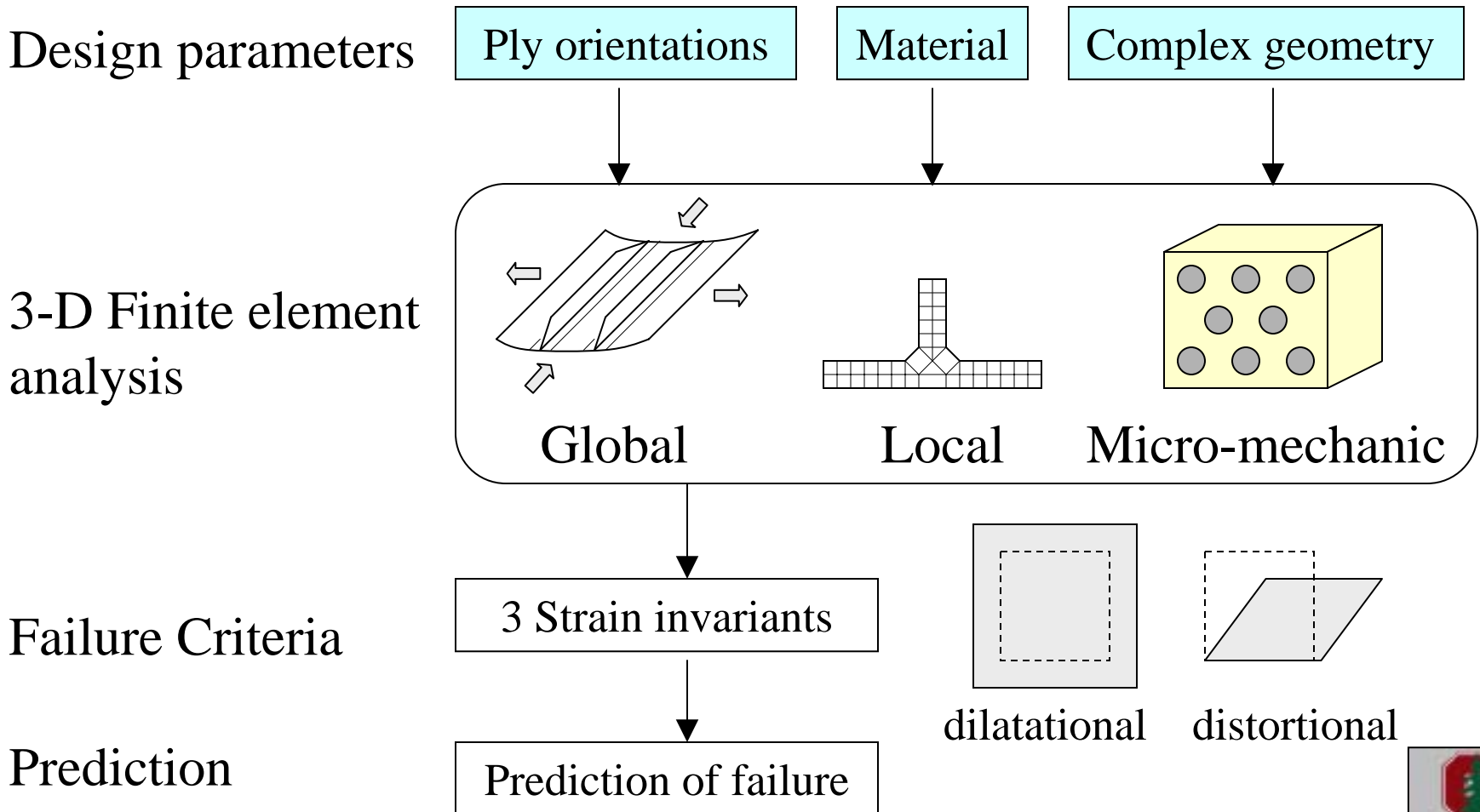

Micro-Mechanical Analysis in SIFT

SIFT evaluates local strain states of fiber and matrix through extensive Micromechanical analysis

Advantages for our durability analysis

- Significant reduction of the required durability tests
- Easier to analyze the **temperature** and **moisture** effects of resin
- Generate ply properties: A bottom up tool

Example of the Square Array Model and Hexagonal Array Model (Ha)

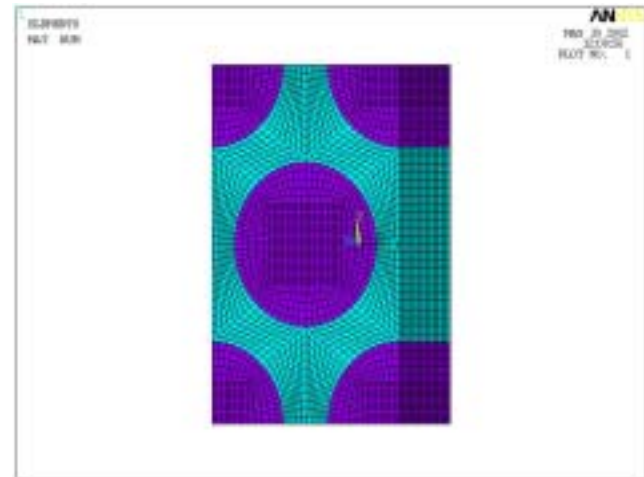
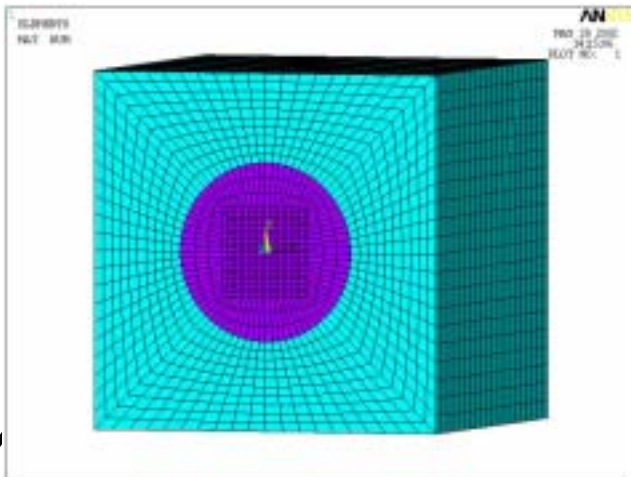

SIFT Analysis Procedure

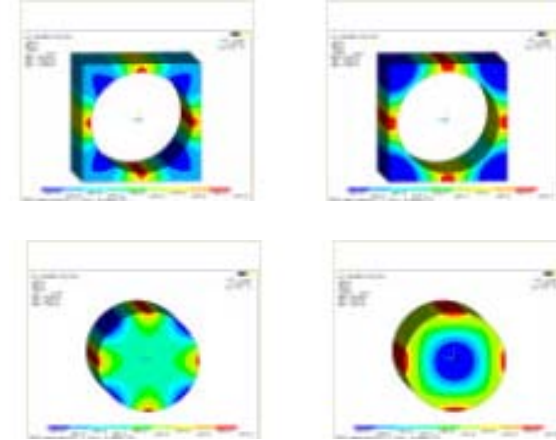
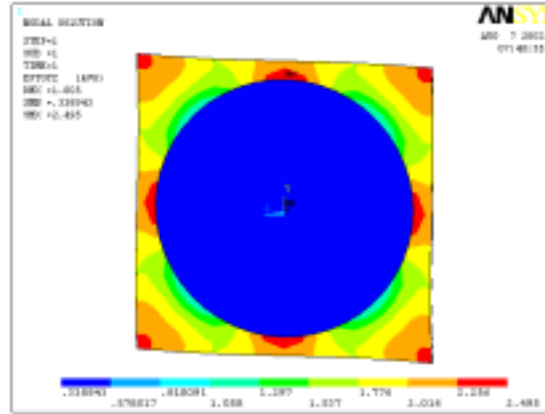
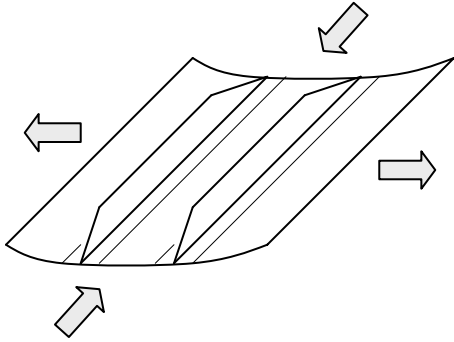

3-D macro strains
due to mechanical
and thermal load

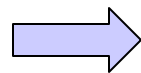

3-D micro strains
at various locations
in the fiber and resin

+

Micro thermal strains
due to CTE mismatch
of fiber and resin

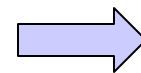

Strain invariants
in the resin
and in the fiber

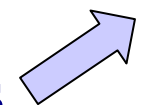

compare

Critical invariants

Electronic Carpet Plot

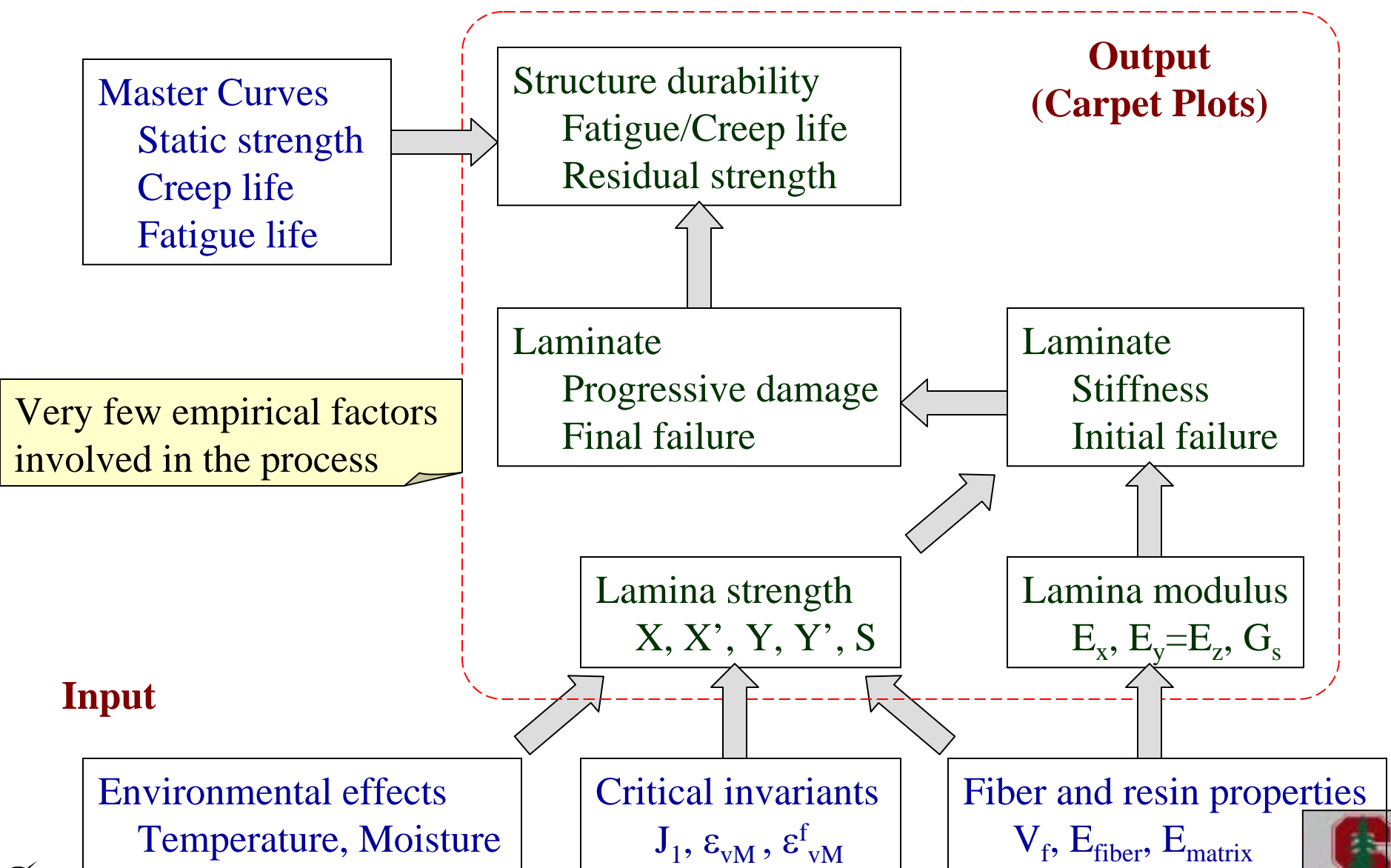

Predicted Ply Properties

- Material: IM7/Epoxy, $E_f/E_m=92$
- Square and Hexagonal Micromechanics Model
- Compared with the Modified Rule of Mixture

Transverse modulus / Resin modulus

$$E_2/E_m$$

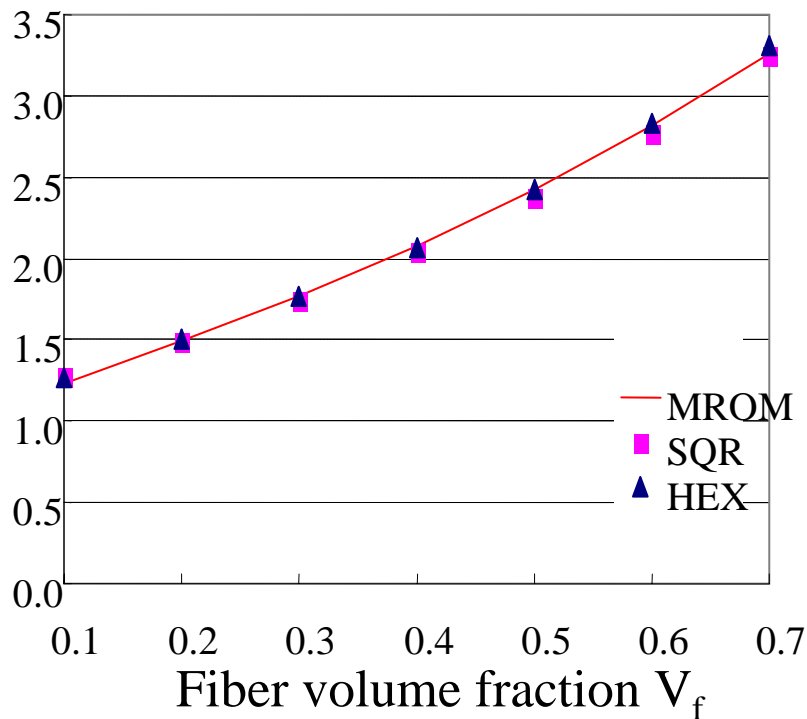

Longitudinal CTE / Fiber CTE

$$\alpha_1/\alpha_f$$

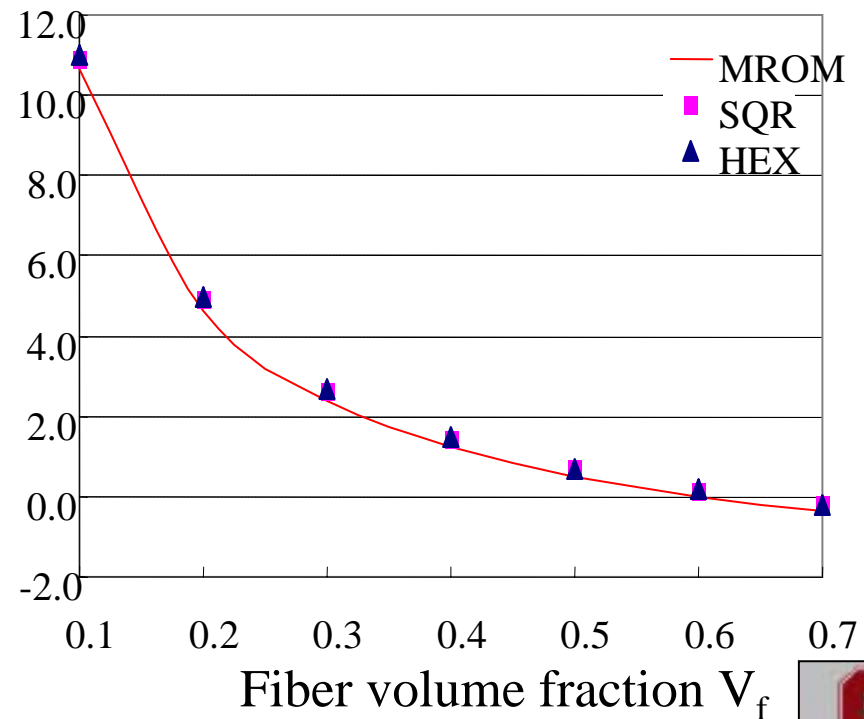

Ply Strength Predicted from Resin Properties

Test data and master curve of resin tensile strength (828resin)

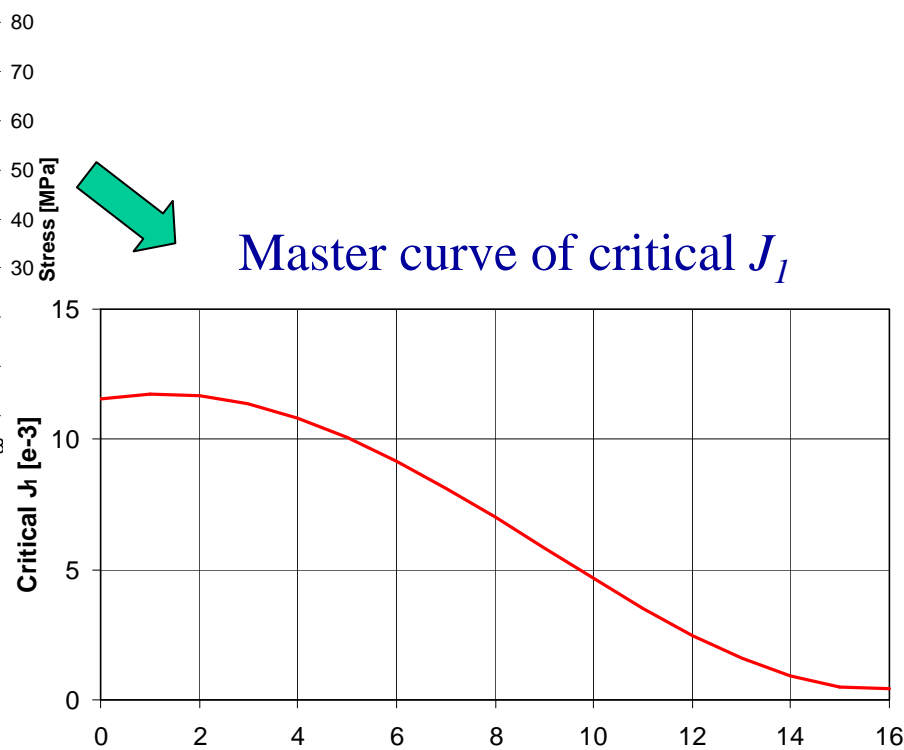
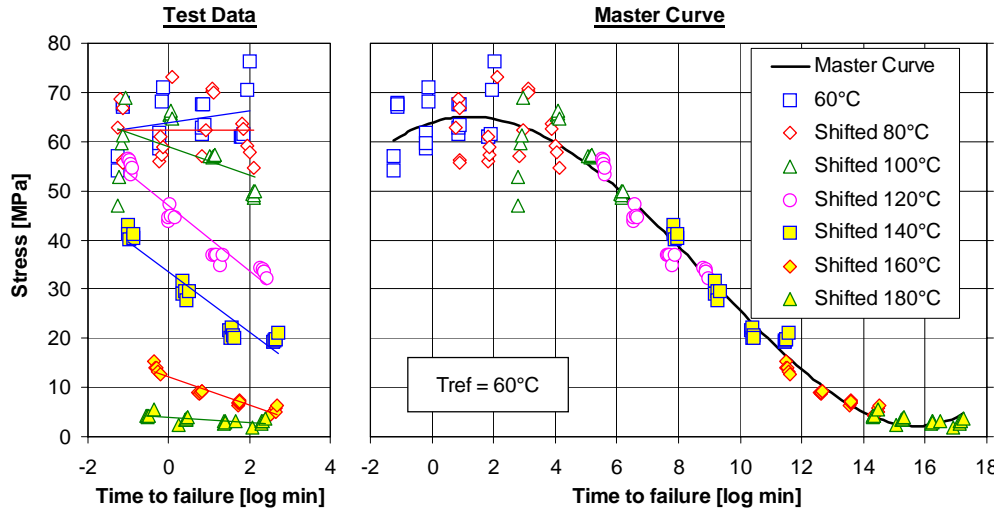

Master curve of critical J_1

Reduced time to failure [log min] = function of time and temperature

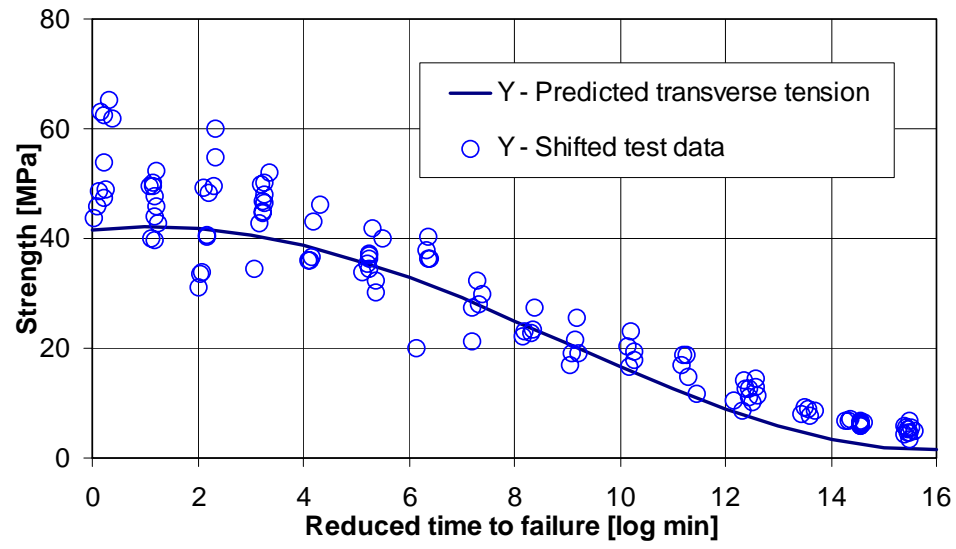

Master curve of transverse tensile strength of composite laminates (T300/828) (with test data for comparison)



Predicted Creep Life

Based on linear cumulative damage law
and time-dependence of strength

Long term creep life can be
predicted from series of
less time-consuming
constant strain rate tests

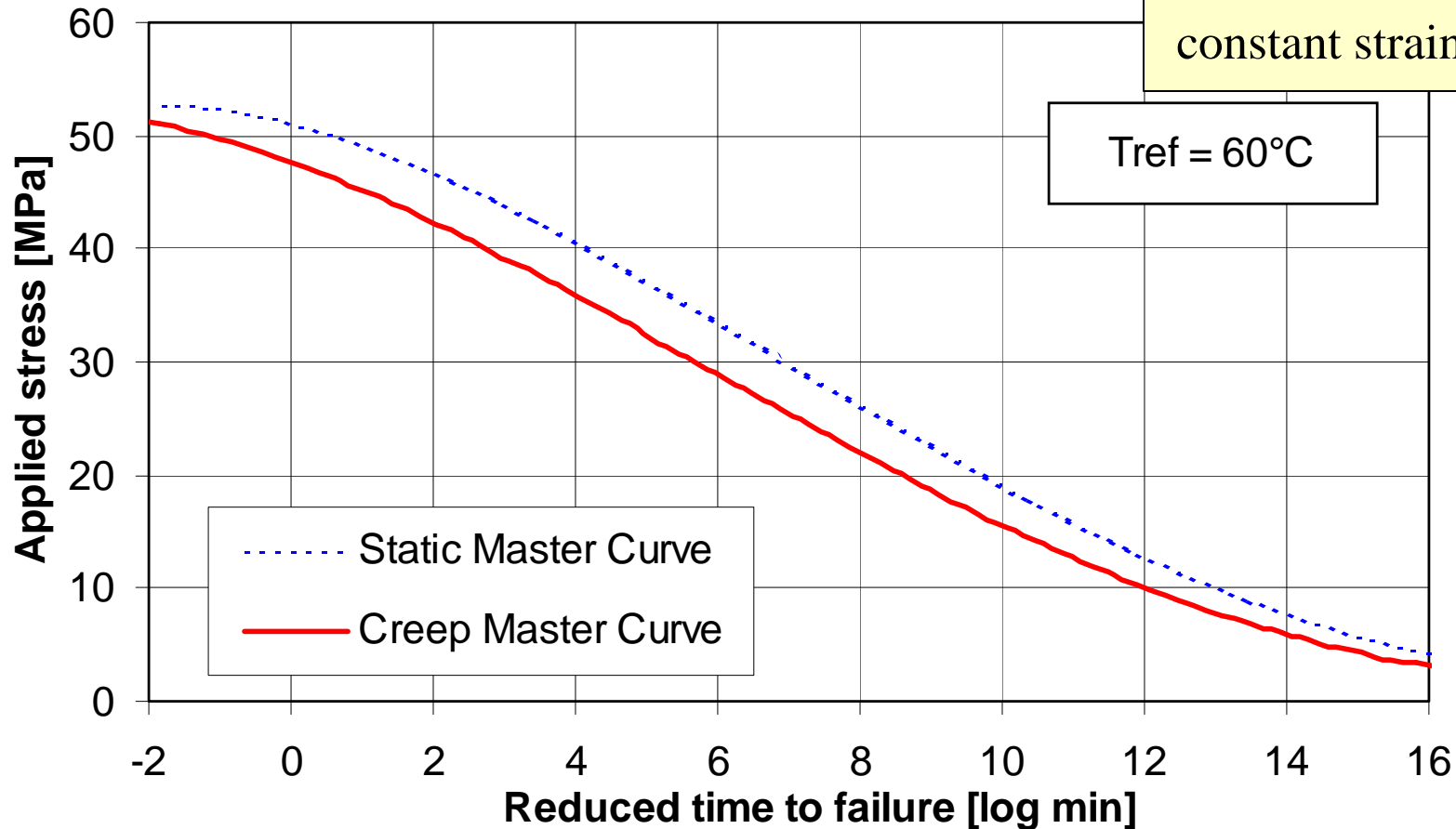

1min 100min 1wk 2yrs 190yrs

time to failure at 60°C

1min 100min 1wk 2yrs 190yrs

time to failure at 80°C

Residual Strength after Creep Loading

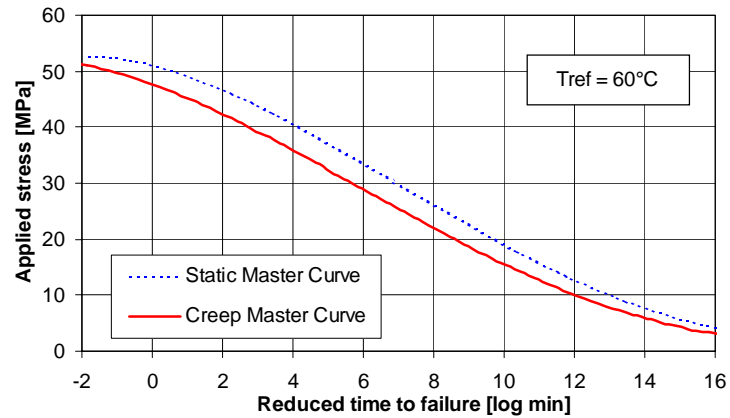

Master curve of static strength
Master curve of creep life

Based on linear cumulative damage law
and time-dependence of strength

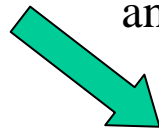

Residual static strength after creep loading

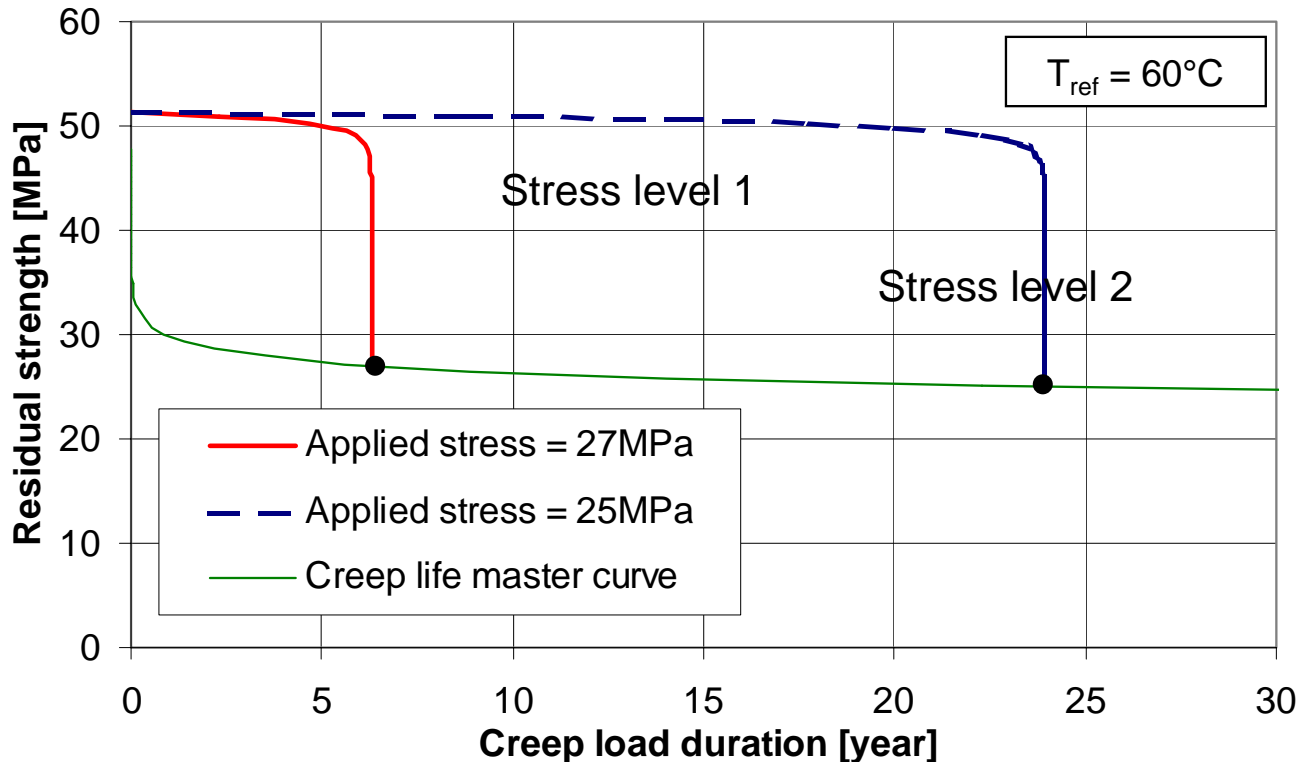

Conclusion

- Accelerated Testing Methodology (ATM) is the key to the long-term material characterization of composite materials
- The generated fatigue and creep master curves are applicable to wide ranges of temperature, time to failure, and loading conditions, making them ideal building blocks of material durability database.
- ATM / SIFT combination can be used to predict the durability of complex composite structures based on the durability database of the basic material properties.