



# Accelerated Insertion of Materials – Composites



***Presented at***  
**Tech Trends 2002**  
**by Gail Hahn**  
**Boeing Phantom Works**  
**314-233-1848**  
[gail.l.hahn@boeing.com](mailto:gail.l.hahn@boeing.com)  
**3 April 2002**

**Jointly accomplished by BOEING and the U.S. Government  
under the guidance of NAST**

*This program was developed under the guidance of Dr. Steve Wax and Dr. Leo Christodoulou of DARPA. It is under the technical direction of Dr. Ray Meilunas of NAVAIR.*



# Report Documentation Page

Form Approved  
OMB No. 0704-0188

Public reporting burden for the collection of information is estimated to average 1 hour per response, including the time for reviewing instructions, searching existing data sources, gathering and maintaining the data needed, and completing and reviewing the collection of information. Send comments regarding this burden estimate or any other aspect of this collection of information, including suggestions for reducing this burden, to Washington Headquarters Services, Directorate for Information Operations and Reports, 1215 Jefferson Davis Highway, Suite 1204, Arlington VA 22202-4302. Respondents should be aware that notwithstanding any other provision of law, no person shall be subject to a penalty for failing to comply with a collection of information if it does not display a currently valid OMB control number.

1. REPORT DATE <b>2002</b>		2. REPORT TYPE <b>N/A</b>		3. DATES COVERED <b>-</b>	
4. TITLE AND SUBTITLE <b>Accelerated Insertion of Materials Composites Presented at Tech Trends 2002</b>				5a. CONTRACT NUMBER	
				5b. GRANT NUMBER	
				5c. PROGRAM ELEMENT NUMBER	
6. AUTHOR(S)				5d. PROJECT NUMBER	
				5e. TASK NUMBER	
				5f. WORK UNIT NUMBER	
7. PERFORMING ORGANIZATION NAME(S) AND ADDRESS(ES) <b>Boeing Phantom Works</b>				8. PERFORMING ORGANIZATION REPORT NUMBER	
9. SPONSORING/MONITORING AGENCY NAME(S) AND ADDRESS(ES)				10. SPONSOR/MONITOR'S ACRONYM(S)	
				11. SPONSOR/MONITOR'S REPORT NUMBER(S)	
12. DISTRIBUTION/AVAILABILITY STATEMENT <b>Approved for public release, distribution unlimited</b>					
13. SUPPLEMENTARY NOTES <b>The original document contains color images.</b>					
14. ABSTRACT					
15. SUBJECT TERMS					
16. SECURITY CLASSIFICATION OF:			17. LIMITATION OF ABSTRACT <b>UU</b>	18. NUMBER OF PAGES <b>17</b>	19a. NAME OF RESPONSIBLE PERSON
a. REPORT <b>unclassified</b>	b. ABSTRACT <b>unclassified</b>	c. THIS PAGE <b>unclassified</b>			



# The AIM-C Team



- Boeing – Seattle and St. Louis – AIM-C CAT, Program Management
- Boeing – Canoga Park – Integration, Propagation of Errors
- **Boeing – Philadelphia** – Effects of Defects

CMT

- Convergent Manufacturing Technologies – Processing
- **Cytec Engineered Materials** – Constituent Materials, Supplier



- **Materials Sciences Corporation** – Structural Analysis Tools
- MIT – Dr. Mark Spearing – Lamina and Durability
- MIT – Dr. David Wallace – DOME, Architecture
- **Northrop Grumman – Bethpage** – Blind Validation
- Northrop Grumman – El Segundo – Producibility Module
- Stanford University – Durability – Test Innovation



**NORTHROP GRUMMAN**





# AIM-C Alignment Tool



*The objective of the AIM-C Program is to provide concepts, an approach, and tools that can accelerate the insertion of composite materials into DoD products*

## AIM-C Will Accomplish This Three Ways

- Methodology** - *We will evaluate the historical roadblocks to effective implementation of composites and offer a process or protocol to eliminate these roadblocks and a strategy to expand the use of the systems and processes developed.*
- Product Development** - *We will develop a software tool, resident and accessible through the Internet that will allow rapid evaluation of composite materials for various applications.*
- Demonstration/Validation** - *We will provide a mechanism for acceptance by primary users of the system and validation by those responsible for certification of the applications in which the new materials may be used.*



# The Plan



- Incorporate methodology into an interface that guides the user and tracks the progress of technology maturation to readiness
- Deliver software in steps toward a useable system as analysis modules are completed
- Demonstrate capability through system validation, compelling technical demonstration, and a 'blind validation' to insure usability

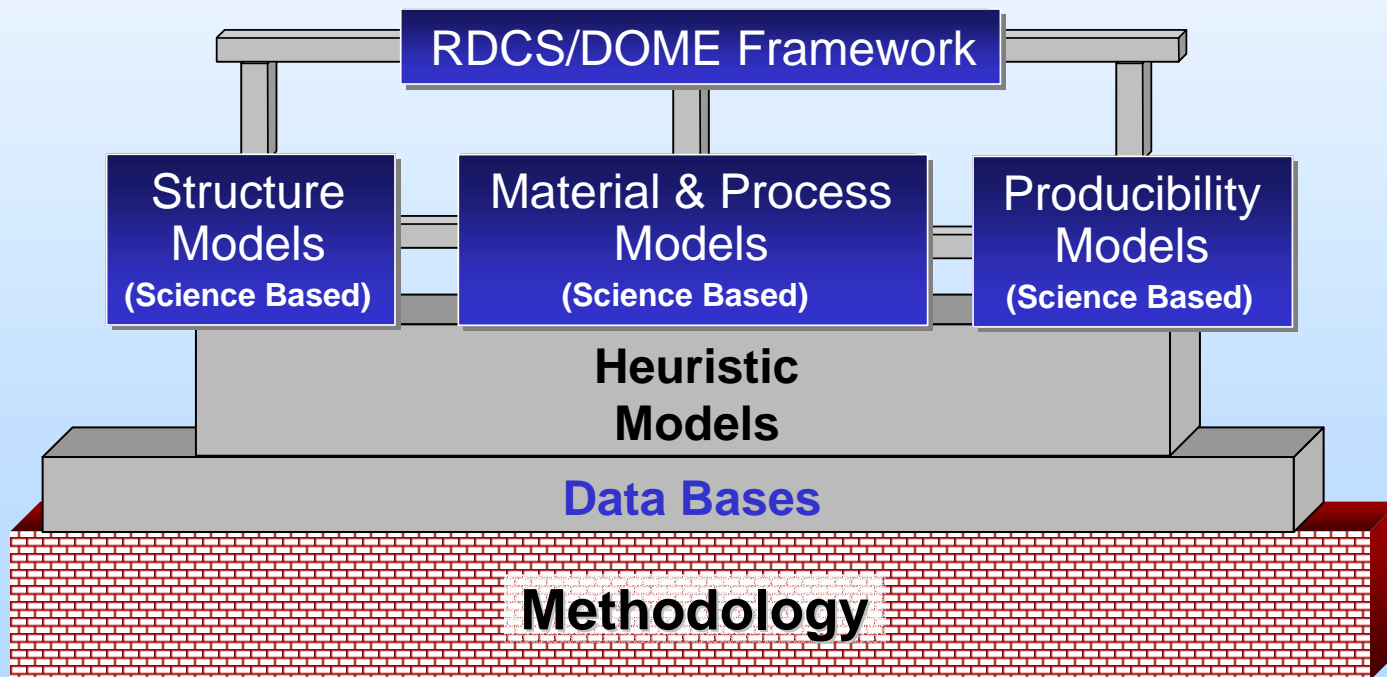

RDCS – Robust Design Computational System  
DOME – Distributed Object Oriented Modeling Environment



# Technology Transition Plan



AIM Product Development    AIM Product Verification    AIM Product Demonstration    AIM Product Refinement    AIM Product Validation    AIM Product Implementation

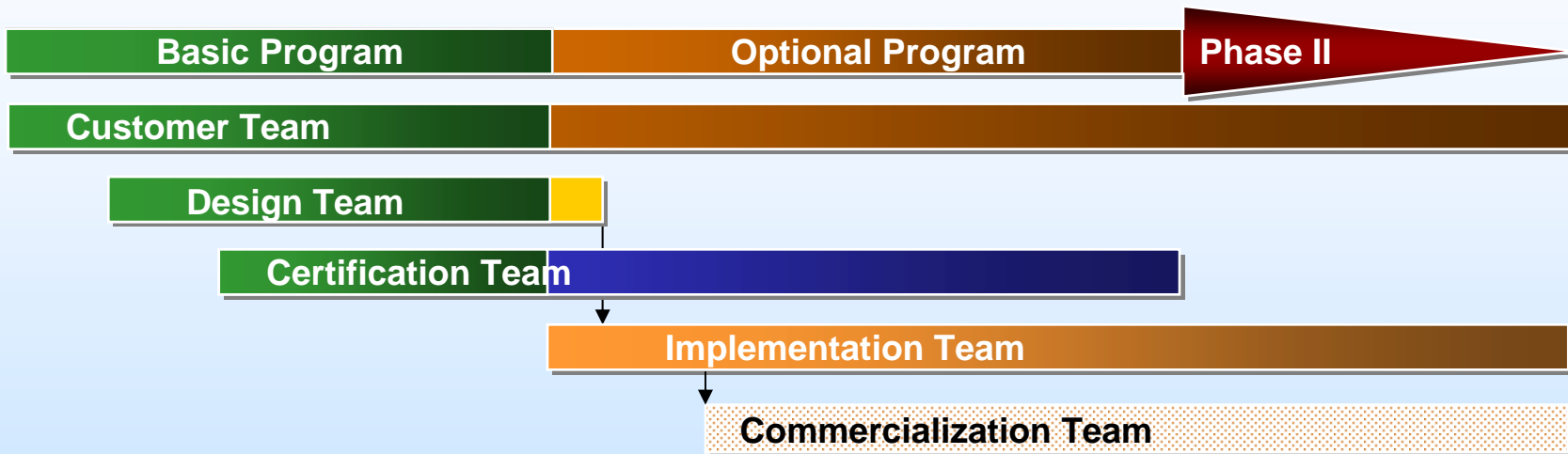

**Customer Team** – To ensure that the product meets the needs of the funding agents

**Design Team** – To ensure acceptance among users in industry

**Certification Team** – To ensure acceptance among the certification agents for structures

**Implementation Team** – To ensure acceptance among the user community

**Commercialization Team** – To ensure commercial support of users





# Leveraging NAVAIR Initiatives



Element of Future Simulation Based Acquisition & Fleet Support Network for Total Ownership Cost Reduction

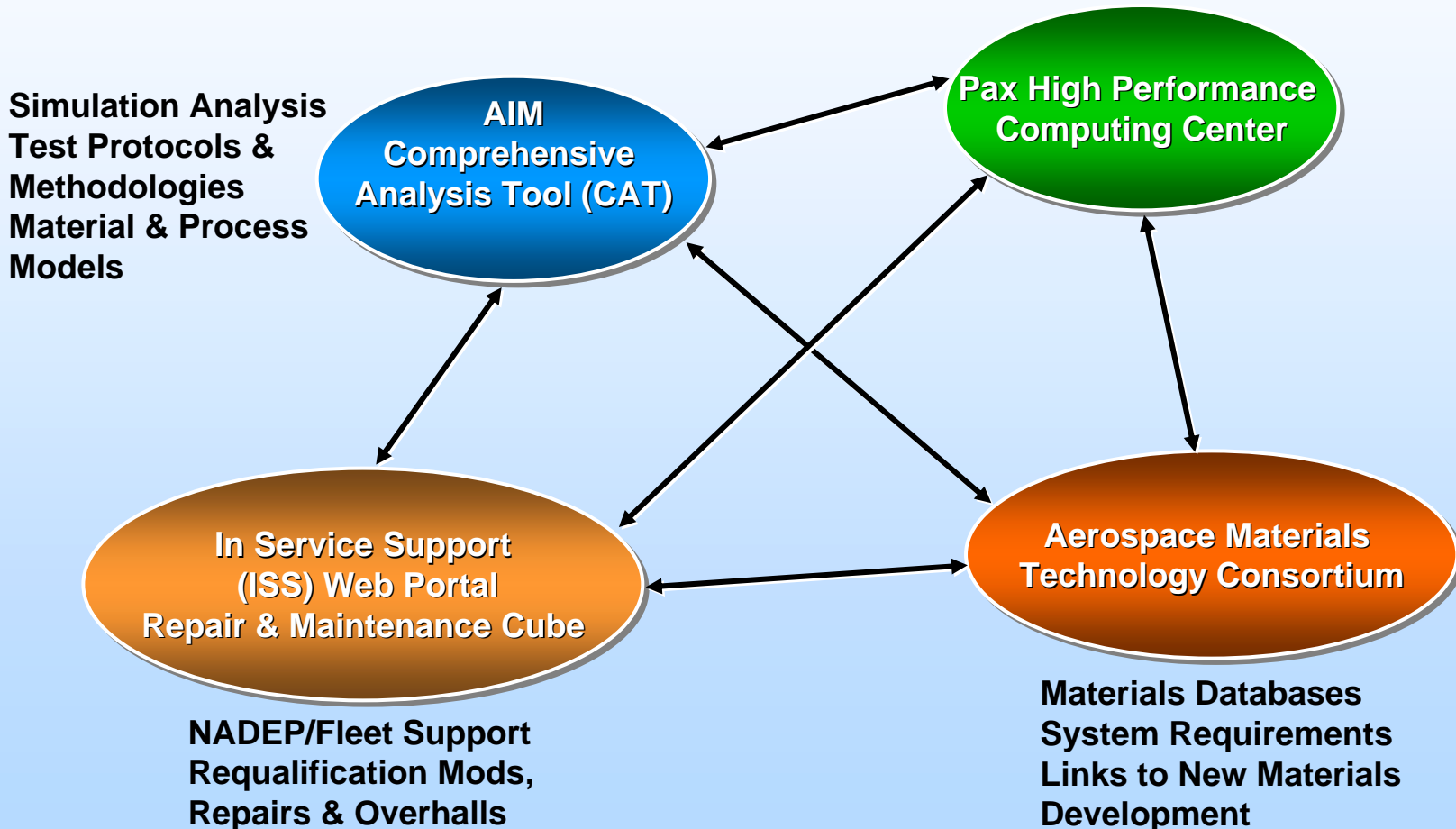



# Architecture Example

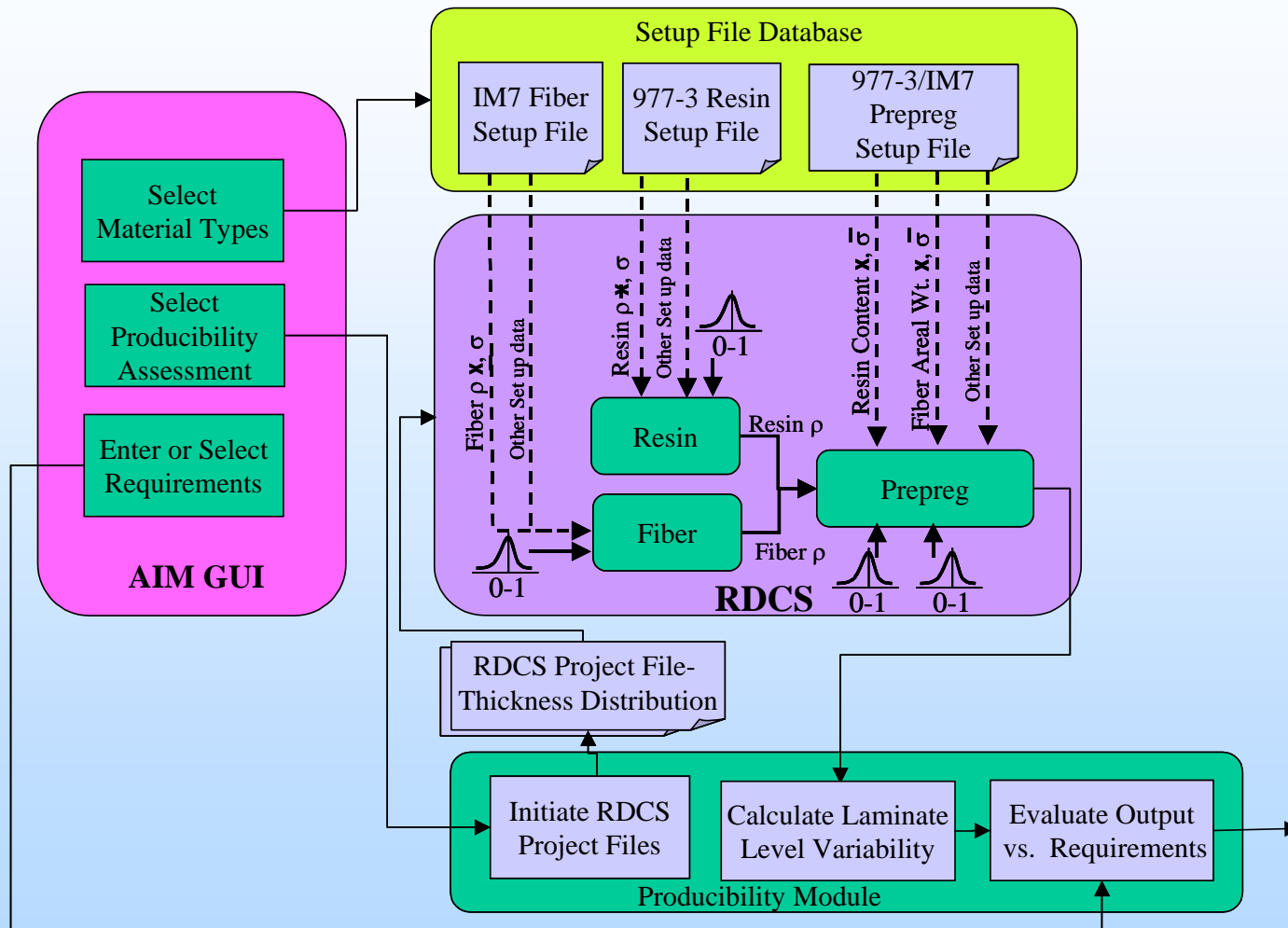



# Understanding Uncertainty – The Benefit of Linked Simulation Tools and Methodology

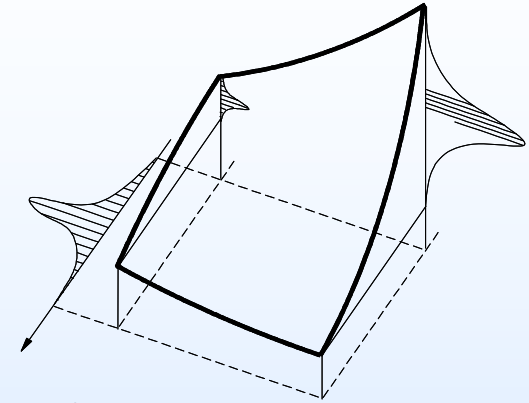

Modeling of the Process

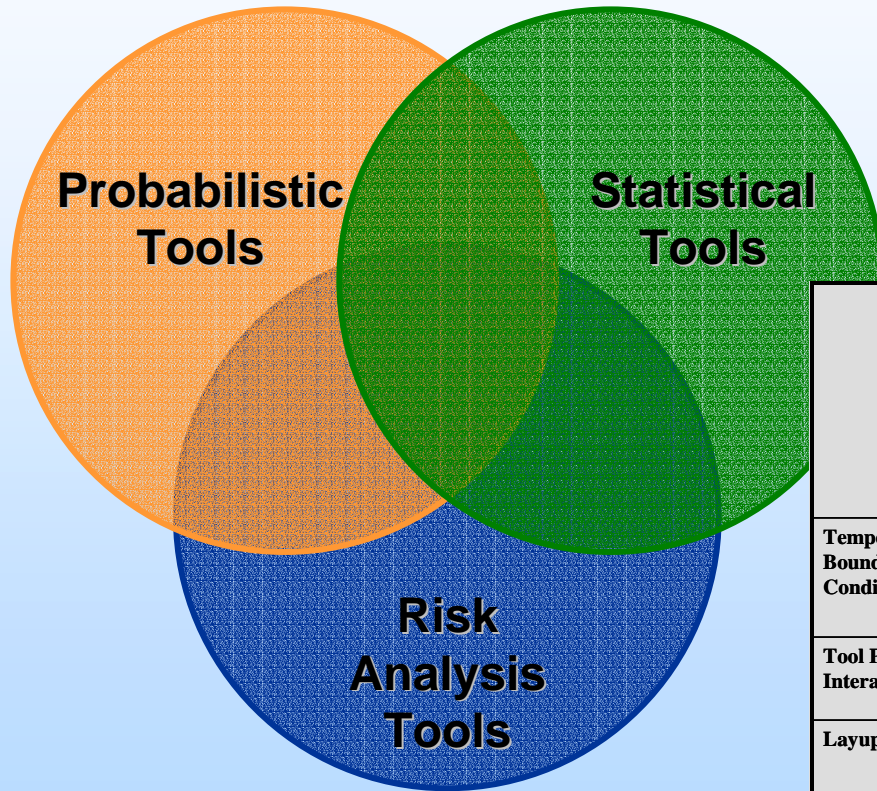

	Inherent variations associated with physical system or the environment (Aleatory uncertainty) Also known as variability, stochastic uncertainty E.G. manufacturing variations, loading environments	Uncertainty due to lack of knowledge (Epistemic uncertainty) inadequate physics models information from expert opinions.	Known Errors (acknowledged) e.g. round-off errors from machine arithmetic, mesh size errors, convergence errors, error propagation algorithm	Mistakes (unacknowledged errors) human errors e.g error in input/output, blunder in manufacturing
<b>Temperature Boundary Conditions</b>	Variation in temperature throughout an autoclave; variation in bagging thickness across part	Modeling of heat transfer coefficient of autoclave includes pressure effect but not shielding of part. Assumptions made about tool-part resistance.	Convergence of mesh must be checked. Time-steps and temperature steps must be small enough.	Errors in setup files, and other initialization procedures. Errors/bugs in code.
<b>Tool Part Interaction</b>	Part to part and point to point variations in tool finish and application of release agent	Tool-part interaction is very complex, and very local effects may at times be significant	Current model of tool-part interaction is too simple for large parts on high CTE tools.	Errors in calibrating the tool-part interaction
<b>Layup</b>	Variation in lay-up during hand or machine lay-up.	The layers are smeared within an element and it is assumed that the smeared response is representative		Error in defining layup, or alternatively errors in the manufactured part compared to model
<b>Residual Stresses</b>	Many parameters can affect residual stress: local fiber volume fraction, ...	Micro-stresses are considered to be independent of meso-stresses; there are few independent measurements of residual stress.	The formulation is believed to be most accurate when the cure cycle temperature is higher than the T <sub>g</sub> . Otherwise the residual stress calculated can be an overestimate.	Errors in material property definition, errors in coding, errors in integrating process and structural models.



# AIM-C CAT Benefits: COMPRO Integration with Robust Design Computational System (RDCS)

767-400 Raked Wingtip Front Spar  
DOE Sensitivity Analysis

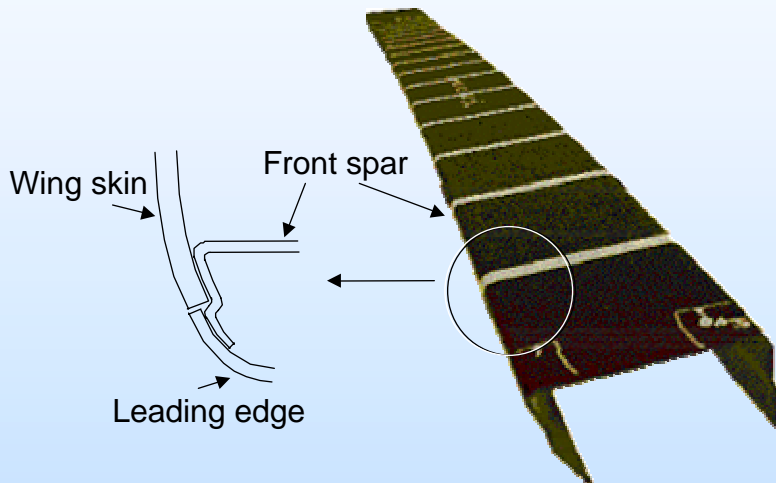

## Conventional Approach

- 32 - Runs for simple DOE
- 4 - Months calendar time to set-up and solve
- Computer (time) intense
- 216 - Hrs actual labor to complete
- Labor-intense data reduction

RDCS Sensitivity Analysis Plus  
Design Scan

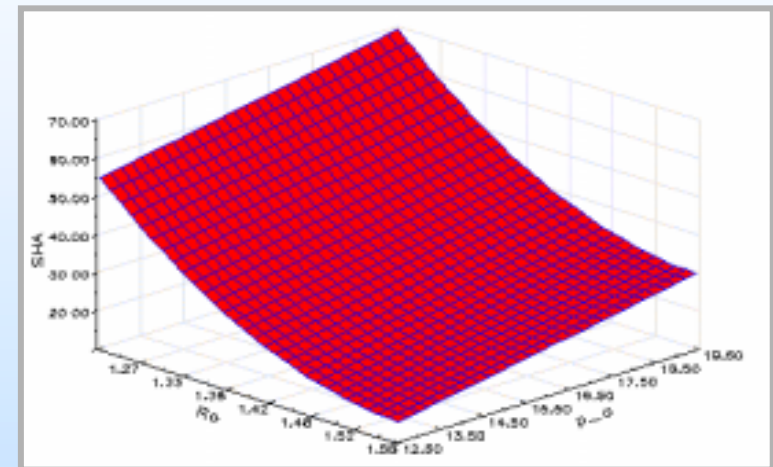

## Integrated with RDCS

- 127 - Runs for sensitivity analysis and design scan
- 1-2 weeks calendar time to set-up and solve
- User isolated from intense interaction with multiple codes
- 28 - Hrs actual labor to complete
- Automated data reduction and graphics





# Stiffener Runout Analysis Validation Tests

Variables and interactions exercised include processing effects and defects.

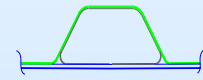
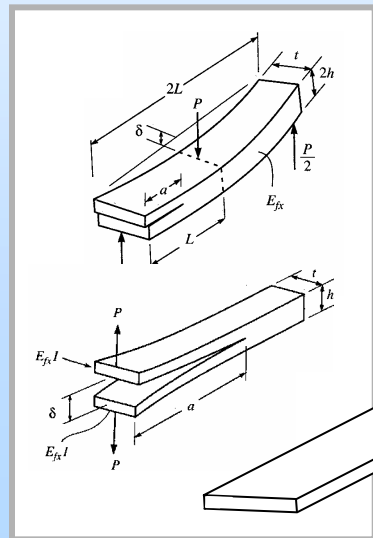

Input Data

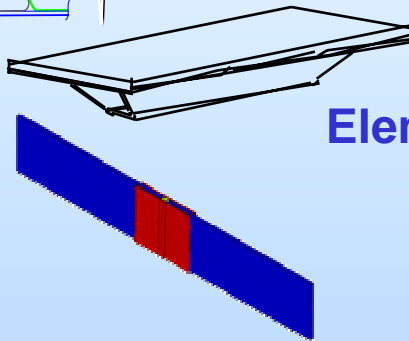

Elements

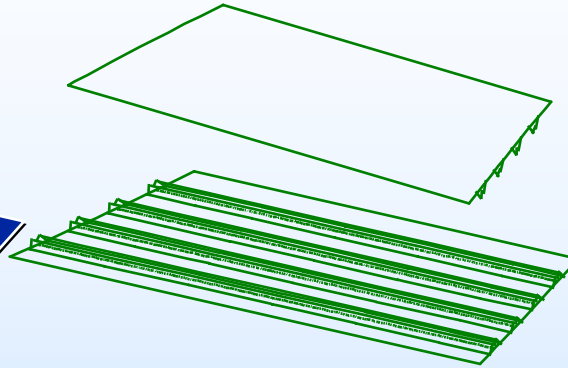

Analysis Validation Tests

- Static Strength
- Durability
- Damage Tolerance

- DCB and ENF
- $J_1$  and  $\epsilon_{eqv}$  Laminates/Joints







# Non-Symmetric Multi-Delamination Analysis

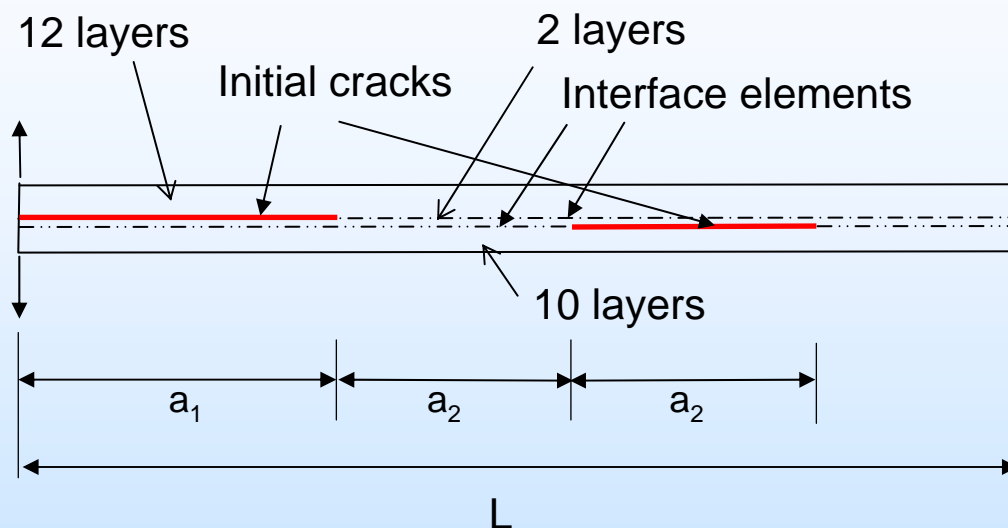

$$E_{11} = 115.0 \text{ GPa}$$

$$E_{22} = 8.5 \text{ GPa}$$

$$E_{33} = 8.5 \text{ GPa}$$

$$G_{12} = 4.5 \text{ GPa}$$

$$\nu_{12} = 0.29$$

$$\nu_{13} = 0.29$$

$$\nu_{23} = 0.3$$

$$G_{c1} = 0.33 \text{ N/mm}$$

$$G_{c2} = 0.80 \text{ N/mm}$$

$$L = 100 \text{ mm}$$

$$a_1 = 40 \text{ mm}$$

$$a_2 = 40 \text{ mm}$$

$$\text{width} = 20 \text{ mm}$$

$$\text{Layer thickness} = 0.1325 \text{ mm}$$

\*\*\* Video Demonstration \*\*\*

From Alfano and Crisfield 2001





# Non-Symmetric Multi-Delamination Comparison With Test and Analyses

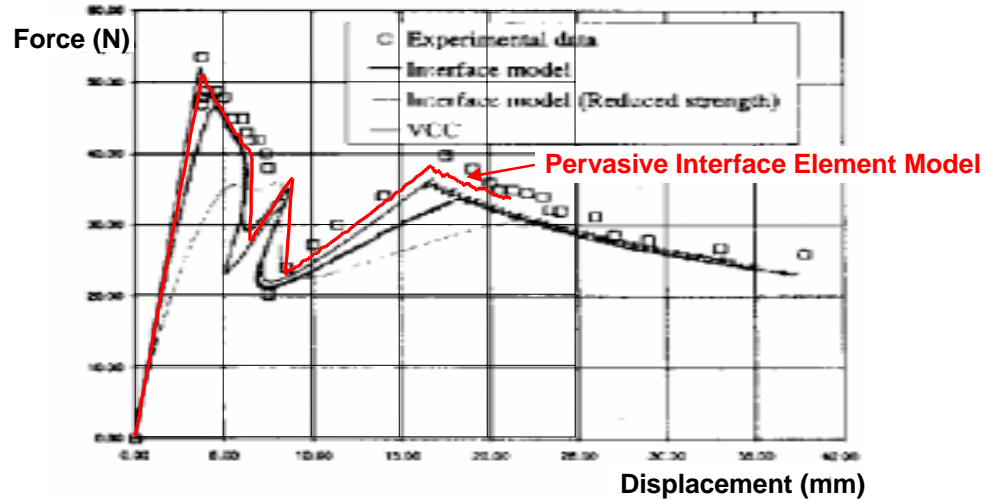

Welcome to AIM-C Program

File Edit View Go Communicator Help Yahoo!

Back Forward Reload Home Search Netscape Print Security Stop

Bookmarks Netsite: http://darpa.org/aim.navy.mil

# Accelerated Insertion of Materials

resin  $10^{-9}$  m

fiber and interface  $10^{-6}$  m

lamina  $10^3$  m

laminate  $10^{-2}$  m

structure 1 m

assembly  $10^{+2}$  m

Methodology

Process

New Features

Constituents to Component in the Shortest Time at Acceptable Risk

Edit Existing File Compute Results Save & Close

DARPA TEAM

AIM-C

BOEING



# How Will the System Be Used?

NAVAIR



## Web-Driven

- Accessed via Internet
- Used via Internet
- Application file local
- DOME enabled
- Modules available anywhere
- Configuration controlled by user
- Application file contains configuration info

*PROs most flexible*

## Web-Based

- Downloaded from Internet
- Used locally to create application file
- Application file local
- Modules & S/W available few locations
- Configuration controlled by application file
- DOME enables remote access to modules

*PROs most controlled*

## Stand Alone

- Accessed locally
- Used locally to create application file
- Application file local
- Modules & S/W available locally
- Configuration controlled by application file

*PROs may be only way for classified programs to use AIM-C*



# Knowing in part may make a fine tale, but wisdom comes from seeing the whole.\*

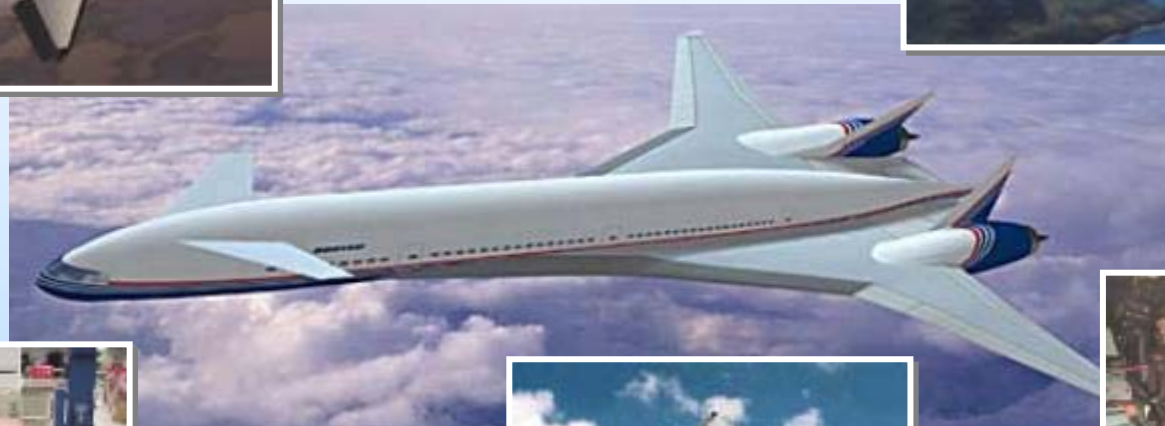
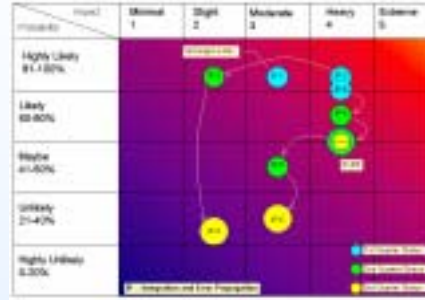

\* *Seven Blind Mice*  
by Ed Young

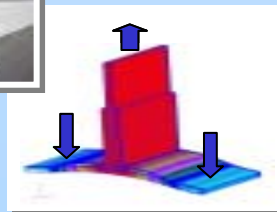

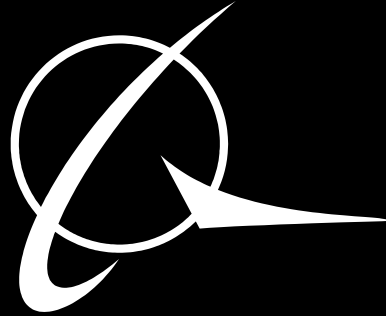

***BOEING***®