

AN ON-SITE DEMILITARIZATION CONTAINER FOR UNEXPLODED ORDNANCE

Joseph M. Serena III, P.E
US Army Engineering and Support Center, Huntsville
US Army Corps of Engineers
Huntsville, Alabama

27th Department of Defense Explosives Safety Seminar
20-22 August 1996
Las Vegas, Nevada

ABSTRACT

The Huntsville Engineering and Support Center, US Army Corps of Engineers, is the Corps' Mandatory Center of Expertise for Ordnance and Explosive Waste. The Huntsville Center is actively involved in the removal of unexploded weapons from active military installations, installations slated for closure, and formerly used defense sites. At many of these sites, ordnance has been discovered very close to schools, homes, and other inhabited and privately owned facilities. The removal of ordnance presents some hazards from the effects of an explosion, including blast overpressures and fragment projectiles. Both people and their property must be protected from these effects. Currently, all munitions must be buried before on-site detonation, or transported to a remote site for demolition.

Huntsville Center has developed a containment structure for use in on-site demolition of unexploded ordnance. This structure is designed to contain the effects of the explosion and limit evacuation to a very small work area. The container uses innovative materials for the containment of fragments and reduction of overpressures. The container will permit on-site detonation of ordnance much more safely and efficiently.

This paper presents the work involved in developing, fabricating, and proof testing the on-site demolition container. Analysis and design techniques are presented. Testing of innovative blast and fragment mitigating materials, and concept proof testing of the container, are discussed. The details of the final containment structure and limitations for its use are presented. A more detailed discussion of the development test program will be presented in a second paper immediately following this presentation.

Introduction

The Huntsville Engineering and Support Center, US Army Corps of Engineers, is the Corps' Mandatory Center of Expertise for Ordnance and Explosive Waste (OEW). In this role, the Huntsville Center defines Army and DOD policy for the remediation of sites contaminated with unexploded ordnance. The Center is also the central manager for the cleanup of more than 2,000 OEW-contaminated sites. These include active military bases under the Installation Restoration Program, formerly-used defense sites (FUDS) under the

Report Documentation Page

Form Approved
OMB No. 0704-0188

Public reporting burden for the collection of information is estimated to average 1 hour per response, including the time for reviewing instructions, searching existing data sources, gathering and maintaining the data needed, and completing and reviewing the collection of information. Send comments regarding this burden estimate or any other aspect of this collection of information, including suggestions for reducing this burden, to Washington Headquarters Services, Directorate for Information Operations and Reports, 1215 Jefferson Davis Highway, Suite 1204, Arlington VA 22202-4302. Respondents should be aware that notwithstanding any other provision of law, no person shall be subject to a penalty for failing to comply with a collection of information if it does not display a currently valid OMB control number.

1. REPORT DATE AUG 1996	2. REPORT TYPE	3. DATES COVERED 00-00-1996 to 00-00-1996			
4. TITLE AND SUBTITLE An On-Site Demilitarization Container for Unexploded Ordnance		5a. CONTRACT NUMBER			
		5b. GRANT NUMBER			
		5c. PROGRAM ELEMENT NUMBER			
6. AUTHOR(S)		5d. PROJECT NUMBER			
		5e. TASK NUMBER			
		5f. WORK UNIT NUMBER			
7. PERFORMING ORGANIZATION NAME(S) AND ADDRESS(ES) U.S. Army Corps of Engineers, Army Engineering and Support Center, Huntsville, PO Box 1600, Huntsville, AL, 35807-4301		8. PERFORMING ORGANIZATION REPORT NUMBER			
9. SPONSORING/MONITORING AGENCY NAME(S) AND ADDRESS(ES)		10. SPONSOR/MONITOR'S ACRONYM(S)			
		11. SPONSOR/MONITOR'S REPORT NUMBER(S)			
12. DISTRIBUTION/AVAILABILITY STATEMENT Approved for public release; distribution unlimited					
13. SUPPLEMENTARY NOTES See also ADM000767. Proceedings of the Twenty-Seventh DoD Explosives Safety Seminar Held in Las Vegas, NV on 22-26 August 1996.					
14. ABSTRACT see report					
15. SUBJECT TERMS					
16. SECURITY CLASSIFICATION OF:			17. LIMITATION OF ABSTRACT Same as Report (SAR)	18. NUMBER OF PAGES 10	19a. NAME OF RESPONSIBLE PERSON
a. REPORT unclassified	b. ABSTRACT unclassified	c. THIS PAGE unclassified			

Defense Environmental Restoration Program, and sites slated for closure by the Base Realignment and Closure process.

There are basically two methods for demilitarization, or destruction, of conventional ordnance at a contaminated site. If a weapon cannot be rendered safe, in situ detonation is performed. An explosive charge or penetrator is placed in contact with the munition and the round is detonated. Sandbags or earth tamping are placed over the round to reduce blast pressures and capture fragments. Munitions that can be rendered safe are usually recovered from the site and placed in temporary storage, and ultimately transported to a remote site for disposal. However, sometimes neither of these options is practical. For example, ordnance items that are found very close to a building sometimes cannot be sandbagged and detonated, because the resulting explosion may cause damage that is unacceptable to the owner. At the same time, any ordnance items that are found in the armed state must be detonated in the same position in which they are found, so moving them is not possible. Similarly, it may not be possible to move ordnance located in a congested, urban area to a remote site because private landowners or municipalities may not permit transportation of the ordnance. An additional factor to consider is the possibility of the restriction of open detonation by the Environmental Protection Agency (EPA). Already, the EPA has prohibited open burning for destroying propellants, because of the adverse effects on the environment. It is possible that the EPA may also place some restrictions on open detonation.

Consequently, the Huntsville Center has developed a containment structure for on-site demolition of ordnance. This container was designed to be a portable device, easily used in the field, that would fully contain overpressure and fragment hazards, or limit those hazards to a very small area immediately around the container. This container will permit on-site detonation of ordnance in cases where open detonation is not possible. This paper summarizes the design and development of the container.

Design, fabrication, and testing were performed by the Protective Structures Section, Structural Systems and Technology Division, of Southwest Research Institute, in San Antonio, TX.

Container Design Criteria

The specific design criteria for the container were as follows:

- Total design charge weight of at least 5 pounds equivalent weight of TNT.
- Overall exterior dimensions on the order of three to four feet.
- An exterior shell designed to be reusable for a large number of demolition shots.
- The container would be mountable on a trailer for easy transportation.
- The container was to use a fragment mitigating material, inside the outer shell, to capture fragments. This material was to be effective in capturing all fragments equal to or smaller than the 75% probable design fragment from the design munition, as defined by the Gurney and Mott equations (Department of the Army 1990).
- The overall container was to be effective in capturing all fragments equal to or smaller than the 99% probable design fragment from the design munition.

- A pressure mitigating material would be used inside the container to reduce shock and quasistatic pressures and permit a more economical, lightweight design.
- Reduction of external shock overpressures to less than 1.0 psi at a distance of 25 feet, and less than 147 decibels, or 0.014 psi, at a distance of 75 feet.

Design of the container was performed using a group of design munitions (Table 1) rather than a single design weapon. The container was designed for detonation of more than one round in each shot, with a total explosive weight of the rounds and the initiating charge as close as possible to the 5 pound limit. For fragment design, the critical munition was the M43A1 81-mm HE mortar round. The munition used for testing was the M306A1 57-mm HE recoilless rifle round.

Container Design Concept and Details

The concept design for the container (Oswald 1994) is shown in Figure 1. The concept container consists of an outer cylindrical steel shell with semi-elliptical steel end caps. The bottom cap is welded to the cylinder. The top cap is held in place by a ring clamp, C-shaped in cross section, fitted around flanges on the cylinder and top cap. The cylinder is 42 inches in diameter by 46 inches tall. Fragment mats are provided all around the outer cylinder, and at the top and bottom to protect the end caps. Two candidate fragment mat materials were identified. One was a steel cable blasting mat, which is manufactured by weaving together steel wire rope strands. The other was a rubber blasting mat, consisting of stacked, 4.5-inch wide strips of recycled tire tread, bound together with a thin steel cable. The pressure mitigating material is placed inside the fragment mats, packed around the munitions. Two candidate pressure mitigation materials were selected. One material was water, in plastic bags or balloons, placed to surround the munitions to be detonated. The other candidate material was an aqueous foam, made by a foam generating machine. While foam is less stable over time and requires the use of additional equipment at the demolition site, it had the potential of being more effective against pressures by providing water dispersed over the entire interior volume. Finally, the munitions to be detonated would be suspended at the center of the container.

Preliminary Container Design

In the preliminary analysis and design, shock and gas pressures and fragments effects inside the container were predicted. Material thickness and other details for fabrication of the test article were designed (Southwest Research Institute 1994). The solid steel shell concept and a suppressive shield concept were compared. A suppressive shield consists of an outer shell made of a series of interlocking, overlapping steel angles and channels (Huntsville Division 1977). This structure permits venting of shock and gas pressure, but eliminates any straight, line-of-sight path for fragments to escape from the container. Preliminary analysis showed that shock pressures, rather than quasistatic, or gas, pressures, would control the design. A solid steel shell would provide a much higher resistance to shock loads than a suppressive shield. The solid shell would resist the shock loads in both axial and circumferential, or "hoop," stress capacities. Conversely, the thin members of a suppressive shield would be able to resist shock loads only in bending. Also, the solid shell would be a more economical design, in both fabrication and maintenance costs. Therefore, the suppressive shield concept was discarded, and the concept of a solid outer shell was adopted.

The unmitigated shock and gas pressures were computed using the computer program BLASTX (Britt 1994). This program is designed to model rectangular and cylindrical rooms or enclosures. It computes

both shock and gas pressures and durations, based on explosive charge weight, enclosed volume, and areas of vents. It also permits the computation of internal pressures based on combustion rather than detonation.

Preliminary design was performed for a 6-pound TNT charge, which provided the usual 20-percent increase in actual charge weight for blast resistant structures, as required in TM 5-1300 (Department of the Army 1990). The container was modeled as a 42-inch diameter by 46-inch tall, flat-ended cylinder. The predicted blast pressure histories included a single, high initial peak pressure pulse and several secondary, reflected pulses. On the cylindrical wall, the initial peak pressure was 7,800 psi, with total impulse of 2,420 psi-milliseconds (psi-ms) and a duration of 3.13 ms. On the end caps, the initial peak pressure was 6,200 psi, with total impulse of 1,900 psi-ms and a duration of 1.0 ms. The predicted quasistatic (or gas) pressure was 150 psi. The design of the cylindrical shell was performed using a single degree of freedom response model. Design of the end caps was performed using the finite element program RASNA. A ductility ratio of 1.5 was assumed. That is, the steel shell was designed so the ratio of predicted stresses to allowable stresses was 1.5. Given the conservatism in predicted pressures, and the fact that unmitigated pressures were used for design, it was believed that the actual outer shell resulting from this design would actually remain elastic. This would permit the use of the shell for a large, perhaps nearly unlimited, number of demolition shots. Preliminary design of the shell resulted in a cylinder thickness of 1.375 inches, and a thickness of 2.0 inches for the end caps.

Proof of Concept Tests

Several series of tests were performed to validate both the concept and the container design, and to refine the details of the container. These included fragmentation tests, to evaluate fragment mitigating materials. Arena tests were performed to confirm the fragmenting characteristics of the design/test munition. A set of tests of explosives with water were carried out, to evaluate the shock and gas pressure mitigation provided by the water and determine the optimum quantity of water to be used. Another set of concept tests was used to validate the selected fragment capture materials and determine optimum standoff. Finally, a proof test of the entire, final container system was performed to validate the complete system. The test program is discussed in detail in a companion paper in these proceedings, (Marchand 1996). The test program will also be briefly summarized below.

Fragmentation Tests

A series of gun tests was performed to evaluate the fragment resisting performance of the two candidate materials. These tests used a 30-mm smooth bore, powder fired gun to fire test fragments, encased in a separating sabot, at sample targets of the steel and rubber mats. The design fragment selected was the worst case fragment predicted by the Gurney and Mott equations (Department of the Army 1990) for the M43A1 81-mm mortar round. The 95% probable fragment was a rough cylinder, 0.29-inch long and 0.26 inch in diameter, weighing 0.10 ounces (48 grains). The 75% probable fragment was 0.17-inch long, 0.185-inch in diameter, weighing 0.02 ounces (9.6 grains). The maximum Gurney velocity of 5900 feet per second (fps) was used for both fragments.

Due to problems with sabot design, only some test shots resulted in an effective strike of the test fragment against the mat materials. Two test shots were significant. In one test of the steel mat, the fragment struck a single front layer cable, fracturing all of the wires in that cable. The fragment damaged one strand of the cable in the rear layer, and did not strike the velocity screens behind the mat. In one test of the rubber mat, the test fragment struck and perforated completely through the rubber mat. This fragment was deflected to a very high angle, causing it to miss the rear velocity screens, but residual velocity was estimated to be less than 300 fps. Based on these tests, the steel mat was selected as the most promising material.

Arena Tests of 57-mm Munitions

Arena tests were performed using the M306A1 57-mm recoilless rifle round. The purpose of these tests was to establish fragment velocities and masses from the munition, for validation of the fragment mitigation design. The tests were also used to measure the reduced airblast caused by the munition, compared with an equivalent bare explosive charge, to confirm overpressure design. Additionally, the tests subjected the fragment mat materials to the density of fragments created by the 57-mm munition and provided additional data on which to base fragment material selection.

Four arena tests were performed. The arena tests showed that the energy absorbed by the munition case resulted in a 23% reduction in overpressure, and a 50% reduction in impulse, compared with the equivalent bare charge. This reduced the effective charge weight of the 57-mm munition from 0.55 pound of Composition B to 0.31 pound. The actual masses of fragments from the sides and base of the munition compared favorably with the predicted values. Clearly, the Mott equation predicts excessively high masses of fragments for very high confidence levels, which was expected. This result confirmed the validity of container design based on the 95% fragment. The measured velocities compared well with the velocities predicted by the Gurney equation. The maximum Gurney velocity for fragments was shown to be very conservative.

One arena test was used to evaluate fragment penetration through the steel mat and rubber mat materials. Steel witness panels were placed behind the mats to identify any fragments passing through the mats. The rubber mat allowed penetration of fragments to occur directly opposite the charge, but for larger angles of incidence, no fragment penetration occurred. No fragments passed directly through the steel cables in the blasting mat. However, some fragments passed through the openings between the cables. These fragments were traveling at an upward angle, relative to the perpendicular to the mat. The detonation of the 57-mm munition was initiated from the bottom end of the round. As the detonation wave passed upward through the charge, it caused the fragments to be thrown upward as well as outward. This affected the concept design of the container. Some method would be required to stop fragments with a vertical velocity component from passing through the mat and striking the outer shell.

Concept Test Series 1

The first series of concept tests were performed to verify the pressure attenuating performance of the water bags and the steel blast mat. The tests also verified the predicted structural response of the cylindrical shell of the container.

Typically, the unmitigated blast pressure history on the cylinder wall, nearest the charge, was a single large pressure pulse followed by numerous low amplitude reflections. The pressure history at the center of the top end plate consisted, predictably, of three high amplitude pulses: one directly from the charge, a second pulse reflected from the cylinder, and a third pulse reflected from the bottom plate. The water bags are very effective in reducing the peak quasistatic pressures and shock impulse. The arrival time of the peak pressures is also slowed significantly by the presence of the water. However, the water bags apparently induced some directionality in the peak shock pressures inside the container. The water bags were arranged differently for each test, and it was determined that this arrangement affected the pressures. Apparently, small gaps between water bags can provide a focusing effect. The initial blast wave reflects off the water and is focused through the gaps, causing high localized pressures. In the final container, arranging water around the explosives as uniformly as possible will be important. In all cases, blast pressures measured in the test container, using the water bags and blasting mats, are much less than those from a bare explosive, and much less than the pressure histories used for preliminary design of the container.

The combined action of the water bags and the steel blast mats significantly affected shock pressures. The mats were very effective at reducing the peak incident pressures and impulses. The mat also nearly eliminated the reflected pulses. This effect is not surprising, because the geometry of the mats causes them to act as a suppressive shield. The mat partially confines the initial pressure pulse and allows it to vent into the space between the mat and the outer shell of the container.

This series of tests also provided important data on the performance of the steel cable blast mats. For very small standoff distances, at or less than 1 foot, the mats suffered significant damage. In these tests, at least a dozen strands¹ were broken in the cylindrical mat at the point closest to the charge. For standoffs of 1.5 feet, however, the damage was significantly less, with only a few individual wires broken in a few strands. This data led to the use of a cylindrical cable mat with as large an inner diameter as possible inside the container shell. The inside diameter of the mat was increased from 24 inches to 36 inches, and the individual cable diameter was increased from 0.625 inch to 0.75 inch.

Concept Test Series 2

The second series of concept tests was performed to evaluate the fragment mitigation effects of the steel blasting mats. Several configurations of steel mats were tested. In one test, a pair of mats were used. The outer mat was constructed with the cables oriented in the hoop direction, and the inner mat was made with cables in the vertical, or longitudinal, direction. This dual mat concept was believed to be a good method of intercepting all fragments. Actual 57-mm munitions were used as the donor. Again, we observed severe damage to the inner mat, because of the small standoff between the mat and the munitions. At the closest points, virtually all cable strands in the inner mat were broken. The primary cause of this damage was blast pressure. Also, since the cables were oriented vertically, there was no hoop stress resistance available in these cables.

The damage to the inner cylindrical mat was judged to be unacceptable. Clearly, such extreme damage would require replacing the inner mat for every shot, which is expensive and impractical. Instead, several alternate methods of capturing fragments, before they reach the outer shell, were considered. After weighing several options, it was decided use a single layer of cable mats, with strands in the hoop orientation, and to place another layer of steel between the outer shell and the mats. This layer would capture any lower velocity fragments that penetrate the blast mats. Evaluation of fragment masses and velocities led to a design thickness of 0.5 inch for this steel liner. This idea was tested. Damage to the cable mat was still significant, with 2-inch to 3-inch lengths of steel strands that were essentially shredded by the fragments. The steel liner suffered approximately 50 significant penetrations, with a maximum depth of about 3/8 inch. Given these results, it was determined that an additional method was needed to slow the fragments before they reached the steel blasting mats. Rather than add another reusable layer of material, the concept chosen was to surround the munition with sand, providing 6 to 9 inches of sand all around the munition. Tests showed that the sand was quite effective in reducing damage to the steel blast mats. Typically only one or two strands were broken in the cylindrical mat in each test. Few fragments struck 0.5-inch steel liner plate, and maximum penetration depth into this liner was only about 1/16 inch.

Final Container Design

¹A note about terminology: The steel blasting mat is woven out of cables. Each cable is made up of several strands twisted together. Each strand consists of a large number of wires.

The final container design is shown in Figure 2. The outer shell of the container is a steel cylinder, with a 42-inch inside diameter, 1.375 inches thick and 42 inches tall. The top and bottom are semi-elliptical steel end caps with a thickness of 1.5 inches. The bottom end cap is welded to the steel cylinder. Four 1-inch diameter vent holes are provided in the bottom end cap to provide venting. The top end cap is clamped to the cylinder with a steel ring clamp, nominally 2.0 inches thick. This clamp is manufactured in two halves, which are joined together in a hinge attached to the cylinder. These two halves can open and close in a scissor motion. In the closed position, the halves are joined by a pair of 2-inch diameter bolts. This arrangement is very effective in connecting the top end cap to the cylinder. All pressures that would tend to blow the cap off the cylinder are resisted in shear by the ring clamp. The gas pressure against the clamp, caused as gases vent through the gap between the top and the cylinder, are resisted in tension by the bolts. A 4-inch diameter, flanged drain and washout port is provided in the bottom end cap. A removable cover plate is bolted to the outer flange.

Inside the cylinder is a steel liner plate, 0.5-inch thick, made in four removable segments, to provide final capture for fragments. Inside the steel plate liner is a cylindrical steel cable blasting mat, with a 36-inch inside diameter, 36 inches tall, with principal cables woven in the hoop direction, and a cable diameter of 0.75 inch. The top and bottom end caps are protected from fragments using a flat, 0.5-inch thick plate, and two flat layers of steel cable blasting mats. The munitions to be detonated will be suspended at the center of the container and surrounded by a cylinder of sand, encased in a cardboard or plastic tube, that provides at least 6 inches of sand cover over the munitions. Water bags will be placed between the sand and the steel mat, using a water to explosive weight ratio of 5:1. (Water bags are not shown in Figure 2.)

The entire container is mounted on a steel frame, as shown in Figure 3. The frame includes an elevated walkway, made of fiberglass grating, all around the container to provide a working platform. A jib-crane boom and chain hoist are provided on the frame to permit removal of the top end cap. The entire container and frame assembly weighs about 10,000 pounds, and can be mounted on a trailer. The steel cable mats and liner plates will be replaced as necessary. It is anticipated that the steel mats will be usable for five to ten shots, and the steel liner plates for at least 15 shots.

Conclusions

At this writing, all design and testing for the container have been completed. The fabrication of the final container is complete. The container was subjected to a proof test, using all fragment and blast mitigating materials. The donor charge for the proof test consisted of three M306A1 rounds, plus enough C-4 explosive to provide a total explosive weight equivalent to 6 pounds of TNT. After the donor was detonated, the container was carefully inspected. The steel cable mats suffered only moderate damage from fragments, and no other damage occurred. The container captured all fragments and blast overpressures. Noise levels outside the container, during the venting of explosion products, was only 105 dB at a distance of 75 feet. The proof test completely validated the use of the container for the design charge weight and munitions. The next step is to obtain DDESB approval for use of the container. Once this approval is obtained, the container will be deployed for use at an ordnance remediation site. Data on the performance of the fragment mitigation system will be collected, in order to develop guidelines for replacement of materials, refine operational procedures, and determine the actual time and costs of using the container.

This container is only the first is what is hoped will be a series of on-site demolition containers and devices. If the method proves to be practical in the field, the construction of other containers is planned. Other containers will provide for demolition of more and/or larger munitions. These will be either existing explosives containers modified to resist fragments, or completely new designs. As this development effort continues, other innovative materials for reducing blast and fragment effects will be evaluated.

References

Britt, J. R., and M. G. Lumsden, 1994. "Internal Blast and Thermal Environment From Internal and External Explosions: BLASTX Code, Version 3.0," Science Applications International Corporation, San Diego, CA.

Departments of the Army, Navy and Air Force, 1990. Structures to Resist the Effects of Accidental Explosions, TM5-1300/NAVFAC P-397/AFR 88-22, Washington, DC.

Marchand, K. A., C. J. Oswald & M. A. Polcyn, 1996. "Testing and Analysis Done in Support of the Development of a Container for On-Site Weapon Demilitarization," 27th Department of Defense Explosives Safety Seminar, Las Vegas, NV, 20-22 August 1994.

Oswald, C. J., 1994. "Preliminary Design of Container for On-Site Munition Demolition," Southwest Research Institute, San Antonio, TX, 11 November 1994.

Southwest Research Institute, "Preliminary Design Calculations for On-Site Demolition Container," San Antonio, TX, 11 November 1994.

Huntsville Division 1977. Suppressive Shields Structural Design and Analysis Handbook, HNDM-1110-1-2, Huntsville Division, US Army Corps of Engineers, Huntsville, AL, 18 November 1977.

Table 1. Design Munitions Group for Container

Munition	Type	Length (in)	High Explosive Weight (lb)	Total Munition Weight (lb)
57mm HE M306A1	Recoilless Rifle	17.54	0.55 Comp B	5.46
60mm HE M49A5	Mortar	14.71	0.79 Comp B	3.90
60mm HE M49A4	Mortar	11.59	0.42 Comp B	3.25
75mm HE M309A1	Recoilless Rifle	28.92	1.49 TNT	22.27
75mm HE M48	Howitzer	23.50	1.49 TNT	18.24
81mm HE M374A2	Mortar	20.84	2.10 Comp B	9.34
81mm HE M43A1	Mortar	13.32	1.29 Comp B	7.15

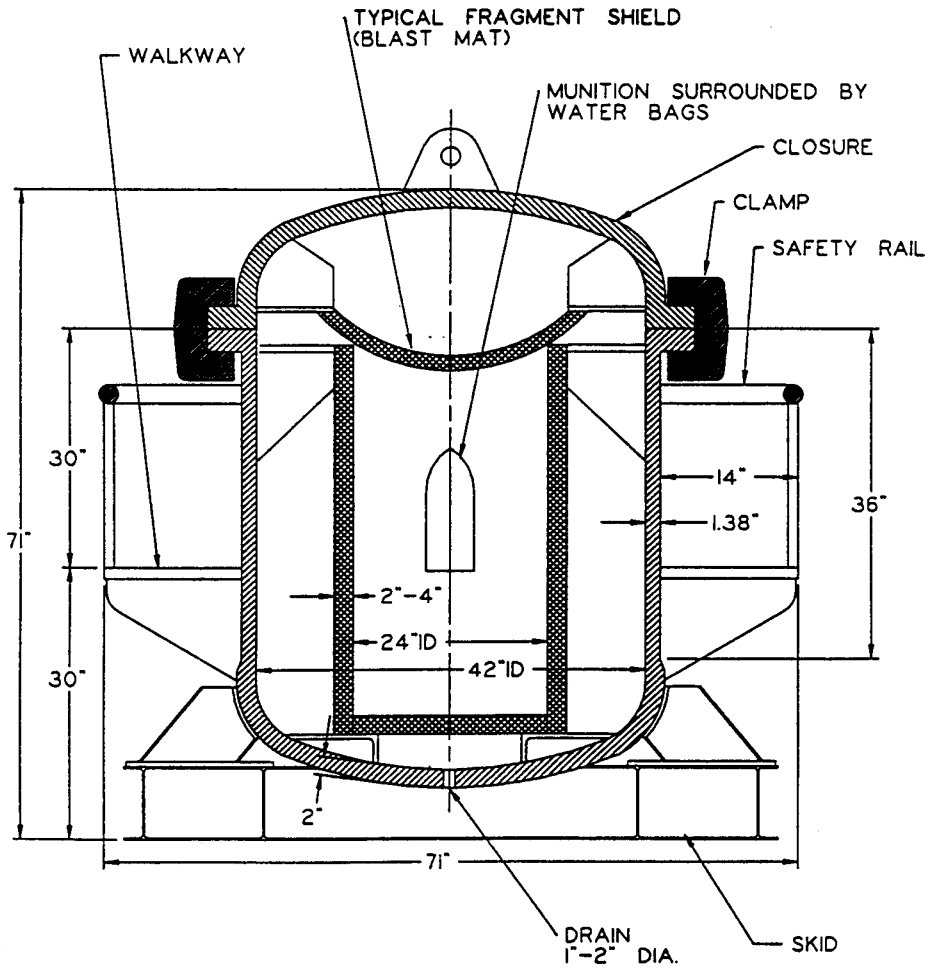

Figure 1. Container Concept Design, Section View

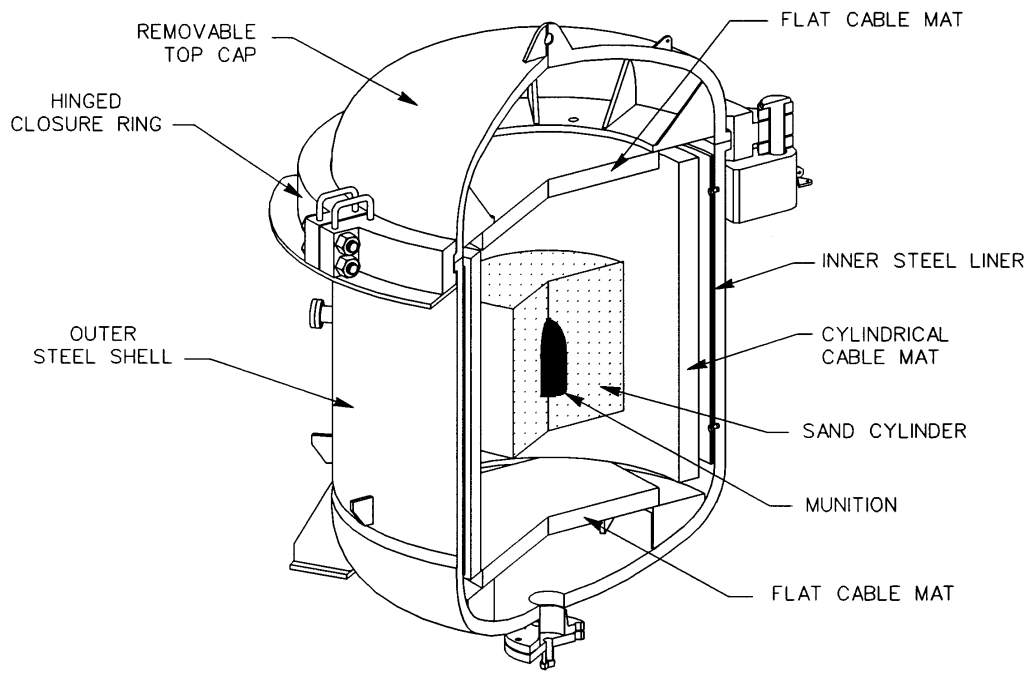

Figure 2. Final Container Design, Section View



Figure 3. Fabricated Container and Frame