

Surfzone Water Properties Sensor (SWAN)

Michael Twardowski
Department of Research
WET Labs, Inc.
165 Dean Knauss Dr.
Narragansett, RI 02882
phone: (401)783-1787 fax: (401)783-0309 email: mtwardo@wetlabs2.com

Contract Number: N0001407M0207

<http://www.wetlabs.com/>

LONG-TERM GOALS

Our long-term goal is to develop a suite of compact, inexpensive in situ optical property sensors for use on autonomous platforms. As part of this long-term goal, our Phase I research efforts have focused on design, development, and testing of an inexpensive (nominally expendable) water property measurement system to provide environmental optical parameters in the surfzone that are critical for MCM operations. Work under this Phase I SBIR has been enabled by recent technological advances, including recent development of attenuation, scattering, and backscattering sensors for AUVs and other compact platforms. A SWAN (Surfzone Water Attenuation Node) will have a newly designed sensor (the BAM3) measuring multi-spectral attenuation, c , at 470, 532, and 660 nm, as well as GPS and RF communications. SWANs will be able to operate as drifters or as moored packages and will be capable of intelligent networking. A goal is to achieve a cost factor of \$1K for the BAM3 and \$2K for the SWAN.

In Phase-II, a SWAN-x version will also be developed that will additionally have recently developed sensors measuring total scattering (AUV-B) and multi-wavelength backscattering (ECO-BB3). As a comprehensive but compact package measuring attenuation, scattering, absorption, and backscattering, with an expected product cost of \$10-15K, the SWAN-x is expected to also have commercial potential in the environmental research and monitoring markets. For Naval surfzone operations, it is envisioned that several networked SWANs could be deployed parallel to shore along with a SWAN-x providing more comprehensive optical information. Measured optical properties have direct application in constraining performance prediction models for optical MCM applications including passive hyperspectral imaging, active lidar detection, and diver visibility.

OBJECTIVES

For Phase-I of the project, the objective is to demonstrate the feasibility of our approach for measuring multi-spectral beam attenuation with a compact, inexpensive sensor. The key innovation is making a good quality measurement at low cost. Our ultimate objective is to develop commercially viable SWAN and SWAN-x products as low-weight/power/cost sensing tools for a wide variety of autonomous military, research, and low-budget monitoring applications.

Report Documentation Page

Form Approved
OMB No. 0704-0188

Public reporting burden for the collection of information is estimated to average 1 hour per response, including the time for reviewing instructions, searching existing data sources, gathering and maintaining the data needed, and completing and reviewing the collection of information. Send comments regarding this burden estimate or any other aspect of this collection of information, including suggestions for reducing this burden, to Washington Headquarters Services, Directorate for Information Operations and Reports, 1215 Jefferson Davis Highway, Suite 1204, Arlington VA 22202-4302. Respondents should be aware that notwithstanding any other provision of law, no person shall be subject to a penalty for failing to comply with a collection of information if it does not display a currently valid OMB control number.

1. REPORT DATE 2007		2. REPORT TYPE		3. DATES COVERED 00-00-2007 to 00-00-2007	
4. TITLE AND SUBTITLE Surfzone Water Properties Sensor (SWAN)				5a. CONTRACT NUMBER	
				5b. GRANT NUMBER	
				5c. PROGRAM ELEMENT NUMBER	
6. AUTHOR(S)				5d. PROJECT NUMBER	
				5e. TASK NUMBER	
				5f. WORK UNIT NUMBER	
7. PERFORMING ORGANIZATION NAME(S) AND ADDRESS(ES) WET Labs, Inc, Department of Research, 165 Dean Knauss Dr., Narragansett, RI, 02882				8. PERFORMING ORGANIZATION REPORT NUMBER	
9. SPONSORING/MONITORING AGENCY NAME(S) AND ADDRESS(ES)				10. SPONSOR/MONITOR'S ACRONYM(S)	
				11. SPONSOR/MONITOR'S REPORT NUMBER(S)	
12. DISTRIBUTION/AVAILABILITY STATEMENT Approved for public release; distribution unlimited					
13. SUPPLEMENTARY NOTES					
14. ABSTRACT					
15. SUBJECT TERMS					
16. SECURITY CLASSIFICATION OF:			17. LIMITATION OF ABSTRACT	18. NUMBER OF PAGES	19a. NAME OF RESPONSIBLE PERSON
a. REPORT unclassified	b. ABSTRACT unclassified	c. THIS PAGE unclassified			

APPROACH

Optically based methods for Mine Counter Measures (MCM) include passive detection with hyperspectral imaging spectrometers, active detection with lidar platforms, and direct human diver sighting. Environmental optical conditions reconnaissance before deployment of these assets can be used to predict and optimize asset performance. For active systems, performance prediction usually involves estimating a Probability of Detection (PD) or Probability of Identification (PID) as a function of operational parameters such as platform towing altitude above the bottom. Performance optimization for these assets could range from adjusting operational parameters to optimize chances of detection to helping determine the most effective asset for a given set of conditions or making the determination that any asset deployment would be ineffective.

In the surfzone (< 3 m depth to the shoreline), passive detection methods have advantages because towed platforms often are not practical in very shallow water and low flying assets such as helicopters towing close to shore may be exposed to enemy fire. Hyperspectral imagers may be flown at safer altitudes using Unmanned Aerial Vehicle (UAV) drones. Deployment of divers is undesirable for such high risk operations. Since active lidar systems and divers may nonetheless have roles in surfzone MCM in some circumstances now and in the future, these methods are also considered.

For 1) predicting the depth to which we may “see” the bottom and differentiate contrast between different bottom types in passive imaging applications, 2) constraining parameters in lidar applications, and 3) predicting diver visibility, the optical parameter of critical importance is beam attenuation, c . As such, a focus of this project is developing an attenuation device suited for surfzone deployment on a compact platform. Design criteria for this sensor include low cost (<\$2K), low power, compact, and multi-spectral resolution. The sensor will be incorporated into a robust deployment package called a Surfzone Water Attenuation Node (SWAN), which will include GPS and wireless communications with networking capabilities.

An illustration of the concept for the beam attenuation meter, termed the BAM, is shown in **Fig. 1**. The attenuation measurement incorporates a source assembly with a dichroic prism fed by three separate light-emitting diodes ($\lambda = 470$ nm, 532 nm, and 660 nm). The dichroic prism is designed to allow transmission of each of the sources via dichroic reflection for the blue and red LEDs and band-pass transmission for the green LED (**Fig. 2**). This is the same technology currently used in LED projection televisions. As a result of this large-volume application, dichroic prisms are now inexpensive (<\$50 in some cases) and available in a variety of sizes and spectral properties. We believe this design is the key to a simple but elegant solution for an inexpensive multi-spectral c meter. The optical, electronic, and mechanical components are cheap, and the design would lend itself to snap-together assembly. The BAM would be suitable for incorporation into a variety of platforms for sampling the surfzone and other marine and freshwater environments. Because of the inexpensive cost and the direct application of beam attenuation measurements in biogeochemical and environmental studies, we believe this sensor would allow WET Labs to access completely new markets such as low budget environmental sampling/monitoring by small civil communities.

Current Phase I implementation of our concept involves fabricating and testing a bench top version of the BAM using the proposed inexpensive optical and electronic components. Relative errors in measuring attenuation with this sensor are then being assessed and directly related to resulting errors expected in image interpretations in the surfzone such as visibility, depth penetration and seafloor

property characterization. Phase-I work also is including comprehensive designs and specifications for the SWAN and SWAN-x and field experiments to assess the behavior of different surfzone drifter designs. In future Phase-II work, 3 SWANs and 1 SWAN-x will be fabricated and tested as an integrated surfzone sampling network.

WORK COMPLETED

- Bench tested single wavelength (650nm) BAM optical design and response linearity.
- Preliminary design criteria for the single wavelength, miniaturized beam attenuation meter (BAM) were developed and distributed to all engineers project work team.
- Produced an External Reference Specification (ERS) document for the single wavelength BAM
- A Bill of Materials (BOM) was assembled for the preliminary BOM design based on conceptual model and bench test results to estimate expected production costs
- Completed analysis of form factor, mass distribution, and preliminary design of the SWAN platform.
- Built and tested SWAN platform prototype.
- Assessed the effects of temperature and uncertainty errors on MCM performance

RESULTS

A bench top optical test fixture was designed and constructed utilizing reflective prisms to fold the optics. This fixture allowed initial tests of linearity and resolution using our standard red LED's (650 nm) and ECO based detection circuitry for the BAM. As a part of this test fixture, several mechanical features were added to allow for fine tuning of the optical alignment. One of the goals in progressing towards a low cost design is to understand and define the effects of optical alignment on the overall performance of the system. This will aid in design decisions that could possibly help bring down the overall cost of the system. Initial optical bench top test fixture and electronics manipulations were carried out with a series of neutral density filters inserted in the optical detection volume to modify the transmission through the system. Results showed that the response of the system is highly linear with 0.002 m⁻¹ resolution in attenuation at 650nm.

To assess errors in attenuation values with the electro-optical components we expect to use for the BAM, a mock-up was assembled with our proprietary eco-2 electronics to evaluate the suitability of this board set for the BAM measurement. This unit was run through two temperature profiles and an overnight stability test. The resulting data files were processed to evaluate how well a soft temperature correction based on the optical reference would work. The corrected temperature run values as well as stability values were then compared to pass/fail marks for a conventional attenuation device (WET Labs C-star). Results showed the eco-2 board stack is capable of meeting all of the current C-Star pass/fail marks:

- The % change in corrected signal during the temperature run was 0.38%. The pass/fail mark for a standard C-Star is 0.63% of its nominal 4.80V signal. The build goal for a standard C-Star is 0.42%.
- For the overnight stability test, the corrected signal had a total excursion of 39 out of 13750 digital counts over the 14+ hour test, working out to a % change of 0.0192% per hour. A standard C-Star has a pass/fail criteria of 0.0208% per hour.
- Short term standard deviation measurements were gathered from the overnight run. During the first minute after initial power up, the standard deviation was 1.69 out of 13750 counts, for a signal to noise ratio of 8080:1. A standard C-Star must meet a pass/fail standard deviation for signal to noise ratio of 4800:1.

To assess how these errors would impact using the BAM in MCM applications, we first considered the effect of errors in the determination of the beam attenuation coefficient (c) on the visibility range for divers. This is also closely related to bottom depth detection and bottom type discrimination capabilities for passive imaging systems. The visibility range of divers is defined as the horizontal distance over which a diver can just distinguish a 20 cm diameter black disk. Zaneveld and Pegau (2003) have studied diver visibility and its relationship to c . Their conclusion was that:

$$\text{diver visibility range} = 4.5 / [c_{pg}(532)*0.9+0.081].$$

The data that went into this determination are shown in **Fig. 3**.

We see in **Fig. 3** that the correlation between diver visibility range and c is excellent statistically, but individual data points can be up to 30% from the mean line (red). Ninety-five percent of the data fits within the +/- 20% (blue) lines. A large component of the error for individual data points is the difference in contrast perception between different human observers.

Temperature calibrations of the SWAN c -meter showed that the % change for the corrected measurement was 0.54% over a range of 2 to 37 degrees Centigrade. Note that this is for raw counts, which are proportional to transmission. The standard deviation of an overnight run was 1.69 out of 13750 counts, or 0.012%. The combined error thus is 0.55% of raw counts.

Since $\text{transmission} = \exp(-cr)$, the error translates non-linearly into a visibility range error. The error is larger for smaller c values, which result in larger visibility range errors. **Fig. 4** plots the error. The error in visibility range thus increases with decreasing beam attenuation coefficient, but does not reach 20% until the visibility is around 10 m. In the surfzone, where visibility is typically <10 m, these error estimates are within operational specifications (typically within +/-20%).

Based on these results, an initial External Reference Specification (ERS) document was produced which describes the development goals for the BAM/SWAN, defines the initial design specifications, and outlines a time line for accomplishments. The ERS is intended to be a living document, and will evolve over the lifetime of development. Based on the promising initial results of the bench top test fixture, the primary specifications of the BAM sensor was established and a set of mechanical and electronics drawings were fabricated. From these documents, we were able to produce a BAM system

level BOM. This is a critical step in assessing the cost of the BAM sensor. Results of this analysis have shown that it appears possible to manufacture a BAM/SWAN surfzone drifter product at a cost <\$2000.

The design analysis of the Surfzone Water Attenuation Node (SWAN) platform was completed. The SWAN's purpose is to act as a stable platform from which to conduct beam attenuation measurements in active surfzone environments, and in particular, avoid beaching and tumbling. In addition to serving as the sensor platform, the SWAN should also provide the power source (batteries), positional tracking (GPS), and the communications interface (wireless). Our initial preliminary design was based on an existing and successful drifter platform design (Schmidt et al. 2003). Further consideration of our initial BAM sensor designs, and our resident knowledge on GPS, data handling, and wireless communication interfaces culminated in the final design.

The SWAN platform includes a communication system, a GPS system and a data handler. Several wireless communication systems are available for use with the SWAN platform, including WiFi, FreeWave Radio Frequency, and cellular phone. WiFi is the cheapest, but range is limited and there is typically no encryption capabilities. WET Labs has experience developing data interfaces with these systems and has developed interface boards for our autonomous profiler project. We have also developed a small GPS interface board and antenna system for our autonomous moored profilers. This system is ideally suited to incorporation with the SWAN platform as it is inexpensive, compact and uses a COTS GPS system. We are currently still evaluating potential control electronics for the sensors and communications (embedded and OEM solutions such as Crossbow Stargate).

The key design parameters for the SWAN platform are drifter length, damper disk radius, antenna height effects, and overall stability as a function of center of mass, buoyancy, and weight distribution. Based on the results of this analysis and preliminary testing, a mock SWAN platform was constructed with minimal electronics to evaluate the performance of our drifter design in a surfzone environment (**Fig. 5**). The platform was built so that the various components screw together for simple assembly, easily amenable to alteration. The communications block on top of the platform rides approximately 5 cm above the water surface when deployed. With damper disk and lead shot weight centered just below the disk, the platform has a strong righting moment in wave fields. Preliminary testing has demonstrated this platform satisfies our design criteria at this time.

IMPACT/APPLICATIONS

Progress and results represent important steps toward the development of a surfzone optical sensing system measuring a , b , c , and b_b for Naval operations and oceanographic research. Knowledge of the Inherent Optical Properties of water can be used to predict and optimize the performance of a host of Naval operations that rely on divers, cameras, laser imaging systems, and active and passive remote sensing systems. These include mine countermeasures, harbor security operations, debris field mapping, anti-submarine warfare, and search and salvage operations. These measurements are also widely used in environmental monitoring and research applications for determining particle concentration, particle composition, and water clarity.

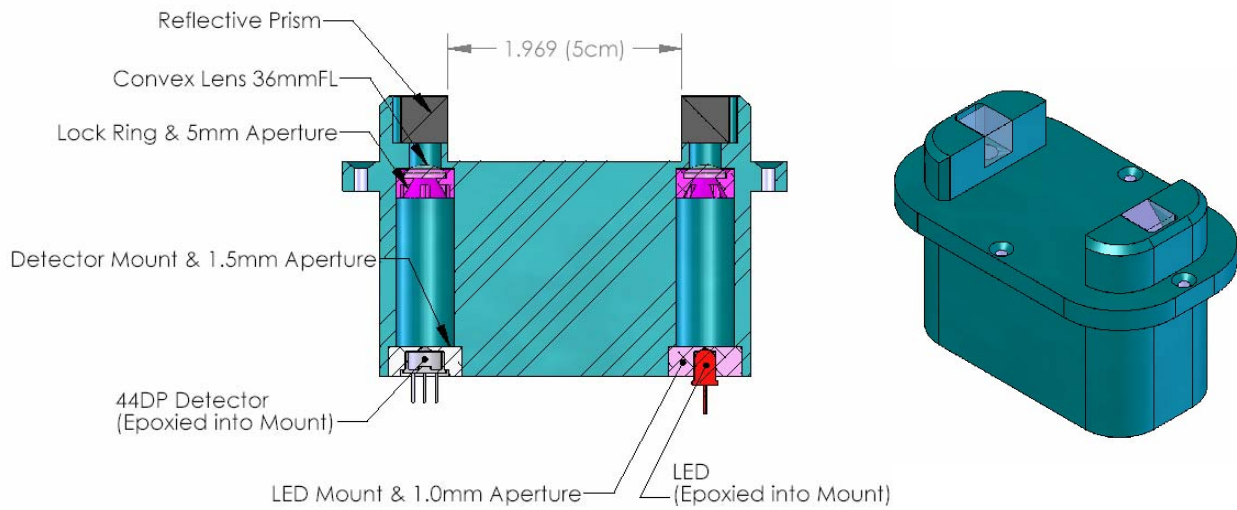

Fig. 1. Schematic for an inexpensive, low power, compact attenuation meter (BAM).

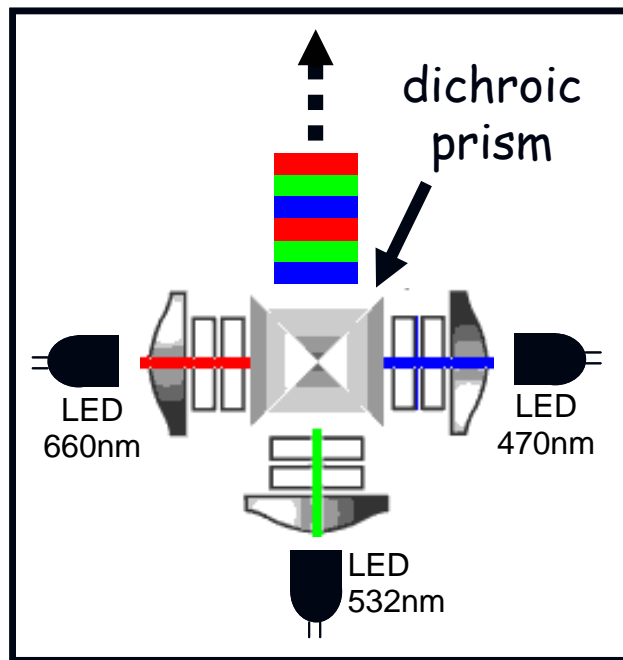

Fig. 2. Three-wavelength source assembly with dichroic prism. Orthogonal surfaces in prism selectively reflect blue or red light while transmitting green.

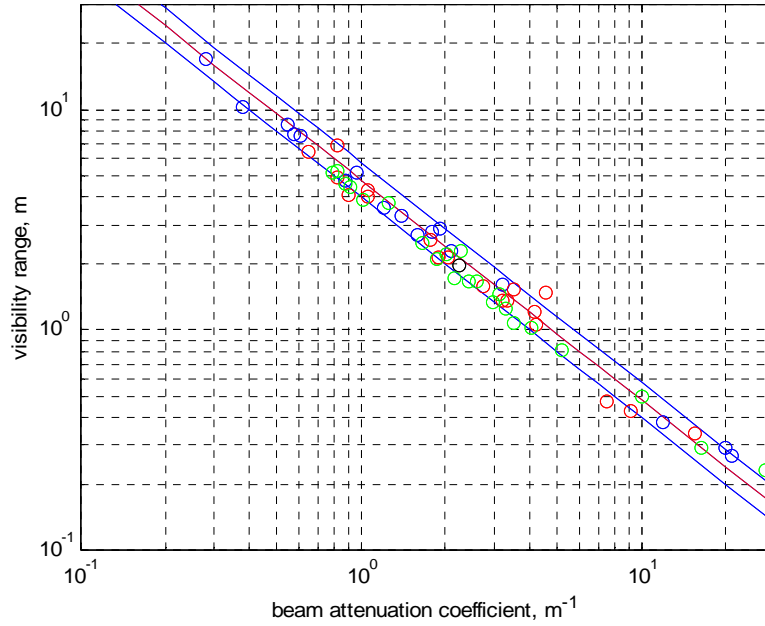

Fig. 3. Horizontal visibility of a 200 mm diameter black target. Colors of circles refer to three different observers. Red line indicates $vis. range = y = 4.5/\alpha$ and the blue lines are $\pm 20\%$ lines; $\alpha = \text{photopic attenuation coefficient} = 4.5 / [c_{pg}(532) * 0.9 + 0.081]$; $r^2 = 0.985$. (From Zaneveld and Pegau, 2003). Diver visibility ranges are also closely related to bottom depth detection and bottom type discrimination capabilities for passive imaging systems.

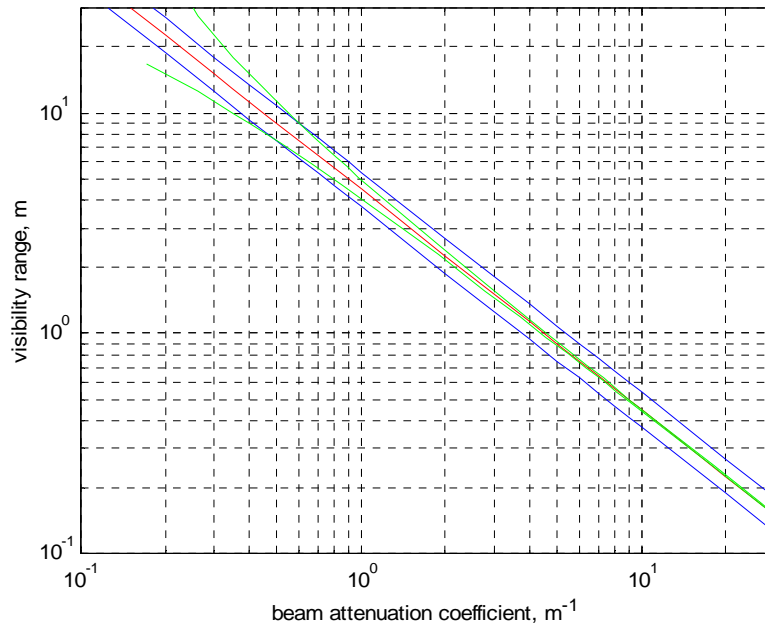

Fig. 4. Blue lines as in Fig.3. Green lines indicate error bounds due to temperature and noise in the SWAN c-meter.

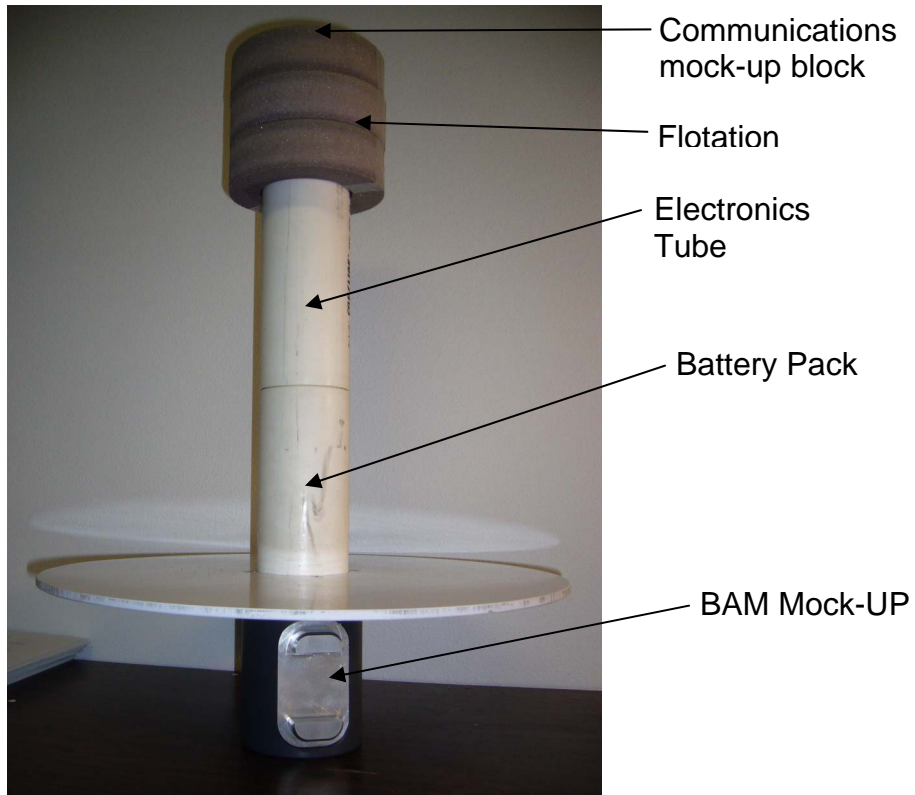

Fig. 5. Complete SWAN assembly. Communications block, flotation tube, and electronics tube screw together with o-ring seals.

TRANSITIONS

We expect that our efforts in developing optical sensors for automated deployment platforms and our success in integrating these sensors on such platforms will lead to transition of these optical sensors into operational tools for the fleet and the oceanographic research community in the future. Parent sensors to the sensors under development in this work are currently being used on automated platforms in Naval mine countermeasure exercises such as RIMPAC and in ONR research initiatives such as OASIS and RADYO. Slocum gliders equipped with these sensors are used in academic research (Rutgers University and North Carolina University), in recently delivered NRL slocum gliders, and in recently ordered Naval Oceanographic Office gliders.

RELATED PROJECTS

Miniaturizing and integrating sensing technologies for use on a host of new autonomous sampling platforms has been a major focus for WET Labs for the past few years. Several R/R&D efforts ongoing and in the recent past reflect this focus:

1. WET Labs is working in partnership with several collaborators to develop moored optical and chemical profilers for 4-D characterization of coastal waters (URI, NOPP).
2. WET Labs is working in partnership with researchers in the development of miniature attenuation sensors using a conventional transmission configuration. These sensors are to be incorporated on next generation profiling drifters (LBN Labs and SIO, ONR contract).
3. WET Labs is working in partnership with researchers to develop next generation biooptical tools for integration on Erikson Gliders (U. Maine, U. Washington, NOPP).
4. WET Labs is working in partnership with researchers to develop next generation optical tools for application in long-term moorings (UCSB, ONR contract).
5. WET Labs is funded by NASA to develop and implement miniature optical sensors for deployment on PALACE floats (Boss and Zaneveld, PIs).
6. WET Labs is funded by NASA to develop a towed, integrated optical profiling system for synoptic remote sensing validation work through a Phase-II SBIR (Twardowski, PI).
7. WET Labs is funded by ONR to develop a compact, robust, hydrodynamic attenuation meter using a novel technique compatible with a small form factor (Twardowski, PI).
8. WET Labs is funded by NASA to develop an in-situ biogeochemical sensor using excitation-emission matrix (EEM) fluorometry through a Phase-II SBIR (Moore, PI).
9. WET Labs is funded by NASA to develop an optical sensor for making robust analytical determinations of biogeochemical parameters such as TSM and POC (Twardowski, PI).

REFERENCES

Zaneveld, J.R.V. and W. Pegau. 2003. Robust underwater visibility parameter. *Optics Express*, 11(23): 2997-3009.

PUBLICATIONS

Sullivan, J.M., M.S. **Twardowski**, Donaghay, P.L., and Freeman, S.A. 2005. Using Scattering Characteristics to Discriminate Particle Types in US Coastal Waters, *Appl. Opt.*, 44:1667-1680. [refereed]

Trees, C.C., P.W. Bissett, H. Dierssen, D.D.R. Kohler, M.A. Moline, J.L. Mueller, R.E. Pieper, M.S. **Twardowski**, and J.R.V. Zaneveld. 2005. Monitoring water transparency and diver visibility in ports and harbors using aircraft hyperspectral remote sensing. *Proceedings from SPIE Port and Harbor Security Conference*, Vol. 5780, February, Orlando, FL.

Twardowski, M.S., M. Lewis, A. Barnard, J.R.V. Zaneveld. 2005. In-water instrumentation and platforms for ocean color remote sensing applications. *In: Remote Sensing of Coastal Aquatic Waters*, R. Miller and C. Del-Castillo [Eds.], Springer-Kluwer Publishing, pp. 69-100. [refereed]

- Twardowski**, M.S., J.R.V. Zaneveld, C.M. Moore, J. Mueller, C. Trees, O. Schofield, S. Freeman, T. Helble, and G. Hong. 2005. Diver visibility measured with a compact scattering-attenuation meter (SAM) compatible with AUVs and other small deployment platforms. *Proceedings from SPIE Port and Harbor Security Conference*, Vol. 5780, February, Orlando, FL.
- Zaneveld, J.R.V., M.S. **Twardowski**, M. Lewis, and A. Barnard. 2005. Radiative transfer and remote sensing. In: *Remote Sensing of Coastal Aquatic Waters*, R. Miller and C. Del-Castillo [Eds.], Springer-Kluwer Publishing, pp. 1-20. [refereed]
- Twardowski** M., and M. Jonasz. 2006. VSF at the small angles for natural dispersions and power-law slopes (www.tpdsci.com/Tpc/VsfSmlAngNatDspSlp.php). In: *Topics in Particles and Dispersion Science* (www.tpdsci.com). [refereed]
- Twardowski** M., and M. Jonasz. 2006. Power law in spectral scattering by natural dispersions: Derivation (www.tpdsci.com/Tpc/AtnCfSptPwLwNatDsp.php). In: *Topics in Particles and Dispersion Science* (www.tpdsci.com). [refereed]
- Twardowski** M., and M. Jonasz. 2006. Power law in spectral scattering by natural dispersions: Finite range of the particle diameter (www.tpdsci.com/Tpc/AtnCfSptPwLwNatDsp.php). In: *Topics in Particles and Dispersion Science* (www.tpdsci.com). [refereed]
- Zaneveld, J.R.V, M.S. **Twardowski**, and C. Moore. 2006. Total scattering coefficient meter. *Proceedings of Ocean Optics XVIII*, October 9-13, Montreal, Canada.
- Babin, M., D. Stramski, D. Marie, C. Grob, A. Sciandre, R.A. Reynolds, O. Ulloa, D. Vaultot, M. **Twardowski**, and H. Claustre. 2007. Backscattering properties of natural picoplankton populations obtained by flow cytometry sorting of open ocean water samples. *Biogeosciences*, submitted.
- Stramski, D., R. Reynolds, M. Babin, H. Claustre, S. Kaczmarek, M. Lewis, R. Rottgers, A. Sciandra, M. Stramska, and M. **Twardowski**. 2007. Relationships between the particulate organic carbon concentration and optical properties of surface waters in the South East Pacific and Atlantic Oceans. *Biogeosciences*, in review.
- Twardowski**, M.S., H. Claustre, S.A. Freeman, D. Stramski, and Y. Hout. 2007. Optical backscattering properties of the “clearest” natural waters. *Biogeosciences*, in review.