



**NAVAL  
POSTGRADUATE  
SCHOOL**

**MONTEREY, CALIFORNIA**

**Proposed Functional Architecture and Associated  
Benefits Analysis of a Common Ground Control  
Station for Unmanned Aircraft Systems**

**by**

Michael Chanda  
Julee DiPlacido  
John Dougherty  
Richard Egan  
John Kelly  
Trent Kingery

Daniel Liston  
Douglas Mousseau  
James Nadeau  
Theodore Rothman  
Lisa Smith  
Michael Supko

**March 2010**

**Approved for public release; distribution is unlimited**

**NAVAL POSTGRADUATE SCHOOL  
Monterey, California 93943-5000**

Daniel T. Oliver  
President

Leonard A. Ferrari  
Executive Vice President and Provost

This report was prepared for the Chairman of the Systems Engineering Department in partial fulfillment of the requirements for the degree of Master of Science in Systems Engineering.

Reproduction of all or part of this report is authorized.

This report was prepared by the Master of Science in Systems Engineering (MSSE) Cohort 311-0832 from Naval Air Systems Command (NAVAIR) at Patuxent River Naval Air Station, MD:

\_\_\_\_\_  
Michael Chanda

\_\_\_\_\_  
John Kelly

\_\_\_\_\_  
James Nadeau

\_\_\_\_\_  
Julee DiPlacido

\_\_\_\_\_  
Trent Kingery

\_\_\_\_\_  
Theodore Rothman

\_\_\_\_\_  
John Dougherty

\_\_\_\_\_  
Daniel Liston

\_\_\_\_\_  
Lisa Smith

\_\_\_\_\_  
Richard Egan

\_\_\_\_\_  
Douglas Mousseau

\_\_\_\_\_  
Michael Supko

Reviewed by:

\_\_\_\_\_  
Dr. Richard Millar  
Project Advisor

\_\_\_\_\_  
Dr. John Schmidt  
Project Advisor

\_\_\_\_\_  
Mr. Gregory Miller  
Project Advisor

Released by:

\_\_\_\_\_  
Dr. Clifford Whitcomb  
Chair  
Department of Systems Engineering

\_\_\_\_\_  
Dr. Karl A. Van Bibber  
Vice President and Dean of Research

|  |   |  |   |
|--|---|--|---|
| <b>REPORT DOCUMENTATION PAGE</b>   |   | Form Approved OMB No. 0704-0188                                  |   |
| Public reporting burden for this collection of information is estimated to average 1 hour per response, including the time for reviewing instruction, searching existing data sources, gathering and maintaining the data needed, and completing and reviewing the collection of information. Send comments regarding this burden estimate or any other aspect of this collection of information, including suggestions for reducing this burden, to Washington headquarters Services, Directorate for Information Operations and Reports, 1215 Jefferson Davis Highway, Suite 1204, Arlington, VA 22202-4302, and to the Office of Management and Budget, Paperwork Reduction Project (0704-0188) Washington DC 20503.  |   |  |   |
| <b>1. AGENCY USE ONLY (Leave blank)</b>  | <b>2. REPORT DATE</b><br>March 2010                             | <b>3. REPORT TYPE AND DATES COVERED</b><br>Technical Report      |   |
| <b>4. TITLE AND SUBTITLE:</b><br>Proposed Functional Architecture and Associated Benefits Analysis of a Common Ground Control Station for Unmanned Aircraft Systems  |   | <b>5. FUNDING NUMBERS</b>  |   |
| <b>6. AUTHOR(S)</b> Michael Chanda, Julee DiPlacido, John Dougherty, Richard Egan, John Kelly, Trent Kingery, Daniel Liston, Douglas Mousseau, James Nadeau, Theodore Rothman, Lisa Smith, Michael Supko   |   |  |   |
| <b>7. PERFORMING ORGANIZATION NAME(S) AND ADDRESS(ES)</b><br>Naval Postgraduate School<br>Monterey, CA 93943-5000  |   | <b>8. PERFORMING ORGANIZATION REPORT NUMBER</b><br>NPS-SE-10-002 |   |
| <b>9. SPONSORING /MONITORING AGENCY NAME(S) AND ADDRESS(ES)</b><br>N/A   |   | <b>10. SPONSORING/MONITORING AGENCY REPORT NUMBER</b>            |   |
| <b>11. SUPPLEMENTARY NOTES</b> The views expressed in this report are those of the author and do not reflect the official policy or position of the Department of Defense or the U.S. Government.  |   |  |   |
| <b>12a. DISTRIBUTION / AVAILABILITY STATEMENT</b><br>Approved for public release; distribution is unlimited  |   | <b>12b. DISTRIBUTION CODE</b><br>A                               |   |
| <b>13. ABSTRACT (maximum 200 words)</b><br><br>The proliferation of Unmanned Aerial Systems (UASs) and lack of mandated standards has led to unique Unmanned Aerial Vehicle (UAV) and Ground Control Station (GCS) designs. A former Under Secretary of Defense for Acquisition, Technology, and Logistics, stated in an Acquisition Decision Memorandum (ADM) that UAS GCS commonality could reduce manpower, procurement, sustainment and life cycle costs. While the ADM provided an impetus for commonality, it did not define a path. This project defines a common GCS functional architecture that provides the first steps on the path to UAS commonality. Stakeholder documentation was analyzed to identify areas of greatest concern and to examine previous efforts in this domain. Then, a tailored systems engineering process was employed to develop a new set of requirements which includes a common Air Vehicle Operator (AVO) Human-Machine Interface. These requirements enabled the creation of an innovative functional architecture for a common GCS concept. The utilization of this architecture has multiple operational, logistical, and financial benefits. This project quantified AVO training cost benefits and found that implementation of the common GCS architecture in accordance with the derived requirements will benefit the Department of Defense through reduced Operations and Support costs and increased operational capability. |   |  |   |
| <b>14. SUBJECT TERMS</b><br>Ground Control Station (GCS), Unmanned Aircraft System (UAS), Unmanned Aerial Vehicle (UAV), common, commonality, interoperability, architecture, training, Air Vehicle Operator (AVO), requirements, Systems Engineering (SE), Broad Area Maritime Surveillance (BAMS), Fire Scout, Small Tactical Unmanned Air System (STUAS), Basic UAS Qualification (BUQ), Acquisition Decision Memorandum (ADM), Integration Definition for Functional Modeling (IDEF0), Human-Machine Interface (HMI).  |   | <b>15. NUMBER OF PAGES</b><br>235                                | <b>16. PRICE CODE</b>                   |
| <b>17. SECURITY CLASSIFICATION OF REPORT</b><br>Unclassified   | <b>18. SECURITY CLASSIFICATION OF THIS PAGE</b><br>Unclassified | <b>19. SECURITY CLASSIFICATION OF ABSTRACT</b><br>Unclassified   | <b>20. LIMITATION OF ABSTRACT</b><br>UL |

Standard Form 298 Rev. (2-89)  
Prescribed by ANSI Std. Z39-18

THIS PAGE INTENTIONALLY LEFT BLANK

## **ABSTRACT**

The proliferation of Unmanned Aerial Systems (UASs) and lack of mandated standards has led to unique Unmanned Aerial Vehicle (UAV) and Ground Control Station (GCS) designs. A former Under Secretary of Defense for Acquisition, Technology, and Logistics, stated in an Acquisition Decision Memorandum (ADM) that UAS GCS commonality could reduce manpower, procurement, sustainment and life cycle costs. While the ADM provided an impetus for commonality, it did not define a path. This project defines a common GCS functional architecture that provides the first steps on the path to UAS commonality. Stakeholder documentation was analyzed to identify areas of greatest concern and to examine previous efforts in this domain. Then, a tailored systems engineering process was employed to develop a new set of requirements which includes a common Air Vehicle Operator (AVO) Human-Machine Interface. These requirements enabled the creation of an innovative functional architecture for a common GCS concept. The utilization of this architecture has multiple operational, logistical, and financial benefits. This project quantified AVO training cost benefits and found that implementation of the common GCS architecture in accordance with the derived requirements will benefit the Department of Defense through reduced Operations and Support costs and increased operational capability.

THIS PAGE INTENTIONALLY LEFT BLANK

# TABLE OF CONTENTS

|             |  |           |
|-------------|--|-----------|
| <b>I.</b>   | <b>INTRODUCTION AND BACKGROUND</b>   | <b>1</b>  |
| A.          | COMPONENTS OF A UAS  | 2         |
| B.          | COMMONALITY AND INTEROPERABILITY   | 6         |
| C.          | EXAMPLE COMMONALITY PROBLEM: PREDATOR AND SKY WARRIOR  | 7         |
| D.          | RESEARCH QUESTIONS   | 8         |
| E.          | PROJECT GOALS AND DELIVERABLES   | 9         |
| F.          | SYSTEMS ENGINEERING PROCESS  | 10        |
| 1.          | Information Gathering and Problem Definition   | 12        |
| 2.          | Concept Development  | 12        |
| 3.          | Engineering Development  | 12        |
| 4.          | Design Recommendations and Conclusions   | 13        |
| G.          | INTEGRATED PRODUCT TEAMS AND TEAM MEMBER ROLES   | 13        |
| <b>II.</b>  | <b>UAS AND GCS BACKGROUND INFORMATION</b>  | <b>15</b> |
| A.          | UNMANNED SYSTEMS INTEGRATED ROADMAP (FY2009-2034)  | 15        |
| B.          | GOVERNMENT ACCOUNTABILITY OFFICE REPORTS 06-49, 06-610T AND 09-520 ON UNMANNED AIRCRAFT SYSTEMS      | 16        |
| C.          | STANAG 4586: STANDARD INTERFACES OF UAV CONTROL SYSTEM FOR NATO UAV INTEROPERABILITY                 | 19        |
| D.          | USD(AT&L) ADM 2009: UNMANNED AIRCRAFT SYSTEMS GROUND CONTROL STATION ACQUISITION DECISION MEMORANDUM | 25        |
| E.          | VARIATIONS OF GROUND CONTROL STATIONS  | 28        |
| F.          | SUMMARY OF BACKGROUND INFORMATION  | 32        |
| <b>III.</b> | <b>PROBLEM DEFINITION</b>  | <b>35</b> |
| A.          | PROBLEM IN GENERAL   | 35        |
| B.          | A DETAILED DISCUSSION OF COMMONALITY VERSUS INTEROPERABILITY   | 35        |
| C.          | ELEMENTS INFLUENCING COMMONALITY AND INTEROPERABILITY  | 41        |
| 1.          | Airframe Size and Groupings  | 41        |
| 2.          | Air Vehicle Control versus Mission Specific Payload Control  | 43        |
| 3.          | Human-Machine Interface  | 45        |
| 4.          | Hardware and Software Combination  | 51        |
| 5.          | Implementation through Retrofit or New Acquisition   | 53        |
| 6.          | Department of Defense Multiservice Cooperation   | 55        |
| 7.          | United States and Allied Cooperation   | 57        |
| D.          | AREAS IMPACTED BY COMMONALITY AND INTEROPERABILITY   | 59        |
| 1.          | Training   | 59        |
| 2.          | Basing   | 61        |
| 3.          | Manpower Requirements  | 62        |
| 4.          | Personnel Assignments  | 63        |
| 5.          | Reliability and Maintainability  | 64        |
| 6.          | Other Logistical Areas   | 65        |
| 7.          | Cost   | 66        |

|  |            |
|--|------------|
| 8. Mission Capability .....  | 67         |
| <b>IV. PROBLEM SCOPING.....</b>  | <b>69</b>  |
| <b>V. TRAINING AS AN AREA OF INTEREST .....</b>                                    | <b>73</b>  |
| A. POTENTIAL BENEFITS FROM UAS AVO COMMON TRAINING.....                            | 73         |
| B. OTHER GOVERNMENT EFFORTS TOWARD COMMON UAS TRAINING.....                        | 74         |
| 1. Joint Unmanned Aircraft Systems Center of Excellence .....                      | 74         |
| 2. Joint Unmanned Aircraft Systems Levels of Qualification .....                   | 76         |
| 3. Chairman of the Joint Chiefs of Staff Instruction 3255.01 .....                 | 79         |
| 4. Fleet UAS Platform Wholeness Concept of Operations .....                        | 80         |
| C. NAVAIR AVIATION TRAINING SYSTEMS: ANALYSIS OF BASIC UAS<br>QUALIFICATIONS ..... | 81         |
| 1. BUQ-I Analysis .....  | 82         |
| 2. BUQ-II Analysis .....   | 82         |
| 3. BUQ-III Analysis.....   | 83         |
| 4. BUQ-IV Analysis .....   | 84         |
| 5. BUQ-I through IV Combined Analysis .....  | 85         |
| <b>VI. REQUIREMENTS ANALYSIS FOR A COMMON GCS.....</b>                             | <b>87</b>  |
| A. OVERVIEW OF CURRENT NAVY UAS REQUIREMENTS .....                                 | 87         |
| 1. Key Performance Parameters .....  | 87         |
| 2. Key System Attributes .....   | 89         |
| 3. CDD, CPD and System Specification Comparison .....                              | 90         |
| 4. Commonality as a New Requirement .....  | 93         |
| B. NECESSARY REQUIREMENTS FOR A COMMON GCS .....                                   | 93         |
| 1. Requirements Facilitating Common AVO Training.....                              | 93         |
| 2. Additional Requirements for a Common GCS.....                                   | 95         |
| <b>VII. JUCCS PROPOSED COMMON GCS ARCHITECTURE .....</b>                           | <b>101</b> |
| A. JUCCS ARCHITECTURAL ELEMENTS .....  | 101        |
| 1. Inspiration for the Architectural Structure .....                               | 101        |
| 2. Enabling Common AVO Training.....   | 102        |
| 3. Enabling Interoperability.....  | 102        |
| B. ARCHITECTURAL SYNTHESIS FROM AN AIR VEHICLE CONTROL PERSPECTIVE .....           | 103        |
| 1. UAS Elements and Functions.....   | 104        |
| 2. External Entities and Functions .....   | 105        |
| C. CREATING THE JUCCS FUNCTIONAL ARCHITECTURE WITH BLOCK DIAGRAMS ...              | 107        |
| 1. Top Level Hierarchy of JUCCS Architecture .....                                 | 108        |
| 2. A1 Block Diagram: Perform GCS Functions .....                                   | 109        |
| D. DOCUMENTING AND LINKING THE ARCHITECTURE WITH CORE® .....                       | 112        |
| E. JUCCS PROPOSED COMMON GCS ARCHITECTURE .....                                    | 114        |
| 1. A-1: External Systems Diagram.....  | 114        |
| 2. A0: UAS Node Diagram .....  | 116        |
| 3. A1: Perform GCS Functions .....   | 117        |
| 4. A1.1: Provide Human Interface .....   | 119        |
| 5. A1.3: Manage Mission .....  | 124        |

|   |   |            |
|---|---|------------|
| 6.  | A1.4: Command and Control Air Vehicle .....                       | 126        |
| F.  | SUMMARY OF JUCCS ARCHITECTURE AND LINKAGE TO REQUIREMENTS .....   | 130        |
| <b>VIII. IMPROVED TRAINING POSSIBILITIES WITH JUCCS COMMON GCS ARCHITECTURE .....</b> |   | <b>135</b> |
| A.  | CURRENT NAVY UAS TRAINING PRACTICES .....                         | 135        |
| 1.  | Navy Training System Plans .....                                  | 135        |
| 2.  | Current Navy UAS Training Concepts .....                          | 138        |
| B.  | PROPOSED FUTURE NAVY UAS TRAINING PRACTICES.....                  | 140        |
| 1.  | Expanded Analysis of Basic UAS Qualifications .....               | 141        |
| 2.  | Proposed Common Schoolhouse Navy UAS Pipelines .....              | 144        |
| 3.  | Quantitative Benefits Analysis of JUCCS Proposed Common GCS ..... | 146        |
| C.  | SUMMARY OF COMMON UAS TRAINING BENEFITS .....                     | 150        |
| D.  | CHALLENGES TO IMPLEMENTING COMMON UAS TRAINING.....               | 151        |
| <b>IX. CONCLUSIONS AND RECOMMENDATIONS.....</b>                                       |   | <b>153</b> |
| A.  | CONCLUSIONS .....   | 153        |
| B.  | RECOMMENDATIONS .....   | 156        |
| C.  | AREAS FOR FURTHER STUDY .....                                     | 158        |
| <b>APPENDIX A: PROJECT MANAGEMENT PLAN .....</b>                                      |   | <b>161</b> |
| <b>APPENDIX B: JUCCS TEAM LOGO.....</b>   |   | <b>195</b> |
| <b>APPENDIX C: DEFINITION OF AIRSPACES .....</b>                                      |   | <b>197</b> |
| <b>APPENDIX D: COMPLETE BUQ ANALYSIS .....</b>  |   | <b>199</b> |
| <b>APPENDIX E: DETAILED LOGIC FOR QUANTITATIVE ANALYSIS.....</b>                      |   | <b>203</b> |
| <b>APPENDIX F: ACROYMNS.....</b>  |   | <b>207</b> |
| <b>LIST OF REFERENCES.....</b>  |   | <b>213</b> |
| <b>INITIAL DISTRIBUTION LIST .....</b>  |   | <b>219</b> |

## LIST OF FIGURES

|   |     |
|---|-----|
| Figure 1. Example Detailing UAV and GCS Connections .....                                       | 2   |
| Figure 2. Links Between the GCS and UAV with Operator Functions .....                           | 5   |
| Figure 3. Tailored Systems Engineering Process for This Project .....                           | 11  |
| Figure 4. JUCCS Integrated Product Team Hierarchy .....   | 13  |
| Figure 5. Top-Level UAS Architecture as Defined by STANAG 4586 .....                            | 21  |
| Figure 6. UAS Physical Architecture as Defined by STANAG 4586 .....                             | 23  |
| Figure 7. Small Handheld AeroVironment GCS .....  | 29  |
| Figure 8. Small UAS Ground Control Station .....  | 29  |
| Figure 9. Larger UAS Ground Control Station for Global Hawk.....                                | 30  |
| Figure 10. Predator Ground Control Station .....  | 31  |
| Figure 11. Raytheon’s Universal Control Prototype Ground Control Station.....                   | 31  |
| Figure 12. Fire Scout GCS.....  | 32  |
| Figure 13. Level of Interoperability Perspective .....  | 37  |
| Figure 14. The One System Ground Control Station .....  | 39  |
| Figure 15. Remote Control used on British Army Hermes 450 UAV GCS.....                          | 47  |
| Figure 16. Predator Ground Control Station.....   | 49  |
| Figure 17. Examples of Common Symbology.....  | 50  |
| Figure 18. JUAS COE Placement within the USJFCOM Organization Structure .....                   | 75  |
| Figure 19. JUAS COE Organization Structure .....  | 76  |
| Figure 20. UAS Qualification Hierarchy.....   | 78  |
| Figure 21. BUQ-I KSA Analysis across Various UAS Training Pipelines.....                        | 82  |
| Figure 22. BUQ-II KSA Analysis across Various UAS Training Pipelines .....                      | 83  |
| Figure 23. BUQ-III KSA Analysis across Various UAS Training Pipelines .....                     | 84  |
| Figure 24. BUQ-IV KSA Analysis across Various UAS Training Pipelines .....                      | 85  |
| Figure 25. BUQ-I through IV Combined KSA Analysis across Various UAS Training<br>Pipelines..... | 86  |
| Figure 26. Timeline Showing Requirements Development for DoN UASs .....                         | 93  |
| Figure 27. JUCCS External Systems Block Diagram .....   | 104 |
| Figure 28. JUCCS UAS Block Diagram .....  | 108 |
| Figure 29. JUCCS Architecture Top Level Hierarchy .....   | 109 |

|   |     |
|---|-----|
| Figure 30. JUCCS Perform GCS Functions Block Diagram.....                   | 110 |
| Figure 31. JUCCS IDEF0 A-1 External Systems Diagram.....                    | 115 |
| Figure 32. JUCCS IDEF0 A0 UAS Node .....                                    | 116 |
| Figure 33. JUCCS IDEF0 A1 Perform GCS Functions .....                       | 118 |
| Figure 34. JUCCS IDEF0 A11 Provide Human Interface.....                     | 120 |
| Figure 35. JUCCS IDEF0 A114 Interface with Mission Management Control ..... | 122 |
| Figure 36. JUCCS IDEF0 A1142 Interface with Air Vehicle Control .....       | 123 |
| Figure 37. JUCCS IDEF0 A13 Manage Mission.....                              | 125 |
| Figure 38. JUCCS IDEF0 A14 Command and Control Air Vehicle .....            | 127 |
| Figure 39. JUCCS IDEF0 A141 Control Air Vehicle.....                        | 128 |
| Figure 40. JUCCS IDEF0 A142 Monitor Air Vehicle .....                       | 129 |
| Figure 41. BAMS Training Pipeline .....                                     | 136 |
| Figure 42. Fire Scout Training Pipeline .....                               | 137 |
| Figure 43. MH-60 Fleet Concentration Areas .....                            | 139 |
| Figure 44. Current UAS Training Locations .....                             | 140 |
| Figure 45. PMA-205 Notional Operator Training Path .....                    | 145 |
| Figure 46. JUCCS Notional Operator Training Path .....                      | 146 |

## LIST OF TABLES

|   |     |
|---|-----|
| Table 1. Levels of Interoperability .....   | 22  |
| Table 2. Common versus Vehicle-Specific Functions of UAS .....  | 40  |
| Table 3. UAS Categorization in Groups.....  | 42  |
| Table 4. Minimum BUQ requirements for Each UAS Group .....  | 80  |
| Table 5. Comparison of DoN UAS Key Performance Parameters .....   | 88  |
| Table 6. CDD and CPD Wording Related to Training for DoN UASs.....                                      | 91  |
| Table 7. System Specification Wording Related to Training for DoN UASs .....                            | 92  |
| Table 8. Necessary Requirements for a Common GCS .....  | 97  |
| Table 9. Linkage of JUCCS Architectural Elements to Requirements .....                                  | 131 |
| Table 10. Sample of Expanded BUQ Analysis Based on Architecture Type .....                              | 142 |
| Table 11. Reduction of Unique KSAs for the JUCCS Proposed Common versus As-Is<br>GCS Architectures..... | 143 |
| Table 12. High Level Analysis of O&S Costs of Different Training Options .....                          | 149 |

## **EXECUTIVE SUMMARY**

The proliferation of Unmanned Aerial Systems (UASs) and lack of mandated standards has led to unique Unmanned Aerial Vehicle (UAV) and Ground Control Station (GCS) designs. A former Under Secretary of Defense for Acquisition, Technology, and Logistics, stated in a 2009 Acquisition Decision Memorandum (ADM) that commonality in UAS GCSs would reduce Department of Defense (DoD) acquisition manpower, procurement, sustainment, and life-cycle costs. He went on to profess that increased commonality could improve interoperability for joint and combined UAS operations. This project develops twelve necessary UAS requirements to produce a proposed functional architecture for a common GCS. This architecture enables greater commonality and interoperability among UASs. Additionally, it was determined that cost savings could be realized by implementing this common GCS concept.

To approach the problem, a tailored systems engineering process was implemented. The first step included information gathering to obtain background data about existing and proposed UASs and commonality concepts. This phase explored UAS Integrated Roadmaps, Government Accountability Office (GAO) reports, North Atlantic Treaty Organization (NATO) Standard Agreement (STANAG) documents, and the ADM that initially called for GCS commonality. The UAS Integrated Roadmap, various GAO reports, and the previously discussed ADM all call for increased commonality between both inter-service and intra-service GCS designs. These documents surmised that such goals could be met with the use of modular, open source, standardized systems. A survey of current GCSs clearly indicates a lack of commonality across the DoD and illustrates the problems resulting from such an uncoordinated development approach. Even UASs of similar sizes and missions utilize non-standard control systems that do not facilitate commonality or interoperability. A review of literature has revealed that UAS commonality is desired, but no guidelines for implementation have been provided.

Next, stakeholder feedback was gathered, and background information was utilized to scope the direction of the project. This led to a focus on the need for a common Human-Machine Interface (HMI) for the air vehicle control functions of Groups

3-5 UASs. Additionally, the project was limited to Department of Navy (DoN) assets due to information accessibility and Naval Air Systems Command (NAVAIR) recommendations. Further scoping limited the quantitative benefits analysis to Operations and Support (O&S) costs for training UAS Air Vehicle Operators (AVOs).

To compare the requirements of current DoN acquisition programs with the project scope, a detailed survey of the Broad Area Maritime Surveillance (BAMS) UAS, Vertical Take-off and Land Tactical UAV (VTUAV, known as Fire Scout), and Small Tactical Unmanned Air System (STUAS) requirements documents was performed. The Key Performance Parameters and Key System Attributes of each system were compared and contrasted. The resulting analysis produced a list of twelve requirements necessary for the creation of a common functional GCS architecture that supports AVO functions.

The list of requirements led to the creation of a proposed common GCS architecture. The Model Based Systems Engineering program CORE<sup>®</sup> was used to show the architectural concept through the Integration Definition for Functional Modeling (IDEF0) language. Each sub-function was then modeled in IDEF0 to ensure consistent data flow between levels. A high level benefits analysis was performed assuming the implementation of the proposed common GCS architecture. This analysis was limited to the AVO functions required for Basic UAS Qualifications. It showed a potential cost savings of over \$400 million in O&S for training aspects of the GCS common architecture over a twenty year span. This quantification did not include potential benefits other than those found in training, and additional benefits can be expected when other logistical elements are analyzed.

Utilizing a common GCS architecture would enable benefits in the areas of basing, manpower requirements, personnel assignments, reliability, maintainability, interoperability and training. This project quantified AVO training cost benefits and found that implementation of the common GCS architecture in accordance with the derived requirements will benefit the Department of Defense through reduced O&S costs and increased operational capability.

## I. INTRODUCTION AND BACKGROUND

Unmanned Aircraft Systems (UASs) have become an integral part of the United States armed forces as well as other militaries around the world. “When the U.S. forces went into Iraq in 2003, the military had fewer than 170 unmanned aerial systems... By 2008, the number of unmanned aerial systems had reached 6,358” [Firebaugh, 2009]. In the U.S. inventory, the acquisition process of buying complete systems in a single program from a single prime contractor has led to a Ground Control Station (GCS) being purchased with each type of new Unmanned Air Vehicle (UAV). The proliferation of UASs, including each unique GCS, has resulted in a procurement and development process that has not had a chance to generate, accept, and mandate common standards.

This proliferation has led to a lack of commonality and interoperability among UASs. Mr. John Young, a former Under Secretary of Defense for Acquisition, Technology, and Logistics (USD(AT&L)), stated in a 2009 Acquisition Decision Memorandum (ADM) that commonality in UAS GCSs could reduce Department of Defense (DoD) manpower, procurement, sustainment, and logistics costs, and that interoperability could improve joint and combined operations. He went on to state his thoughts on the importance by saying “...the acquisition team has the opportunity to do something truly joint and powerful by adopting a common GCS architecture that is open and thus will allow for rapid addition of modular functionality” [USD(AT&L), 2009].

To prove his point, Mr. Young stated that if certain provisions in the ADM were not addressed, he “...may restrict funding obligations on the UAS GCS development and/or procurement contract...” [USD(AT&L), 2009]. This statement has not been taken lightly by the acquisition community and reveals the immediacy of the action required for investigation of the problem at hand.

## A. COMPONENTS OF A UAS

A UAS consists of one or more UAVs and a GCS. A GCS is the interface and conduit between human users, or operators, and the UAVs. The GCS also receives and disseminates information to outside elements including military commands and air traffic control. A GCS is not limited to the *ground*, but can also be onboard a ship, vehicle, submarine, or airborne platform. For the purposes of this report, GCS will be used as the generic term referring to the control element of the UAV. Figure 1 shows an example from a UAS airspace integration brief that highlights the complex connections between the UAVs, GCSs and other entities within the UAS environment. It can be seen in this figure that the GCS is the central element for interactions between the operators, UAVs, other aircraft, ground support elements, air traffic control and command authorities.

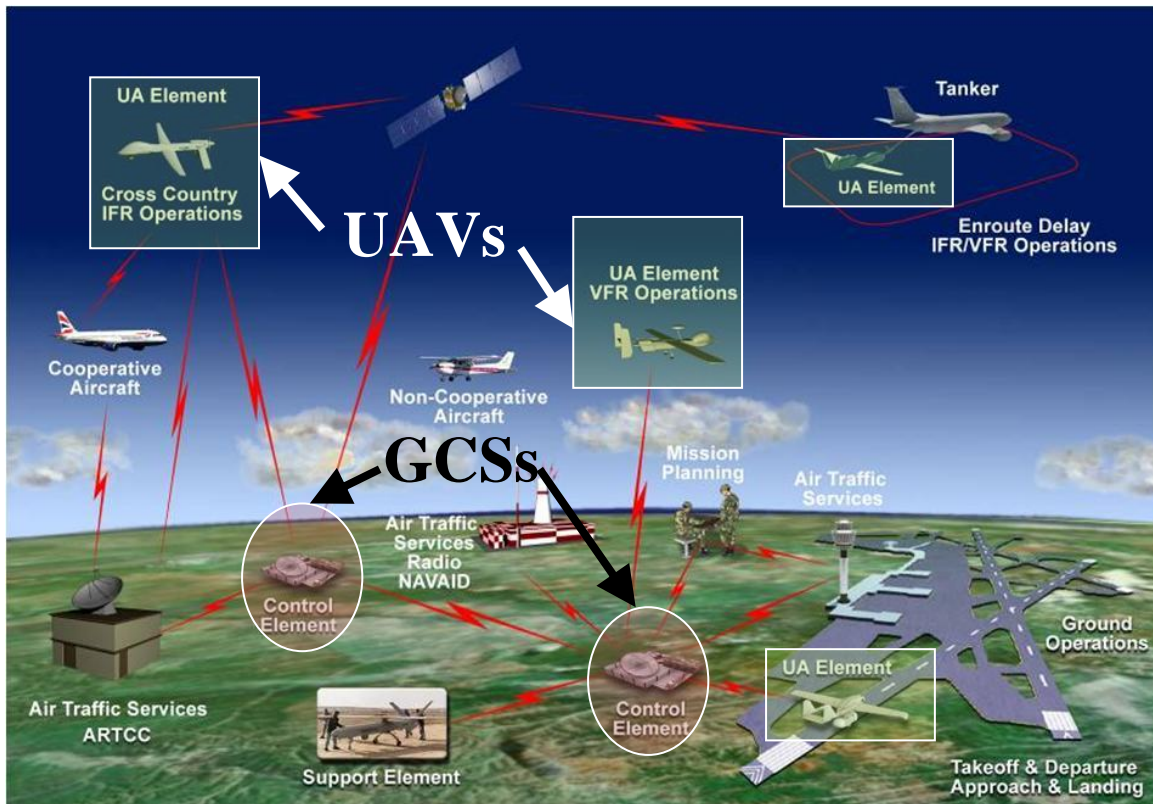

**Figure 1. Example Detailing UAV and GCS Connections**

*This diagram shows an example of the connections between a UAV, a GCS and other entities within the UAS environment. Methods of communication and types of GCSs will vary based on type and capability of the UAS. Figure after [PMA-262, 2009].*

All user controlled functions of the UAV are input through the GCS. This includes piloting functions, navigation, sensor payload control, and in some cases weapons control. Most large UASs are staffed by two or more personnel, with at least one being an Air Vehicle Operator (AVO) and other positions being a Mission Payload Operator (MPO), other sensor operators, communications operator, etc. The key purposes of the GCSs are to function as the interface for human operators to control or direct the UAV, control the payloads (both sensors and weapons), and direct information from the UAS to the appropriate command authority.

The emphasis has been on the air vehicle component of the UAS, however a primary driver in realizing system capabilities is the GCS. The GCS houses the most vital interface found on a UAS, the connection between the human operator and the air vehicle. A UAV is different from a missile due to a high level of interaction between the operator and the air vehicle, allowing real time mission flexibility and tasking. Through the GCS interface, the operator (or team of operators), command desired air vehicle functionality including takeoff and landing, navigation, sensor operation, and weapons delivery. The GCS may also serve as the intelligence center, where raw, actionable data is analyzed, mensurated, and relayed to other combat assets. Legacy GCS development and deployment has been conducted in a proprietary manner, which has lead to *stovepiped* systems that are not common or interoperable across different UASs [National Defense Industrial Association (NDIA), 2003]. A need for a change for future systems was recognized by the recent ADM dictating that the DoD services develop and implement plans to increase synergies across current and future systems [USD(AT&L), 2009].

The GCS is responsible for several functions contained within the UAS architecture. The first function is to allow the AVO to control and monitor the UAV. The AVO commands air vehicle navigation and maneuver parameters through the GCS. Different human interfaces are employed by current GCSs to accomplish this task, including the use of *stick-and-rudder* type designs, as well as *point-and-click* computer based designs. The second aspect of this function is to monitor the health and equipment status of the UAV. The GCS houses the displays that allow the AVO to detect

malfunctions and enact corrective measures when necessary. The monitoring function of onboard UAV sensors also allows the AVO to determine which sensors are operational, thus driving the tactics employed in conducting the UAS mission.

The control and operation of the UAV sensors and weapons is another vital function of the GCS, as they provide the true warfighting capability. Different UASs employ different sensors with different capabilities. Each GCS must be able to operate its corresponding sensors and provide information to the sensor operator and other crewmembers. Currently there are many different sensor operator interfaces to match the number of different sensors employed by UASs. These sensors usually provide the targeting data required to employ the various weapons carried by different UAVs. The man-in-the-loop aspect required to launch weapons is a critical GCS interface. The ability for the mission commander to conduct hostile engagements is directly related to the quality of the information the GCS can display.

These operations require a robust method of communication between the GCS and UAV. This is a vital interface, and can vary based on the size and mission of the UAS. The two basic categories of air vehicle control links are Line-Of-Sight (LOS), which is generally employed on smaller UAVs, and Over-The-Horizon (OTH), which is employed on larger UAVs. These can be implemented in various ways and several different data links are currently used. OTH data links are usually done via a satellite data link. This can present problems due to the limited bandwidth available, especially in some cases where military traffic is carried by commercial satellite systems with no overriding priority. With the growing number of large OTH UASs, the available satellite bandwidth is another consideration that the GCS must accommodate. These links, along with the UAS operator functions are shown in Figure 2.

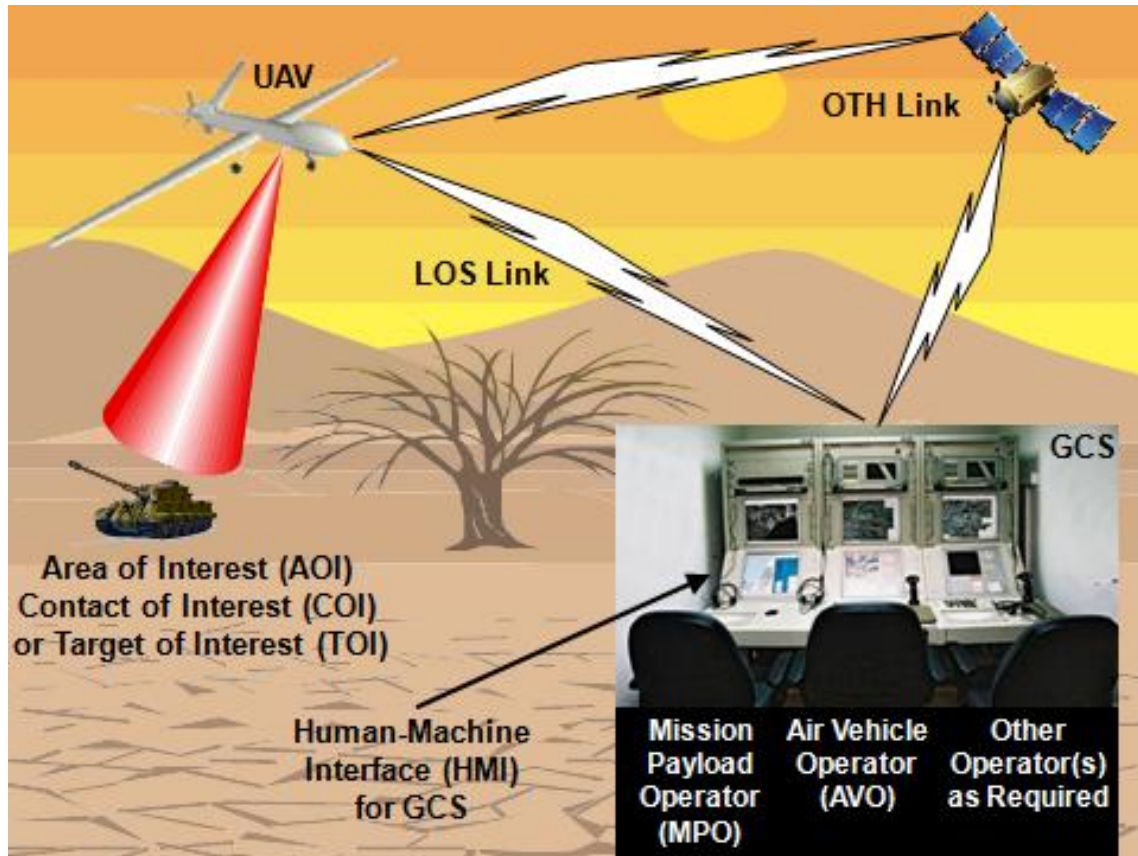

**Figure 2. Links Between the GCS and UAV with Operator Functions**

*This figure shows the communication links between the GCS and the UAV. Additionally, the roles of the UAS operators are shown in the GCS portion of the figure. The Human-Machine Interface (HMI) is used by the operators to enter commands to the UAV through the GCS. Figure after [IHS (Global) Limited, 2009].*

A final important area of GCS architecture is the contingency planning and monitoring of the UAS. While the UAV is responsible for executing pre-planned contingency measures, the GCS provides the means to program them into the UAV flight control logic. Three of the general contingency plans that need to be accounted for, and pre-programmed are:

- What should the UAV do if the air vehicle control data link should fail and the UAV can no longer receive commands from the ground?
- What should the UAV do in the event of a loss of the engine (especially if the data link has been lost)?

- What should the UAV do in the case of extreme emergency (engine fire, etc, especially if the data link has been previously lost)?

There may be alternate methods of performing these contingency functions in future UAS designs, however, contingency planning is currently considered a vital function of a GCS.

## **B. COMMONALITY AND INTEROPERABILITY**

While the concepts of commonality and interoperability are generally understood, exact definitions are more difficult to articulate. Commonality is often described at a high level as the ability to use the same hardware, software or data links. The ability to communicate between different types of UASs is described as interoperability, but it is often associated with commonality. Properly defining commonality and interoperability is a challenging issue among many DoD UAS user groups. The primary focus of this project is defining commonality with the realization that commonality tends to enable interoperability.

The current generation of UASs has been in development for defense applications since the 1980s [Government Accountability Office (GAO), 2006]. Commonality among subsystems, payloads, and ground control stations have not yet been attained [GAO, 2009]. This lack of commonality is seen not only between cross-service UASs, but also within Department of the Navy (DoN) acquired UASs. All DoN UASs are currently developed with unique dedicated GCSs.

The current DoD acquisition process leads to a lack of commonality because each UAV system is procured as if it were a single aircraft. This condition is referred to as *stovepiping* as it results from a lack of coordination between program offices on issues such as commonality. Therefore, each system component, both UAV and paired GCS are developed together as standalone systems. “In an effort to minimize ‘stovepiping,’ Congress has mandated that all unmanned aircraft weighing more than 45 pounds must transition to a tactical common datalink that will enable them to inter-operate with various ground technologies” [Jean, 2009].

Another barrier to obtaining DoD commonality is that “manufacturers have been reluctant to share their proprietary communications datalink formats with other companies. They produce ground stations that control only their specific aircraft, which means that the services often have to buy the complete package of Air Vehicle (AV) and GCS. That has proven cumbersome and inefficient because the equipment is not compatible with aircraft made by other manufacturers” [Jean, 2009]. Raytheon, a company that makes independent GCSs, stated “we, the ground system providers, are being held hostage by the platform providers” [Jean, 2009]. Therefore, as more systems are being acquired by the DoN, the population and variety of GCS equipment has begun to proliferate with few effective efforts to increase commonality in hardware, software, or logistics. Additionally, GCSs have proven not to be interoperable, resulting in reduced operational effectiveness. A detailed discussion about commonality and interoperability can be found in Chapter III.B.

### **C. EXAMPLE COMMONALITY PROBLEM: PREDATOR AND SKY WARRIOR**

In 2001, the U.S. Army began to develop requirements to replace the legacy RQ-5 Hunter UAS. The U.S. Army was having problems accessing and tasking the small number of UASs in the DoD inventory, specifically the U.S. Air Force (USAF) Predator systems. Due to the lack of access to USAF Predators, the U.S. Army decided to begin its own program citing ground commanders’ “urgent need for this capability” [GAO, 2009]. The U.S. Army put out their own request for proposal, conducted their own source selection and chose the MQ-1C Sky Warrior. The requirements for the new U.S. Army UAV program appeared to be very similar to the already existing Predator. As stated in a 2009 GAO report, “Both the Air Force and the Joint Staff responsible for reviewing Sky Warrior’s requirements and acquisition documentation raised concerns about duplicating existing capability – specifically, capability provided by Predator.”

The U.S. Army could have purchased Predators or helped in the development of the follow-on Predator-B (Reaper), but instead used the *urgent need* to push their own uncommon system through. This decision was made to ensure their service-specific

requirements were not affected by the USAF if a joint solution was pursued. General Atomics won the U.S. Army source selection and bid a larger (and unique) variant of its USAF Predator. The U.S. Army developed this system as the Sky Warrior instead of joining a Reaper or Predator development [GAO, 2009].

It is important to note that the GCS for the USAF Predator is not common or interoperable with the U.S. Army Sky Warrior. “The ground control station the Army is developing for Sky Warrior is expected to be used to control other Army unmanned aircraft, it will not be common with the Predator and Reaper ground control station used by the Air Force” [GAO, 2009]. While the U.S. Army is trying to be common with U.S. Army GCSs, these nearly identical systems cannot communicate or control each other. The GCS for the U.S. Army adds an automatic takeoff and landing capability missing on the Predator GCS, making it considerably different from its USAF counterpart.

This example shows the complexity and difficulty in accomplishing common UAS solutions even when missions and requirements are similar. Individual services within the DoD are rarely willing to compromise on service-specific needs, even when confronted with the expense of an entirely unique acquisition program.

#### **D. RESEARCH QUESTIONS**

The implication of a common UAS ground control station leads to some interesting research questions. The following five research questions guided the direction of this project’s research and analysis:

*Research Question 1.* What is meant by *common* and what is this project’s interpretation of *common*?

*Research Question 2.* Is there a link between *commonality* and *interoperability*?

*Research Question 3.* Is it possible to achieve some level of commonality for UAS GCSs, and if so, what requirements are necessary?

*Research Question 4.* To meet these requirements, what architectural characteristics need to be developed?

*Research Question 5.* What are some of the benefits and challenges of achieving UAS GCS commonality?

## **E. PROJECT GOALS AND DELIVERABLES**

The primary goal of this project was to investigate the challenging aspects of creating common UAS GCSs and the potential benefits of achieving this commonality. Efforts leading to this goal included conducting a detailed survey of available background information related to UASs and GCSs. Commonality and interoperability concerns with respect to these GCSs have been explored.

After adequate background information was compiled, high level requirements for a common GCS were developed based on multiple sources. These sources ranged from existing requirements from current DoN programs, other governmental documents, and concept of operations from UAS communities. The final list of extracted requirements included twelve detailed elements that would ensure the capability to enable common AVO training and would allow for GCS interoperability between platforms.

These requirements were utilized to create a functional architecture. The functional architecture was taken to a fifth level of decomposition in some cases, to ensure adequate detail for proper implementation. The final deliverable includes a hyperlinked architecture that allows for point-and-click decomposition of hierarchical levels.

After the functional architecture was developed, a small subset of possible benefits from achieving commonality was explored. This benefits analysis was used to show some of the quantifiable advantages that the DoN could gain by pursuing the common GCS architecture.

The breadth of the project required limiting the scope of the efforts in order to achieve the goals in the time allotted. The commonality aspect for the proposed GCS architecture was limited to the air vehicle control operations performed by the AVO only. Additionally, the architecture was limited to functional vice physical allocations. The benefits that could be expected from implementing the proposed common GCS architecture were limited to those related to common AVO training only. This effort did

not include a detailed cost-benefit analysis due to limited time and resources. Further details regarding the scoping of the project can be found in Chapter IV.

## **F. SYSTEMS ENGINEERING PROCESS**

The systems engineering method utilized for this project was a tailored approach to the process presented in *Systems Engineering Principles and Practice* [Kossiakoff & Sweet, 2003]. This method describes three phases of systems engineering as Concept Development, Engineering Development and Post Development. For the purposes of this project, much of the work was contained in the Concept Development and Engineering Development phases. Additional documentation of the tailored systems engineering process can be found in the Project Management Plan in Appendix A.

The generic systems engineering process was then tailored specifically for use in this project. The tailored process, as shown in Figure 3 on the next page, is divided into four phases: *Information Gathering and Problem Definition*, *Concept Development*, *Engineering Development*, and *Design Recommendations and Conclusions*.

The method began with *Information Gathering and Problem Definition*. Once the problem had been defined, the iterative phase of *Concept Development* was initiated. This iteration continued until an initial functional architecture had been created that satisfied critical functional requirements. Next, the *Engineering Development* iterated until a final functional architecture had been developed that met detailed requirements based on stakeholder feedback. Lastly, the *Design Recommendations and Conclusions* were produced. Problem scoping and stakeholder feedback loops were utilized throughout the process as shown in Figure 3.

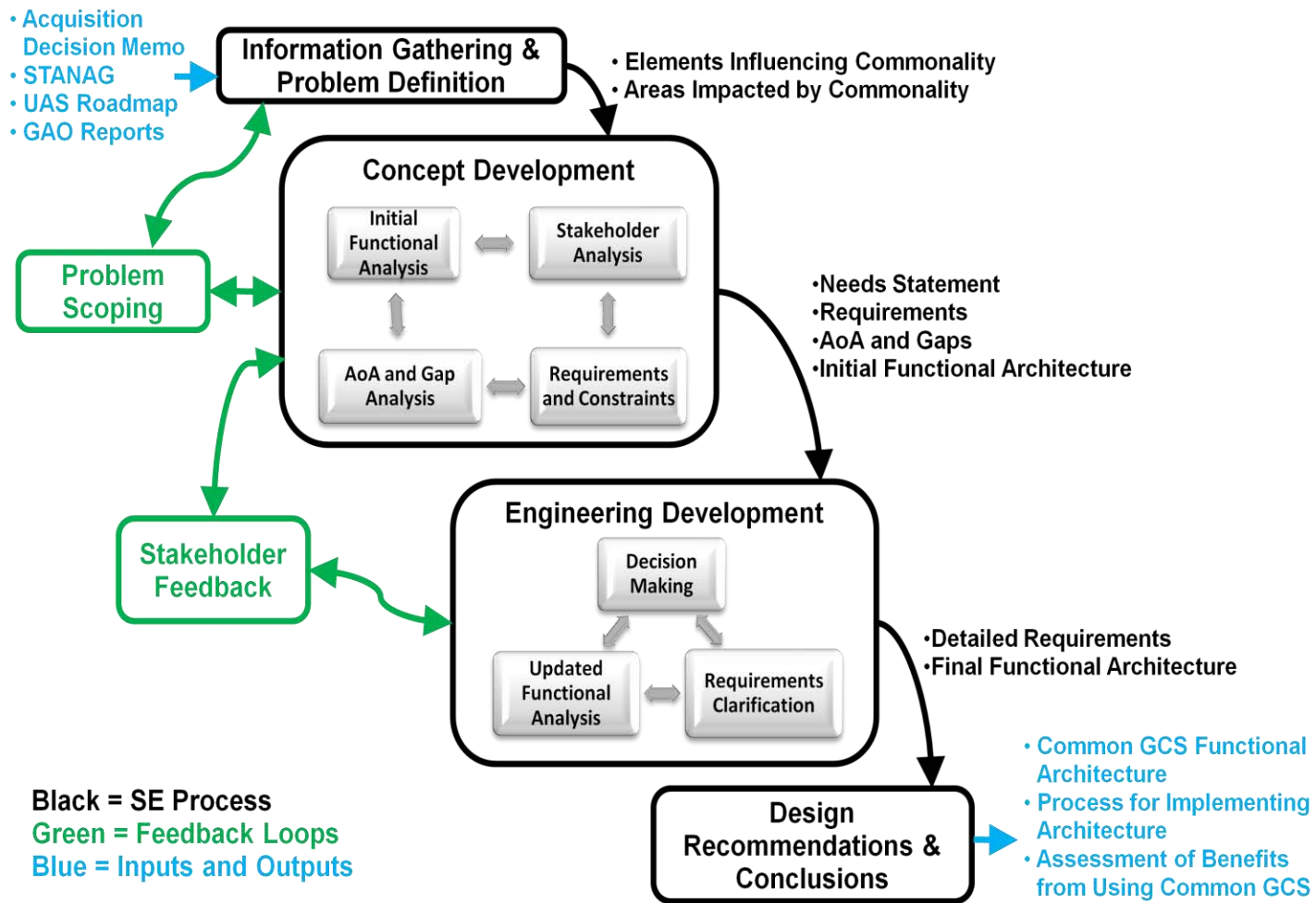

**Figure 3. Tailored Systems Engineering Process for This Project**

*This figure is the tailored systems engineering process for this project. The process is divided into four phases of Information Gathering & Problem Definition, Concept Development, Engineering Development and Design Recommendations & Conclusions.*

### ***1. Information Gathering and Problem Definition***

The first phase of the systems engineering process included defining the problem and gathering information. The problem was initially presented by Naval Air Systems Command (NAVAIR) as a topic of interest for further study. In addition to the guidance from NAVAIR, other efforts included conducting a survey of available documentation to further define the problem related to GCS commonality. After the problem was properly defined, existing systems were researched to provide an adequate background for further studies.

After information gathering, an initial scoping of the problem occurred. This problem scoping was iterative with the concept development phase to ensure the objectives of the program were achieved in the timeframe allowed.

### ***2. Concept Development***

In the concept development phase, the team performed a stakeholder needs analysis to determine the requirements and priorities of the stakeholders. The initial step was to ensure the correct set of stakeholders had been identified. The team then elicited the stakeholders' requirements and priorities potentially affected by GCS commonality. Requirements and constraints were defined and analyzed in relation to the problem statement.

An initial functional analysis of legacy GCS architectures was performed to identify critical functional requirements for common GCSs. It was found that existing GCS architectures would not meet all of the requirements for a common GCS. Therefore, a new common GCS functional architecture was developed. This functional analysis yielded an initial functional architecture at a high, conceptual level.

### ***3. Engineering Development***

In the engineering development phase, the initial functional architecture was further developed into a final functional architecture for a common GCS. It is important to note that the functional architecture did not include any physical allocation for the

common GCS. Additionally, the engineering development phase performed an analysis of potential benefits from achieving this common GCS architecture.

#### **4. Design Recommendations and Conclusions**

The final phase in the defined systems engineering process utilized the information from the preceding phases to formulate recommendations on the future application of the proposed common GCS architecture to the stakeholders.

The final recommendation for U.S. Navy (USN) acquisition programs was to adopt the common GCS functional architecture provided in this report as a basis for further design. Further, the benefits in training afforded by this architecture can only be realized through consolidation of training infrastructure among those same programs.

#### **G. INTEGRATED PRODUCT TEAMS AND TEAM MEMBER ROLES**

To facilitate work on the project, the Capstone group formed a team named the Joint UAS Common Control Station (JUCCS). A logo was developed as part of the team forming process and can be seen in Appendix B. The JUCCS team broke into Integrated Product Teams (IPTs) to perform the systems engineering process that was defined in previous sections. The IPT hierarchy can be seen in Figure 4. The roles and responsibilities of the individual IPTs are defined in the following paragraphs.

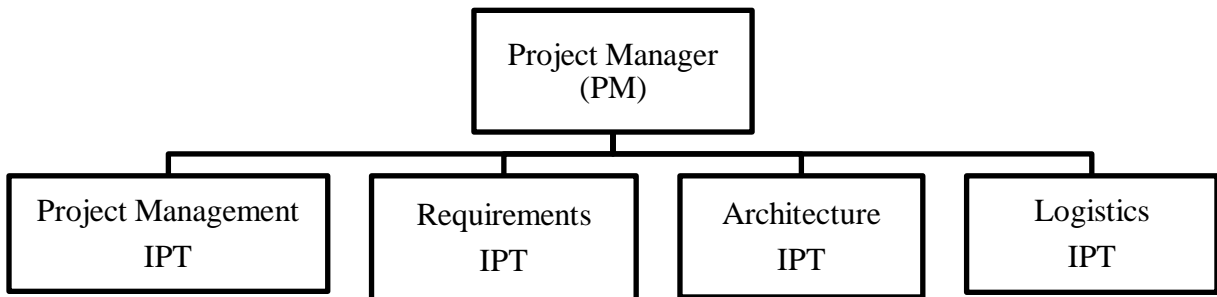

**Figure 4. JUCCS Integrated Product Team Hierarchy**

*The IPT hierarchy can be seen in this figure. The PM is at the top of the hierarchy with the individual IPTs reporting upward to the PM. The structure includes representatives for Project Management, Requirements, Architecture and Logistics.*

The Project Manager (PM) was responsible for managing all IPTs within the organizational structure of the Capstone project. The PM made executive decisions at times when matters were not agreed upon by the team members. The PM was the primary point of contact between the project advisors, external stakeholders, and the Capstone team members.

The Requirements IPT was responsible for compiling requirements documents from existing DoN UAS programs in support of the requirements and constraint analysis. The analysis from the requirements IPT aided with the architectural development.

The Architecture IPT was responsible for defining and implementing the proposed common architecture. Tasking included creation of an upper level list of requirements, functional decomposition and proposed functional architecture. The architecture team members used the CORE<sup>®</sup> software package as their primary tool.

The Logistics IPT was responsible for assessing potential benefits of implementing the common architecture designed by the Architecture IPT. The assessment included benefits that could be expected from a logistical, primarily training standpoint. Tasking included development of appropriate metrics and meetings with stakeholders.

The Project Management IPT was responsible for assisting the PM with all project management efforts including schedule generation and the compilation of document deliverables. The Project Management IPT included editors, configuration managers, and a scheduler. The editors were responsible for the proper editing of all document deliverables. The configuration managers were responsible for configuration control and administration of the learning management system used for the project. The scheduler was responsible for maintaining the master project schedule.

## II. UAS AND GCS BACKGROUND INFORMATION

This section provides a general overview of GCSs, their components, and respective functions based on a limited number of documents that are directly relevant to the discussion of commonality and interoperability with respect to UAS GCSs. The most relevant documents reviewed were the Office of the Secretary of Defense (OSD) Unmanned Systems Integrated Roadmap (2009), GAO commonality and interoperability reports (March 2005; December 2005; 2006; 2009), STANAG 4586 (2007), and the ADM from USD(AT&L) (2009). These documents are analyzed and referenced in this project. There are other documents from sources such as American Institute of Aeronautics and Astronautics (AIAA), National Aeronautics and Space Administration (NASA) along with documents from various other countries, which were analyzed for relevance, but are not cited in this background section. Many of these documents are referenced within specific sections of the paper as appropriate.

### A. UNMANNED SYSTEMS INTEGRATED ROADMAP (FY2009-2034)

The second edition of the *FY2009-2034 Unmanned Systems Integrated Roadmap* [OSD, 2009] provides a DoD-wide vision for the future of unmanned systems. It lays out the potential missions that unmanned systems could perform in the future, describes the functionality and performance needed to execute these missions, and identifies common areas of technology maturation that can lead to performance improvements for all unmanned systems: UASs, Unmanned Ground Vehicles (UGVs), and Unmanned Maritime Systems (UMSs). The OSD Roadmap also reflects the guidance set forth in Section 141 of the John Warner National Defense Authorization Act for FY2007 (Public Law 109-364) to address joint development and procurement of unmanned systems and components, to transition service unique unmanned systems to joint systems, to evaluate the organizational structure for effective management, and to coordinate and budget for the development and procurement of unmanned systems.

As reported by the OSD Roadmap, the technology of today in conjunction with the projected advancements of the future will enable a single platform to perform multiple missions across a variety of mission capability areas. For example, all four

services currently employ multiple UASs to carry out a variety of missions. The OSD Roadmap asserts that the DoD has an opportunity to realize a greater return on investment by achieving a common UAS with multi-mission capabilities rather than investing in mission-unique solutions. It recommends that the DoD “promote the development, adoption, and enforcement of Government, international, and commercial standards for the design, manufacturing, testing, and safe operation of unmanned systems.”

The OSD Roadmap also contends that interoperability will help the DoD achieve its vision by enhancing operational synergy during mission execution and by simplifying logistical elements. Interoperability among unmanned systems enables information sharing that facilitates situational awareness of ground combatant commanders. According to the OSD Roadmap, interoperability can be achieved through the acquisition of common components, systems, and software, or by building systems to common interoperability standards.

While the OSD Roadmap proposes that the DoD strive for commonality and interoperability, it provides no specific direction on how to achieve them. It recommends common standards but does not provide one. The OSD Roadmap itself states that it does not “create operational concepts, identify requirements, or program funds to invest in technology development and system acquisition. . . [and it] does not supersede the need for the Department to conduct the analysis and decision making associated with identifying the best means to satisfy capability gaps” [OSD, 2009]. In essence, the OSD Roadmap directs the DoD to be common and interoperable but it does not provide the tools necessary to achieve these goals.

## **B. GOVERNMENT ACCOUNTABILITY OFFICE REPORTS 06-49, 06-610T AND 09-520 ON UNMANNED AIRCRAFT SYSTEMS**

The Government Accountability Office (GAO), which is charged with auditing the Government and its activities, has been investigating the status of unmanned systems since early 1988 [GAO, December 2005]. Within the last decade, the GAO has released reports and testimony to Congress addressing commonality, interoperability, operational

performance, and the DoD's acquisition management approach to the growing demand for UASs. While the DoD has experienced operational success with UASs, it is still challenged with maximizing its acquisition resources and effectively integrating these assets into joint combat operations.

With the DoD's plans to invest more than \$16 billion from 2008 through 2013 to develop and procure additional UASs, the acquisition of such systems has come under scrutiny. For the ten unmanned aircraft acquisition programs that GAO reviewed in 2009, total development costs have surpassed initial estimates by over \$3 billion, or 37 percent [GAO, 2009]. Such over-runs put strain on acquisition resources, which can lead to performance tradeoffs.

The DoD recognizes the need for greater commonality among UASs in order to more effectively leverage its acquisition resources. The National Defense Authorization Act for fiscal year 2009 identifies commonality objectives that Congress expects unmanned system policy and acquisition strategy to achieve. Those objectives include: the procurement of common payloads by vehicle class, achieving commonality of ground system architecture, common management of vehicle and payload procurements, ground station interoperability standardization, and common standards for exchanging data and metadata [GAO, 2009].

Although UASs have seen success in the operational environment, their effective integration into joint combat operations remains a challenge [GAO, 2006]. Not all UASs are able to easily exchange data with other communication systems because they were not designed to interoperable communications standards [GAO, December 2005]. Joint operations have been hampered when communication systems are incompatible. For example, operating forces may be required to operate their own UASs to accomplish a mission, rather than using UASs that are already operating in the same area. "To permit the sharing of tactical intelligence obtained by unmanned aircraft sensors, the Services or combatant commands have developed certain technical patches that permit compatibility but slow data transmission" [GAO, 2006]. Timely dissemination of information is critical to combat operations as delays in the receipt of the information can undermine

U.S. forces' ability to attack time-critical targets or allow the targets to escape [GAO, December 2005]. The commander of U.S. Central Command recently testified that experiences to date highlight the importance of an established interoperability standard for all intelligence systems that can function in a joint and combined environment [GAO, 2006].

Although DoD doctrine requires interoperability, no specific standards or detailed instruction exist, and no organization has been given the authority to enforce program direction [GAO, 2006]. The DoD specifies that systems, units, and forces shall be able to provide and accept data and information to and from other systems and shall effectively interoperate with other U.S. forces [GAO, December 2005]. It does not, however, provide guidance on how this is to be accomplished. The National Defense Authorization Act for Fiscal Year 2009 identifies Congress' objectives for UAS policy and acquisition strategy. The Act, however, provides no guidance or direction on how to achieve the desired commonality, or how to measure success.

While the 2002 version of the *Unmanned Aerial Vehicles Roadmap* [OSD, 2002] emphasizes the need for UAS interoperability and identifies a number of existing standards for which systems should comply, it indicates that detailed standards for interoperability have not yet been developed [GAO, December 2005]. This situation still exists today with current systems. GAO has reported that the OSD Roadmap describes desired capabilities for UASs such as commonality, integration, and interoperability, but crucial elements of how to develop and implement a strategic plan are lacking. It does not provide specific guidance on UAS development, such as a clear link among the goals, desired capabilities, and plans. Additionally the OSD Roadmap does not provide specific guidance on related force structure integration to sufficiently address the interrelationship among service plans to each other and how they promote joint operations, opportunities for joint endeavors, investment priorities and related funding needs [GAO, 2006].

The USD(AT&L) created the Joint UAV Planning Task Force in October 2001. The Task Force is the DoD's focal point for helping establish interoperability standards. Although the Task Force aims to guide UAS acquisition, planning, prioritization, and

execution across services, it does not have sufficient authority to enforce program direction [GAO, March 2005].

The development and implementation of appropriate interoperability standards will help achieve successful integration and interoperability of UASs, but until the DoD addresses development of non-interoperable systems and enforces common standards among the services, problems are likely to continue and possibly become more widespread as new UASs are developed and fielded. GAO has made recommendations to the Secretary of Defense to develop standards for communications interoperability and overall UAS interoperability and to establish an office with sufficient authority to enforce program direction [GAO, 2006]. GAO has also recommended that DoD establish a plan that clearly identifies “goals, requirements, programs, funding needs, performance measures, and the interrelationship of service-specific programs to each other” [GAO, March 2005].

### **C. STANAG 4586: STANDARD INTERFACES OF UAV CONTROL SYSTEM FOR NATO UAV INTEROPERABILITY**

North Atlantic Treaty Organization (NATO) Standard Agreement (STANAG) 4586 was created when the UAS acquisition community realized a shortage of standards applicable to their unique system development requirements [NATO, 2007]. While there has been generous re-use of existing commercial and military standards produced through other system developments, there is a shortage of unique and specific standards for the UAS community. As mentioned earlier, the UAS development created *stovepiped* designs and although this was fairly acceptable when the community was smaller, the recent rapid growth in the quantity of systems presently fielded has created an interoperability problem that this document was initiated to discuss.

In the DoD, recent efforts within the services have been applied to acquiring unmanned systems with increased commonality. One effort in particular has each service providing representation in a collaborative effort through participation in Office of the Under Secretary of Defense sponsored Standards and Interoperability Integrated Product Team (S&I IPT). “The S&I IPT is chartered to provide recommendations for

regulations, policies, and standards that will lead to eventual acceptance of unmanned military aircraft routinely flying among civilian, manned aircraft” [OSD, 2009]. STANAG 4586 is one of the standards that this IPT is helping to generate and define, as there is interest within the DoD to be common with NATO organizations. Meanwhile, the international community through the NATO Standardization Agency has been investigating the issue of multi-national interoperable systems. “In 1998, a NATO Specialist Team began work on a standard conceived to standardize unmanned control systems interfaces to help enable UAS interoperability” [CDL Systems, 2009]. It was their works which lead to the creation of STANAG 4586 and which the S&I IPT is playing an active role.

There are four primary items of interest which STANAG 4586 helps to define. One of the first items is a standard top-level UAS architecture, which is depicted in Figure 5. The UAS architecture is composed of four main elements: the air vehicle element, the payload element, the data link element and the UAV surface element, or more commonly referred to as ground station element. It establishes the air vehicle as an entity upon itself. The payload includes any of the equipment onboard meant to support the mission and not directly used for flight of the aircraft. It could be any form of camera, radar or any available equipment, which is to be flown on the vehicle. The data link element is the form of communication between the air vehicle and the ground element, most likely some type of Radio Frequency (RF) transmission. The ground station element is the set of equipment on the ground that controls the air vehicle and the payload systems onboard. Agreement on fundamental system architecture lays the foundation for more detailed definitions associated with interfaces and UAS elements.

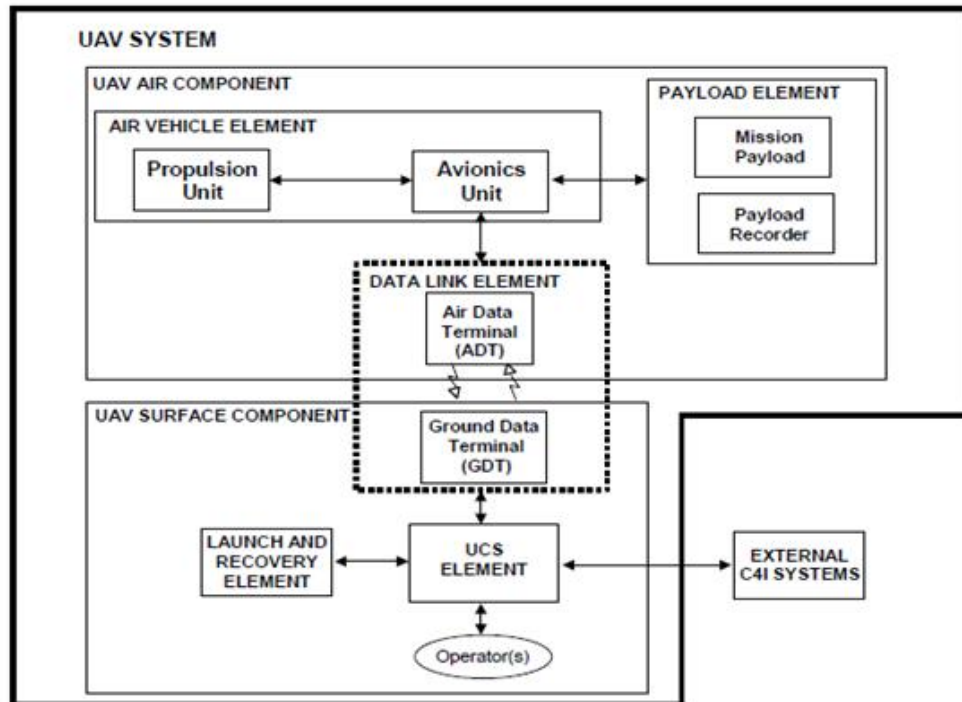

**Figure 5. Top-Level UAS Architecture as Defined by STANAG 4586**

*This diagram partitions the UAS into defined elements and shows the primary interfaces. Figure from [NATO, 2007].*

The second item of interest that STANAG 4586 addresses is the definition of Levels of Interoperability (LOIs). The LOIs are shown in Table 1. The intent for the creation of the LOIs was to assist in the understanding of various functional capabilities, which are supported by the interfaces. LOI 1 is a condition in which information originating from a UAV is passed to a third party via the GCS. LOI 2 is a condition whereby the controlling asset is directly receiving data from the UAV. LOI 3 is a condition where an asset receives strictly payload data and it is received straight from the UAV. LOI 4 is a condition where an asset is able to control just the UAV platform and not the payload systems. The control available to that asset does not include the ability to manage the UAV takeoff or landing. Finally, LOI 5 is a condition where an asset has control of the UAV for all phases of flight including takeoff and landing. It does not imply control of payload systems.

**Table 1. Levels of Interoperability**

*This table shows the five Levels of Interoperability (LOIs) and the definitions associated with each. Table after [NATO, 2007].*

| <b>LOI Level</b> | <b>Definition</b>  |
|------------------|--|
| <b>1</b>         | Indirect receipt of UAV data   |
| <b>2</b>         | Direct receipt of UAV data where <i>direct</i> covers reception of the UAV data by the GCS when it has direct communication with the UAV |
| <b>3</b>         | Control and monitoring of the UAV payload in addition to direct receipt of UAV data  |
| <b>4</b>         | Control and monitoring of the UAV, less launch and recovery  |
| <b>5</b>         | Control and monitoring of the UAV, plus launch and recovery  |

Something to consider is that an asset could have multiple LOIs at any given time. For example, a small hand-held UAV with a camera as its payload could utilize a GCS for control of the air vehicle for launch and recovery, control of the air vehicle in flight, and receipt of camera data. This encompasses LOI 2, 4 and 5. There could be a separate ground element used to monitor, control and receive the payload data, which would include LOI 2 and 3. Should these two ground elements be configured as a single item, it would have LOI 2, 3, 4 and 5.

The third item that STANAG 4586 helps define is a common physical architecture for the UAS as shown in Figure 6. Note that the language used by the STANAG calls this figure a functional architecture, but it is understood here to be a physical representation. This physical architecture takes into consideration that an AV may not directly interface with the core UAV Control System (UCS) but instead might require some translation in order to be interoperable. The Vehicle Specific Module (VSM) would host the functionality needed to translate the necessary information for a specific AV if necessary. Similarly, some translation may be required with the interface to the Command, Control, Communication, Computer and Intelligence (C4I) system. In

that case, the Command and Control Interface Specific Module (CCISM) would perform the necessary translation.

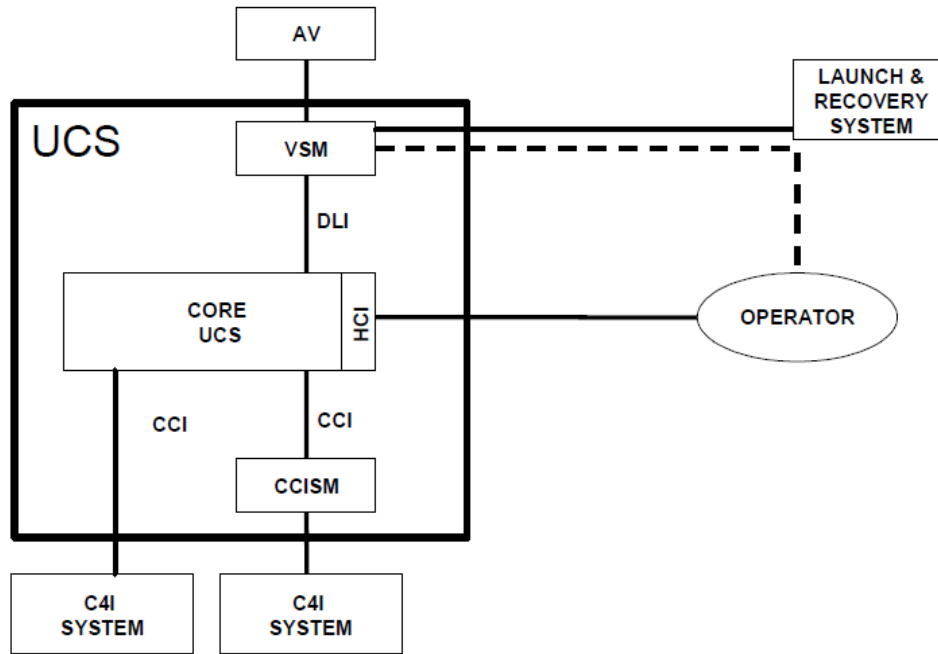

**Figure 6. UAS Physical Architecture as Defined by STANAG 4586**

*This diagram depicts the control station physical elements and interfaces as defined by STANAG 4586. Figure from [NATO, 2007].*

The fourth and final item of interest that STANAG 4586 addresses is a detailed definition of the three main GCS interfaces. The Data Link Interface (DLI), the Command and Control Interface (CCI) and the Human Computer Interface (HCI) are each detailed in separate appendices of the STANAG. The STANAG has grown in detail with each successive revision and update. Presently, the DLI and CCI are well documented in Edition 2 with the HCI in a lesser state of completion. It is expected that the HCI will be updated with the next edition as well as continually refined and clarified as required throughout the document.

The major take away from the STANAG is documentation of a common architecture and functional description of a UAS at a very high level. Additionally, the

document provides a detailed explanation of the major GCS interfaces. Having these items quantified and established in a solitary standard assists the UAS community by providing a single frame of reference and baseline to assist in system acquisition and development as well as operational usage.

As much as the STANAG has tried to facilitate interoperability within the UAS community, there are areas that are lacking which would be suitable for future updates or general knowledge when reviewing. First, being a NATO standard, there are limits to its applicability to non-NATO system development efforts. The U.S. DoD works with forces that are not necessarily part of NATO. True interoperability for the DoD is not just within itself and with NATO forces, but with all the forces that may come into coalition operations.

Second, while the STANAG tries to itemize each element of the Data Link Interface (DLI) and classify them as common messages, it also allows for *private* messages. Private messages allow for support of unique functionality. As industry develops more systems, there is a growing trend of more private message usage. As a result, manufactures can claim adherence to an open standard while simultaneously having significant reliance on the use of unique private messages.

Finally, another growing concern with usage of the STANAG is the evolving mandates for internet protocol based networked family of systems by the DoD. Whereas the STANAG looks to ensure interoperability by locking down configurations and strict adherence to interface definitions, the DoD is moving towards a networked and more loosely coupled family of systems approach. These approaches conflict with one another and the STANAG has not evolved to address this situation. In closing, while the STANAG has done a good job at fostering a method to achieve interoperability, there are areas that still need to be addressed as the pace of system development outpaces its ability to keep up.

**D. USD(AT&L) ADM 2009: UNMANNED AIRCRAFT SYSTEMS GROUND CONTROL STATION ACQUISITION DECISION MEMORANDUM**

On 11 February 2009, the USD(AT&L), Mr. John Young, issued the UAS GCS Acquisition Decision Memorandum (ADM) directing the Secretaries of the Army, Navy, and Air Force to develop plans to incorporate open architectures in the development of UAS GCSs. The direction provided in the memorandum was the result of an extensive program review of USAF and U.S. Army UAS GCS acquisition efforts. Mr. Young concluded that the acquisition community “has the opportunity to do something truly joint and powerful by adopting a common GCS architecture that is open and thus will allow for rapid addition of modular functionality” [USD(AT&L), 2009]. In addition to the warfighting flexibility that modular functionality allows, several other benefits of a common, open GCS architecture are discussed to include: innovation, competitive options, increased cost control, interoperability, efficient flow of data between stakeholders, reduced theater complications, training efficiencies, increased safety, and improvements in reliability and maintainability. All of these benefits have a direct correlation to reduced Life Cycle Costs (LCC) in the development, operation, and sustainment of UASs.

As discussed in the introduction, UAS GCS development to date has been characterized by proprietary systems and interfaces. This has hindered the ability of the services to adapt functionality to meet emerging requirements, and has made the interoperability between UASs virtually impossible. Proprietary development has also eliminated the possibility of introducing the benefits of competitive acquisition strategies to upgrade existing systems, which ultimately leads to higher costs to the government. The common, open systems architecture directed by USD(AT&L) is a complete change from these past practices. Open systems architectures that address all of the necessary GCS interfaces would allow the government greater flexibility with acquisition strategies. These open interfaces could be called out in future requirements documents allowing for greater interoperability and competition. Open systems architectures also beget innovation, as any corporation or government activity will have the opportunity to bring unique solutions to support the growth and sustainment of UASs.

Interoperability is a key focus of the ADM. Mr. Young points out that reduced theater complications can be achieved through a common GCS architecture. The ability to control tasking and receive data from cross-service UASs dramatically increases the effectiveness of the combatant commanders in conducting military operations. Currently, UASs are service unique, and data flow between differing operational nodes takes excessive time. As discussed, interoperability is different from commonality, and Mr. Young reinforces this concept in the ADM. The ADM does not direct that GCSs across all services be exactly the same (common), but rather the “flexibility to adapt the man-machine interface for specific Military Service’s Concept of Operations” [USD(AT&L), 2009] be achieved while the underlying architectures employ common components to the maximum extent possible. This allows the services to adapt human-machine interfaces that maximize performance based upon different operational scenarios while maintaining a common architecture and computing hardware. The common architecture and hardware reduce government acquisition costs and allow cross service maintenance and supply chain management for UASs.

The ADM also alludes to the dismal safety record of current UASs. Open, common GCS architectures will allow for increased training efficiencies for UAS operators and maintainers, and may improve the safety record described by the ADM. Much like the training pipeline for the Joint Primary Air Training System (JPATS) and Joint Strike Fighter (JSF) aircraft, UAS operators and maintainers across multiple services could receive training at the same location. This enables the potential for government cost savings in facilities and reduced development of service unique courseware. It also allows for mission flexibility, as there is the potential for cross service operation of UASs. Finally, it will increase the small pool of qualified UAS operators. Mr. Young also highlights that takeoff and landing is the most likely regime for a UAS mishap, and directs the services to consider the employment of autonomous control to reduce this occurrence. The ADM specifically tasks the USAF to incorporate this capability into its Predator and Reaper inventory.

To accomplish the objectives discussed, the service secretaries, in coordination with the UAS Task Force, are directed by the ADM to “initiate a joint effort to develop

and demonstrate a common, open, and scalable UAS architecture supporting Groups 2-5 UAS” [USD(AT&L), 2009]. Specific actions from USD(AT&L) include:

- Accelerate the fielding of Common Data Link (CDL) compliant communication systems
- Conduct a user assessment of the Sky Warrior One System GCS to evaluate aspects of functionality that could be applied to other GCSs
- Identify the lead service and management structure toward these efforts
- Develop a plan to conduct prototype demonstration with Predator, Reaper, and Sky Warrior UAS with Broad Area Maritime Surveillance (BAMS) and Global Hawk
- Develop competitive acquisition strategies for future GCS procurements

Finally, USD(AT&L) highlights the importance of these GCS efforts by ordering that any current UAS programs break out the GCS effort as a subprogram to increase oversight and visibility.

Since the release of the ADM the services have begun taking steps toward completing these tasks. Industry is also excited to participate in the growing UAS market, which is projected to be over \$62 billion over the next decade [Shalal-Esa, 2009]. Mr. Bigham, Director of Business Development for Raytheon Missile Systems, sees the ADM as a watershed event. “The fact that he forced everyone to use an open interface control document is the most important thing to happen in unmanned systems” [Warwick & Chavanne, 2009]. It is also recognized by USD(AT&L) that this effort will take several years. Mr. Weatherington, the Defense Department Deputy Director for Unmanned Warfare states, “Effectively transitioning from where we are today to where we need to be in the future will take time. Our strategy is to develop goals for the future architecture, then migrate legacy systems toward that architecture as they evolve. New systems would be required to adopt the new, common architecture” [Warwick & Chavanne, 2009].

The ADM is an important document that provides direction with regards to the need for commonality in UAS GCS development. This document, however, is not without its

shortcomings. First, the assertions in the document related to benefits that could be expected from achieving GCS commonality are in no way substantiated. These potential benefits are based on conventional notions about what improvements commonality can provide. Second, the extent of, and method for executing the commonality are not described. The ADM provides a goal without any specific guidance on how to achieve the goal.

#### **E. VARIATIONS OF GROUND CONTROL STATIONS**

GCSs can vary greatly in form and function. These differences can generally be tied to the size, mission, and cost of the UAS. Very small UASs, such as those produced by AeroVironment, can be controlled by a small device similar to a Personal Data Assistant (PDA) as shown in Figure 7. The slightly larger hand launched RQ-11B Raven can be controlled from a laptop sized device such as the one shown in Figure 8. Control of these smaller UASs is localized and many times can only be commanded through pre-programmed flight profiles or LOS communication. In contrast, the USAF Global Hawk is controlled from a deployable trailer, where there may be multiple operators manning several different stations as seen in Figure 9. These larger GCSs are capable of transmitting commands and receiving data over thousands of miles away via satellite communications. For these large systems, the GCS may not be co-located with the actual airfield that houses the air vehicle. For example, some large GCSs are located in the United States while the UAV is flying combat missions over the skies of Iraq or Afghanistan. In these cases the Launch Recovery Elements (LREs) are stationed at the air bases where the UAV takes-off and lands. The LRE has control over the UAV only during terminal control during launch and recovery, while the GCS conducts the transit and tactical portions of the UAV mission. Again, it is important to note that while it is called a ground control station, the control element itself could be onboard a ship, submarine, or manned aircraft.



**Figure 7. Small Handheld AeroVironment GCS**

*Small handheld devices, such as the one depicted above, can serve as the primary air vehicle control function for small UASs. Usually these smaller UASs are hand launched, and have an autopilot to land, reducing the necessary functionality of the operator interface. Figure from [AeroVironment Inc., 2009].*



**Figure 8. Small UAS Ground Control Station**

*The RQ-11B Raven can be controlled from a highly portable system. For these less complex UASs, a single operator may control all air vehicle functionality such as takeoff, executing the mission, and the recovery of the UAS. Figure from [Independent Defence Consultant, 2009].*



**Figure 9. Larger UAS Ground Control Station for Global Hawk**

*The Global Hawk Ground Control Station can be found in a trailer (as depicted above) or housed in a stationary building. There are several operator stations to execute a Global Hawk mission. It is likely that the picture above is during the transit phase of the mission, as the sensor operator stations are not manned. Figure from [Aviation Week, 2009].*

The Predator UAS has been in service for several years, and its GCS provides an example of the interface required to conduct air vehicle control tasks. The GCS for the Predator is shown in Figure 10. The Predator has a two-crew, side-by-side layout that allows the pilot and the sensor operator to share situational awareness across common screens. In this picture, the pilot is on the left, and the sensor operator is on the right, which is the standard setup for Predator and Reaper operations. The Predator GCS uses a joystick approach for UAV and sensor control, however there is a keyboard and trackball for some air vehicle control functions. The GCS also houses the radio contact between the Predator operators and the forward tactical air controller. These communications are accomplished through the headsets the operators are wearing. The pilot and the sensor operator have the ability to talk internally to each other and also to the air vehicle control element that is responsible for tasking airborne assets.



**Figure 10. Predator Ground Control Station**

*Inside a Predator ground control station at Creech Air Force Base showing commercial monitors and rack mounted militarized monitor. Figure from [IHS (Global) Limited, 2009].*

Figure 11 shows Raytheon's concept of a future GCS that could be used for Predator and other UASs. By optimizing the GCS layout there is the potential to reduce the number of operators that are required for each UAS.



**Figure 11. Raytheon's Universal Control Prototype Ground Control Station**

*Raytheon's concept for a GCS could be applied to several currently fielded and future UASs. Figure from [Defense Update, 2009].*

The Fire Scout is an unmanned helicopter that is currently in development. The relative size of the Fire Scout is similar to that of a Predator UAS. As such, the GCS, depicted in Figure 12, is founded upon the same design as the Predator. The Fire Scout GCS employs the same two-operator, side-by-side concept that is currently used by the Predator system. The Fire Scout is also being designed to have more autonomous operating capability than the Predator, which leads to a more streamlined control station design when compared to Predator. There is the possibility that as the system matures, the GCS may look more like the single operator Raytheon design as shown in Figure 11.



**Figure 12. Fire Scout GCS**

*The Fire Scout GCS is another side-by-side design where two operators control the air vehicle. Figure from [Globe Newswire Inc., 2009].*

## **F. SUMMARY OF BACKGROUND INFORMATION**

The OSD Roadmap, GAO, and USD(AT&L) all call for more commonality between both inter-service and intra-service GCS designs. This desire has been attributed to a need for more interoperability, greater ability to share tactical information, and a perceived reduction in LCC. These documents surmise that such goals could be met with

the use of modular, open source, standardized systems, but none of the documents offer any specific guidelines on implementation of these standards, or any means of mandating such actions across the DoD.

The STANAG is an attempt by NATO to document a common high level architecture and functional description of a UAS. Additionally, the document provides a detailed explanation of the major GCS interfaces. While this document is a step in the right direction, it does not offer enough detail to ensure interoperability among GCSs built according to its direction. Also, the current revision of the STANAG does not offer many guidelines related to human-machine interfaces, or an approach to their commonality.

A survey of current GCSs reinforces the lack of commonality across the DoD. Even UASs of similar sizes and missions utilize non-standard control systems that do not allow for commonality or interoperability.

THIS PAGE INTENTIONALLY LEFT BLANK

### **III. PROBLEM DEFINITION**

A review of the background information reveals a problem that requires further research about how to implement commonality and interoperability amongst the various GCSs. This project reviewed various aspects related to commonality and interoperability of UAS GCSs, and then scoped the efforts of the project related to this problem in Chapter IV.

#### **A. PROBLEM IN GENERAL**

The lack of: 1) common standards, 2) design for modularity, and 3) open system specifications has resulted in the problem of unique GCSs for UASs, increasing acquisition expenses, training requirements, and logistics footprints. The DoD has been directed to develop a plan to add commonality to UAS programs since the DoD cannot continue to develop, sustain, and operate UASs designed with stand-alone, propriety architectures. In the absence of any quantifiable evidence, former USD(AT&L) Mr. Young has stated, and the GAO has concluded, that a common GCS for UASs may yield cost savings benefits to the common logistics elements of training and maintenance. Additionally, operational effectiveness has been limited by the lack of interoperability in UAS GCSs. A push for greater commonality may encourage a higher level of interoperability for UASs.

#### **B. A DETAILED DISCUSSION OF COMMONALITY VERSUS INTEROPERABILITY**

In 2009, USD(AT&L) called for a “common, open and scalable UAS architecture.” GAO has stated, “common subsystems and components can reduce both production and life-cycle costs as well as improve interoperability” [GAO, 2009]. Open architectures are the next frontier in GCS procurement. “The new systems also are attempting to improve interoperability by conforming to open standards that facilitate communications with different types of aircraft” [Jean, 2009]. These statements imply commonality is a requirement for new UAS GCSs.

The second goal of the *Unmanned Systems Roadmap (2007–2032)* is to “emphasize commonality to achieve greater interoperability among system controls, communications, data products, and data links on unmanned systems” [OSD, 2007]. The *FY2009-2034 Unmanned Systems Integrated Roadmap* lists “greater interoperability among system controls, communications, data products, data links, and payloads/mission equipment packages on unmanned systems” as its fourth goal [OSD, 2009].

Merriam-Webster defines *commonality* as possession of shared features or attributes [Merriam-Webster, Inc., 2009]. The DoD defines it as “A quality that applies to materiel or systems: a. possessing like and interchangeable characteristics enabling each to be utilized, or operated and maintained, by personnel trained on the others without additional specialized training; b. having interchangeable repair parts and/or components; and c. applying to consumable items interchangeably equivalent without adjustment” [Joint Chiefs of Staff (JCS), 2009].

Merriam-Webster defines *interoperability* as the ability of a system to work with or use the parts or equipment of another system [Merriam-Webster, Inc., 2009]. The DoD defines interoperability as the “a. The ability to operate in synergy in the execution of assigned tasks. b. (DoD only) The condition achieved among communications-electronics systems or items of communications-electronics equipment when information or services can be exchanged directly and satisfactorily between them and/or their users. The degree of interoperability should be defined when referring to specific cases” [JCS, 2009].

Interoperability can be achieved without commonality. For example, a DoN aircraft flying with an AN/ARC-210 radio can communicate with U.S. Marines operating AN/PRC-117 radios and with ships using AN/WSC-5 radios. Although each operator has a different radio made by different vendors, they can all communicate through Ultra High Frequency (UHF) Satellite Communication (SATCOM). In a similar manner, different UASs could achieve interoperability by using similar languages to share data with one another, such as the Common Data Link (CDL) or the Tactical Common Data Link (TCDL).

Commonality can also be achieved independent of interoperability. Use of the same display or joystick in different GCSs, for example, would provide commonality from a hardware perspective. Advantages of this level of commonality include the economy of scale and the reduced logistics footprint of a singular component. This type of commonality would not improve interoperability.

STANAG 4586 defines five LOIs for UASs. It goes on to say that maximum operational flexibility can be achieved if the GCS supports these LOIs with different UAVs. Definitions of these LOIs can be found in Table 1. Figure 13 illustrates the perspectives of these LOIs. As shown, Level 1 can be achieved through the use of common or compatible file transfer protocols and message or imagery formats.

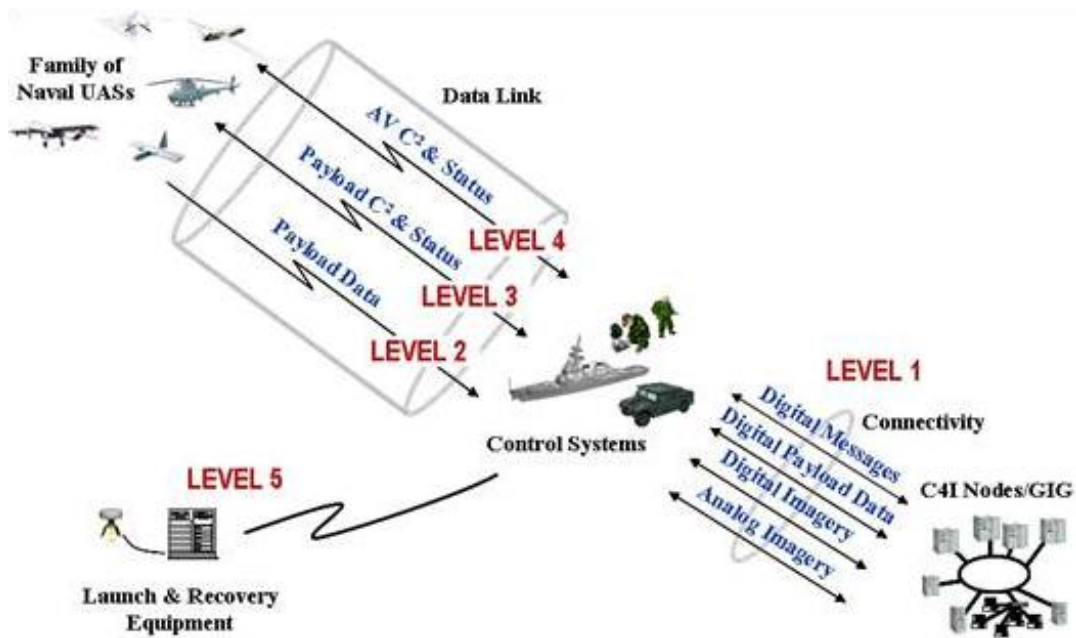

**Figure 13. Level of Interoperability Perspective**

*This figure illustrates the relationships of the five LOIs as outlined in STANAG 4586. These levels vary from the lowest interoperability level of 1, where two-way communication between the GCS and the GIG allow sharing of payload data, to the highest interoperability level of 5, where a GCS would be capable of launch and recovery of multiple UAVs. Figure from [PEO(U&W), 2009].*

STANAG 7085 *Interoperable Data Links for Imaging Systems* outlines the requirements for Level 1 interoperability compliance. It defines interoperable interfaces for UAV sensors as well as compliant data link and communications protocols [NATO,

2004]. The DoD has adopted the CDL and TCDL for sharing sensor data across the Global Information Grid (GIG). Use of these links should ensure that UASs meets Level 1 interoperability. This should enable more forces to receive sensor data from compliant UASs.

Level 1 interoperability would be a good starting requirement for all UASs. Sharing sensor data is necessary to let forces operating in the area with the UAS make decisions quickly. This sensor data can also be used by military commanders to make decisions regarding close air support and time sensitive targets. Level 1 interoperability allows decision makers to have more data to support their decision. However, indirect sharing of data takes time and requires others to process and relay the sensor data. Level 2 would allow direct sharing of sensor data with those in direct communication with the UAS. This direct link is illustrated by the one-way arrow from the air vehicle to the ship. Payload data is sent directly to the receiving entity. Level 3 would allow any GCS in direct communication with the UAS to control the sensor, aim the cameras or identify a target location. The two-way arrow indicates the commands to control the sensor and the data transmitted in response. Level 4 allows for control of the air vehicle itself. Again a two-way arrow indicates that commands are sent to the air vehicle and status updates are returned to the operator. For a GCS to control both the sensor and the vehicle, it must be Level 3 and Level 4 interoperable [NATO, 2007]. Level 4 interoperability does not implicitly include Levels 1 through 3.

For Level 2 through Level 5, the tenets of STANAG 4586 apply. This document calls for the implementation of standard interfaces to allow a GCS the flexibility to communicate with various UAVs. The use of standard interfaces could also facilitate the integration of common components from various sources into the GCS. This would foster competition and creativity in the development of components and modules for use in GCSs.

The One System Ground Control Station (OSGCS), built by AAI, is an example of a common GCS. The OSGCS, shown in Figure 14, is currently used by the U.S. Army and U.S. Marine Corps on the Shadow, Hunter, Pioneer, Raven, Predator and Sky

Warrior platforms [AAI Corp., 2009]. The OSGCS has achieved interoperability through commonality. The same control station, with common hardware and human interface, is used by different air vehicles.



**Figure 14. The One System Ground Control Station**

*This figure shows the OSGCS installed in a mobile vehicle (left) and a closer view of this system in operation (right). The OSGCS is an example of an attempted common ground system. Figure from [AAI Corp., 2009].*

The DoD could mandate that all UASs utilize the OSGCS. This would provide many advantages. All UAS operators and maintainers trained on the common OSGCS would be able to work with any UAS. One supply system may be able to support all UAS GCSs, reducing the logistics footprint. On the other hand, mandating the use of the OSGCS would create a monopoly. Competition and innovation would be stifled. In the long term, the DoD could end up overpaying for outdated technology as no incentives would exist to constantly improve the OSGCS.

An open-source GCS could be developed as a *one-size-fits-all* GCS. The OSGCS could be a model for such a system, but this system should be open for multiple vendors to compete to support the entire system or components of the system. This would allow the advantages of commonality while encouraging competition and innovation.

The disadvantage of a *one-size-fits-all* approach to UAS GCS is the tradeoffs that must be made. If every UAS needed to use the GCS, then it would optimize a common solution to all UAS needs. No individual system would be optimized, as compromises

would need to be agreed to by all programs. In the same manner that manned aircraft have differences, UASs may have enough differences to make a single system an unacceptable solution.

A common GCS could allow the operator to control those functions of interoperable air vehicles that are deemed as common functions. Table 2 shows common functions as well as vehicle or payload specific functions as defined by STANAG 4586. Control of common functions could be allocated to a common GCS or an LOI of 4 could be the benchmark, allowing the use of compliant GCSs to control compliant air vehicles.

**Table 2. Common versus Vehicle-Specific Functions of UAS**

*This table lists UAS functions that are typically considered common to all UAS as well as those considered to be functionally specific based on the phase of the UAS mission. Table from [NATO, 2007].*

| <b>Mission Phase</b>             | <b>Common Functions</b>   | <b>Vehicle-Specific Functions</b>  |
|----------------------------------|---|--|
| Pre-flight                       | Interoperable Mission Planning<br>Mission Plan / Verify Upload Process.<br>Common Built-In-Testing (BIT).<br>Mission Go / No-go   | Vehicle Availability.<br>Flight Plan Validation.<br>Lost Link Strategy.<br>Vehicle Specific BIT.<br>Payload Configuration Validation & BIT checks.<br>Pre-flight Checkout and Initialisation.<br>Downloaded Mission Plan Validation.<br>UCS/Vehicle Communications.<br>Clocks Synchronization (Air Vehicle & UCS). |
| Takeoff                          | Local ATC Communications.<br>Checklists Complete Validation.<br>UCS/UAV Communications Validation.<br>Takeoff Clearance Acquisition.  | Ground Traffic Pattern/Plan Execution.<br>Ground Operations Safety Constraints Monitoring.<br>Launch.<br>Abort Sequence Management.  |
| Ingress / Egress                 | Mission Execution Monitoring.<br>Active Emitters (e.g., radar) Activation.  | UAV Vehicle-Specific Handoff Data Management.  |
| Prime Mission Area (Target Area) | Generic Payload Control.<br>Payload Data Handling.<br>Mission Execution Monitoring.<br>System Status Summary Information.   | Detailed System Status Monitoring.<br>Payload Specific Control & Monitoring.<br>Payload Specific Data Handling   |
| Approach / Landing               | ATC Coordination.<br>Recovery Procedures Execution.   | Approach Flight path Acquisition and Maintenance.<br>Landing Sequences Execution.<br>Taxi Sequence Execution.<br>Shutdown / Safing Checklists & Procedure Execution.   |
| Post-Mission Reporting           | Mission Execution Summary Report.   | Vehicle Maintenance Status Report.   |
| Phase-independent In-flight      | UAV handoff among UCSs Management.<br>Mission Execution Monitoring.<br>Mission Phase Monitoring.<br>General Health & Status Monitoring (H&SM) and Warning.<br>Dynamic Flight Path Replanning.<br>Multiple (Possibly Different) Aircraft Control.<br>Data Recording / Buffering.<br>GDT Control, Status, & Initialisation. | Detailed Health & Status Monitoring.<br>Lost Link Strategy Execution and Monitoring.<br>Operator Control Modes Management.<br>CBIT (Continuous Built-In-Tests) Across Subsystems.<br>Differential GPS Corrections.   |

Commonality requirements could be achieved by implementing a common subsystem. If GCSs used the same display subsystem, commonality would be improved. However, interoperability of these GCSs would not change. Using a single-source proprietary display could result in a monopoly, and the idea of effective use of acquisition resources may not be realized.

Interoperability could be achieved without commonality. If interoperability is indeed the driver for the memo from USD(AT&L), then commonality may not be required. However interchangeable parts, components, or subsystems could enable interoperability of systems. Moreover commonality in GCSs could reduce the duplication of efforts in development. It could also lead to an economy of scale through larger production runs of common components and systems.

### **C. ELEMENTS INFLUENCING COMMONALITY AND INTEROPERABILITY**

In order to better understand the problem, a number of elements influencing commonality and interoperability in UAS GCSs were identified. These elements are considered to have significant roles in the ability to achieve commonality and interoperability in GCSs. Once the elements were adequately explored, the list was scoped down in Chapter IV for further analysis in the latter portions of the report.

#### ***1. Airframe Size and Groupings***

UASs are currently categorized into five groupings per the Joint UAS (JUAS) Center of Excellence (COE) [JCS, 2006]. These groupings are based on weight, operating altitude, and speed of the air vehicle. Group 1 UASs are relatively small systems that operate at lower altitudes and slower airspeeds than other groups. Group 1 systems are usually operated directly by the unit that requires the video or imagery. Group 2 systems are heavier, operate at altitudes higher than Group 1, and have payloads that are more capable. Group 3 systems are even heavier, up to 1320 pounds, and can operate up to 18,000 feet Mean Sea Level (MSL). Group 4 systems weigh more than 1320 pounds, and fly up to 18,000 feet MSL. Group 5 UASs fly above 18,000 feet

[USMC Combat Development Command, 2009]. Table 3 shows this data in a tabular form.

**Table 3. UAS Categorization in Groups**

*This table shows the UAS category based on speed, weight and altitude. Group 1 includes the small handheld UASs, while Group 5 includes the large high-altitude UASs. Table after [USMC Combat Development Command, 2009].*

| <b>UAS Category</b> | <b>Maximum Gross Takeoff Weight (lbs)</b> | <b>Normal Operating Altitude (ft)</b> | <b>Speed (KIAS)</b> | <b>Representative UASs</b>  |
|---------------------|---|---------------------------------------|---------------------|---|
| <b>Group 1</b>      | 0-20                                      | < 1200 AGL                            | 100                 | WASP III, TACMAV, RQ-14A/B, BUSTER, BATCAM, RQ-11B, FPASS, RQ-16A, Pointer, Aqua/Terra Puma |
| <b>Group 2</b>      | 21-55                                     | < 3500 AGL                            | < 250               | ScanEagle, Silver Fox, Aerosonde  |
| <b>Group 3</b>      | < 1320                                    | < 18,000 MSL                          |                     | STUAS, RQ-7B, RQ-15, XPV-1, XPV-2   |
| <b>Group 4</b>      | > 1320                                    |                                       | > 18,000 MSL        | Any Airspeed  |
| <b>Group 5</b>      |   | UCAS, MQ-9A, RQ-4, RQ-4N              |                     |   |

Group 1 UASs are often launched by hand or rail and operate LOS with the unit that launched it. Figure 8 shows an example of a GCS for this type of UAS. This particular GCS can operate a Raven or Wasp UAS. Group 1 UASs benefit from a handheld GCS. Such a system enables a unit to carry both the air vehicle and the GCS along until the system needs to be deployed. If a larger, common GCS were mandated, it could reduce the mobility of the unit and increase its chance of detection. It would also increase the manpower requirements of the handheld UAS. For example, a vehicle installed GCS may be overkill for Group 1 UASs. The benefits of commonality may well be offset by the reduced capabilities that were originally designed into these smaller systems.

Larger UASs, especially those in Groups 4 and 5, are able to operate in both LOS and OTH modes of communication. Because of the air vehicle size and payload capabilities, larger vehicles often require both a remote pilot and a sensor operator. Chapter II.E shows some examples of larger UAS GCSs. Such GCSs are not man-portable. They are installed in either a vehicle or a structure. These systems are envisioned to be in operation for many years. They also carry larger LCC than those in Group 1. Small gains in efficiencies or small reductions in costs could translate to large benefits if commonality and interoperability are applied to the large UASs.

Requiring a common GCS to operate with all UASs, regardless of size or grouping, may be counter-productive. The requirements and capabilities of a Group 5 UAS will dictate a GCS with greater capabilities than a Group 2 UAS. For this reason, a Group 5 GCS will have extra features that a Group 2 GCS does not require. UAS capabilities should be considered along with the potential benefits of commonality. Commonality involves compromise, and what works for a Group 2 UAS may provide insufficient capability for a Group 5 UAS.

## **2. *Air Vehicle Control versus Mission Specific Payload Control***

As identified in STANAG 4586, discussed in Chapter II.C, each UAS has five distinct elements: the air vehicle element, the payload element, the data link element, the GCS element, and the launch and recovery element. Three of these five elements address air vehicle functions. These are the air vehicle element, the payload element, and the launch and recovery element. This section addresses how commonality may affect control of the air vehicle portion of the UAS, including the launch and recovery element and the payload element.

The air vehicle control element can be impacted by commonality through identifying common or standard interfaces between the air vehicle and the GCS. This will also lead to increased interoperability. The payload element can be impacted by commonality in the same way. The most direct element that could be common that would impact both the air vehicle control and the payload element is the data link element. It would require both the air vehicle control and the payload element to utilize

message traffic that has been standardized. However, this common standardization may require additional hardware and software on the GCS and the air vehicle to be able to convert it to and from the common message traffic. Standardized message traffic has been identified in STANAG 4586. STANAG 4586 contains appendices that address standards for interoperability. One addresses the Data Link Interface (DLI) and the other addresses the Command and Control Interface (CCI). The standardization of the CCI is intended to achieve interoperability between the UAS and the C4I users. There is no standardization to allow mission specific payload message traffic to be interoperable, so there is less leverage for commonality from a mission payload standpoint. Commonality could be leveraged to achieve interoperable CCI.

The 2003 NDIA report identified issues for the air vehicle control interfaces that currently exist with respect to commonality:

- UAV CONOPS are inconsistent in their approach to AV C2 interfaces
- No formalized C2 specific requirements
- UAV manufacturers have proprietary data concerns
- Compatibility with external interfaces has not been established
- Adaptability to future systems is not embedded
- Backward-compatibility has not been addressed
- C2 interface training is different for each UAV

For current UASs, the air vehicle control interface is exclusively located at the GCS for each system. Therefore, these challenges must be addressed in the GCS design.

The 2003 NDIA report also identified the following issues for the mission specific payload interfaces that currently exist with respect to commonality:

- Payload controllers see only their payloads
- Imagery products use common standards, most other information exchange is non-standard

- Mechanism for communicating with payloads is unique for almost all existing platforms
- Payload contention for vehicle control addressed by human operators
- Information assurance limited to encryption and human judgment
- Bandwidth issues are generally static
- Any platform-platform interactions within constraints imposed by the communications links, doctrine, and CONOPS are human-mediated

The report specifically identifies that “Tasking is disjoint for all payloads. There is no standard method...for making generic requests for information” [NDIA, 2003].

While there are many benefits that can be achieved with commonality in the air vehicle control and mission specific payload domains, there are still many challenges associated with each respective domain. However, based upon the current standardization that has already been addressed with the STANAG 4586, it is anticipated that the air vehicle control interface is more likely to benefit from commonality efforts at this time.

### ***3. Human-Machine Interface***

The Human-Machine Interface (HMI) for UASs consists of the controls and displays that the operators use to interact with the system. Controls and displays with a common functional and physical architecture provide progress towards meeting the tenets of the ADM. “We can provide flexibility to adapt the man-machine interface for specific Military Service’s Concepts of Operations while maintaining commonality on the underlying architecture and computing hardware....These improvements can also reduce training requirements, decrease training time, and increase the pool of UAS pilots/operators” [USD(AT&L), 2009].

Some UASs may not be a good candidate for common GCS controls and displays. For instance, small hand-launched UAVs may require a simple handheld remote controller and a laptop computer for sensor display. It is unlikely that the WASP (0.7 pounds) controls and displays would provide the required functionality for BAMS

(32,000 pounds). Additionally, fixed wing UAS controls may not work for rotary winged UASs.

Controls may consist of a joystick, keyboard, mouse, trackball, and in some cases foot pedals and throttles. All of these controls may not be required and are dependent upon the UAS mission and type. All GCSs pass commands to UAVs via one of two different methods. The first method is the legacy *controlled* technique where a pilot makes control corrections on a throttle and joystick and these control positions are transmitted to the UAV and provided as the inputs to the UAV flight control surfaces. The second method is the newer *directed* technique where a waypoint is transmitted to the UAV and the onboard flight control computer determines and commands the control surface changes necessary for the UAV to intercept the waypoint. UAVs that are directed, vice controlled, do not have a joystick or foot pedals. This leads to the conclusion that all GCS controls may not be able to be common. For example, some UAVs can be commanded by remote control type controllers, as shown in Figure 15. This type of specialty control may not be a good candidate for a common control and would only work for specific UAVs. Additionally, control inputs for directed UAVs could be accepted from touch screen displays, blurring the line between controls and displays.



**Figure 15. Remote Control used on British Army Hermes 450 UAV GCS**

*The red circle highlights a remote control type controller such as could be used to control a model airplane. This is one type of control that is present in some unmanned systems. Figure after [IHS (Global) Limited, 2009].*

As discussed, there are currently different methods of implementing the pilot HMI. Some GCSs, such as that of Predator and Reaper, have a controlling type pilot interface. That is, the interface is designed to give the air vehicle operator the feel and display of being in a cockpit. The air vehicle is issued commands through a stick and throttle system actually sending flight system controls to pitch, roll, and yaw the aircraft like a pilot would in a cockpit of a traditional aircraft. A visual display, such as in General Atomics' new Advanced Cockpit Ground Control System, "expands the operators' field of view to 120 degrees from 30 degrees with a panoramic synthetic view generated by software from a military mapping server," simulating the view a pilot would see out the cockpit window if the operator was there [Jean, 2009]. Similarly, Raytheon Corporations' new Common Ground Control System is "laid out in a cockpit-like

configuration” and “three wide-screen displays give pilots and sensor operators a 120-degree view of the battlefield” [Jean, 2009].

As previously mentioned, a completely different type of HMI for UAVs is command by direction, which is currently used by the USAF Global Hawk and planned in the USN BAMS UAS. This newer *directed* method of command input allows the user to set desired states of the aircraft, such as altitude, course, and airspeed. It is more likened to flying the UAS through an autopilot. Whereas in a *controlled* type interface, the pilot pulls the stick back to gain altitude and then pushes it forward to level off, in a *directed* type interface, the pilot simply sets the desired altitude, sends the command to the UAV and the vehicle computes all the inputs to the control surfaces including rates, and maneuvers itself to get to the desired altitude. This allows less hands-on control and more monitoring and usually allows the user to set waypoints (positions in 3-D space) that the air vehicle will fly to as a course.

Another area that is different between the two types of systems is in the terminal area (the phase of flight near the ground, both takeoff and landing). A controlled UAV uses GCS stick-and-rudder commands to takeoff and land and usually provides pilots with a camera view of the runway in front of them to takeoff and land manually. A directed type system will direct the UAV to the runway, and once there, issue a takeoff command, where the UAV will do all of its own control adjustments to maintain its pre-planned takeoff route while the pilot monitors its progress. These are two dramatically different approaches to the takeoff and landing phases of flight.

The DoN is going down the path of a directed point-and-click interface. RDML William Shannon, Program Executive Office Unmanned Aviation and Strike Weapons (PEO(U&W)) noted, “When you say GCS, many folks picture a piece of hardware. For the USAF, it really is a cockpit on the ground. But we don’t fly our UASs. None that we have or are planning have any stick-and-rudder type of flight-it's preplanned or point and click” [Warwick & Chavanne, 2009]. As this report examines areas of commonality across UASs, the GCS operating system will be a key element. RDML Shannon highlights the DoN philosophy on GCSs: “Really, it ought to be thought of as a software

application that can operate on any platform, from consoles to handhelds. This thing we call a GCS is really a GCS application you'd be able to employ on multiple hardware platforms. That's where we'd like to go" [Warwick & Chavanne, 2009].

When it comes to displays, an example of a GCS using commercial, militarized, and rack mounted displays is shown in Figure 16. The standard commercial displays are highlighted with a red border. The militarized and rack mounted displays consist of two larger displays, one over the other, and two smaller displays shown side by side. This demonstrates a lack of hardware commonality in that even within a single GCS, the operator can use three different display types.



**Figure 16. Predator Ground Control Station**

*Inside a Predator ground control station at Creech Air Force Base showing commercial monitors and rack mounted militarized monitor. Figure after [IHS (Global) Limited, 2009].*

Another HMI consideration is the way data is displayed to the operator. Displayed data can conform to the common symbology contained in MIL-STD-2525C: *Common Warfighting Symbology* [DoD, 2008]. One of the problems with MIL-STD-2525C is that it was originally published in 1994 and was designed for older displays with low resolutions. The updates to the standard have not kept pace with the

technological advances realized by newer high definition displays. Using a common symbology can enhance training commonality between different UASs. An example of common symbology from MIL-STD-2525C is shown in Figure 17.

| BATTLE DIMENSION<br>STANDARD IDENTITY | ABOVE SURFACE |           |         | SURFACE    |           |               |                 |                |         |
|---------------------------------------|---------------|-----------|---------|------------|-----------|---------------|-----------------|----------------|---------|
|                                       | Unknown (Z)   | Space (P) | Air (A) | Ground (G) |           |               | Sea Surface (S) | Subsurface (U) | SOF (F) |
|                                       |               |           |         | Units      | Equipment | Installations |                 |                |         |
| PENDING (P)<br>(YELLOW)               |               |           |         |            |           |               |                 |                |         |
| UNKNOWN (U)<br>(YELLOW)               |               |           |         |            |           |               |                 |                |         |
| FRIEND (F)<br>(CYAN)                  |               |           |         |            |           |               |                 |                |         |
| NEUTRAL (N)<br>(GREEN)                |               |           |         |            |           |               |                 |                |         |
| HOSTILE (H)<br>(RED)                  |               |           |         |            |           |               |                 |                |         |
| ASSUMED FRIEND (A)<br>(CYAN)          |               |           |         |            |           |               |                 |                |         |
| SUSPECT (S)<br>(RED)                  |               |           |         |            |           |               |                 |                |         |

**Figure 17. Examples of Common Symbology**

*This graphic shows standard identities for common sensor contacts. Red denotes hostile or suspect, yellow denotes pending or unknown, blue is friend and green is neutral. Figure from [DoD, 2008].*

Additional considerations when discussing common HMI for GCSs include nonstandard control and display solutions such as Helmet Mounted Displays (HMDs). HMDs were considered by the DoD and quickly discounted due to the added complexity and the likelihood for motion sickness, eye strain, and disorientation. This was determined during a 2004 experiment at the Ames Research Center, Moffett Field, CA, which evaluated UAV operators wearing an HMD versus using a conventional computer joystick to perform sensor target search tasks. “The subjects’ ability to place the cursor on a target of interest (targeting accuracy) was significantly better in the computer

monitor condition than the HMD. The distance at which subjects could classify an object's identity was also significantly better in the computer monitor condition. Subjective measures showed no overall differences for self-reported fatigue, workload, and situational awareness. A significant disadvantage, however, was found for the HMD with respect to self-reported nausea, disorientation, and oculomotor strain" [Morphew, Shively, and Casey, 2004].

The previously mentioned HMI considerations must be taken into account when discussing a common UAS GCS. Many of the variations in HMI aspects of GCSs manifest themselves as challenges when looking for a common interface.

#### **4. *Hardware and Software Combination***

The GAO report titled *Improved Strategic and Acquisition Planning Can Help Address Emerging Challenges* cites:

The services have generally been reluctant to adopt common mission management systems or other interoperability approaches within similar types or classes of UAVs. As a result, it appears that some UAVs may not be fully interoperable with other UAVs, with manned aircraft systems, or even with conventional forces. For example, in certain instances ground forces have not been linked to or able to utilize data generated by other services' UAVs. Each service has tended to initiate its own separate development program, specifically tailored to its own requirements, rather than adopting an existing capability from another service. The DoD is aware of this problem and has taken some steps to address it. For example, the DoD is evaluating several areas, including vehicle development, training, and data sharing, to determine if improvements in these areas will increase UAV interoperability. [GAO, March 2005]

While vehicle development, training, and data sharing are being addressed to determine if improvements in these areas will increase UAV interoperability, it is evident that the DoD will need to evaluate the hardware and software combinations to achieve that goal. However, a challenge for common hardware or software for the DoD is a result of unique requirements for each service.

The Joint Unmanned Combat Air Systems (JUCAS) program was initiated as a USAF and USN program for attack of land targets:

Concerned about the accelerated schedule and a lack of synergy in the separate Air Force and Navy efforts, Office of the Secretary of Defense officials intervened to reconcile requirements and funding challenges and to improve oversight. The Defense Advanced Research Projects Agency was designated to lead the joint demonstration program with Air Force and Navy participation. Plans and strategy established a \$4 billion demonstration program that would develop larger versions of the Air Force and Navy prototypes, leading to an operational assessment in 2007. A common operating system was to be developed and both versions were expected to also share common subsystems and weapons. The intent was to then offer alternatives to the services leading to possible start-up of systems development in 2010. Although not clear at this time <2005>, program direction and content appears to be again changing. Congress reduced fiscal year 2005 funding, stating that the program had not properly coordinated with the services and that the focus should be on meeting Air Force and Navy requirements. [GAO, March 2005]

Even with a proposed common operating system, the services found their respective requirements were not being met. The USAF pulled out of the program and “redirected its development efforts towards a larger, stealthy high-altitude unmanned platform.” The USN decided to “continue with a more ‘traditional’ Unmanned Combat Air System (UCAS) design” [Hewson, 2006]. Even when common hardware and software are products of a program, the services find they do not meet their requirements.

A 2003 NDIA common UAV architecture study analyzed this problem and identified some challenges associated with commonality. For the processor architecture, the NDIA identified the following issues with respect to commonality:

- Few common operational interfaces
- No universal conversion standards
- Little backward-compatibility except within family
- No multi-level security
- Little common software
- Few universal external interfaces

These issues, whether or not they were allocated to software or hardware, would need to be addressed in order to achieve commonality. The report recommended “developing

hardware independent software using open hardware/software architectures, standards and COTS products” [NDIA, 2003].

Discussions of a common or interoperable GCS must take into consideration the manifestation of the commonality. Decisions must be made whether hardware commonality, software commonality, or both are required to achieve the goals of the DoD.

### ***5. Implementation through Retrofit or New Acquisition***

To maximize acquisition resources and meet increased demand, Congress and the DoD have required more commonality among UASs. GAO has recommended “that before initiating new unmanned aircraft development programs, the Secretary should require the services to demonstrate in their acquisition plans and strategies that they are taking an open systems approach and that the potential for commonality has been rigorously examined” [GAO, 2009]. Therefore it is assumed that future development will be required to meet some minimum level of commonality and interoperability.

As common components and subsystems transition from development into production, new UAS programs should require their incorporation. The use of off-the-shelf and non-development items should be required as well. Initial engineering development models should be delivered with common components and tested for performance and interoperability [Van Dyke, 1990]. In this manner future UAS GCSs can be designed for commonality.

Many options exist for those GCSs already fielded and operational. Forced retrofit, requiring all GCSs to adopt the common components or systems, would be the most extreme option. Block upgrades could be conducted, taking smaller groups of GCSs and upgrading them to the new common design. Individual GCSs could be made common by attrition. In this case, as systems fail, they could be reconfigured to a common system. Introduction of common components and modules into the supply system would be another method of achieving commonality by attrition. As individual components fail, common components and subsystems could be identified as preferred

spare parts for replacement. Finally, there is the option to do nothing with systems that are already fielded and focus solely on new acquisition. Systems already fielded or far enough in development may be left as-is until their retirement due to unplanned cost increases.

As stated, forced retrofit would be the most extreme option. It would ensure the maximum level of interoperability in the minimum time. The benefits of commonality or interoperability may not be sufficient to offset the cost of a forced retrofit. Negative transfer on such systems could also be expected.

Negative transfer occurs when training on one system interferes with the learning of another. Habits in a legacy UAS could be applied to the new system. Personnel who operated legacy GCSs could be expected to rely on years of experience with those systems, even if that experience was no longer relevant after the retrofit. This situation is worst when displays and interfaces between the two are similar, and when similar actions on the legacy system have very different consequences in the new one [Lydall & Wickens, 2005].

At the first opportunity, modifying GCSs during scheduled or unscheduled maintenance would eventually achieve commonality over time. Often this is the DoD's preferred method of implementing change because of its low cost and the timing of modifications [Crowder, 1992].

Modification by attrition would take an even longer time to fully implement compared to first opportunity. Only when systems or components fail would they be modified to a more common configuration. Systems or components with high reliability may take years to fail. However, the impact to the end user is minimal. Only when the system has a failure, and is thus already non-operational, is it taken off-line for modification.

Modification by attrition or first opportunity may increase the risk of negative transfer. Since systems are not all changed at once, it is possible for an operator or maintainer to work on one configuration one day, and another soon after. Training in the

new configuration would be required, and human error could increase as personnel rely on the way they initially learned the system.

UAS programs already in development have spent large amounts of money developing GCSs with more under contract. Major changes to these GCSs may carry a large price tag. It may be more beneficial to finish these systems and leverage lessons learned from legacy and new systems. On the other hand, the number of proprietary GCSs continues to grow. With no concern for commonality, the problem will only get worse. Directives are in place and the services need to respond. Doing nothing is not an acceptable option.

#### **6. *Department of Defense Multiservice Cooperation***

As stated within *FY2009-2034 Unmanned Systems Integrated Roadmap*, "...the Roadmap lays out a vision in terms of potential missions that could be performed by unmanned systems, the desired functionality and performance needed by the systems to perform those missions, and the technology advancements needed to achieve such performance" [OSD, 2009]. It is in this document that the Office the Secretary of Defense's vision is communicated for UASs. This vision addresses the following areas [OSD, 2007]:

- Conducting a more integrated approach to identifying how unmanned systems can be optimized to support a greater set of mission areas
- Identifying those common areas of technology maturation that can lead to performance improvements in all domains
- Identifying the technology enablers needed to foster the ability to conduct collaborative operations between multiple unmanned systems in multiple domains

Areas well suited for commonality will be investigated as a candidate for implementation. By identifying those common technology areas for the common GCS, a more integrated approach to supporting a greater set of mission areas can be achieved.

As the OSD Roadmap states, UASs can perform persistent Intelligence, Surveillance, and Reconnaissance (ISR), a capability that fleet commanders have never

had before. “They can be rapidly and dynamically re-tasked to other areas with a higher priority, and are currently enjoying tremendous freedom of action in uncontested airspace. Because of this, UASs are proliferating throughout the theater of operations supporting both the JFC and ground combatant commanders. To shape their battle space and make decisions affecting the outcome of their engagements, commanders at all levels require situational understanding and UASs can provide a variety of these components. They increase the situational awareness (SA) of commanders through intelligence, surveillance, reconnaissance, and target acquisition” [OSD, 2009].

However, all DoD services do not utilize UASs in the same manner. Each service will employ a UAS to meet its specific operational needs. “All four Services employ multiple UASs for a variety of tasks and missions including fleet, perimeter security, tactical surveillance, weapons spotting, targeting, and weapons guidance, as well as a host of other unit mission-specific tasks” [OSD, 2009]. Although there are similar UASs across the DoD, each service will utilize their UASs in a unique manner to meet their specific operational needs. This lack of a common joint operational concept is one of the challenges of creating a common UAS GCS.

The NDIA 2003 report that presented challenges with commonality also identified CONOPS as an issue associated with commonality across the DoD services. “There are no inherent forces driving towards Concept of Operations (CONOPS) commonality....Operators will employ the delivered capabilities of each system to meet their training and warfighting requirements, and while similarities will be apparent, there is no driving need for CONOPS commonality across inherently different systems” [NDIA, 2003]. Although some DoD groups have been working toward a common UAS CONOPS since the NDIA report was released in 2003, all the services must agree and adhere to these CONOPS before true commonality can ensue. A specific example of the commonality challenge across the DoD services is the Predator and Sky Warrior case presented in Chapter I.C.

## 7. *United States and Allied Cooperation*

NATO UAS operations originated during the mid-1990s. “Unmanned aircraft presence in the Balkans theater of operations dates back to 1994. In 1995, U.S. Predators flew operationally for the first time over Bosnia. In October and November of 1998 U.S. Air Force RQ-1 Predators flying from Hungary supported the Organization for Security and Cooperation in Europe (OSCE) verification mission over Kosovo. The German Army followed with CL-289 drones, based in Macedonia. Soon afterwards several other NATO countries deployed their own assets” [Saiz & Lewandowski, 2008].

“Efficient utilization of the capabilities provided by the different unmanned systems proved to be challenging with, in some instances, a tendency for micromanagement by senior commanders. Every single unmanned mission over the Balkans had to be included in the daily Air Tasking Order (ATO) with the consequent difficulties of coordination. Another important obstacle to overcome was de-confliction. The situation got even more complicated after the deployment of KFOR and the increased helicopter and air transport activities” [Saiz & Lewandowski, 2008].

Currently, interoperability between UASs within a single nation does not exist, let alone interoperability between multinational UASs. “In an attempt to address the problem of interoperability between nodes in a multinational UAV network, the NATO STANAG 4586 was created to address standard interfaces of UAV control systems. In its second edition, STANAG 4586 was conceptualized to promote interoperability between one or more control stations, UAVs and their payloads, and the C4I network, particularly in joint operational settings. STANAG 4586 attempts to accomplish this through implementing ‘standard interfaces’, which should not be confused with HCI. The standard interfaces are essentially communication message sets between the vehicle and a control station” [Cummings, Kirschbaum, Sulmistras, and Platts, 2006].

The need for UAS interoperability among NATO Alliance members is understood and accepted. The implementation of this standard has begun. “Several vehicles have flown using STANAG software hosted on the Common Data Link (CDL) Systems Vehicle Control Station, including Silver Fox (Advanced Ceramics Research),

Grasshopper (Xiphos), Warrior - Extended Range/Multi-Purpose (ER/MP) (General Atomics Aeronautical Systems, Inc. (GA-ASI)), Kingfisher (BAE Systems), and Shadow and Pioneer (AAI) are to be flown within the year. The USN is implementing STANAG 4586 through the Raytheon Tactical Control Station (TCS) for the VTUAV RQ-8B Fire Scout” [Cummings, et al., 2006].

“STANAG 4586 is the only standard that exists to promote interoperability across a command and control network of unmanned aerial vehicles. Such standards are needed to truly ‘flatten’ the battlefield such that communications between allied forces occur without the significant uncertainty and technical difficulties that exist in joint operations today. The flexibility is lost when designing a system to a standard can be countered both with reduced costs and reduced degrees of freedom for uncertainty. This is particularly true when humans are in a supervisory control loop because introducing a standard clearly identifies boundaries. Moreover, introduction of interoperability standards aids in simplifying the design process, as well as the operation of these complex systems” [Cummings, et al., 2006].

“The optimum synergy among the various national UAVs deployed requires close coordination and the ability to quickly task available UAV assets, the ability to mutually control the air vehicles and their payloads, as well as rapid dissemination of the resultant information at different command echelons. This requires the employed UAV systems to be interoperable. In order to enable interoperability for UAV systems the implementation of standards for key system interfaces and functions is required. These standards are laid down in a number of existing or emerging NATO STANAGs and generally applied commercial standards documents” [Saiz & Lewandowski, 2008].

NATO has attempted to implement some commonality standards, reiterating the fact that commonality and interoperability between the United States and Allied countries must be a consideration when discussing UAS GCSs.

## **D. AREAS IMPACTED BY COMMONALITY AND INTEROPERABILITY**

The previous section explored some of the elements that affect the capability to achieve commonality and interoperability in UAS GCSs. This section examines the areas that are impacted if commonality and interoperability are achieved. These system areas cover a wide range of topics including: logistical elements, cost, and mission capability.

### ***1. Training***

There are several advantages from commonality that are applicable to training. Some advantages are consolidation of training courses and materials, increased reuse of training materials, and shorter retraining times that can focus on proficiency for assignments to common systems.

Consolidation of ground training courses and materials, as well as training material reuse, has been demonstrated by the F-35 JSF program. Lockheed Martin Corporation is building a training center at Eglin Air Force Base, FL, which will be used by all JSF pilots and maintainers. According to Peter Walker, project manager for Lockheed Martin simulations, training, and support, “Even though there are three variants of the aircraft and nine different countries involved with the F-35 Joint Strike Fighter program, 70 percent of the training is common” [Jean, July 2008].

Another example of flight and ground training courses and materials as well as training material reuse has been demonstrated by the JPATS. The JPATS is a set of primary flight training devices tailored in its design to replace the USAF T-37B and USN T-34C aircraft and their associated ground-based training systems. “JPATS consists of the T-6A Texan II air vehicles, simulators and associated ground-based training devices, a Training Integration Management System (TIMS), instructional courseware, and contractor logistics support. The Services will acquire common aircraft and the remaining components will be as common as possible” [Global Security, 1999].

The potential savings in training time and dollars from developing and fielding equipment with common attributes is well understood in the commercial world, especially where training costs are high, such as for airline flight crews [Held, Newsome,

and Lewis, 2008]. Southwest Airlines' decision to fly a fleet with a single airframe, the Boeing 737, simplifies the training of pilots, maintainers, and flight attendants [Treacy & Wiersema, 1994]. This training advantage is so important that the company will reject changes that reduce commonality. For example, "in more recent models of 737s, Boeing designed a 'glass cockpit' with computer screens replacing old fashioned analog dials. But in order to maintain interoperability, Southwest asked Boeing to program the new displays to look like the 'old steam gauge' dials and indicators that are so familiar to Southwest pilots" [Sheffi, 2005].

In 2003, the USAF deputy chief of staff for war-fighting integration prompted an NDIA study group to seek recommendations from major UAV platform manufacturers on how best to achieve a *plug-and-play* architecture that would allow multiple unmanned aircraft, sensors, mission control, and ground stations to work in a common network. The final report stated that, "Joint, interoperable UAV systems must become the norm for operational planning, training and exercises" [Erwin, 2003]. The group also wrote, "The Air Operations Center (AOC) is becoming inundated with a proliferation of 'tribal' stovepipes requiring 'tribal'-unique training, configuration-unique electronics and software, and an ever-increasing AOC bandwidth load and ground station logistics footprint" [NDIA, 2003].

The U.S. Army has started to implement within-service commonality for UAS ground stations, which has had a positive effect on operator training. The U.S. Army flies all of its unmanned aircraft with the One System Ground Control Station (OSGCS), a technology that can command different vehicles with a common data link. Being able to fly any of the unmanned aircraft systems using the same interface reduces the training time for operators, says Maj. Robert Kadavy, an action officer in the aviation directorate at U.S. Army MQ-1C Sky Warrior headquarters [Jean, December 2008].

Training cost savings achieved through commonality are well understood. The extent of these savings depends on the specifics of the program. The extent of commonality in the HMI systems will directly affect the cost savings for operator

training, while the extent of commonality in hardware systems will directly affect the savings for maintainer training.

## **2.     *Basing***

Commonality can improve basing within the DoD in several key areas. Basing focuses primarily on locations for operational and logistical placement of centers in support of land and amphibious or sea basing doctrines. From the operational standpoint, commonality would focus on centralized air vehicle control centers and geographically co-located launch and recovery sites. From the logistical standpoint, commonality would focus on locations of repair centers, storage facilities, and training centers [USMC Combat Development Command, 2009]. Even synergies of different systems with partial common elements or components can contribute to some type of beneficial basing results.

Commonality and basing can create several possible improvement areas. Commonality can affect basing by encouraging facilities consolidation, which can reduce the logistical footprints of an overall system by reducing geographical dispersion, consolidating facilities that support the fleet systems (e.g. repair centers, storage warehouses, and transportation shipping mechanisms). Consolidation of training facilities and use of similar equipment can also affect basing of common systems by enhancing and standardizing tactics, techniques, and procedures that can enhance the performance of the operator and reduce reaction or response times that can be significant to mission success. These can be easily controlled in a centralized location for training.

Centralized locations for intelligence gathering, analysis, filing, and distribution would be facilitated if UAS GCSs were common. Intelligence centers can encompass real-time intelligence gathering (networking), real-time data sharing between intelligence command posts, and provide expedited feedback of battle situational awareness to combat commanders.

Common GCSs, which are also interoperable, can reduce the numbers of launch and recovery sites and equipment, reducing required procurement and the LCC of various

UASs and their associated support equipment. This would create focal-point locations in operational theaters for maintenance, logistics, launch and recovery equipment, and common air vehicle control stations. However, security of the designated locations and facilities needs to be at such a level to prevent damage from enemy attacks. Successful enemy attacks on a common basing approach would be more detrimental to the U.S. forces than comparable attacks on distributed basing.

### ***3. Manpower Requirements***

Commonality influences manpower requirements through improvements in training, availability, flexibility, operator quality, capability, and productivity for military or contractor personnel required in performing operation and support field activities for UASs. Common UAS GCSs will require a reduced number of UAS training systems by enabling flexibility through a common architecture. A common architecture allows for a single UAS ground training system to be reconfigured for multiple UASs. A reduction in the number of UAS training systems will reduce manpower requirements for training. Commonality can also enable flexible interchange of personnel at different sea and shore UAS sites, which can reduce overall manpower requirements and increase efficiency through a common trained force servicing a number of UASs. Personnel working on the same systems ashore and at sea will enable, through common systems, a more flexible force.

“Manpower requirements provide the Navy a dynamic system for planning, programming, and budgeting total force manpower resources to support the operating forces and the shore establishment under peacetime and wartime conditions” [DoN, 1998]. Manpower requirements for UASs include: 1) program management, development, engineering and logistics, 2) contractor engineering, manufacturing, development, and support and, 3) military or contractor operation and support field activities.

Operational UAS GCS manpower requirements include vehicle and sensor operators, as well as any analytical support as required. AVO staffing will be dependent on the complexity of the UAS and the number of UASs to be operated. The most

complex UAS will need a highly trained operator with a formal flight-training program [Cummings, 2008]. Sensor operators will need a variety of training to operate the different sensor suites that include Electro-Optical/Infra-Red (EO/IR), radar, and Signal Intelligence Gathering (SIGINT). Analytical support for sensor and mission products will be provided by outside organizations.

#### **4. *Personnel Assignments***

Commonality influences personnel assignments through improvements in training, availability, flexibility, operator quality, capability, and productivity for military or contractor personnel required in performing operation and support field activities for UASs. Common UAS GCSs and training systems allow for a reduction in the number of billets required for operating and supporting operational and training systems. Operators trained in a common UAS will allow for the same operators to utilize the same equipment ashore and at sea, making personnel assignments more flexible and decreasing the need for specialized assignments. Common support realizes the same flexibility and efficiency as training and operations.

Personnel assignments for the USN are managed through the Navy Personnel Command (BUPERS). Management includes assigning Naval Enlisted Classification and Naval Officer Classification. Naval classifications “identify a skill, knowledge, aptitude, or qualification...enhancing efficient use of personnel in distribution and detailing” [Navy Personnel Command, 2004]. Training and classification supplements the total force manpower requirements, but are more specifically targeted to individuals and their skill sets.

As with operator manpower requirements, personnel assignments will include both operations and support functions. New designators should be implemented for the operations, but no new major designators need to be required for support functions. Cross service support training should be utilized along with new minor designators for support functions. Cross service training decreases the manpower and facilities requirements needed for training, which reduces cost.

## 5. *Reliability and Maintainability*

Reliability and maintainability (R&M) have well documented effects on operational availability and LCC as systems reach maturity. Maturity in the context of this discussion is the point where no more or very little improvement to R&M should be expected. As more operating hours are accumulated at a faster rate due to more total users and higher utilization of shared common GCSs, system maturity will be achieved sooner.

Reliability growth rates will be accelerated for common systems because there will be increased total numbers of systems fielded and utilization will be higher for shared common resources. The reliability growth is achieved through analysis and corrective action for high failure rate components within a system [Smith & Oren]. MIL-HDBK-189: *Reliability Growth Management* includes concepts and principles of reliability growth, advantages of managing reliability growth, and guidelines and procedures used to manage reliability growth. It allows the development of a plan that will aid in developing a final system that meets requirements and lowers the LCC of the fielded system [DoD, 1981].

There are some negative effects of commonality on the reliability of common systems. Although increased commonality will decrease the number of components that need to be developed, complexity may increase if the components need to be more flexible or offer additional capabilities [Held, et al., 2008]. Factors such as greater complexity from enhanced functionality may lead to increased failure rates and reduced reliability for the system.

Maintainability improvement is a reduction in the Mean Time to Repair (MTTR) and total Maintenance Man-Hours (MMH). MTTR and MMH can be reduced much faster for common systems because there will be larger total numbers of operators and more systems fielded in a shorter period of time. This reduction is mainly accomplished through maturing of maintenance procedures and tools through continuous analysis and correction of deficiencies documented by users and testers.

## 6. *Other Logistical Areas*

There are several logistics elements not previously mentioned that are affected by commonality. Facilities, technical data, support equipment, and supply support are some of the elements for which commonality will have the greatest impact.

One of the main affects of commonality on facilities other than common basing, which has been previously discussed, is the opportunity to utilize a common depot facility. Common depots will result in higher utilization of facilities, tooling, and manpower [Catington, Knudson, and Yodis, 2000]. As a result of the 1991 Base Realignment and Closure (BRAC), the U.S. Army and USAF were able to consolidate depot repairs for sensors, airborne avionics, electronic warfare equipment, and radios. This consolidation of depot repair for common systems resulted in an 83.7 percent reduction in depot repair cost for the affected work [Braman, 1997].

Commonality allows the use of common technical publications, including operator and maintenance manuals. Common maintenance manuals have advantages beyond just reduced total development cost. Technical manual updates of repurposed 737NG manuals for the P-8A, which happens periodically for every platform, will be shared with commercial common 737NG fleet operators [Figueras, 2007].

If common systems are designed with common interfaces, there is an opportunity to procure and use common support equipment. A decision was made by the USN to integrate a common cockpit into the MH-60S and MH-60R. The Navy estimates a cost avoidance of \$80 million on different support equipment and components [PMA-299, 2009].

A benefit of having common supply support or spare parts is that the total number of spares required to support the fleet can be reduced. If different operators of a common system agree to share a common pool of parts, the total number of spares required can be reduced significantly [Boeing Commercial Airplanes, 2009]. An example of benefits from this type of cooperative agreement has been proven beneficial in the global

commercial airline business with the rotatable pool of spare parts available to all customers that buy the service [Gill, 2003].

There are at least two disadvantages of having common spare parts. These disadvantages include finding major design defects that exist in the parts that may ground or significantly restrict an entire fleet, and obsolescence of common parts, which could create a shortage of parts within the supply chain. If one part is defective or becomes obsolete, it affects every system in the inventory that uses that part.

## **7. Cost**

When commonality is considered, the most frequently stated benefit is reduced cost. Costs associated with commonality not already discussed in other sections include Research and Development (R&D) cost, procurement cost, and inventory storage cost.

Although increased commonality will decrease the number of components that need to be developed, the development costs may increase if the component needs to be more flexible or offer additional capabilities [Held, et al., 2008]. An example of this is the Single Channel Ground and Airborne Radio System (SINCGARS) that was developed in the 1980s. Initially, the USAF and the U.S. Army were pursuing separate programs for an airborne radio, each with its own R&D costs. The initial cost was estimated to be \$13.7 million for the U.S. Army and \$32 million for the USAF. The cost of adding USAF requirements into the U.S. Army program was estimated to be \$16 to \$22 million, for an overall savings of \$10 to \$16 million arising from a reduction in the number of R&D efforts, despite a higher total overall R&D cost [GAO, 1985]. If a component can be common with one that is already available, development costs can be very low or even zero. The U.S. Marine Corps was able to use the U.S. Army's Shadow as "a '100 percent' solution" to their need for reconnaissance, surveillance, and target acquisition capabilities without any service-unique modifications [GAO, 2009]. The U.S. Marine Corps was able to avoid the \$180 million development cost and leveraged existing production facilities, which reduced program risk and cost significantly.

The relative magnitude of economies of scale and purchasing power compared with excess capability will determine the net impact of parts costs [Held, et al., 2008]. Common components offer a decrease in unit costs as a result of production economies of scale. For instance, procurement savings for the USN MH-60S and MH-60R common cockpit is expected to be \$105.8 million [PMA-299, 2009]. Greater commonality can also allow for greater purchasing power and increased competition among vendors for a common part as a result of the higher volume. However, costs do not necessarily decrease. Common components provide *excess functionality*. For instance, one transportation vehicle manufacturer decided that a common electric cable design for both low-end and high-end items was too costly to field on the low-end products [Nobelius & Sundgren, 2002]. An uncommon part was fielded, resulting in a nearly 50 percent reduction in parts costs.

Inventory holding cost is the cost of carrying one unit of inventory for a period of time. Holding cost is the sum of capital cost, handling cost, storage cost, obsolescence cost, and other costs such as theft and damage. The cost of storing and handling the inventory may be opportunity costs in that a reduction in costs would not be realized unless distribution facilities and personnel associated with handling were reduced. Use of common components among different systems with different life cycles may result in decreasing obsolescence costs. An increase in the number of common components is expected to decrease the number of units held in inventory. This change arises from increased risk pooling and reduced relative variability of demands. Net inventory cost, however, may either decrease or increase, depending on the unit price effect. Careful consideration of the relative magnitudes of these costs is important [Held, et al., 2008].

When determining whether to implement commonality, all of the elements must be considered. A business case analysis that considers all of the advantages and disadvantages of commonality is appropriate.

## **8. *Mission Capability***

Mission capabilities within multiple theaters of warfare can be improved and exploited by the use of common and interoperable systems in conjunction with common

tactics, techniques, procedures and equipment. If a common and interoperable GCS were developed, it must be able to support all missions that are currently being conducted in theater of operations and also support the future growth of mission capabilities. If the GCS did not support certain mission threads, stovepiped stations would be developed instead and would defeat the purpose of commonality. All mission scenarios and capabilities of UASs must be initially identified.

If a common GCS is to be developed to support all or most possible mission scenarios, a user-needs assessment must be conducted to rank the highest to lowest priorities of current and future mission threads and concepts. This will allow the systems engineer to concentrate on the must-haves of system functionality and deliver to the user what they need for mission success. If the systems engineering principles are not conducted properly when determining the key attributes and requirements of a common GCS, attempting to accomplish the multitude of required UAS missions and capabilities described earlier might not be achieved.

## IV. PROBLEM SCOPING

The research effort by the JUCCS team generated information spanning a wide breadth of material associated with the UAS community. Completing the efforts described in later sections of the paper required limiting the scope of the focus area to identify a subset of the problem space that could be addressed with limited time and resources of this project.

The first scoping effort limited the problem area to a subset of the *elements influencing commonality and interoperability* described in Chapter III.C. For each of the elements, the team chose a few particular aspects of UAS GCS commonality and interoperability based on an understanding of those areas, quality and quantity of available information, and the feedback received from stakeholders as to their interest areas. The list below summarizes the selections made by the team for further investigation with respect to elements affecting commonality, they aided the JUCCS team in production of the functional architecture described in latter sections of the paper:

- Airframe Size and Groupings - Limit scope to Groups 3 and above.
  - Mission and operational procedures for Group 3 and above UASs share much more in common than Groups 1 and 2 (small UASs). Eliminating the smaller systems allows a more in-depth concentration on larger UASs.
- Air Vehicle Control versus Mission Specific Payload - Explore commonality and interoperability for air vehicle control functions only.
  - Payloads for UASs are very specific to the mission of the aircraft. These missions may vary greatly depending on the nature of the need. Air vehicle command and control, however, shares many common functions regardless of the aircraft mission and payload. For this reason, the scope will be limited to air vehicle control functions to maximize the impact of the proposed architecture.
- Human-Machine Interface - Examine common HMI for air vehicle control functions only.
  - Commonality from a human machine interface standpoint will be limited to ensure adequate resources for a thorough study. The functional focus of the proposed architecture will be limited to air vehicle control, so the HMI considerations will also be limited as such.

- Hardware and Software - Hardware and software allocation is not required.
  - The study will limit scope to functional level. Since no physical allocations will be determined, differentiation between software and hardware functions is not required.
- Implementation through Retrofit or New Production - Consider implementing the proposed functional architecture on new production assets only, retrofit will not be explored.
  - Limiting scope to new production assets will allow greater strides to be taken in implementation of a common architecture. Requiring retrofit of existing systems would limit the capability to implement new common functions in the architecture due to current system limitations.
- Department of Defense Multiservice Cooperation - Concentrate on Department of Navy systems and requirements.
  - The first step in achieving commonality across the DoD is to ensure some commonality within the individual services. Since this objective is not currently attained within the Navy, this study will limit the focus to Department of Navy systems.
- United States and Allied Cooperation - Limit scope to U.S. only.
  - The first step in achieving commonality across allied forces is to ensure commonality within the U.S. DoD. Since this objective is not currently attained, this study will focus on U.S. systems only as a possible stepping stone for future allied commonality.

The second scoping effort limited the JUCCS benefit analysis to a subset of the *areas impacted by commonality and interoperability* described in Chapter III.D. The list below summarizes selections made by the JUCCS team for further investigation with respect to the areas impacted by commonality, they will aid the JUCCS team in production of the benefits analysis described in latter sections of the paper:

- Training – Training is the primary focus for the benefits of the proposed common architecture.
  - When investigating common HMI related to air vehicle control functions, there appears to be a potential for benefits from a training perspective. These potential benefits arise from the common human interface that may allow some consolidation of training assets. Due to this potential, training will be the focus for possible benefits of the common architecture.
- Basing - Potential benefits examined only when related to training as described in above section.

- Manpower Requirements - Potential benefits examined only when related to training as described in above section.
- Personnel Assignments - Potential benefits examined only when related to training as described in above section.
- Reliability and Maintainability (R&M) - Not examined further as part of this effort.
- Other Logistical Areas - Not examined further as part of this effort.
- Cost - Potential benefits examined only when related to training as described in above section.
- Mission Capability - Not examined further as part of this effort.

The scoping effort for JUCCS will allow creation of a common air vehicle control functional architecture for Group 3 and above UASs, which will facilitate some level of interoperability and commonality for the DoN operational community. Limiting the scope as described led to concentration on the current DoN UAS programs of BAMS, Fire Scout and STUAS. A benefits analysis performed by the JUCCS team shows that programs implementing the recommended solution will realize savings in the logistical area of training.

THIS PAGE INTENTIONALLY LEFT BLANK

## **V. TRAINING AS AN AREA OF INTEREST**

As previously discussed, there are current DoD programs that utilize common training concepts: the Joint Strike Fighter, the Army One System, and the Joint Primary Air Training System. A common schoolhouse is one of the benefits cited for these DoD programs that may be applicable to UASs. In order to achieve the common schoolhouse training benefit, a standardized training for AVOs would need to be established. United States Joint Forces Command (USJFCOM) recognized this and established a command for UASs. This command enacted policy identifying the required skill sets for an AVO. These skills sets would serve as the basis for the common training curriculum.

### **A. POTENTIAL BENEFITS FROM UAS AVO COMMON TRAINING**

As cited in the JSF example in Chapter III.D.1, their program is projected to experience 70 percent common training across the three variants. One of the methods that will enable common training is a common schoolhouse, which is being set up at Eglin Air Force Base. The DoN is exploring a common schoolhouse for UAS AVO training. A potential benefit from common UAS AVO training includes efficiencies gained in training overhead, such as configuration control and update of course curriculum. Common training also ensures standard UAS policies and procedures are taught. A common schoolhouse would provide a shore station opportunity and repository for fleet UAS training expertise [U.S. Fleet Forces Command (USFFC), 2009]. A study by NAVAIR Training Systems (PMA-205) that analyzed a common schoolhouse cited decreased manpower and facilities cost, but no quantifiable figures were provided [PMA-205, 2009].

The common training, especially if hosted at a common schoolhouse, would enable a reduced number of trainers (both simulators and Computer Based Training (CBT)), classrooms and personnel housing. This would result in a reduction in infrastructure. Another benefit of common training would be the reduced manpower required for support. The instructors, technicians and courseware managers would be co-located. This reduced infrastructure is due to training occurring at one site, vice

having training spread out at various locations. Finally, training assets would have a higher utilization rate and gain more efficient use of those assets. These benefits result in reduced infrastructure, reduced manpower, and higher asset utilization rate and would result in cost savings for the DoN. Estimated cost savings have yet to be determined.

## **B. OTHER GOVERNMENT EFFORTS TOWARD COMMON UAS TRAINING**

USJFCOM and the DoN are working towards establishing policy that addresses how UASs will be utilized in the future. In these policy documents, training has been addressed by identifying how the AVO will gain qualification. In addition to policy, the DoD has established a joint command that will facilitate acquisition of UASs.

### ***1. Joint Unmanned Aircraft Systems Center of Excellence***

The Joint Unmanned Aircraft Systems (JUAS) Center of Excellence (COE) is a government organization consisting of both military and government personnel that facilitates the development and integration of common UAS. Located at Creech Air Force Base, Nevada, the JUAS COE's mission statement is to:

Provide support to the Joint Operator and Services by facilitating the development and integration of common unmanned aircraft system operating standards, capabilities, concepts, technologies, doctrine, tactics, techniques, procedures and training. JUAS COE leverages existing COCOM and Service initiatives and activities to provide joint integrated solutions and improved interoperability. [Nellis Air Force Base, 2010]

On 1 November 2007, the JUAS COE was realigned under USJFCOM. Figure 18 depicts the different organizations responsible to the Commander USJFCOM. The JUAS COE organization structure has four primary divisions: Chief of Staff, Operations Division, Training Division, and Concepts Division, as shown in Figure 19. The Chief of Staff is administrative in nature. The Operations Division focuses on the training and tactics that are currently being employed in combat and in training areas throughout the world. They assess the capability gaps on current unmanned systems. They also coordinate with the Federal Aviation Administration (FAA) and foreign airspace centers and understand the flight regulations pertaining to UAS flight across the globe. The

Training Division focuses on the current and future methods of employment and standardization within the joint services and coalition forces. The Concepts Division concentrates on future capabilities and future threats to the unmanned systems. They attempt to project what type of unmanned systems will be employed in the distant future. They also attempt to roadmap what future capabilities will be required and the platforms associated with employing those capabilities.

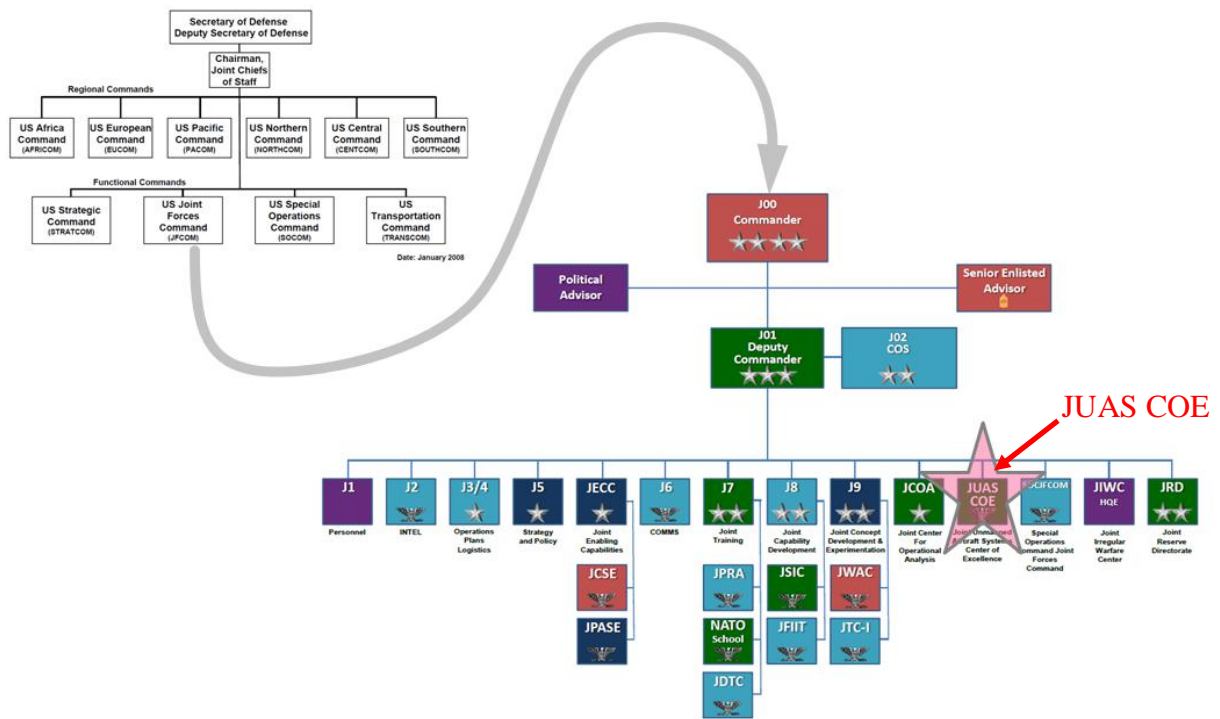

**Figure 18. JUAS COE Placement within the USJFCOM Organization Structure**

*While the commander of the JUAS COE is an O-6, the organization is placed on the same level as other organizations that have 1-star and 2-star commanding officers. Figure after [Colt, 2009].*

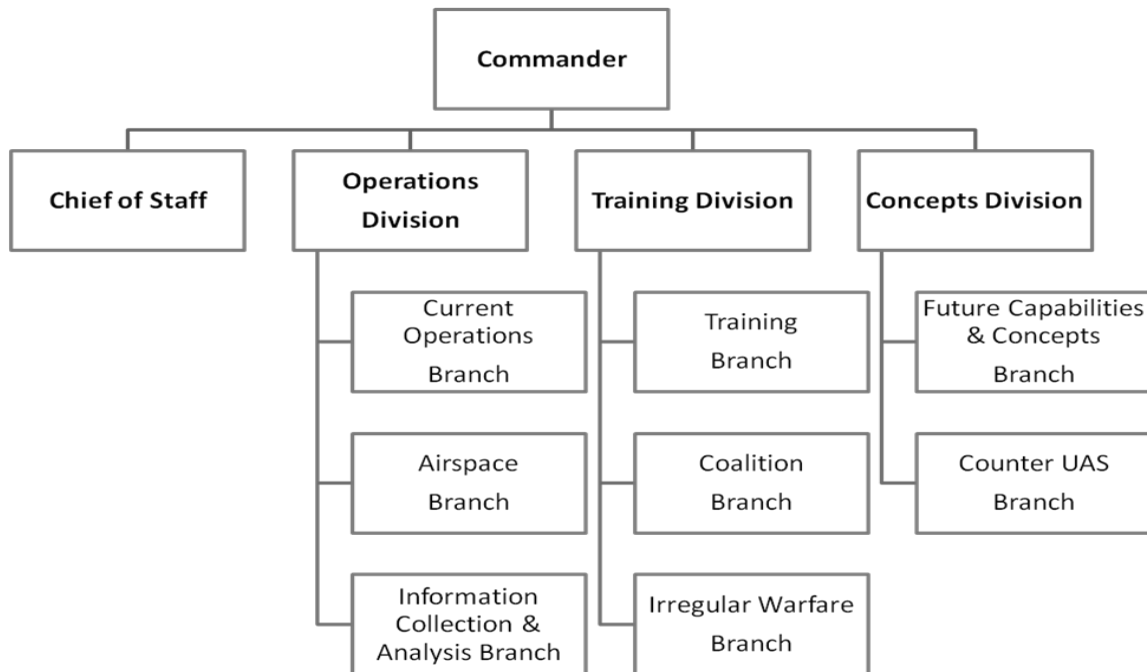

**Figure 19. JUAS COE Organization Structure**

*The JUAS COE Organization is comprised of four divisions consisting of Chief of Staff, Operations, Training, and Concepts. Figure from [Colt, 2009].*

## **2. Joint Unmanned Aircraft Systems Levels of Qualification**

The JUAS COE has identified five critical skill sets and Knowledge Skills and Abilities (KSAs) that are common throughout Joint UAS communities: UAS Flight Crew Skills (UASFCS), Joint Mission Qualification (JMQ), UAS Mission Crew Skills (UASMCS), Unique Service Skills, and Basic UAS Qualifications (BUQ) [Chairman of the Joint Chiefs of Staff (CJCS), 2009].

Knowledge, Skills, and Abilities (KSAs) are the attributes required to perform a job and are generally demonstrated through qualifying experience, education, or training. Knowledge is a body of information applied directly to the performance of a function. Skill is an observable competence to perform a learned psychomotor act. Ability is competence to perform an observable behavior or a behavior that results in an observable product. [U.S. Office of Personnel Management (OPM), 2010]

UASFCS identify practical skills to operate UASs with situational awareness and the ability to execute tasks during flight operations. The skills satisfy practical flight requirements for BUQ Levels I-IV [CJCS, 2009].

JMQ levels A to C provide general knowledge of the UAS mission and objective. This is critical to ensure the crews understand their role in accomplishing a larger military objective. It allows the operators the ability to coordinate and execute in joint operations. JMQ-A qualifications support unit-level Intelligence, Surveillance, and Reconnaissance (ISR) in support of the Joint Force Commanders (JFC). They also provide mission support with capabilities defined in the Joint Mission Task Lists (JMTL). JMQ-B qualifications support theater-level advanced ISR and Incident Awareness and Assessment (IAA) mission support with defined capabilities in the JMTL of the JFC [CJCS, 2009].

UASMCS are a group of skills required to ensure accomplishment of the assigned task. They are also mission skills to execute joint tactics, techniques, and procedures to meet UAS employment mission objectives. UASMCS satisfies practical mission requirements for JMQ Levels A-C [CJCS, 2009].

Unique Service Skills provide the UAS crewmember with the knowledge and understanding of service specific missions and associated requirements. Examples include maritime environment for naval UAS and pre-strike reconnaissance for air interdiction [CJCS, 2009].

BUQs have four levels associated with them consisting of BUQ-I through BUQ-IV. They focus on the general aviation knowledge for successful UAS employment and are the foundation for successful employment of UAS and subsequent qualifications. These qualification levels can be seen in Figure 20. Since these levels of qualification are necessary amongst different platforms of different services and missions, commonality among the various services can be reached. BUQs will be the primary focus of the JUCCS analysis.

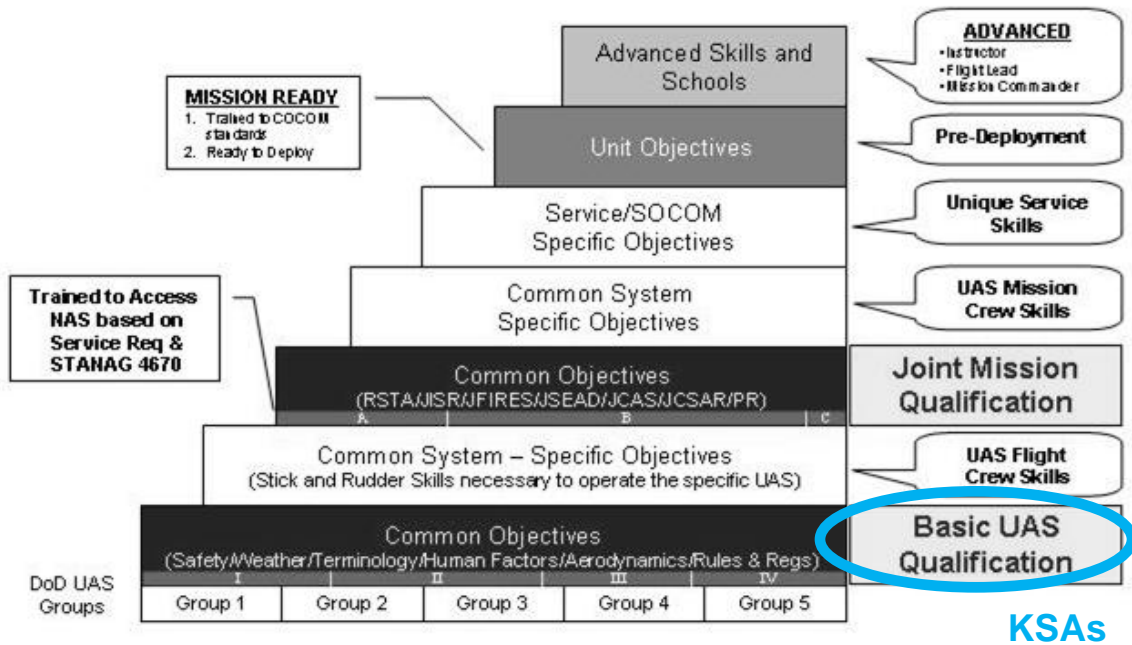

**Figure 20. UAS Qualification Hierarchy**

*There are multiple layers of skill sets that are essential to effectively operate a UAS. The lowest layer addresses the BUQs that are further discussed in this paper. Figure after [CJCS, 2009].*

UAS qualifications range from a minimum level of BUQ-I to a maximum level of BUQ-IV. A higher BUQ level requires that each subsequent level is mastered before the next higher level is attempted.

BUQ Level I is the minimum recommended training level for all UAS crewmembers. It possesses the required aviation knowledge and UAS skills to fly under Visual Flight Rules (VFR) in Class E, G, and restricted or combat airspace greater than 1200 feet Above Ground Level (AGL). Explanation of the different classes of airspace can be found in Appendix C. BUQ-I is the necessary training level for the small Group 1 UASs and some of the larger Group 2 UASs.

BUQ Level II possesses the required aviation knowledge and UAS skills to fly VFR in Class D, E, G, and restricted or combat airspace greater than 18,000 feet Mean Sea Level (MSL). Explanation of the different classes of airspace can be found in Appendix C. BUQ-II is the necessary training level for some of Groups 2 and 3 UASs.

BUQ Level III possesses the required aviation knowledge and UAS skills to fly VFR in all airspace greater than 18,000 feet MSL. BUQ-III is the necessary training level for some of Groups 3 and 4 UASs.

BUQ Level IV possesses the required aviation knowledge and UAS skills to fly in all weather conditions and classes of airspace up to 60,000 feet MSL. BUQ-IV is the necessary training level for some of Group 4 and all of Group 5 UASs. This indicates that larger, more complex UASs, such as BAMS, require the highest level of skills that have been categorized.

### **3. *Chairman of the Joint Chiefs of Staff Instruction 3255.01***

The purpose of the Chairman of the Joint Chiefs of Staff Instruction (CJCSI) 3255.01 titled *Joint Unmanned Aircraft System Minimum Training Standards (JUMTS)* is to identify the minimum knowledge required for a UAS crewmember to support JFC objectives. The instruction defines the grouping of various platforms (i.e. Groups 1-5) and the JUMTS skill sets (i.e. BUQ, UASFCS, JMQ, UASMCS, and Unique Service Skills).

CJCSI 3255.01 mandates that each group of UAS operators obtain a minimum level of BUQs. Minimum requirements for the BUQs are shown in Table 4. The DoD services will ensure that their UAS programs meet or exceed these minimums while fulfilling their responsibility of achieving the JUMTS skill set definitions. Waiver authority from not meeting the stated minimum requirements will be in accordance with DoD service directives. However, the waiver granting authority will be no lower than general or flag officer.

JUCCS will focus on UAS Groups 3-5 due to the complexity and amount of funding required to procure and sustain each platform, and train the required users. The JUCCS team will also focus on BUQs analysis since they are the foundation of all JUMTS and they allow for commonality within training joint operators.

**Table 4. Minimum BUQ requirements for Each UAS Group**

*This chart shows the comparison of UAS Group versus required BUQ levels. It shows that larger UASs require more BUQ qualifications. Figure after [CJCS, 2009].*

| UAS Group | BUQ I | BUQ II | BUQ III | BUQ IV |
|-----------|-------|--------|---------|--------|
| 1         | x     |        |         |        |
| 2         | x     | x      |         |        |
| 3         | x     | x      |         |        |
| 4         | x     | x      | x       |        |
| 5         | x     | x      | x       | x      |

**Focus Area (BAMS, Fire Scout, STUAS)**

**4. Fleet UAS Platform Wholeness Concept of Operations**

The *Fleet Unmanned Aircraft System (UAS) Platform Wholeness Concept of Operations (CONOPS)* was promulgated by the Commander, U.S. Fleet Forces Command. It delineates requirements and assigns responsibilities for all aspects of fleet UAS support to achieve *platform wholeness*. Platform wholeness covers the full range of organization, manpower, training (individual, team, and unit-level), logistics, maintenance, and shore support needed to establish BAMS, Fire Scout, and STUAS in the fleet.

The CONOPS is unclassified but for official use only. The intent is to present the reader with information needed to understand how the fleet will manage UAS within the Future Years Defense Program. This CONOPS summarizes the UAS Type Commander’s (TYCOM) intentions for UAS organizational structure, manpower, training, and maintenance.

The *Fleet Unmanned Aircraft System (UAS) Platform Wholeness Concept of Operations* is an important source of information for the JUCCS training analysis since it concentrates on the Group 3-5 UASs. It uses the *Joint Concept of Operations for Unmanned Aircraft Systems* [USJFCOM, 2008] and *Joint Unmanned Aircraft Systems Minimum Training Standards* [CJCS, 2009] as the primary references to training by

establishing a *modular training approach*. This approach utilizes several modules to form a course of instruction that has been found to accelerate the training, reduce costs, and provide greater efficiencies in the use of training resources.

In the near term, training of AVOs and MPOs will rely on legacy programs as the fleet develops the modular training approach. Modular training tailors a UAS training program to the specific requirements determined by UAS capabilities and mission requirements. The JUCCS team analyzed the different BUQ levels (I-IV) across multiple training regimes by comparing the number of KSAs that were learned in each schoolhouse.

### **C. NAVAIR AVIATION TRAINING SYSTEMS: ANALYSIS OF BASIC UAS QUALIFICATIONS**

On 15 October 2009, NAVAIR Training Systems (PMA-205) released a study titled *Naval Unmanned Aircraft Systems (UAS) Family of Systems (FoS) (Groups 1-5) Common/Core Training Requirements Study* [PMA-205, 2009]. PMA-205 analyzed the following existing training pipelines against Knowledge, Skills and Abilities (KSAs) for basic qualification requirements for UAS operators:

- Army Raven Mobile Training Team (MTT)
- Army Shadow training
- Army Hunter training
- Army Warrior training
- Air Force UAS Operator training

As a result, the spectrum of existing GCS architectures can be compared and analyzed for commonality traits with respect to training. This analysis can help determine whether the current training strategies already incorporate some commonality. A summary of the PMA-205 analysis has been broken down into qualification levels, and can be found in the charts on the following pages.

### 1. BUQ-I Analysis

BUQ Level I is the minimum recommended training level for all UAS crewmembers. The results of the analysis in Figure 21 show that the Army Hunter UAS trains to the most KSAs across all other the platforms and training pipelines. Since it meets the majority of the required KSAs, the Army Hunter UAS curriculum has the most potential to achieve a commonality requirement for a joint UAS training site for BUQ-I. The Army Raven MTT trains to the least of the KSAs when compared to other specific UAS platforms.

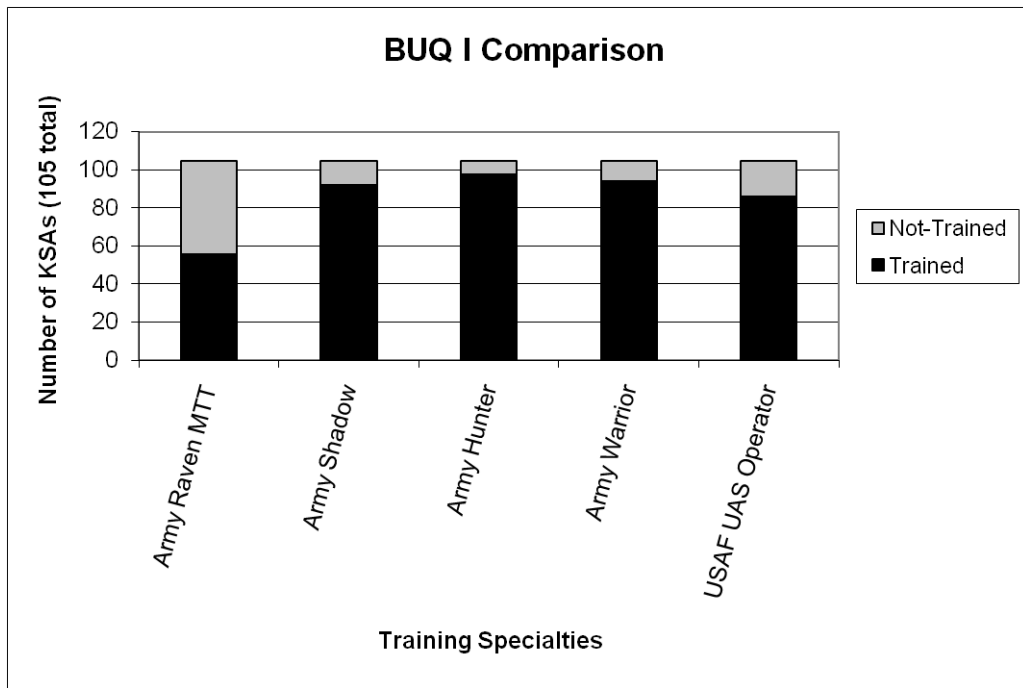

**Figure 21. BUQ-I KSA Analysis across Various UAS Training Pipelines**

*Not a single current training program examined provides all KSAs required for a Level I BUQ certification. Figure after [PMA-205, 2009].*

### 2. BUQ-II Analysis

The results of the analysis in Figure 22 show that the USAF UAS Operator pipeline trains to all of the KSAs analyzed. Since it meets all of the required KSAs, the USAF UAS Operator curriculum has the most potential to achieve a commonality

requirement for a joint UAS training curriculum for BUQ-II. The Army Raven MTT continues to train to the least of the KSAs when compared to other specific UAS platforms.

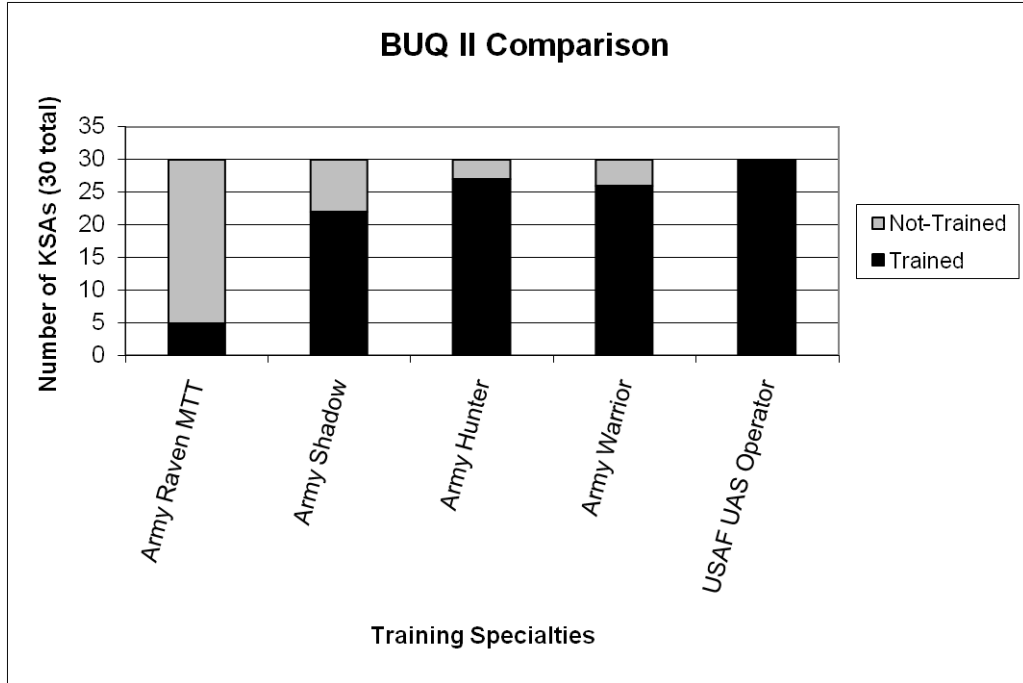
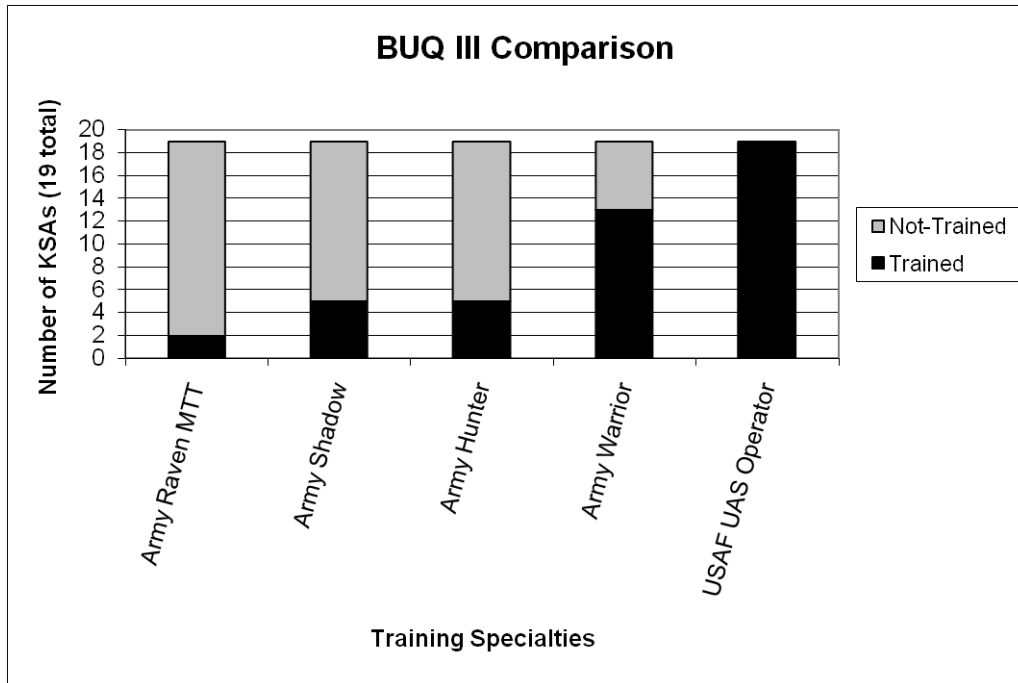

**Figure 22. BUQ-II KSA Analysis across Various UAS Training Pipelines**

*The USAF UAS Operator training provides all KSAs required for a Level II BUQ certification. Figure after [PMA-205, 2009].*

### 3. *BUQ-III Analysis*

BUQ Level III possesses the required aviation knowledge and UAS skills to fly VFR in all airspace greater than 18,000 feet MSL. The results of the analysis in Figure 23 show that the USAF UAS Operator pipeline trains to all of the KSAs analyzed. Since it meets all of the required KSAs, the USAF UAS Operator curriculum has the most potential to achieve a commonality requirement for a joint UAS training curriculum for BUQ-III. The Army Raven MTT trains to the least of the KSAs when compared to other specific UAS platforms.

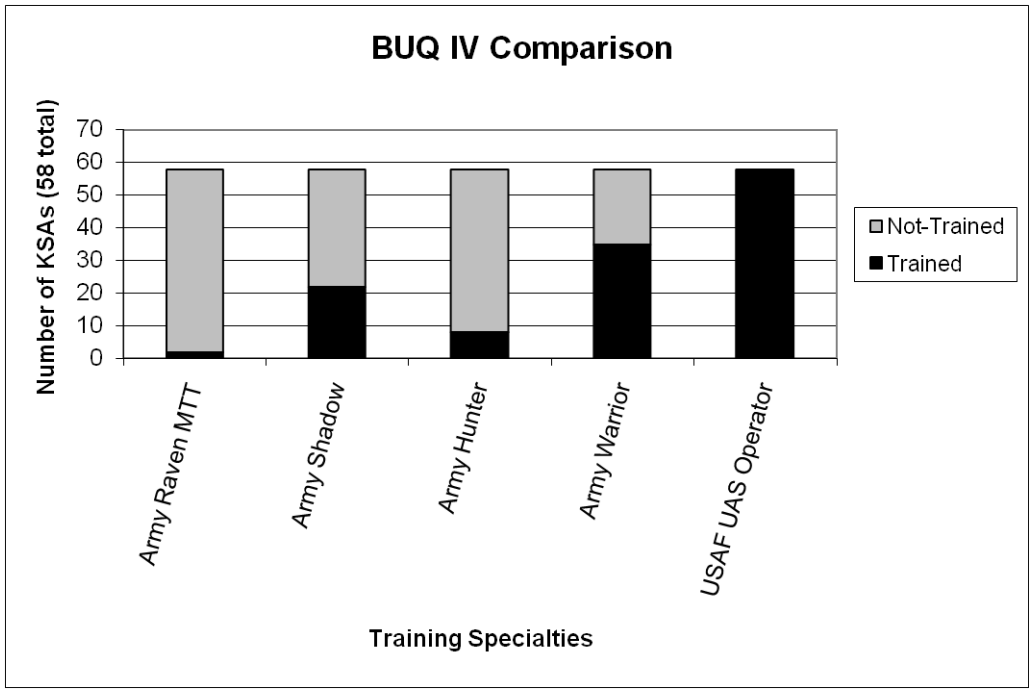

**Figure 23. BUQ-III KSA Analysis across Various UAS Training Pipelines**

*The USAF UAS Operator training provides all KSAs required for a Level III BUQ certification. Figure after [PMA-205, 2009].*

#### **4. BUQ-IV Analysis**

BUQ Level IV possesses the required aviation knowledge and UAS skills to fly in all weather conditions and classes of airspace up to 60,000 feet MSL. The results of the analysis in Figure 24 show that the USAF UAS Operator pipeline trains to all of the KSAs analyzed. Since it meets all of the required KSAs, the USAF UAS Operator curriculum has the most potential to achieve a commonality requirement for a joint UAS training curriculum for BUQ-IV. The Army Raven MTT continues to train to the least KSAs when compared to other specific UAS platforms.

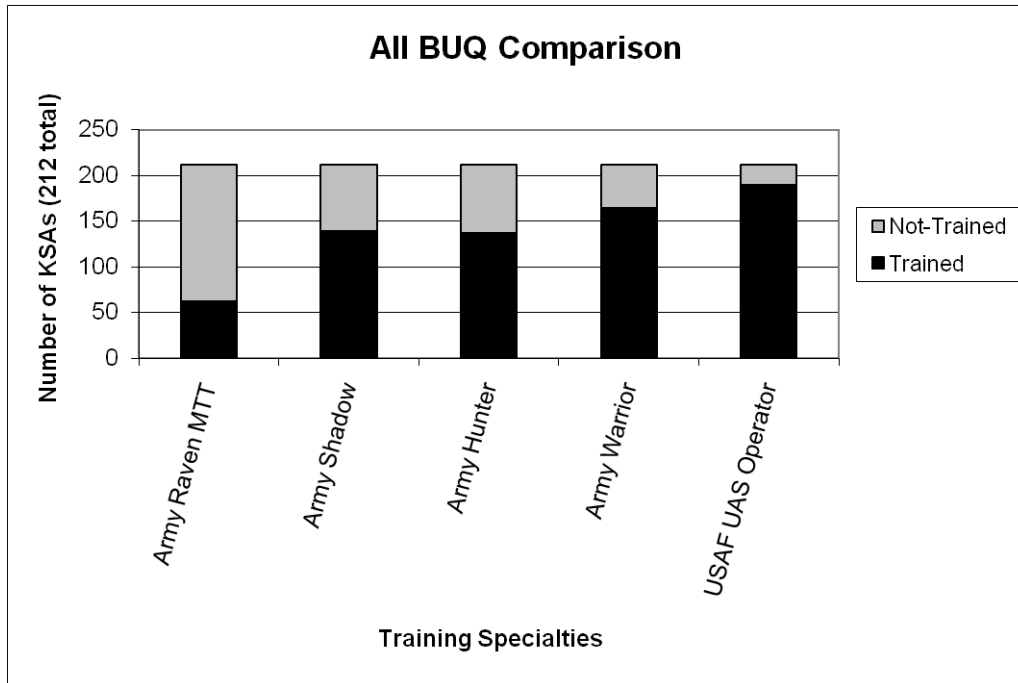

**Figure 24. BUQ-IV KSA Analysis across Various UAS Training Pipelines**

*The USAF UAS Operator training provides all KSAs required for a Level IV BUQ certification. Figure after [PMA-205, 2009].*

**5. BUQ-I through IV Combined Analysis**

The results of the analysis in Figure 25 show that the USAF UAS Operator pipeline trains to the most KSAs across all other platforms and training pipelines when BUQ Levels I-IV are combined. Since it meets the majority of the required KSAs, the USAF UAS Operator curriculum has the most potential to achieve a commonality requirement for a common joint UAS training site that trains to all BUQ KSAs. The Army Raven MTT trains to the least KSAs when compared to other specific UAS platforms.



**Figure 25. BUQ-I through IV Combined KSA Analysis across Various UAS Training Pipelines**

*The USAF UAS Operator training comes closest to meeting all required KSAs for gaining BUQ Levels I-IV certification. Figure after [PMA-205, 2009].*

The intent of reviewing the PMA-205 analysis is to determine whether or not current UAS training systems actually teach all of the UAS training requirements. A look at these various programs shows that none of them train to all of the KSAs required for BUQ Levels I-IV. Additionally, the study reveals that the training strategies do not share common goals, since they all teach to different numbers of KSAs for each BUQ level. This implies that there is little commonality between the current training systems.

These revelations lead to the following questions:

- If a common GCS architecture were created, would it allow greater efficiencies across the UAS training pipelines?
- What requirements are necessary for this type of common GCS?
- To meet these requirements, what architectural characteristics need to be developed?

The first step in answering these questions is to derive some requirements for a common GCS that relate back to the KSAs for the BUQ levels described above.

## **VI. REQUIREMENTS ANALYSIS FOR A COMMON GCS**

Limiting the scope of the project led to concentration on the current DoN UAS programs of BAMS, Fire Scout and STUAS. A requirements analysis of these UAS programs was conducted as part of the systems engineering process to understand the requirements of UASs and to establish a foundation from which to proceed. This analysis included programs of record which were in some stage of acquisition by the DoN as of fiscal year 2010. Additionally, further review of the source documentation led to the development of a set of requirements which were used for the basis of the proposed common GCS architecture discussed in Chapter VII.

### **A. OVERVIEW OF CURRENT NAVY UAS REQUIREMENTS**

A requirements analysis of the three UAS programs of interest began with an evaluation of their approved Capability Development Document (CDD) or Capability Production Document (CPD) and system specification. Exploration of each document revealed similarities and differences in the areas of primary interest to the JUCCS team: training, interoperability, and requirements explicitly detailing commonality. Also examined from each program's requirements documentation were the Key Performance Parameters (KPPs) and Key System Attributes. The following sections provide these analyses.

#### ***1. Key Performance Parameters***

KPPs are those system attributes that are considered essential for successful mission accomplishment. Each acquisition program generally contains a limited number of KPPs (usually eight or fewer) that capture those parameters needed to reach the overall desired capabilities for the system. Failure to meet a KPP threshold can be cause for the system selection to be reevaluated, the program to be reassessed or terminated, or the content of production increments modified [USD(AT&L), 2008].

Table 5 displays the KPPs for BAMS, Fire Scout, and STUAS.

**Table 5. Comparison of DoN UAS Key Performance Parameters**

*This list shows those requirements considered most important to determine the success of each program. None of these requirements is levied on the GCS, nor is there any application of a requirement across all three programs with the exception of the Net Ready KPP.*

| PARAMETER  | BAMS  |   | Fire Scout   |  | STUAS  |  |
|--|---|---|--|--|--|--|
|  | Threshold   | Objective   | Threshold  | Objective  | Threshold  | Objective  |
| Effective Time on Station                                      | On station 24/7 (ETOS 80%)  | On station 24/7 for 30 consecutive days (ETOS 95%)          |  |  |  |  |
| Mission Radius   | ≥ 2,000 nm  | ≥ 3,000 nm  |  |  |  |  |
| Net Ready-KPP  | COMMON  | COMMON  | COMMON   | COMMON   | COMMON   | COMMON   |
| Level of Interoperability 2 LOS Capability                     | LOS ISR Payload sensor data reception to Maritime Forces afloat (CVN, LHA, LHD) | LOS/BLOS multi-ISR payload reception to Maritime Forces     |  |  |  |  |
| Level of Interoperability 1-5                                  | MOB MCS shall be capable of LOS/BLOS LOI 1-5 of the UA                          | MOB/FOB MCS shall be capable of LOS/BLOS LOI 1-5 of the UAS |  |  |  |  |
| Ao   | ≥ 0.7 at IOT&E<br>≥ 0.8 at IOC + 2 years  | ≥ 0.9   | ≥ 0.85   | ≥ 0.95   |  |  |
| Material Availability  |   |   |  |  | 80% IOC<br>85% FOC   | 90% IOC<br>95% FOC   |
| Day Sensor Resolution from 3,000 ft altitude                   |   |   |  |  | EO sensor shall support classification of 1m size object       | EO sensor shall support classification of 0.5m size object     |
| Night Sensor Resolution from 3,000 ft altitude                 |   |   |  |  | IR sensor shall support classification of 3m size object       | IR sensor shall support classification of 1.5m size object     |
| Launch and Recovery from Air Capable L-Class Ships             |   |   |  |  | Combined max ship motion no less than ± 3° pitch and ± 5° roll | Combined max ship motion no less than ± 5° pitch and ± 8° roll |
| Module/Interchangeable Payload                                 |   |   |  |  | Change payloads in < 60 min                                    | Change payloads in ≤ 30 min                                    |
| AV Endurance with mission payload                              |   |   |  |  | 10 hrs   | 24 hrs   |
| Automatic launch and recovery of AV with max. displacement of: |   |   | ± 3° pitch and<br>± 5° roll host platform<br>deck displacement<br>from 0° centerline | ± 5° pitch and<br>± 8° roll host platform<br>deck displacement<br>from 0° centerline |  |  |
| Target Identification  |   |   | 6 km   | 16 km  |  |  |

It should be noted that the only KPP shared between all three programs is the Net Ready KPP mandated for all acquisition programs. Aside from this requirement the three programs have established their own unique criteria for essential system capabilities.

With the majority of KPPs involving the air vehicle, it is apparent that the GCS is not the focus of key requirements for existing programs. Training is not shown as a KPP in any of these programs. Commonality is also not a focus of required capabilities for any of these systems.

## **2. *Key System Attributes***

Key System Attributes are those system attributes considered most critical or essential for an effective military capability but not selected as KPPs. Key System Attributes provide decision makers with an additional level of capability prioritization below the KPP but with senior sponsor leadership control. Key System Attributes and other performance attributes will be based on analysis of the required capability [USD(AT&L), 2008].

BAMS has Key System Attributes that address the deployability of the air vehicle, mission planning, flight, on station capabilities, and sensor capabilities. None of the Key System Attributes focus on the GCS capabilities. Other requirements are levied on the GCS that include the ability to control multiple air vehicles (three as a threshold and twelve as an objective). The GCS is required to be capable of transferring control of an air vehicle from one BAMS GCS to another BAMS GCS [PMA-263, 2007]. There are no requirements to be interoperable or common with other platform GCSs.

Similarly, the Key System Attributes for the Fire Scout program do not focus on the GCS or on training. The Fire Scout program does require that the GCS be capable of mission planning, air vehicle control, receipt of data and dissemination of data [PMA-263, 2008]. The GCS shall be able to control two Fire Scout aircraft simultaneously and transfer control of an aircraft from one GCS to another [Northrop Grumman Systems Corporation, 2007]. Again, this transfer is only required between Fire Scout GCSs.

The STUAS Performance Based Specification (PBS) contains three pages of Key System Attributes. System reliability, sensor performance and affordability are the subjects of Key System Attributes [PMA-263, 2009]. Once again, training and commonality are not listed in any of the Key System Attributes.

### **3. *CDD, CPD and System Specification Comparison***

For each of the programs examined, the CDD, CPD and system specification was found and then compared and contrasted with one another. Some surprising commonality in requirements language was discovered and can be seen in Table 6. The extent of the similarity suggested that each program copied wording from the previous program. Yet, interestingly, there was no requirement for each individual program to specifically leverage off the other system's development or to gain in any way from previous development. Each training system separately developed its own training support system.

**Table 6. CDD and CPD Wording Related to Training for DoN UASs**

*This table compares some of the similar requirements from BAMS, Fire Scout and STUAS with respect to training. Note the similarities in wording across the various systems.*

| <b>BAMS</b>   | <b>Fire Scout (VTUAV)</b>   | <b>STUAS</b>  |
|---|---|---|
| Training shall be available at any operating location and will be sustainable over the life of the system.  | Training will be available at any operating location, through the use of training devices and a distributed learning system, and will be sustainable over the life of the system.                     | Training will be available at any operating location, through the use of training devices and a distributed learning system, and will be sustainable over the life of the system.                   |
| Appropriate human performance metrics, methodologies and verification procedures will be part of the BAMS UAS training system.  | Appropriate human performance metrics, methodologies and verification procedures will be part of the VTUAV System training system.  | Human performance requirements will be considered in the design of the Tier II/STUAS from the earliest stages of acquisition and throughout the life cycle engineering activities.                  |
| The BAMS UAS training system should be supportable by the Navy personnel distribution system and will ensure qualified personnel report to assume assigned duties within a minimal turnover period. | The VTUAV System training system will be supportable by the Navy personnel distribution system and will ensure qualified personnel report to assume assigned duties within a minimal turnover period. | The Navy’s STUAS training system will be supportable by the Navy personnel distribution system and will ensure qualified personnel report to assume assigned duties with a minimal turnover period. |

In Table 7, it is apparent that each program looked to have embedded training capability so that training could leverage off the operational system. Although this may help a specific program’s ability to reduce its own training related expenses, it does nothing to assist the other program’s efforts. Likewise, there appears to be foresight in the need to leverage off the operational system software development, however nothing is captured in the requirements to leverage off software development completed by other programs. Each program is on their own in developing separate hardware and software solutions, even though they strive for similar goals.

**Table 7. System Specification Wording Related to Training for DoN UASs**

*This table shows some of the system specification wording across the various programs. Note that the programs are all discussing embedded capabilities for usage in training, but none are requiring commonality between the other platforms.*

| <b>BAMS</b>   | <b>Fire Scout (VTUAV)</b>   | <b>STUAS</b>  |
|---|---|---|
| <p>The UAS Training System (TS) will be an integrated system which will use the baseline developed Top Level Operator Mission Task Analysis and the Contractor and Government performed Instructional Systems Development (ISD) Front End Analysis (FEA) processes to determine specific training requirements.</p> | <p>The VTUAV CS shall be compatible with embedded and add-on interactive training.</p>  | <p>As an integral portion of the GS, the MTD provides the ability to execute training through a safe, interlocked interface which physically isolates a GS workstation from communicating with any AV, while still using the GCS operational software to provide proficiency, emergency procedure and mission rehearsal training to the crew.</p> |
| <p>The MOB MCS shall include an integrated, full-mission training capability.</p>   | <p>The VTUAV system shall provide for training of organizational level operator and maintenance personnel.</p>  | <p>The integrated GCS and UAS MTD assembly shall provide the sufficient and necessary capabilities to complete emergency procedures training, proficiency training, and mission rehearsal for all users.</p>  |
| <p>The MOB MCS shall include an integrated, full-mission training capability.</p>   | <p>All electronic media training materials shall function stand-alone via CD ROM, over the web, via Navy E-Learning/Navy Knowledge On-Line, and from Navy-Marine Corps Internet (NMCI) computers.</p> | <p>The software in GCS used during flight operations shall be the same software when interfacing with the MTD.</p>  |



- The Ground Control Station (GCS) shall enable Air Vehicle Operator (AVO) training commonality across multiple Unmanned Aircraft System (UAS) platforms.

For AVO training commonality, programs are directed to ensure compliance with the BUQs defined in *CJCSI 3255.01 Joint Unmanned Aircraft Systems Minimum Training Standards* [CJCS, 2009]. As identified by the expanded JUCCS analysis, all but seven of these BUQs can be accommodated through implementation of a common GCS. By requiring GCS commonality, common AVO training can be achieved. Therefore, the following specific characteristics have been extracted for the GCS in order to facilitate the common AVO training concept:

- The Ground Control Station (GCS) shall have a common Human-Machine Interface (HMI) for Air Vehicle Operator (AVO) functions.

In order to achieve a common GCS and common AVO training, a common HMI is necessary for AVO functions.

- The Ground Control Station (GCS) shall allow for directed vice controlled air vehicle operation.

Fire Scout has set requirements for a point-and-click route planning to include terrain avoidance warning, fuel calculations, and radar terrain masking. The necessity for a point-and-click route is considered to be the *directed* as opposed to the *controlled* UAS philosophy.

- The Ground Control Station (GCS) shall allow for separate Human-Machine Interfaces (HMI) for payload and air vehicle control.

Fire Scout has called for a GCS “consisting of an AVO and an MPO work station.” It goes on to state that “crews will consist of an AVO and an MPO” [PMA-205, 2008]. The separation of these functions requires separation of the HMI enabling performance of the functions.

- The Ground Control Station (GCS) shall have a common mission planning system.

Fire Scout requires that the GCS will be used to plan and monitor flights for performance of assigned missions [PMA-205, 2008]. A common mission planning system is necessary to enable a common GCS with common AVO training functions.

## **2. *Additional Requirements for a Common GCS***

Up to this point, evaluation of UAS GCSs has focused on AVO training. A common GCS would need requirements beyond the AVO training. To achieve greater potential benefits and to enable a common GCS, the following requirements are proposed by the JUCCS team in addition to aforementioned common AVO training:

- The Ground Control Station (GCS) shall enable interoperability between multiple Unmanned Aircraft Systems (UASs).

STANAG 4586, as discussed previously, details interoperability standard for UASs and GCSs. All three programs evaluated in this report require compliance with STANAG 4586. It is therefore reasonable to expect all future UAS programs to require interoperability.

- The Ground Control Station (GCS) shall enable common communications and data link management between multiple Unmanned Aircraft Systems (UASs).

The OSD Roadmap indicates that “all UAS systems will have the ability to communicate and can therefore act as relay nodes for C2 communications” [OSD, 2007]. In order to achieve this, it is essential for common communications and data link management.

- The Ground Control Station (GCS) shall utilize a common data format to enable communication between multiple manned and unmanned systems.

USD(AT&L) calls for accelerating the fielding of CDL compliant communications systems. The OSD Roadmap recommends “greater interoperability among system controls, communications, data products, data links, and payloads/mission equipment packages on unmanned systems” [OSD, 2007]. A common data format will enable increased interoperability and sharing of data collected by the air vehicle.

- The Ground Control Station (GCS) systems software and architecture shall be modular and scalable.

USD(AT&L) has directed the services “to develop and demonstrate a common, open, and scalable UAS architecture supporting Groups 2-5” [USD(AT&L), 2009]. The use of modular and scalable systems software and architecture will facilitate interoperability. It will also enable the incorporation of future technologies.

- The Ground Control Station (GCS) shall enable a common approach to simplify support and maintenance across multiple Unmanned Aircraft System (UAS) platforms.

The UAS Wholeness CONOPS requires that UASs shall use common approaches to simplify UAS support and maintenance.

- The Ground Control Station (GCS) shall enable a common approach to reduce the manpower requirements across multiple Unmanned Aircraft System (UAS) platforms.

The UAS Wholeness CONOPS requires that UASs shall use common approaches to UAS manpower support.

- The Ground Control Station (GCS) shall enable a common approach to minimize Unmanned Aircraft System (UAS) basing.

The UAS Wholeness CONOPS requires that UASs shall use common approaches to UAS manpower basing.

These requirements are those considered vital to a proposed common GCS. The first set of requirements will facilitate the common training while the others are a mixture of miscellaneous requirements that aid in the successful creation of a common GCS. The needs discussed above have been compiled into a comprehensive list in Table 8.

**Table 8. Necessary Requirements for a Common GCS**

*This table summarizes the requirements necessary for a common GCS. The table includes specific wording for the requirements along with the source of the requirement derivation.*

| <b>JUCCS Proposed Common Architecture Requirement</b>  | <b>Derived from</b>   |   |
|--|---|---|
|  | <b>Document(s)</b>  | <b>CONOP/Requirement</b>  |
| 1. The Ground Control Station (GCS) shall enable Air Vehicle Operator (AVO) training commonality across multiple Unmanned Aircraft System (UAS) platforms. | <ul style="list-style-type: none"> <li>• UAS Platform Wholeness CONOPS</li> <li>• CJCSI 3255.01</li> <li>• USD(AT&amp;L) ADM</li> </ul> | <ul style="list-style-type: none"> <li>• Field UASs with common AVO training standards.</li> <li>• Increase training efficiencies and decrease training time.</li> <li>• Reduce training requirements.</li> </ul> |
| 2. The Ground Control Station (GCS) shall have a common Human-Machine Interface (HMI) for Air Vehicle Operator (AVO) functions.                            | <ul style="list-style-type: none"> <li>• Fire Scout System Specification</li> <li>• STUAS CDD and PBS</li> <li>• BAMS PBS</li> </ul>    | <ul style="list-style-type: none"> <li>• UAS shall use a STANAG 4586 compliant GCS.</li> <li>• Human machine interfaces shall comply with MIL-STD-1472.</li> </ul>  |
| 3. The Ground Control Station (GCS) shall allow for directed vice controlled air vehicle operation.  | <ul style="list-style-type: none"> <li>• Fire Scout System Specification</li> <li>• STUAS PBS</li> </ul>                                | <ul style="list-style-type: none"> <li>• The GCS HMI shall be a directed type interface.</li> </ul>   |
| 4. The Ground Control Station (GCS) shall allow for separate Human-Machine Interfaces (HMI) for payload and air vehicle control.                           | <ul style="list-style-type: none"> <li>• Fire Scout NTSP</li> <li>• UAS Platform Wholeness CONOPS</li> </ul>                            | <ul style="list-style-type: none"> <li>• Operators shall operate a single GCS consisting of an AVO and an MPO work station.</li> <li>• Crews will consist of an AVO and an MPO.</li> </ul>                        |

**Table 8. Necessary Requirements for a Common GCS (continued)**

| <b>JUCCS Proposed Common Architecture Requirement</b>  | <b>Derived from</b>   |   |
|--|---|---|
|  | <b>Document(s)</b>  | <b>CONOP/Requirement</b>  |
| 5. The Ground Control Station (GCS) shall have a common mission planning system.   | <ul style="list-style-type: none"> <li>• Fire Scout NTSP</li> <li>• JUAS CONOPS</li> </ul>  | <ul style="list-style-type: none"> <li>• GCS will be used to plan and monitor flights for performance of assigned missions</li> <li>• Current doctrine provides for parallel planning processes for ISR/RSTA and Joint Fires.</li> <li>• UAS planning and employment considerations will be examined</li> </ul>   |
| 6. The Ground Control Station (GCS) shall enable interoperability between multiple Unmanned Aircraft Systems (UASs).                               | <ul style="list-style-type: none"> <li>• STUAS CDD</li> <li>• UAS Platform Wholeness CONOPS</li> <li>• Fire Scout System Specification</li> <li>• STUAS PBS</li> <li>• USD(AT&amp;L) ADM</li> </ul> | <ul style="list-style-type: none"> <li>• GCS shall be compliant with STANAG 4586 for system interoperability.</li> <li>• GCS shall be interoperable with other UAS operating and control systems.</li> <li>• GCS shall use a standardized user interface across all configurations.</li> <li>• Improve interoperability.</li> </ul>   |
| 7. The Ground Control Station (GCS) shall enable common communications and data link management between multiple Unmanned Aircraft Systems (UASs). | <ul style="list-style-type: none"> <li>• Fire Scout System Specification</li> <li>• Fire Scout NTSP</li> <li>• JUAS CONOPS</li> <li>• USD(AT&amp;L) ADM</li> <li>• OSD Roadmap</li> </ul>           | <ul style="list-style-type: none"> <li>• GCS shall be capable of interfacing with other fielded UASs via common C4I systems.</li> <li>• GCS shall have the capability for external and internal voice communications with other manned and unmanned systems.</li> <li>• A suite of communications systems shall include the common data link to provide continuous contact between system operators and the UAV</li> <li>• Field common data link compliant communications system leveraging to the greatest extent possible current and future interoperability profiles.</li> </ul> |

**Table 8. Necessary Requirements for a Common GCS (continued)**

| <b>JUCCS Proposed Common Architecture Requirement</b>   | <b>Derived from</b>  |  |
|---|--|--|
|   | <b>Document(s)</b>   | <b>CONOP/Requirement</b>   |
| 8. The Ground Control Station (GCS) shall utilize a common data format to enable communication between multiple manned and unmanned systems.                      | <ul style="list-style-type: none"> <li>• STUAS CDD</li> <li>• Fire Scout System Specification</li> </ul>   | <ul style="list-style-type: none"> <li>• GCS shall use standardized data and controls.</li> <li>• All communications systems shall meet DoD, U.S. and International frequency spectrum management policies and regulations.</li> <li>• Improve data access.</li> </ul>   |
| 9. The Ground Control Station (GCS) systems software and architecture shall be modular and scalable.  | <ul style="list-style-type: none"> <li>• STUAS CDD</li> <li>• Fire Scout NTSP</li> <li>• UAS Platform Wholeness CONOPS</li> <li>• USD(AT&amp;L) ADM</li> </ul> | <ul style="list-style-type: none"> <li>• UAS shall implement a modular open systems architecture.</li> <li>• AV and GCS software shall be modular and scalable.</li> <li>• System shall support existing Navy system external interfaces and implement an open systems architecture standard.</li> <li>• Adopt a common GCS architecture that is open and allows for modular functionality.</li> <li>• Develop and demonstrate a common, open, and scalable UAS architecture supporting Groups 2-5.</li> </ul> |
| 10. The Ground Control Station (GCS) shall enable a common approach to simplify support and maintenance across multiple Unmanned Aircraft System (UAS) platforms. | <ul style="list-style-type: none"> <li>• UAS Platform Wholeness CONOPS</li> </ul>  | <ul style="list-style-type: none"> <li>• UASs shall use common approaches to simplify UAS support and maintenance.</li> </ul>  |

**Table 8. Necessary Requirements for a Common GCS (continued)**

| <b>JUCCS Proposed Common Architecture Requirement</b>   | <b>Derived from</b>  |  |
|---|--|--|
|   | <b>Document(s)</b>   | <b>CONOP/Requirement</b>   |
| 11. The Ground Control Station (GCS) shall enable a common approach to reduce the manpower requirements across multiple Unmanned Aircraft System (UAS) platforms. | <ul style="list-style-type: none"> <li>• UAS Platform Wholeness CONOPS</li> <li>• BAMS CDD</li> <li>• Fire Scout CPD</li> <li>• USD(AT&amp;L) ADM</li> </ul> | <ul style="list-style-type: none"> <li>• UAS shall use common approaches to UAS manpower support.</li> <li>• The workload associated with training must be analyzed and accounted for in the manpower requirements.</li> <li>• Increase pool of UAS pilots/operators.</li> </ul> |
| 12. The Ground Control Station (GCS) shall enable a common approach to minimize Unmanned Aircraft System (UAS) basing.  | <ul style="list-style-type: none"> <li>• UAS Platform Wholeness CONOPS</li> </ul>  | <ul style="list-style-type: none"> <li>• UAS shall use common approaches to UAS manpower basing.</li> </ul>  |

## VII. JUCCS PROPOSED COMMON GCS ARCHITECTURE

The common architecture proposed by the JUCCS team was developed using the requirements derived from the analysis in the previous section. The architecture development focused on the air vehicle control functions with a modular, scalable construct that would enable a common GCS across multiple platforms. This approach was influenced by the requirements for commonality as directed in the ADM. The architecture development approach included research and analysis of current relevant architectures and architecture development strategies, development of an external systems diagram, and development of a functional architecture [Dam, 2006]. The architecture focused on the human-machine interface of the air vehicle control functions.

### A. JUCCS ARCHITECTURAL ELEMENTS

#### 1. *Inspiration for the Architectural Structure*

The JUCCS architecture is based on the ability to be both modular and scalable in accordance with the requirements derived in Chapter VI.B. The concept will be limited to a functional allocation to allow for a variety of physical architectures. This allows different number of crew positions based on mission requirements and GCS operating locations. A two person crew might be needed for a smaller UAS while an eight person crew layout might be needed for a larger UAS.

Limiting the architecture to a functional level enables the hardware to be customized based on the operating environment as long as it maintains the same functional elements. As an example, a mouse is a 2-D input device that can be used well in shore based GCS applications while for a ship or airborne control station it might not be as effective since it can move with the motion of the vehicle. This condition may lead to the use of a trackball instead. The functional architecture will not limit this type of hardware change.

Since the equipment may be mounted in different operating environments, it may become necessary to use hardware that is more robust based on its intended operational

environment. A shipboard GCS might need humidity and salt resistant computer hardware and antennae, while a land based GCS would have less stringent environmental requirements. This architecture will be able to support different physical allocations while ensuring a functional allocation that is common. Therefore, the system will be modular and scalable per Requirement 9 found in Table 8.

## **2. *Enabling Common AVO Training***

Through the requirements analysis and the list of requirements in Chapter VI.B, the need for common AVO training was found to have a derived requirement of common AVO HMI for control of the air vehicle. This common HMI also needs to be in the form of a directed type AVO interface vice a controlled AVO interface as discussed in Chapter VI.B.

The architecture also needs to separate the AVO HMI from the payload HMI to facilitate easier interface changes to the GCS. This will allow AVOs to use an interface without interdependencies on the payload HMIs that can vary so radically between air vehicle types.

Lastly, from the requirement in Chapter VI.B, use of a common mission planning tool enables all AVOs to be trained on the use of a single common interface for mission planning. This will facilitate even greater commonality in pilot training.

## **3. *Enabling Interoperability***

In addition to common AVO training, the research revealed other requirements for a common GCS architecture. An important requirement is for a level of interoperability between the GCS and different types of UAS air vehicles. This was captured in the Requirement 6 found in Table 8.

To help with interoperability, Requirements 7 and 8 found in Table 8 show that the GCS will need a common way to have data link management. This will facilitate the use of common forms of both voice and data formats that can be used by all UASs that work with the common GCS.

The architecture is designed to have separate air vehicle control to translate internal GCS system commands into a standard common control format for the UAS air vehicle. This will enable interoperability while allowing the GCS to maintain different hardware in the physical architecture and allowing the architecture to remain scalable.

## **B. ARCHITECTURAL SYNTHESIS FROM AN AIR VEHICLE CONTROL PERSPECTIVE**

The initial step in developing the architecture was to develop an external systems diagram that depicts the system, external systems, and context [Buede, 2009]. Development of the JUCCS architecture was influenced by the segregation of the HMI as a separate functional area as first seen in the BAMS architecture. The JUCCS external systems diagram illustrates the UAS, the external entities, and the relationships between the UAS and the entities as shown in Figure 27. The UAS, shown as block C0, consists of both the UAV and the GCS.

A unique approach in developing the external diagram was the inclusion of block C1, the Area of Interest (AOI), Contact of Interest (COI), and Target of Interest (TOI). None of the examined UAS architectures had included these elements although the elements communicate and exchange data and energy with the UAS. Another unique approach in the architecture development was to include the threat information in block C6. Threats can come in the form of directed energy, cyber attack (non-kinetic attacks) and physical attacks (kinetic attacks). AOIs, COIs, TOIs and the potential threats impact the requirements needed for the survivability and operational effectiveness of the UAS.

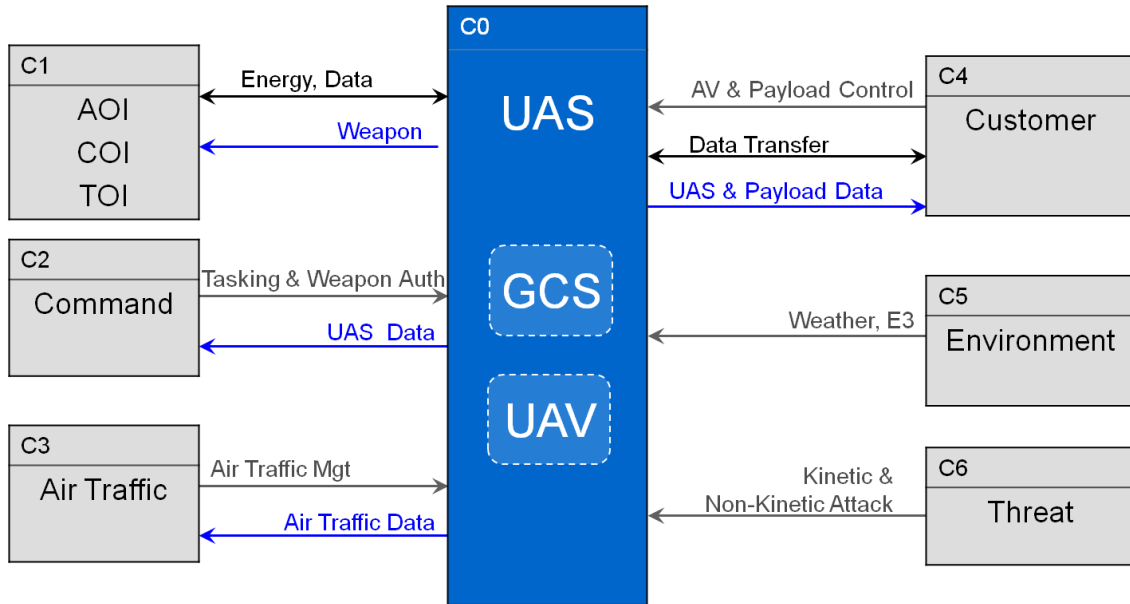

**Figure 27. JUCCS External Systems Block Diagram**

*JUCCS external systems diagram illustrating the UAS, external entities and relationships. Unique characteristics of this architecture can be seen with the inclusion of block C1 (AOI, COI, TOI) and block C6 (Threat).*

### **1. UAS Elements and Functions**

The UAS consists of two major elements, the GCS and the UAV. The GCS is the ground control component that performs all the functions to control the UAV and interfaces with external entities to ensure the mission is executed. The UAV is the mobile air element of the UAS that utilizes onboard payloads (sensors, weapons, etc.) and communications to execute the mission.

The GCS interactively communicates externally with the UAV, various command elements, air traffic control elements, and the customers. The GCS interacts and receives data and energy from the environment in the form of weather and Electromagnetic Environmental Effects (E3). The GCS may also receive energy or data from various threats.

The GCS controls piloting, navigation, and payload (sensor, weapon, etc.) functions of the UAV. The GCS operator directs the takeoff, navigation, flight path, and

landing of the UAV. The GCS controls the sensor payload of the UAV that includes sensor status, video and data control, and control of the physical operation of the sensors. The sensor payload can include EO/IR, radar, SIGINT, as well as other sensor payloads. The GCS controls the payload functions of weapon payloads of the air vehicle including: status, selection, programming, data and video, and control.

The UAV provides mobile capabilities to execute the mission. The UAV provides the following functions: 1) Communications to the GCS which include platform status, position, and control feedback. 2) Weapons and sensor status and control feedback to the GCS. Sensor data can include sensor status, video, and data such as EO/IR, radar, and SIGINT. Sensor control includes feedback from the sensors located on the UAV. Weapon data includes weapon type, status, video, and data from the weapon on or launched from the air vehicle. 3) UAV to customer communications including all sensor status, data, control, and feedback. 4) UAV to Air Traffic Control (ATC) communications where ATC information includes Identification Friend or Foe (IFF) interrogator and transponder information and sense-and-avoid information such as the Traffic Collision Avoidance System (TCAS). 5) UAV to threat sensing including constantly scanning for E3, cyber, and weapons threats. 6) UAV to AOI, COI, and TOI sensing that includes energy that is sent from or received by the UAV sensors.

## **2. *External Entities and Functions***

External entities include command elements, AOIs, COIs, TOIs, air traffic, customers, environment, and threats. A summary of the context and relationships with the UAS are described in the following paragraphs.

Command elements provide tasking and management of the UAS such as mission and reporting requirements. The command element includes strategic, tactical, and coalition command and control elements. Tasking includes communication regarding mission planning and execution. UAS status is the current operational status of the GCS and the UAV, which could include health and position data. Weapons authorization includes authorization for weapons release and weapon information that includes type,

status, data, and video. Sensor data includes sensor status, video, and data that could include EO/IR, radar, and SIGINT.

The areas and items deemed important to the UAS mission include AOIs, COIs, and TOIs. The AOIs include all large and small ground and ocean area surveillance. COIs include all specific surveillance items of interest: personnel, vehicles, weapon systems, aircraft, boats, ships, buildings, and facilities. TOIs include adversary personnel, vehicles, weapon systems, aircraft, boats, ships, buildings, and facilities. Energy transmitted to or from the UAV is any electromagnetic energy: RF, EO/IR, emitted or reflected by the UAV or AOI, COI, TOI and is detectable by the UAV sensor suite. An example of an energy flow is RF energy in the form of a radar pulse that is emitted by the UAV and reflected from a TOI back to the UAV radar sensor. Data is transmitted to or received from a COI. An example of data to and from a COI would be Blue Force Tracker data that indicates the status and position of friendly forces.

Air traffic includes all civilian and military air traffic and air traffic control elements within communications range of the air vehicle [NASA, 2010]. ATC information includes Air Traffic Management (ATM) and air traffic data. ATM includes all voice and data that affects the flight path and safety of the UAV. ATM elements include: 1) IFF interrogator and transponder information and sense and avoid information such as TCAS. 2) External entities, such as a local airport air traffic control elements that direct the UAV flight path, altitude, and heading and provide current flight safety data such as weather, air traffic, radio frequencies, and routing information. The air traffic data includes voice and data air traffic command and control information to and from the UAS ground station. The air traffic data could include Flight Service Station (FSS) information such as ATC clearances, and recordings for Notices to Airmen (NOTAMs). The FSS broadcasts aviation weather and National Airspace System (NAS) information. The station receives and processes VFR and IFR flight plans, and monitors navigation aids. In addition, at selected locations, an FSS provides an En Route Flight Advisory Service (Flight Watch), gathers weather data, and issues airport advisories. The FSS also advises U.S. Customs and Immigration of trans-border flights [NASA, 2010]. The customer element can include strategic, tactical, and coalition elements. Customer to

UAV communication includes: 1) Sensor status, video, and data that could include EO/IR, radar, and SIGINT. 2) Sensor control includes sensor control information and feedback from the sensors located on the UAV. 3) Weapons data includes weapon type, status, video, and data from the weapon on or launched from the air vehicle. 4) Weapon authority is the weapon control including launch, feedback, and programming of the weapon. Customer to GCS communications includes the following data elements: 1) Tasking is communication regarding mission planning and execution. 2) Sensor data is sensor status, video, and data that could include EO/IR, radar, and SIGINT. 3) Weapon control includes launch, feedback, and programming of the weapon.

The external environmental effects include both weather and E3. Weather affects operation of both the GCS and UAV. Weather can affect the physical operation of the UAS in temperature, rain, snow, sleet, sand, dust, wind, etc. Operation can mean the ability to operate the equipment in all weather conditions, to include communications and sensing. E3 affects both the GCS and UAV from electromagnetic effects including those emanating from: communications, jammers, radars, etc. E3 can also include large scale electromagnetic pulses from nuclear detonation as well as lightning.

The threat element can include all manner of threats that affect both the GCS and the UAV. Threats include: E3 threats from jammers and spoofers, cyber threats that include illegal hacking of networks or information either through the air or by tapping into land lines, kinetic weapons that include everything from small arms to missiles, and non-kinetic Chemical, Biological, and Radiological (CBR) threats to the GCS.

### **C. CREATING THE JUCCS FUNCTIONAL ARCHITECTURE WITH BLOCK DIAGRAMS**

The functional architecture was created from the external systems diagram by developing functions from the relationships between the GCS, UAV, and the external entities. Relevant examples were utilized from existing programs and system engineering guidance including: *The Engineering Design of Systems* [Buede, 2009], *Systems Engineering and Analysis* [Blanchard & Fabrycky, 2006], *DoD Architecture Framework* [Dam, 2006], BAMS Architecture, and notes from various NPS classes and professors.

The main functions were developed using the GCS system requirements in Chapter VI.B and the external context diagram. The first step was to decompose the UAS block of the external systems diagram into GCS and air vehicle functions as shown in Figure 28. The decomposition of the UAS system functions follow by decomposing the GCS and air vehicle functions linked to the data from the external entities in the external context diagram.

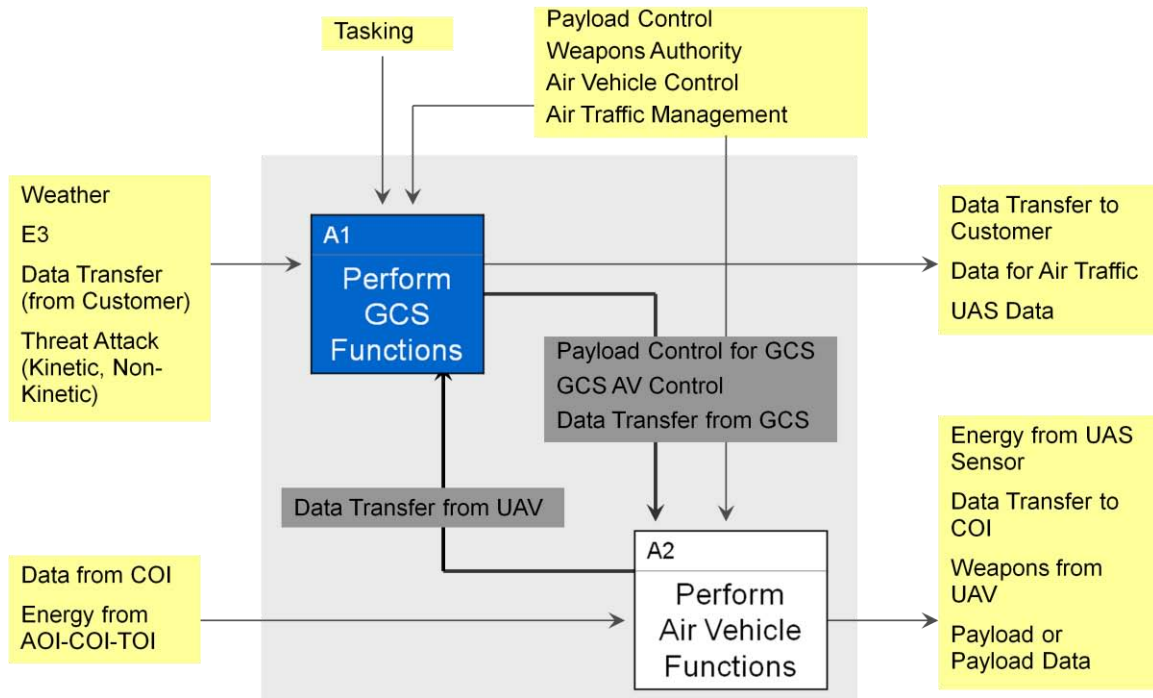

**Figure 28. JUCCS UAS Block Diagram**

*JUCCS UAS functional block diagram showing external entities, GCS and Air Vehicle Functions, and the data elements between them.*

### 1. *Top Level Hierarchy of JUCCS Architecture*

The top level hierarchal JUCCS systems diagram was developed from the external systems diagram and the context of the external elements as shown in Figure 29. The UAS was first decomposed into two functions relating to the GCS and the air vehicle. The functions of the air vehicle are not included at this time as the concentration is on the control of the air vehicle from the GCS. The GCS was further decomposed into eight sub-functions: *Provide Human Interface, Plan Mission, Manage Mission,*

*Command and Control Air Vehicle, Control Payload, Process Payload Data, Manage Communications and Disseminate Data, and Perform External Communications. Further decomposition will take place on only three of the GCS sub-functions: Provide Human Interface, Manage Mission, and Command and Control Air Vehicle. This is due to the project focus on common training by having a common HMI for air vehicle control.*

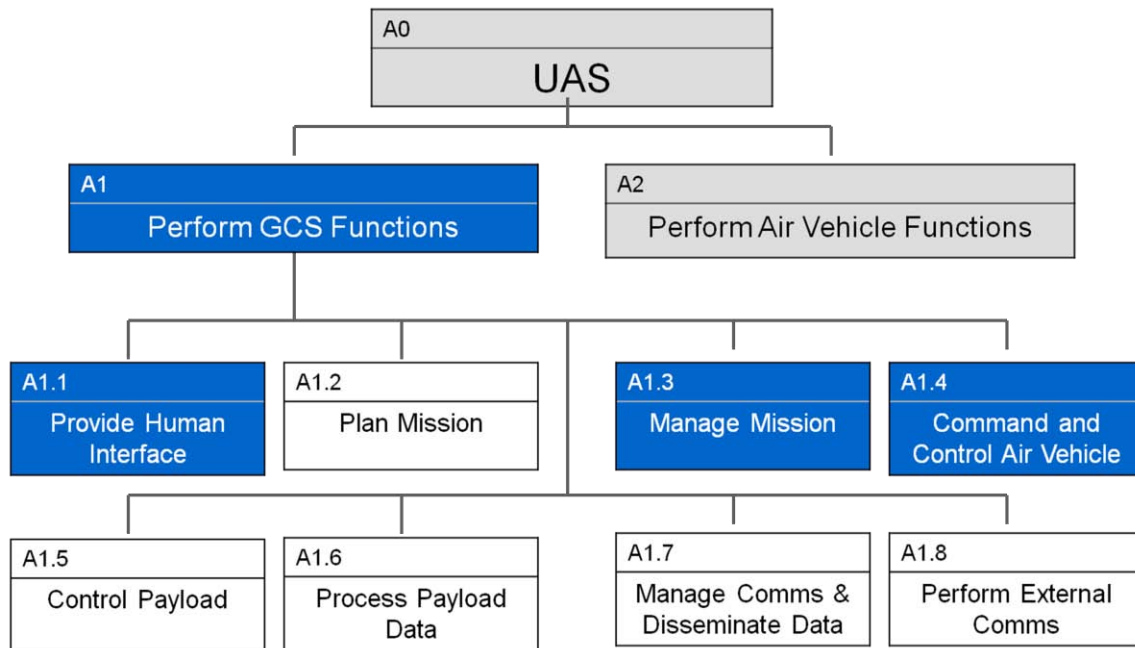

**Figure 29. JUCCS Architecture Top Level Hierarchy**

*JUCCS Architecture highlighting the emphasis on the GCS functions, including the Provide Human Interface, Manage Mission and Command and Control Air Vehicle functional elements. Blocks shown in blue are further decomposed in the architecture.*

## 2. *A1 Block Diagram: Perform GCS Functions*

The A1 diagram is the main functional component for a common GCS. There are external entities that feed data to the GCS including the air vehicle which is internal to the system, and various external entities. The main functional architecture of the GCS is made up of eight functions. These functions can be seen in the following list and in Figure 30.

- *A1.1 Provide Human Interface*
- *A1.2 Plan Mission*
- *A1.3 Manage Mission*
- *A1.4 Command and Control Air Vehicle*
- *A1.5 Control Payload*
- *A1.6 Process Payload Data*
- *A1.7 Manage Comms and Disseminate Data*
- *A1.8 Perform External Comms*

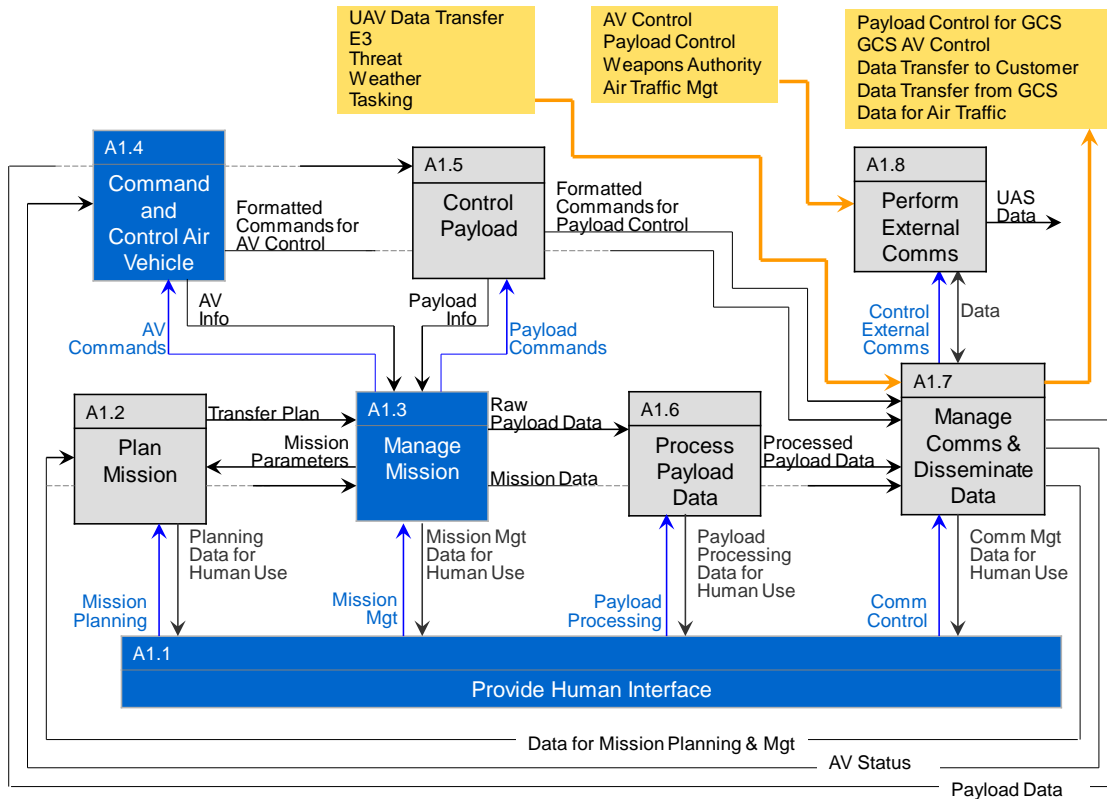

**Figure 30. JUCCS Perform GCS Functions Block Diagram**

*This diagram shows the eight functions that comprise the Perform GCS functions and their associated data flows. Blocks shown in blue are further decomposed in the architecture.*

*A1.1 Provide Human Interface* is the function that provides all the interaction between the system and the human operators. All of the system human interfaces from

system output to the operator (visual, aural, or tactile) and inputs to the system through input devices (mouse, keyboard, joystick, etc) are functionally modeled here. This is the function that interacts with the rest of the system through the functions A1.2, A1.3, A1.6, and A1.7.

*A1.2 Plan Mission* is the mission planning function. One of the derived requirements for common training is that a common mission planning system be used and mandated through a common GCS. This function is separate and its own functional module to ensure that a new mission planning system can be changed in the architecture.

*A1.3 Manage Mission* is the function that is the central point of the system operations. It takes in the information from the air vehicle including aircraft telemetry, AV system status, payload status, payload data, mission plan information, and then uses those to interpret the operator input from *A1.1 Provide Human Interface*. A1.2 is where the system keeps track of the air vehicle, where it is, what it is doing, and allows the operator commands to occur.

*A1.4 Command and Control Air Vehicle* provides the translator function taking internal system commands and converting them to a standard interoperable language that all UAVs can understand. This will address the requirement for interoperable AV control. This function is also modular and separate from the payload control to ensure that either function can be changed in the physical architecture without having interactions change with the other to meet the requirement of separating the AV control and the payload control.

*A1.5 Control Payload* is the function that allows control of the payloads. These payloads can be sensors, weapons, or other devices. The need here is to separate the payload control from the AV control as payloads can vary widely from air vehicle type to type. This function translates the specific system commands to the payload commands necessary for that type of payload. This allows specific changes in this functional module to be more readily changed when payloads are changed.

*A1.6 Process Payload Data* allows for the raw payload data from different payloads to be manipulated by the operator. The raw data is input to the function and the operator can change the metadata, format, or fuse with other information. An example of this could be taking a Synthetic Aperture Radar (SAR) image and marking targets of interest or associating electro-optical imagery with geographic locations.

*A1.7 Manage Comms and Disseminate Data* is a function that controls what data leaves the GCS. It directly handles information internal to the system (between the GCS and the AV) and governs the format and data type. For communications external to the system, the recipient and data is sent to *A1.8 Perform External Comms*.

*A1.8 Perform External Comms* takes data from the *A1.7 Manage Comms* and will format and send to the directed external entity. This function allows the separation of communication functionality between those that are internal to the system (between GCS and the AV) and those that are between the GCS and other entities external to the GCS. It needs to be noted that some communications from the air vehicle to other external entities are still handled in the GCS by *A1.7 Manage Comms* because some communications data can be ported to the air vehicle and then transmitted from the air vehicle to entities external to the system.

#### **D. DOCUMENTING AND LINKING THE ARCHITECTURE WITH CORE<sup>®</sup>**

The JUCCS architectural team realized that a Model Based Systems Engineering (MBSE) tool would be beneficial due to the complexity of the proposed functional architecture. There are several MBSE tools available for systems engineering design and two common choices are Vitech Corporation's CORE<sup>®</sup> and IBM's Rational System Architect. The JUCCS architectural team chose CORE<sup>®</sup> since a student license was already established from earlier NPS classes and the JUCCS architecture team was familiar with the basic operation of the CORE<sup>®</sup> software. CORE<sup>®</sup> Enterprise version 5.1.5 was used to document the JUCCS functional architecture. The JUCCS architectural team used the formerly described architectural synthesis to identify the boundaries between the UAS and the external environment.

The CORE<sup>®</sup> software allows the use of either Enhanced Functional Flow Block Diagrams (EFFBD) or the Integration Definition for Functional Modeling (IDEF0) as an architectural format. The EFFBD is used “for capturing dynamic behavior in a representation that can be simulated” [Buede, 2009]. IDEF0 is a process model which addresses “how outputs are transformed from inputs via some function, activity, or task” [Buede, 2009]. The complex interaction between multiple functions within the UAS is more suited to the functional and non-linear IDEF0 format, so this is the format that was chosen by the JUCCS architectural team.

The IDEF0 format consists of several functional blocks per diagram, and each block can consist of four activities. These activities consist of the Inputs, Controls, Outputs, and Mechanisms (ICOM). The input is an activity flow that enters the functional block from the left. The control has an effect on the function and enters the block from the top. The output captures what the function has done and exits the block from the right. Finally the mechanism, although not used in the JUCCS functional architecture, is an external entity that can affect the function. It is recommended that each functional level contain three to six functional blocks. Some of the JUCCS IDEF0 diagrams consist of as many as eight functional blocks and as few as two. The JUCCS architectural team determined these variations from the IDEF0 recommendations were warranted in order to properly describe the corresponding functions [Knowledge Based Systems, Inc., 2010].

During the initial design, each of the major functions within the UAS system was defined based on the functional requirements detailed in Chapter VI.B. These major functions provided the backbone for the JUCCS functional architecture and it was during this initial design that the CORE<sup>®</sup> software proved useful. When data flow linkages between functions at different levels were not consistent the CORE<sup>®</sup> software provided indications of the inconsistencies. The inconsistencies could then be adjudicated and corrected to allow consistent functional flow.

Additionally, further usefulness of the CORE<sup>®</sup> software was realized when editing and making changes to the functional architecture. An artifact of using the

CORE<sup>®</sup> MBSE tool is that changes made at one level were properly reflected at lower levels or an indicator identified an inconsistency. Since the JUCCS functional architecture went through seven major revisions, the tool enabled the JUCCS architectural team to quickly and accurately make changes that would have been difficult to track if an MBSE tool was not used.

## **E. JUCCS PROPOSED COMMON GCS ARCHITECTURE**

As discussed, the architectural views were developed using an IDEF0 approach. The IDEF0 functions were decomposed only to the level needed to show the air vehicle control functions and to those levels necessary to show that the requirements in Chapter VI.B for common training are demonstrated by the architecture. Each sub-function was then modeled in IDEF0 to ensure consistent data flow between levels.

### ***1. A-1: External Systems Diagrams***

The initial context diagram, shown in Figure 27, was modeled in IDEF0. This was accomplished by creating an external system diagram, shown in Figure 31, and defining the different data flows between the elements. The IDEF0 version of the original diagram results in a greater resolution of what data flows between elements and in what direction that data flows.

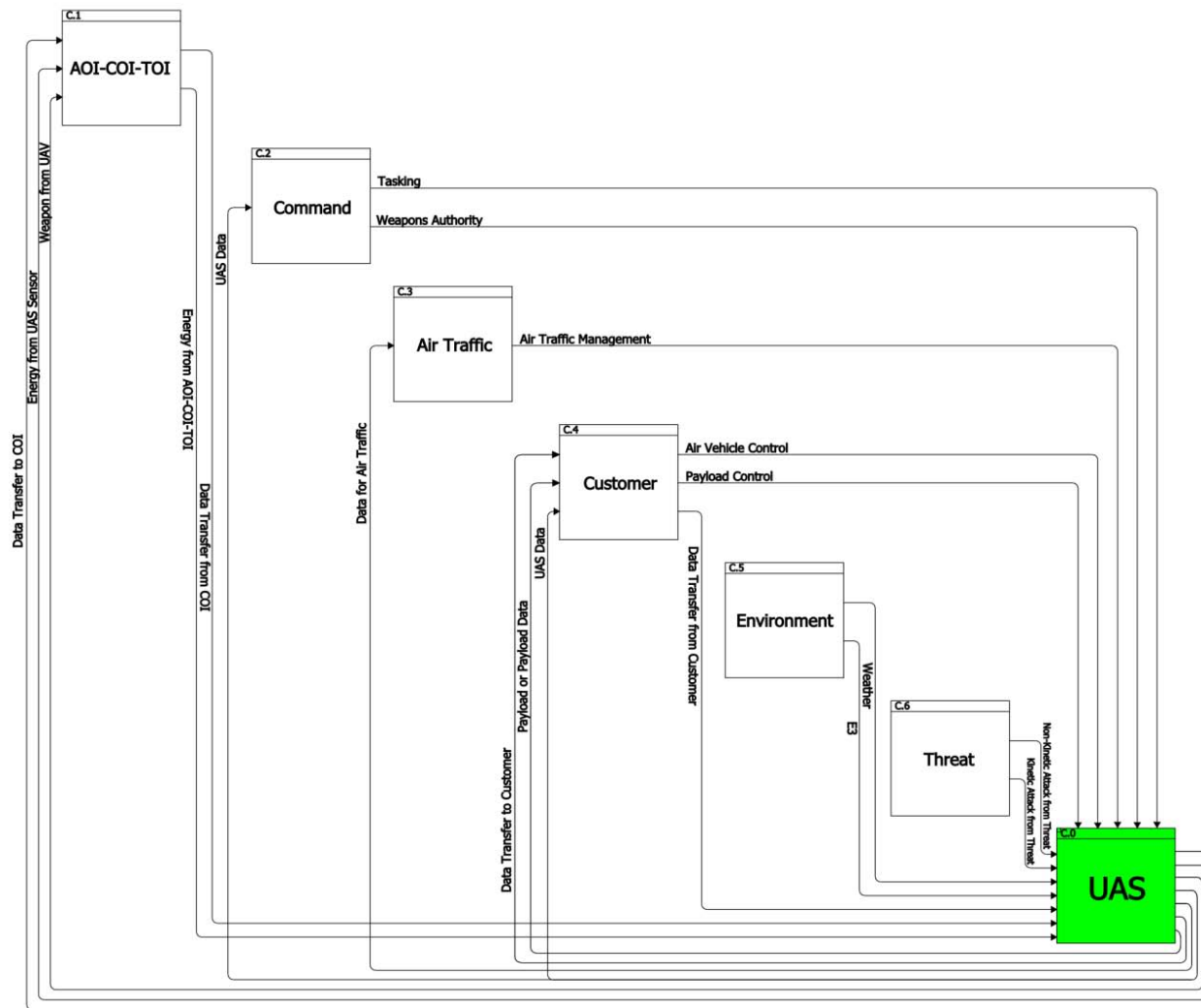

**Figure 31. JUCCS IDEF0 A-1 External Systems Diagram**

*The external context diagram in IDEF0 format shows the external entities that are outside the system (C0) and how they interact with the system. The block shown in green (UAS) has been further decomposed in the architecture.*

As discussed, the A-1 external diagram here is the IDEF0 version of Figure 27. The descriptions of each of the external entities and how they interact with diagram have already been discussed and can be found in Chapter VII.C.

## 2. A0: UAS Node Diagram

The A0 JUCCS UAS node diagram was modeled in IDEF0 as shown in Figure 32. This was accomplished by taking the JUCCS UAS block diagram shown in Figure 28 and defining the different data flows between the elements. The IDEF0 version of the diagram results in a greater resolution of what data flows between elements and in what direction that data flows.

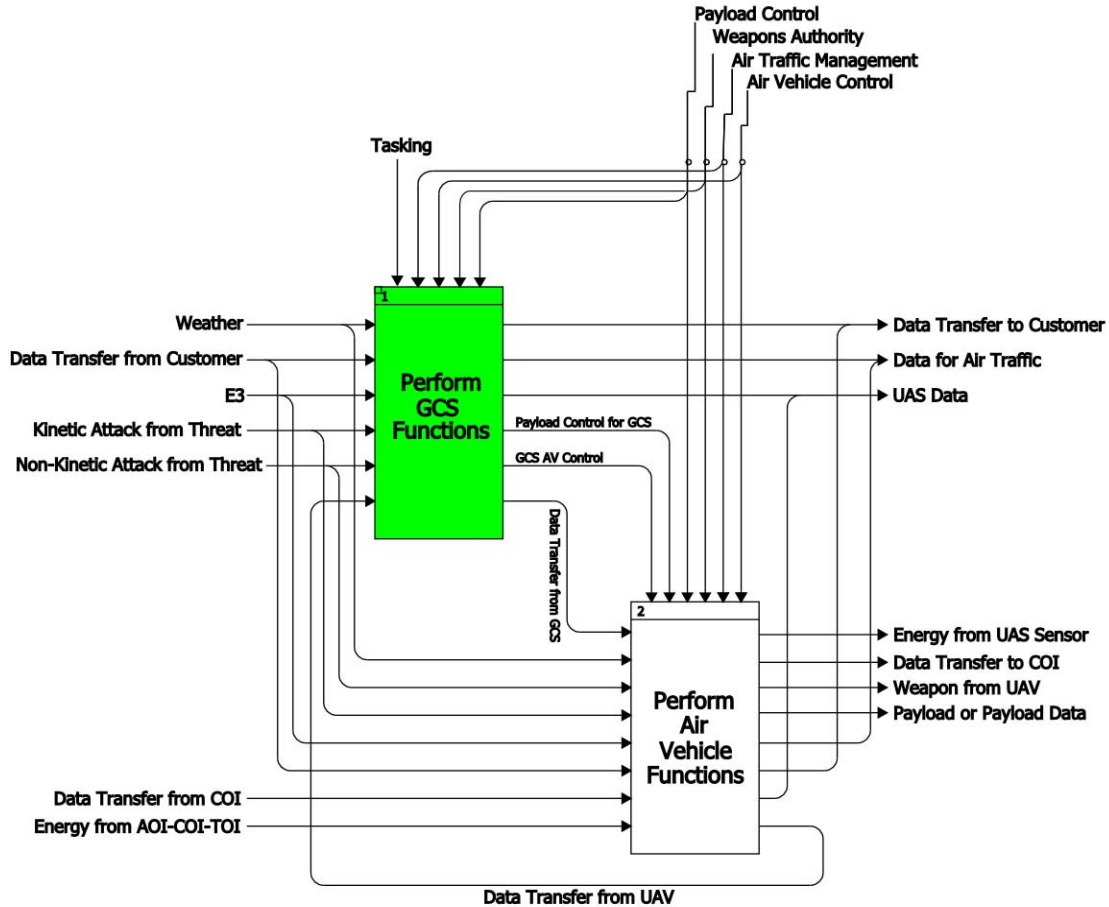

**Figure 32. JUCCS IDEF0 A0 UAS Node**

*This diagram shows the two internal nodes of the A0 system diagram. They include the Air Vehicle and the Ground Control Station functions. Only the Ground Control Station functions shown in the green block will be decomposed in this architecture.*

The IDEF0 A0 diagram shows the two functions of the UAS as a whole system. They are the *Perform Ground Control Station Functions* and the *Perform Air Vehicle Functions*. The descriptions for these functions are located in Chapter VII.C.1. The information flows from the A-1 external nodes are shown in the diagram. They represent the interactions of the external entities with both functions of the UAS, as well as how the two functions of the UAS pass data between the *Perform GCS Function* and the *Perform Air Vehicle Function*.

### 3. *A1: Perform GCS Functions*

*Perform GCS Functions* details the overall system functions for the GCS. The IDEF0 diagram of *A1 Perform GCS Functions* can be seen in Figure 33. This IDEF0 depiction shows all of the data flows between the GCS functions. It is important to see that all communication from the air vehicle comes through *A1.7 Manage Comms*. This includes things that are transmitted to the air vehicle from sources external to the system and then sent from the air vehicle to the GCS. All communication that arrives at the GCS from sources external to the system arrives through *A1.8 Perform External Comms*.

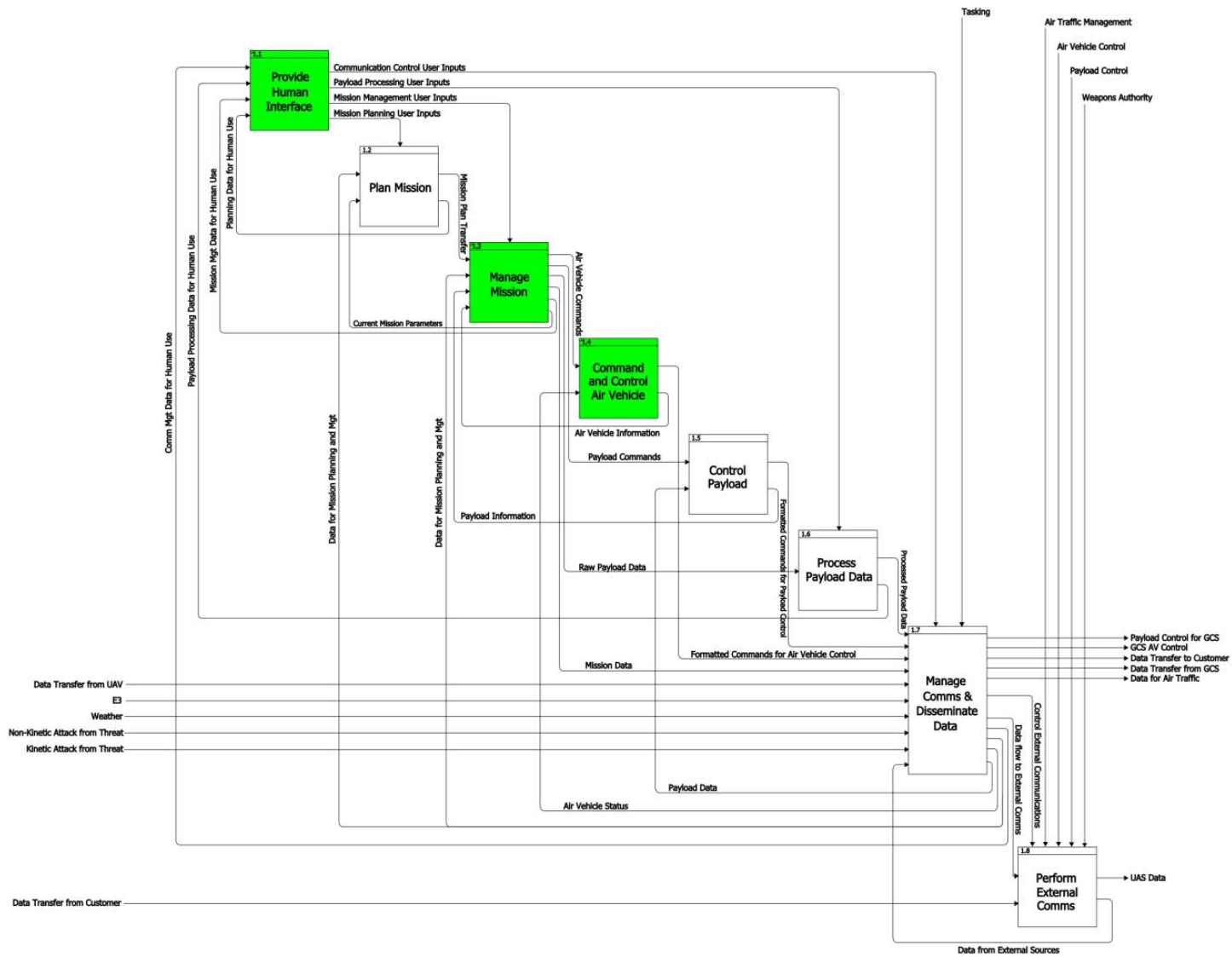

**Figure 33. JUCCS IDEF0 A1 Perform GCS Functions**

*This IDEF0 diagram shows the eight functions that comprise the Perform GCS functions and their associated data flows. The blocks shown in green have been further decomposed in the architecture.*

The IDEF0 A1 diagram shows the eight functions of the GCS as a system. The descriptions for these functions are located in Chapter VII.C.2. The information flows from the A0 external nodes and from the *Perform Air Vehicle Functions* node are shown in the diagram. They represent the interactions of the external entities with the GCS functions as well as how the two functions of the UAS pass data between them.

#### **4. *A1.1: Provide Human Interface***

The *A1.1 Provide Human Interface* function is a top level GCS function. It breaks out the human machine interface for all operator actions into a separate function. The functional architecture of the *Provide Human Interface* is made up of six functions:

- *A1.1.1 Perform Security and Role Based Access*
- *A1.1.2 Provide HMI Setup Management*
- *A1.1.3 Provide Mission Planning Interface*
- *A1.1.4 Interface with Mission Management Control*
- *A1.1.5 Provide Payload Data Processing Interface*
- *A1.1.6 Provide Communication and Data Dissemination Interface*

Of these functions, *A1.1.4 Interface with Mission Management Control* will be decomposed further to show the AVO human-machine interface. These six functions can be seen in context in Figure 34.

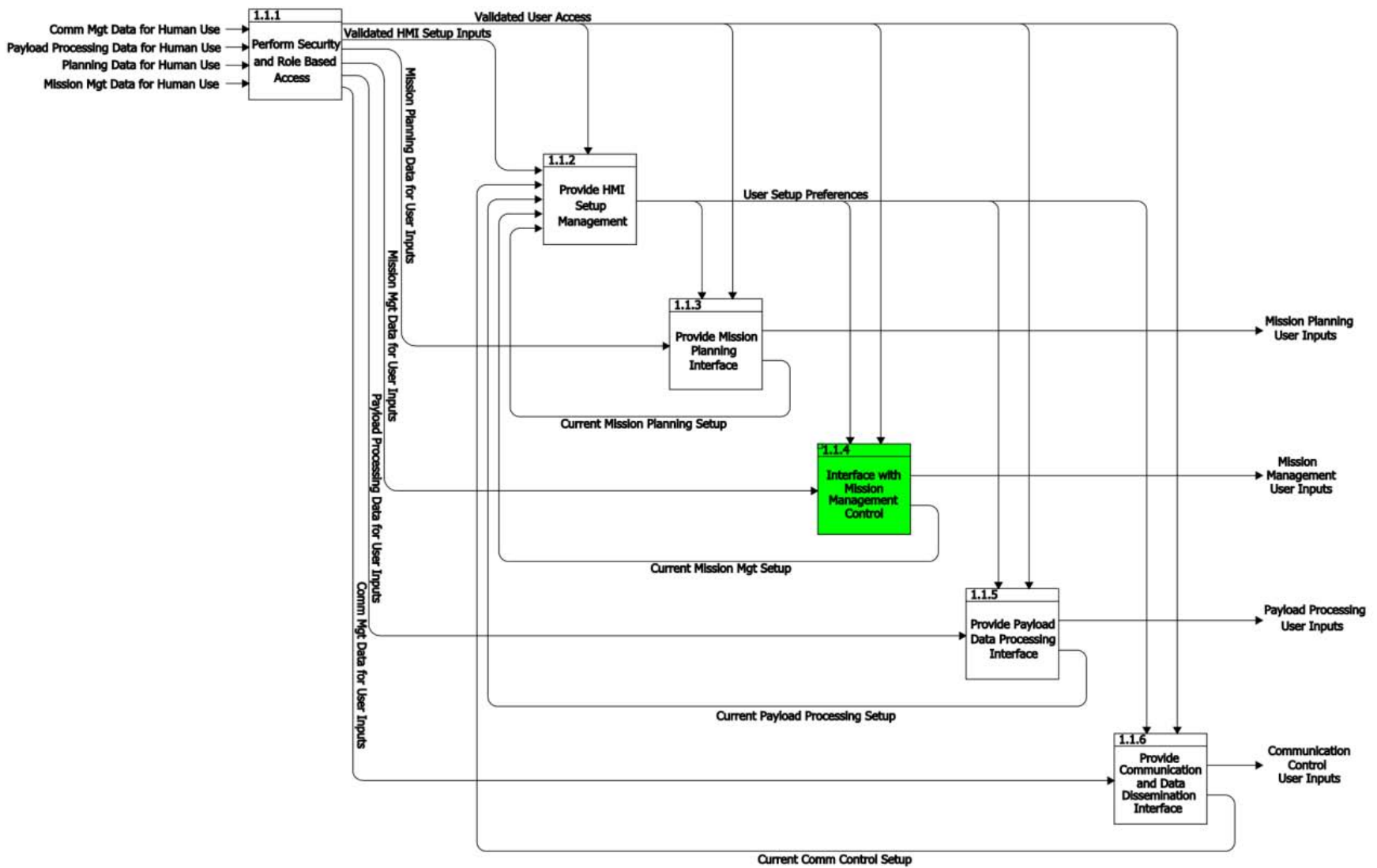

**Figure 34. JUCCS IDEF0 A11 Provide Human Interface**

*The Provide Human Interface function allows all the operator interfaces to be grouped together in one functional group. 1.1.4 Interface with Mission Management Control will be further decomposed to show the AVO Human-Machine Interface.*

*A1.1.1 Perform Security and Role Based Access* is the function that provides the interface to log into the system. The function will then ensure that the person has the security clearance to use the system. It will then find the role that allows that operator to access certain functions and therefore certain HMI functions and not others depending on the role that has been set up for that person. It will provide the user access to the other functions in A1.1 to allow for their use through the validated user access data. The function will allow the pass through of mission data through the A1.1.1 to the other functions.

*A1.1.2 Provide HMI Setup Management* is the function that allows a validated user to change the way information is presented to them. It can allow for setting of parameters such as the volume or tone of aural information. It can allow the setting of parameters such as the colors or size of visual information. It can also allow the setup of parameters for tactile information such as vibration frequency or amplitude of a controller or chair. It could also allow setup of the input devices such as cursor scroll rate, etc.

*A1.1.3 Provide Mission Planning Interface* is the function that provides the interface for the mission planning function of the GCS. It will allow the HMI to the authorized operator to plan the UAS AV mission plan and transfer the data to the function *A1.2 Plan Mission*.

*A1.1.4 Interface with Mission Management Control* is the function that provides the interface for *A1.4 Manage Mission*. Inside of this functional area the HMI for the AVO interface necessary to meet the JUCCS requirement 1, 2, 3, and 4 are located. This function will be further decomposed as shown in Figure 35.

*A1.1.5 Provide Payload Data Processing Interface* is the function that provides the HMI for the *A1.6 Process Payload Data*. This interface will control how the raw payload data is manipulated, annotated, and fused by the operators.

*A1.1.6 Provide Communication and Data Dissemination* is the function that provides the HMI for the *A1.7 Manage Comms and Disseminate Data*. This function

allows for the selection of data transmission paths, carrier frequencies, etc. to flow to the UAS AV and to sources external to the GCS.

The decomposition of *A1.1.4 Interface with Mission Management Control* can be seen in Figure 35.

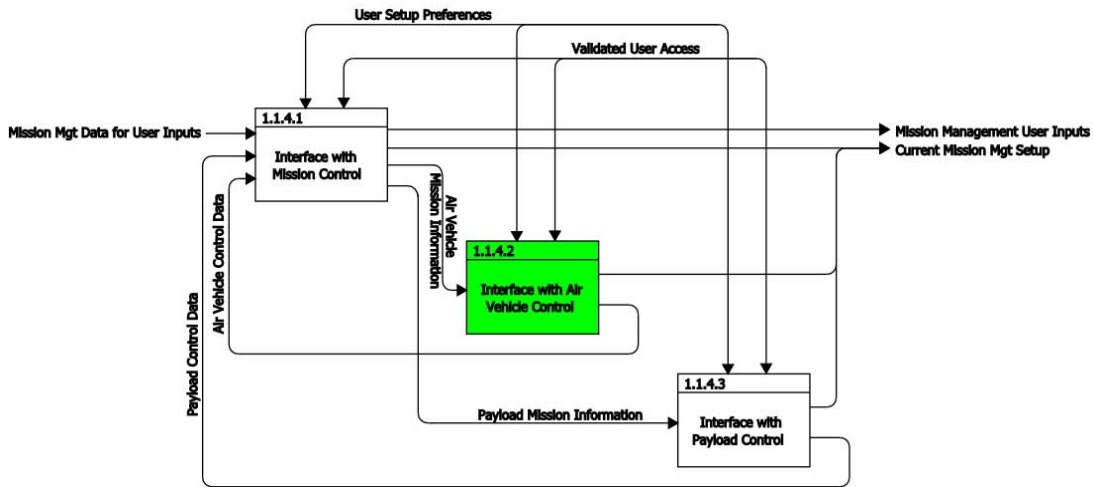
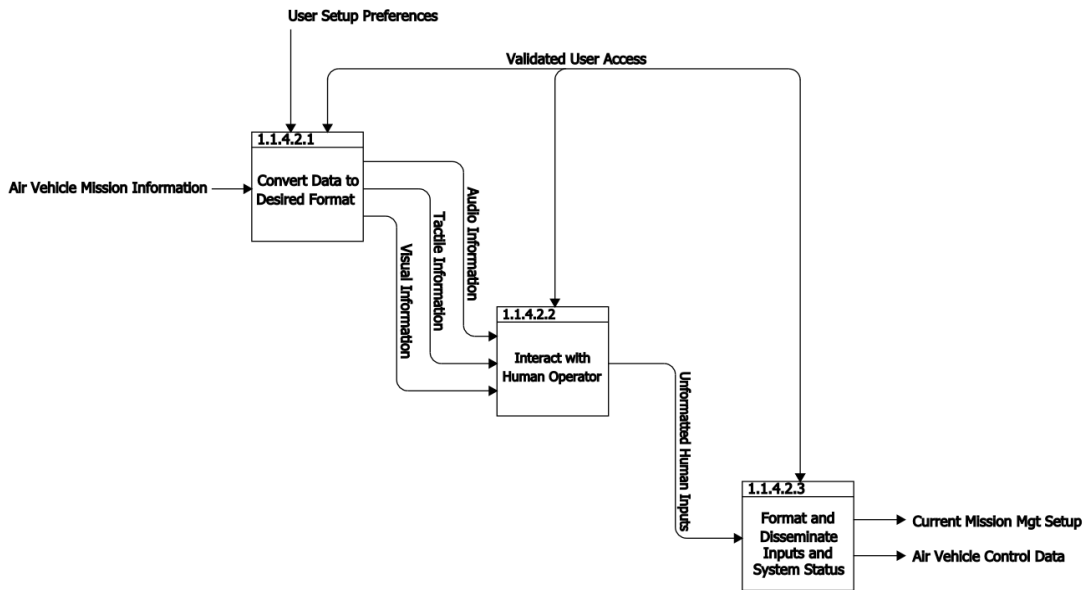

**Figure 35. JUCCS IDEF0 A114 Interface with Mission Management Control**

*The Interface with Mission Management Control IDEF0 diagram shows the operator interface for mission, air vehicle and payload control. The block shown in green is further decomposed in the architecture.*

The *A1.1.4 Interface with Mission Management Control* IDEF0 diagram shows the interaction between the JUCCS common HMI and the mission management functions. Mission management functions consist of the operator interface for mission, air vehicle and payload control. The user setup preferences control input consists of that specific operator’s stored preferences. The specific operator is authenticated using the validated user access control to ensure air vehicle commands only come from authorized operators. The *A1.1.4.1 Interface with Mission Control* functional block provides the main input linkage and parses out the air vehicle or payload control as required. The center function, *A1.1.4.2 Interface with Air Vehicle Control* functional block, is shown in green and is further decomposed to show how common air vehicle training benefits can be realized by this function. The *A1.1.4.3 Interface with Payload Control* functional block provides the operator interface for controlling the specific payload. Due to the

multiple different types of payloads which consist of weapons and sensors and their proprietary nature, this was not a function where the JUCCS architectural team focused their attention in order to realize commonality.



**Figure 36. JUCCS IDEF0 A1142 Interface with Air Vehicle Control**

*The Interface with Air Vehicle Control IDEF0 diagram is the lowest decomposition of the operator interface with the air vehicle. The actual human operator resides within the Interact with Human Operator functional block shown in the center as 1.1.4.2.2.*

The *A1.1.4.2 Interface with Air Vehicle Control* IDEF0 diagram consists of the functions that deal with how the current air vehicle mission information is presented to the operator. The user setup preferences control input consists of that specific operator’s stored preferences. The specific operator is authenticated using the validated user access control to ensure air vehicle commands only come from authorized operators. The *A1.1.4.2.1 Convert Data to Desired Format* functional block translates the air vehicle information to audio, visual or tactile information, or any combination of the three, depending on what is appropriate for that particular data and the operator’s preferences. This translated air vehicle information is provided to the *A1.1.4.2.2 Interact with Human Operator* functional block which is where the human operator resides. The human operator then makes decisions and provides unformatted inputs, through system input

devices such as a keyboard, mouse, joystick, touch-screen, etc. This unformatted data is sent to the *A1.1.4.2.3 Format and Disseminate Inputs and System Status* functional block which translated the unformatted input into an air vehicle or mission management command. An example of this translation would be the raw keyboard data being translated from the American Standard Code for Information Interchange (ASCII) to the specific command, in its native format, going to the air vehicle, based on the operator's keystrokes. An additional output from the *A1.1.4.2.3* functional block is the detection of the operator's current mission setup features which are fed back up into the *A1.1.2 Provide HMI Setup Management* functional block where the settings are stored for this operator's future use.

## 5. *A1.3: Manage Mission*

The *A1.3 Manage Mission* function is a top level GCS function. It is the central function that the GCS system works through. The function takes current information from the UAS AV status, payload information, mission plan, and uses inputs from the operator to send commands out to the system. The functional architecture of *Manage Mission* is made up of four functions:

- *A1.3.1 Monitor Mission*
- *A1.3.2 Assess Mission*
- *A1.3.3 Update Mission*
- *A1.3.4 Direct System*

Of these functions, the *A1.3.4 Direct System* interface with *A1.4 Command and Control Air Vehicle* is necessary to send commands to the UAS AV to meet JUCCS Requirement 6 and 7. These four functions can be seen in context in Figure 37.

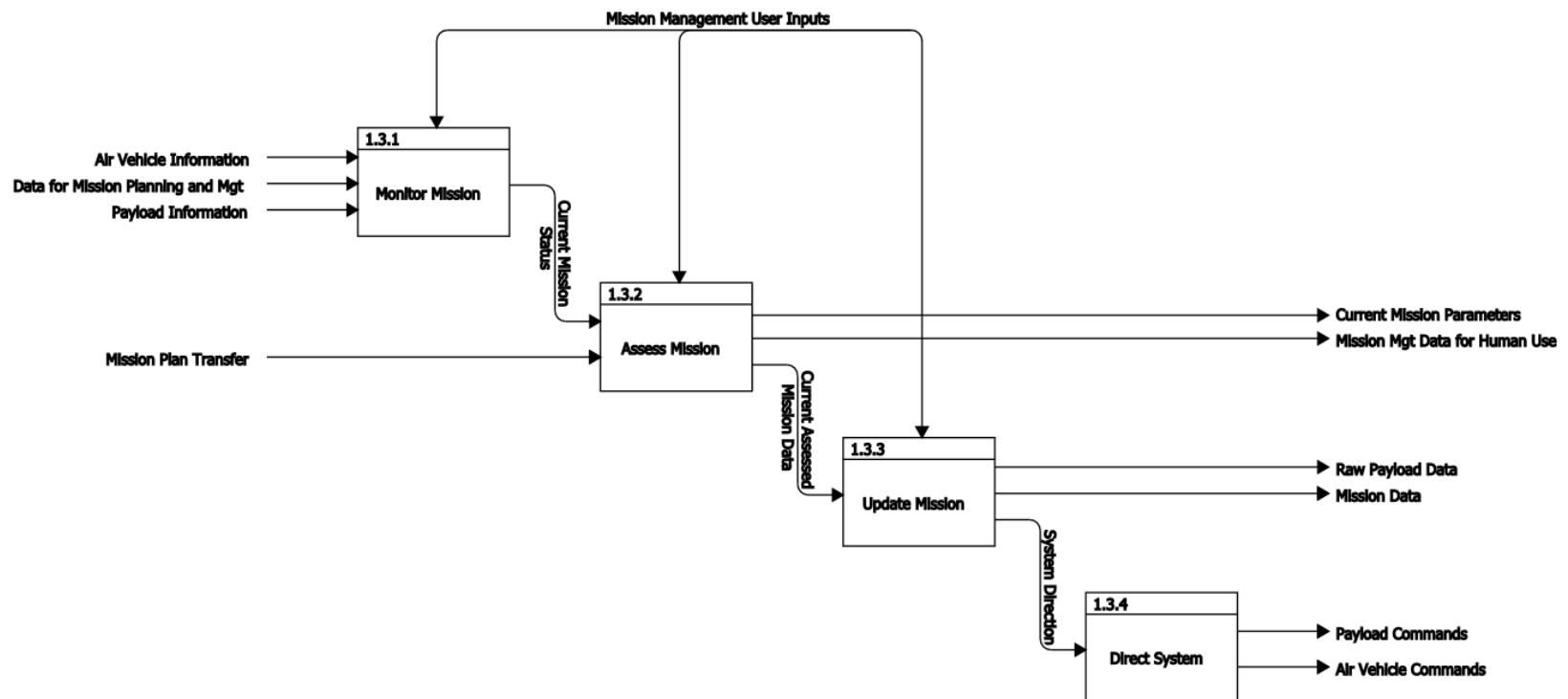

**Figure 37. JUCCS IDEF0 A13 Manage Mission**

*The Manage Mission IDEF0 functional diagram provides the Monitor Mission and Assess Mission functions. Based on the payload or air vehicle operator updated commands, the payload or air vehicle is provided with updated commands if required.*

The *A1.3 Manage Mission* IDEF0 functional diagram shows the JUCCS architecture's four major mission functions. The *A1.3.1 Monitor Mission* functional block accepts air vehicle information, raw payload information from the weapon or sensor, and data for mission planning and management as input from the *A1.2 Plan Mission* function. This information is translated and allows the operator to assess the mission at the *A1.3.2 Assess Mission* functional block. The *Assess Mission* function also allows for input of the mission plan and outputs the current mission parameters and the mission management data for human use which feeds back into the HMI. The output from *A1.3.2* is the current assessed mission data from the operator which is input into the *A1.3.3 Update Mission* functional block where the operator makes mission changes based on the current data. The output from *A1.3.3* is the raw payload data, which is sent to the *A1.6 Process Payload Data* functional block, and the mission data, which is sent to the *A1.7 Manage Comms & Disseminate Data* functional block. The final output from *A1.3.3* is the system direction command which is the input to the *A1.3.4 Direct System* functional block. The *Direct System* functional block then formats the appropriate commands for the air vehicle (which is an input to *A1.4 Command and Control Air Vehicle*) and the payload (which is an input to *A1.5 Control Payload*).

## **6. *A1.4: Command and Control Air Vehicle***

The *A1.4 Command and Control Air Vehicle* function is shown in Figure 38. It is important to see that the two sub-functions here are both transfer functions that translate system specific commands into a standard set of command controls to facilitate JUCCS Requirements 6 and 7 found in Table 8.

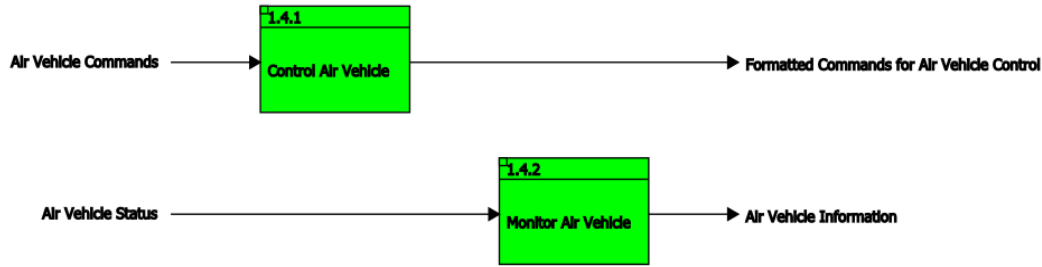
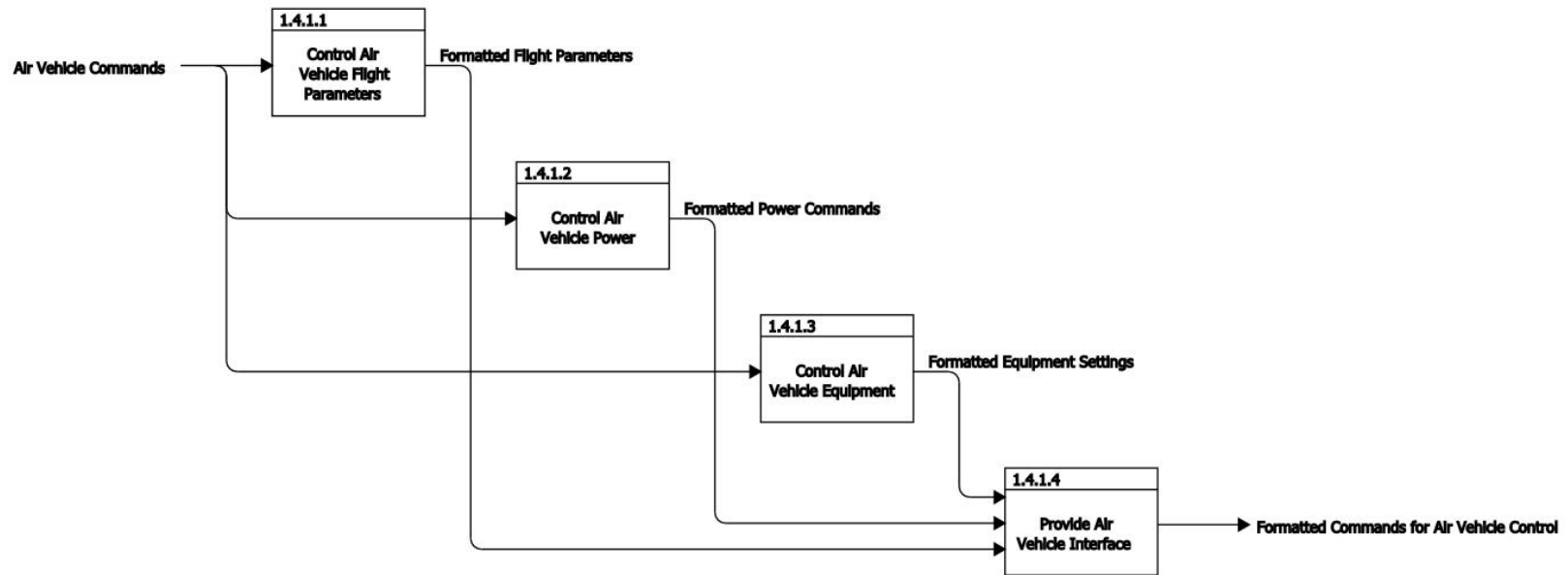

**Figure 38. JUCCS IDEF0 A14 Command and Control Air Vehicle**

*The JUCCS IDEF0 Command and Control Air Vehicle is where the proprietary command enters the Control Air Vehicle functional block and is translated into a standard command output (an example of which would be the STANAG 4586 interoperable formatted commands) on the output. Similarly the formatted air vehicle status data enters the Monitor Air Vehicle functional block and is translated to its proprietary air vehicle information for use in the GCS. Both of these blocks are decomposed further.*

The *A1.4 Command and Control Air Vehicle* IDEF0 diagram consists of the *A1.4.1 Control Air Vehicle* and *A1.4.2 Monitor Air Vehicle* functional blocks. While the main purpose of these functional blocks is to control and monitor the air vehicle, here is where the main tenets of STANAG 4586, a common standard format for UAV control external to the GCS, can be realized. Formats, however, are not limited to STANAG 4586. For instance the *A1.4.1 Control Air Vehicle* functional block receives the proprietary (e.g. Boeing, Northrop Grumman, etc.) air vehicle commands and translates them from a proprietary air vehicle language into standard formatted commands for the air vehicle. This translation is conducted through the use of software subroutines that perform the translation within the *Control Air Vehicle* functional block. Similarly the *A1.4.2 Monitor Air Vehicle* functional block translates the common standard formatted air vehicle status and converts it to the native system language within the GCS. These two translation functional blocks allow for the commonality and interoperability that STANAG 4586 and the 2009 USD(AT&L) ADM are requesting.

The *A1.4.1 Control Air Vehicle* function is shown in Figure 39.

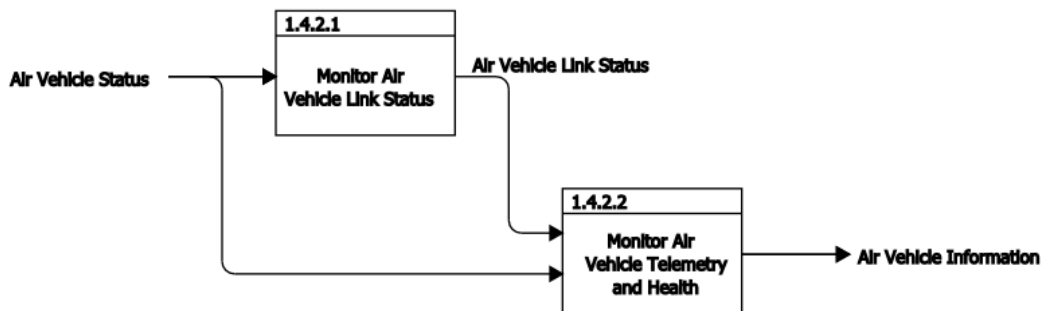

**Figure 39. JUCCS IDEF0 A141 Control Air Vehicle**

*The JUCCS Control Air Vehicle IDEF0 diagram shows the functional blocks responsible for formatting flight parameters, electrical power settings and specific avionics equipment settings from the proprietary language into a common standard formatted commands.*

The *A1.4.1 Control Air Vehicle* IDEF0 diagram provides further decomposition of the *Control Air Vehicle* functional block. The *A1.4.1.1 Control Air Vehicle Flight Parameters* functional block accepts the proprietary air vehicle commands that relate to flight parameters, such as climb to a certain altitude or proceed to a certain waypoint, and translates them into a standard STANAG 4586 formatted flight parameter. The *A1.4.1.2 Control Air Vehicle Power* functional block accepts the proprietary air vehicle commands that relate to vehicle power management and translates them into a standard STANAG 4586 formatted command. An example of this functional block in operation is turning off the external lights, radios and payload power in the event of an emergency generator failure to conserve battery power for flight control surface movement required for the emergency landing. The *A1.4.1.3 Control Air Vehicle Equipment* functional block accepts the proprietary air vehicle commands that relate to equipment settings and translates them into a standard STANAG 4586 formatted command. An example of this functional block is setting the IFF codes provided by ATC or changing communications frequencies. The *A1.4.1.4 Provide Air Vehicle Interface* functional block accepts the three standard STANAG 4586 formatted commands (flight parameters, power commands, and equipment settings) and prioritizes and queues these commands for transmission to the air vehicle through the *A1.7 Manage Comms & Disseminate Data* functional block.

The *A1.4.2 Monitor Air Vehicle* function is shown in Figure 40.



**Figure 40. JUCCS IDEF0 A142 Monitor Air Vehicle**

*The JUCCS Monitor Air Vehicle IDEF0 diagram performs the translation of the input standard (such as STANAG 4586) formatted air vehicle status messages and translates these messages to the native system's proprietary language making interoperability possible. The link status is also monitored for usability.*

The *AI.4.2 Monitor Air Vehicle* IDEF0 diagram shows the two functional blocks that monitor the air vehicle link, telemetry and health. The *AI.4.2.1 Monitor Air Vehicle Link Status* functional block receives the standard STANAG 4586 formatted status message, checks the data link status for proper operation, and then translates the status message into the proprietary native language. The *AI.4.2.2 Monitor Air Vehicle Telemetry and Health* functional block receives the standard STANAG 4586 formatted air vehicle telemetry and health status message and translates these messages to the proprietary native language. The native air vehicle telemetry and health status message is then queued and added to the native air vehicle data link status and disseminated as native air vehicle information to the *AI.3 Manage Mission* functional block.

## **F. SUMMARY OF JUCCS ARCHITECTURE AND LINKAGE TO REQUIREMENTS**

The JUCCS common architecture requirements were derived in Chapter VI.B from NAVAIR program and other UAS documentation. The requirements were tabulated and relationships were linked from the JUCCS common architecture. Each requirement was related to the functional architecture in order to trace the requirements of the system to the initial requirements stated in the ADM. Table 9 shows the requirements linkage to the functional architecture.

**Table 9. Linkage of JUCCS Architectural Elements to Requirements**

*This table shows the linkages between the JUCCS architectural elements and the requirements that were defined earlier in the report. The table shows that some of the requirements are directly met by specific functional blocks while others are indirectly met by the overall methodology used in the architecture.*

| <b>Common Architecture Requirement</b>  | <b>Linkage to JUCCS Proposed Common Architecture</b>  |
|---|---|
| <p>1. The Ground Control Station (GCS) shall enable Air Vehicle Operator (AVO) training commonality across multiple Unmanned Aircraft System (UAS) platforms.</p> | <p>Requirement 1 will be fulfilled when the derived requirements 2-5 are satisfied.</p>   |
| <p>2. The Ground Control Station (GCS) shall have a common Human-Machine Interface (HMI) for Air Vehicle Operator (AVO) functions.</p>                            | <p>Function A1.1.4.2 Interface w/ Air Vehicle Control found inside of A1.1 Provide Human Interface allows the architecture to meet requirement 2. The interface is made standard through a single AVO interface in the common GCS architecture. This will allow the training of AVOs of different UAS air vehicles in a single way of entering commands for the air vehicle into the GCS. This means a single type of training can be developed and AVOs will be able to operate different types of air vehicles.</p> |
| <p>3. The Ground Control Station (GCS) shall allow for directed vice controlled air vehicle operation.</p>  | <p>Function A1.1.4.2 Interface w/ Air Vehicle Control allows for the air vehicle controls to be designed as directed controls so that they are common from air vehicle to air vehicle. Using controlled inputs (flight control stick, rudder and throttles) would still lead to differences in how each vehicle was given inputs, but by being a directed control system, all the commands can be taught the same way.</p>  |
| <p>4. The Ground Control Station (GCS) shall allow for separate Human-Machine Interfaces (HMI) for payload and air vehicle control.</p>                           | <p>The structure of A1.1.4 Interface with Mission Management Controls specifically breaks out air vehicle controls from payload controls. It is important in this architecture that the air vehicle control be isolated from the payload control. Payloads can vary greatly in function and operation from air vehicle to air vehicle type. The AVO controls however should be and can be the same, and this separation of the functions becomes necessary.</p>   |

**Table 9. Linkage of JUCCS Architectural Elements to Requirements (continued)**

| <p><b>Common Architecture Requirement</b></p>   | <p><b>Linkage to JUCCS Proposed Common Architecture</b></p>  |
|---|--|
| <p>5. The Ground Control Station (GCS) shall have a common mission planning system.</p>   | <p>Since UAS air vehicles require a mission planning system, if all the mission planning systems are common in the GCS, then a single way of training for use of the mission planning interface can be utilized. This will allow for all AVO training to be consolidated into a standard AVO training pipeline.</p>  |
| <p>6. The Ground Control Station (GCS) shall enable interoperability between multiple Unmanned Aircraft Systems (UASs).</p>                               | <p>This requirement is met by function A1.4 Command and Control of Air Vehicle. This function allows for each command within the GCS system to be translated into a common control language to be sent to the air vehicle. This common language can be used to send information to all the different UAS air vehicles that understand the common language.</p> |
| <p>7. The Ground Control Station (GCS) shall enable common communications and data link management between multiple Unmanned Aircraft Systems (UASs).</p> | <p>Requirement 7 and 8 are met with function A1.7 Manage/Disseminate Data and A1.8 Perform External Comms. These functions enable physical transport layer and encoding layers that are standard between vehicles. They also allow for a standard interface that can be trained to operators in common training.</p>   |
| <p>8. The Ground Control Station (GCS) shall utilize a common data format to enable communication between multiple manned and unmanned systems.</p>       | <p>Requirement 7 and 8 are met with function A1.7 Manage/Disseminate Data and A1.8 Perform External Comms. These functions enable physical transport layer and encoding layers that are standard between vehicles. They also allow for a standard interface that can be trained to operators in common training.</p>   |

**Table 9. Linkage of JUCCS Architectural Elements to Requirements (continued)**

| <p><b>Common Architecture Requirement</b></p>  | <p><b>Linkage to JUCCS Proposed Common Architecture</b></p>   |
|--|---|
| <p>9. The Ground Control Station (GCS) systems software and architecture shall be modular and scalable.</p>  | <p>This requirement is satisfied by the separation of functions in the architecture. This will allow the architecture to be modular and scalable to different number of workstations. The software can follow this functional architecture allowing for different hardware to meet the functional requirements based on the operating environment and the need of the GCS. Each GCS can then be designed independently as long as it can run the common interface software so that common training can be realized.</p> |
| <p>10. The Ground Control Station (GCS) shall enable a common approach to simplify support and maintenance across multiple Unmanned Aircraft System (UAS) platforms.</p> | <p>Because the software can be designed to follow the common architecture, a single set of software can be used for the AVO control and interface. This means that only one set of software needs to be updated and maintained. This will simplify the support and maintenance by reducing multiple software suites that need maintenance to only a single common set of software.</p>  |
| <p>11. The Ground Control Station (GCS) shall enable a common approach to reduce the manpower requirements across multiple Unmanned Aircraft System (UAS) platforms.</p> | <p>Requirement number 11 is indirectly satisfied through this architecture by the fact that using this common architecture will reduce the manpower required. First, because of common training, fewer instructors will be needed to train new AVOs. Secondly, because AVOs can fly different types of air vehicles from the common GCS, AVOs can share responsibilities for launch and recovery of air vehicles as well as be used to help fill share AVO assignments.</p>   |
| <p>12. The Ground Control Station (GCS) shall enable a common approach to minimize Unmanned Aircraft System (UAS) basing.</p>  | <p>Requirement 12 can be indirectly met because with a common GCS and common interfaces, common simulators or training systems can be utilized on a base. This reduces the number of different kind of simulators needed. This can reduce the number of bases or the number of people needed to maintain the lower number of simulators.</p>  |

The twelve JUCCS common architecture requirements were related to elements of the JUCCS common architecture. The functional architecture is now related to the derived requirements, which in turn are related back to the original ADM requirements. The functional architecture is also traceable to elements of NAVAIR and DoD UAS requirements. The requirements and architecture are the basis of a common, modular, scalable GCS that will enable common AVO training across multiple UASs.

## **VIII. IMPROVED TRAINING POSSIBILITIES WITH JUCCS COMMON GCS ARCHITECTURE**

The current DoN UAS AVO training concept is stovepiped for each platform and is based upon the existing manned platform user community. Based upon JUCCS analysis of the BUQs, the proposed training concept is for common AVO training across UAS platforms. Benefits and challenges associated with the common AVO training proposed by the JUCCS team are explored in this section.

### **A. CURRENT NAVY UAS TRAINING PRACTICES**

#### ***1. Navy Training System Plans***

Developing stovepiped UAS training plans may be the simplest option, but it is probably not the most efficient or cost effective method to train future UAS AVOs. BAMS and Fire Scout have very different training plans and STUAS will almost certainly develop its own unique training plan when the program reaches that point.

As part of the Maritime Patrol and Reconnaissance Force (MPRF) Family of Systems (FoS), the BAMS UAS will provide a multiple-sensor, persistent maritime ISR capability, as an adjunct to the USN P-8A Poseidon Multi-mission Maritime Aircraft (MMA) weapons system. The BAMS UAS supports a wide variety of military operations. They include: maritime surveillance, communications relay, homeland defense, collection of enemy order of battle information, mine warfare, maritime interdiction, surface warfare, battle damage assessment, counter drug operations, port surveillance, battlespace management, situational awareness, and support for targeting for maritime and littoral strike [PMA-205, 2007].

The BAMS UAS, like most Group 3-5 UASs, plans to transition Naval Aviators from manned platforms to fill the AVO role. Initially, BAMS UAS operators will consist of experienced P-3C Naval Aviators who will transition directly to the BAMS UAS, and provide a pool of experienced operators. In the future, BAMS UAS operators will be

comprised of not only experienced P-8A Poseidon aircrew, but may also include initial accessions not exclusively from the MPRF community as shown in Figure 41.

As much as practical, BAMS UAS training media and delivery will emulate P-8A Poseidon and other UAS FoS approaches to ease transition training and provide training standardization. The notional BAMS UAS training system is expected to include formal schoolhouse training as well as informal training (CBT and Web-Based Training (WBT)), a Learning Management Information System, deployable training, embedded training, and training devices necessary to provide the most effective and efficient training system [PMA-205, 2007].



**Figure 41. BAMS Training Pipeline**

*The pipeline shows the training required for a BAMS AVO to be mission qualified. The training begins with new accessions, and ends with a BAMS squadron.*

Fire Scout is a USN UAS that will provide a Reconnaissance, Surveillance, and Target Acquisition (RSTA) and an Intelligence, Surveillance, and Reconnaissance (ISR) and communications relay capability in support of littoral operations. It is designed to operate as part of a Littoral Combat Ship (LCS) Aviation Mission Package (AMP) with support being focused on a distributed LCS force [PMA-205, 2008].

The Fire Scout UAS will transition MH-60 Naval Aviators to fill the AVO role. A two-man crew will operate the Fire Scout system. The crew will consist of a Naval officer AVO or MC (Mission Commander), and an enlisted Mission Payload Operator (MPO). The AVO or MC will be dual-qualified as a MH-60R/S variant helicopter pilot and as a Fire Scout operator. The training pipeline can be seen in Figure 42 on the following page.

Fire Scout training courses will be developed in accordance with Sharable Content Object Reference Model and Integrated Learning Environment requirements. The training will be provided using Interactive Media Instruction, Interactive Courseware, Computer-Aided Instruction, and the Fire Scout Mission Training Device (MTD) [PMA-205, 2008].

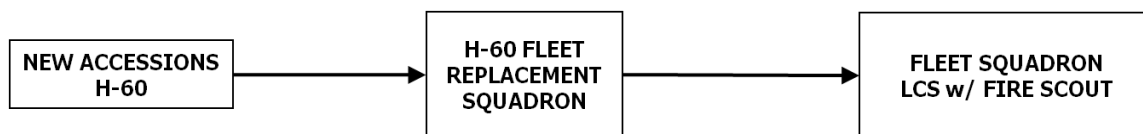

**Figure 42. Fire Scout Training Pipeline**

*The pipeline shows the training required for a Fire Scout AVO/MC to be mission qualified. The training begins with new accessions, and ends with a fleet squadron on an LCS.*

Both the Commander, Naval Surface Forces (CNSF) and Navy Expeditionary Combat Command (NECC) will operate STUAS under differing organizational and operational constructs. CNSF will operate STUAS through ship-based detachments. The detachment will bring all necessary equipment to operate STUAS from a ship that has been modified to accommodate the UAS. NECC forces within the Maritime Expeditionary Security Force (MESF) will employ STUAS in a detachment construct. The MESF plan calls for a detachment in each Maritime Expeditionary Security Squadron (MSRON). MSRON personnel will be cross-trained to operate some or all of the unmanned vehicles in the squadron, to include air, surface, or undersea vehicles.

Actual STUAS manpower and personnel requirements require further study and refinement based on training programs and operational experience. CNSF's initial manpower estimates indicate that a detachment size of five personnel is required to operate STUAS. The current MESF plan calls for a six man detachment in each of the thirteen MSRONs.

STUAS will be designed to be operated by personnel with the same or equivalent skill levels and classifications that are in the current USN active duty inventory, but this

does not imply that rated aviators are required or desired to operate the air vehicles and sensor payloads. The STUAS training system is expected to include a mix of instructor led courseware, CBT, WBT, and scenario based crew simulation training.

## ***2. Current Navy UAS Training Concepts***

BAMS fleet training will occur at one of the Continental United States (CONUS) BAMS squadrons which may be co-located with P-3C or P-8A Main Operating Bases (MOB). The BAMS UAS will be designed with an integrated full mission simulation capability, which will be capable of individual and crew training and be able to participate in strike group, fleet, and joint task force exercises [USFFC, 2009]. While this minimizes the number of unique training facilities and devices, any required modifications would be fully borne by the BAMS program.

Helicopter Sea Combat (HSC) and Helicopter Maritime Strike (HSM) squadrons support a variety of detachments including LCS aviation detachments. Since the Fire Scout AVO and MC is identified to come from the MH-60 community, the schoolhouses are conceptually identified to be co-located with fleet concentration areas of MH-60 to ease training travel and funding issues. Figure 43 illustrates the current distribution of MH-60 and Fire Scout aviation detachment locations [USFFC, 2009]. While this may make Fire Scout training more convenient for the squadron, it will require each MH-60 base to set up a full training facility for all operators and maintainers. With so many unique training facilities and devices, utilization will certainly not be optimal and any required modifications would be fully borne by the Fire Scout program.

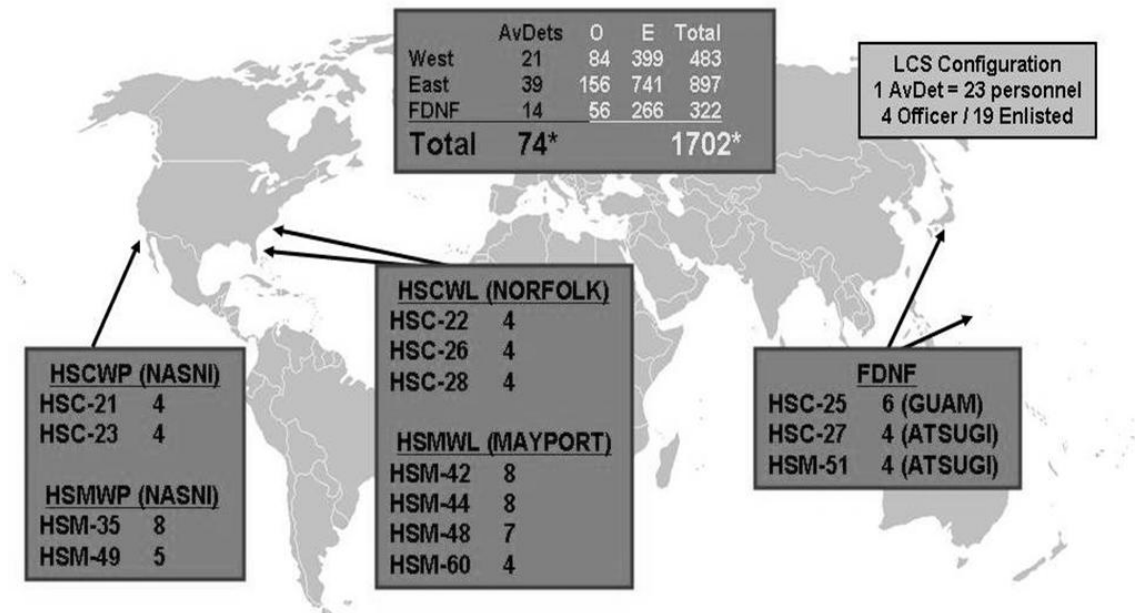

Note: \* Personnel for training and staffs not shown.

**Figure 43. MH-60 Fleet Concentration Areas**

*This illustrates worldwide concentration of MH-60/Fire Scout Aviation Detachment locations and personnel quantities. Figure from [USFFC, 2009].*

It is premature to discuss the current STUAS training pipeline since the program is still in an early development stage. Actual STUAS manpower, personnel, and training requirements require further study and refinement based upon future training programs and operational experience.

Figure 44 illustrates the large number of locations where training is currently, or planned to be performed, and the training devices for selected UAS platforms. It also highlights an inefficient USN and U.S. Marine Corp UAS training plan. These inefficiencies have caused PMA-205 to propose a *common schoolhouse* for future UAS training [PMA-205, 2009]. In addition to the common schoolhouse that PMA-205 has proposed, the JUCCS team has expanded the original PMA-205 BUQ analysis in order to determine if a common GCS architecture combined with the common schoolhouse concept can realize even greater gains for the DoD.

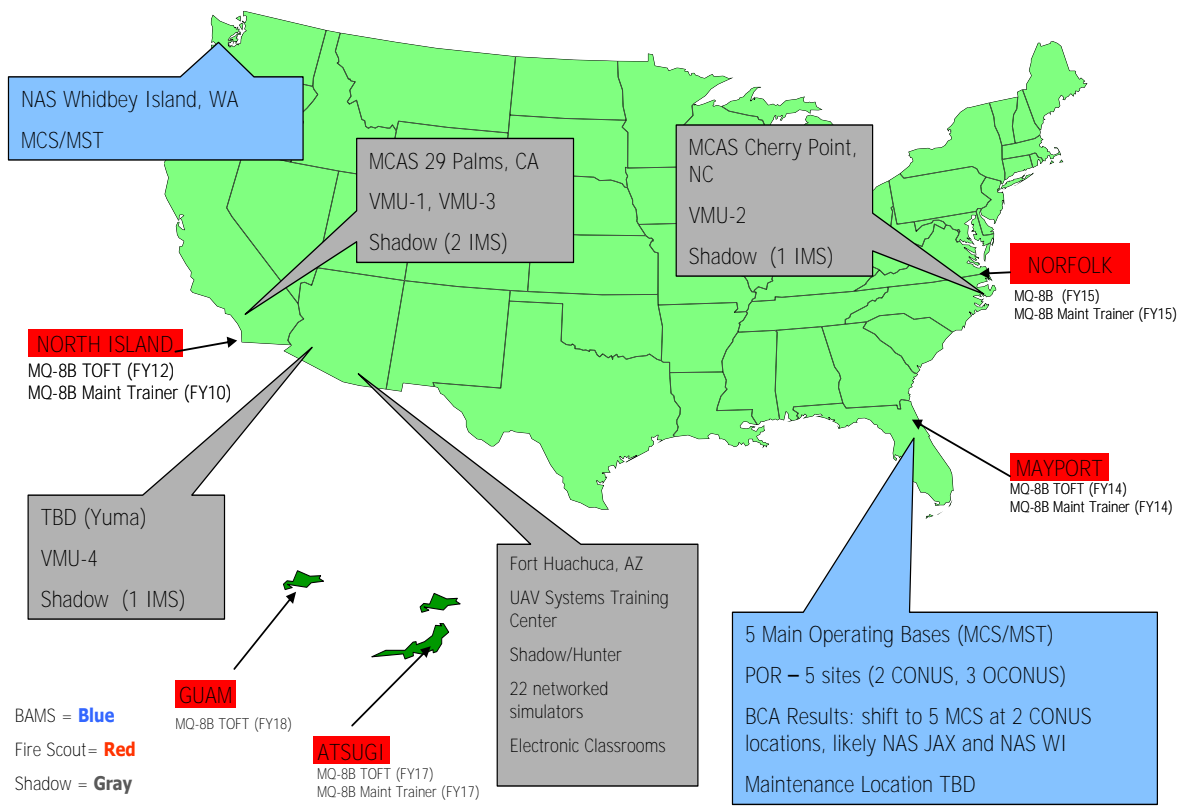

**Figure 44. Current UAS Training Locations**

*This figure illustrates training locations for selected large UASs. Note the wide distribution of training locations. Figure from [PMA-205, 2009].*

## **B. PROPOSED FUTURE NAVY UAS TRAINING PRACTICES**

PMA-205 has proposed a common schoolhouse that would be capable of common training for AVOs based upon their analysis of the BUQs. Their proposal would include a common core curriculum and platform centric curriculum. The JUCCS analysis expands upon the PMA-205 analysis and addresses the BUQs that could be achieved through the proposed architecture.

### 1. *Expanded Analysis of Basic UAS Qualifications*

The BUQ I-IV KSAs are the foundation for the design and implementation of the AVO training concept of operation. As described previously in Chapter V.C, there currently is not a single UAS training model that is employed, but rather disparate methods at decentralized training locations. A primary theory in the approach to this problem was that overhead costs incurred during AVO training would be reduced by implementing a common GCS architecture. This architectural change across Group 3-5 UASs would potentially require less infrastructure, reduced manpower requirements, and a single course of instruction for primary AVO KSAs. An analysis was conducted on the BUQ I-IV KSAs to determine if a quantifiable benefit could be realized.

The method of the analysis was to compare the BUQ I-IV KSAs against two types of GCS architectures across Group 3-5 UASs. Instructor pilots, operational pilots, and UAS engineers were asked to assess how the training of each BUQ could be conducted against two different GCS architectures. A score of *common* was to be awarded if the BUQ training was common across all the UASs. A score of *unique* was to be awarded if the BUQ training was deemed to be unique to each UAS. If one stakeholder deemed a task *unique*, while another scored it *common*, the *unique* scoring was awarded. This was done to create the most conservative comparison possible.

The first type of architecture analyzed was labeled the *As-Is* architecture. The *As-Is* represents the current approach to UAS GCS architectures where there is no consideration of commonality from one system to another. The second type of architecture analyzed was the *JUCCS Proposed Common GCS Architecture*. The *JUCCS Proposed Common* represents a common GCS architecture implementation across all Group 3-5 UASs as proposed in this project.

Table 10 represents a sample of the BUQ-III KSA analysis raw data. As an example, for the *Obtaining an IFR clearance* KSA, a score of *common* was awarded for both architectures. This is because the teaching and execution of this task is not

dependent on the interface between the AVO and the GCS. The IFR clearance is a procedural task conducted prior to flight operations and is independent of any interfaces. Conversely, the *Establishing and maintaining constant altitude, airspeed, and heading during instrument flight* KSA was scored *unique* in relation to the current HMI employed, but was scored *common* based upon the implementation of the *JUCCS Proposed Common GCS Architecture*. In this example, the instruction to teach this task would require platform specific training based upon current system design. However, the JUCCS proposed architecture with a common HMI interface would allow this task to be taught exactly the same across all candidate platforms. Table 10 shows an excerpt of the BUQ analysis, while the complete analysis of the BUQs can found in Appendix D.

**Table 10. Sample of Expanded BUQ Analysis Based on Architecture Type**

*This table is a sample of the expanded BUQ analysis performed by the JUCCS team. It shows whether specific KSAs would need to be taught in a common or unique manner based on the As-Is or JUCCS Proposed Common GCS Architecture.*

| BUQ | Category            | KSA  | Training with JUCCS Proposed Common GCS Architecture | Training with As-Is Unique GCS Architectures |
|-----|---------------------|--|--|--|
| III | Aircraft Operations | Instrument Flight  | Common   | Unique                                       |
| III | Aircraft Operations | Instrument Flight Procedures   | Common   | Unique                                       |
| III | Before Flight       | Instrument Flight Rules (IFR) mission planning   | Common   | Common                                       |
| III | Before Flight       | Obtaining an IFR clearance   | Common   | Common                                       |
| III | Before Flight       | Operation of Air Traffic Surveillance Equipment (IFF/SIF/TCAS/Sense and Avoid Sensors)         | Common   | Unique                                       |
| III | Instrument          | Partial panel instrument flight  | Common   | Unique                                       |
| III | Instrument          | Aircraft maneuvers under instrument conditions   | Common   | Unique                                       |
| III | Instrument          | Recognition of improper nose low condition   | Common   | Unique                                       |
| III | Instrument          | Course intercept   | Common   | Unique                                       |
| III | Instrument          | Rate of intercept  | Common   | Unique                                       |
| III | Instrument          | Angle of intercept   | Common   | Unique                                       |
| III | Instrument          | Recognition and recovery from unusual attitudes under instrument conditions                    | Common   | Unique                                       |
| III | Instrument          | Operation of aircraft instruments and navigation equipment                                     | Common   | Unique                                       |
| III | Instrument          | Hazardous/adverse weather conditions in flight   | Common   | Unique                                       |
| III | Instrument          | Weather phenomena which affect flight  | Common   | Unique                                       |
| III | Instrument          | Establishing and maintaining constant altitude, airspeed, and heading during instrument flight | Common   | Unique                                       |
| III | Navigation          | Unfamiliar field departure procedures  | Common   | Common                                       |
| III | Navigation          | Low level navigation   | Common   | Unique                                       |
| III | Navigation          | Unfamiliar field visual and instrument approach procedures                                     | Common   | Common                                       |

The results of the analysis for BUQs I-IV are shown in Table 11. The data shows that implementation of the *JUCCS Proposed Common GCS Architecture* will reduce the number of unique training tasks from 154 out of 213, down to 7 out of 213 total KSAs. These seven tasks are related to pre-flight, post-flight, and emergency procedures specific to the different airframes of the UASs, and will always require platform specific training. The magnitude of the reduction of unique tasks allows the consideration of a common training pipeline for AVOs, which could result in tremendous manpower, infrastructure, and cost efficiencies.

**Table 11. Reduction of Unique KSAs for the JUCCS Proposed Common versus As-Is GCS Architectures**

*This table shows a summary of the expanded BUQ analysis. The number of unique KSAs that need to be taught at each BUQ level can be drastically reduced if the proposed common GCS architecture is utilized.*

|                | <i>As-Is GCS Architecture</i> |                    | <i>JUCCS Proposed Common GCS Architecture</i> |                    | <b>Total KSAs per Architecture</b> |
|----------------|-------------------------------|--------------------|---|--------------------|------------------------------------|
|                | <b>Common KSAs</b>            | <b>Unique KSAs</b> | <b>Common KSAs</b>                            | <b>Unique KSAs</b> |                                    |
| <b>BUQ I</b>   | 36                            | 68                 | 97  | 7                  | 104                                |
| <b>BUQ II</b>  | 13                            | 18                 | 31  | 0                  | 31                                 |
| <b>BUQ III</b> | 5                             | 14                 | 19  | 0                  | 19                                 |
| <b>BUQ IV</b>  | 5                             | 54                 | 59  | 0                  | 59                                 |
| <b>TOTAL</b>   | 59                            | 154                | 206   | 7                  | 213                                |

## 2. *Proposed Common Schoolhouse Navy UAS Pipelines*

The concept of a common UAS schoolhouse has been proposed as a method to increase efficiency in the training methods of the DoD. This idea can be seen in the following statement made by the UAS Platform Wholeness CONOPS:

In order to ensure standard UAS policy and procedures and gain efficiency in training overhead a common UAS flight school or UAS school house should be established to bridge the gap between accessions programs and type/model/series (T/M/S) specific UAS training courses. [USFFC, 2009]

Driven by this statement, PMA-205 has proposed a common schoolhouse concept. Note that this concept is simply to geographically consolidate training programs, and does not rely on a common GCS concept. In order to further develop the possibilities created with a combined common schoolhouse and a common GCS, the JUCCS team expanded the BUQ analysis performed by PMA-205. This expanded analysis in the previous section shows that the number of unique KSAs for each BUQ level is dramatically reduced by implementing the *JUCCS Proposed Common GCS* architecture.

The common schoolhouse concept proposed by the PMA-205 analysis is shown in Figure 45. It shows a common, core schoolhouse where the majority of the UAS instruction is performed. It accommodates new accession operators with a comprehensive training curriculum as well as previous operators with platform specific instruction. Analysis of this concept shows that 59 of the 213 BUQ I-IV KSAs could be performed using common training with the remainder requiring platform specific training. It is important to note that this concept does not require the use of a common GCS, it simply consolidates the training locations with the current unique (*As-Is*) GCSs.

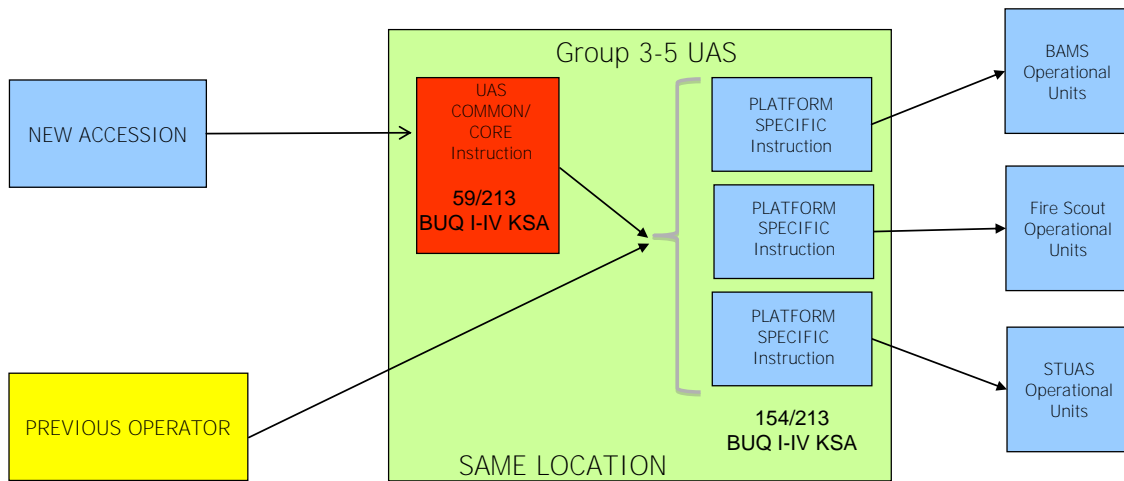

**Figure 45. PMA-205 Notional Operator Training Path**

*This diagram shows a notional training path that would result from implementing a common, core schoolhouse (but not a common GCS) concept. Note that 154 KSAs remain platform specific and need to be taught outside the common core instruction. Figure from [PMA-205, 2009].*

If the common GCS concept were included into the above analysis, improved capabilities would be realized. The result of this analysis is shown in Figure 46 on the following page. It is very similar to the PMA-205 notional operator training path, but includes more commonality based upon the proposed architecture with a common AVO interface. The JUCCS analysis shows that 206 of the 213 BUQ I-IV KSAs could be performed using common training with only seven KSAs requiring platform specific training. These seven remaining KSAs are airframe specific functions related to preflight, post-flight, and emergency procedures.

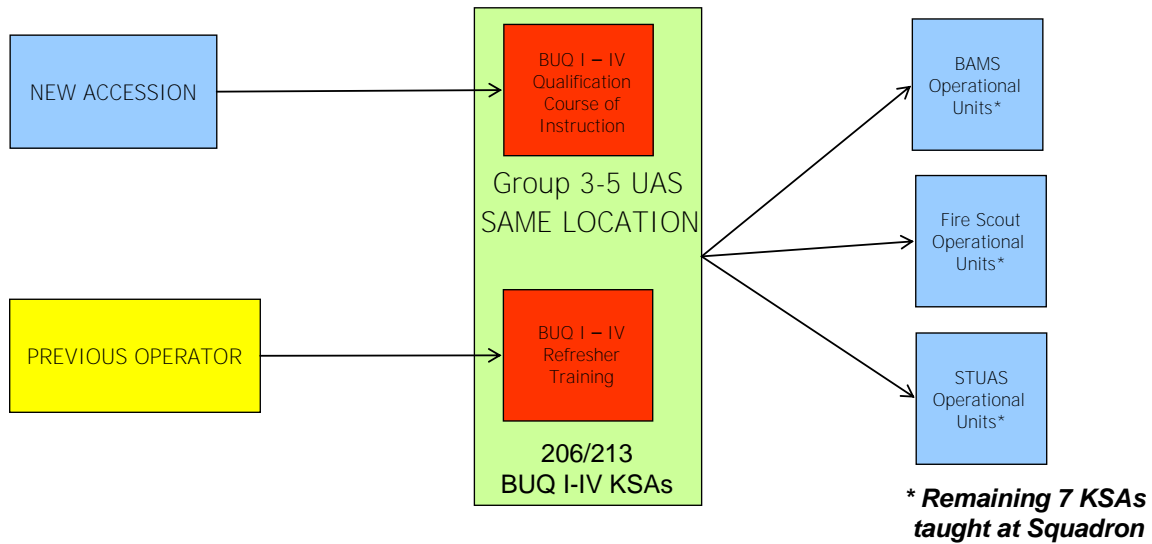

**Figure 46. JUCCS Notional Operator Training Path**

*This diagram shows a notional training path that would result from implementing a common, core schoolhouse concept with JUCCS proposed common architecture. Note that only seven KSAs need to be taught outside the common schoolhouse. These KSAs are airframe specific functions related to preflight, post-flight, and emergency procedures.*

### **3. Quantitative Benefits Analysis of JUCCS Proposed Common GCS**

To compare the benefits of implementing different approaches to GCS architectures and AVO training methods, the JUCCS team created a notional illustration to compare the three different training strategies discussed in this paper. Since STUAS is still in source selection and no training approach has been defined, Fire Scout and BAMS were the only existing UASs included in this analysis for each described approach.

The first comparison item, labeled Option 1 in Table 12, consists of the *As-Is GCS Architectures with Distributed Schoolhouses*. This concept is based upon existing BAMS [PMA-205, 2007] and Fire Scout [PMA-205, 2008] training pipelines and documented training CONOPS. The BAMS and Fire Scout GCS architectures for this concept are not common as they represent the status-quo of the respective programs.

Option 2 in Table 12 consists of the *As-Is GCS Architectures with Common Schoolhouse*. This concept is based upon the NAVAIR Training Systems (PMA-205) co-located training model discussed earlier in this paper [PMA-205, 2009]. Although this concept includes a common schoolhouse, the GCS architectures remain unique to their respective programs.

Option 3 in Table 12 consists of the *JUCCS Proposed Common GCS Architecture with Common Schoolhouse*. This concept is based upon the common GCS architecture proposed by JUCCS in this project. In addition to providing a common GCS architecture, this analysis assumes inclusion of the common schoolhouse as described by PMA-205.

To lay the foundations for the analysis and to ensure that an appropriate comparison of existing and notional pipelines was completed, the following assumptions were employed:

- Analysis is based upon yearly Operations and Sustainment (O&S) cost of the different alternatives. Historically, O&S costs are the largest component of Life Cycle Costs (LCC), and are the most relevant for this comparison. The development and Military Construction (MILCON) costs of the notional alternatives are not considered in this analysis as they are a very small percentage of the larger LCC over a 20 year operational lifespan.
- AVO throughput is assumed constant at 115 students per year. This is the sum for the current documented throughput of 75 for BAMS [PMA-205, 2007] and 40 for Fire Scout [PMA-205, 2008].

With the above assumptions made, a strategy for an appropriate analysis can be produced. This results in a set of procedures and logic that are detailed in Appendix E. The creation of this logic was based on research from many sources, which are also listed in Appendix E.

The assumptions and strategy were then incorporated into the O&S cost analysis displayed in Table 12. The O&S cost categories include: number of training sites, total number of simulators, total annual simulator O&S cost, total annual courseware

management cost, total annual infrastructure cost, total number of instructors, total annual instructor cost, total number of support and administrative personnel, and total annual support and administrative personnel cost. The table compares the cost categories for the three training options.

Option 2 is included in the analysis because it is an intermediate step between the *As-Is GCS Architectures with Distributed Schoolhouses* and the *JUCCS Proposed Common GCS Architecture with Common Schoolhouse*. This option is the PMA-205 proposed common schoolhouse solution with no common GCS architecture. It does not realize the full benefits of the *JUCCS Proposed Common GCS Architecture*. Therefore, the following discussion of the analysis will focus on comparing Option 1 to Option 3.

Several observations of the comparative analysis of Option 1 and Option 3, found in Table 12, were noted:

- A common schoolhouse concept reduces the number of training sites required from 7 to 1
- Required number of simulators decreases from 14 to 4
- Annual courseware management costs using a common architecture are reduced by taking advantage of a 96 percent common training curriculum
- Total annual infrastructure costs are reduced as the number of sites decreases
- The number of instructors, support, and administrative personnel is reduced from over 100 to 12

**Table 12. High Level Analysis of O&S Costs of Different Training Options**

*This table represents the notional O&S costs of the current and proposed training concepts. Note the reduction in O&S costs as the level of commonality increases.*

|  | Option 1                                 |  |   | Option 2  | Option 3   |
|--|--|--|---|---|--|
|  | As-Is BAMS with Distributed Schoolhouses | As-Is Fire Scout with Distributed Schoolhouses | Sum of As-Is GCS Architectures with Distributed Schoolhouses (BAMS plus Fire Scout) | As-Is GCS Architectures with Common Schoolhouse | JUCCS Proposed Common GCS Architecture with Common Schoolhouse |
| Number of training sites                               | 2  | 5  | 7   | 1   | 1  |
| Total number of simulators                             | 4  | 10   | 14  | 4   | 4  |
| Total annual simulator O&S cost                        | \$2,124,000                              | \$5,310,000                                    | \$7,434,000   | \$2,124,000                                     | \$2,124,000  |
| Total annual courseware management                     | \$381,000                                | \$381,000                                      | \$762,000   | \$571,500                                       | \$381,000  |
| Total annual infrastructure cost                       | \$231,200                                | \$578,000                                      | \$809,200   | \$231,200                                       | \$231,200  |
| Total number of instructors                            | 12                                       | 30   | 42  | 11  | 8  |
| Total annual instructor cost                           | \$2,581,608                              | \$6,454,020                                    | \$9,035,628   | \$2,366,474                                     | \$1,721,072  |
| Total number of support and administration personnel   | 18                                       | 45   | 63  | 8   | 4  |
| Total annual support and administration personnel cost | \$2,353,392                              | \$5,883,480                                    | \$8,236,872   | \$1,045,952                                     | \$522,976  |
| Total annual training O&S cost                         | \$7,671,200                              | \$18,606,500                                   | \$26,277,700  | \$6,339,126                                     | \$4,980,248  |

Several conclusions of the comparative analysis of Option 1 and Option 3 were noted. The total annual simulator O&S cost decreases by over \$5 million. Courseware management costs are reduced by half to approximately \$318,000. Total annual infrastructure costs will be reduced by 67 percent, to \$231,000. Total annual instructor cost is reduced by over \$7 million. Total annual support and administration personnel cost is reduced by 94 percent from \$8.2 million to \$0.5 million. The total annual O&S cost savings is projected to be reduced from \$26.3 million to \$5.0 million. Over a 20 year period the LCC savings would be \$426 million in current year dollars.

### **C. SUMMARY OF COMMON UAS TRAINING BENEFITS**

It is clear from the USD(AT&L) ADM that Mr. John Young believed that an opportunity existed to maximize training efficiencies by implementing a common UAS GCS architecture [USD(AT&L), 2009]. The DoN has also recognized this potential and has documented it in the *Fleet Unmanned Aircraft System Platform Wholeness Concept of Operations* [USFFC, 2009]. In this draft document, the goals of Commander, Fleet Forces Command for the DoN's UAS FoS are discussed and include:

The Navy will efficiently field a FoS of affordable UASs that are reliable and supportable in both Navy and USMC environments and interoperable with today's combat systems. The FoS approach will identify opportunities for commonality that can provide affordability, flexibility, efficiency and greater effectiveness. These opportunities include, but are not limited to: Commonality among UAS operator training standards. Common approaches to UAS manpower support and basing needs... [USFFC, 2009]

The benefits of implementing a common GCS HMI architecture directly support these goals. From an affordability perspective, the reduced need for infrastructure is the largest factor in addressing this requirement. By implementing an architecture that allows the majority of UAS training across different platforms to be common, one can also lead to the ability to train all of those operators at a single location. This leads to a reduced need for capital investments in personnel housing, training buildings, classrooms, support elements, and simulators. It also allows the efficiency desired by reducing the need for

the manpower required to run the training centers. Under the proposed approach, there is a reduced need for the number of instructors, simulator technicians, courseware managers, and support personnel. Efficiencies are also realized by increasing the utilization rate of the facilities.

The benefits of implementing a common GCS architecture still hold true even if the DoN elects to forgo a centralized training location. Some of the capital benefits discussed above certainly are reduced, however instruction could still be standardized. This leads to the requirement to develop a single core syllabus that could be centrally managed.

Another benefit of implementing the common architecture is that the time to transfer and train an AVO from one UAS to another is significantly reduced. This is an added benefit to implementing the common architecture with common AVO HMI and could have a significant impact on DoN manpower requirements regardless of whether the co-located training concept is implemented.

#### **D. CHALLENGES TO IMPLEMENTING COMMON UAS TRAINING**

Implementing a UAS training concept with co-located training brings several potential benefits as discussed above, however there are some concerns that deserve proper attention. They range from tangible concerns to cultural issues that should be considered prior to implementing this approach.

A primary concern is that there are vast differences between the larger operational concepts of the UASs that are proposed to be combined into a single training pipeline. Flying an eight hour average BAMS mission is much different than executing a two hour average Fire Scout mission. If one considers the pure difference in size between these two UASs, and the fact that one is a fixed-wing UAV while the other is a rotary-wing UAV, it becomes apparent that challenges exist. The argument is if the status-quo of separate training locations remains, the new AVOs would be trained by instructors who most likely are past operators of the same system, or at least fully immersed in the single

system, and are likely to tailor the training experience toward real world operations. In the proposed combined training concept, one could have a Fire Scout instructor teaching a BAMs operator how to conduct a landing approach. If the proposed architecture is implemented correctly, it should not matter, but it is a concern that must be addressed.

There are also benefits to conducting training at the operational bases of the UASs vice at a separately located training center. This is less tangible, but there is a benefit in having access to actual fleet AVOs during training. They provide a good source of knowledge and also are generally good critics of the quality of instruction that is being provided. They also are used to provide training to students, which may be lost if the training center was not co-located with the operational units.

Finally, if a common training center approach was implemented, the individual program offices of the UASs under development would have to implement integrated approaches toward training. This would require each PMA to relinquish total authority for training (as is implemented today) and establish a forum to employ common training. This would add requirements to the programs that would impact the budgets of the current PMAs since some of their training funding would be ported to a common training program office.

## IX. CONCLUSIONS AND RECOMMENDATIONS

### A. CONCLUSIONS

The JUCCS team conducted research to determine the plausibility of implementing commonality in UAS GCSs, and the potential benefits that could be attained by achieving such commonality. The team focused on the GCS since this is a necessary, but often overlooked portion of the overall system. Additionally, the ADM released by USD(AT&L) in 2009 directed that commonality be implemented in UAS GCSs.

To scope the problem, the JUCCS team concentrated on creation of a GCS functional architecture that enabled common AVO training. The AVO functions were chosen because they are similar from UAS to UAS, while payload functions (weapons and sensors) can vary greatly between systems. Training was selected as a focus because it was specifically cited in the ADM as a potential benefit from GCS commonality. The scoped problem was then used to answer the research questions posed by the team at the beginning of the project:

*Research Question 1.* What is meant by common and what is this project's interpretation of common?

At a basic level, common means that some aspect of a system is shared with another system. This can include hardware, software, or data link languages in a UAS. This project interprets common to mean that two or more UASs share an aspect that will add functional, operational, or logistical advantage to the systems.

*Research Question 2.* Is there a link between commonality and interoperability?

The analysis showed that commonality and interoperability, while sometimes used interchangeably, are two different concepts. Discussions included the notion that commonality and interoperability can be achieved independently from each other. It was shown that commonality is possible without interoperability, and interoperability is possible without commonality. Achieving the goals stated in the 2009 ADM require

some level of both commonality and interoperability for UASs. In general, some amount of commonality is typically required to realize a level of interoperability between systems. *JUCCS Proposed Common GCS Architecture* facilitates commonality for the GCS and enables interoperability between UAS platforms.

*Research Question 3.* Is it possible to achieve some level of commonality for UAS GCSs, and if so, what requirements are necessary?

The analysis completed in this project shows that it is possible to achieve some level of commonality for UAS GCSs. While this has not happened frequently in the past, it is possible for future acquisitions.

In order to facilitate common AVO training to the maximum extent, the JUCCS analysis showed that a common HMI for AVO functions is necessary. The common HMI concept requires a directed type interface where the flight parameters (airspeed, altitude, latitude, longitude, etc) are input, as opposed to a controlled type interface where piloting devices (flight sticks, throttle, rudder, etc) are utilized. This type of HMI commonality does not exist for current systems.

Analysis of BUQs showed that there were no common standards for AVO training and qualifications. Additionally, requirements for UAS commonality were not present in any DoN programs examined. The following twelve system requirements were determined to be necessary to achieve common AVO training and the other functions required by the DoN UAS community:

*Requirement 1.* The Ground Control Station (GCS) shall enable Air Vehicle Operator (AVO) training commonality across multiple UAS platforms.

*Requirement 2.* The Ground Control Station (GCS) shall have a common Human-Machine Interface (HMI) for Air Vehicle Operator (AVO) functions.

*Requirement 3.* The Ground Control Station (GCS) shall allow for directed vice controlled air vehicle operation.

*Requirement 4.* The Ground Control Station (GCS) shall allow for separate Human-Machine Interfaces (HMI) for payload and air vehicle control.

*Requirement 5.* The Ground Control Station (GCS) shall have a common mission planning system.

*Requirement 6.* The Ground Control Station (GCS) shall enable interoperability between multiple Unmanned Air Systems (UASs).

*Requirement 7.* The Ground Control Station (GCS) shall enable common communications and data link management between multiple Unmanned Air Systems (UASs).

*Requirement 8.* The Ground Control Station (GCS) shall utilize a common data format to enable communication between multiple manned and unmanned systems.

*Requirement 9.* The Ground Control Station (GCS) systems software and architecture shall be modular and scalable.

*Requirement 10.* The Ground Control Station (GCS) shall enable a common approach to simplify support and maintenance across multiple Unmanned Air System (UAS) platforms.

*Requirement 11.* The Ground Control Station (GCS) shall enable a common approach to reduce the manpower requirements across multiple Unmanned Air System (UAS) platforms.

*Requirement 12.* The Ground Control Station (GCS) shall enable a common approach to minimize Unmanned Air System (UAS) basing.

In order to be effective, these requirements would need to be mandated for future acquisition programs. This list of requirements alone is not enough to create an actual common system, and leads to the next research question:

*Research Question 4.* To meet these requirements, what architectural characteristics need to be developed?

From these requirements the *JUCCS Proposed Common GCS Architecture* was developed. This architecture fulfills the commonality desired in the ADM. The primary characteristic modeled was an independent HMI function for interacting with the AVO. The functional architecture was developed to be both modular and scalable. The air vehicle control function was designed to be a single interoperable format that would be used by all future UAVs to communicate with the common GCS.

*Research Question 5.* What are some of the benefits and challenges of achieving UAS GCS commonality?

Using the *JUCCS Proposed Common GCS Architecture*, an expanded analysis was performed against the BUQs. It was shown that implementing the JUCCS architecture would allow for common AVO training in all areas except those that are related to specific UAV airframes (pre-flight, post-flight, and emergency procedures). A brief analysis was performed to show an example of monetary savings that could be achieved by using the JUCCS architecture through reduction in instructors, training devices, and system and software maintenance. The analysis showed a potential cost savings of over \$400 million in O&S costs for training aspects of the GCS common architecture over a 20 year span. This quantification did not include potential benefits other than those found in training and additional benefits can be expected when other logistical elements are analyzed.

Additionally, some of the challenges related to a common GCS architecture were explored. These challenges relate to the differing missions of the UASs affecting the common schoolhouse concept. UAS program offices would also lose some of the autonomy they currently have due to the need for a separate common GCS program office.

In summary, the JUCCS project has developed a set of key requirements necessary for the creation of a common GCS architecture. These requirements were used to create the innovative *JUCCS Proposed Common GCS Architecture* with a common AVO HMI. This approach facilitates common training for UAS AVOs. In addition to increasing operational capability, the common GCS architecture also facilitates interoperability. The common GCS architecture provides additional benefits of reducing training O&S costs and ensuring consistent UAS AVO training.

## **B. RECOMMENDATIONS**

To enable the common GCS architecture, it is recommended that changes be made to the existing NAVAIR acquisition process. Currently, entire systems are

procured through a single program office. For traditional aircraft and weapons with a single main airframe this works well. In the world of UASs, there are two major system components, the UAV and the GCS. Presently, both the UAV and GCS are procured together through one program office. This is the traditional model for acquisition at NAVAIR.

Some activities of hardware or software that are shared between programs, such as the Joint Mission Planning System (JMPS), are implemented by a separate program office that is responsible for the maintenance, support, and configuration management of the system. The JMPS program office has control over the software, can set some specifications on the hardware that is needed to run it, and provides all the interface documents to the individual programs that are going to use the software.

The method recommended by the JUCCS team to implement a common GCS is to establish a separate program office for the common GCS. To allow the common GCS to remain modular and scalable, the common GCS program office would control the architecture and software of the GCS. The AVO software could be kept standardized by utilizing a common HMI module specifically for AVO functions. This would enable common AVO training between multiple platforms.

Payload control software could also be kept as separate modules and libraries of specific software subroutines for controlling various types of payloads. If a program needed to develop a new type of interface, both for data transfer and HMI, then those new subroutines could be added to the common payload library for use by new systems or for upgrading older ones.

Each program office for a new UAS would be responsible for the new UAV and its capabilities. The UAS program office would also be responsible for the physical hardware and layout of the GCS. This would allow the programs to scale the GCS hardware to the system requirements. Some large UASs may require a larger GCS crew, such as the six planned for BAMS. Other UASs may require two or fewer operators.

The UAS program office could scale the operator stations to those necessary for the system. This ability would allow the use of different hardware based on the operating environment of the GCS. A ship based GCS may require hardware (antennae, computers, etc) that are hardened against water and salt. An aircraft based GCS may need a trackball that can remain stationary at a workstation while the aircraft maneuvers.

The individual UAS program offices would coordinate with the common GCS program office to effectively transfer the government furnished software and work with the UAV prime contractor to make the necessary hardware and software changes to meet the common GCS levels of commonality and interoperability. This would be analogous to the way the JMPS program office currently conducts business with other entities within NAVAIR.

Once the common GCS program office is operational, it would be necessary for NAVAIR to mandate a requirement that the common GCS architecture be used by all new DoN UAS programs. This mandatory requirement would ensure the level of commonality needed to implement and sustain common AVO training.

### **C. AREAS FOR FURTHER STUDY**

The JUCCS team limited the scope of this research to the very specific area of commonality in the GCS and how it would relate to AVO training. From the generated architecture and the results of the training analysis, other areas of study can be recommended for follow on research:

1. A cost benefit analysis of the effect the commonality and interoperability the JUCCS architecture would have on the ten elements of logistics is recommended. This research could further examine the cost and time savings realization on manpower requirements, basing, personnel assignments and training, etc. as discussed in Chapter III.D.
2. An analysis and design of a standardized common AVO HMI is recommended. While this report showed the benefit of using a common AVO HMI, actual functions and how

they would be designed for operator interaction needs to be defined. This would include the software functional architecture and the actual physical architecture for the software user interface as well as the relative layout of the displays and audio and tactile information for the AVO. This effort would need to include the requirements of displays and their relative positions to each other. Implementation of input devices would need to be discussed as well as other operator interaction requirements.

3. Design of an interoperable air vehicle command and control module used by the common GCS for sending AVO commands is recommended. This effort would require a gap analysis to look at STANAG 4586 and compare it to the needs of current DoN programs. If STANAG 4586 were found to be insufficient to meet the AVO functions of the common GCS, a new standard for DoN UASs would need to be developed.

4. Further analysis of the internal and external data link and communications for the JUCCS functional architecture is recommended. This would lead to an expansion of the JUCCS architecture to lower levels in the internal and external communications functions. These new functions could then be analyzed for design of the physical architecture. This design would need to examine both LOS and OTH communications. Existing systems would need to be explored to see if they could be used to facilitate the functions of the architecture.

5. Investigation of common payload HMI functions is recommended. The payload HMI and functionality was specifically excluded from the JUCCS architecture. Because the payloads can vary so greatly from one UAV to another, a common approach to payloads was not explored. Further research could be conducted on possible functional modules for both sensors and payloads. This research could be the basis for a payload control and HMI library in a common GCS program.

THIS PAGE INTENTIONALLY LEFT BLANK

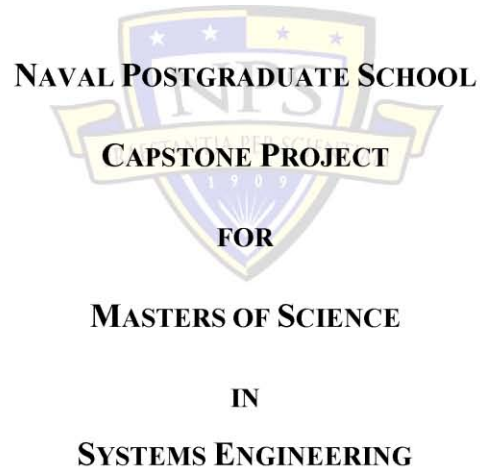

# APPENDIX A: PROJECT MANAGEMENT PLAN



## **Joint Unmanned Aircraft Systems Common Control Station (JUCCS)**

PROJECT MANAGEMENT PLAN

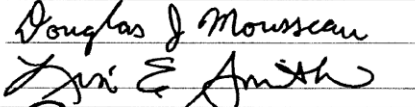
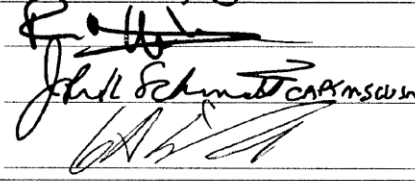
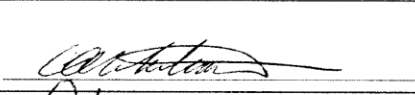
**NAVAIR COHORT #1**  
**MSSE Cohort 311-0832**

|                     |                               |  |
|---------------------|-------------------------------|--|
| <i>SUBMITTED BY</i> | JUCCS Team<br>Representatives |  |
| <i>REVIEWED BY</i>  | Project Advisors              |  |
| <i>REVIEWED BY</i>  | MSSE Academic<br>Associate    |  |
| <i>APPROVED BY</i>  | SE Department Chair           |  |

## Revision History

| <i>Revision</i> | <i>Description of Changes</i> | <i>Date</i>  |
|-----------------|-------------------------------|--------------|
| 0               | Original Document             | 23 July 2009 |
| 1               | Initial Release Document      | 10 Aug 2009  |
| 2               | Final Release                 | 25 Aug 2009  |
| 3               | Final Release – Updated       | 3 Sep 2009   |
| 4               | Update 1                      | 7 Feb 2010   |
|                 |                               |              |
|                 |                               |              |
|                 |                               |              |
|                 |                               |              |

**TABLE OF CONTENTS**

1.0 Introduction .....1

    1.1 Project Description.....1

    1.2 Problem Statement .....2

    1.3 Project Proposal .....3

    1.4 Organization .....3

        1.4.1 Roles & Responsibilities .....4

        1.4.2 Roles and Responsibilities Defined .....5

        1.4.3 JUCCS Team Member Assignments and Responsibilities .....6

        1.4.4 Project Advisors.....7

        1.4.5 Stakeholders .....7

    1.5 Approach for PMP Updates.....10

    1.6 Configuration Management.....11

    1.7 Interim Project Reviews (IPR).....11

    1.8 Final Report and Brief.....11

2.0 Systems Engineering Approach .....14

    2.1 Overview .....14

    2.2 Information Gathering and Problem Definition .....17

    2.3 Problem Scoping.....17

    2.4 Concept Development.....17

    2.5 Engineering Development.....18

    2.6 Design Recommendations / Conclusions.....18

    2.7 Tools.....18

    2.8 Risk Management .....19

|       |                                 |    |
|-------|---------------------------------|----|
| 2.8.1 | Risks .....                     | 20 |
| 2.8.2 | Issues .....                    | 20 |
| 3.0   | Deliverables and Schedule ..... | 21 |
| 3.1   | IPRs and Deliverables .....     | 21 |
| 3.2   | Schedule .....                  | 21 |
| 4.0   | Acronyms .....                  | 24 |
| 5.0   | Works Cited .....               | 26 |

## LIST OF FIGURES

|  |    |
|--|----|
| Figure 1-1. JUCCS Team Organization .....  | 3  |
| Figure 1-2. Individual Assignments to the IPT Groups .....                       | 7  |
| Figure 2-1. Generic Systems Engineering Process (Kossiakoff & Sweet, 2003).....  | 15 |
| Figure 2-2. Tailored Systems Engineering Process for Team JUCCS .....            | 16 |
| Figure 2-3. Sample DoD Risk Matrix Format, based on (NAVAIR, January 2008) ..... | 19 |
| Figure 2-4. JUCCS Project Current Risks.....                                     | 20 |
| Figure 3-1. JUCCS Project Plan .....   | 23 |

## LIST OF TABLES

|   |    |
|---|----|
| Table 1-1. Student Knowledge Assessment Tool..... | 5  |
| Table 3-1. List of IPRs and Deliverables.....     | 22 |

## 1.0 INTRODUCTION

This is the Capstone Project Management Plan (PMP) for the Naval Air Systems Command (NAVAIR) Cohort #1, hereto after referred to as the Joint Unmanned Aircraft (or Air) Systems (UASs) Common Control Station (JUCCS) team. As part of the Naval Postgraduate School (NPS) Master of Science in Systems Engineering (MSSE) Capstone Project, the JUCCS team will investigate and evaluate the potential for commonality among UAS Ground Control Stations (GCSs) as outlined in this document and per the memorandum delivered to the cohort (NPS, May 2009).

### 1.1 Project Description

The current generation of unmanned aircraft systems (UASs) have been in development for defense applications since the 1980's (GAO, April 2006). Commonalities among subsystems, payloads, and ground control stations have not yet been attained (GAO, July 2009). This lack of commonality is seen not only between service-specific UASs, but also between Department of the Navy (DON) acquired UASs. DON UASs are currently developed with unique GCSs. The primary focus of each of these GCSs has been to assist in the flight operational capabilities of the air vehicle or the control and operation of the onboard sensor suite. Minimal attention has been paid to the design of the ground station other than what has been required to meet basic air vehicle functionality. Additionally, the design requirements for the GCSs have been determined predominately by each air vehicle vendor. Therefore, as more systems are being acquired by the DON, the population and variety of GCS equipment has begun to proliferate with little regard for commonality in hardware, software, training and logistics.

The Under Secretary of Defense for Acquisition, Technology and Logistics (USD (AT&L)), Mr. John J. Young, Jr., recognized this critical and timely issue during a program review in late 2008. In a 11 Feb 2009 Acquisition Decision Memorandum (ADM) to the Secretaries of the Army, Navy and Air Force, Young states: "the acquisition team has the opportunity to do something truly joint and powerful by adopting a common GCS architecture that is open and thus will allow for rapid addition of modular functionality" (USD(AT&L),

February 2009). He continues in the same ADM to direct steps to be taken, including “initiate a joint effort to develop and demonstrate a common, open and scalable UAS architecture...”

In July 2009 the U.S. Government Accountability Office (GAO) released a written report to the Subcommittee on Air and Land Forces, House Armed Services Committee that provides more insight into Mr. Young’s direction. The GAO states that “taking an open systems approach and designing systems with common subsystems and components can reduce both production and life cycle costs as well as improve interoperability among systems...Unmanned aircraft systems can potentially achieve commonality in design and development...as well as commonality in production facilities, tooling, and personnel” (GAO, July 2009). The GAO concluded that “DoD officials have not quantified the potential costs or benefits of pursuing various alternatives, including systems with commonalities” (GAO, July 2009).

To begin filling this void where no quantifiable data exists, this project proposes to identify areas of UAS GCS commonality as directed by the USD (AT&L) ADM. This project will focus its investigation on the GCSs that are currently in operation, development, and planning stages by the DON as described in the Unmanned Systems Integrated Roadmap (USD(AT&L), April 2009). The JUCCS team will define and evaluate modular and open architecture opportunities of common GCS hardware, software, and logistical elements. A systems engineering (SE) approach, as described in Section 2.0, will be utilized.

## **1.2 Problem Statement**

The lack of: 1) common standards, 2) design for modularity, and 3) open system specifications has resulted in the problem of unique GCSs for each DON UAS, increasing acquisition expenses, training requirements, and logistics footprints. The Department of Defense (DoD) has been directed to develop a plan to add commonality to UAS programs since the DoD cannot continue to develop, sustain, and operate UASs founded on stand-alone, propriety architectures. In the absence of any quantifiable evidence, Mr. Young has stated, and the GAO has concluded, that a common GCS for UASs may yield benefits to the common logistics elements of training and maintenance.

### 1.3 Project Proposal

This capstone project will analyze the command and control (C2) architecture for current and new acquisition of Groups 2 through 5 DON UASs (non-man-portable) in order to optimize the benefits of GCS commonality for training, manpower, basing and logistics support. The goal of this analysis is to inform decision makers on the benefits and risks associated with designing commonality into GCSs. In support of this goal interviews will be conducted with subject matter experts and case studies will be examined.

The expectation of this research is to identify potential areas of commonality that future GCS acquisitions can leverage for more effective acquisition programs. The systems engineering architecture and framework for common GCSs may yield potential benefits including common logistics elements of training, maintenance and sustainment.

### 1.4 Organization

The JUCCS team organization is provided in Figure 1-1. The areas of responsibilities within the team organization, defined as Integrated Product Teams (IPTs), were chosen to optimize the success of the capstone project.

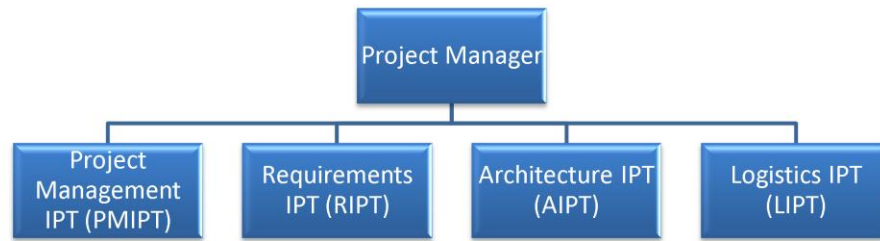

**Figure 1-1. JUCCS Team Organization**

*This chart shows the JUCCS team organization structure. The Project Manager is shown at the top of the hierarchy with the individual IPTs reporting upward.*

#### *1.4.1 Roles & Responsibilities*

The JUCCS team consists of 12 interdisciplinary team members located in the vicinity of Naval Air Station Patuxent River, Maryland. All team members have acquisition experience from working within the competencies or Program Offices of NAVAIR.

Assigning the Project Manager role was based on three key elements: 1) UAS knowledge, 2) leadership ability, and 3) understanding of systems engineering (SE) principles. Once this critical position was selected and approved by the JUCCS team members, the JUCCS IPTs were assigned to individual team members.

A student knowledge assessment tool was used to assist with the roles and responsibilities within the IPTs. This tool allowed each team member to assess his/her strengths and weaknesses in both SE topics (e.g., human factors, cost analysis, etc.) and software program tools (e.g., CORE, ExtendSim, etc.) and was used to aid in placing each member in an appropriate IPT. An example of the student knowledge assessment tool can be seen in Table 1-1.

**Table 1-1. Student Knowledge Assessment Tool**

The student knowledge assessment tool was used to evaluate the strengths and weaknesses of the project members. This evaluation was then used by the group to properly place individuals within the IPT structure.

| Name | Topic                | Knowledge Level |            |   |   |   |   |   |   |   |   |    |   |  |
|------|----------------------|-----------------|------------|---|---|---|---|---|---|---|---|----|---|--|
|      |                      | 0               | 1          | 2 | 3 | 4 | 5 | 6 | 7 | 8 | 9 | 10 |   |  |
| 6    | UAV Gen Knowledge    |                 |            |   |   | X |   |   |   |   |   |    |   |  |
|      | C2 Console Knowledge |                 |            | X |   |   |   |   |   |   |   |    |   |  |
|      | Architecting         |                 |            |   |   |   |   |   |   |   | X |    |   |  |
|      | Cost Analysis        |                 |            |   |   |   |   |   |   |   | X |    |   |  |
|      | Research             |                 |            |   |   |   | X |   |   |   |   |    |   |  |
|      | Human Factors        |                 |            |   |   |   |   | X |   |   |   |    |   |  |
|      | R&M                  |                 |            |   |   | X |   |   |   |   |   |    |   |  |
|      | M&S                  |                 |            |   |   |   |   |   |   |   |   |    | X |  |
|      | Program Mgmt         |                 |            |   |   |   |   |   |   |   |   |    | X |  |
|      | Paper Editing        |                 |            |   |   |   |   |   |   |   | X |    |   |  |
|      | Requirements Develop |                 |            |   |   |   |   | X |   |   |   |    |   |  |
|      | DOTMLPF              |                 |            |   |   |   |   | X |   |   |   |    |   |  |
|      | Core                 |                 |            |   |   |   |   |   |   | X |   |    |   |  |
|      | ExtendSim            |                 |            |   |   |   |   |   |   | X |   |    |   |  |
|      | Blackboard           |                 |            |   |   |   |   |   |   |   |   |    | X |  |
|      | MS Excel             |                 |            |   |   |   |   |   |   |   | X |    |   |  |
|      | MS Word              |                 |            |   |   |   |   |   |   | X |   |    |   |  |
|      | MS Project           |                 |            |   |   |   |   |   |   |   |   |    | X |  |
|      | <b>Student Avg:</b>  |                 | <b>6.8</b> |   |   |   |   |   |   |   |   |    |   |  |

Note: Be honest in describing your strengths and weaknesses. For Example: If you have never used CORE or EXTENDSIM, then you should rank them in the 0-2 ranking. If you did all of the ExtendSim projects by yourself and feel that you are awesome doing that, then you should be in the 9-10 category.

**1.4.2 Roles and Responsibilities Defined**

Project Manager (PM): Responsible for managing all IPTs within the organizational structure of the capstone project. He/She will make executive decisions at times when matters are not agreed upon by the team members. He/She will be the primary point of contact between the project advisors, external stakeholders, and the capstone team members.

Requirements IPT (RIPT): Responsible for compiling requirements documents from existing Navy UAS programs in support of a requirements and constraint analysis. The analysis from the RIPT will aid the Architecture IPT with direction for the common architecture.

Architecture IPT (AIPT): Responsible for defining and implementing the JUCCS architecture by using the DoD Architecture Framework (DoDAF) version 1.5 as the primary reference. Tasking includes creation of an upper level Concept of Operations (CONOPS), functional decomposition and proposed functional architecture. The architecture team members will use the CORE software package as their primary tool.

Project Management IPT (PMIPT): Responsible to assist the PM in all project management efforts to include schedule generation and compilation of document deliverables and includes the following roles:

- Editors (EDR): Responsible for the proper editing of all document deliverables. They are responsible for every document deliverable's configuration control and administration.
- BlackBoard Administrators (BBAdm): Responsible for the administration of the capstone project's BlackBoard website. They will manage the website in an efficient, presentable, and organized manner to allow for clear communications and data exchange among team members.
- Project Scheduler (PS): Responsible for maintaining the capstone project's Master Project Schedule. He/She will also maintain a master schedule that consists of each team member's work schedule and time away from the office.

Logistics IPT (LIPT): Responsible for assessing potential benefits of implementing the common architecture designed by the Architecture IPT. The assessment will include benefits that can be expected from a logistical (training) standpoint. Tasking includes development of appropriate metrics, meetings with stakeholders and performing an Analysis of Alternatives (AoA)

#### ***1.4.3 JUCCS Team Member Assignments and Responsibilities***

The initial placement of each team member can be seen in Figure 1-2. The roles and responsibilities are subject to change as the project progresses.

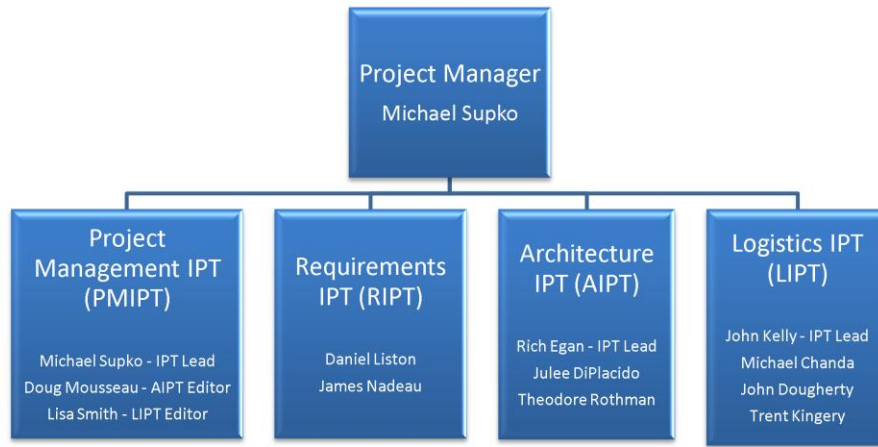

**Figure 1-2. Individual Assignments to the IPT Groups**

*This figure shows the assignments of all individuals within the IPT structure chosen for the JUCCS project.*

**1.4.4 Project Advisors**

The JUCCS team advisors are Dr. Richard Millar, Mr. Gregory Miller, and Captain John Schmidt. Dr. Millar and Mr. Miller are NPS faculty members in the Department of Systems Engineering. Captain Schmidt is a NPS adjunct faculty member and is assigned to the Naval Air Systems Command (NAVAIR).

**1.4.5 Stakeholders**

The following organizations have some part in the UAS development process or are involved in the design, management, production, and maintenance of the systems. They are grouped into three categories: resource sponsor, acquisition community, and user community.

Stakeholders will be contacted for information during the development of the JUCCS project. The stakeholders will be asked to give briefs, share documents, and be interviewed in order to retrieve relative information for this study. This information will be

reviewed and incorporated in the analysis of the common GCS problem. Since there is currently no overriding regulations on commonality between GCSs, the JUCCS team will identify any misalignments between the various stakeholders.

Additional stakeholders may be identified by the JUCCS team as research progresses. These additional stakeholders will be added as necessary and the JUCCS team will address their concerns, as applicable.

**1.4.5.1 Resource Sponsor**

- Office of the Chief of Naval Operations, Air Warfare Division (OPNAV N88 or N88): OPNAV N88 responsibility is to validate and resource Research, Development, Test and Evaluation (RDT&E) and aircraft procurement for the USN.

**1.4.5.2 Acquisition Community (NAVAIR, August 2009):**

- Program Executive Office Unmanned Aircraft and Weapons (PEO (U&W)): The PEO (U&W) will expeditiously develop, acquire, and support quality air to ground strike weapons, unmanned aerial vehicles, and target systems with which the operating forces, in support of our Unified Commanders and allies, can train, fight, and win.
- PEO U&W Common System Integration Team (PEO (U&W) CSI): Organization stood up by PEO (U&W) to facilitate a larger integration of common systems within USN UAS programs.
- Naval Air Systems Command (NAVAIR): NAVAIR provides unique engineering, development, testing, evaluation, in-service support, and program management capabilities to deliver airborne weapons systems that are technologically superior and readily available. Using a full-spectrum approach, the command delivers optimal capability and reliability for the Sailor and the Marine. All of the UAS program offices are sub-groups of NAVAIR.

- Naval Air Warfare Center Aircraft Division (NAWCAD): NAWCAD provides engineering and business development of new aircraft systems in support of NAVAIR.
- PMA-262: The Persistent Maritime Unmanned Aircraft Systems Program Office (PMA-262) was established to manage the development, production, fielding, and sustainment of all persistent maritime unmanned aircraft systems. Programs that currently fall under the cognizance of PMA-262 include the Broad Area Maritime Surveillance (BAMS) UAS and the BAMS Demonstrator programs.
- PMA-263: The Small Tactical Unmanned Air System Program Office (PMA-263) is responsible for the management of developing, producing, and sustaining small UASs. The office currently also runs the Scan Eagle Intelligence, Surveillance, and Reconnaissance (ISR) services contract.
- PMA-266: PMA-266 is the Program Office for Multi-Mission Tactical UAS. The program office has cognizance over the Vertical Takeoff and Land Tactical Unmanned Aerial Vehicle (VTUAV), commonly known as Fire Scout. The program office is also responsible for the emerging area of Air Launched UASs, poised to transition this developmental capability to a production fleet capability.
- PMA-268: Navy Unmanned Combat Air System Program Office (PMA-268) is currently managing the demonstration program for an Unmanned Combat Air System (UCAS). The program's goal is to demonstrate the feasibility of aircraft carrier operations for an unmanned system.
- USN Operational Test and Evaluation Force (OPTEVFOR): As the sole independent agent for Operational Test and Evaluation (OT&E) in the Navy's acquisition process, OPTEVFOR conducts OT&E in a realistic operational environment. OPTEVFOR also

advises the Chief of Naval Operations (CNO) on the operational effectiveness and suitability of new and improved war fighting systems and capabilities, tactics, and procedures.

- Naval Test Wing Atlantic: Located at Patuxent River Naval Air Station, the air wing is comprised of various test squadrons responsible for developmental testing of unmanned systems.
- Production Contractors: Various companies that design and build UASs for the Navy. A common GCS will change the way companies conduct business.
- U.S. Air Force: The largest Department of Defense (DoD) group currently developing and fielding UASs. The Air Force is currently looking at ways of increasing commonality between systems. The Air Force has a parallel structure for development and fielding of UASs.

#### **1.4.5.3 User Community**

- Combatant Commander (COCOM): The field users of the UASs.

### **1.5 Approach for PMP Updates**

The JUCCS PMP is a living document that provides the framework for project execution and completion. As such, it will be updated throughout the project lifecycle as necessary. At a minimum, it will be updated once prior to the final brief. Minor updates to the PMP such as schedule and organizational changes will be coordinated through the JUCCS project advisors for approval. Major changes to the PMP, to include major scope changes to the project, or any change deemed appropriate by the project advisors, will require the approval of the Chair of the NPS Systems Engineering Department. Once changes are approved at the appropriate level, the PMP will be updated, and a record of the change will be documented at the beginning of the PMP.

## **1.6 Configuration Management**

The deliverables created by the JUCCS team are planned to be in the form of documents, presentations, architectures and analyses. The Editors will maintain a copy of all deliverables and deliverable revisions in a chronological archive. The JUCCS team will revise each of the deliverables as necessary prior to being finalized for submittal. The JUCCS team edits will be tracked utilizing a system of incremental alphabetical revisions (e.g., PMP Rev A to PMP Rev B). Once a deliverable is ready for submittal it will be published utilizing numeric revision (e.g., PMP Rev 1).

## **1.7 Interim Project Reviews (IPR)**

The JUCCS team will employ interim project reviews (IPRs) to ensure accuracy, validity, and appropriateness of the project objectives and requirements. Capstone work products will be reviewed by the JUCCS team, its advisors, and project stakeholders to ensure all parties understand the problem, the approach and the proposed solution. Two IPRs will be conducted during the project's timeline. The IPRs will assess the validity of the problem identification and analysis. They will also assess the technical quality and depth of proposed solution. During the IPRs, the project team will test assumptions, review stakeholder inputs and confirm with project advisors that adequate SE rigor has been applied to the defined problem.

## **1.8 Final Report and Brief**

The final report will provide details of the SE process applied to the problem statement defined by the JUCCS team. It will include conclusions and recommendations on potential areas of commonality for GCSs. A pre-brief of the final presentation will be given to the academic advisors followed by the final brief to NPS and the stakeholders. The final brief will provide the executive summary to include conclusions and recommendations. The planned outline of the final report is shown below:

|  |           |
|--|-----------|
| <b>I. INTRODUCTION AND BACKGROUND</b> .....  | <b>1</b>  |
| A. COMPONENTS OF A UAS .....   | 2         |
| B. COMMONALITY AND INTEROPERABILITY.....   | 5         |
| C. <u>EXAMPLE COMMONALITY PROBLEM PREDATOR AND SKY WARRIOR</u> .....   | 6         |
| D. <u>RESEARCH QUESTIONS</u> .....   | 7         |
| E. PROJECT GOALS AND DELIVERABLES.....   | 8         |
| F. SYSTEMS ENGINEERING PROCESS .....   | 9         |
| 1. <u>Information Gathering and Problem Definition</u> .....   | 11        |
| 2. <u>Problem Scoping</u> .....  | 11        |
| 3. <u>Concept Development</u> .....  | 11        |
| 4. <u>Engineering Development</u> .....  | 11        |
| 5. <u>Design Recommendations and Conclusions</u> .....   | 12        |
| G. <u>INTEGRATED PRODUCT TEAMS AND TEAM MEMBER ROLES</u> .....   | 12        |
| <b>II. UAS AND GCS BACKGROUND INFORMATION</b> .....  | <b>15</b> |
| A. UNMANNED SYSTEMS INTEGRATED ROADMAP (FY2009-2034).....  | 15        |
| B. <u>GOVERNMENT ACCOUNTABILITY OFFICE REPORTS 06-49, 06-610T AND 09-520 ON UNMANNED AIRCRAFT SYSTEMS</u> .....          | 16        |
| C. STANAG 4586 - STANDARD INTERFACES OF UAV CONTROL SYSTEM FOR NATO UAV INTEROPERABILITY .....                           | 19        |
| D. <u>USD(AT&amp;L) ADM2009 - UNMANNED AIRCRAFT SYSTEMS GROUND CONTROL STATION ACQUISITION DECISION MEMORANDUM</u> ..... | 25        |
| E. <u>VARIATIONS OF GROUND CONTROL STATIONS</u> .....  | 28        |
| F. SUMMARY OF BACKGROUND INFORMATION.....  | 33        |
| <b>III. PROBLEM DEFINITION</b> .....   | <b>35</b> |
| A. <u>PROBLEM IN GENERAL</u> .....   | 35        |
| B. <u>A DETAILED DISCUSSION OF COMMONALITY VERSUS INTEROPERABILITY</u> .....   | 35        |
| C. <u>ELEMENTS INFLUENCING COMMONALITY AND INTEROPERABILITY</u> .....  | 42        |
| 1. <u>Airframe Size and Groupings</u> .....  | 42        |
| 2. <u>Air Vehicle Control versus Mission Specific Payload Control</u> .....  | 44        |
| 3. <u>Human-Machine Interface</u> .....  | 46        |
| 4. <u>Hardware and Software Combination</u> .....  | 52        |
| 5. <u>Implementation through Retrofit or New Acquisition</u> .....   | 54        |
| 6. <u>Department of Defense Multiservice Cooperation</u> .....   | 56        |
| 7. <u>United States and Allied Cooperation</u> .....   | 58        |
| D. <u>AREAS IMPACTED BY COMMONALITY AND INTEROPERABILITY</u> .....   | 60        |
| 1. <u>Training</u> .....   | 60        |
| 2. <u>Basing</u> .....   | 62        |
| 3. <u>Manpower Requirements</u> .....  | 63        |
| 4. <u>Personnel Assignments</u> .....  | 64        |
| 5. <u>Reliability and Maintainability</u> .....  | 65        |
| 6. <u>Other Logistical Areas</u> .....   | 66        |
| 7. <u>Cost</u> .....   | 67        |
| 8. <u>Mission Capability</u> .....   | 69        |

|   |            |
|---|------------|
| <b>IV. <u>PROBLEM SCOPING</u></b> .....   | <b>71</b>  |
| <b>V. <u>TRAINING AS AN AREA OF INTEREST</u></b> .....  | <b>75</b>  |
| <b>A. <u>POTENTIAL BENEFITS FROM UAS AVO COMMON TRAINING</u></b> .....                          | 75         |
| <b>B. <u>OTHER GOVERNMENT EFFORTS TOWARD COMMON UAS TRAINING</u></b> .....                      | 76         |
| 1. <u>Joint Unmanned Aircraft Systems Center of Excellence</u> .....                            | 76         |
| 2. <u>Joint Unmanned Aircraft Systems Concept of Operations</u> .....                           | 78         |
| 3. <u>Joint Unmanned Aircraft Systems Levels of Qualification</u> .....                         | 79         |
| 4. <u>Chairman of the Joint Chiefs of Staff Instruction 3255.01</u> .....                       | 82         |
| 5. <u>Fleet UAS Platform Wholeness Concept of Operations</u> .....                              | 83         |
| <b>C. <u>NAV AIR AVIATION TRAINING SYSTEMS - ANALYSIS OF BASIC UAS QUALIFICATIONS</u></b> ..... | 84         |
| 1. <u>BUQ-I Analysis</u> .....  | 85         |
| 2. <u>BUQ-II Analysis</u> .....   | 86         |
| 3. <u>BUQ-III Analysis</u> .....  | 87         |
| 4. <u>BUQ-IV Analysis</u> .....   | 88         |
| 5. <u>BUQ-1 through IV (All) Analysis</u> .....   | 89         |
| <b>VI. <u>REQUIREMENTS ANALYSIS FOR A COMMON GCS</u></b> .....                                  | <b>91</b>  |
| <b>A. <u>OVERVIEW OF CURRENT NAVY UAS REQUIREMENTS</u></b> .....                                | 91         |
| 1. <u>Key Performance Parameters</u> .....  | 91         |
| 2. <u>Key System Attributes</u> .....   | 93         |
| 3. <u>CDD, CPD and System Specification Comparison</u> .....                                    | 94         |
| 4. <u>Commonality as a New Requirement</u> .....  | 97         |
| <b>B. <u>NECESSARY REQUIREMENTS FOR A COMMON GCS</u></b> .....                                  | 97         |
| 1. <u>Requirements Facilitating Common AVO Training</u> .....                                   | 97         |
| 2. <u>Additional Requirements for a Common GCS</u> .....  | 99         |
| <b>VII. <u>JUCCS PROPOSED COMMON GCS ARCHITECTURE</u></b> .....                                 | <b>105</b> |
| <b>A. <u>JUCCS ARCHITECTURAL ELEMENTS</u></b> .....   | 105        |
| 1. <u>Inspiration for the Architectural Structure</u> .....                                     | 105        |
| 2. <u>Enabling Common AVO Training</u> .....  | 106        |
| 3. <u>Enabling Interoperability</u> .....   | 106        |
| <b>B. <u>ARCHITECTURAL SYNTHESIS FROM AN AIR VEHICLE CONTROL PERSPECTIVE</u></b> .....          | 107        |
| 1. <u>UAS Elements and Functions</u> .....  | 108        |
| 2. <u>External Entities and Functions</u> .....   | 109        |
| <b>C. <u>CREATING THE JUCCS FUNCTIONAL ARCHITECTURE WITH BLOCK DIAGRAMS</u></b> ..              | 111        |
| 1. <u>Top Level Hierarchy of JUCCS Architecture</u> .....                                       | 112        |
| 2. <u>A1 Block Diagram: Perform GCS Functions</u> .....   | 113        |
| <b>D. <u>DOCUMENTING AND LINKING THE ARCHITECTURE WITH CORE</u></b> .....                       | 116        |
| <b>E. <u>JUCCS PROPOSED COMMON GCS ARCHITECTURE</u></b> .....                                   | 118        |
| 1. <u>A-1: External Systems Diagrams</u> .....  | 118        |
| 2. <u>A0: UAS Node Diagram</u> .....  | 120        |
| 3. <u>A1: Perform GCS Functions</u> .....   | 121        |
| 4. <u>A1.1: Provide Human Interface</u> .....   | 123        |
| 5. <u>A1.3: Manage Mission</u> .....  | 128        |

|  |            |
|--|------------|
| 6. A1.4: Command and Control Air Vehicle .....   | 130        |
| F. SUMMARY OF JUCCS ARCHITECTURE AND LINKAGE TO REQUIREMENTS .....                           | 134        |
| <b><u>VIII. IMPROVED TRAINING POSSIBILITIES WITH JUCCS COMMON GCS ARCHITECTURE</u></b> ..... | <b>139</b> |
| A. CURRENT NAVY UAS TRAINING PRACTICES .....   | 139        |
| 1. Navy Training System Plans .....  | 139        |
| 2. Current Navy UAS Training Concepts .....  | 142        |
| B. PROPOSED FUTURE NAVY UAS TRAINING PRACTICES .....   | 144        |
| 1. Expanded Analysis of Basic UAS Qualifications .....                                       | 145        |
| 2. Proposed Common Schoolhouse Navy UAS Pipelines .....                                      | 148        |
| 3. Quantitative Benefits Analysis of JUCCS Proposed Common GCS .....                         | 150        |
| C. SUMMARY OF COMMON UAS TRAINING BENEFITS .....   | 150        |
| D. CHALLENGES TO IMPLEMENTING COMMON UAS TRAINING .....                                      | 151        |
| <b><u>IX. CONCLUSIONS AND RECOMMENDATIONS</u></b> .....                                      | <b>153</b> |
| A. CONCLUSIONS .....   | 153        |
| B. RECOMMENDATIONS .....   | 155        |
| C. AREAS FOR FURTHER STUDY .....   | 157        |
| <b><u>APPENDIX A - PMP</u></b> .....   | <b>159</b> |
| <b><u>APPENDIX B - ACRONYMS</u></b> .....  | <b>193</b> |
| <b><u>LIST OF REFERENCES</u></b> .....   | <b>197</b> |
| INITIAL DISTRIBUTION LIST .....  | 203        |

## 2.0 SYSTEMS ENGINEERING APPROACH

The systems engineering approach will guide the methodology used by the JUCCS team throughout the project. This approach will be modified, as required, to ensure it is consistent with the current objectives for the project.

### 2.1 Overview

The systems engineering process the JUCCS team will employ is a tailored approach to the process discussed in *Systems Engineering Principles and Practice* (Kosiakoff & Sweet, 2003).

The higher level systems engineering process that is discussed in this reference can be seen in Figure 2-1. This process describes three phases of systems engineering as Concept

Development, Engineering Development and Post Development. For the purposes of the JUCCS project, much of the work will be contained in the Concept Development and Engineering Development phases.

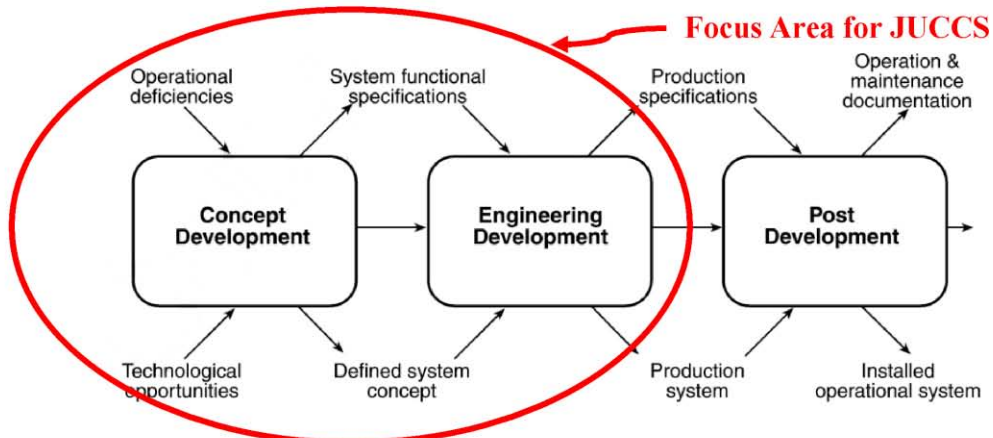

**Figure 2-1. Generic Systems Engineering Process (Kosiakoff & Sweet, 2003)**

*This figure shows the generic systems engineering process that was tailored for the JUCCS project. The process shows phases of Concept Development, Engineering Development and Post Development.*

The generic systems engineering process was then tailored specifically for the JUCCS project. The tailored process can be seen in Figure 2-2. This process is divided into the four phases of: Information Gathering and Problem Definition, Concept Development, Engineering Development, and Design Recommendations and Conclusions.

The process begins with Information Gathering and Problem Definition. Once the problem has been defined, the iterative phase of Concept Development commences. This iteration continues until an initial functional architecture has been defined that satisfies critical functional requirements. Next, the Engineering Development iterates until a final functional architecture has been defined that meets detailed requirements based on stakeholder feedback. Lastly, the Design Recommendations and Conclusions are produced. Problem scoping and stakeholder feedback loops are utilized throughout the process as shown in Figure 2-2.

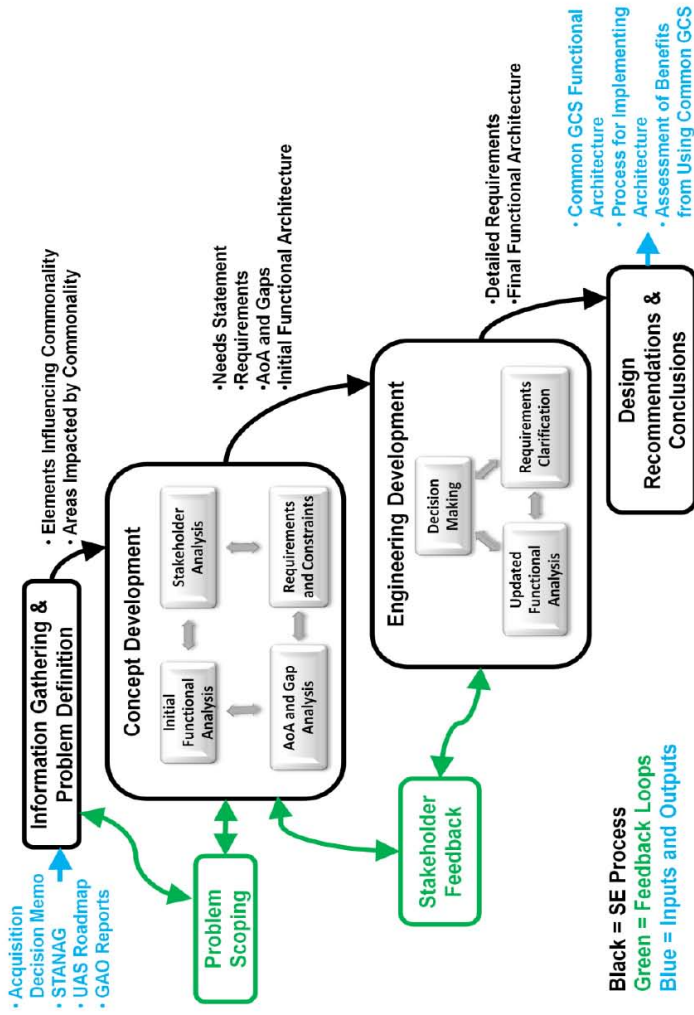

Figure 2-2. Tailored Systems Engineering Process for Team JUCCS

This figure is the tailored systems engineering process for the JUCCS project. The process is divided into four phases of Information Gathering & Problem Definition, Concept Development, Engineering Development and Design Recommendations & Conclusions.

## **2.2 Information Gathering and Problem Definition**

There are currently no statutory or funded Navy requirements for a common UAS GCS. The 11 February 2009 Memorandum from the Under Secretary of Defense for Acquisition, Technology, and Logistics (USD(AT&L), February 2009), calls for “adopting a common DoD architecture utilizing a core open architecture model.” However, this document does not levy any specific requirements. As part of this project the JUCCS team will define different levels of requirements for various levels of commonality. Possible definition and requirement suggestions will be identified during the problem definition phase of this project and documented accordingly. Additionally, existing systems will be researched to provide an adequate background for further studies during the information gathering phase.

## **2.3 Problem Scoping**

After the information gathering phase, an initial scoping of the problem will occur. This problem scoping will be iterative with the concept development phase to ensure the objectives of the program are achievable in the timeframe allowed.

## **2.4 Concept Development**

In the concept development phase, the JUCCS team will perform a stakeholder needs analysis to determine the requirements and priorities of the stakeholders. The initial step will be to ensure the correct set of stakeholders has been identified. The team will then elicit the stakeholders’ requirements and priorities potentially affected by GCS commonality. Requirements and constraints will then be defined and analyzed in relation to the defined problem statement. Use cases may be developed to assist with defining the common GCS architecture.

The JUCCS team will perform an analysis of alternatives for current functional and physical GCS architectures to determine functional capabilities and requirements for current UAS GCS systems. A gap analysis will be performed to identify gaps between the stakeholders’ elicited requirements and those of current GCS systems. An initial functional analysis of legacy

GCS architecture will be performed to identify all the critical functional requirements for common GCSs. This functional analysis will yield an initial functional architecture, but the functional analysis will not attempt to define a physical architecture for a common GCS.

## **2.5 Engineering Development**

A decision making process will be required to determine if an existing GCS architecture can be utilized to perform the proposed common GCS functions. If an existing GCS architecture meets the defined common functional requirements, it will be adopted for the JUCCS team use. If no existing GCS architecture can be adopted, the JUCCS team will design a new common GCS functional architecture as a final deliverable. This functional architecture will not produce a physical architecture for a common GCS.

## **2.6 Design Recommendations / Conclusions**

The final action in the defined systems engineering process will utilize information from the preceding phases to formulate recommendations on the future application of the proposed common GCS architecture to the stakeholders.

The final recommendations will include: a common GCS functional architecture, a process for implementing the architecture and a qualitative assessment of the benefits that could be realized by utilizing a common GCS framework.

The final recommendations will not include a detailed cost benefit analysis.

## **2.7 Tools**

A toolset of software programs will aid the JUCCS team throughout this project. Architecture development and SE functions will be documented and managed with Vitech's software program CORE. Scheduling will be accomplished with Microsoft Project. Modeling and simulation (as required) will utilize Microsoft Excel and ExtendSim. Word processing and presentation materials will utilize the Microsoft Office suite of products.

As the JUCCS project progresses, the toolset will be reevaluated to ensure compatibility with current program needs. New tools will be added as required to fulfill project objectives.

### 2.8 Risk Management

Risks to the JUCCS project will be documented and managed as they become known. Where necessary, a risk matrix as shown in Figure 2-3 will be used to communicate risks to the project advisors. All attempts will be made to properly scope the problem to avoid project risks. Risks that cannot be avoided will be the responsibility of the program management IPT for appropriate mitigation.

Risk will be managed in accordance with the Risk Management Guide for DoD Acquisition (NAVAIR, January 2008).

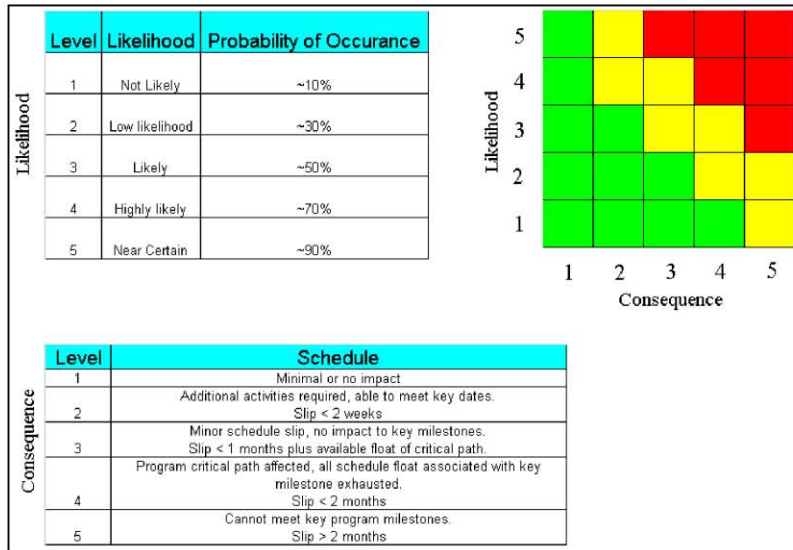
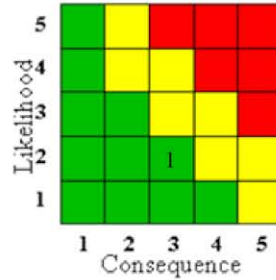

Figure 2-3. Sample DoD Risk Matrix Format, based on (NAVAIR, January 2008)

The DoD risk matrix shows risks as a likelihood vs. consequence per the specification tables. The likelihood and consequences are defined on the left side of the figure, while the risks are located on the risk matrix in the upper right portion of the figure.

**2.8.1 Risks**

The JUCCS team’s current risks are listed below and will be continually evaluated and updated as appropriate.



**Figure 2-4. JUCCS Project Current Risks**

*This risk matrix shows the current risks associated with the JUCCS program. The risk matrix will be updated as new risks are discovered.*

**Risk 1: JUCCS Team Will Not Produce Deliverable by March, 2010 (L2, C3)**

- Description of risk: If the JUCCS team does not produce a final deliverable by March 2010, then master’s degrees are not conveyed on time.
- Statement of cause: The JUCCS team must properly scope the objective and achieve a sound technical baseline from which to manage tradeoffs and project solutions within the allotted timeframe.
- Consequence if risk is realized: Exit criteria for MSSE program will not be conveyed on time.

**2.8.2 Issues**

Any risk that is realized becomes an issue and will be focused on separately to minimize the effects.

### **3.0 DELIVERABLES AND SCHEDULE**

The JUCCS program deliverables and schedules are defined per this section. The schedule will be continuously updated as the project progresses.

#### **3.1 IPRs and Deliverables**

Table 3-1 lists each IPR and milestone associated with the JUCCS project. The stakeholders and the JUCCS team must agree that the required deliverable(s) are completed satisfactorily before an IPR is considered complete.

#### **3.2 Schedule**

The schedule for the JUCCS project is provided in Figure 3-1.

**Table 3-1. List of IPRs and Deliverables.**

*The listing of program deliverables is shown in this table. These deliverables were extracted from the original problem statement provided to the team by the NPS advisors.*

| <i>Deliverable Number</i> | <i>Description</i>   | <i>Deliverable</i>                      | <i>Date</i>        |
|---------------------------|--|---|--------------------|
| <b>Pre-IPR 1</b>          | <b>PMP Approval</b>  | <b>Project Management Plan</b>          | <b>3 Sep 2009</b>  |
| <b>IPR 1</b>              | <b>Problem Background</b>                                    |   | <b>24 Sep 2009</b> |
|                           | Information Gathering and Problem Definition                 |   |                    |
| a.                        | Elements Influencing Commonality                             | Written Description of Elements         | <b>24 Sep 2009</b> |
| b.                        | Areas Impacted by Commonality                                | Written Description of Impacts          | <b>24 Sep 2009</b> |
| c.                        | Scoped Problem   | Project Problem Statement               | <b>24 Sep 2009</b> |
| <b>IPR 2</b>              | <b>Iterative Systems Engineering Process</b>                 |   | <b>17 Dec 2009</b> |
|                           | Concept Development  |   |                    |
| a.                        | Stakeholder/Needs Analysis                                   | Report of Needs Analysis                | <b>17 Dec 2009</b> |
| b.                        | Requirements and Constraints Analysis                        | Report of Requirements and Constraints  | <b>17 Dec 2009</b> |
| c.                        | Analysis of Alternatives of Current Operational Architecture | Report of Alternatives and Architecture | <b>17 Dec 2009</b> |
| d.                        | Functional Analysis  | Report of Functional Analysis           | <b>17 Dec 2009</b> |
|                           | Engineering Development                                      |   |                    |
| a.                        | Requirements Clarification                                   | Detailed Requirements                   | <b>17 Dec 2009</b> |
| b.                        | Updated Functional Analysis                                  | Functional Analysis                     | <b>17 Dec 2009</b> |
| c.                        | Functional Architecture                                      | Functional Architecture                 | <b>17 Dec 2009</b> |
| <b>Final Report</b>       | <b>Report Delivery &amp; Project Presentation</b>            |   | <b>25 Mar 2010</b> |
| a.                        | Design Recommendations                                       | Design Recommendations                  | <b>25 Mar 2010</b> |
| b.                        | Project Summary  | Project Summary                         | <b>25 Mar 2010</b> |

JUCCS Project Management Plan

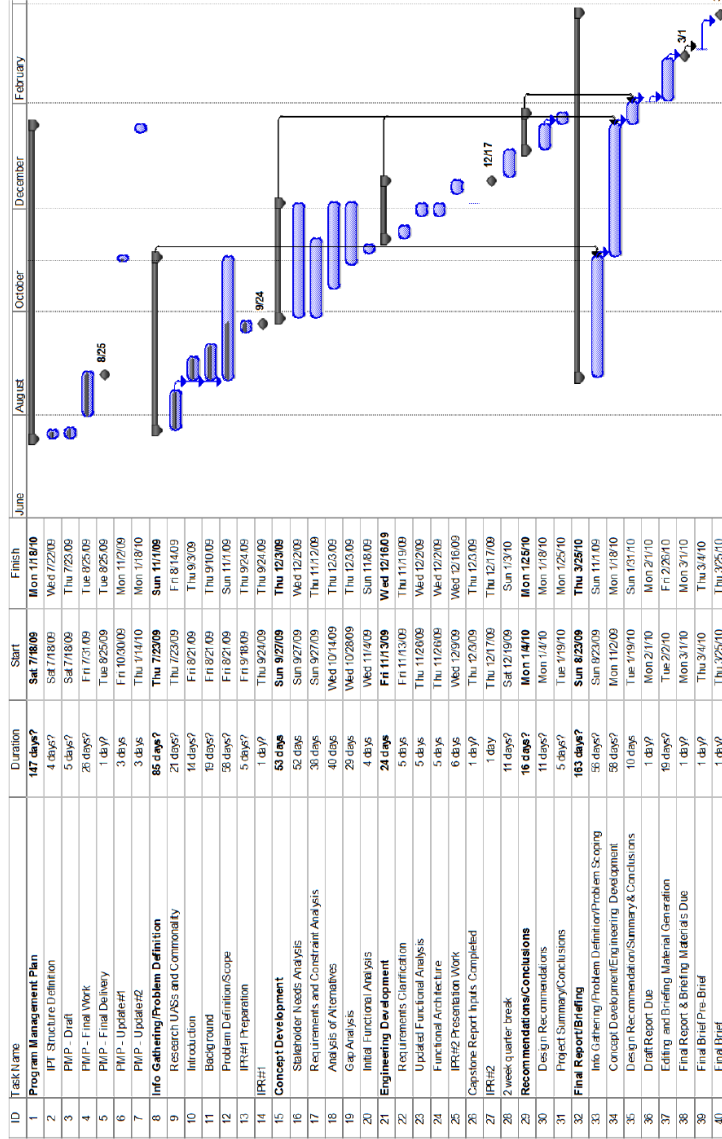

Figure 3-1. JUCCS Project Plan

The schedule for the JUCCS project can be seen in this figure. The present time is shown by the vertical line spanning all of the tasks. Future deliverables along with their respective start and finish dates and durations are listed.

#### 4.0 ACRONYMS

| <u>Acronym</u> | <u>Term</u>                                       |
|----------------|---|
| ADM            | Acquisition Decision Memorandum                   |
| BAMS           | Broad Area Maritime Surveillance                  |
| C2             | Command and Control                               |
| CAIV           | Cost as an Independent Variable                   |
| CNO            | Chief of Naval Operation                          |
| DoD            | Department of Defense                             |
| DON            | Department of Navy                                |
| GAO            | Government Accountability Office                  |
| GCS            | Ground Control Station                            |
| INCOSE         | International Council on Systems Engineering      |
| IPR            | Interim Project Reviews                           |
| IPT            | Integrated Product Team                           |
| ISR            | Intelligence, Surveillance, and Reconnaissance    |
| JCIDS          | Joint Capabilities Integration Development System |
| JUCCS          | Joint UAS Common Control Station                  |
| MSSE           | Masters of Systems Engineering                    |
| NAVAIR         | Naval Air Systems Command                         |
| NPS            | Naval Postgraduate School                         |
| OPTEVFOR       | Operational Test and Evaluation Force             |
| OT&E           | Operational Test and Evaluation                   |
| PEO            | Program Executive Office                          |
| PM             | Program Manager                                   |
| PMP            | Project Management Plan                           |
| R&M            | Reliability and Maintainability                   |
| RDT&E          | Research, Development, Test and Evaluation        |
| SE             | Systems Engineering                               |
| STANAG         | Standard Agreement                                |
| U&W            | Unmanned Aviation and Weapons                     |
| UAS            | Unmanned Air or Aircraft (or Air) Systems         |

| <u>Acronym</u> | <u>Term</u>  |
|----------------|--|
| UAV            | Unmanned Aerial Vehicle  |
| UCAS           | Unmanned Combat Air Systems  |
| USD (AT&L)     | Under Secretary of Defense of Acquisition, Technology, and Logistics |
| VTUAV          | Vertical Take-off and Land Tactical UAV                              |

## 5.0 WORKS CITED

GAO. (April 2006). *GAO-06-610T: Unmanned Aircraft Systems: Improved Planning and Acquisition Strategies Can Help Address Operational Challenges.*

GAO. (July 2009). *GAO-09-520: Defense Acquisitions: Opportunities Exist to Achieve Greater Commonality and Efficiencies among Unmanned Aircraft Systems.*

Kossiakoff, A., & Sweet, W. (2003). *Systems Engineering Principles and Practice.* John Wiley and Sons, Inc.

NATO. (November 2007). *STANAG 4586.* Standardization Agreement.

NAVAIR. (January 2008). *NAVAIR Instruction 5000.21B - Program/Project Risk Management.*

NAVAIR. (August 2009). *NAVAIR Website.* Retrieved 2009, from [www.navair.navy.mil](http://www.navair.navy.mil)

NPS. (May 2009). *Memorandum for MSSE Cohort 311-0832 Students.*

USD(AT&L). (February 2009). *Unmanned Aircraft Systems (UAS) Ground Control Station (GCS) Acquisition Decision Memorandum (ADM).*

USD(AT&L). (April 2009). *Unmanned Systems Integrated Roadmap, FY 2009-2034.*

THIS PAGE INTENTIONALLY LEFT BLANK

APPENDIX B: JUCCS TEAM LOGO



THIS PAGE INTENTIONALLY LEFT BLANK

## APPENDIX C: DEFINITION OF AIRSPACES

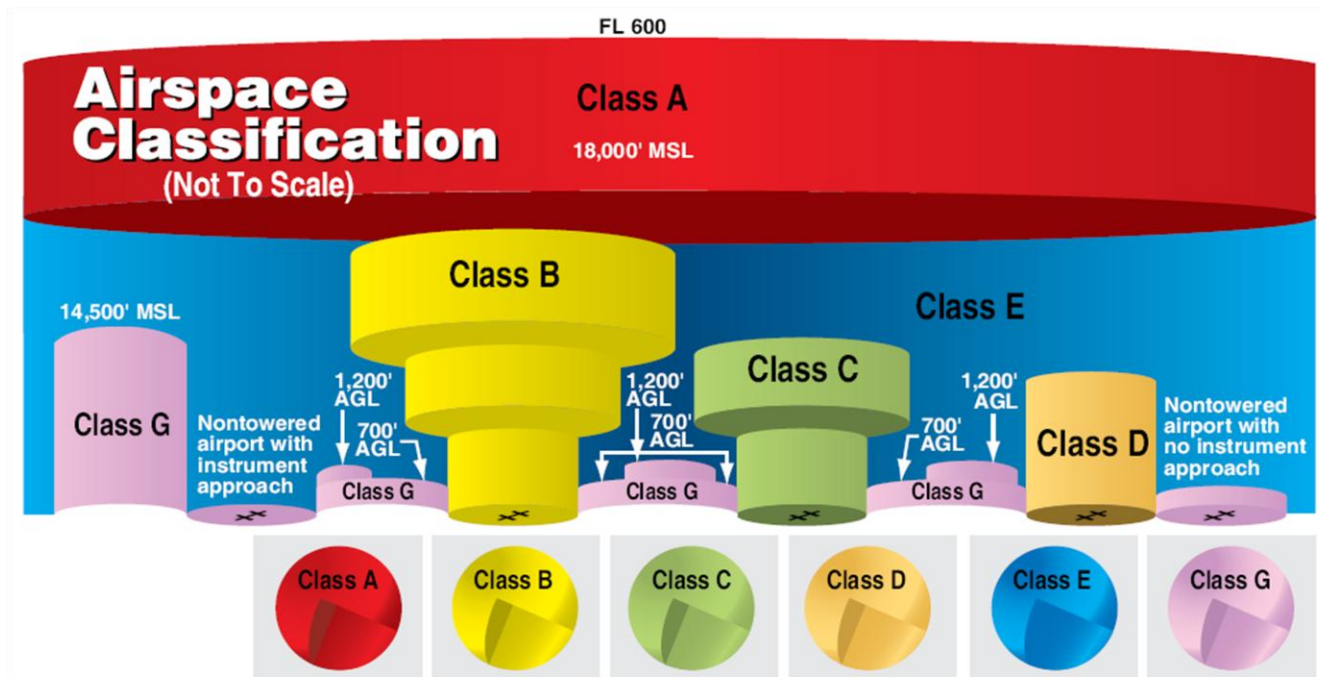

- Class A: Generally, airspace from 18,000 feet mean sea level (MSL) up to and including flight level (FL) 600 (i.e. 60,000 ft.)
- Class B: Generally, airspace from the surface to 10,000 feet MSL surrounding the nation's busiest airports.
- Class C: Generally, airspace from the surface to 4,000 feet above the airport elevation (charted in MSL) surrounding those airports that have an operational control tower, are serviced by a radar approach control, and have a certain number of IFR operations.
- Class D: Generally, that airspace from the surface to 2,500 feet above the airport elevation (charted in MSL) surrounding those airports that have an operational control tower.
- Class E: Generally, if the airspace is not Class A, B, C, or D, and is controlled airspace, then it is Class E airspace.
- Class G: Airspace not designated as Class A, B, C, D, or E. Class G airspace is essentially uncontrolled by ATC except when associated with a temporary control tower.

•Chart and words from Federal Aviation Administration (FAA) document number FAA-H-8083-15A, *Instrument Flying Handbook*, 2008 chapter 8

THIS PAGE INTENTIONALLY LEFT BLANK

## APPENDIX D: COMPLETE BUQ ANALYSIS

| BUQ | Category            | KSA   | Training with common HMI | Training with Current Interfaces |
|-----|---------------------|---|--------------------------|----------------------------------|
| I   | Mission Preparation | Aviation Weather                            | C                        | C                                |
| I   | Mission Preparation | Aircraft Performance Data/Limitations       | C                        | C                                |
| I   | Mission Preparation | CRM and Communications                      | C                        | C                                |
| I   | Mission Preparation | Publications                                | C                        | C                                |
| I   | Mission Preparation | Emergency Equip/IFE Procedures              | C                        | C                                |
| I   | Mission Preparation | Departure and Arrival Planning              | C                        | C                                |
| I   | Mission Preparation | Flight Checklists and Use                   | C                        | C                                |
| I   | Mission Preparation | Computerized Flight Planning Systems        | C                        | C                                |
| I   | Mission Preparation | Charts – Sectional, Tactical, Global        | C                        | C                                |
| I   | Mission Preparation | Mission Route Selection & Analysis          | C                        | C                                |
| I   | Mission Preparation | ICAO/FLIP Procedures                        | C                        | C                                |
| I   | Communications      | Communications planning and management      | C                        | C                                |
| I   | Communications      | Data Links                                  | C                        | C                                |
| I   | Communications      | Knowledge of Airborne Communication Systems | C                        | C                                |
| I   | Aircraft Operations | Weather Hazards                             | C                        | C                                |
| I   | Aircraft Operations | Basic Manual Navigation                     | C                        | C                                |
| I   | Aircraft Operations | General Flight Rules                        | C                        | C                                |
| I   | Aircraft Operations | Low Level Flying                            | C                        | C                                |
| I   | Aircraft Operations | Fuel Planning                               | C                        | C                                |
| I   | Aircraft Operations | Aircraft Systems and Directives             | C                        | C                                |
| I   | Aircraft Operations | Integrated Navigation Systems               | C                        | C                                |
| I   | Aircraft Operations | Emergency Procedures                        | C                        | C                                |
| I   | Aircraft Operations | Aviation Principles                         | C                        | C                                |
| I   | Aircraft Operations | Manual Flight Control Skills                | C                        | C                                |
| I   | Aircraft Operations | Time & Course Control                       | C                        | C                                |
| I   | Air Operations      | Air Tasking Orders (ATO)                    | C                        | C                                |
| I   | Before Flight       | VFR Mission planning                        | C                        | C                                |
| I   | Before Flight       | Exterior inspection checks                  | Unique                   | Unique                           |
| I   | Before Flight       | Weather data for mission planning           | C                        | C                                |
| I   | Before Flight       | Appropriate communications procedures       | C                        | Unique                           |
| I   | Before Flight       | Operational data for mission planning       | C                        | C                                |
| I   | Before Flight       | Starting engines checks                     | C                        | Unique                           |
| I   | Before Flight       | Mission briefing                            | C                        | C                                |
| I   | Before Flight       | Verbal communication/radio procedures       | C                        | Unique                           |
| I   | Before Flight       | Map preparation for use during flight       | C                        | Unique                           |
| I   | Before Flight       | GPS position checks                         | C                        | Unique                           |
| I   | Before Flight       | Route planning to destination & alternates  | C                        | Unique                           |
| I   | Before Flight       | Pre-flight clearances                       | C                        | C                                |
| I   | Before Flight       | Enroute altitudes IAW FLIP                  | C                        | C                                |
| I   | Before Flight       | GCS instrument checks                       | C                        | Unique                           |
| I   | Before Flight       | Preflight checks                            | C                        | Unique                           |
| I   | Before Flight       | Before takeoff checks                       | C                        | Unique                           |
| I   | Before Flight       | Maintenance logs                            | C                        | C                                |
| I   | Contact             | Recognize departure and recovery procedures | C                        | Unique                           |
| I   | Contact             | Controlling Rate of Descent                 | C                        | Unique                           |
| I   | Contact             | Appropriate climb airspeed                  | C                        | Unique                           |
| I   | Contact             | Use of local area map for orientation       | C                        | Unique                           |
| I   | Contact             | Establishing and maintaining altitude       | C                        | Unique                           |
| I   | Contact             | Clearing turns                              | C                        | Unique                           |
| I   | Contact             | Applicable in-flight checks                 | C                        | Unique                           |
| I   | Contact             | Slow flight                                 | C                        | Unique                           |
| I   | Contact             | Turns, climbs, descents, as required        | C                        | Unique                           |
| I   | Contact             | Approach to field checks                    | C                        | Unique                           |
| I   | Contact             | Level off checks                            | C                        | Unique                           |

|   |              |   |        |        |
|---|--------------|---|--------|--------|
| I | Contact      | Basic aero maneuvers  | C      | Unique |
| I | Contact      | Basic area orientation  | C      | Unique |
| I | Contact      | Before descent checks   | C      | Unique |
| I | Contact      | Current wind conditions   | C      | Unique |
| I | Contact      | Automatic approach & landing  | C      | Unique |
| I | Contact      | Touch & go landing  | C      | Unique |
| I | Contact      | Approach to landing   | C      | Unique |
| I | Contact      | Go-around on final approach turn  | C      | Unique |
| I | Contact      | Landing & rollout procedures  | C      | Unique |
| I | Contact      | Airspeed change, straight-and-level as required.                                | C      | Unique |
| I | Contact      | Go-around/missed approach checks  | C      | Unique |
| I | Contact      | Go-ahead from final approach/flare  | C      | Unique |
| I | Contact      | Post landing checks & procedures  | C      | Unique |
| I | Contact      | GCS safety procedures   | C      | Unique |
| I | Contact      | Flight line and air discipline  | C      | Unique |
| I | Contact      | Normal traffic pattern  | C      | Unique |
| I | Contact      | Final approach procedures   | C      | Unique |
| I | Contact      | Traffic pattern deconfliction   | C      | Unique |
| I | Contact      | Takeoff, initial climb & associated checks                                      | C      | Unique |
| I | Contact      | Clearing airspace in direction of turn  | C      | Unique |
| I | Contact      | Maneuvering within assigned airspace  | C      | Unique |
| I | Contact      | Aircraft configuration: Pre-landing checks                                      | C      | Unique |
| I | Contact      | Airmanship, judgment, & decision-making in aircraft (GCS-Situational awareness) | C      | Unique |
| I | Contact      | Unusual attitudes and recovery techniques                                       | C      | Unique |
| I | Contact      | Stalls and recovery procedures  | C      | Unique |
| I | Contact      | Normal overhead and straight-in patterns, as appropriate                        | C      | Unique |
| I | Contact      | Altitude/attitude control throughout flight                                     | C      | Unique |
| I | Navigation   | Visual navigation   | C      | Unique |
| I | Navigation   | Correlation of aircraft position with map                                       | C      | Unique |
| I | Navigation   | Map reading   | C      | Unique |
| I | Navigation   | Calculation actual fuel consumption   | C      | Unique |
| I | Navigation   | Using visual landmarks in flight planning                                       | C      | Unique |
| I | Navigation   | In-flight navigation planning   | C      | Unique |
| I | Navigation   | Calculation/compensation for in-flight winds                                    | C      | Unique |
| I | Navigation   | Time and fuel management  | C      | Unique |
| I | Navigation   | Calculation of new estimated time of arrival (ETA)                              | C      | Unique |
| I | Navigation   | Lost communication/C2 link procedures   | C      | Unique |
| I | Emergency    | Emergency conditions  | Unique | Unique |
| I | Emergency    | Analyzing current situation, including systems for possible emergency           | Unique | Unique |
| I | Emergency    | Aircraft control during emergency conditions                                    | Unique | Unique |
| I | Emergency    | Recognition of applicable emergency procedures                                  | Unique | Unique |
| I | Emergency    | Communication/declaration of an emergency (if required)                         | C      | C      |
| I | Emergency    | Recognition and proper response to unplanned lost C2 link events                | C      | Unique |
| I | Emergency    | Land as soon as conditions permit   | C      | Unique |
| I | After Flight | After landing checks  | C      | Unique |
| I | After Flight | Completion flight time logs   | C      | C      |
| I | After Flight | Engine shutdown check   | C      | Unique |
| I | After Flight | Completion maintenance logs   | C      | C      |
| I | After Flight | All safety procedures for securing aircraft                                     | Unique | Unique |
| I | After Flight | Post landing procedures   | Unique | Unique |

|    |                     |  |   |        |
|----|---------------------|--|---|--------|
| II | Aircraft Operations | Radio Aid Navigation   | C | Unique |
| II | Aircraft Operations | Radar Navigation/Fixing  | C | Unique |
| II | Before Flight       | Compute takeoff and landing data   | C | C      |
| II | Before Flight       | Clearance to taxi  | C | C      |
| II | Before Flight       | Local VFR flight clearance   | C | C      |
| II | Before Flight       | Clearance for takeoff  | C | C      |
| II | Before Flight       | ICE-T/ground speed   | C | C      |
| II | Before Flight       | Taxiing to runway  | C | Unique |
| II | Before Flight       | Filing DD 175/ICAO 1801 (Flight Plan)  | C | C      |
| II | Before Flight       | Taxiing into takeoff position  | C | Unique |
| II | Before Flight       | Interior inspection check  | C | Unique |
| II | Before Flight       | Line up checks   | C | Unique |
| II | Before Flight       | Before taxi check  | C | Unique |
| II | Before Flight       | Operation of navigation radios   | C | Unique |
| II | Contact             | Appropriate climb per manuals (Tech order climb)   | C | Unique |
| II | Contact             | Requesting and receiving landing clearance   | C | C      |
| II | Contact             | Basic departure procedures   | C | Unique |
| II | Contact             | Local breakout procedures  | C | Unique |
| II | Contact             | Leveling off from tech order climb   | C | Unique |
| II | Contact             | Closed pattern   | C | Unique |
| II | Navigation          | Position reporting   | C | Unique |
| II | Navigation          | Usage of Pilot to Metro Service (PMSV), Air Traffic Information Service (ATIS), and Pilot Report (PIREP) | C | C      |
| II | Navigation          | In-flight clearances   | C | C      |
| II | Navigation          | Interpretation of radio weather condition report   | C | C      |
| II | Navigation          | Dead reckoning navigation  | C | Unique |
| II | Navigation          | Navigation diversions based on weather reports   | C | C      |
| II | Navigation          | Actual and planned rate of fuel consumption  | C | Unique |
| II | Navigation          | Comparing actual and planned groundspeeds  | C | C      |
| II | After Flight        | Taxiing clear of runway  | C | Unique |
| II | After Flight        | Closing a flight plan with ATC   | C | C      |
| II | After Flight        | Taxiing to parking   | C | Unique |

|     |                     |  |   |        |
|-----|---------------------|--|---|--------|
| III | Aircraft Operations | Instrument Flight  | C | Unique |
| III | Aircraft Operations | Instrument Flight Procedures   | C | Unique |
| III | Before Flight       | Instrument Flight Rules (IFR) mission planning   | C | C      |
| III | Before Flight       | Obtaining an IFR clearance   | C | C      |
| III | Before Flight       | Operation of Air Traffic Surveillance Equipment (IFF/SIF/TCAS/Sense and Avoid Sensors)         | C | Unique |
| III | Instrument          | Partial panel instrument flight  | C | Unique |
| III | Instrument          | Aircraft maneuvers under instrument conditions   | C | Unique |
| III | Instrument          | Recognition of improper nose low condition   | C | Unique |
| III | Instrument          | Course intercept   | C | Unique |
| III | Instrument          | Rate of intercept  | C | Unique |
| III | Instrument          | Angle of intercept   | C | Unique |
| III | Instrument          | Recognition and recovery from unusual attitudes under instrument conditions                    | C | Unique |
| III | Instrument          | Operation of aircraft instruments and navigation equipment                                     | C | Unique |
| III | Instrument          | Hazardous/adverse weather conditions in flight   | C | Unique |
| III | Instrument          | Weather phenomena which affect flight  | C | C      |
| III | Instrument          | Establishing and maintaining constant altitude, airspeed, and heading during instrument flight | C | Unique |
| III | Navigation          | Unfamiliar field departure procedures  | C | C      |
| III | Navigation          | Low level navigation   | C | Unique |
| III | Navigation          | Unfamiliar field visual and instrument approach procedures                                     | C | C      |

|    |                     |  |   |        |
|----|---------------------|--|---|--------|
| IV | Mission Preparation | Global Flight Ops Knowledge  | C | C      |
| IV | Communications      | Satellite Communications (SATCOM)                                  | C | Unique |
| IV | Aircraft Operations | Global Navigation Procedures                                       | C | Unique |
| IV | Air Operations      | Search and Rescue (SAR)  | C | C      |
| IV | Instrument          | Auto/instrument takeoff, climb, & departure procedures             | C | Unique |
| IV | Instrument          | Departing a holding pattern  | C | Unique |
| IV | Instrument          | Instrument cross check   | C | Unique |
| IV | Instrument          | Procedure turns  | C | Unique |
| IV | Instrument          | Intercepting a heading at a predetermined angle                    | C | Unique |
| IV | Instrument          | Transitioning from MDA to runway                                   | C | Unique |
| IV | Instrument          | Establishing and maintaining appropriate heading                   | C | Unique |
| IV | Instrument          | ATC/approach control clearances                                    | C | Unique |
| IV | Instrument          | Determination of lead point  | C | Unique |
| IV | Instrument          | Standard instrument approach plate procedures                      | C | Unique |
| IV | Instrument          | Course interception  | C | Unique |
| IV | Instrument          | Procedure turn airspace  | C | Unique |
| IV | Instrument          | IFR navigation   | C | Unique |
| IV | Instrument          | En route descents  | C | Unique |
| IV | Instrument          | Fix-to-fix navigation  | C | Unique |
| IV | Instrument          | Appropriate Landing configuration                                  | C | Unique |
| IV | Instrument          | Maintaining selected course with wind correction                   | C | Unique |
| IV | Instrument          | Descent gradients  | C | Unique |
| IV | Instrument          | Knowledge of establishing arc                                      | C | Unique |
| IV | Instrument          | Instrument Meteorological Conditions (IMC) penetration             | C | Unique |
| IV | Instrument          | Arc interception   | C | Unique |
| IV | Instrument          | ATC clearances   | C | C      |
| IV | Instrument          | Arc maintenance  | C | Unique |
| IV | Instrument          | ATC procedures   | C | C      |
| IV | Instrument          | Radial interception from arc                                       | C | Unique |
| IV | Instrument          | Remaining within cleared airspace                                  | C | Unique |
| IV | Instrument          | Holding /loitering   | C | Unique |
| IV | Instrument          | Controlling Rate of Descent  | C | Unique |
| IV | Instrument          | Understanding holding instructions                                 | C | Unique |
| IV | Instrument          | Instrument approach procedures                                     | C | Unique |
| IV | Instrument          | Holding pattern entry  | C | Unique |
| IV | Instrument          | Radar patterns   | C | Unique |
| IV | Instrument          | Maintaining position within holding pattern airspace               | C | Unique |
| IV | Instrument          | Following Ground Controlled Approach (GCA) controller's directions | C | Unique |
| IV | Instrument          | Wind analysis in holding pattern airspace                          | C | Unique |
| IV | Instrument          | Turning to directed headings                                       | C | Unique |
| IV | Instrument          | Maintaining directed altitudes                                     | C | Unique |
| IV | Instrument          | Glide slope control  | C | Unique |
| IV | Instrument          | Maintaining proper airspace  | C | Unique |
| IV | Instrument          | Course control   | C | Unique |
| IV | Instrument          | Establishing proper holding configuration                          | C | Unique |
| IV | Instrument          | Transitioning from instruments to visual references                | C | Unique |
| IV | Instrument          | Precision radar approach   | C | Unique |
| IV | Instrument          | Visual Descent Point (VDP)   | C | Unique |
| IV | Instrument          | Non-precision radar approach                                       | C | Unique |
| IV | Instrument          | Circling approach procedures                                       | C | Unique |
| IV | Instrument          | Gyro-out instrument pattern  | C | Unique |
| IV | Instrument          | Missed approach procedures   | C | Unique |
| IV | Instrument          | Half-standard rate turns on final                                  | C | Unique |
| IV | Instrument          | ATC missed approach clearances                                     | C | Unique |
| IV | Instrument          | Gyro-out precision radar approach                                  | C | Unique |
| IV | Instrument          | Missed approach checks   | C | Unique |
| IV | Instrument          | Corrections to aircraft heading                                    | C | Unique |
| IV | Instrument          | Transitioning from glide path to runway                            | C | Unique |
| IV | Instrument          | In-flight IFR clearance  | C | C      |

## APPENDIX E: DETAILED LOGIC FOR QUANTITATIVE ANALYSIS

Justification for the logic found in the table was based on research from many sources, including: *Naval Unmanned Aircraft Systems (UAS) Family of Systems (FoS) (Groups 1-5) Common/Core Training Requirements Study Brief* [PMA-205, 2009], a thesis titled *A Comparative Analysis of the Army MQ-8B Fire Scout Vertical Takeoff Unmanned Aerial Vehicle (VTUAV) and Navy MQ-8B Manpower & Training Requirements* [Raymer, 2009], another thesis titled *An Operational Manpower Analysis of the RQ-8 Fire Scout Vertical Take-Off Unmanned Aerial Vehicle (VTUAV)* [Stracker, 2007], the *Naval Air Warfare Center Aircraft Division Fiscal Year 2010 Customer Stabilized Rates* [NAWCAD, 2009], a draft report that was done for PMA-205 by MITRE and AIR 4.6, and discussions with AIR 4.6 and CAPT Schmidt.

| Category                        | Logic   |
|---------------------------------|---|
| Number of training sites        | The number of training sites for the existing distributed schoolhouse concept is based on data from the Navy Training System Plans for the respective programs [PMA-205, 2008] and [PMA-205, 2007]. The common schoolhouse concepts utilize one training site.  |
| Total number of simulators      | Existing training concepts are assumed to have two simulators per site to ensure training capability when one is down for maintenance. This assumption is based on the Navy Training System Plans for the respective programs [PMA-205, 2008] and [PMA-205, 2007]. The common schoolhouse number of simulators is notionally based on data from the throughput of 115 total students per year. Assuming 60 students at one time during a course of six months, four simulators would be needed to accommodate periods of two hours per simulator with two students per simulator working in teams. To more accurately predict the numbers of simulators required, more detailed analysis is required on the actual training plan for the BUQs and a more realistic throughput value per week. |
| Total annual simulator O&S cost | Assumptions for O&S costs were based on the concept that the simulators will need few corrective and preventative maintenance actions. The simulators are assumed to be designed and manufactured using a majority of COTS components. The COTS components include processors, memory, displays, keyboards, trackballs, etc. The reliability is assumed to be high with little in the way of preventative maintenance. Included in the estimate were costs for one technician full time at NAWCAD FY10 Civilian Band 2 rates, maintenance costs to replace defective simulator components, software updates to correct deficiencies and incorporate improvements, and preventative maintenance.   |

| Category                           | Logic  |
|------------------------------------|--|
| Total annual courseware management | <p>This includes the costs involved to manage all required courseware per year. A single set is comprised of all printed material, software, and databases. Using best engineering judgment based on current practices the JUCCS cohort assumed that there would be two updates per year for the courseware. Two updates are manageable and would probably not interfere with pipeline training goals. A technician to perform archiving, maintenance, and updates based on NAWCAD FY10 Civilian Band 2 rates. Contractor provided course management, software modifications, computer based training, and part task training. The contractor support needs more detailed analysis and is dependent on how the training is contracted. If the Navy decided to utilize a prime contractor for all training instead of a smaller contractor, the costs would be different.</p>   |
| Total annual infrastructure cost   | <p>The basis of this estimate was calculated with values from CNATTU Norfolk [Hernandez, 2010]. The calculations were based on one simulator in 3000 sq ft of space, 10 Navy and Marine Corps Internet (NMCI) supported computers in 1000 sq ft of classroom space, and both spaces being in a controlled environment for improved reliability. The NMCI computers support is estimated at approximately \$4,000 per computer seat, per year. The infrastructure cost for the space includes the energy requirements that include electrical, HVAC, and steam. The energy costs were calculated to be \$12,800 per year. An additional cost was calculated for Public Works to maintain the space for preventative and corrective maintenance at \$5,000 per year. Total infrastructure costs are estimated at \$57, 800 per site, per year. Estimates for BAMS, Fire Scout, and the common schoolhouse concepts were multiples based on the required number of simulators and computers. It was estimated that the number of simulators per site for the BAMS and Fire Scout models were two, doubling the infrastructure costs from \$57,800 to \$115,600. The common schoolhouse models would require four simulators per site and the cost would increase roughly four times to \$231,200.</p> |
| Total number of instructors        | <p>The number of instructors per site was based on best engineering judgment by the JUCCS cohort after review of NTSPs and discussions with NAVAIR AIR 4.6. The BAMS and Fire Scout programs are to require six instructors per site to handle throughput requirements. The instructors will probably have collateral duties assigned when not training and further analysis is required to calculate the actual manpower requirements. The common schoolhouse calculations by PMA-205 were based on estimating double the number of BAMS and Fire Scout instructors at a single site to handle the throughput of two separate, but collocated training cohorts. The JUCCS approach calculated less based on an estimated 96 percent common training syllabus. A more accurate estimate is recommended for future work on the common approaches.</p>   |
| Total annual instructor cost       | <p>The cost of the instructors was based on the NAWCAD Civilian Pay Band 4 FY10 rate that is a professionally trained person with either a BS or MS degree and experience. If an active duty instructor were utilized then a different value would need to be calculated.</p>  |

| Category   | Logic  |
|--|--|
| Total number of support and administration personnel   | The number of support and administrative personnel per site was based on best engineering judgment by the JUCCS cohort after review of NTSPs and discussions with NAVAIR 4.6. The number of support and administrative personnel includes training, personnel, and maintenance scheduling, maintaining training records, and other clerical and support functions. The current number of support and administrative personnel for BAMS and Fire Scout was predicted at nine per site IAW current research. The common schoolhouse estimate by PMA-205 was eight and JUCCS was four based on best engineering judgment and related literature. The JUCCS concept will require fewer personnel due to the common training elements, which will have common training records and syllabi. |
| Total annual support and administration personnel cost | The cost of the instructors was based on the NAWCAD Civilian Pay Band 2 FY10 rate that is a professionally administrative assistant with either an AA or BA degree and experience.   |
| Total annual O&S cost                                  | This is the total annual cost to operate each approach. It takes into account the total number of sites, the number of distinct UASs taught at each site, and the number of simulators at each site.   |

THIS PAGE INTENTIONALLY LEFT BLANK

## **APPENDIX F: ACROYMNS**

| <u>Acronym</u> | <u>Term</u>  |
|----------------|--|
| ADM            | Acquisition Decision Memorandum  |
| AGL            | Above Ground Level   |
| AIAA           | American Institute of Aeronautics and Astronautics                                       |
| AMP            | Aviation Mission Package   |
| AOC            | Air Operations Center  |
| AOI            | Area of Interest   |
| ASCII          | American Standard Code for Information Interchange                                       |
| ATC            | Air Traffic Control  |
| ATM            | Air Traffic Management   |
| ATO            | Air Tasking Order  |
| AV             | Air Vehicle  |
| AVO            | Air Vehicle Operator   |
| BAMS           | Broad Area Maritime Surveillance   |
| BRAC           | Base Realignment and Closure   |
| BUPERS         | Bureau of Naval Personnel  |
| BUQ            | Basic UAS Qualification  |
| C2             | Command and Control  |
| C4I            | Command, Control, Communication, Computer & Intelligence                                 |
| C4ISR          | Command, Control, Communication, Computer, Intelligence, Surveillance and Reconnaissance |
| CAS            | Close Air Support  |
| CBR            | Chemical, Biological, and Radiological   |
| CBT            | Computer Based Training  |
| CCI            | Command and Control Interface  |
| CCISM          | Command and Control Interface Specific Module  |
| CDD            | Capability Development Document  |
| CDL            | Common Data Link   |

| <u>Acronym</u> | <u>Term</u>                                       |
|----------------|---|
| CJCS           | Chairman of the Joint Chiefs of Staff             |
| CJCSI          | Chairman of the Joint Chiefs of Staff Instruction |
| CNO            | Chief of Naval Operation                          |
| CNSF           | Commander Naval Surface Forces                    |
| COCOM          | Combat Command                                    |
| COI            | Contact of Interest                               |
| CONOPS         | Concept of Operations                             |
| CONUS          | Continental United States                         |
| COTS           | Commercial Off The Shelf                          |
| CPD            | Capability Production Document                    |
| DEAD           | Destruction of Enemy Air Defenses                 |
| DLI            | Data Link Interface                               |
| DoD            | Department of Defense                             |
| DODAF          | Department of Defense Acquisition Framework       |
| DoN            | Department of Navy                                |
| E3             | Electromagnetic Environmental Effects             |
| EFFBD          | Enhanced Functional Flow Block Diagram            |
| EO/IR          | Electro-Optical/Infra-Red                         |
| EW             | Electronic Warfare                                |
| FAA            | Federal Aviation Administration                   |
| FL             | Flight Level                                      |
| FOB            | Forward Operation Bases                           |
| FoS            | Family of Systems                                 |
| FSS            | Flight Service Station                            |
| FY             | Fiscal Year                                       |
| GAO            | Government Accountability Office                  |
| GCS            | Ground Control Station                            |
| GIG            | Global Information Grid                           |
| GSI            | Ground Segment Interface                          |
| HCI            | Human Computer Interface                          |

| <u>Acronym</u> | <u>Term</u>  |
|----------------|--|
| HMD            | Helmet Mounted Display                                       |
| HMI            | Human-Machine Interface                                      |
| HSC            | Helicopter Sea Combat  |
| HSM            | Helicopter Marine Strike                                     |
| IAA            | Incident Awareness and Assessment                            |
| ICOM           | Inputs, Controls, Outputs, and Measures                      |
| IDEF           | Integration Definition for Functional Modeling               |
| IFF            | Identification Friend or Foe                                 |
| IOC            | Initial Operational Capability                               |
| IPR            | Interim Project Reviews                                      |
| IPT            | Integrated Product Team                                      |
| ISR            | Intelligence, Surveillance, and Reconnaissance               |
| JCS            | Joint Chiefs of Staff  |
| JCIDS          | Joint Capabilities Integration Development System            |
| JFC            | Joint Forces Commander                                       |
| JIPT           | Joint Integrated Product Team                                |
| JMPS           | Joint Mission Planning System                                |
| JMQ            | Joint Mission Qualification                                  |
| JMTL           | Joint Mission Task List                                      |
| JPATS          | Joint Primary Air Training System                            |
| JROC           | Joint Requirements Oversight Council                         |
| JSF            | Joint Strike Fighter   |
| JUAS COE       | Joint Unmanned Aircraft Systems Center of Excellence         |
| JUCAS          | Joint Unmanned Combat Air System                             |
| JUCCS          | Joint UAS Common Control Station – Team name for this Cohort |
| JUMTS          | Joint UAS Minimum Training Standards                         |
| KFOR           | Kosovo Forces  |
| KPP            | Key Performance Parameter                                    |
| KSA            | Knowledge Skills and Abilities                               |
| LCC            | Life Cycle Costs   |

| <u>Acronym</u> | <u>Term</u>                                   |
|----------------|---|
| LCS            | Littoral Combat Ship                          |
| LOI            | Level of Interoperability                     |
| LOS            | Line of Sight                                 |
| LRE            | Launch & Recovery Elements                    |
| MBSE           | Model Based Systems Engineering               |
| MC             | Mission Commander                             |
| MESF           | Maritime Expeditionary Security Force         |
| MILCON         | Military Construction                         |
| MMA            | Multi-Mission Maritime Aircraft               |
| MMH            | Maintenance Man-Hours                         |
| MOB            | Main Operating Base                           |
| MPO            | Mission Payload Operator                      |
| MPRF           | Maritime Patrol And Reconnaissance Force      |
| MSL            | Mean Sea Level                                |
| MSRON          | Maritime Expeditionary Security Squadron      |
| MSSE           | Masters of Systems Engineering                |
| MTD            | Mission Training Device                       |
| MTT            | Mobile Training Team                          |
| MTTR           | Mean Time To Repair                           |
| MUT            | Manned-Unmanned Teaming                       |
| NAS            | Naval Air Station                             |
| NASA           | National Aeronautics and Space Administration |
| NATO           | North Atlantic Treaty Organization            |
| NAVAIR         | Naval Air Systems Command                     |
| NDIA           | National Defense Industrial Association       |
| NECC           | Navy Expeditionary Combat Command             |
| NOTAM          | Notice to Airmen                              |
| NPS            | Naval Postgraduate School                     |
| NTSP           | Navy Training System Plan                     |
| O&S            | Operations and Sustainment                    |

| <u>Acronym</u> | <u>Term</u>   |
|----------------|---|
| OPM            | Office of Personnel Management                                |
| OSCE           | Organization for Security and Cooperation in Europe           |
| OSD            | Office of the Secretary of Defense                            |
| OSGCS          | One System Ground Control Station                             |
| OTH            | Over the Horizon  |
| PBS            | Performance Based Specification                               |
| PDA            | Personal Data Assistant                                       |
| PEO            | Program Executive Office                                      |
| PEO (U&W)      | Program Executive Office Unmanned Aviation and Strike Weapons |
| PID            | Positive Identification                                       |
| PM             | Project Manager   |
| PMA-205        | NAVAIR Training Systems Program Office                        |
| PMA-262        | NAVAIR Persistent Maritime UAS Program Office                 |
| PMA-263        | NAVAIR Small Tactical UAS Program Office                      |
| PMA-266        | NAVAIR Multi-Mission Tactical UAS Program Office              |
| PMA-268        | NAVAIR Unmanned Combat Air System Program Office              |
| R&D            | Research and Development                                      |
| R&M            | Reliability and Maintainability                               |
| RF             | Radio Frequency   |
| RTSA           | Reconnaissance, Surveillance, and Target Acquisition          |
| S&I IPT        | Standards and Interoperability IPT                            |
| SA             | Situational Awareness   |
| SAR            | Synthetic Aperture Radar                                      |
| SATCOM         | Satellite Communication                                       |
| SE             | Systems Engineering   |
| SEAD           | Suppression of Enemy Air Defenses                             |
| SIGINT         | Signal Intelligence Gathering                                 |
| SINCGARS       | Single Channel Ground and Airborne Radio System               |
| STANAG         | Standard Agreement  |

| <u>Acronym</u> | <u>Term</u>  |
|----------------|--|
| STUAS          | Small Tactical Unmanned Air System                                   |
| TCAS           | Traffic Collision Avoidance System                                   |
| TCDL           | Tactical Common Data Link  |
| TCS            | Tactical Control Station   |
| TIMS           | Training Integration Management System                               |
| TOI            | Target of Interest   |
| TST            | Time Sensitive Targeting   |
| TTP            | Tactics, Techniques, and Procedures                                  |
| TYCOM          | Type Commander   |
| U&W            | Unmanned Aviation and Weapons  |
| UAS            | Unmanned Air or Aircraft Systems                                     |
| UASFCS         | UAS Flight Crew Skills   |
| UASMCS         | UAS Mission Crew Skills  |
| UAV            | Unmanned Aerial Vehicle  |
| UCAS           | Unmanned Combat Air System   |
| UCS            | UAV Control System   |
| UGV            | Unmanned Ground Vehicle  |
| UHF            | Ultra High Frequency   |
| UMS            | Unmanned Maritime Systems  |
| USAF           | United States Air Force  |
| USD(AT&L)      | Under Secretary of Defense of Acquisition, Technology, and Logistics |
| USFFC          | United States Fleet Forces Command                                   |
| USJFCOM        | United States Joint Forces Command                                   |
| USMC           | United States Marine Corps   |
| USN            | United States Navy   |
| VFR            | Visual Flight Rules  |
| VSM            | Vehicle Specific Module  |
| VTUAV          | Vertical Take-off and Land Tactical UAV                              |
| WBT            | Web-Based Training   |

## LIST OF REFERENCES

AAI Corp. (2009). *One For All: The One System*.

AeroVironment Inc. (2009). *UAS Ground Control Station*. Retrieved September 2009, from <http://www.avinc.com>

Aviation Week. (2009). Retrieved September 2009, from Aviation Week:  
<http://www.aviationweek.com/aw/>

Blanchard, B. S., & Fabrycky, W. J. (2006). *Systems Engineering and Analysis*. Upper Saddle River: Pearson Prentice Hall.

Boeing Commercial Airplanes. (2009). *Component Repair and Leasing Service*. Seattle.

Braman, M. T. (1997). *Privatization of Military Repair Depots*. Air Command and Staff College.

Buede, D. M. (2009). *The Engineering Design of Systems: Models and Methods*. Hoboken: John Wiley & Sons.

Catington, R. C., Knudson, O. A., & Yodzis, J. B. (2000). *Transatlantic Armaments Cooperation*. Fort Belvoir, VA: Defense Systems Management College Press.

CDL Systems. (2009). *NATO STANAG 4586*. Retrieved September 2009, from The Next Generation in Unmanned Vehicle Control:  
<http://www.cdlsystems.com/index.php/stanag4586>

CJCS. (2009). *CJCSI 3255.01: Joint Unmanned Aircraft Systems Minimum Training Standards*.

Colt, J. (2009, December 18). Joint Unmanned Aircraft Systems Center of Excellence Presentation.

Crowder, G. L. (1992). *Evaluation of the Cost Effectiveness Analysis Model Being Developed for the Component Improvement Programs of the Air Force and the Navy*. Naval Postgraduate School.

Cummings, M. L. (2008, August). Of Shadows and White Scarves. *C4ISR Journal*.

Cummings, M. L., Kirschbaum, A. R., Sulmistras, A., & Platts, J. T. (2006). STANAG 4586, Human Supervisory Control Implications. *Unmanned Vehicle Systems Canada Conference*. Montebello, Quebec.

Dam, S. H. (2006). *DoD Architecture Framework: A Guide to Applying System Engineering to Develop Integrated, Executable Architectures*. Marshall, VA: SPEC.

Defense Update. (2009). Retrieved September 2009, from Defense Update - Online Defense Magazine: <http://defense-update.com/>

DoD. (1981). *MIL-HDBK-189: Reliability Growth Management*.

DoD. (2008). *MIL-STD-2525C: Common Warfighting Symbolology*.

DoN. (1998). *OPNAVINST 1000.16J: Manual of Navy Total Force Manpower Policies and Procedures*. Office of the Chief of Naval Operations.

Erwin, S. I. (2003, October). UAV Programs Need Common Standards, Says Industry Study. *National Defense Magazine* .

FAA. (2008). *FAA-H-8083-15A: Instrument Flying Handbook*.

Figueras, R. (2007). *Product Support for a Commercial Derivative*. Boeing.

Firebaugh, M. S. (2009, July). U.S. Losing Critical Skills Needed to Weaponize Unmanned Systems. *National Defense* , p. 31.

GAO. (1985). *GAO/NSIAD 85-50: Separate Army and Air Force Airborne SINCGARS Programs May be Uneconomical*. Washington DC.

GAO. (March 2005). *GAO-05-395T: Improved Strategic and Acquisition Planning Can Help Address Emerging Challenges*.

GAO. (December 2005). *GAO-06-49: Unmanned Aircraft Systems: DoD Needs to More Effectively Promote Interoperability and Improve Performance Assessments*.

GAO. (2006). *GAO-06-610T: Unmanned Aircraft Systems: Improved Planning and Acquisition Strategies Can Help Address Operational Challenges*.

GAO. (2009). *GAO-09-520: Defense Acquisitions: Opportunities Exist to Achieve Greater Commonality and Efficiencies among Unmanned Aircraft Systems*.

Gill, L. (2003). *F-35 Joint Strike Fighter Autonomic Logistics Supply Chain*. Lockheed Martin.

Global Security. (1999). *Joint Primary Aircraft Training System (JPATS)*. Retrieved September 2009, from GlobalSecurity.org: <http://www.globalsecurity.org/military/library/budget/fy1999/dot-e/airforce/99jpats.html>

Globe Newswire Inc. (2009). *Recently Published Photos*. Retrieved September 2009, from <http://media.primezone.com>

Held, T., Newsome, B., & Lewis, M. W. (2008). *Commonality in Military Equipment: A Framework to Improve Acquisition Decisions*. Santa Monica: Rand Arroyo Center.

Hernandez, C. (2010, February 18). Email discussion with CNATTU about infrastructure costs. Norfolk, Virginia.

Hewson, R. (2006, July 21). Navy UCAS Program Set to be Launched Within Weeks. *Aviation Week* .

IHS (Global) Limited. (2009). Retrieved September 2009, from Jane's:  
<http://search.janes.com/Search/index.jsp>

Independant Defence Consultant. (2009). Retrieved September 2009, from Defence Consultant: <http://defenceconsultant.co.nz/>

JCS. (2009). *Joint Publication 1-02: Department of Defense Dictionary of Military and Associated Terms*. Department of Defense.

JCS. (2006). Joint Unmanned Aircraft System Center of Excellence: NDIA Conference.

Jean, G. V. (December 2008). Army, Air Force to Operate Armed Drones in Tandem. *National Defense Magazine* .

Jean, G. V. (July 2008). Eglin Prepares to Open F-35 Training Center. *National Defense Magazine* .

Jean, G. V. (2009, January). Ground Control. *National Defense Magazine* .

JROC. (2008). *STUAS Tier II UAS Capability Development Document*.

Knowledge Based Systems, Inc. (2010). *IDEF0 Function Modeling Method*. Retrieved January 10, 2010, from <http://www.idef.com/idef0.html>

Kossiakoff, A., & Sweet, W. (2003). *Systems Engineering Principles and Practice*. John Wiley and Sons, Inc.

Lydall, B., & Wickens, C. (2005). Mixed Fleet Flying Between Two Commercial Aircraft Types: An Empirical Evaluation of the Role of Negative Transfer. *Proceedings of the Human Factors and Ergonomics Society , 49th Annual Meeting*.

Merriam-Webster, Inc. (2009). Retrieved September 2009, from Merriam-Webster Online Dictionary: <http://www.merriam-webster.com/>

Morphew, Shively, & Casey. (2004). Helmet-Mounted Displays for Unmanned Aerial Vehicle Control. *International Society for Optics and Photonics (SPIE)*, (pp. 93-103).

NASA. (2010). *Virtual Skies: Air Traffic Management System*. Retrieved January 18, 2010, from <http://virtualskies.arc.nasa.gov/main/matm.html>

NATO. (2007). *STANAG 4586*. Standardization Agreement.

NATO. (2004). *STANAG 7085 - Interoperable Datal Links for Intelligence, Surveillance, and Reconnaissance (ISR) Systems*.

Navy Personnel Command. (2004). *NAVPERS 18068F: Manual of Navy Enlisted Manpower and Personnel Classifications and Occupational Standards*.

NAWCAD. (2009). *Naval Air Warfare Center Aircraft Division Fiscal Year 2010 Customer Stabilized Rates*.

NDIA. (2003). *NDIA Common UAV Architecture Study - Final Report Executive Summary*. National Defense Industrial Association (NDIA).

Nellis Air Force Base. (2010). *JUAS Center of Excellence*. Retrieved January 16, 2010, from <http://www.nellis.af.mil/units/uascenterofexcellence.asp>

Nobelius, D., & Sundgren, N. (2002). Managerial Issues in Parts Sharing Among Product Development Projects: A Case Study. *Journal of Engineering and Technology* , 19 (1), 50-73.

Northrop Grumman Systems Corporation. (2007). *System Specification For The Fire Scout MQ-8B Vertical Take-Off And Landing Tactical Unmanned Aerial Vehicle (VTUAV)*.

OSD. (2009). *FY2009-2034 Unmanned Systems Integrated Roadmap*.

OSD. (2002). *Unmanned Aerial Vehicles Roadmap 2002-2027*.

OSD. (2005). *Unmanned Aircraft Systems Roadmap 2005-2030*.

OSD. (2007). *Unmanned Systems Roadmap (2007-2032)*.

PEO(U&W). (2009). *Common Systems Integration*.

PMA-205. (2008). *N88-NTSP-A-50-0004/A: Navy Training System Plan for the Vertical Takeoff and Landing Tactical UAV (VTUAV) System*.

PMA-205. (2007). *N88-NTSP-A-50-0403/D: Navy Training System Plan for the Broad Maritime Surveillance (BAMS) UAS*.

PMA-205. (2009, October 15). *Naval Unmanned Aircraft Systems (UAS) Family of Systems (FoS) (Groups 1-5) Common/Core Training Requirements Study Brief*.

- PMA-262. (2009). *Airspace Integration Brief*.
- PMA-263. (2007). *Capability Development Document for Broad Area Maritime Surveillance Unmanned Aircraft System*.
- PMA-263. (2008). *Capability Production Document (CPD) for Vertical Takeoff and Landing Tactical UAV (VTUAV) System*.
- PMA-263. (2009). *Performance Based Specification (PBS) for Small Tactical UAS/Tier II UAS*.
- PMA-299. (2009, October). *Partnering Across Acquisition Programs/Industry to Implement Common Cockpit*. Retrieved from Department of the Navy Research, Development & Acquisition:  
[https://acquisition.navy.mil/rda/home/acquisition\\_one\\_source/program\\_assistance\\_and\\_tools/best\\_practices\\_and\\_lessons\\_learned](https://acquisition.navy.mil/rda/home/acquisition_one_source/program_assistance_and_tools/best_practices_and_lessons_learned)
- Raymer, M. K. (2009). *A Comparative Analysis of the Army MQ-8B Fire Scout Vertical Takeoff Unmanned Aerial Vehicle (VTUAV) and Navy MQ-8B Manpower & Training Requirements*. Naval Postgraduate School.
- Saiz, R., & Lewandowski, D. (2008). *UAS in NATO: Fostering Transformation, The JAPCC Perspective of UAS in NATO*. Joint Air Power Competence Centre.
- Shalal-Esa, A. (2009, August 12). Demand for UAVs predicted to fuel market for years to come. *AIA Daily Lead*.
- Sheffi, Y. (2005). *The Resilient Enterprise: Overcoming Vulnerability for Competitive Advantage*. Cambridge, MA: MIT Press.
- Smith, S. A., & Oren, S. S. *Reliability Growth of Repairable Systems*. Palo Alto, CA: Analysis Research Group.
- Stracker, M. (2007). *An Operational Manpower Analysis of the RQ-8 Fire Scout Vertical Take-Off Unmanned Aerial Vehicle (VTUAV)*. Naval Postgraduate School.
- Treacy, M., & Wiersema, F. (1994). *The Discipline of Market Leaders: Choose Your Customers, Narrow Your Focus, Dominate Your Market*. Boston: Addison-Wesley Publishing.
- U.S. OPM. (2010). *Policies and Instructions - General Policies: Explanation of Terms*. Retrieved February 28, 2010, from U.S. Office of Personnel Management:  
<http://www.opm.gov/qualifications/policy/Terms.asp>
- USD(AT&L). (2008). *DoD Instruction 5000.02: Operation of the Defense Acquisition System*.

USD(AT&L). (2009). *Unmanned Aircraft Systems (UAS) Ground Control Station (GCS) Acquisition Decision Memorandum (ADM)*.

USFFC. (2009). *DRAFT - Fleet Unmanned Aircraft System (UAS) Platform Wholeness Concept of Operations*.

USJFCOM. (2008). *JUAS COE R 112008-8: Joint Concept of Operations for Unmanned Aircraft Systems*.

USMC Combat Development Command. (2009). *Concept of Operations for United States Marine Corps Unmanned Aircraft Systems Family of Systems*.

Van Dyke, B. (1990). AIAA 90-3249 - Joint Unmanned Aerial Vehicle Family Interoperability and Commonality. *AIAA/AHS/ASEE Aircraft Design, Systems and Operations Conference*. Dayton: AIAA.

Warwick, G., & Chavanne, B. H. (2009, August 10). Open Architecture for UAV Ground Control. *Aviation Week* .

## INITIAL DISTRIBUTION LIST

1. Defense Technical Information Center  
Ft. Belvoir, Virginia
2. Dudley Knox Library  
Naval Postgraduate School  
Monterey, California
3. Richard Millar  
Naval Postgraduate School  
Patuxent River, Maryland
4. Gregory Miller  
Naval Postgraduate School  
Monterey, California
5. John Schmidt  
Naval Postgraduate School  
Monterey, California