



AFRL-RY-WP-TP-2009-1308

A MODULATION BASED APPROACH TO WIDEBAND-STAP (POSTPRINT)

Ke Yong Li, Unnikrishna S. Pillai, Peter Zulch, and Michael Callahan

C & P Technologies, Inc.

OCTOBER 2007

Approved for public release; distribution unlimited.

See additional restrictions described on inside pages

STINFO COPY

© 2007 IEEE

**AIR FORCE RESEARCH LABORATORY
SENSORS DIRECTORATE
WRIGHT-PATTERSON AIR FORCE BASE, OH 45433-7320
AIR FORCE MATERIEL COMMAND
UNITED STATES AIR FORCE**

REPORT DOCUMENTATION PAGE				<i>Form Approved</i> OMB No. 0704-0188	
<p>The public reporting burden for this collection of information is estimated to average 1 hour per response, including the time for reviewing instructions, searching existing data sources, gathering and maintaining the data needed, and completing and reviewing the collection of information. Send comments regarding this burden estimate or any other aspect of this collection of information, including suggestions for reducing this burden, to Department of Defense, Washington Headquarters Services, Directorate for Information Operations and Reports (0704-0188), 1215 Jefferson Davis Highway, Suite 1204, Arlington, VA 22202-4302. Respondents should be aware that notwithstanding any other provision of law, no person shall be subject to any penalty for failing to comply with a collection of information if it does not display a currently valid OMB control number. PLEASE DO NOT RETURN YOUR FORM TO THE ABOVE ADDRESS.</p>					
1. REPORT DATE (DD-MM-YY) October 2007		2. REPORT TYPE Conference Paper Postprint		3. DATES COVERED (From - To) 25 May 2006 – 19 October 2007	
4. TITLE AND SUBTITLE A MODULATION BASED APPROACH TO WIDEBAND-STAP (POSTPRINT)				5a. CONTRACT NUMBER FA8750-06-C-0117	
				5b. GRANT NUMBER	
				5c. PROGRAM ELEMENT NUMBER 62204F	
6. AUTHOR(S) Ke Yong Li (C & P Technologies, Inc.) Unnikrishna S. Pillai (Polytechnic University) Peter Zulch (AFRL/RIEC) Michael Callahan (AFRL/RVRT)				5d. PROJECT NUMBER 5017	
				5e. TASK NUMBER RL	
				5f. WORK UNIT NUMBER 517R1511	
7. PERFORMING ORGANIZATION NAME(S) AND ADDRESS(ES) C & P Technologies, Inc. 317 Harrington Avenue Suites 9 & 10 Closter, NJ 07624-1911 ----- Polytechnic University Brooklyn, NY 11201				8. PERFORMING ORGANIZATION REPORT NUMBER	
Communications Exploitation Branch (AFRL/RIEC) Information and Intelligence Exploitation Division Air Force Research Laboratory 525 Brooks Road, Rome, NY 13441-4505 United States Air Force ----- Radar Signal Processing Branch (AFRL/RVRT) RF Sensor Technology Division Air Force Research Laboratory, Sensors Directorate Wright-Patterson Air Force Base, OH 45433-7320 Air Force Materiel Command, United States Air Force					
9. SPONSORING/MONITORING AGENCY NAME(S) AND ADDRESS(ES) Air Force Research Laboratory Sensors Directorate Wright-Patterson Air Force Base, OH 45433-7320 Air Force Materiel Command United States Air Force				10. SPONSORING/MONITORING AGENCY ACRONYM(S) AFRL/RVRT	
				11. SPONSORING/MONITORING AGENCY REPORT NUMBER(S) AFRL-RY-WP-TP-2009-1308	
12. DISTRIBUTION/AVAILABILITY STATEMENT Approved for public release; distribution unlimited.					
13. SUPPLEMENTARY NOTES Conference paper published in the Proceedings of the 41st Annual Asilomar Conference on Signals, Systems, and Computers, held November 04 - 07, 2007 at the Asilomar Hotel and Conference Grounds, Pacific Grove, CA. PAO Case Number: WPAFB 07-0238; Clearance date: 01 Nov 2007. Briefing contains color. See also, AFRL-RY-WP-TP-2009-1306 for a briefing chart version, and AFRL-RY-WP-TP-2009-1307 for a preprint version. © 2007 IEEE. The U.S. Government is joint author of this work and has the right to use, modify, reproduce, release, perform, display, or disclose the work. Paper contains color.					
14. ABSTRACT In this paper, a new method for processing wideband radar data is presented. To perform the full degree of freedom wideband processing, 3-D space-time adaptive processing (STAP) needs to be implemented, which involves intense computational burden. One approach in this case is to do subband STAP processing and combine these outputs. In this paper, instead of traditional subband processing, the incoming wideband data signal is modulated by multiple carriers, combined, and filtered prior to processing using narrowband STAP. This method offers a significant decrease in computation burden compared to the subband method.					
15. SUBJECT TERMS wideband space-time adaptive processing					
16. SECURITY CLASSIFICATION OF:			17. LIMITATION OF ABSTRACT: SAR	18. NUMBER OF PAGES 12	19a. NAME OF RESPONSIBLE PERSON (Monitor) Michael J. Callahan 19b. TELEPHONE NUMBER (Include Area Code) N/A
a. REPORT Unclassified	b. ABSTRACT Unclassified	c. THIS PAGE Unclassified			

A Modulation Based Approach to Wideband-STAP

Ke Yong Li¹, Unnikrishna S. Pillai², Peter Zulch³, and Michael Callahan⁴

¹C & P Technologies, Inc., Closter, NJ 07624, kli@cptrj.com

²Polytechnic University, Brooklyn, NY 11201, pillai@hora.poly.edu

³Air Force Research Laboratory (AFRL), Rome, NY 13441, zulchp@rl.af.mil

⁴AFRL, Wright-Patterson AFB, OH 45433, Michael.Callahan@wpafb.af.mil

Abstract— In this paper, a new method for processing wideband radar data is presented. To perform the full degree of freedom wideband processing, 3-D space-time adaptive processing (STAP) needs to be implemented, which involves intense computational burden. One approach in this case is to do subband STAP processing and combine these outputs. In this paper, instead of traditional subband processing, incoming wideband data signal is modulated by multiple carriers, combined, and filtered prior to processing using narrowband STAP. This method offers a significant decrease in computation burden compared to the subband method.

I. INTRODUCTION

One way to understand the wideband data is to consider it as a collection of narrowband data scenes. Recall that the narrowband data vector $\underline{x}_k(t)$ for an N sensor, M pulse array has the form [1]

$$\underline{x}_k(t) = \sum_i \sum_j \alpha_{i,j} A(\theta_{i,j}, \omega_k) \underline{s}(\theta_{i,j}, \omega_k) \quad (1)$$

where $\alpha_{i,j}$ represents the clutter scatter return from the $(i, j)^{th}$ patch in the field of view, $A(\theta_{i,j}, \omega_k)$ the array factor at frequency ω_k . Here $\underline{s}(\theta_{i,j}, \omega_k)$ represents the spatio-temporal steering vector at frequency ω_k given by

$$\underline{s}(\theta_{i,j}, \omega_k) = \underline{b}(\theta_{i,j}, \omega_k) \otimes \underline{a}(\theta_{i,j}, \omega_k) \quad (2)$$

where the spatial steering vector is $\underline{a}(\theta, \omega_k)$ is given by

$$\underline{a}(\theta, \omega_k) = [1, e^{-j\pi d \sin \theta / \lambda_k}, \dots, e^{-j\pi(N-1)d \sin \theta / \lambda_k}]^T \quad (3)$$

and the temporal steering vector $\underline{b}(\omega_{d_k}, \omega_k)$ is given by

$$\underline{b}(\omega_{d_k}, \omega_k) = [1, e^{-j\pi \omega_{d_k}}, \dots, e^{-j\pi(M-1)\omega_{d_k}}]^T. \quad (4)$$

Here d represents the interelement spacing distance and Doppler ω_{d_k} is given by

$$\omega_{d_k} = \frac{2V \sigma T_r}{\lambda_k / 2} \sin \theta. \quad (5)$$

In (2) - (5), λ_k refers to the operating wavelength, V the platform velocity along the line of the array and T_r represents the pulse repetition interval. With $\underline{x}_k(t)$ in (1) representing the k^{th} narrowband data, and $\underline{x}(t)$ the desired wideband data, we have

$$\underline{x}(t) = \sum_{k=1}^K \underline{x}_k(t). \quad (6)$$

With $\underline{c}(t)$ representing the received wideband clutter data and $\underline{f}(t)$ representing the received wideband target data, the total receiver signal in (6) can be written as

$$\underline{x}(t) = \underline{f}(t) + \underline{c}(t). \quad (7)$$

Assume that the target is moving with a relative velocity V at an arrival angle of θ_o (both parameters are unknown), the $MN \times 1$ target signal $\underline{f}(t)$ have the form of

$$f_{ik}(t) = f(t - (i-1)T_1 - (k-1)T_2) \quad (8)$$

where the spatial delay T_1 is given by

$$T_1 = \frac{d \sin \theta_o}{c} \quad (9)$$

and the temporal delay T_2 is given by

$$T_2 = \frac{2V T_r \sin \theta_o}{c}. \quad (10)$$

Hence the target return has the form

$$\underline{f} = [\underline{f}_1, \underline{f}_2, \dots, \underline{f}_M]^T \quad (11)$$

where \underline{f}_m represents the m^{th} pulse return given by

$$\underline{f}_m = [f(t - (M-1)T_2), \dots, f(t - (M-1)T_2 - (N-1)T_1)]. \quad (12)$$

In the wideband case, the optimum processor is a whitening filter $\mathbf{H}(z)$ followed by a matched filter [2]. This whitening processing is shown in Fig. 1. The white noise $\underline{w}(t)$ in Fig. 1 represents the whitened interference.

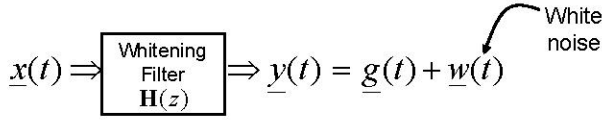

Fig. 1 Whitening of wideband data.

Using (7) - (12), in the frequency domain, the whitening filter output is given by

$$\begin{aligned} \underline{Y}(\omega) &= F(\omega)\mathbf{H}(e^{j\omega}) \begin{bmatrix} 1 \\ e^{-j\omega T_1} \\ \vdots \\ e^{-j\omega(N-1)T_1} \\ e^{-j\omega T_2} \underline{a}(\theta, \omega) \\ \vdots \\ e^{-j\omega(M-1)T_2} \underline{a}(\theta, \omega) \end{bmatrix} + \underline{w}(\omega) \\ &= \underline{b}(V, \omega) \otimes \underline{a}(\theta, \omega) = \underline{s}(\theta, V, \omega) \\ &= F(\omega)\mathbf{H}(e^{j\omega})\underline{s}(\theta, V, \omega) + \underline{w}(\omega) = \underline{g} + \underline{W} \end{aligned} \quad (13)$$

where \underline{g} represents the target output and \underline{w} represents the interference output. In this case, the matched filter is given by \underline{g}^* . Thus the optimum wideband processor can be shown as in Fig. 2.



Fig. 2 Optimum wideband processor.

As a first approximation, if we use a narrowband like whitening filter with a constant term, then

$$\mathbf{H}(z) = \mathbf{R}_c^{-1/2}, \quad (14)$$

where

$$\mathbf{R}_c = E\{\underline{c}(t)\underline{c}^*(t)\} > 0 \quad (15)$$

represents the interference/clutter covariance matrix. In that case, the output of the optimum wideband processor is given by

$$\begin{aligned} Z &= \underline{g}^* \underline{Y}(\omega) \\ &= (\underline{s}^*(\theta, V, \omega) \mathbf{R}_c^{-1/2}) (\mathbf{R}_c^{-1/2} \underline{X}(\omega)) \\ &= \underline{s}^*(\theta, V, \omega) \mathbf{R}_c^{-1} \underline{X}(\omega) = \underline{W}^*(\omega) \underline{X}(\omega) \end{aligned} \quad (16)$$

where $\underline{W}^*(\omega)$ represents the optimum wideband STAP processor and it is given by

$$\underline{W}(\omega) = \mathbf{R}_c^{-1} \underline{s}(\theta, V, \omega). \quad (17)$$

Notice that the optimum wideband STAP processor in (17) has the same form as in the narrowband case. However, it is a frequency sensitive processor and it is difficult to implement at all frequencies simultaneously. When the whitening filter $\mathbf{H}(z)$ involves delay-lines, the structure in (17) becomes more complex.

In summary, the phase delays in wideband STAP processor become frequency sensitive filters. The optimum wideband processor must be compensated at all frequencies simultaneously. In practice, subband schemes can be used for wideband processing. However, this scheme is suboptimal since narrowband processing is done on each subband.

II. SUBBAND APPROACH

In the subband method, the received wideband data is expressed as sum of multiple narrowband signals as in (6). A bank of band-pass filters spanning the total signal bandwidth is used to divide the signal into sub-bands. If the bandwidth of the bank's filters is small enough then the sub-bands approximate narrowband signals and can be processed using narrowband STAP.

A typical filter bank is shown in Fig. 3 which uses least square approximate FIR low pass filters modulated to the center frequency of each frequency band. By modulating a low pass filter to a desired frequency, the passband of the filter includes desired frequencies.

The sampling frequency for the filter shown in Fig. 3 is 635MHz with 251 taps for each filter. A total of 10 filters within the filter bank spans 80MHz bandwidth is used. Each filter has a 3dB bandwidth of 8MHz. The center operating frequency of the array considered here is at 435MHz and 80MHz bandwidth corresponds to 18.4% Fig. 4 shows the structure of the subband method that use K beamformers.

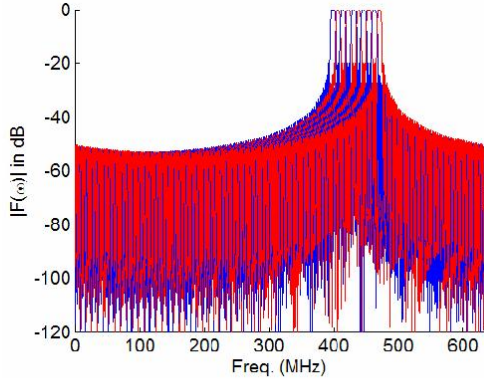

Fig. 3 Twenty sub-band least squares FIR filter bank ranging from 395MHz to 475MHz.

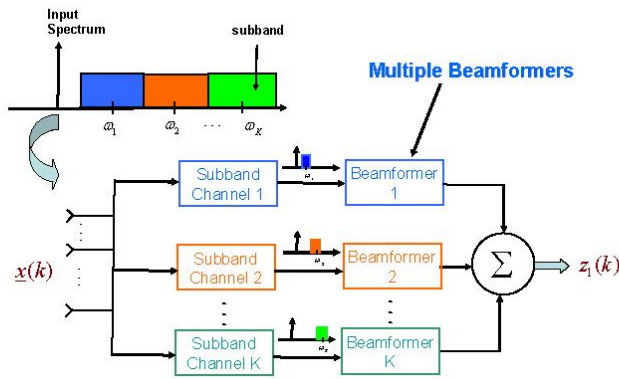

Fig. 4 Subband approach.

Fig. 5 shows the 4 frequency band outputs of the subband approach when 10 subbands are used. The sample matrix inversion with diagonal loading and subarray/subpulse smoothing (*SMIDLASAPFB*) technique is used here [3].

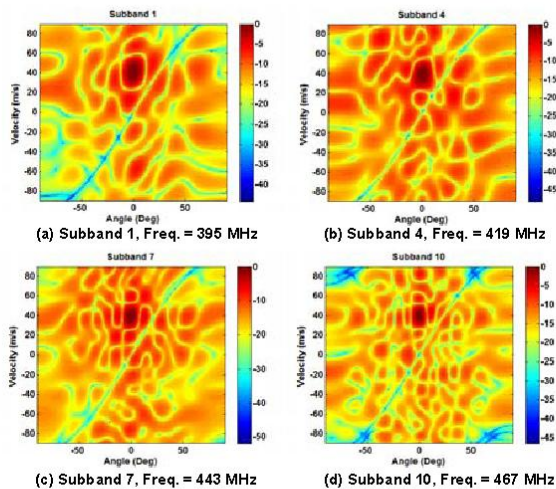

Fig. 5 Angle-Doppler output for different subbands.

Fig. 6 shows the average of the 10 subbands. A uniform array with 14 sensors and 16 pulses is considered here. The array interelement spacing is selected to be half wavelength at center frequency. The clutter to noise ratio and target to noise ratio are set at 40 dB and 0 dB respectively.

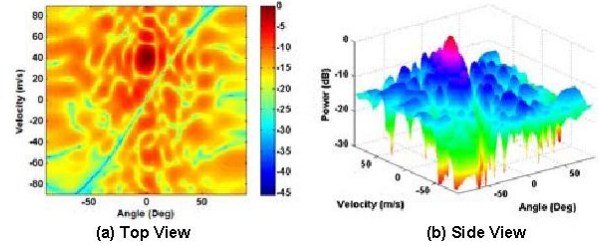

Fig. 6 Average Power Spectrum for 10 sub-bands processed with sample matrix inversion with diagonal loading and subarray/subpulse smoothing (*SMIDLASAPFB*).

III. MODULATION-SUM-FILTER APPROACH

This modulation-sum-filter method presented here for combining wideband data is in a sense equivalent to the focusing approach, although unlike the focusing method, there is no need to estimate the focusing matrices [4]. Instead, the multiple modulations are used to focus the wideband data into a narrow band region where they are summed and processed using narrowband STAP. This procedure is illustrated in Fig. 7 below.

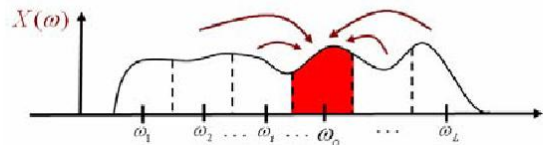

Fig. 7 Illustration of subbands being modulated to a common center frequency

By aligning the signals being added prior to band pass filtering, only one band pass filter is required. The signals are aligned by modulating each subband to the center frequency as shown in Fig. 8 where $X(\omega)$ is the Fourier transform of $x(t)$, $X_k(\omega)$ is the Fourier Transform of $x(t)$ modulated by $e^{j(\omega_o - \omega_k)t}$, and $H_{BF}(\omega)$ represents the bandpass filter.

The sum of the modulated signals can be expressed as the signal multiplied by a sum of modulating functions shifting each subband to the common center

$$y(t) = \sum_n x(t) e^{j(\omega_o - \omega_n)t} \leftrightarrow \sum_n X(\omega - \omega_o + \omega_n) = Y(\omega) \cdot (18)$$

This combined signal is finally bandpass filtered, effectively resulting in a single subband containing the averaged information of various subbands. Thus

$$Z(\omega) = H_{BF}(\omega)Y(\omega) \quad (19)$$

represents the filtered output. In the final step, traditional narrowband STAP processing can be applied to the filtered final output in (19).

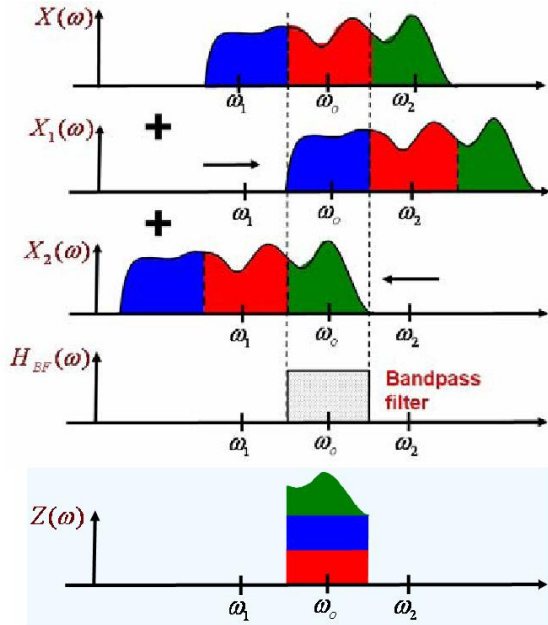

Fig. 8 Illustration of modulated versions of the same signal.

In practice, the total number of carrier frequencies being used and the bandwidth of the bandpass filter are free design parameters. In what follows, a set of simulation results are presented to exhibit the effects of these two parameters.

IV. SIMULATION RESULTS

Using the Modulation-Sum-Filter approach, a single target at θ_1 in the filtered data generates multiple target vectors corresponding to frequency $\omega_1, \omega_2, \dots, \omega_L$. Or equivalently, processing the data at ω_0 generates multiple targets at $\theta_1, \theta_2, \dots, \theta_L$ where

$$\omega_0 \sin \theta_1 = \omega_k \sin \theta_k, \quad k = 2, 3, \dots, L. \quad (20)$$

As a result, “Angle-Doppler spread” occurs in STAP output spectrum processed at a single frequency.

Fig. 9 shows the Angle-Doppler output using the Modulation-Sum-Filter approach. In Fig. 9, ten carriers are used for modulating the data to the center frequency 435 MHz. The combined data is then filtered with a single

bandpass filter with 8MHz bandwidth. The sample matrix inversion with diagonal loading and subarray/subpulse smoothing technique using 10 samples is shown here. Observe that the wideband target is clearly identified. However, the Angle-Doppler spread occurs as shown here where a single target with velocity = 40m/s appears as an “extended target” with different velocities.

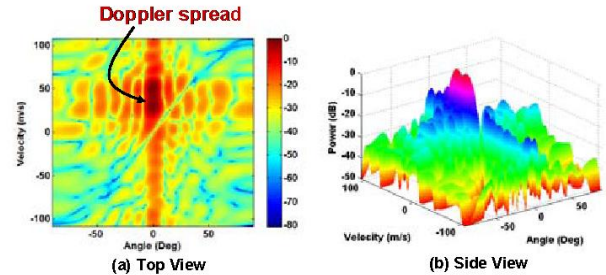

Fig. 9 Angle-Doppler spreading. Data is modulated by 10 carriers to 435MHz. Combined data is filtered with a bandpass filter with 8MHz bandwidth.

Fig. 10 shows the Angle-Doppler output using the Modulation-Sum-Filter approach using 20 modulations. The combined data is filtered using a bandpass filter with 4MHz bandwidth. Once again, the target is clearly identified and the Doppler spread present there is visible.

On comparing Fig. 10 with Fig. 9, the sidelobe level using 20 modulations is lower than that using 10 modulations. Thus the performance of the processing output using 20 modulations is superior to that using 10 modulations. In practice, the total number of carrier frequencies being used and the bandwidth of the bandpass filter need to be selected carefully to obtain optimum performance.

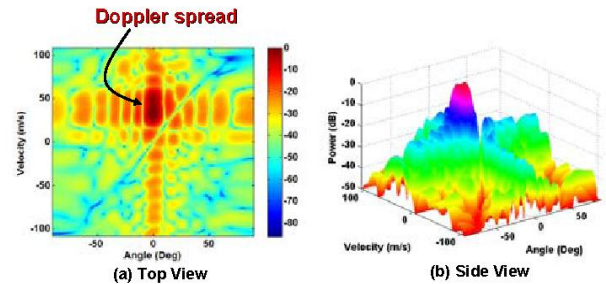

Fig. 10 Angle-Doppler spreading. Data is modulated by 20 carriers to 435MHz. Combined data is filtered with a bandpass filter with 4MHz bandwidth.

V. CONCLUSIONS

This paper presents a new method for processing wideband radar data. Instead of traditional subband processing, incoming wideband data signal is modulated by multiple carriers, combined, and filtered prior to processing using narrowband STAP. This method offers a significant

decrease in computations compared to the subband method. The detection performance is affected by free parameters such as the number of modulations used and the bandwidth of the filter. Using the Modulation-Sum-Filter approach, a single target in the filtered data generates multiple targets corresponding to different frequencies. As a result, "Angle-Doppler spread" occurs in STAP output spectrum processed at a single frequency. Methods to align the angle-Doppler spectrum need further study.

ACKNOWLEDGMENT

The research described herein is supported by the Air Force Research Laboratory (AFRL) Sensors Directorate, Radar Signal Processing Branch under USAF Contract FA8750-06-C-0117.

REFERENCES

- [1] T.C. Cheston and J. Frank, "Phase Array Radar Antenna", *Radar Handbook*, Chapter 7, McGraw Hill, New York 1990.
- [2] J. R. Guerci, *Space-Time Adaptive Processing for Radar*, Artech House, Boston, 2003
- [3] S. U. Pillai, K. Y. Li, B. Himed, *Space Based Radar – Theory & Applications*, McGraw Hill, NY, To be Published in Dec. 2007.
- [4] H. Hung, M. Kaveh. "Focusing Matrices for Coherent Signal-Subspace Processing." *IEEE Transactions on Acoustics, Speech, and Signal Processing*. Vol. 36, No. 8, August 1988.