

# Report Documentation Page

Form Approved  
OMB No. 0704-0188

Public reporting burden for the collection of information is estimated to average 1 hour per response, including the time for reviewing instructions, searching existing data sources, gathering and maintaining the data needed, and completing and reviewing the collection of information. Send comments regarding this burden estimate or any other aspect of this collection of information, including suggestions for reducing this burden, to Washington Headquarters Services, Directorate for Information Operations and Reports, 1215 Jefferson Davis Highway, Suite 1204, Arlington VA 22202-4302. Respondents should be aware that notwithstanding any other provision of law, no person shall be subject to a penalty for failing to comply with a collection of information if it does not display a currently valid OMB control number.

1. REPORT DATE <b>2008</b>		2. REPORT TYPE		3. DATES COVERED <b>00-00-2008 to 00-00-2008</b>	
4. TITLE AND SUBTITLE <b>Graded Bandgap Type-II Superlattice Photodiodes</b>				5a. CONTRACT NUMBER	
				5b. GRANT NUMBER	
				5c. PROGRAM ELEMENT NUMBER	
6. AUTHOR(S)				5d. PROJECT NUMBER	
				5e. TASK NUMBER	
				5f. WORK UNIT NUMBER	
7. PERFORMING ORGANIZATION NAME(S) AND ADDRESS(ES) <b>Naval Research Laboratory, 4555 Overlook Avenue SW, Washington, DC, 20375</b>				8. PERFORMING ORGANIZATION REPORT NUMBER	
9. SPONSORING/MONITORING AGENCY NAME(S) AND ADDRESS(ES)				10. SPONSOR/MONITOR'S ACRONYM(S)	
				11. SPONSOR/MONITOR'S REPORT NUMBER(S)	
12. DISTRIBUTION/AVAILABILITY STATEMENT <b>Approved for public release; distribution unlimited</b>					
13. SUPPLEMENTARY NOTES					
14. ABSTRACT					
15. SUBJECT TERMS					
16. SECURITY CLASSIFICATION OF:			17. LIMITATION OF ABSTRACT	18. NUMBER OF PAGES	19a. NAME OF RESPONSIBLE PERSON
a. REPORT <b>unclassified</b>	b. ABSTRACT <b>unclassified</b>	c. THIS PAGE <b>unclassified</b>			

## Graded Bandgap Type-II Superlattice Photodiodes

E.H. Aifer,<sup>1</sup> I. Vurgaftman,<sup>2</sup> C.L. Canedy,<sup>2</sup>  
E.M. Jackson,<sup>3</sup> J.G. Tischler,<sup>1</sup> J.H. Warner,<sup>1</sup> R. Stine,<sup>4</sup>  
J.R. Meyer,<sup>2</sup> and L.J. Whitman<sup>4</sup>

<sup>1</sup>*Electronics Science and Technology Division*

<sup>2</sup>*Optical Sciences Division*

<sup>3</sup>*SFA, Inc.*

<sup>4</sup>*Chemistry Division*

**Introduction:** An infrared focal plane array (IRFPA) is a dense array of sensors and readout circuitry that creates the image in an infrared camera. IRFPAs are at the core of infrared detector systems for finding and tracking missiles in space, guiding missile seekers, seeing in the dark, mapping ocean temperatures, and defeating camouflage and decoys. For the past decade, continuous improvement of IRFPAs based on mercury cadmium telluride have dramatically enhanced performance and expanded capabilities in the mid-wave (3–5  $\mu\text{m}$ ) and long-wave (8–14  $\mu\text{m}$ ) infrared (MWIR and LWIR) bands. However, further improvements demanded by the next generation of detector systems are driving investigations of other material systems.

A promising material system for the next generation of IRFPAs is the type-II superlattice (T2SL) lattice-matched to GaSb. Although the T2SL detector concept was proposed over 30 years ago,<sup>1</sup> only in the last few years has this design begun to demonstrate its potential. NRL researchers have been at the forefront, making key innovations including the W-structured T2SL (WSL), the graded bandgap T2SL photodiode,<sup>2</sup> and most recently, shallow-etch mesa isolation.

**T2SL Photodiodes:** The simplest form of T2SL, illustrated in Fig. 3(a), consists of alternating layers of GaSb and InAs. The type-II nature of the band alignment is evident in the relative position of the InAs conduction band (CB), which is lower in energy than the GaSb valence band (VB). In a short-period superlattice, however, the energy levels in each layer are shifted by quantum confinement, with the electron levels moving up and the hole levels moving down, opening up a positive energy gap as indicated by the carrier positions. There are several advantages in using the T2SL for infrared detection. First, one can conveniently adjust the energy gap over a very wide range (3–30  $\mu\text{m}$ ) by varying the layer thicknesses. Second, the electron effective mass is heavier than in the bulk material (and about three times larger than that of mercury cadmium telluride). The heavier mass strongly suppresses dark-current caused by tunneling between the conduction and valence bands. Finally, a gap opens in

the superlattice band structure between the light-hole (L1) and heavy-hole (H1) bands, and this gap can be engineered to reduce Auger processes, thereby increasing the operating temperature range of the device.

An important NRL innovation was to adapt the WSL—originally developed at NRL for MWIR laser applications—for use in photodiodes. The more complex WSL structure, shown in Fig. 3(b), includes a second InAs layer that makes the electron wavefunction symmetric about the hole states, and adds AlGaInSb barriers that more strongly confine the wavefunctions (without completely localizing them). This structure results in a four-fold increase in electron mass over the basic T2SL, and a nearly two-dimensional bandstructure that strongly enhances optical absorption near the band edge.

**Graded Bandgap WSL:** Although the dark-current performance of T2SL-based photodiodes improved with the WSL design, it was still limited by defect-mediated processes such as trap-assisted tunneling and excess generation-recombination. We achieved a major breakthrough in controlling these processes with the graded bandgap WSL, illustrated in red in Fig. 4(a). In this structure, the band edges are smoothly graded in the vicinity of the junction, increasing from the narrow-gap IR absorbing layer to the much wider-gap n+-doped superlattice that forms the cathode. The band profile is carefully shaped to form a very large tunneling barrier, and to suppress generation-recombination current. The key to realizing this structure is the flexibility afforded by the WSL, which allows independent control of the band edges while maintaining a good lattice match to the substrate. For comparison, the band edges of a uniform (ungraded) diode with the same bandgap are shown in Fig. 4(a) in blue. The dark-current performance of the two structures is displayed in Fig. 4(b), with the graded structure (GGW) having a dark-current >100 times lower at 60 K and >10 times lower at 80 K.

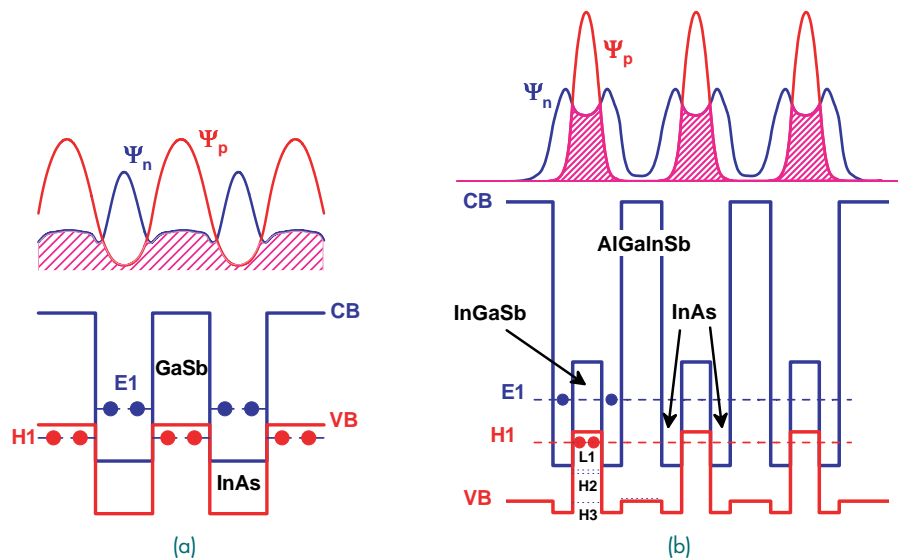
**Shallow-Etch Mesa Isolation:** In a LWIR focal plane array, typically made with pixels 20 to 40  $\mu\text{m}$  wide isolated by deep trenches, the limiting factor in dark-current performance is often surface recombination and leakage involving defect states on mesa sidewalls. However, surface leakage is readily controlled in MWIR T2SL photodiodes, to the extent that commercially produced FPAs are presently available. In this context, bandgap grading leads to a powerful means to addressing surface leakage. The solution, illustrated in Fig. 5, is to fabricate mesa diodes on graded-bandgap structures with LWIR and very long wave infrared (VLWIR) absorbers such that only wider-gap (MWIR) layers are exposed on the surface, greatly simplifying

passivation. We have thus developed the technique of shallow-etch mesa isolation (SEMI) employing two separate etch steps on graded-gap T2SL photodiodes. First a shallow etch is used to electrically isolate neighboring pixels, terminating just past the junction but well within the MWIR-gap region of the diode. A deep etch is then performed along the periphery of the array to allow contact to the backside anode. The LWIR or VLWIR layers remain undisturbed and protected by at least 100 nm of material, and the entire pixel is optically functional. Using SEMI, we have been able to achieve bulk-limited performance on pixels with mesa diameters as small as 24  $\mu\text{m}$ . Furthermore, the electrical junction area can be reduced to a fraction of the pixel area without loss of quantum efficiency, provided the junction is within a lateral diffusion length of the pixel border (10–15  $\mu\text{m}$ ). Using this approach, we have achieved a factor of three reduction in bulk junction current.

[Sponsored by NRL]

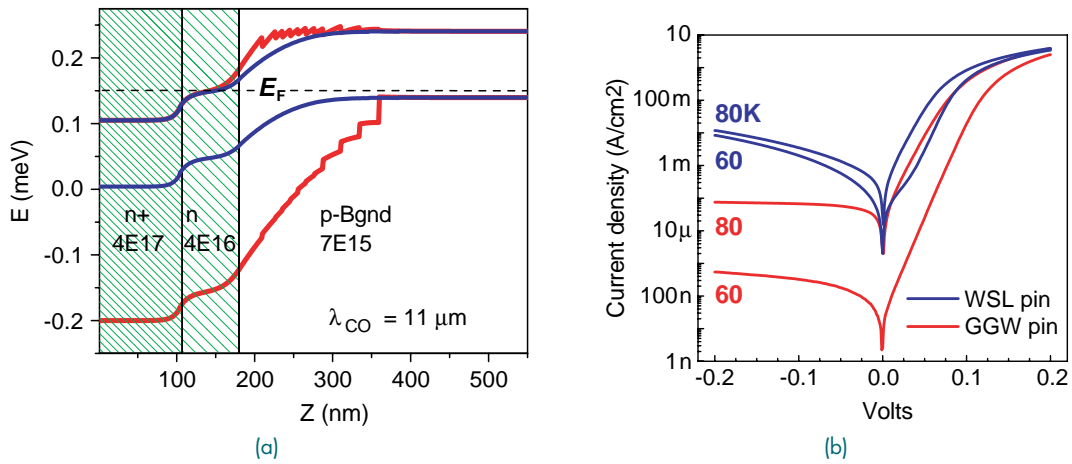
#### References

- <sup>1</sup>G.A. Sai-Halasz, R. Tsu, and L. Esaki, "A New Semiconductor Superlattice," *Appl. Phys. Lett.* **30**, 651 (1977).
- <sup>2</sup>I. Vurgaftman, E.H. Aifer, C.L. Canedy, J.G. Tischler, J.R. Meyer, J.H. Warner, E.M. Jackson, G. Hildebrandt, and G.J. Sullivan, "Graded Band Gap for Dark-Current Suppression in Long-Wave Infrared W-Structured Type-II Superlattice Photodiodes," *Appl. Phys. Lett.* **89**, 121114 (2006). ★

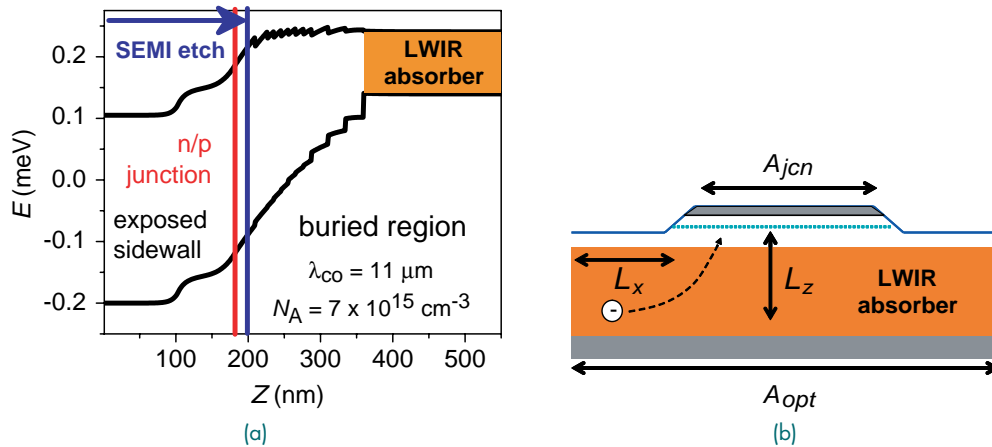


**FIGURE 3**

(a) Simple T2SL and (b) WSL heterostructures and wavefunctions.



**FIGURE 4** Comparison of graded bandgap (red) and uniform WSL (blue) photodiode: (a) bandstructure; (b) current-voltage characteristics.



**FIGURE 5** SEMI process for graded bandgap T2SL photodiodes: (a) bandstructure; (b) schematic of photodiode cross-section.  $A_{jcn}$  = junction area;  $A_{opt}$  = optical area;  $L_x$  = lateral diffusion length;  $L_z$  = vertical diffusion length.