

RESSOX CONTROL OF QZSS DURING COMMUNICATION INTERRUPTION

Toshiaki Iwata, Takashi Matsuzawa

National Institute of Advanced Industrial Science and Technology (AIST)

1-1-1 Umezono, Tsukuba Central 2, Tsukuba, Ibaraki 305-8568, Japan

Tel: +81-29-861-5706, Fax: +81-29-861-5709

E-mail: totty.iwata@aist.go.jp

Akiyoshi Abei

Cosmo Research Corporation, Japan

Abstract

The Remote Synchronization System for the Onboard Crystal Oscillator (RESSOX) is a new timekeeping method for the Japanese Quasi-Zenith Satellite System (QZSS), and a remote synchronization system for the onboard crystal oscillator of a satellite and the atomic clock of the ground station. RESSOX is developed with an eye to replacing the onboard atomic clock. One of the serious problems of RESSOX is that the QZSS must have an approximately 35-minute communication interruption twice a day to avoid interfering with the communication of other geostationary satellites when the QZS crosses the equator. During the communication interruption, the onboard crystal oscillator will be controlled, not by RESSOX, but by an onboard local system. Two control algorithms were proposed: (1) the averaging of adjacent voltage data and (2) the first-order extrapolation of adjacent voltage data prior to communication interruption. As the behavior of the crystal oscillator is statistical, we attempted to apply a statistical method using our RESSOX hardware/software simulators for the evaluation. At least 12 experiments/simulations were conducted for each case. The standard deviations of the maximum synchronization errors during the 35-minute communication interruption between the onboard crystal oscillator of the satellite and the atomic clock of the ground station were compared. The results of simulations and experiments correspond to each other. In general, the results obtained by averaging show better synchronization than those obtained by first-order extrapolation. The best result was given by the case of averaging 100 adjacent voltage data, and the standard deviation of the maximum synchronization error was 2.80 ns.

I. INTRODUCTION

The quasi-zenith satellite system (QZSS) has been under development as a Japanese space project since 2003, and its mission is navigation and/or positioning [1]. Its constellation consists of three satellites orbiting on inclined orbital planes with a geosynchronous period. The first QZS will be launched in the summer of 2010. The QZSS utilizes a highly inclined orbit to ensure high visibility over high-latitude regions. In the case of the QZSS, at least one satellite is highly visible near the zenith at any time from Japan. Therefore, users in Japan can always receive navigation signals from at least one of the QZSSs near the zenith.

Report Documentation Page

Form Approved
OMB No. 0704-0188

Public reporting burden for the collection of information is estimated to average 1 hour per response, including the time for reviewing instructions, searching existing data sources, gathering and maintaining the data needed, and completing and reviewing the collection of information. Send comments regarding this burden estimate or any other aspect of this collection of information, including suggestions for reducing this burden, to Washington Headquarters Services, Directorate for Information Operations and Reports, 1215 Jefferson Davis Highway, Suite 1204, Arlington VA 22202-4302. Respondents should be aware that notwithstanding any other provision of law, no person shall be subject to a penalty for failing to comply with a collection of information if it does not display a currently valid OMB control number.

1. REPORT DATE NOV 2009		2. REPORT TYPE		3. DATES COVERED 00-00-2009 to 00-00-2009	
4. TITLE AND SUBTITLE Ressox Control of QZSS During Communication Interruption				5a. CONTRACT NUMBER	
				5b. GRANT NUMBER	
				5c. PROGRAM ELEMENT NUMBER	
6. AUTHOR(S)				5d. PROJECT NUMBER	
				5e. TASK NUMBER	
				5f. WORK UNIT NUMBER	
7. PERFORMING ORGANIZATION NAME(S) AND ADDRESS(ES) National Institute of Advanced Industrial Science and Technology (AIST),1-1-1 Umezono, Tsukuba Central 2,Tsukuba, Ibaraki 305-8568, Japan,				8. PERFORMING ORGANIZATION REPORT NUMBER	
9. SPONSORING/MONITORING AGENCY NAME(S) AND ADDRESS(ES)				10. SPONSOR/MONITOR'S ACRONYM(S)	
				11. SPONSOR/MONITOR'S REPORT NUMBER(S)	
12. DISTRIBUTION/AVAILABILITY STATEMENT Approved for public release; distribution unlimited					
13. SUPPLEMENTARY NOTES 41st Annual Precise Time and Time Interval (PTTI) Systems and Applications Meeting, 16-19 Nov 2009, Santa Ana Pueblo, NM					
14. ABSTRACT see report					
15. SUBJECT TERMS					
16. SECURITY CLASSIFICATION OF:			17. LIMITATION OF ABSTRACT	18. NUMBER OF PAGES	19a. NAME OF RESPONSIBLE PERSON
a. REPORT unclassified	b. ABSTRACT unclassified	c. THIS PAGE unclassified			

In general, global navigation satellite systems (GNSSs), such as the GPS of the US, GLONASS of Russia, and GALILEO of Europe, are equipped with onboard atomic frequency standards that are used as time references. This is because (1) atomic clocks have good long-term stability, (2) the orbit of the satellites makes monitoring from one ground station impossible, (3) these satellite systems are used for military missions and are, therefore, expected to operate even if ground stations are destroyed, and (4) these systems consist of many satellites, making the control of each satellite with many antennae difficult. However, onboard atomic clocks have the following disadvantages: they are bulky, expensive to manufacture and launch, power-demanding, and sensitive to temperature and magnetic fields. Moreover, they are one of the main contributors to the reduction of satellite lifetime.

The following have been taken into consideration in the design of the QZSS as a civilian navigation system: (1) some crystal oscillators have better short-term stability than atomic clocks [2], (2) 24-hour control from one station is possible if the location of the control station is appropriate, for example, Okinawa, Japan, and (3) the number of satellites is assumed to be only three. Given these considerations, the remote synchronization system for the onboard crystal oscillator (RESSOX), which does not require onboard atomic clocks, has been developed. In the case of RESSOX, modification of the control algorithm after launch is easy because it is basically a ground technology. The target synchronization accuracy of RESSOX is set at 10 ns and the target stability is 1×10^{-13} at 100,000 s. These targets were determined on the basis of the synchronization performance between GPS time and UTC (USNO) [3] and the long-term stability performance of onboard cesium atomic clocks [4].

RESSOX ground experiments and computer simulations have been conducted since 2003. Preliminary experimental results obtained using navigation signals are detailed in our previous papers [5-8]. We have developed a feedback method that uses multiple navigation signals of the QZSS, and found that we do not need precise orbit information or estimation of delays, such as those caused by the ionosphere and the troposphere, to realize RESSOX technology.

In actual QZSS operation, 35-minute communication interruption (CI) above the equator occurs twice a day because of the need to avoid interference with other geostationary earth orbit (GEO) satellites. For RESSOX, the control method of the crystal oscillator during CI is an issue to be resolved, and is described in detail in this paper.

In a practical sense, two rubidium atomic standards will be loaded on the QZSS. RESSOX is tested in experiments to examine its use in future QZSSs.

II. RESSOX OVERVIEW AND CONTROL DURING CI

Figure 1 shows the schematic of RESSOX. In order to realize RESSOX, it is indispensable to identify the error factors and the feedback mechanism by measuring the delay at the ground station. The former is related to the estimation of error and delay using models, and is considered to be a feed-forward loop. The RESSOX control signal includes time information of the ground atomic clock, and is advanced to compensate the transmission delay. Therefore, the RESSOX control signal is synchronized with the ground atomic clock when it arrives at the QZS.

The latter is an error adjustment system that uses pseudoranges measured with the QZS signals (navigation signals) of the QZSS and estimated pseudoranges, and is considered to be a feedback control.

The error and delay models in the feed-forward loop are delays in the ground station and in the satellite,

tropospheric delay, ionospheric delay, delay due to distance (orbit estimation), delay due to relativity effects, and errors caused by Earth's motion, such as daily rotation, nutation, and precession. These problems were discussed in our previous paper [5]. However, if multiple navigation signals are used for feedback, use of the delay models becomes unnecessary [7, 8].

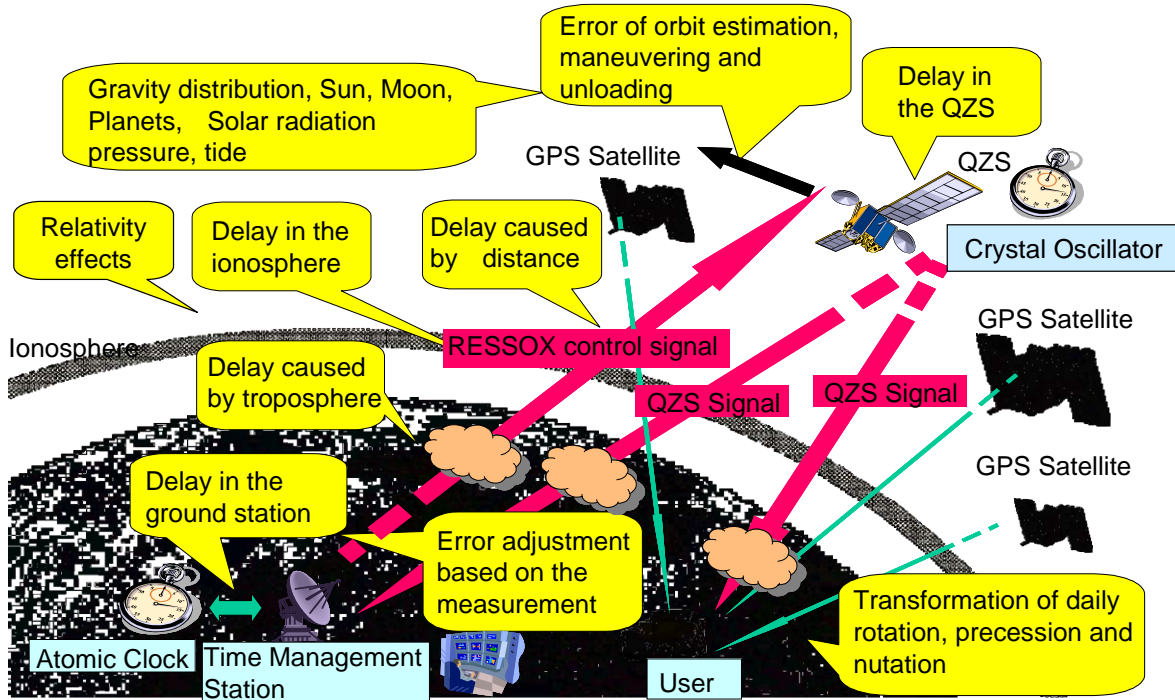

Fig. 1. RESSOX schematic.

When CI occurs, the applied voltage data immediately before the CI are used to control the onboard crystal oscillator. Two strategies are prepared: simple averaging and first-order extrapolation. The number of voltage data used is changed from 50 to 100, 200, 300, 500, and 1000 (the voltages are applied every 1.5 s) and evaluated in this study, although the number in actual operation will be limited to 100 and 200. Figure 2 shows the schematic of the control method.

III. COMPUTER SIMULATION OF RESSOX BEHAVIOR DURING CI SIMULATION METHOD

Figure 3 shows the block diagram of the computer simulation. First, the onboard crystal oscillator is modelled. The pure crystal oscillator outputs 10.23 MHz when the control voltage is 5.4 V, and the frequency increases by 0.33 Hz when the control voltage increases by 1 V. The output frequency of the crystal oscillator is formulated as follows:

$$f_c = 1.023 \times 10^7 + 0.33(V - 5.4) \text{ [Hz]}. \quad (1)$$

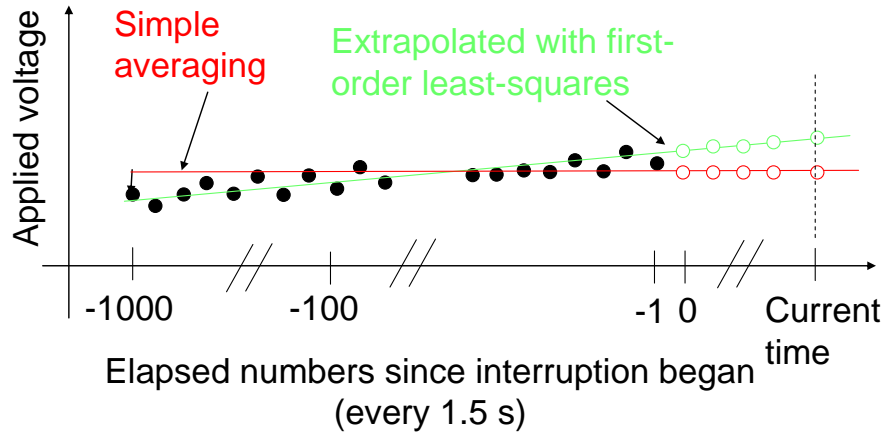

Fig. 2. Schematic of the control method.

The pure time standard model outputs the frequency as $f_s = 1.023 \times 10^7$ Hz.

The n-th time difference result Δt_n of pure Time Comparison Unit (TCU) is modelled as follows:

$$\Delta t_n = \Delta t_{n-1} + 1.5 \times \frac{f_s - f_c}{f_s} \text{ [s]}. \quad (2)$$

This is because the time difference is measured every 1.5 s.

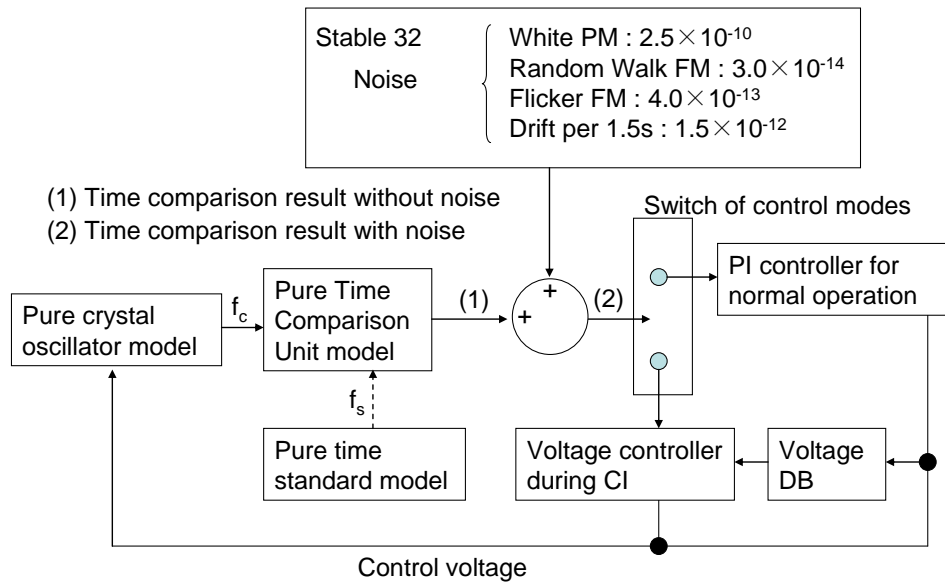

Fig. 3. Block diagram of computer simulation.

The actual crystal oscillator, the time standard, and the TCU generate noise. To formulate the noise model, the Allan deviation of the crystal oscillator used in the experiment is measured. The result is

shown in Fig. 4 with a blue line. Using Stable 32 software that generates various noises and simulates the behavior of the crystal oscillator, the crystal oscillator is modelled as follows: Random Walk FM is 3.0×10^{-14} , Flicker FM is 4.0×10^{-13} , White PM is 4.0×10^{-13} , and Drift per 1.5 s is 1.5×10^{-12} , and the result is shown in Fig. 4 with a pink line. The TCU will have 0.16 ns white PM noise every 1.5 s (White PM is 2.5×10^{-10}). Finally, the total noise model including TCU is as follows: Walk FM is 3.0×10^{-14} , Flicker FM is 4.0×10^{-13} , White PM is 2.5×10^{-10} , and Drift per 1.5 s is 1.5×10^{-12} . The result is shown in Fig. 4 with a red line. Using these noise data, computer simulation is conducted.

In normal operation, modified PI control is used for the crystal oscillator. The following formula describing PI control is used.

$$v_k = offset - \frac{k_1}{l+1} \sum_{i=k-l}^k \Delta t_i - k_2 \sum_{i=0}^{k-1} \int^{i+p} \Delta t dt, \quad (3)$$

where v_k is the k -th applied voltage, $offset = 5.4$ (V), k_1 is a proportional gain set at 7.0×10^5 , k_2 is an integral gain set at 3.0×10^3 , l is the number of past data used for proportional control set at 1, k is data number from the beginning, p is the integral interval, which means an overlapping integral number, set at 2, and Δt is the time difference measured by TCU. During PI control, applied voltage data output by the PI controller are accumulated and a database named Voltage DB is constructed.

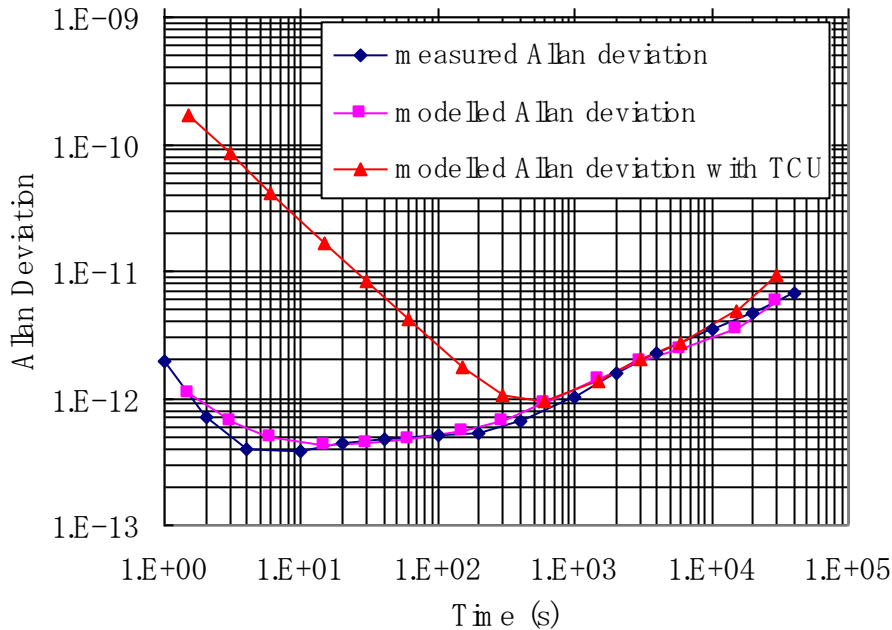

Fig. 4. Allan deviations of actual crystal oscillator, modelled crystal oscillator, and modelled TCU output.

SIMULATION RESULTS

In the computer simulation, 50-minute PI control is first conducted, and this is followed by 35-minute CI control. As a result, one simulation is completed in 85 minutes. The initial synchronization error is 1 μ s. In the case of CI, the applied voltages are determined as shown in Fig. 2 using Voltage DB. The

simulation is conducted twelve times for each case. Figure 5 shows the simulation results obtained by averaging 50, 100, 200, 300, 500, and 1000 applied voltage data, and Fig. 6 shows the simulation results obtained by first-order extrapolation of 50, 100, 200, 300, 500, and 1000 applied voltage data. In the figures, CI control begins from the elapsed time of 3000 s. Pink lines show the simulation results of the maximum synchronization errors and blue lines show those of the minimum synchronization errors.

In the case of averaging of the applied voltage data, no explicit difference is observed among the results.

In the case of first-order extrapolation of the applied voltage data, the larger the number of applied voltage data is, the smaller the synchronization errors are.

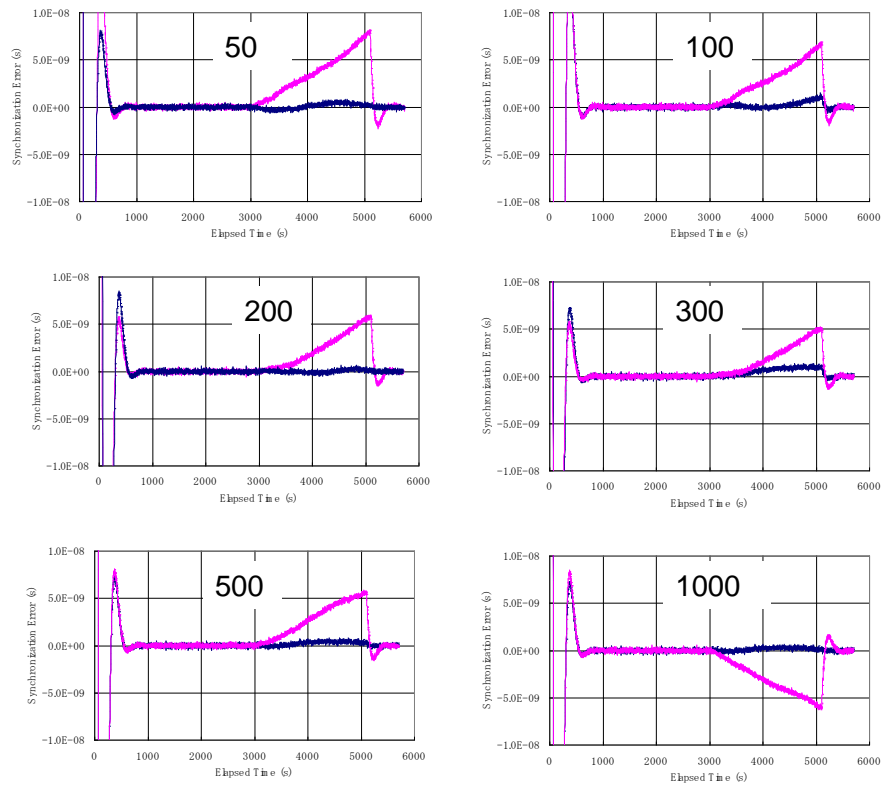

Fig. 5. Simulation results obtained by averaging 50, 100, 200, 300, 500, and 1000 applied voltage data.

As the behavior of the crystal oscillator is statistical, the discussion of the maximum or minimum synchronization error is insufficient. Therefore, statistical evaluation is conducted. Standard deviations of the maximum synchronization errors are evaluated and the results are shown in Fig. 7. The worst result is the case of the first-order extrapolation of 50 applied voltage data, where the standard deviation is 54.7 ns, and the best result is the case of averaging 100 or 200 applied voltage data, where the standard deviation is 3.29 ns. The best result in the first-order extrapolation cases is the case that uses 1000 applied voltage data, where the standard deviation is 5.37 ns. However, this result is worse than the case of averaging 1000 applied voltage data, where the standard deviation is 4.43 ns.

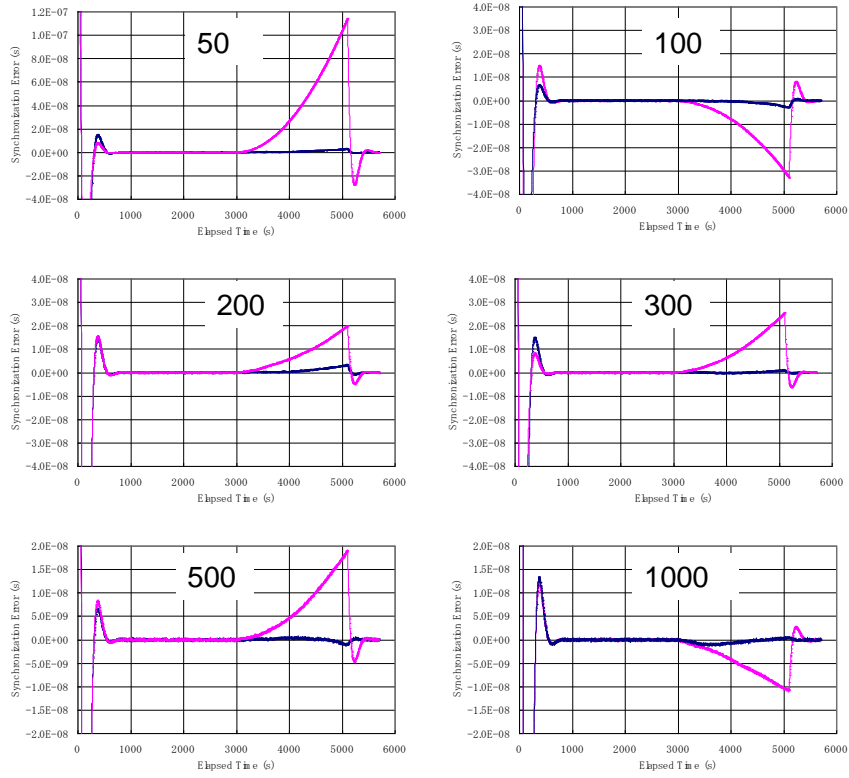

Fig. 6. Simulation results obtained by first-order extrapolation of 50, 100, 200, 300, 500, and 1000 applied voltage data.

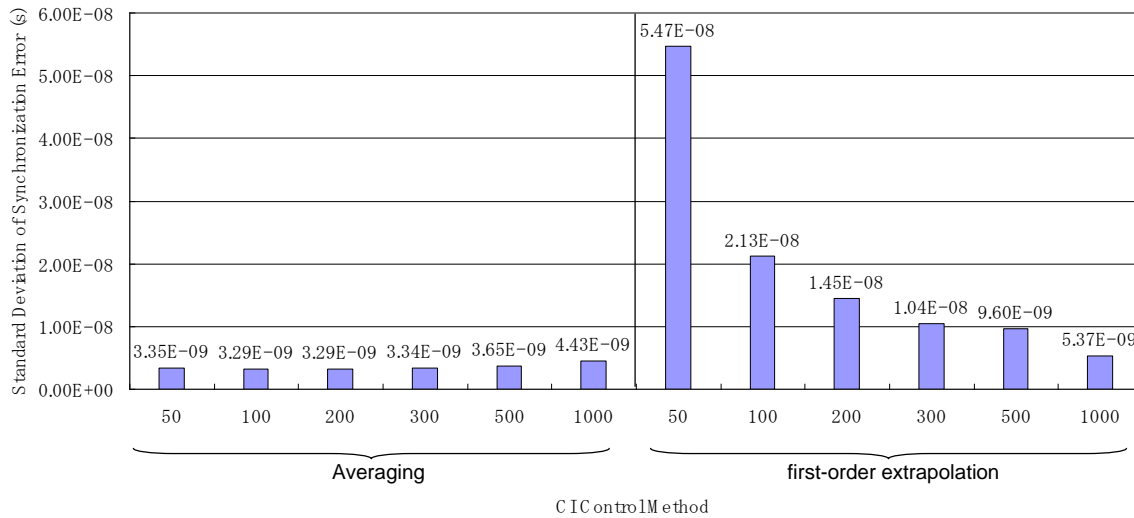

Fig. 7. Standard deviations of maximum synchronization errors (simulation).

IV. GROUND EXPERIMENTS OF RESSOX BEHAVIOR DURING CI

EXPERIMENTAL METHOD

Experiments using the ground confirmation test apparatuses are also conducted. Two kinds of experiments are executed: (1) basic experiments and (2) actual operation experiments. The details of the experimental conditions will be explained later. Figure 8 shows the block diagram of the experimental apparatuses. Each apparatus has been introduced in detail in reference [9] and only a brief introduction is provided here. A RESSOX control signal transmitter (RCST) that advances the time information to compensate the transmission delay, a QZSS/GPS receiver (QZSSREC) that measures the pseudoranges of the navigation signals, a RESSOX controller (RC) comprising a PC using Windows XP, and a frequency transformer (FT) that supplies 10.23 MHz and 1.5 s pulses are provided as ground station equipment. As a reference clock, a hydrogen maser (H-Maser) is used. An uplink delay simulator (UDS2), an engineering model of the onboard crystal oscillator (MINI-OCXO), a simulator of the onboard time comparison unit (TCUSIM), a simulator of the navigation onboard computer (NOCSIM), a D/A converter, a QZSS simulator (QSIM2) that provides navigation signals with transmission delay using SimQZ software, and a pulse generator (PG) that supplies 1 s and 1.5 s pulses are also provided to confirm the operation of the ground station apparatuses. A time-interval counter (TIC) measures the time difference between H-Maser and MINI-OCXO.

BASIC EXPERIMENTS

In the basic experiments, the pseudorange or the assumed distance between the QZSS and the ground station is constant at 250 km. The reason why the distance is 250 km is as follows. Because L1C/A navigation messages of constant distance cannot be prepared, navigation messages are not used for ambiguity resolution. As the ambiguity of L1C/A is 300 km, the distance should be less than 300 km and therefore, 250 km is selected. The measured error of pseudorange is assumed to be +5 m, so that the feedback command is 5 m. In the experiments, 55-minute PI control is first conducted, and this is followed by 35-minute CI control. As a result, one simulation is completed in 90 minutes. The numbers of times of each experiment are shown in Table 1.

The results of basic experiments correspond to the simulation results. Figures 9 and 10 show respectively the results of the averaging and the first-order extrapolation of 50, 100, 200, 300, 500, and 1000 applied voltage data. Most of the results are similar to the simulation results.

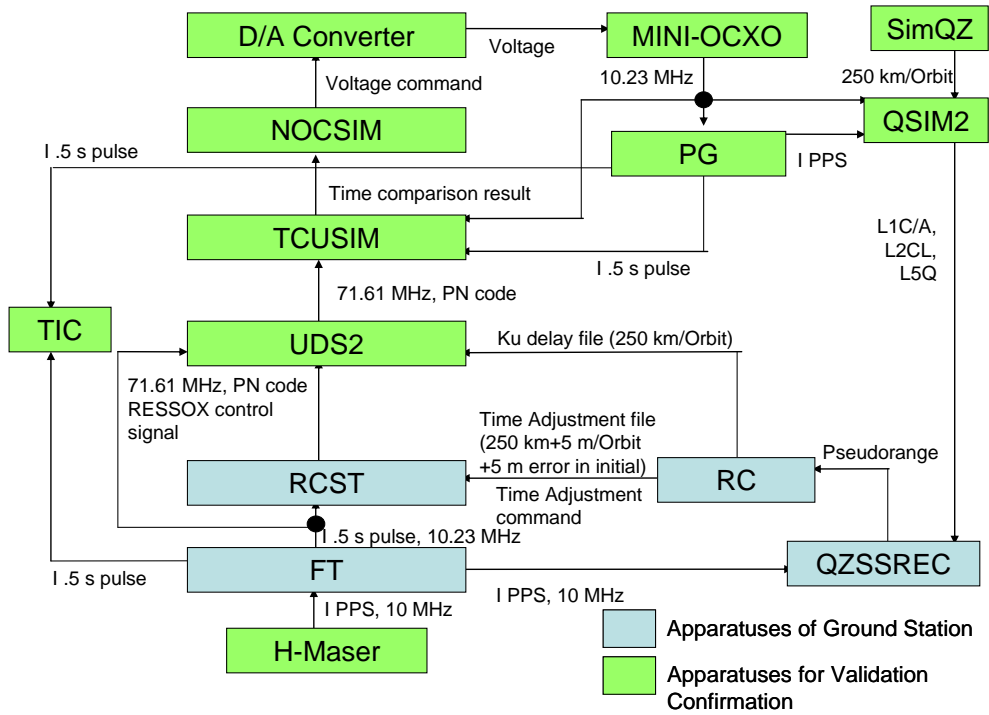

Fig. 8. Block diagram of experimental apparatuses.

Table 1. Numbers of times of each experiment.

# of used data	Averaging	First –order extrapolation
50	16	32
100	72	56
200	53	66
300	16	48
500	16	41
1000	16	27

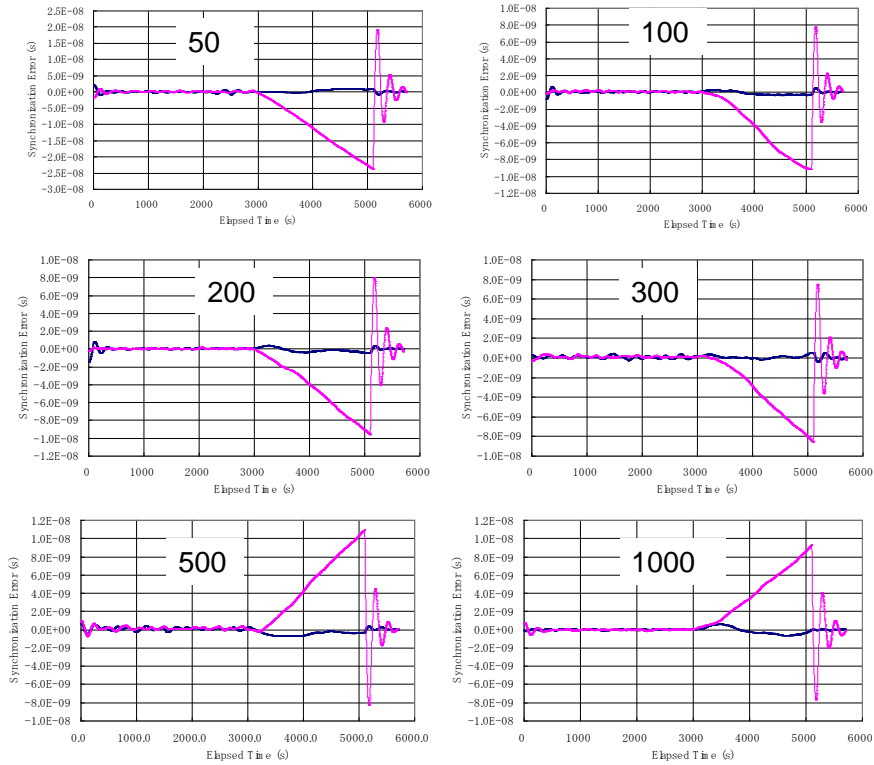

Fig. 9. Basic experimental results obtained by averaging 50, 100, 200, 300, 500, and 1000 applied voltage data.

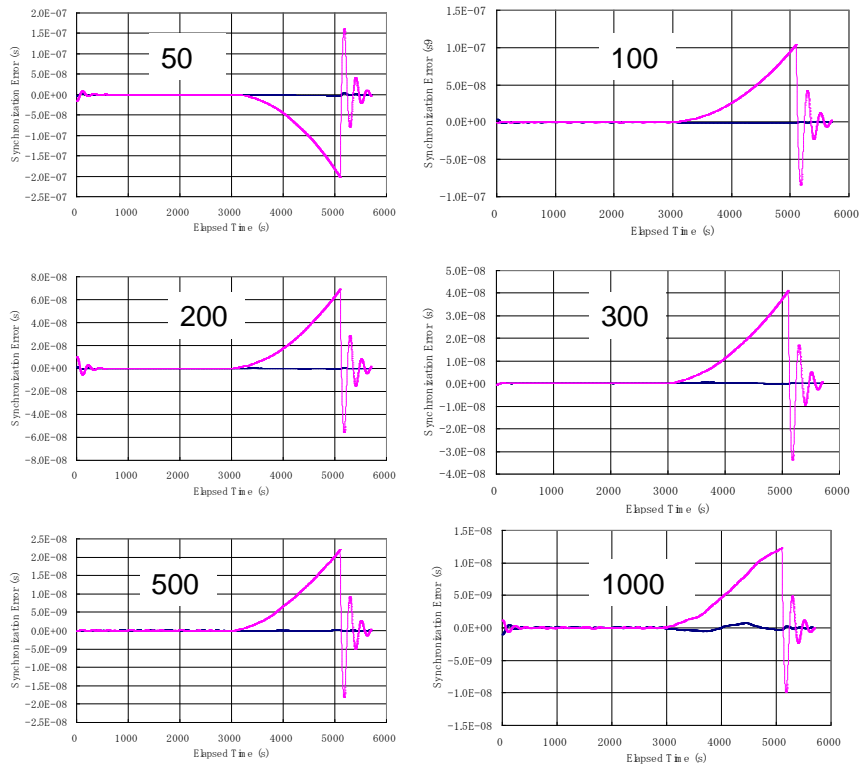

Fig. 10. Basic experimental results obtained by first-order extrapolation of 50, 100, 200, 300, 500, and 1000 applied voltage data.

Figure 11 shows the standard deviations of the experiments. The worst result is the case of the first-order extrapolation of 50 applied voltage data, where the standard deviation is 78.5 ns, and the best result is the case of averaging 100 applied voltage data, where the standard deviation is 2.80 ns. The best result of the first-order extrapolation cases is the case that uses 1000 applied voltage data, where the standard deviation is 5.81 ns. These results are also similar to the simulation results.

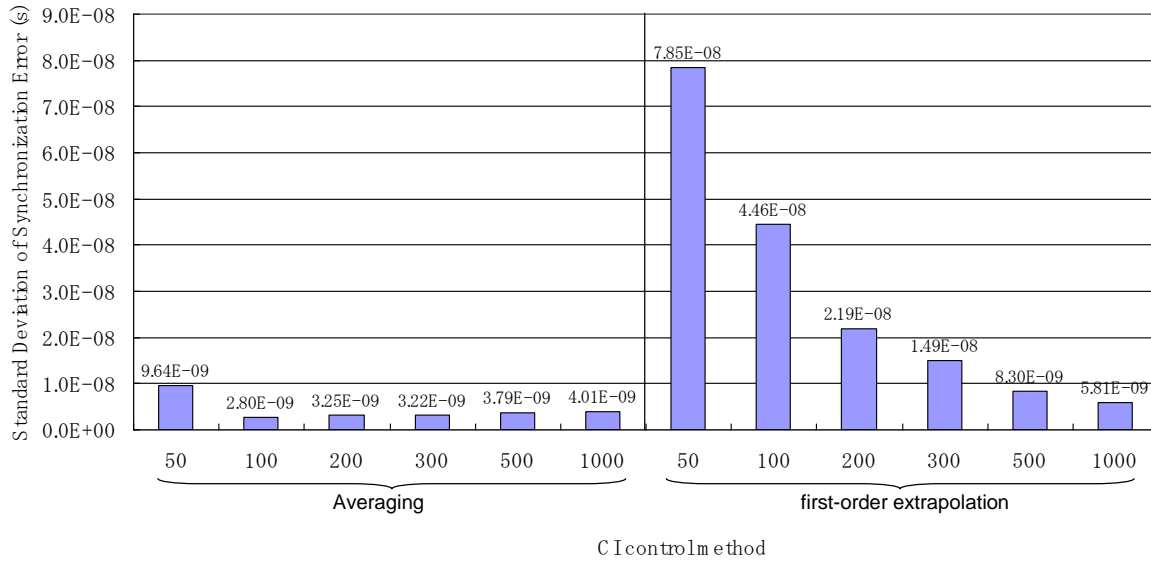

Fig. 11. Standard deviations of maximum synchronization errors (basic experiments).

ACTUAL OPERATION EXPERIMENT

In the actual operation experiment, 24-hour operation is tested and the pseudorange or the assumed distance between the QZSS and the ground station is changed according to the motion of the QZS. The method employed in the actual operation experiment is described in detail in reference [10] and only a brief explanation is provided here.

Table 2 shows the experimental conditions. No error condition is used for the delay of UDS2 and QSIM2, which simulates real delays. The error condition is used for the delay of RCST and QZSSREC, which is assumed to be obtained at the ground station based on measurements. As the errors, we provide satellite position estimation error (+5 m error for each coordinate), and ionospheric and tropospheric delay and relativity effects are not taken into consideration.

In this experiment, three navigation signals, L1C/A, L2CL, and L5Q, are used for the feedback control. The number of samples to be adjusted, which is used to calculate the time adjustment command, is 100. Two 35-minute CIs above the equator are assumed during 24-hour operation and the averaging of 100 applied voltage data is used.

The results are shown in Figs. 12 and 13. The QZS is located in the Northern Hemisphere until 10:00. In this part, navigation signal noise is small, so that the phase noise of the synchronization error is also small. This affects MINI-OCXO control voltage stability and the synchronization error during CI is 2 ns. On the other hand, the QZS is located in the Southern Hemisphere from 11:00 to 21:00. In this part, navigation signal noise is substantial due to weak signals, so that the phase noise of the synchronization error is also substantial. This affects the control voltage stability and the maximum synchronization error

during CI is 6 ns.

Table 2. Experimental conditions.

Condition of orbit and delay calculation	No error (for UDS2 and QSIM2)	Error (for RCST and QZSSREC)
Initial condition of orbit calculation (ICRF)	x = -23342012.770 m y = -33282936.570 m z = 15995302.769 m vx = 2184.551 m/s vy = -935.546 m/s vz = 1774.093 m/s	x = -23342007.770 m y = -33282931.570 m z = 15995307.7695 m vx = 2184.551 m/s vy = -935.546 m/s vz = 1774.093 m/s
Gravity potential model	EGM96, 360 degree, 360 order	
Other bodies	Moon, Sun, Mercury, Venus, Mars, Jupiter, Saturn, Uranus, Neptune, Pluto	
Solar radiation pressure model	Cr model, Cr=1.2, 30 m ²	
Solid tide effect	Considered	
Satellite mass	1816 kg	
Ionospheric delay	CODE data are used	Not considered
Tropospheric delay	Saasamoinen, temperature 15 °C, pressure 1013.25 hPa, humidity 70%	Not considered
Relativity effect	Considered	Not considered
Simulation period	1999/12/31 23:59:47 - 2000/01/01 23:59:47	
Observed position	Okinawa 26.5 N, 127.9 E, 0.0 m geodetic height)	

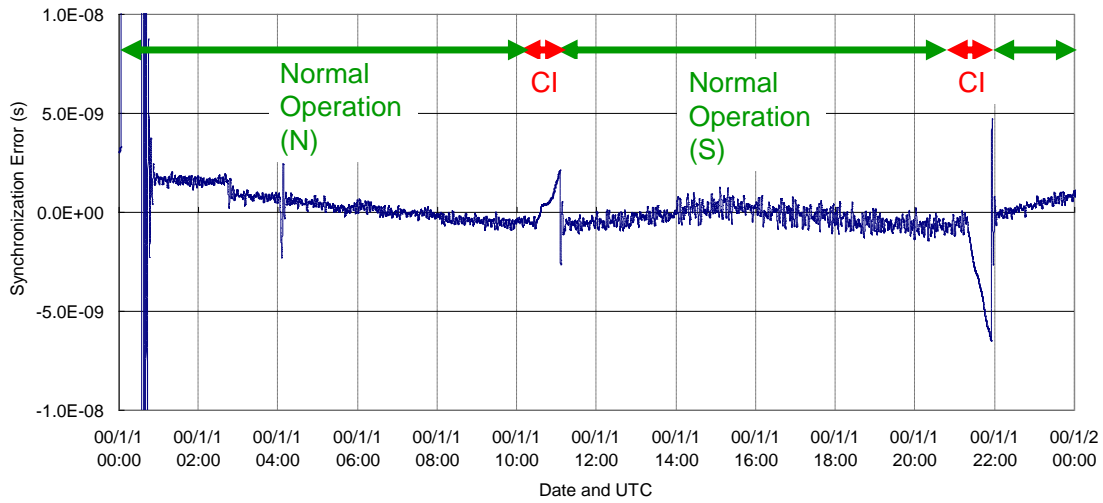

Fig. 12. Result of actual operation experiment (synchronization error).

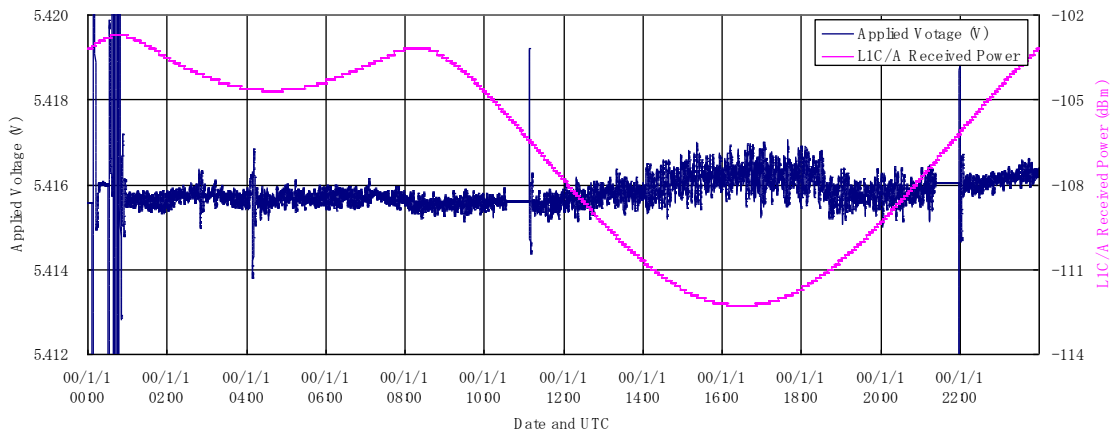

Fig. 13. Result of actual operation experiment (applied voltage and signal power).

V. DISCUSSION

CONTROL RESOLUTION AND ERROR ORIGIN

In the experiments, the applied voltage ranging from 0 to 10 V is controlled by a 24-bit D/A converter. This means that the smallest resolution of the applied voltage is 59.6 nV, and based on the MINI-OCXO model, equation (1) shows that the frequency rate is 0.33 Hz/V, which means 33 ns/V per second. If the applied voltage command has an error of 1-bit D/A converter, that is, 59.6 nV, the synchronization error increases by 2×10^{-6} ns every second and becomes 4.2 ps after 35 minutes. This means that the resolution of the D/A converter hardly affects the synchronization error.

In the typical case of the basic experiments using PI control, the applied voltage has the following statistical values: the average is 5.379960109 V and the standard deviation is 3.9101×10^{-5} V. If we consider the worst case, namely, the error of the applied voltage is $3\sigma = 117.303 \mu\text{V}$, the error after 35 minutes is 8.1 ns if a constant voltage is applied.

VI. CONCLUSIONS

This study is summarized as follows.

- (1) To avoid interference with other GEO satellites, 35-minute communication interruption (CI) occurs above the equator twice a day in actual QZSS operation.
- (2) Two strategies are prepared for RESSOX during CI: simple averaging and first-order extrapolation. The number of applied voltage data used in averaging or extrapolation is changed from 50 to 100, 200, 300, 500, and 1000 (the rate is every 1.5 s) and evaluated by simulation and experiments.
- (3) In the computer simulation, the best result is given by the case of averaging 100 or 200 applied voltage data, where the standard deviation is 3.29 ns.

- (4) In the basic experiments, the best result is given by the case of averaging 100 applied voltage data, where the standard deviation is 2.80 ns.
- (5) In the actual operation experiment, the maximum synchronization error during CI is 6 ns.

VII. ACKNOWLEDGMENT

This study was carried out as part of the "Basic Technology Development of Next-Generation Satellites" project promoted by the Ministry of Economics, Trade and Industry (METI) through the Institute for Unmanned Space Experiment Free Flyer (USEF).

REFERENCES

- [1] M. Kishimoto, H. Hase, A. Matsumoto, T. Tsuruta, S. Kogure, N. Inaba, M. Sawabe, T. Kawanishi, S. Yoshitomi, and K. Terada, 2007, "*QZSS System Design and its Performance*," in Proceedings of the ION National Technical Meeting, 22-24 January 2007, San Diego, California, USA (Institute of Navigation, Alexandria, Virginia), pp. 405-410.
- [2] J. J. Suter, L. J. Crawford, B. G. Montgomery, and W. E. Swann, 2000, "*Syntonic LLC APL-Developed Technology Makes Its Commercial Debut*," Johns Hopkins APL Technical Digest, Vol. 22, No. 2, pp. 168-175.
- [3] P. A. Koppang, D. Matsakis, and M. Miranian, 2000, "*Alternate Algorithms for Steering to Make GPS Time*," in Proceedings of ION GPS 2000, 19-22 September 2000, Salt Lake City, Utah, USA (Institute of Navigation, Alexandria, Virginia), pp. 933-936.
- [4] D. W. Allan, N. Ashby, and C. C. Hodge, 1997, "*The Science of Timekeeping*" Application Note 1289 (Hewlett-Packard), pp. 60.
- [5] F. Tappero, A. Dempster, T. Iwata, M. Imae, T. Ikegami, Y. Fukuyama, K. Hagimoto, and A. Iwasaki, 2006, "*Proposal for a Novel Remote Synchronization System for the On-Board Crystal Oscillator of the Quasi-Zenith Satellite System*," **Navigation**, **53**, 219-229.
- [6] T. Iwata, M. Imae, T. Suzuyama, H. Murakami, Y. Kawasaki, N. Takasaki, A. Iwasaki, F. Tappero, and A. Dempster, 2006, "*Simulation and Ground Experiments of Remote Synchronization System for Onboard Crystal Oscillator of Quasi-Zenith Satellite*," **Navigation**, **53**, 231-235.
- [7] T. Iwata, Y. Kawasaki, M. Imae, T. Suzuyama, T. Matsuzawa, S. Fukushima, Y. Hashibe, N. Takasaki, K. Kokubu, A. Iwasaki, F. Tappero, A. Dempster and Y. Takahashi, 2007, "*Remote Synchronization System of Quasi-Zenith Satellites Using Multiple Positioning Signals for Feedback Control*," **Navigation**, **54**, 99-108.
- [8] T. Iwata, M. Imae, T. Suzuyama, Y. Hashibe, S. Fukushima, A. Iwasaki, K. Kokubu, F. Tappero, and A. G. Dempster, 2008, "*Remote Synchronization Simulation of Onboard Crystal Oscillator for QZSS Using L1/L2/L5 Signals for Error Adjustment*," **International Journal of Navigation and Observation**, **2008**, Article ID 462062.

- [9] M. Fukui, A. Iwasaki, T. Iwata, and T. Matsuzawa, 2009, “*Hardware Experiments of RESSOX with Ground Station Equipment*,” presented at the 40th Precise Time and Time Interval (PTTI) Systems and Applications Meeting, 1-4 December 2008, Reston, Virginia, USA (not published in Proceedings, but available at <http://www.pttimeeting.org/archivemeetings/2008papers/poster03.pdf>).
- [10] T. Iwata, T. Matsuzawa, K. Machita, and A. Abei, 2010, “*RESSOX Experiments Using Multiple Navigation Signals as Feedback Control*,” in Proceedings of the 2009 International Symposium on GPS/GNSS, 4-6 November 2009, Jeju, South Korea, in press.

