

A Portable Hybrid Ultrasound-Eddy Current NDI System for Metal Matrix Composite Track Shoes

Xiaoliang Zhao, Bao Mi, Tao Qian

Intelligent Automation, Inc., 15400 Calhoun Dr., Suite 400, Rockville, MD 20855

Steven E. Owens, Roger L. Royer Jr.

FBS, Inc., 143 Hawbaker Industrial Drive, Suite 102, PA 16803

Basavaraju B. Raju

U. S. Army RDECOM/TARDEC, 6501 E. 11 Mile Road, MS 255, Warren, MI 48397

Copyright © 2007 SAE International

ABSTRACT

Track shoes made of Metal Matrix Composite (MMC) are light in weight, and can resist high temperature and wear. Defects such as disbond, cracks and porosity can be introduced during the manufacturing process and while in service. Presented in this paper is a portable nondestructive inspection (NDI) system to automatically inspect the tank track shoes for disbond, cracks and porosity defects. The work focuses on the inspection of the track shoe center spline where MMC inserts are attached to the aluminum substrate. A hybrid approach has been developed where an array of broadband high frequency ultrasonic transducers operating in a pulse/echo mode are utilized to detect disbond, and a scanning eddy current probe array is used to detect cracks and porosity. The inspection results agree quite well with immersion ultrasonic C-scan images and destructive tests.

INTRODUCTION

In the past 20 years, metal matrix composites (MMCs) have progressed from primarily a laboratory stage with only narrow commercial significance to a diverse and robust class of material with numerous important applications [1]. MMCs offer a unique balance of physical and mechanical properties. Among them are high thermal and electrical conductivity, good resistance to aggressive environments, good impact and erosion resistance, and good fatigue and fracture properties. In addition, MMCs also add higher strength and stiffness than the matrix alloy, excellent wear resistance and low thermal expansion coefficient. The broad applications of MMCs span from space crafts [2,3] to liquid rocket engines [4] and automobiles [5], etc. This paper presents a nondestructive inspection approach for application to MMCs in Army vehicle track shoe [6].

Cast aluminum track shoes reinforced with MMC inserts at heavy loading areas such as the center spline and sprocket windows are light in weight, and can resist high temperature and wear. A typical track shoe made of aluminum and MMC is shown in Fig. 1.

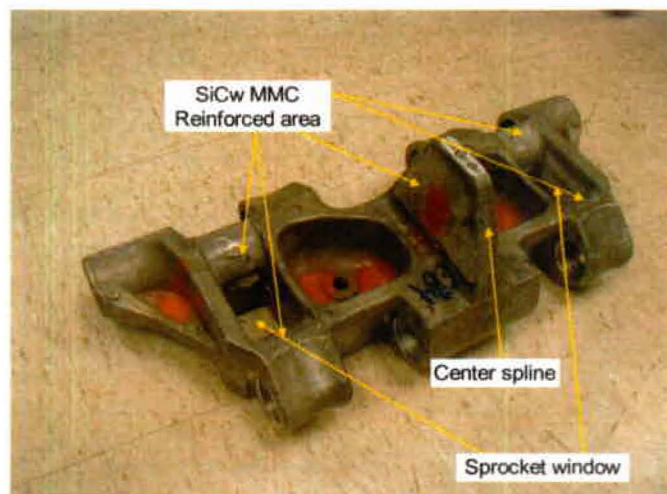

Fig. 1: Tank track shoe to be inspected.

Various defects such as disbonds at the MMC insert-substrate interface, and cracks and porosity within the MMC insert can be introduced during the manufacturing process and/or while in service [7]. Without being detected and fixed, these defects adversely affect vehicle performance, and more importantly, cause catastrophic failures. Presented in this paper is a portable NDI system to automatically inspect the tank track shoes for disbond, cracks and porosity defects. The work focuses on the inspection of the track shoe center spline where MMC inserts are attached to the aluminum substrate. A hybrid approach has been proposed and developed where an array of broadband

Report Documentation Page

Form Approved
OMB No. 0704-0188

Public reporting burden for the collection of information is estimated to average 1 hour per response, including the time for reviewing instructions, searching existing data sources, gathering and maintaining the data needed, and completing and reviewing the collection of information. Send comments regarding this burden estimate or any other aspect of this collection of information, including suggestions for reducing this burden, to Washington Headquarters Services, Directorate for Information Operations and Reports, 1215 Jefferson Davis Highway, Suite 1204, Arlington VA 22202-4302. Respondents should be aware that notwithstanding any other provision of law, no person shall be subject to a penalty for failing to comply with a collection of information if it does not display a currently valid OMB control number.

1. REPORT DATE 10 APR 2007	2. REPORT TYPE N/A	3. DATES COVERED -			
4. TITLE AND SUBTITLE A Portable Hybrid Ultrasound-Eddy Current NDI System for Metal Matrix Composite Track Shoes		5a. CONTRACT NUMBER			
		5b. GRANT NUMBER			
		5c. PROGRAM ELEMENT NUMBER			
6. AUTHOR(S) Xiaoliang Zhao; Bao Mi; Tao Qian; Steven E. Owens; Roger L. Royer Jr.; Basavaraju B. Raju		5d. PROJECT NUMBER			
		5e. TASK NUMBER			
		5f. WORK UNIT NUMBER			
7. PERFORMING ORGANIZATION NAME(S) AND ADDRESS(ES) Intelligent Automation, Inc., 15400 Calhun Dr., Suite 400, Rockville, MD 20855 FBS, Inc., 143 Hawbaker Industrial Drive, Suite 102, PA 16803 US Army RDECOM-TARDEC 6501 E 11 Mile Rd Warren, MI 48397-5000		8. PERFORMING ORGANIZATION REPORT NUMBER 16768			
		9. SPONSORING/MONITORING AGENCY NAME(S) AND ADDRESS(ES)			
10. SPONSOR/MONITOR'S ACRONYM(S) TACOM/TARDEC		11. SPONSOR/MONITOR'S REPORT NUMBER(S) 16768			
		12. DISTRIBUTION/AVAILABILITY STATEMENT Approved for public release, distribution unlimited			
13. SUPPLEMENTARY NOTES Presented at 2007 SAE World Congress, Detroit, MI, USA, The original document contains color images.					
14. ABSTRACT					
15. SUBJECT TERMS					
16. SECURITY CLASSIFICATION OF:			17. LIMITATION OF ABSTRACT SAR	18. NUMBER OF PAGES 9	19a. NAME OF RESPONSIBLE PERSON
a. REPORT unclassified	b. ABSTRACT unclassified	c. THIS PAGE unclassified			

high frequency ultrasonic transducers operating in a pulse/echo mode is utilized to detect disbond, and a scanning eddy current probe array is used to detect crack and porosity. The portable NDI system contains a two-side fixture with one side holding a two-dimensional array of ultrasonic transducers and the other side holding a scanning one-dimensional eddy current probe array. By flipping the fixture at the center spline to inspect both sides for all defect types, the complete health conditions are derived for both sides of the shoe.

The prototype fixture for the ultrasonic side has been designed and fabricated. It was tested on both used and brand new shoes and the results are confirmed with immersion ultrasonic C-scan images and destructive tests. The coupling of mechanical energy into the MMC insert is through a special dry couplant pad, so that no messy liquid couplant is required, and a uniform and consistent coupling condition is achieved for highly repeatable inspection. The fixture uses 0.5" diameter ultrasonic transducers with a center frequency of 10 MHz for disbond detection. This resulted in a high spatial resolution in the thickness direction for the MMC inserts while keeping reasonable area coverage [6]. For the eddy current inspection side, the inspection methodology has been proved with the MMC specimens and a four-probe scanning array is to be designed.

The entire inspection process is automated with the control of a rugged lunch box computer. A graphical user interface (GUI) is developed in LabVIEW to execute the inspection, extract the defect information, and report the results. Note that besides the track shoe that was used to demonstrate the NDE technique, this NDE device will also have a very wide application for many MMC structures in the ground (land) vehicles (including the passenger cars), aircrafts, aerospace and Navy vessels.

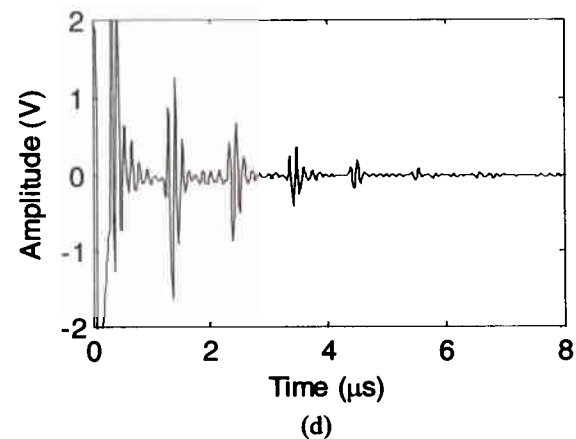
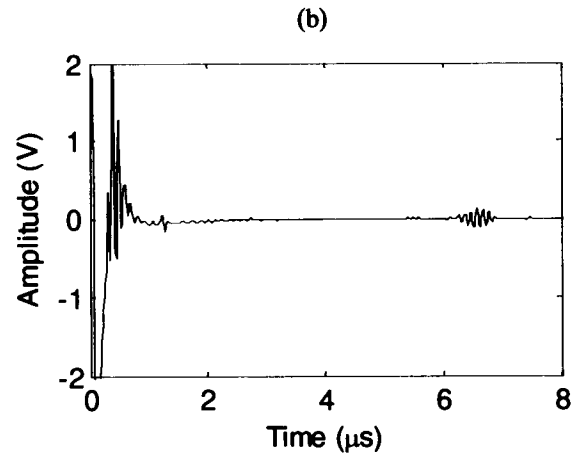
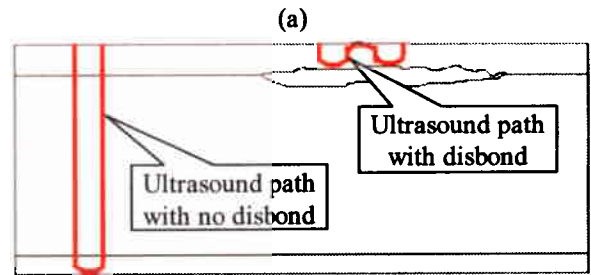
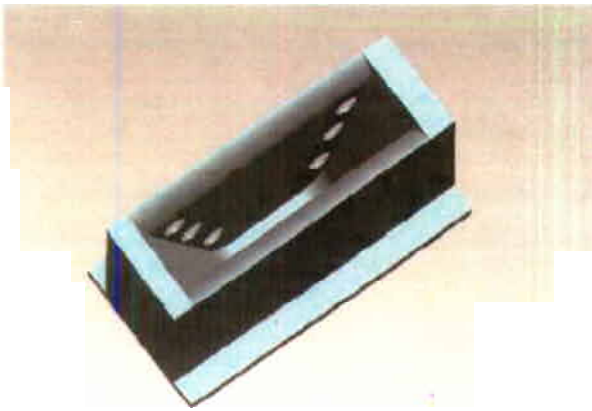

Fig. 2: Illustration of pulse-echo method for disbond detection. (a) Conventional contact transducer on the tank shoe; (b) Illustration of the ultrasound paths; (c) Signal at location with no disbond; (d) Signal at location with disbond.

ULTRASONIC INSPECTION FOR DISBOND

GENERAL APPROACH

Fig. 2 illustrates how a disbond at the boundary between the MMC insert and the aluminum substrate is detected by the pulse-echo method with a contact ultrasonic transducer. Fig. 2a shows the center spline section with a contact transducer placed on its surface. The possible ultrasonic propagation paths are illustrated in Fig. 2b. When no disbond is present, ultrasonic energy propagates through the MMC-substrate boundary and is reflected from the back wall, with the corresponding signals as shown in Fig. 2c. At the area of the disbonded region, the ultrasonic energy is bounced back and forth between the surface and the MMC-substrate interface, with the corresponding signals as shown in Fig. 2d. Multiple reflections are present since the thin layer of MMC is less attenuative than the entire thickness of the center spline.



(a)

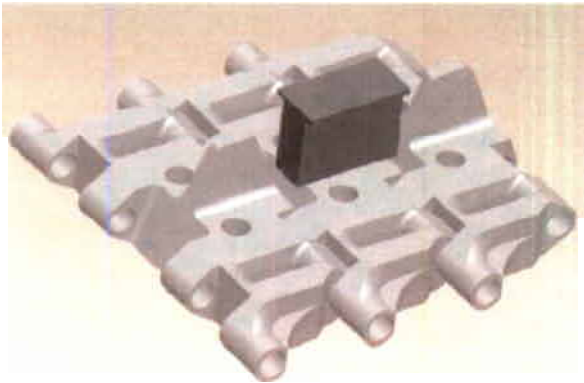

(b)

Fig. 3: Concept design of the sensor fixtures. (a) Fixture for the center spline; (b) fixture clamped on the shoe.

The general concept design of a portable device is shown in Fig. 3: a clamped-on fixture that contains a 2-D array of ultrasonic sensors on one side and a 1-D scanning array of eddy current probes on the other side.

PROTOTYPE FIXTURE DESIGN

To prove the concept of a clamped-on fixture, a prototype that hosts four ultrasonic transducers has been designed and fabricated to detect disbond in the center spline. Fig. 4 shows the fixture assembly and how pressure can be applied on each individual transducer by springs in detail. The designed fixture has the following features:

Fixed-angle separation: Transducer housing plate and the backing plate for clamping on to a spline are designed at 12 degree angle to parallel, which matches the angle between left and right faces of spline. Angled counter bores are designed to provide increased surface area for clamping pressure between housing and clamping plate.

Spring-loaded transducer assemblies (Fig. 4c): Individually loaded transducers allows for compliance

with surface irregularities (depressions, angular deviations). The design makes it possible to adjust contact pressure by installing spacers (washers). While the spring-loaded transducer introduces a contact pressure variance range when the surface is not level, this range can be reduced by using a stiffer spring (higher K).

Precision PTFE-coated stainless steel transducer sleeve: The low-friction PTFE surface reduces binding between the transducer subassembly and the housing so that the pressure applied on the transducer is not affected by the friction force. Another advantage is that it is corrosion resistant.

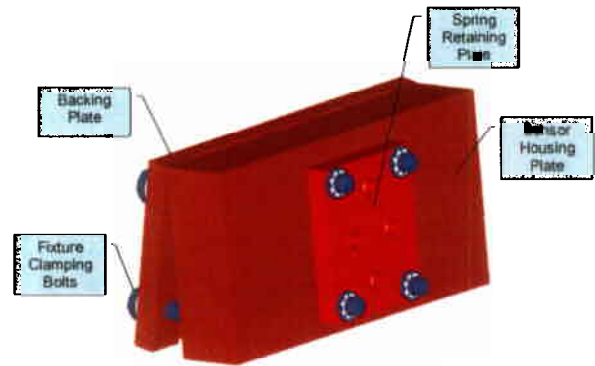

(a)

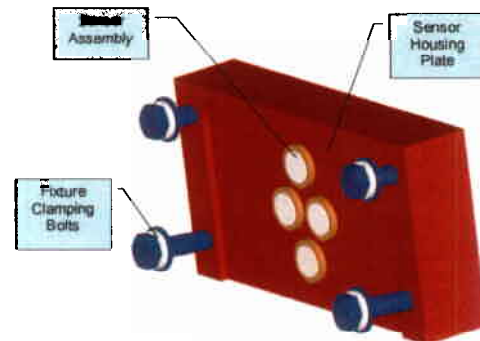

(b)



(c)

Fig. 4: Prototype fixture design. (a) Fixture assembly; (b) sensor housing plate assembly; view of sensor contact surface with backing plate removed; (c) ultrasonic transducer assembly.

TESTING OF THE PROTOTYPE FIXTURE

The prototype fixture has been attached to various shoes with four 10-MHz transducers for disbond detection test, as shown in Fig. 5. Note that a special dry

couplant of 2.3 mm thick is placed between the transducers and the spline surface. All the shoes have been C-scanned and the images are available on the spline section for ground truth confirmation. To help understand the ultrasonic signals obtained by the contact transducers, a typical signal is shown in Fig. 6 with the echoes marked. The 2.3 mm thick Elastomer dry couplant produces a large reflection first and the reflections from the disbonded area (if present) follow.



Fig. 5: Tank shoes with prototype fixture attached.

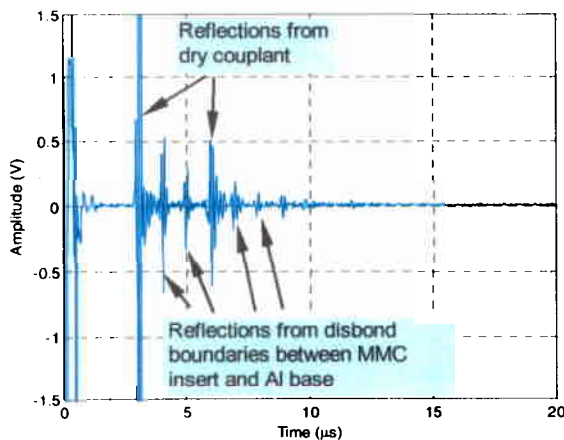

Fig. 6: Typical ultrasonic signal received by contact transducer with echoes marked.

The testing results for two typical shoes are shown in figures Fig. 7 and Fig. 8. The first shoe #4 is a new shoe that has never been used. The second shoe #6 is a used shoe and has quite a bit of surface wear at the spline section. This is also confirmed by the time-of-flight of the disbond boundary reflection signal that reveals the Shoe #4 (new shoe) has a thicker MMC insert than Shoe #6 (used shoe).

As can be observed from Fig. 7 and Fig. 8, the fixture with contact transducers works well for detecting the disbond defects. For used shoes, the results are very reliable when comparing to the C-scan images due to

the flat surface caused by the surface wear. For brand-new shoes, the surface is uneven around the edge of the MMC insert. The uneven surface may cause coupling problem and produce unreliable results. This problem can be solved by the surface preparation before inspection.



(a) Real picture of shoe #4

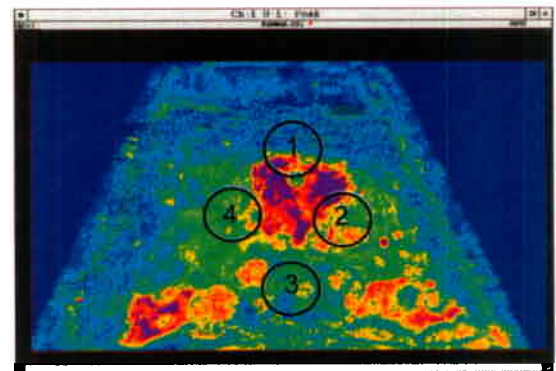

(b) C-scan image

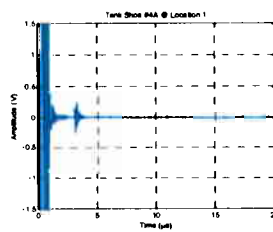

(c) Signal @ 1

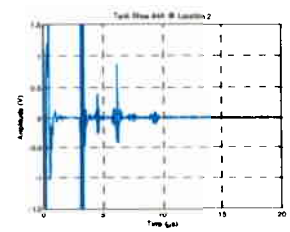

(d) Signal @ 2

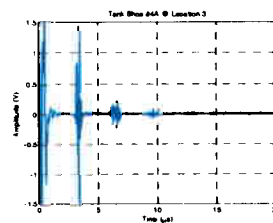

(e) Signal @ 3

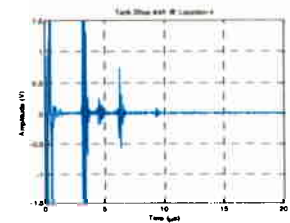

(f) Signal @ 4

Fig. 7: Test results compared to the ultrasonic C-scan image for shoe #4. Signals at Locations 2 and 4 show low level of disbond. The signal

received at Location 1 shows no echoes from dry couplant. The uneven surface at that area may have caused the weak coupling.



(a) Real picture of shoe #6

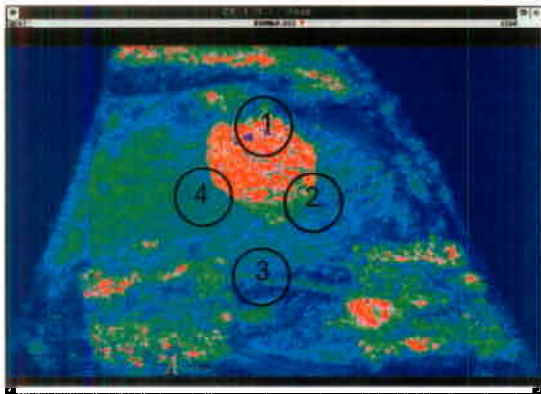

(b) C-scan image

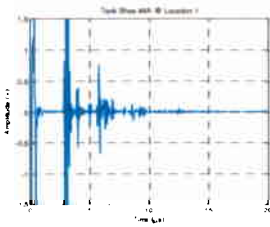

(c) Signal @ 1

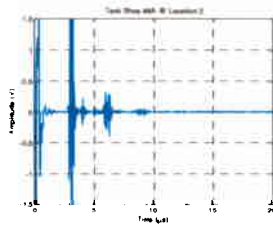

(d) Signal @ 2

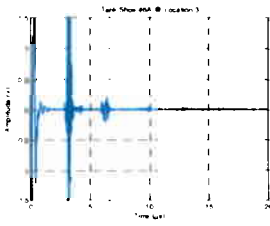

(e) Signal @ 3

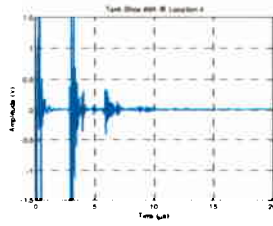

(f) Signal @ 4

Fig. 8: Testing results compared to C-scan image for shoe #6. All four signals agree with the C-scan images well.

FULL VERSION FIXTURE DESIGN

The prototype fixture described in the previous section was used for proof-of-concept. The full version of the fixture needs a large number of the transducers in order to cover the entire surface of the center spline. Spacing between sensors in the proof-of-concept design needs to be reduced to meet the requirement of locating disbonded regions with a minimum size of 0.5" diameter.

A cam-lock system (or similar clamping method) for applying contact pressure would be desirable over the currently-implemented bolt system. This will be necessary for any future iteration with increased number of sensors, as the total preload spring force will increase with each transducer added. Currently, the design allows for 0.1" surface deviation. The amount of preload force produced by the springs (the force required to displace the transducer from its initial position) is calculated to be 8.7 lbs. At maximum transducer displacement (the point at which the surface of the transducer is flush with the housing plate), the force is calculated to be 10.2 lbs. Because the surface of the spline is neither flat nor smooth, the design required a degree of flexibility. By taking the above thoughts into account, a full version ultrasonic fixture has been designed as shown in Fig. 9.

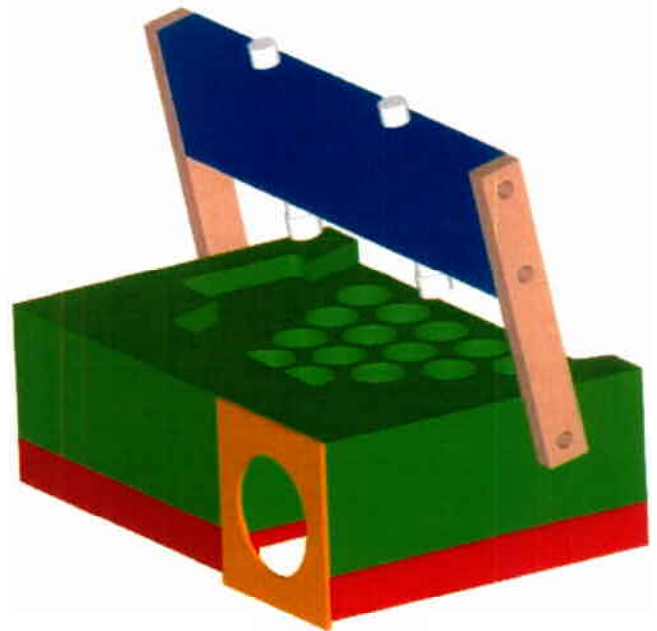

Fig. 9: 3D model of the full version fixture design.

EDDY CURRENT INSPECTION OF CRACK AND POROSITY

TESTING ON MMC SPECIMENS

An eddy current inspection system manufactured by a German company IZFP is used for detecting the porosity and surface cracks. The eddy current system is mainly composed of an instrumentation board, which is designed for PC-aided eddy current testing. The connection between the eddy current board and the PC

is realized by network cable. This board is preferred by IAI because once the raw eddy current data is transferred to the PC computer, powerful signal processing algorithms can be developed to enhance the capability of defect detection and quantification. The system is shown in Fig. 10. The eddy current board is packaged in the box shown on the right in the picture.



Fig. 10: Eddy current system

The basic output of an eddy current system is the complex impedance measured by the probe. The impedance is affected by a lot of things, such as the lift-off distance, frequency, conductivity, and of course the defect on or near the inspected object surface.

The impedance can be displayed in an impedance plane to show its trace when certain parameter is varied, such as lift off, location of the probe, etc. It can also be displayed as two time based curves which show how the real part and the imaginary part of the impedance vary along time. The time based plots are used to show the results. The eddy current system can run four frequencies simultaneously and the results from four frequencies are represented with four different colors. Two MMC specimens were prepared. The #1 is defect free and the #2 is with a porous section at the center, as shown in Fig. 11. For both specimens, the impedance is measured while the eddy current probe was scanned across the specimen. The results are shown in Fig. 12 and Fig. 13. The eddy current probe is balanced on the porosity free surfaces. Fig. 12 shows that the impedance stays constantly in the origin for Specimen #1. For Specimen #2, the impedance appreciably changes while the probe goes into the porous region specified by the shaded area in Fig. 11(b). Among the four frequencies (50 KHz, 100 KHz, 250 KHz, and 1 MHz), the frequencies 100 KHz and 250 KHz respond more appreciably than the other two frequencies.

Compared to the ultrasonic approach, the eddy current technique does not require coupling media and it produces relatively reliable results for porosities and surface cracks.

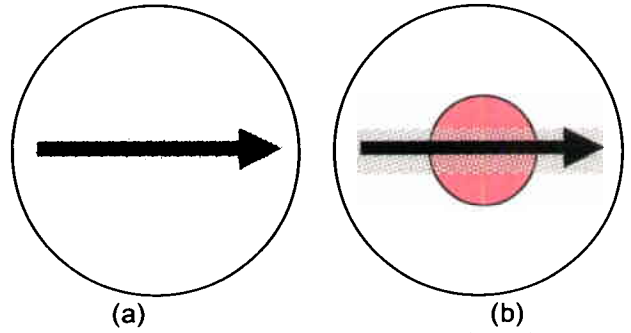

Fig. 11: Eddy current probe scanning across the MMC specimen. (a) Specimen #1: porosity free; (b) Specimen #2: porosity at the center (shaded by pink color).

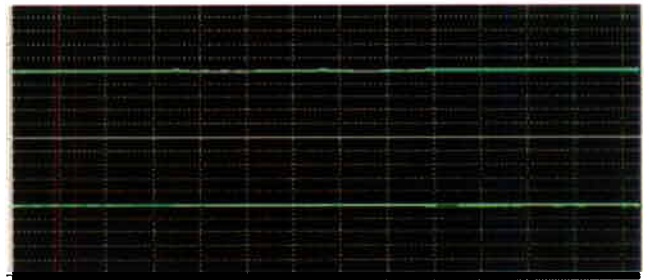

Fig. 12: Eddy current results from the porosity free specimen #1.

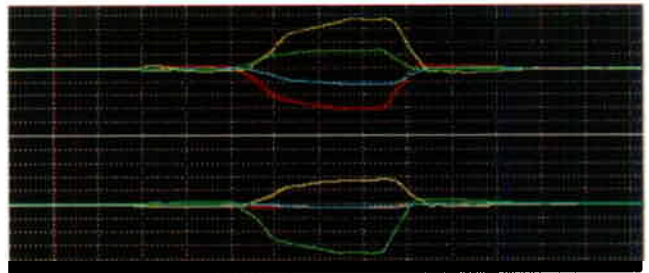

Fig. 13: Eddy current results from the porosity free specimen #2.

TESTING ON SHOE FOR SURFACE CRACK DETECTION

The same eddy current system was used to detect the surface crack (or material loss at surface) on the tank shoe center spline.

Before an automatic scanning component associated with the eddy current system is developed, a manual scan was performed to collect the eddy current signals to prove the concept. For each tank shoe spine surface, the probe was scanned three times to cover the entire shoe, as shown in Fig. 14. While the probe was being scanned across the surface, the eddy current signals were acquired at a constant rate and displayed in time basis. The manual scanning was kept at an approximately constant speed and there was a pause at

the beginning and the end. So the time based display can not be linearly mapped to the locations and the results are only for a qualitative study of how the eddy current results will responds to the surface anomalies.

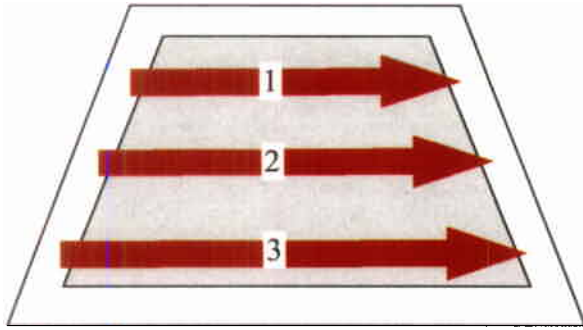

Fig. 14: Schematic of eddy current probe scanning over the shoe spline surface.

Fig. 15 shows the actual picture of a used tank shoe spline. Note that the surface contains two surface cracks marked with 2 and 3. The marked area with number 1 is a discontinuity at the boundary between the edge of MMC insert and the surrounding Al base material. This kind of discontinuity is very common in both used and new shoes.

The corresponding eddy current time based signals are shown in Fig. 16. Each of the three pictures represents one of the three scans illustrated in Fig. 14. The four colors in the eddy current results represent four different eddy current frequencies. The corresponding eddy current signals to marked areas with numbers in Fig. 15 are marked with same numbers in Fig. 16. It can be concluded that the eddy current signals respond well to the surface conditions. Some of the deviations in the eddy current signals at the start and the end of the time based displays are caused by resting the probe on the edge of the inspected shoe spline.

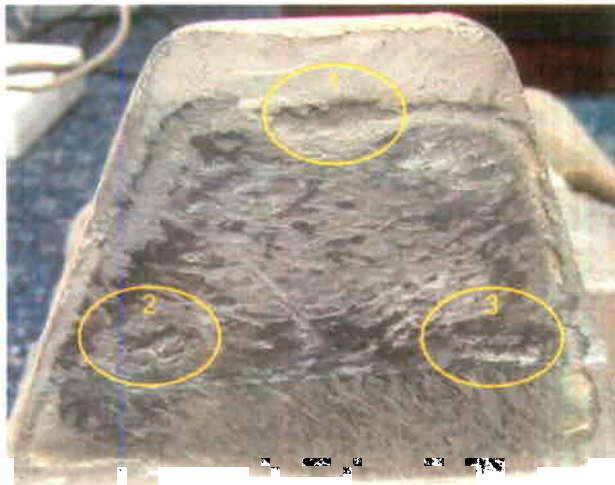

Fig. 15: Used tank shoe with surface cracks

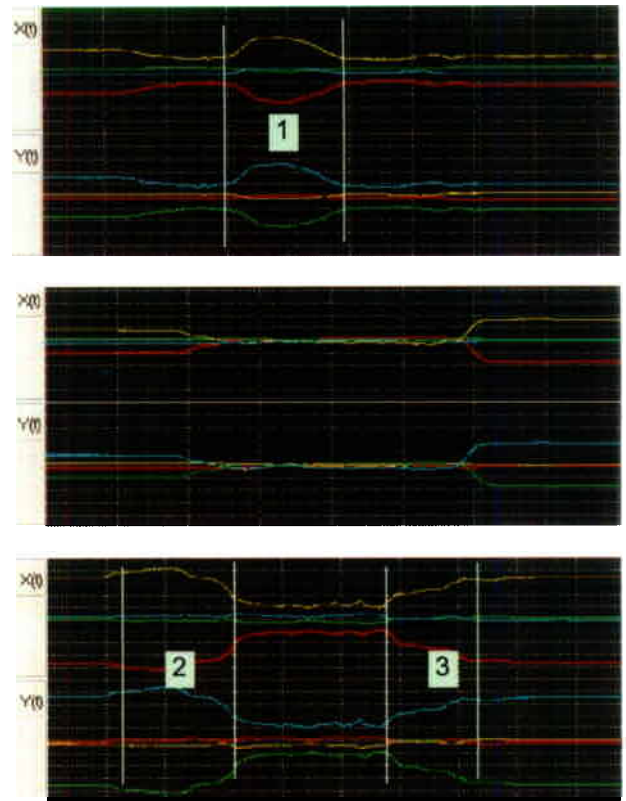

Fig. 16: Eddy current scanning results for the used tank shoe spline with surface defects as shown in Fig. 15.

HARDWARE – MULTIPLEXED ACQUISITION SYSTEM

Fig. 17 illustrates the hardware configuration for the ultrasonic signal acquisition system. While this configuration is designed directly for the transducer array used for disbond detection, it is extendable/scalable to the crack and porosity detection. Currently the lunch box computer is equipped with an ADLink high speed A/D card and Matec TB1000 tone burst card. It is ready for collecting ultrasonic signals from a single transducer in pulse-echo mode or signals from a pair of transducers in through-transmission mode. To automate the signal acquisition from an array of transducers in a pulse-echo mode, a multiplexer is required.

A 16-channel multiplexing board has been designed and fabricated. Up to 16 transducers can be connected to the pulser/receiver through this multiplexer card. Each of the 16 transducers can be selected to be either the transmitter or the receiver. The computer selects channels through a USB based I/O board. Four I/O pins are used to select one of the 16 input channels as transmitter and another 4 I/O pins are used to select one of the 16 output channels as receiver. Reed mechanical relay was used to open or shut the channels. Compared to solid-state relays, the mechanical relays have lower contact resistance, higher switching voltage, lower across open contact capacity. The drawback of the

mechanical relay is that it has longer operation time, which is not critical in our application because switching frequency is not high. The mechanical relay also dramatically reduces the cross talk between channels. To prevent the input signal from shorting to output, a hardware logic system was added to the design, which automatically shut down all output channels when the same channel is selected for both input and output.

(size and location). This function is desired to be implemented in Matlab. Data exchange is realized by saving the data in text files and reading the data from text files.

- **Graphical and numerical results presentation.** It is desired to display the defect information on the GUI graphically and numerically.

After the above modules have been designed and realized, an overall graphical user interface (GUI) is preferable to coordinate all above functions to perform a specified job. The GUI reads the data acquisition scheme from an external text file. This data acquisition scheme text file will include multiple rows. Each row represents one data acquisition iteration. The values in each row will specify the parameters of the hardware, as follows:

1. **For multiplexer:** transducer number(s)
2. **For acquisition card:** sampling rate, averaging number, record length
3. **For tone burst pulser/receiver card:** gain, frequency, pulse width, LPF, HPF

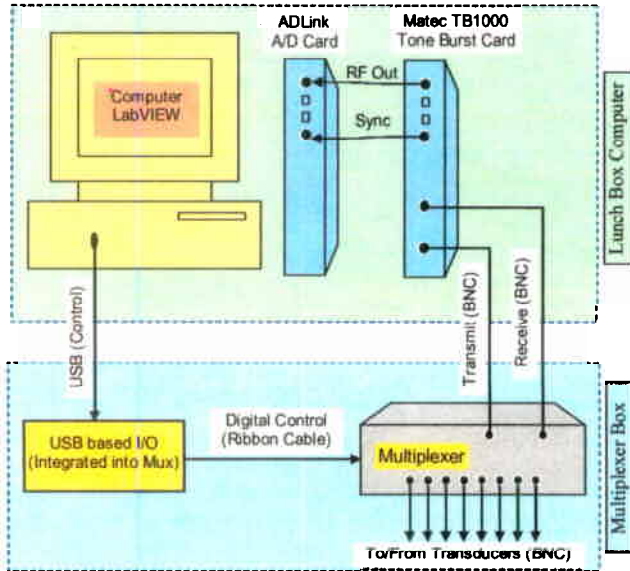

Fig. 17: Hardware schematic.

SOFTWARE DEVELOPMENT

The software has been developed in LabVIEW. The primary objective of the LabVIEW program is to automate the acquisition process of the multiple-channel ultrasonic data and the eddy current data with a high speed ADLink A/D card, a Matec TB1000 Tone Burst Pulser Receiver Card, and the USB-controlled multiplexer. The design of the software is modular, as shown by the block diagram in Fig. 18. The basic modules of the software include the following:

Control of multiplexer card through a USB port. Sending control signals to multiplexer card to select the specified transducer(s) through USB based I/O port.

Configuration of Matec TB-1000 tone burst pulser/receiver card. This includes the setting of the parameters, such as gain, mode (pulse-echo or through-transmission), pulse width, repetition rate, filter setting, etc.

Data acquisition via ADLink high speed A/D card. This includes the setting of the acquisition parameters, such as sampling rate, averaging number, record length, etc. The acquired data will be saved into a text file with specified file name and appropriate index number.

Data processing. This includes processing the raw ultrasonic data to extract the defect information

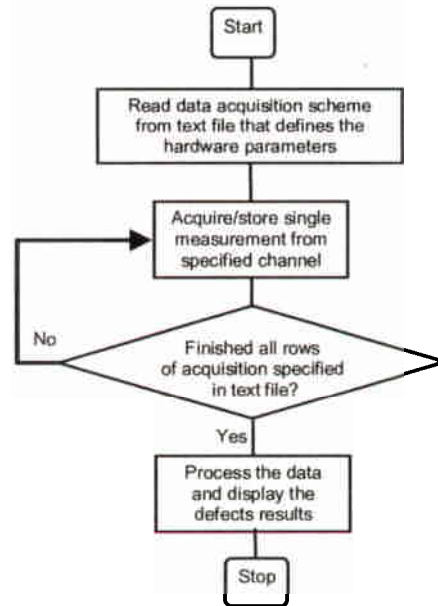

Fig. 18: Operational flow chart.

CONCLUSION

A portable hybrid ultrasonic/eddy current system is being developed for inspecting aluminum tank shoe center spines reinforced with MMC inserts. It is concluded that a two-sided fixture is a reasonable solution with one side holding a 2D array of ultrasonic transducers for disbond inspection, and the other side holding a scanning 1D eddy current probe array for surface crack and porosity inspection. For the ultrasonic side, a prototype fixture has been designed and fabricated to hold four ultrasonic transducers for disbond detection. The fixture has been tested on both used and

new tank shoes. The results show that clean signals can be obtained with the fixture and the disbond can be detected by checking the reflected signals. A full version ultrasonic fixture is being designed that will cover the entire surface of the center spline. For the eddy current side, a scanning 1D eddy current probe array is the best solution, which has been concept proved by manual testing for both porosity and surface crack. The integration of the compact hardware and modular software design makes possible an automated inspection system that can be deployed both in a manufacturing line and in field.

ACKNOWLEDGMENTS

This work is financially supported by Army TARDEC through an SBIR II contract number W56HZV-04-C-0692.

REFERENCES

1. D.B. Miracle, "Metal matrix composites – from science to technological significance", *Composites Science and Technology*, v65, n15-16, pp 2526-40, 2005

2. S. Rawal, "Metal-matrix composites for space applications", *JOM*, v53, n4, pp.14-17, 2001
3. G.Y. Baaklini, D.J. Roth, H.E. Kautz, R.N. Yancey, R. Gibson, "Nondestructive evaluation of metal matrix composites for aerospace applications", 1997 International Conference on Quality Control by Artificial Vision, pp. 55-9, 1997
4. J.S. Shelley, R. LeClaire, J. Nichols, "Metal-matrix composites for liquid rocket engines", *JOM*, v53, n4, pp.18-21, 2001
5. S.V. Prasad, R. Asthana, "Aluminum metal-matrix composites for automotive applications: tribological considerations", *Tribology Letters*, v17, n3, pp.445-53, 2004
6. X. Zhao, C. Kwan, R. Xu, T. Qin, etc, "Non-destructive inspection of metal matrix composites using guided waves", *Review of Quantitative Nondestructive Evaluation*, V. 23, pp. 914-921, 2004
7. Y.D. Huang, L. Froyen, M. Wevers, "Quality control and nondestructive tests in metal matrix composites", *Journal of Nondestructive Evaluation*, v20, n3, pp.113-32, 2001