



**NAVAL
POSTGRADUATE
SCHOOL**

MONTEREY, CALIFORNIA

THESIS

**A SPACE-TIME FLOW OPTIMIZATION MODEL
FOR NEIGHBORHOOD EVACUATION**

by

William P. Langford

March 2010

Thesis Advisor:
Second Reader:

David L. Alderson
Richard L. Church

Approved for public release; distribution is unlimited

REPORT DOCUMENTATION PAGE			<i>Form Approved OMB No. 0704-0188</i>	
Public reporting burden for this collection of information is estimated to average 1 hour per response, including the time for reviewing instruction, searching existing data sources, gathering and maintaining the data needed, and completing and reviewing the collection of information. Send comments regarding this burden estimate or any other aspect of this collection of information, including suggestions for reducing this burden, to Washington headquarters Services, Directorate for Information Operations and Reports, 1215 Jefferson Davis Highway, Suite 1204, Arlington, VA 22202-4302, and to the Office of Management and Budget, Paperwork Reduction Project (0704-0188) Washington DC 20503.				
1. AGENCY USE ONLY (Leave blank)		2. REPORT DATE March 2010	3. REPORT TYPE AND DATES COVERED Master's Thesis	
4. TITLE AND SUBTITLE A Space-Time Flow Optimization Model for Neighborhood Evacuation			5. FUNDING NUMBERS	
6. AUTHOR(S) William P. Langford				
7. PERFORMING ORGANIZATION NAME(S) AND ADDRESS(ES) Naval Postgraduate School Monterey, CA 93943-5000			8. PERFORMING ORGANIZATION REPORT NUMBER	
9. SPONSORING /MONITORING AGENCY NAME(S) AND ADDRESS(ES) N/A			10. SPONSORING/MONITORING AGENCY REPORT NUMBER	
11. SUPPLEMENTARY NOTES The views expressed in this thesis are those of the author and do not reflect the official policy or position of the Department of Defense or the U.S. Government. IRB Protocol number _____.				
12a. DISTRIBUTION / AVAILABILITY STATEMENT Approved for public release; distribution is unlimited			12b. DISTRIBUTION CODE	
13. ABSTRACT (maximum 200 words) We model the evacuation of vehicles in a residential neighborhood using a space-time network flow representation. Our model solves for "best case" evacuation routes and clearing times, as could be identified and implemented by a central authority. Our models are large but can be solved efficiently and quickly. By solving many model excursions for different input parameters, we can assess the importance of different model features, as well as evaluate evacuation behavior for a variety of what-if scenarios. We apply this model to the Mission Canyon neighborhood near Santa Barbara, California, and contrast our results to a previous simulation-based study.				
14. SUBJECT TERMS Evacuation Network Flow Optimization Space-Time network			15. NUMBER OF PAGES 61	
			16. PRICE CODE	
17. SECURITY CLASSIFICATION OF REPORT Unclassified	18. SECURITY CLASSIFICATION OF THIS PAGE Unclassified	19. SECURITY CLASSIFICATION OF ABSTRACT Unclassified	20. LIMITATION OF ABSTRACT UU	

NSN 7540-01-280-5500

Standard Form 298 (Rev. 2-89)
Prescribed by ANSI Std. Z39-18

THIS PAGE INTENTIONALLY LEFT BLANK

Approved for public release; distribution is unlimited

**A SPACE-TIME FLOW OPTIMIZATION MODEL
FOR NEIGHBORHOOD EVACUATION**

William P. Langford
Lieutenant Junior Grade, United States Navy
B.A., University of Colorado Boulder, 2007

Submitted in partial fulfillment of the
requirements for the degree of

MASTER OF SCIENCE IN OPERATIONS RESEARCH

from the

**NAVAL POSTGRADUATE SCHOOL
March 2010**

Author: William P. Langford

Approved by: David L. Alderson
Thesis Advisor

Richard L. Church
Second Reader

Robert F. Dell
Chairman, Department of Operations Research

THIS PAGE INTENTIONALLY LEFT BLANK

ABSTRACT

We model the evacuation of vehicles in a residential neighborhood using a space-time network flow representation. Our model solves for “best case” evacuation routes and clearing times, as could be identified and implemented by a central authority. Our models are large but can be solved efficiently and quickly. By solving many model excursions for different input parameters, we can assess the importance of different model features, as well as evaluate evacuation behavior for a variety of what-if scenarios. We apply this model to the Mission Canyon neighborhood near Santa Barbara, California, and contrast our results to a previous simulation-based study.

THIS PAGE INTENTIONALLY LEFT BLANK

TABLE OF CONTENTS

I.	INTRODUCTION.....	1
II.	LITERATURE REVIEW	3
	A. LARGE-SCALE EVACUATIONS.....	3
	B. SMALL SCALE EVACUATIONS	4
	C. OUR CONTRIBUTION IN CONTEXT.....	6
III.	MODEL FORMULATION.....	7
	A. THE SPATIAL MODEL.....	7
	B. THE SPACE-TIME MODEL.....	10
	C. THE MISSION CANYON EXAMPLE	13
IV.	RESULTS	17
	A. DETERMINING A BASELINE.....	17
	B. DOES STAGGERING MATTER?	21
	C. THE IMPORTANCE OF FOOTHILL ROAD.....	24
	1. Reduction in Throughput Capacity	24
	2. Loss of an Egress Point.....	25
	D. IMPACT OF ROAD OR INTERSECTION CLOSURES.....	25
	1. Varying the Flow Along Tunnel Road	26
	2. Impact of Road Closures.....	29
	3. Impact of Severely Limiting Intersection Flow.....	31
V.	CONCLUSION	35
	A. SUMMARY	35
	B. FUTURE WORK.....	36
	1. Adding Additional Egress Points (Arcs or Sinks).....	36
	2. Input of Data	36
	3. Attacking the Network	37
	4. Visualization of Results	38
	5. Vehicle Tracking	38
	C. FINAL THOUGHTS	39
	LIST OF REFERENCES.....	41
	INITIAL DISTRIBUTION LIST	43

THIS PAGE INTENTIONALLY LEFT BLANK

LIST OF FIGURES

Figure 1.	Mission Canyon neighborhood (From Church & Sexton, 2002).....	7
Figure 2.	A simple neighborhood and its spatial network representation.	8
Figure 3.	A simple spatial network and its representation in the space-time network....	11
Figure 4.	The Mission Canyon neighborhood with intersections and sink nodes identified. (After Church & Sexton, 2002).	14
Figure 5.	Network Representation of the Mission Canyon neighborhood with each of the 21 critical intersections labeled.	16
Figure 6.	Cumulative vehicle evacuation by exit location.	17
Figure 7.	Vehicle clearing times and distribution by region	18
Figure 8.	Cumulative vehicle evacuation by exit location (two vehicles per driveway).	19
Figure 9.	Vehicle clearing times and distribution by region (two vehicle per driveway).	19
Figure 10.	Clearing times by region, staggered departures (top), simultaneous departures (bottom). Note the staggered departure case repeats Figure 7.	22
Figure 11.	Clearing times by region, staggered departure (top), simultaneous departure (bottom). Note that the staggered departure case repeats Figure 9.....	23
Figure 12.	The Mission Canyon Neighborhood with lower Tunnel Road highlighted (After Church & Sexton, 2002).	27
Figure 13.	A network representation of Mission Canyon with critical intersections shaded in light grey.....	32

THIS PAGE INTENTIONALLY LEFT BLANK

LIST OF TABLES

Table 1.	Critical intersections of the Mission Canyon neighborhood.....	15
Table 2.	Comparison of clearance times for the Vital Report and for the staggered and simultaneous departure scenarios of our model.	20
Table 3.	Results of varying vehicle capacity and egress routes along Foothill Road.	24
Table 4.	Impact of Tunnel Road capacities on clearance times. One car per driveway.....	28
Table 5.	Impact of Tunnel Road capacities on clearance times. Two cars per driveway.....	29
Table 6.	Effects of intersection closures or restrictions on the evacuation of Mission Canyon.	31

THIS PAGE INTENTIONALLY LEFT BLANK

EXECUTIVE SUMMARY

We model the evacuation of vehicles in a residential neighborhood using a space-time network flow representation. Our model solves for “best case” evacuation routes and clearing times, as could be identified and implemented by a central authority. Our models are large but can be solved efficiently and quickly. By solving many model excursions for different input parameters, we can assess the importance of different model features as well as evaluate evacuation behavior for a variety of what-if scenarios. We apply this model to the Mission Canyon neighborhood near Santa Barbara, California, and contrast our results to a previous simulation-based study.

We develop two network flow models to quantify the clearing times of neighborhood evacuations. Our first model is a spatial model that finds minimum cost evacuation routes. We represent the Mission Canyon neighborhood as a network consisting of supply (e.g., homes), transshipment nodes (e.g., intersections), and connecting arcs (e.g., road segments), all of which are connected to a “super-sink” egress point. From this spatial model, we create a space-time model by replicating the spatial network for each of T time periods, and we solve for best case evacuation flows in space and time.

We first develop a baseline evacuation scenario of Mission Canyon and compare it to the previous analysis of Church and Sexton (2002). We find that our model produces similar evacuation clearance time estimates as those obtained by the more time intensive micro-simulations. With this baseline established, we exercise the model to assess the effects that various changes to our model inputs or network design have on neighborhood evacuation time. Because our model is simple and solves quickly, we are able to consider several scenarios.

We find that staggering the departure times of evacuees does not result in an appreciably longer clearing time than an evacuation with simultaneous departures. We conclude that the presence of background traffic flow on a major evacuation road with non-evacuation traffic does not greatly impact the neighborhood evacuation, but rather

that the overall evacuation time is more largely impacted by the interior roads of the neighborhood. We estimate that losing access to one particular evacuation road would more than double the time to evacuate the neighborhood for both a one- and two-car-per-household scenario. This crippling effect results when an intersection node at either end of this road segment is blocked, and we argue that efforts should be taken to ensure this road is fortified against possible closure due to natural or deliberate attacks.

We ran analyses on our network to determine the effects on evacuation time if any of 21 “critical intersections” are either isolated from the network or have their throughput capacity severely limited. Of the 21 intersections, we find that eight of them would isolate some number of houses from the network if we completely disconnect them. Similarly, we find that complete isolation of 13 of the 21 intersections results in longer evacuations. The least severe of these increases evacuation time by 50 seconds (0:50), while the most severe closure increases clearing time by 45:00.

We examine the results on neighborhood clearing time if each of these same 21 intersections has their throughput capacity limited to one vehicle per time period (360 per hour). These analyses show that 14 of the 21 intersections would have no impact on overall clearance times if restricted. For the other seven, the least severe delay was 0:10, while the most severe increased evacuation times by 22:10.

There are many natural extensions to this work, including modifying the network to allow for additional routes and estimating evacuation times under these conditions. Similarly, we can add an additional exit point to the network to estimate how evacuation times are affected.

ACKNOWLEDGMENTS

Where to begin...

To my parents, **Joseph** and **Patricia Gonzales**, I am who I am today because of you. For that I am eternally grateful. I'm sure you know I love you, but might as well put it in writing.

To my brother, **Remy**, thanks for being you. If there is one thing in this world that drives me to succeed, it is you.

To **Professor David L. Alderson**, I'm sure I don't need to say that I wouldn't be here were it not for your guidance and knowledge. I will likely have a permanent aversion to red ink because of you, but I am also an immensely smarter person because of your tutelage. Time to steam.

To **Professor Richard L. Church**, thank you for suggesting the Mission Canyon as a thesis topic, and providing invaluable support throughout. I owe you an enormous debt of gratitude.

To the VTC group (**Emily, Jean, Nada, Dani, Rob, Micah, Matt**), thank you for the weekly commitment to sit and collaborate, the insight I gained during our jaunts was crucial to completing this work.

To all those friends and family who were there for me (and there are too many to list here), thank you.

THIS PAGE INTENTIONALLY LEFT BLANK

I. INTRODUCTION

During a disaster, either natural (e.g., wildfires, hurricanes) or man-made (e.g., terrorist attacks), the ability to evacuate an at-risk population can literally be the difference between life and death. In 1991, 25 people died when the Oakland Hills neighborhood of California caught fire, spreading rapidly through the neighborhood with the assistance of strong winds (Church & Sexton, 2002). The loss of life during this fire led to an increased interest in neighborhood evacuation modeling, as concerned communities sought to improve their evacuation plans.

The goal of evacuation modeling is to determine whether a given area can be evacuated in the event of a disaster, and how long it would take. Determining evacuation times is not an easy task to achieve, as the conditions present during an evacuation do not exist under normal circumstances. Unusually large volumes of evacuees on a given route, as well as a heightened emotional state caused by the emergency, are some examples of conditions that are unique to an evacuation scenario. While some of these conditions may be difficult to predict accurately beforehand, we understand that the traffic demand on neighborhood evacuation routes depends on the number of vehicles in a given area in the time preceding an evacuation. We use this notion of “supply” and “demand” to develop an understanding of evacuation dynamics.

There is no shortage of methods relied upon to inform decision makers about the dynamics of an evacuation. These methods range from live simulations such as fire drills at schools to more computationally oriented solutions, including computer simulations and physics-based models that attempt to describe the movement of people during an evacuation in terms of fluid flows. Simulations range in scope from large-scale evacuations that attempt to answer how long it takes to evacuate an entire city to smaller-scale “micro” simulations that focus on individual actors and their behavior during an evacuation event. These micro simulations attempt to represent real-world behaviors of individuals or vehicles as they navigate through an evacuation area; the results highlight areas or situations that could hinder an evacuation process. While informative, these

simulations require considerable time and effort to set up properly, and the required level of programming to implement and test changes to the system can make it prohibitive to respond to emergent threat scenarios.

In this thesis, we develop a network flow model of an evacuation scenario and use optimization to quantify best-case evacuation behavior; we focus on the evacuation of the Mission Canyon neighborhood near Santa Barbara, California. We have chosen this neighborhood for several reasons. First, its location along an urban-wildland boundary combined with the history of wildfires in the adjacent Los Padres National Forest makes it a high-risk area for fires. Second, previous work by Cova and Church (1997) determined that the Mission Canyon neighborhood has a “high bulk-lane demand.” Defined as the total demand leaving a neighborhood compared to the number of lanes that leave the neighborhood, a *high bulk-lane demand area* that indicates quick evacuation may be difficult. Because this neighborhood is at-risk, Church and Sexton (2002) directed considerable effort to develop a micro simulation model of its evacuation; we believe this micro simulation model provides an excellent baseline against which to compare the results of our network flow model. While we do not assert that our model captures all the details in the micro simulation model, we believe that it captures the first-order evacuation behavior, such as congestion “hot spots” that could delay evacuation. We maintain that understanding this first-order behavior is critical for planning evacuations. Because we can quickly modify and solve the network flow model if conditions change (e.g., one road used for evacuation becomes blocked and cannot be used) it can be an important tool for emergency planners.

Chapter II of this thesis reviews previous attempts to model evacuation. In Chapter III, we present in detail our network flow model of evacuation. Chapter IV presents our analysis of the Mission Canyon neighborhood, and how the results compare to the previous micro simulation work. In Chapter V, we present our conclusions concerning the efficacy of our model, along with potential follow on work to improve the model.

II. LITERATURE REVIEW

Evacuation modeling has progressed from what essentially amounted to “best-guess estimates” into a wide and mature discipline. The level of detail of research has varied between large-scale city or county evacuations to small-scale building evacuations. This section briefly reviews some of the research most relevant to this study.

A. LARGE-SCALE EVACUATIONS

Evacuation research starts with the notion that an evacuation can be successful only when there is sufficient time for all affected individuals to reach safety. Building on the Federal Emergency Management Agency’s Hurricane Evacuation (HURREVAC) system (FEMA, 2000) for determining an evacuation radius in the event of a hurricane, Cova et al. (2005) argue that a similar system can be developed for fires or other smaller scale evacuations. Taking wind speed, available fuel, ground gradient, and other pertinent information as input, they develop a model that identifies “decision arcs” that can help emergency planners determine when an evacuation should be ordered, or when people should be told *not* to evacuate because the fire is too close. Using simulation, the authors are able to identify decision arcs that are not necessarily equidistant or uniform (as would be the case for hurricanes), and can be changed depending upon the varying input conditions. Their work informs our research by demonstrating the ability to model a complex evacuation decision process in a dynamic environment (Cova et al., 2005).

Li and Zhang (2009) assess whether an evacuation is feasible with a stochastic Markov process simulation of evacuee movement within a network as they travel from their origin to the designated “safe zone.” Each network node has an initial population and number of evacuation vehicles, and the simulation provides an expected distribution of evacuees over time. The authors conclude that their model informs decision makers about the adequacy of the transportation network to support an evacuation.

Lahmar et al. (2006) use a staged optimization process to determine optimal routes out of an evacuation zone. Using input from the Geographical Information System

(GIS), they consider a geographic region that encompasses the evacuation zone along with safe destinations that can be reached from this area. The authors divide up the evacuation zone by zip codes, and they estimate the population in each zip code as the product of the houses in the zip code and the average number of people per house. They place a node at the geographic center of each zip code, and use the associated population for that zip code as the supply at the node. Arcs represent all roads that connect one node to another, and they model safe regions as destination nodes. Arc costs for their model are the associated distance between nodes. By solving for the maximum passage of people during a specified time window, they determine whether it is feasible for a central authority to evacuate the total population. They argue that this method produces a lower bound on the amount of time needed to evacuate a given area, and that it helps to determine if the network is capable of supporting an evacuation if ordered.

B. SMALL SCALE EVACUATIONS

At the opposite end of the scale is the evacuation of relatively small areas, such as buildings or city blocks. Here, one typically assumes that evacuation is feasible, and the question is simply how long it will take.

Chalmet, Francis, and Saunders (1982) develop a network flow model of building evacuation. They take as inputs to the model: the number of people in the workspaces, the flow capacity of stairwells, halls, and lobbies, and the static capacity of all these areas. Using this information, they first built a static model of the building and then extend that model to account for time. They achieve this by duplicating each node in the static model once for each distinct time period and creating arcs that represent the movement of individuals in space and time. They use time-dependent arc costs along the exit-to-super-sink arcs, and solve for minimum cost flows to obtain minimum evacuation times. The output of their model presents optimum evacuation times and optimal route utilization (Chalmet et al., 1982).

Fahy (1995) also models building evacuation using a network; in this model, rooms and exits are nodes while hallways and stairwells are arcs. Starting with occupant data for each room and walking speeds of individuals, one solves the network flow model

to determine the movements and clearance times during an evacuation. By allowing the modeler to choose between the shortest routes or most familiar routes of evacuees, this model can represent both exit behaviors, and it shows as output such metrics as floor clearing times and how many people use each exit (Fahy, 1995).

Chiu and Zheng (2007) also use a time-step network flow model. Building on the cell transmission model of Daganzo (1994, 1995), the authors represent evacuation behavior as movement along the arcs that can be traveled by unimpeded traffic in one time period. They specify four different types of cells, each with a different equation that describes travel between those cells. They take as input the number of evacuating people from a region, as well as the region itself. They treat each of the applicable border nodes of the “hot zone” as a viable destination node, and they connect all of these nodes to an artificial sink node. In addition, they link all source nodes to an artificial source node. The resulting optimization identifies the number of time steps (and therefore the evacuation time) necessary to evacuate groups of different priorities, as well as the optimal routes that should be taken.

Liu et al. (2006) also build upon the work of Daganzo (1994, 1995). They develop a two-level integrated optimization, and perform follow-on simulation to compare their results. Using a modified cell transmission model consisting of general cells, source cells, and sink cells (each with different flow equations), their high-level optimization seeks to maximize vehicle throughput, while their low-level optimization seeks to minimize travel and waiting time for the evacuation. They report these attributes as outputs for the model, in addition to the routes that are used in the low-level optimization. The results, when compared to simulation, indicate that their approach is capable of effectively and efficiently generating a set of optimal emergency evacuation plans. This research builds on previous research by Liu et al. (2005), which seeks to develop a general framework for an emergency evacuation system.

C. OUR CONTRIBUTION IN CONTEXT

We model the evacuation of the Mission Canyon neighborhood using a space-time network flow representation, similar in concept to that of Chalmet et al. (1982) but for the entire neighborhood. Our model solves for “best case” evacuation routes and clearing times, as could be identified and implemented by a central authority. Our models are large, but we can solve them efficiently and quickly. By solving many model excursions, we can assess the importance of different model features as well as evaluate evacuation behavior for a variety of what-if scenarios. We apply our model to the evacuation of the Mission Canyon neighborhood and compare our results to the simulation-based study of Church and Sexton (2002).

III. MODEL FORMULATION

A. THE SPATIAL MODEL

We model the neighborhood evacuation as a single-commodity network flow optimization problem. We believe that modeling the problem in such a manner is comparably informative to the much more time intensive micro-simulation approaches often used to assess evacuation behavior. We use the Mission Canyon Neighborhood of Santa Barbara as our test neighborhood for two specific reasons. First, its proximity to large wooded areas and its limited number of egress routes make it a likely candidate to need rapid evacuation during wildfire emergencies. Second, Church and Sexton (2002) already modeled this neighborhood using a micro-scale traffic simulation model; the results of this prior micro-simulation provide a baseline against which we can measure the results we obtain. A picture of the neighborhood from that report appears in Figure 1.

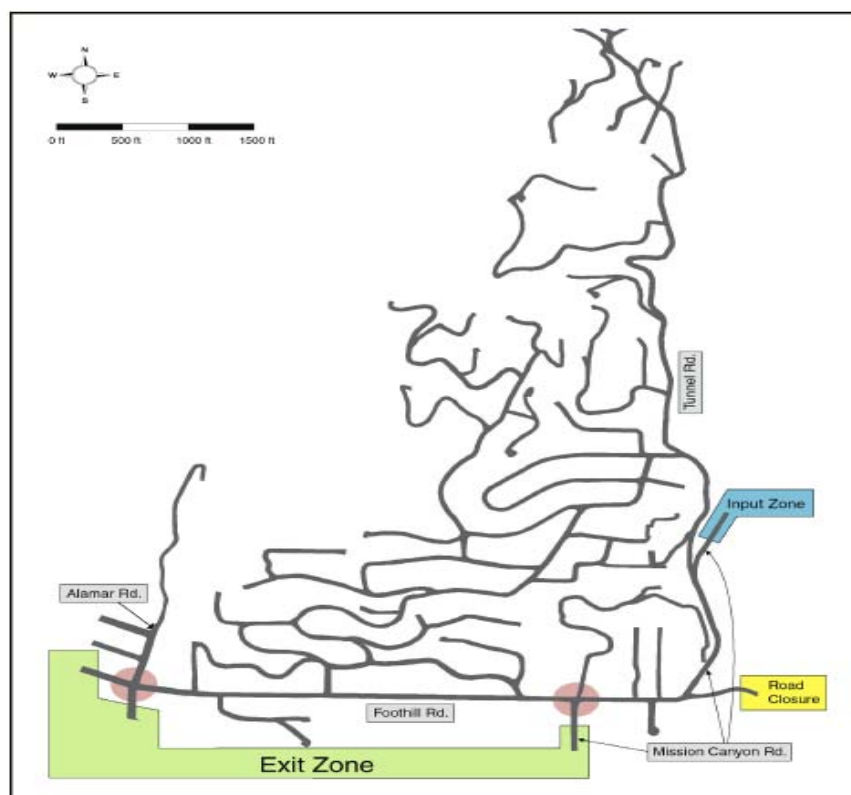

Figure 1. Mission Canyon neighborhood (From Church & Sexton, 2002). The picture shows the street network as well as the two egress points to the exit zone.

We use Google Earth to map out the road network. We segment the neighborhood roads into a series of arcs and nodes, separating long road segments into a series of arcs and “transshipment nodes” at intervals of approximately 264 feet (0.05 miles) apart. We represent each node with a placement marker available in the Google Earth software package. The markers allow us to individually label each node, and provide coordinate data that we use in displaying the network and running our optimization model. We then place nodes on the map overlay corresponding to the location of the houses (source nodes) within the neighborhood. We connect each house node to the closest corresponding node on the road network. We connect each house node to its adjacent road node using a single directed arc, and we connect adjacent road nodes using two directed arcs, one for each possible direction of travel along that road segment. We treat the points of egress in the neighborhood as the destination nodes for all traffic flow; if there is more than one egress we connect these nodes to a “super sink” node that has a demand equal to the sum total of all traffic in the region of interest. Figure 2 represents our spatial model for a simplified neighborhood.

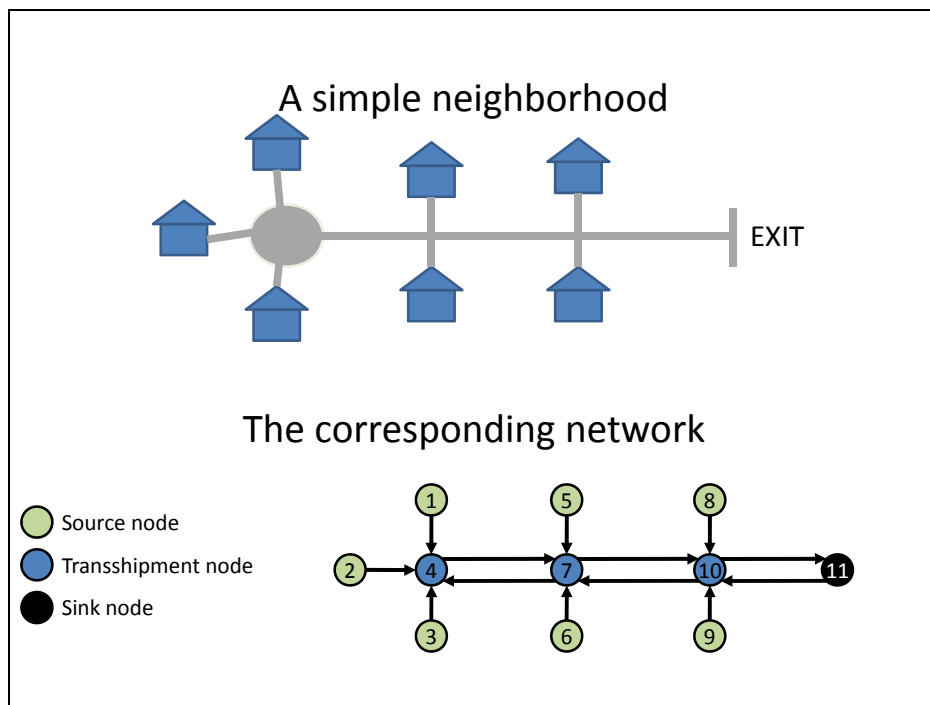

Figure 2. A simple neighborhood and its spatial network representation.

We modify the preliminary network by dividing it into regions and creating special intersection nodes. We split the Mission Canyon neighborhood into five distinct regions to help us visualize and quantify the flow dynamics through the neighborhood. We split each road intersection node into an inbound and outbound node connected by a single directed arc. This allows us to constrain the flow through intersections, as the intersections are likely to be bottlenecks during an evacuation event. Using the Google Earth picture as a guide, we next develop a list of nodes in the network and list of arcs connecting these nodes. The resulting data files are consistent with a forward-star matrix often used in network flow problems (Ahuja, Magnanti, & Orlin, 1993, p. 35).

We formulate the spatial minimum-cost network flow problem SPATIAL as follows.

Index Sets

$i \in L$

Locations (alias j)

$(i, j) \in A$

Directed arc from i to j

Data

$u_{i,j}$

Upper limit on arc (i, j)

$c_{i,j}$

Per-unit cost on arc (i, j)

b_i

Supply present at node (i)

Variables

$X_{i,j}$

Flow on arc (i, j)

Min-Cost Formulation

$$\min_X \quad \sum_{i,j} c_{i,j} X_{i,j} \quad (\text{C0})$$

$$s.t. \quad \sum_j X_{i,j} - \sum_j X_{j,i} = b_i \quad i \in L \quad (\text{C1})$$

$$X_{i,j} \leq u_{i,j} \quad (i,j) \in A \quad (\text{C2})$$

$$X_{i,j} \geq 0 \quad (i,j) \in A \quad (\text{C3})$$

The objective function value for our mathematical formulation (C0) aims to minimize the total cost of moving all supplies to a sink. Constraint (C1) ensures balance of flow at each node. Constraint (C2) ensures that flow along an arc does not exceed the capacity for that arc. Constraint (C3) ensures that there are no negative flows.

B. THE SPACE-TIME MODEL

Building on our spatial model, we develop a space-time model that replicates our spatial network in each of T time periods, and optimize the neighborhood evacuation based on time dependent arc costs assigned to those arcs that connect our egress points to our super-sink node. We incentivize movement by assigning a small cost to those arcs that represent remaining stationary in space-time, and assign zero arc costs to all other arcs throughout the network. The approach is as follows: For each time period t , we create an exact copy of all nodes in the network. We connect neighboring nodes from the spatial network with arcs that traverse a single time period (e.g., from t to $t+1$). In this network no supply ever remains stationary at one node. Although in actuality a vehicle may remain stationary between time periods t and $t+1$, they are moving through “space-time.” In other words, a car at node n that is stationary would move from node n at time t to node n at time $t+1$ in our model. By imposing an upper capacity limit on these “horizontal arcs,” we define a maximum amount of vehicles that can be held over at one node between time periods; if the inbound flow to a node exceeds its outbound arc capacity and its holding capacity, it forces that inbound flow to backup elsewhere in the

network. This structure allows us to model the buildup of traffic along a road segment during an evacuation. Figure 3 illustrates the time-space model as compared to the spatial model.

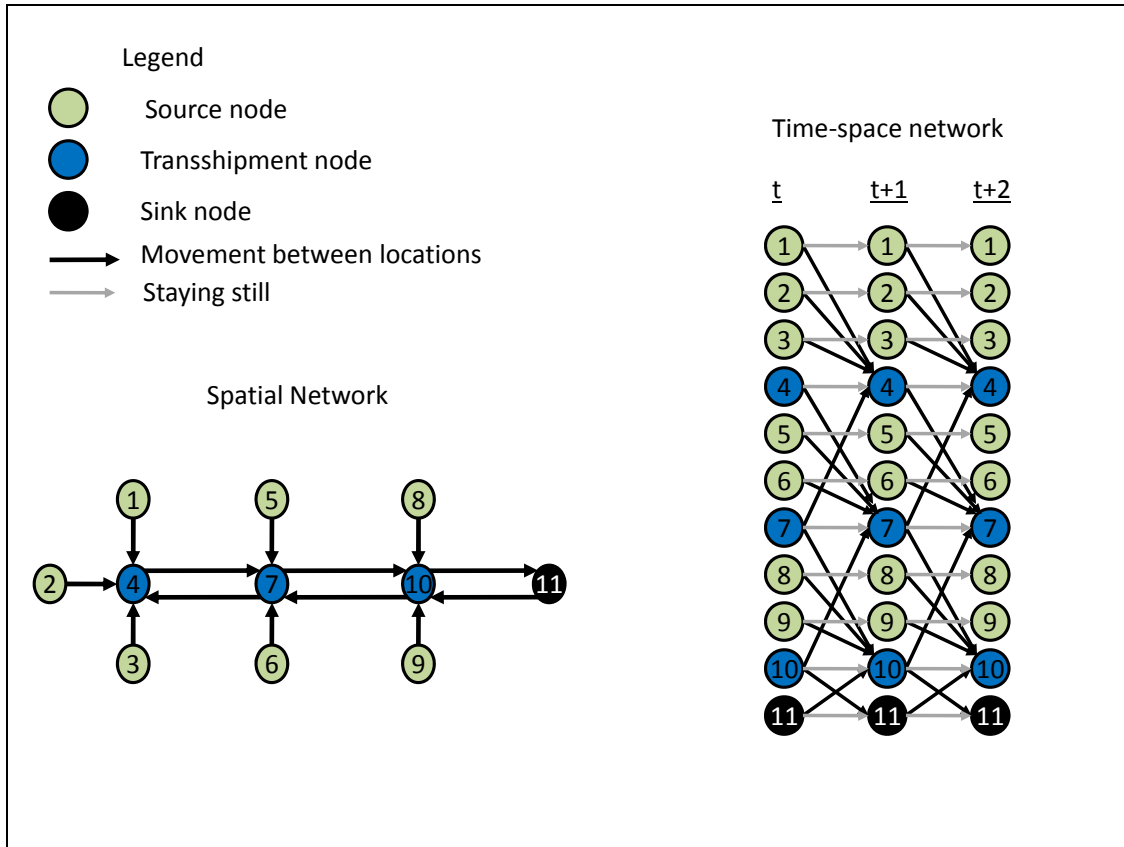

Figure 3. A simple spatial network and its representation in the space-time network.

We model the minimum cost evacuation behavior through time with formulation SPACETIME below.

Index Sets

$i \in L$

Locations (alias j)

$t \in T$

Time Periods (alias tp)

$(i, t) \in N$

Nodes $N=L \times T$

$(i, t, j, tp) \in A$

Arc from (i, t) to (j, tp)

$(i, t) \in S$

Sink Flows from location i in time t

Data

$bb_{i,t}$

Supply at node i at time t

$uu_{i,t,j,tp}$

Upper limit on arc (i, t, j, tp)

$cc_{i,t,j,tp}$

Per-unit cost on arc (i, t, j, tp)

Variables

$XX_{i,t,j,tp}$

Flow on arc (i, t, j, tp)

$WW_{i,t}$

Flow to sink from location i in period t

Min-Cost Formulation

$$\min_X \sum_{(i,t,j,tp) \in A} cc_{i,t,j,tp} XX_{i,t,j,tp} + \sum_{(i,t) \in S} t WW_{i,t} \quad (Q0)$$

$$s.t. \quad \sum_j XX_{i,t,j,t+1} - \sum_j XX_{j,t-1,i,t} + WW_{i,t} = bb_{i,t} \quad i \in L; 0 < t < T \quad (Q1a)$$

$$\sum_j XX_{i,t,j,t+1} + WW_{i,t} = bb_{i,t} \quad i \in L; t = 0 \quad (Q1b)$$

$$- \sum_j XX_{j,t-1,i,t} + WW_{i,t} = bb_{i,t} \quad i \in L; t = T \quad (Q1c)$$

$$XX_{i,t,j,tp} \leq uu_{i,t,j,tp} \quad (i, t, j, tp) \in A \quad (Q2)$$

$$XX_{i,t,j,tp} \geq 0 \quad (i, t, j, tp) \in A \quad (Q3)$$

In the above formulation, the objective function (Q0) is an intermediate calculation we use to determine the minimum evacuation time for the Mission Canyon neighborhood. The first term represents the cost of flow movement through the space-time network, and the second term is a weighted sum of sink flows. For our model, we assign an arc cost of zero to all movement arcs in the actual network that do not flow into the sink. We assign a minimal cost to arcs that represent remaining stationary to incent movement throughout the network. Additional costs are incurred when flow passes out of the real network into our artificial sink node. For simplicity, we assign to these arcs a

cost that increases with the time period in which the flow occurs (i.e., one unit of flow to the sink node at $t=3$ incurs a cost of three, while one unit of flow at $t=4$ incurs a cost of four, etc.). Minimizing this objective means getting all flows to the sink as soon as possible. The objective function value itself does not tell us much about minimum time to evacuate; however, we can recover clearing time by looking at sink flows.

The first three constraints are balance of flow constraints. Constraint (Q1a) ensures that the initial supply at a node plus any incoming supply at that node for time period t is equal to the supply remaining plus any flow from that node at time $t+1$; this constraint does not address the first and last time period. Constraint (Q1b) is the balance of flow constraint for the first time period, $t=0$. This constraint ensures that all supply initially present at a node (i) in time period $t=0$ is accounted for as flow to other nodes (j) at $t=1$. Constraint (Q1c) ensures that we account for all available supply by the final time period $t=T$.

Constraint (Q2) is a capacity constraint on the arcs in the network; it ensures that we do not have a greater volume of flow on any particular arc than the maximum capacity of that arc. Constraint (Q3) is a non-negativity constraint and ensures that there are no negative flows.

C. THE MISSION CANYON EXAMPLE

We apply model SPACETIME to the Mission Canyon neighborhood. We use a time step interval of 10 seconds, which is the approximate time it takes for an unimpeded car to travel over an arc segment of length 264 feet (0.05 miles). We base this interval on a maximum sustainable speed through the neighborhood of approximately 22 miles per hour (Church, 2010), which corresponds to approximately 3 minutes to travel a mile. Furthermore, we assume arc capacities of five vehicles for all transshipment nodes within our network. We base this arc capacity on an average vehicle length of approximately 17 feet, and assuming that an average vehicle will take up approximately 50 feet of road, including spacing between vehicles. Essentially, all of the roads in Mission Canyon are two-lane roads, and we do not attempt to model either contraflow scenarios or traffic control scenarios. In addition to being able to support five vehicles traveling along an arc, we assign a “holding capacity” of five vehicles per node, which translates to

horizontal arc capacities of five vehicles. We assign varying capacities to the different intersection arcs based on their traffic throughput capacities (Church, 2010), and we designate two distinct nodes in our network as sink nodes; our designation corresponds to the intersection Church and Sexton (2002) identified as being exit points for the neighborhood. Figure 4 and Table 1 reflect these details.

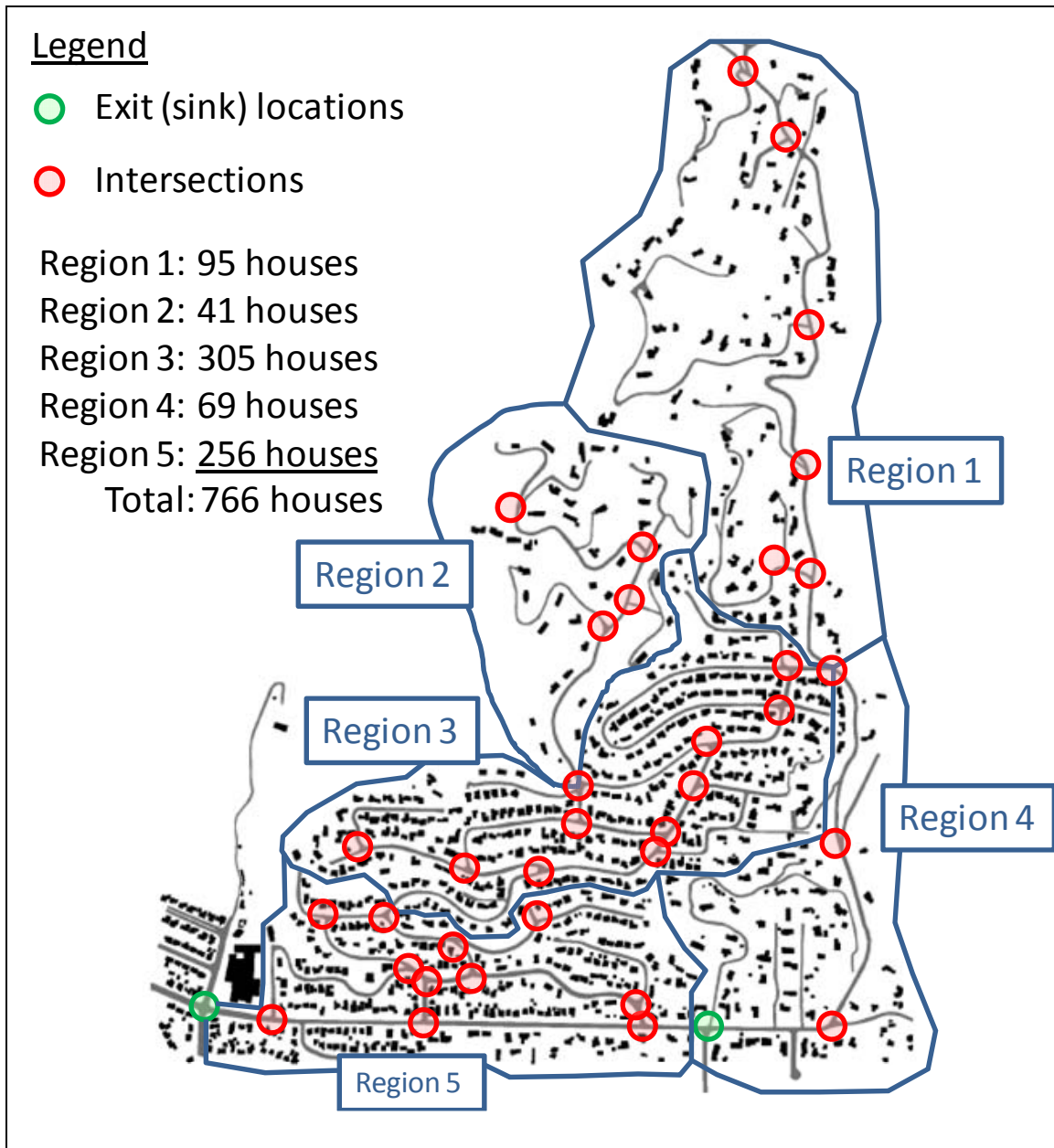

Figure 4. The Mission Canyon neighborhood with intersections and sink nodes identified. (After Church & Sexton, 2002).

Intersection Name	Node Name	Throughput Capacity estimate (cars/hr)*	Throughput per Time Period	Modeled Throughput
1. Ben Lomond and Williams	BEN01	1000	2.8	3
2. Kenmore and Ben Lomond	BEN06	750	2.1	2
3. Cheltenham and Dorking (North)	CHEL01	750	2.1	2
4. Cheltenham and Dorking (South)	CHEL03	750	2.1	2
5. Kenmore and Cheltenham	CHEL06	750	2.1	2
6. Cheltenham and Exeter(North)	CHEL12	750	2.1	2
7. Cheltenham and Selwyn	CHEL13	750	2.1	2
8. Cheltenham and Glen Albyn	CHEL16	750	2.1	2
9. Cheltenham and Tye	CHEL17	900	2.5	3
10. Cheltenham and Exeter(South)	CHEL18	750	2.1	2
11. Windsor and Cheltenham	CHEL23	750	2.1	2
12. Cheltenham and Foothill	CHEL24	1250	3.5	4
13. Exeter and Exeter Place	EX02	1000	2.8	3
14. Tunnel and Mission	FOO01	1200	3.3	4
15. Glen Albyn and Foothill	Gle07in	1200	3.3	4
16. Kenmore and Arriba	KEN04	750	2.1	2
17. Montrose and Cheltenham	MONTROSE01	1000	2.8	3
18. Williams and Palomino	PALOMINO16	850	2.4	3
19. Montrose and Tunnel	TUNNEL24	850	2.4	3
20. Tye and Foothill	TYE01	1200	3.3	4
21. Williams and Cheltenham	WILLIAMS03	1000	2.8	3

* Church (2010)

Table 1. Critical intersections of the Mission Canyon neighborhood. Using the estimated throughput capacities (in hourly vehicle flow) from Church (2010), we obtain an assumed flow capacity per time period (10-second interval). We use integer throughput for our model because it produces integer results (due to unimodularity). Our model is robust enough that throughputs could be non-integer data, with the understanding that the output would need to be interpreted in an aggregate manner.

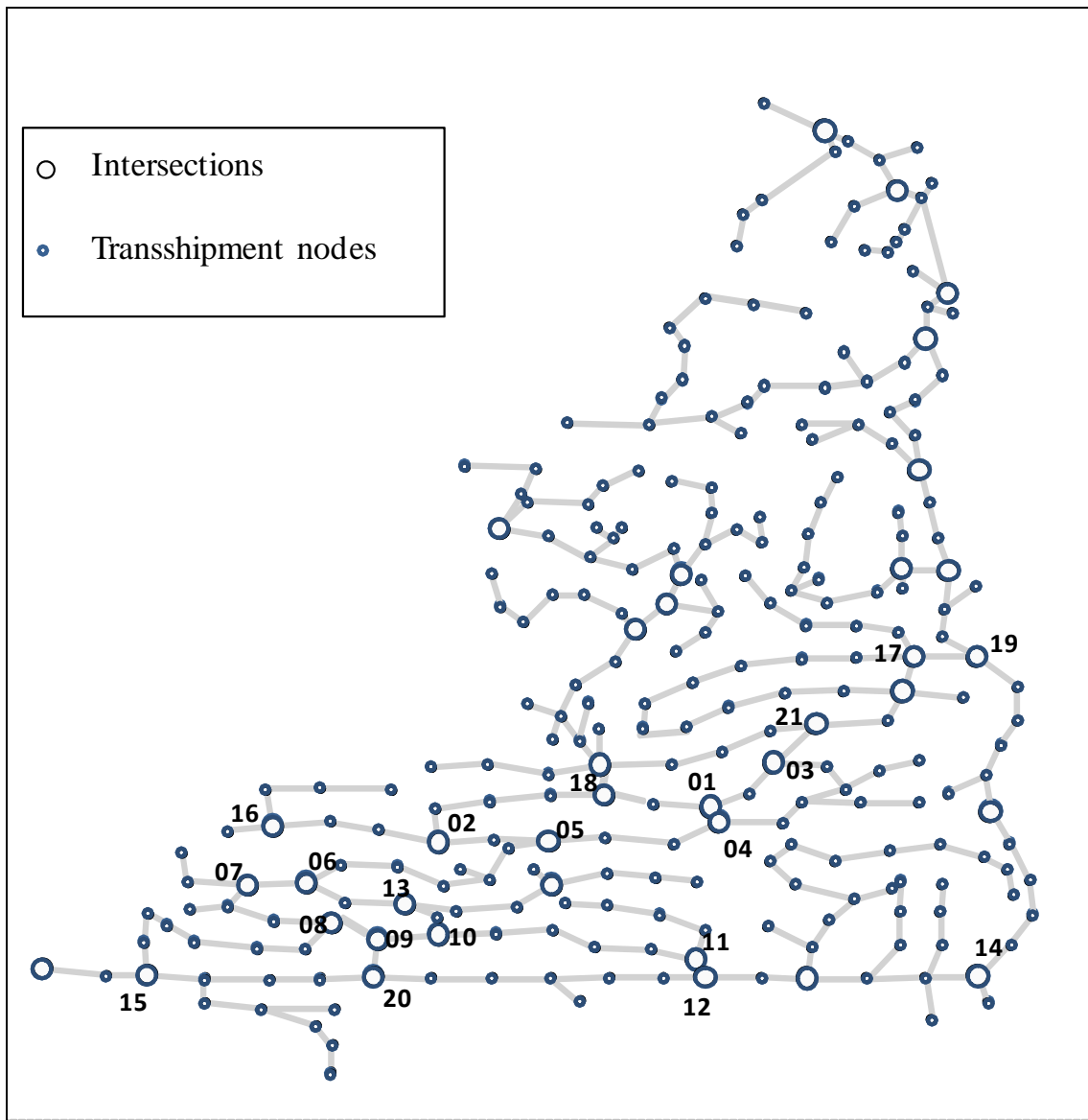

Figure 5. Network Representation of the Mission Canyon neighborhood with each of the 21 critical intersections labeled. See Table 1 for corresponding intersection names.

IV. RESULTS

A. DETERMINING A BASELINE

We first consider the scenario in which one car per household needs to evacuate from the Mission Canyon neighborhood. To be consistent with the previous work done by Church and Sexton (2002), we assume that 30% of all evacuating vehicles leave at $t=1$, 50% of vehicles begin to evacuate after five minutes ($t=30$), and 20% of vehicles begin to evacuate after 10 minutes ($t=60$). Under this scenario, it takes 18 minutes and 10 seconds (denoted as 18:10) for all vehicles to completely evacuate the neighborhood. Figure 6 shows the cumulative number of vehicles that evacuate through each of the sink nodes. Figure 7 shows the number of cars in each of the five regions throughout the evacuation scenario.

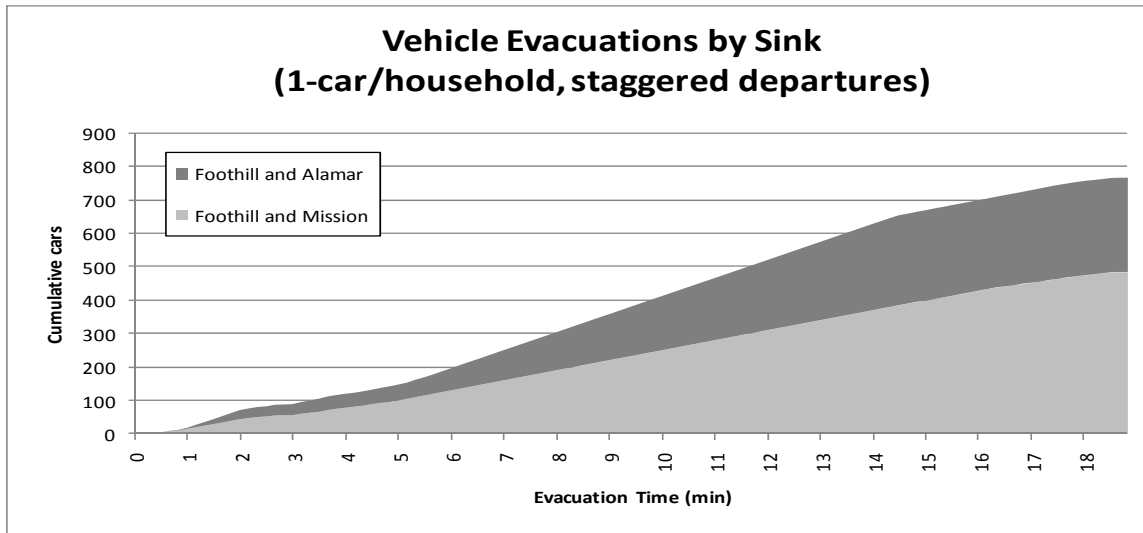

Figure 6. Cumulative vehicle evacuation by exit location (one vehicle per driveway).

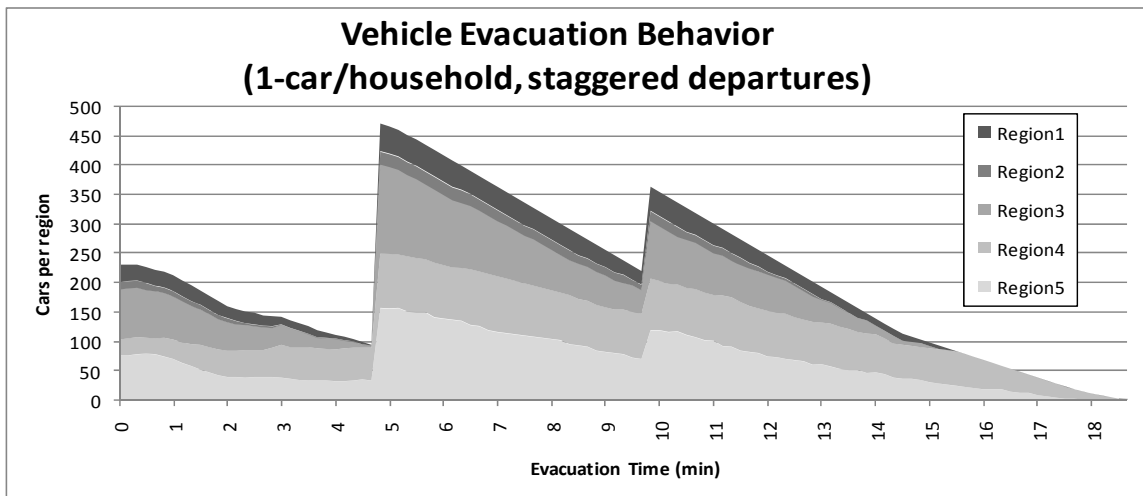

Figure 7. Vehicle clearing times and distribution by region (one vehicle per driveway). The shaded portion of the graph shows the number of vehicles in each region as a function of time. Note that a vehicle leaving one region may have to enter another region before exiting the neighborhood (e.g., vehicles leaving Region 1 must enter Region 4 before exiting).

We next consider the scenario in which two vehicles per household must evacuate the neighborhood, all of which follow the same staggered departures as with the one car scenario. We find that doubling the number of vehicles nearly double the clearing time; for two vehicles per household it takes 33:10 to completely evacuate the neighborhood. Figure 8 shows the cumulative evacuations through each of the sink nodes. Figure 9 shows the number of cars in each of the five regions throughout the two car evacuation.

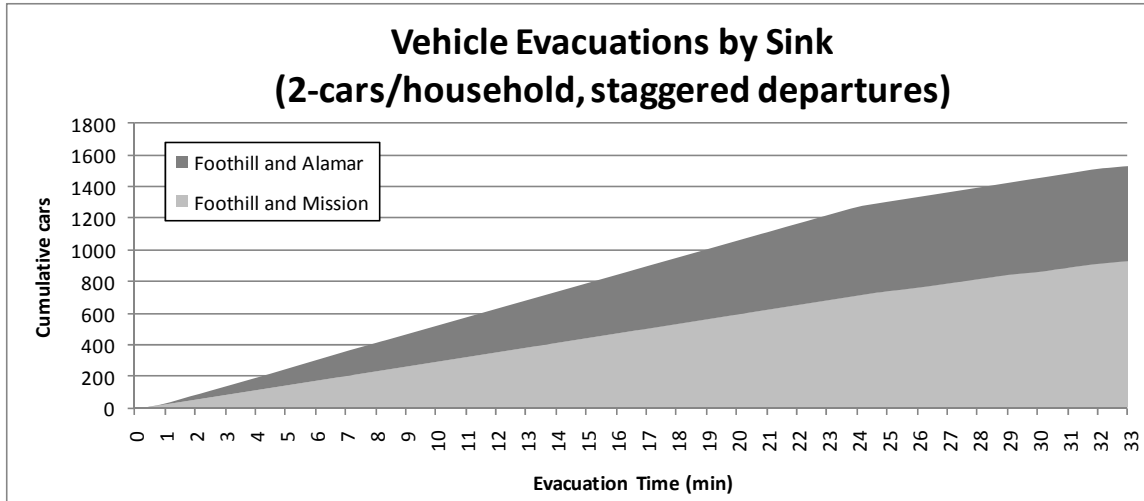

Figure 8. Cumulative vehicle evacuation by exit location (two vehicles per driveway).

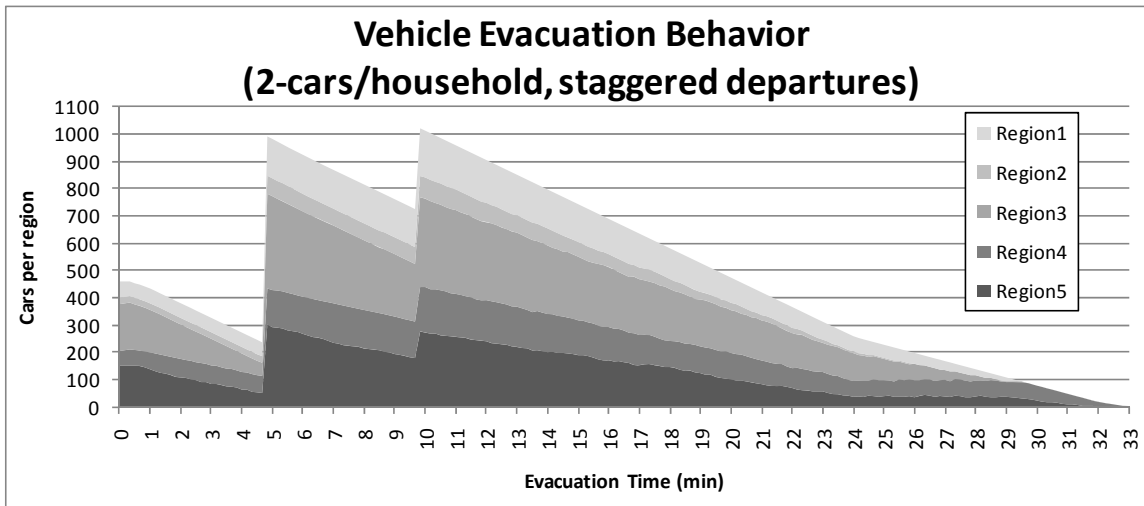

Figure 9. Vehicle clearing times and distribution by region (two vehicle per driveway).

We observe that the clearance times obtained from our network-flow model are consistent with the results from the micro-simulation model of Church and Sexton (2002). Assuming one car per driveway, they estimate that it takes 18:49 for all vehicles to evacuate, our model estimates that 18:50 would be required. Similarly, their model estimates that it would take 34:50 to evacuate all vehicles under a two car per driveway scenario, while our optimization model estimates a total time of 33:10 to evacuate the vehicles. Considering the level of agreement between the predicted clearance times these two models produce, we consider our optimization model to be valid, relative to their simulation model. Table 2 presents full results and a comparison to the Church and Sexton (2002) micro-simulation model, referred to as the “Vital Report.”

		Vital Report		Staggered SPACETIME Foothill flow =5		Staggered SPACETIME Foothill flow =10		No Stagger SPACETIME Foothill flow =5		No stagger SPACETIME Foothill flow =10	
		1 car/house	2 cars/house	1 car/house	2 car/house	1 car/house	2 car/house	1 car/house	2 car/house	1 car/house	2 car/house
total cars		763	1526	766	1532	766	1532	766	1532	766	1532
% of cars	50%	8:23	15:43	9:40	14:50	8:30	11:40	7:40	14:40	6:00	10:30
	75%	12:04	24:16	13:10	21:50	12:30	20:00	11:30	21:50	11:30	19:50
	90%	15:28	30:25	15:50	27:40	16:00	27:40	15:20	27:30	15:20	27:30
	95%	16:44	32:40	17:10	30:10	17:10	30:20	16:40	30:00	16:40	30:10
	100%	18:49	34:58	18:50	33:10	18:50	33:10	18:10	33:00	18:10	33:00
# of cars	200	4:57	4:43	6:20	4:20	6:00	3:50	4:20	4:10	3:20	3:00
	400	9:14	8:47	10:00	8:00	8:50	7:00	8:00	8:00	6:20	5:20
	600	13:41	12:59	13:40	11:40	13:10	9:30	12:20	11:40	12:20	8:00
	800		16:55		15:20		12:10		15:20		11:00
	1000		21:54		19:10		15:10		19:00		15:00
	1200		26:53		22:50		21:40		22:40		21:40
	1400		32:45		28:20		28:20		28:10		28:20

Table 2. Comparison of clearance times for the Vital Report and for the staggered and simultaneous departure scenarios of our model.

B. DOES STAGGERING MATTER?

Having established a baseline for our evacuation model, we now ask how much of an impact the assumed staggered departures have on the total time to evacuate the neighborhood. To determine whether there is an effect, we modify our model so that all vehicles begin to evacuate at $t=1$. Under this scenario, our model estimates a clearing time of 18:10 to evacuate the neighborhood assuming one car per driveway, compared to 18:50 if we stagger the departure times. The results for two cars per household assuming a simultaneous evacuation indicate a clearing time of 33:00, compared to 33:10 if we stagger the departure time.

These results suggest that staggering the departure times has essentially no impact on the total time to evacuate the neighborhood. This implies that the road network is near its limit for clearing capacity in either scenario. Figure 10 shows the number of cars in each of the five regions, for the one-car-per-house scenario during a staggered evacuation, and during a simultaneous evacuation. Figure 11 shows the number of cars in each of the five regions, for the two-car-per-house scenario, during a staggered evacuation, and during a simultaneous evacuation.

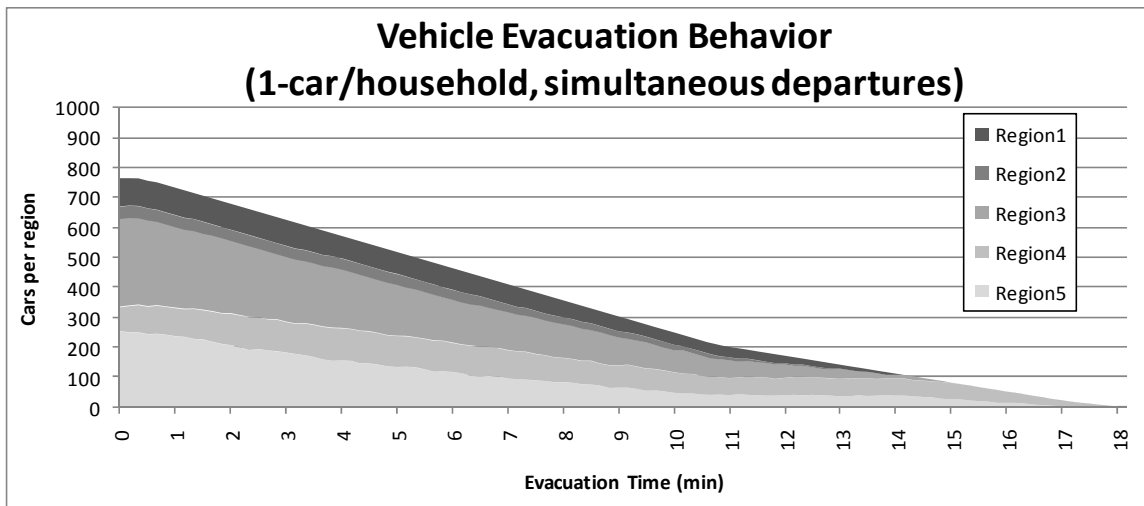
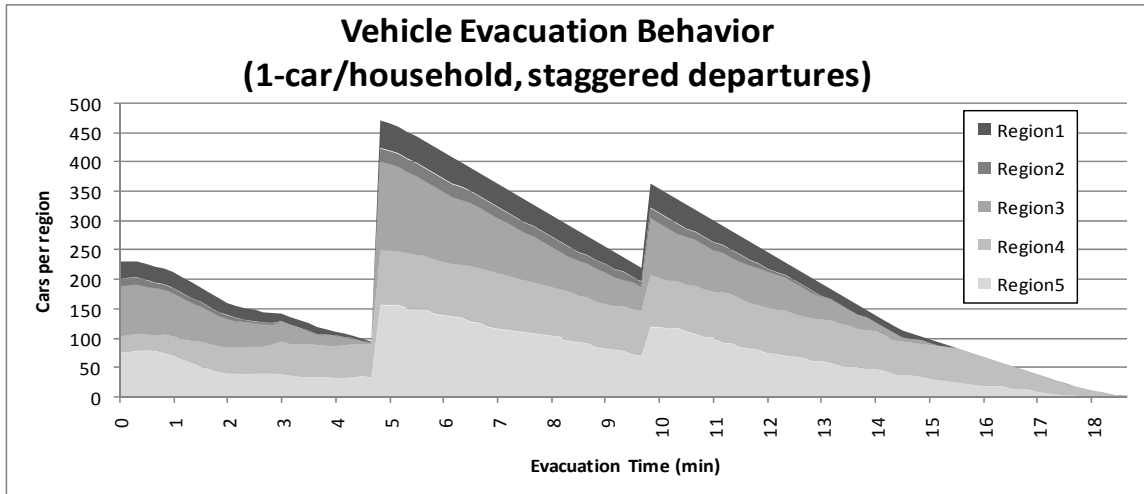

Figure 10. Clearing times by region, staggered departures (top), simultaneous departures (bottom). Note the staggered departure case repeats Figure 7.

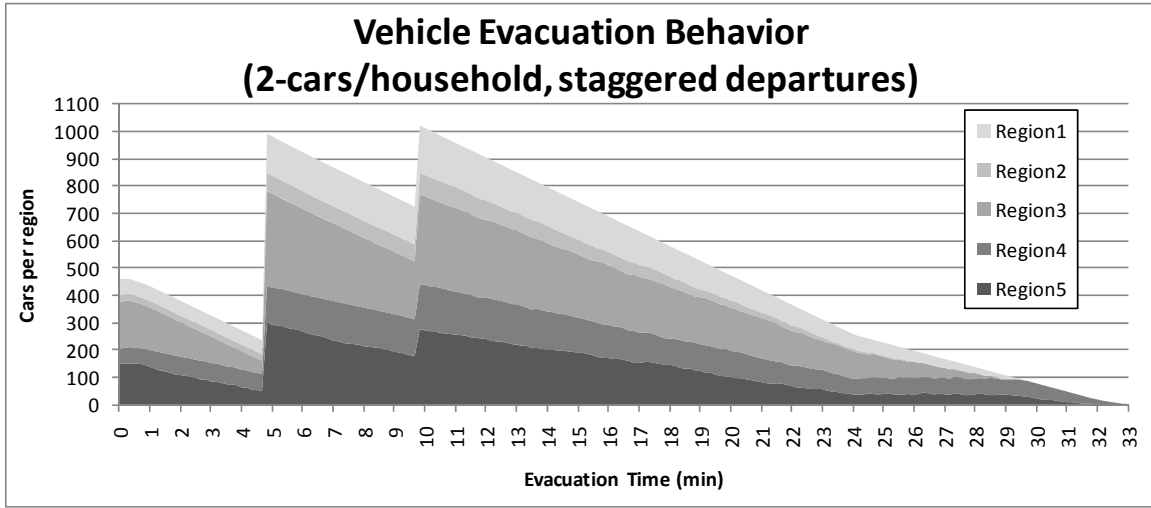

Figure 11. Clearing times by region, staggered departure (top), simultaneous departure (bottom). Note that the staggered departure case repeats Figure 9.

C. THE IMPORTANCE OF FOOTHILL ROAD

1. Reduction in Throughput Capacity

We next consider whether or not the presence of “background” traffic along Foothill Road has an effect on the total amount of time it takes to evacuate the Mission Canyon neighborhood. All neighborhood traffic must travel on Foothill Road in order to evacuate the neighborhood, but there can also be significant traffic on it from surrounding neighborhoods. Thus, there is potential for existing traffic to impede the evacuation. We consider this by running a number of model excursions in which we vary the capacity of the arcs that coincide with Foothill Road. We focus these experiments on the two car staggered baseline scenario, since we believe that any potential problems with evacuation will be more obvious with the greater number of cars on the road.

Foothill Road Status	Clear Time	Increase Over Baseline
arc capacity=1	2:08:40	1:35:30
arc capacity=2	1:05:10	32:00
arc capacity=3	43:50	10:40
arc capacity=4	33:10	-
arc capacity=5	33:10	-
arc capacity=10	33:10	-
arc capacity=15	33:10	-
arc capacity=50	33:10	-
Loss of Foothill/Mission egress	1:04:30	31:20
Loss of Foothill/Alamar egress	51:40	18:30

Table 3. Results of varying vehicle capacity and egress routes along Foothill Road.

Table 3 summarizes the results. We find that as long as there is capacity of four vehicles per time period (1440 per hour), then there is no impact on clearing times. Recall that our baseline assumes five vehicles per time period.

Decreases below four vehicles per time period on Foothill Road affect the clearing times for Mission Canyon. If the arc capacity is only one vehicle per time period (360 per hour), it takes 2:08:40 to evacuate the neighborhood, or 1:35:30 longer than our

baseline scenario. An arc capacity of two vehicles per time period (720 per hour) requires an additional 32:00 over the baseline to clear the neighborhood, while an arc capacity of three vehicles per time period (1080 per hour) requires an additional 10:40 to clear. Increases in capacity above the baseline (up to 50 cars per time period) yield no improvement in clearing times.

Like the other roads in Mission Canyon, Foothill Road is a two-lane road; however, this road can support vehicles at higher speeds and has a higher speed limit. Based on posted speed limits, we conservatively estimate that Foothill Road has a capacity of eight vehicles per time period (2880 vehicles per hour). Thus, as long as there is approximately 50% of free-flow capacity (1400 vehicles per hour) on Foothill Road during an evacuation, the presence of background traffic does not impact the clearing time of the Mission Canyon neighborhood; rather, it is the road network of the neighborhood itself that is the limiting factor during an evacuation. There are a number of intersections in the Mission Canyon neighborhood that have a low throughput capacity, and many of these fall along the main routes out of the neighborhood. These restrictive intersections have a greater impact on how long it takes to evacuate the neighborhood than the presence of traffic on Foothill Road.

2. Loss of an Egress Point

We also consider the impact of losing an egress point by changing the quantity of sink nodes and estimating how much longer it will take to evacuate the neighborhood. By removing the Foothill Road and Mission Canyon Drive intersection as a point of egress, it takes 64:30 to evacuate, an increase of 31:20 over our baseline scenario. Removing the Foothill Road and Alamar Avenue intersection as a point of egress it takes 51:40 to evacuate Mission Canyon, an increase of 18:30 minutes from our baseline scenario. These results also appear in Table 3.

D. IMPACT OF ROAD OR INTERSECTION CLOSURES

We now consider the impact of closing roads and intersections in the Mission Canyon neighborhood on evacuation behavior.

1. Varying the Flow Along Tunnel Road

Tunnel Road runs along the side of the lower Mission Canyon neighborhood, serving as the single egress route for the upper portion of the neighborhood, and one of two main egress routes for the middle portion of the neighborhood. We consider what impact closing the lower portion of the road (below the point of entry for middle Mission Canyon) would have on the overall evacuation time. To assess this, we set the arc capacity of the segment connecting Tunnel Road to Foothill Road (Tunnel33 in our model) to zero. For the one car scenario, the closure of this arc results in a clearing time of 41:10, or 22:20 longer than our baseline model. In fact, losing this egress route results in a longer clearing time than what would be required for the two-car scenario if the arc remained open and at its baseline capacity. Closing this arc in our two-car scenarios results in a clearance time of 1:18:10, or 45 minutes longer than the time required for our baseline model.

We also consider the effect of closing Tunnel Road near the point of entry for middle Mission Canyon (Tunnel24 in our model). Doing so results in clearing times that are nearly identical to those we obtain by closing the road near the entry to Foothill Road. These results clearly indicate that this segment of road is crucial to a quick evacuation of the Mission Canyon neighborhood. Figure 12 shows the location of Tunnel Road, as well as the two intersections we “close.”

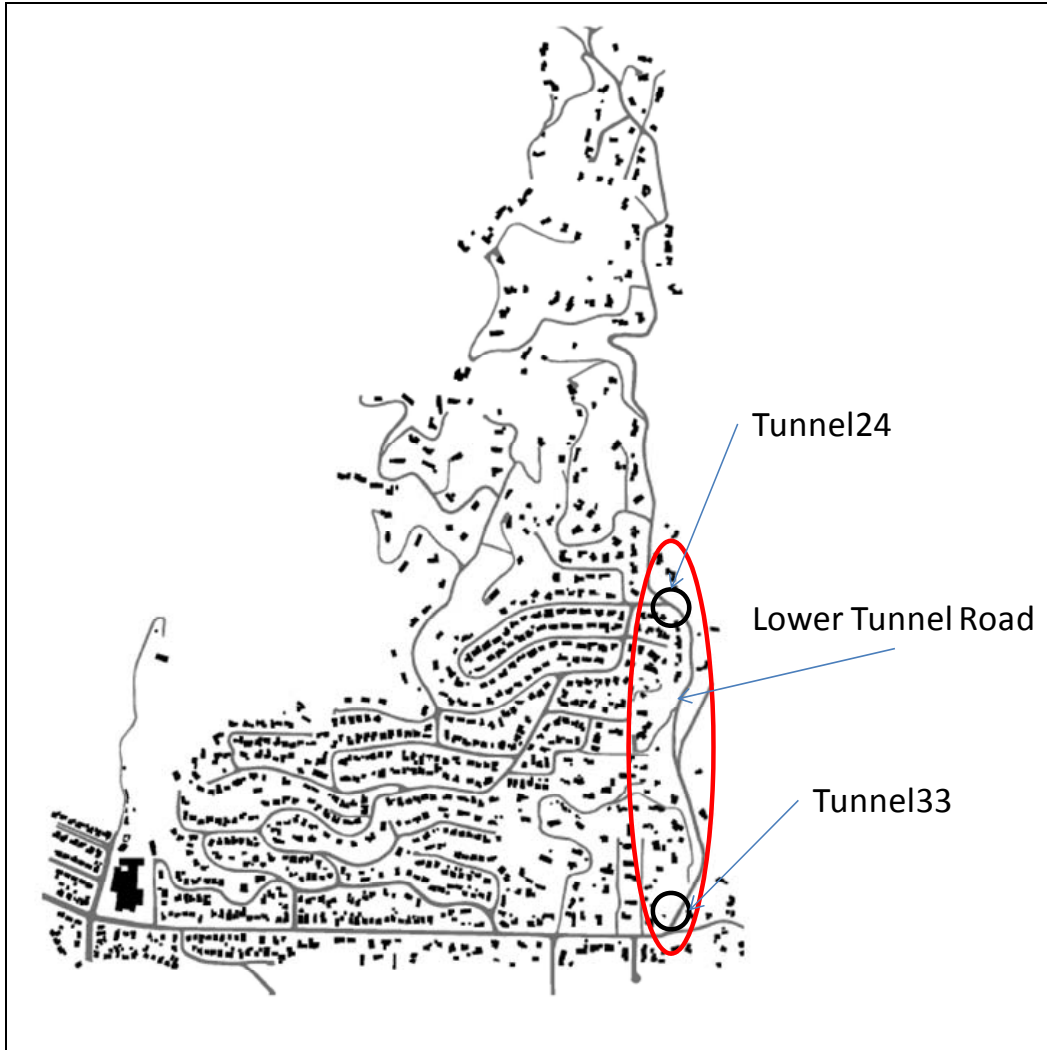

Figure 12. The Mission Canyon Neighborhood with lower Tunnel Road highlighted (After Church & Sexton, 2002).

Because of the importance of this road on the evacuation of the Mission Canyon neighborhood, we now consider how the evacuation would change if we could somehow increase the carrying capacity of this segment of the network. For example, we could increase the carrying capacity of this road segment, if we use both lanes of the road for egress; this is known as *contraflow traffic control*. We study this by increasing the carrying capacity for all arcs along this segment of road from five cars per time period (our baseline) to ten cars per time period. For both the one- and two-car scenarios, this change yields no estimated improvement in clearing time of the Mission Canyon neighborhood, due to a limiting effect that Foothill Road now has on the network.

However, by also increasing the arc capacity along Foothill Road to ten cars per time period, we do see some improvement in clearing times. The one car scenario sees only a modest 0:30 improvement in clearing times when we model for contraflow along Tunnel and increased flow along Foothill Road. The two-car scenario sees a more significant improvement in evacuation times, however, decreasing from 33:10 to 26:30, lowering the evacuation time by 6:40 minutes. Based on this, we believe that the evacuation of Mission Canyon could be improved by utilizing a combination of contraflow traffic routing along Tunnel Road and limiting the non-evacuation traffic along Foothill Road, thereby allowing for greater evacuation traffic flow. We present full results for these model excursions in Table 4 and Table 5.

Intersection and Capacity	Clearance Time with Foothill Capacity=5	Clearance Time with Foothill Capacity=10
Tunnel33 capacity=0	41:10	41:10
Tunnel 33 capacity=1	30:10	30:10
Tunnel 33 capacity=2	22:30	22:30
Tunnel 33 capacity=3	18:50	18:50
Tunnel 33 capacity=4	18:50	18:50
Tunnel 33 capacity=5 (Baseline value)	18:50	18:50
Tunnel 33 capacity=6	18:50	18:50
Tunnel 33 capacity=10	18:50	18:50
<hr/>		
Tunnel24 capacity=0	40:30	40:30
Tunnel24 capacity=1	30:00	30:00
Tunnel24 capacity=2	22:30	22:30
Tunnel24 capacity=3 (Baseline value)	18:50	18:50
Tunnel24 capacity=4	18:50	18:50
Tunnel24 capacity=5	18:50	18:50
Tunnel24 capacity=6	18:50	18:50
<hr/>		
all lower Tunnel capacity=5	18:50	18:50
all lower Tunnel capacity=6	18:50	18:50
all lower Tunnel capacity=7	18:50	18:50
all lower Tunnel capacity=8	18:50	18:50
all lower Tunnel capacity=10	18:50	18:50

Table 4. Impact of Tunnel Road capacities on clearance times. One car per driveway with staggered departure times. Increasing capacity of Tunnel Road and Foothill Road does not improve evacuation clearing times.

Intersection and Capacity	Clearance Time with Foothill Flow=5	Clearance Time with Foothill Flow=10
Tunnel33 capacity=0	1:18:10	1:18:10
Tunnel 33 capacity=1	55:20	55:20
Tunnel 33 capacity=2	40:50	40:50
Tunnel 33 capacity=3	33:20	33:20
Tunnel 33 capacity=4	33:10	33:10
Tunnel 33 capacity=5 (Baseline value)	33:10	33:10
Tunnel 33 capacity=6	33:10	33:10
Tunnel 33 capacity=10	33:10	33:10
<hr/>		
Tunnel24 capacity=0	1:17:00	1:17:00
Tunnel24 capacity=1	54:50	54:50
Tunnel24 capacity=2	40:40	40:40
Tunnel24 capacity=3 (Baseline value)	33:10	33:10
Tunnel24 capacity=4	33:10	28:10
Tunnel24 capacity=5	33:10	26:40
Tunnel24 capacity=6	33:10	26:40
<hr/>		
all lower Tunnel capacity=5	33:10	26:40
all lower Tunnel capacity=6	33:10	26:30
all lower Tunnel capacity=7	33:10	26:40
all lower Tunnel capacity=8	33:10	26:40
all lower Tunnel capacity=10	33:10	26:30

Table 5. Impact of Tunnel Road capacities on clearance times. Two cars per driveway with staggered departure times. Increasing capacity of Tunnel Road and Foothill Road improves evacuation clearance times.

2. Impact of Road Closures

We now consider the role of 21 “critical intersections” (Church, 2010) for the Mission Canyon neighborhood. We first look at what happens to the evacuation times if an intersection is completely blocked. Such a scenario could arise due to a natural calamity (e.g., a tree falling or reduced visibility, causing an accident that blocks the road) or due to the actions of an intelligent adversary (e.g., a person intentionally obstructs an intersection with a large vehicle). Of the 21 intersections, we find that eight of them, if blocked individually, would completely isolate some houses. The most severe of these is the Montrose and Tunnel intersection, which connects the entire upper region

of Mission Canyon, 95 homes in total. In addition to isolating 95 homes, a closure of this intersection increases the overall time to evacuate the rest of the neighborhood (assuming 2 cars per driveway) by 27:30. The loss of the intersection at Montrose and Williams would also be disastrous for evacuation times. Losing this intersection isolates 14 homes from the evacuation network and increases the time to evacuate the remaining neighborhood (assuming two cars per driveway) by 25:20. As previously mentioned, a loss of the intersection at Tunnel and Foothill (Tunnel 33) increases evacuation time by 45:00, although it does not isolate any homes.

Losing the intersection of Palomino and Williams isolates 51 homes, but results in an improvement in evacuation time for the remaining homes relative to our baseline model (3:50 faster). Assuming two cars per driveway, this closure removes 102 cars from the system, and this explains why we see an improvement in evacuation time. Similar results hold for the intersection of Ben Lomond and Kenmore; 47 homes are isolated, but evacuation time for the remaining neighborhood is improved by 2:50. Losing the intersection of Kenmore and Arriba isolates 31 homes and results in an improved evacuation time for the remaining neighborhood of 2:00.

Table 6 summarizes the impact of these and other intersection closures on the number of isolated houses and the total clearing times. Intersections whose losses would isolate houses are natural candidates for traffic control or other “protection measures.” Figure 14 illustrates the locations of these intersections in the Mission Canyon neighborhood.

2 Car staggered network- variation results					
Intersection	Houses isolated if intersection is "closed"	clearing time for remaining houses (periods)	Δt (minutes)	Clearing time if intersection arc capacity=1 (periods)	Δt (minutes)
1. Ben01	-	199	-	199	-
2. Ben06	47	182	-2:50	199	-
3. Che01	-	199	-	199	-
4. Che03	-	199	-	199	-
5. Che06	-	294	15:50	229	5:00
6. Che12	-	310	18:30	241	7:00
7. Che13	10	213	2:20	199	-
8. Che16	-	224	4:10	199	-
9. Che17	-	199	-	199	-
10. Che18	-	221	3:40	199	-
11. Che23	21	199	-	199	-
12. Che24	-	210	1:50	199	-
13. Ex02	21	210	1:50	199	-
14. Foo01	-	469	45:00	332	22:10
15. Gle07 *	-	307	18:00	258	9:50
16. Ken04	31	187	-2:00	199	-
17. Montrose01	14	351	25:20	254	9:10
18. Palomino16	51	176	-3:50	199	-
19. Tunnel24	95	364	27:30	329	21:40
20. Tye01	-	204	0:50	199	-
21. Williams03	-	278	13:10	200	0:10
* (closing isolates Foo15 sink)					

Table 6. Effects of intersection closures or restrictions on the evacuation of Mission Canyon.

3. Impact of Severely Limiting Intersection Flow

We also consider the impact of severely limiting the throughput capacity at these 21 critical intersections. We assess this by reducing in isolation each intersection capacity to one vehicle per time period (360/hour). Doing so, we find that a number of these intersections are not critical, provided that they have minimal throughput capacity. In fact, six of the eight intersections that isolate homes when blocked have no impact on clearing times provided they have minimal throughput capacity. The intersection of Cheltenham and Kenmore increases overall evacuation time by 5:00, while restricting the throughput of Cheltenham and Exeter increases evacuation time by 7:00. Restricting the throughput of Glen Albyn and Foothill increases evacuation time by 9:50, because this

intersection is a direct input to one of our two sink nodes. Restricting the throughput of Montrose and Williams increases evacuation times by 9:10.

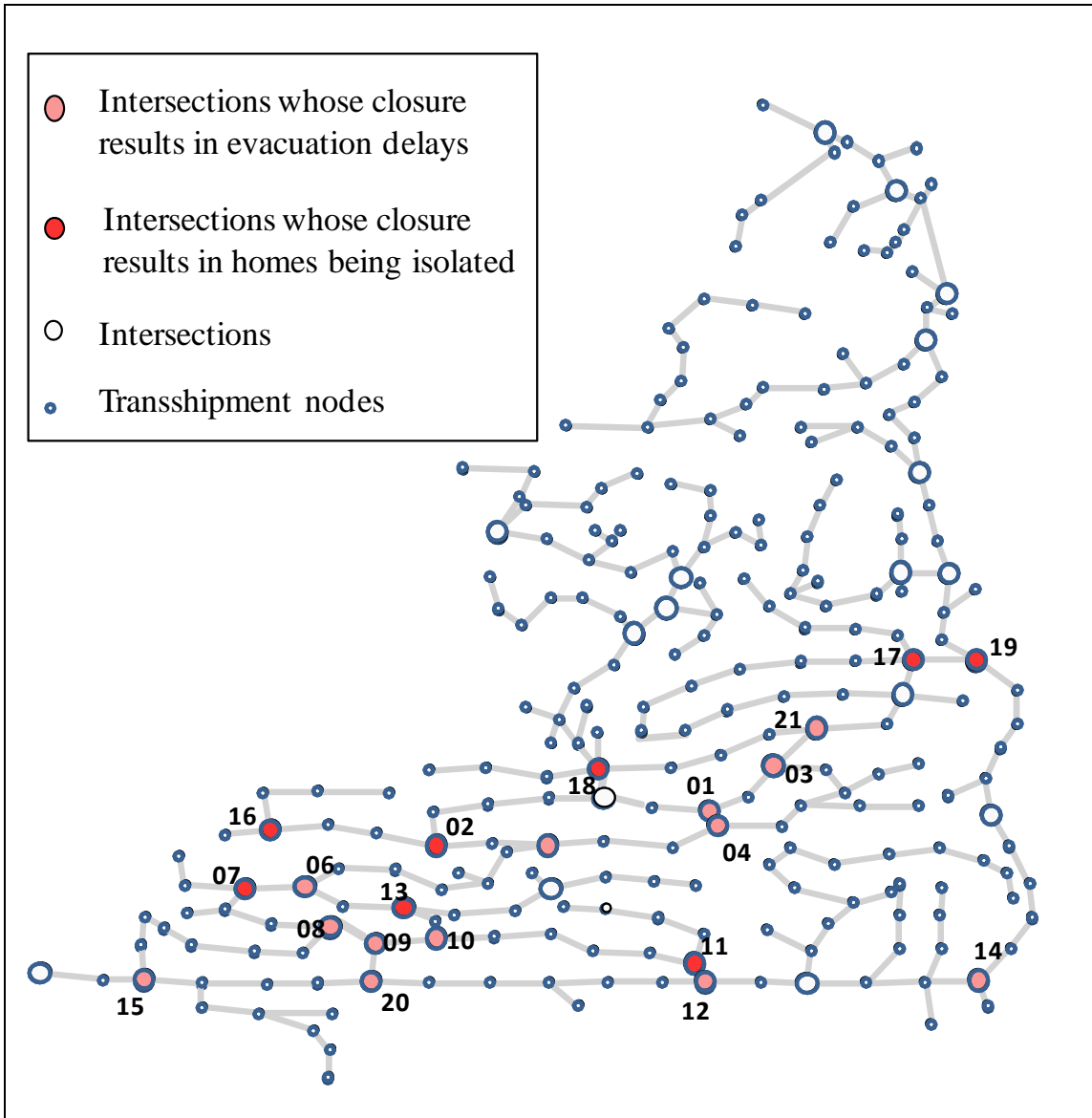

Figure 13. A network representation of Mission Canyon with critical intersections shaded in light grey. Those intersections whose closures result in the isolation of houses from the evacuation network are shaded in dark grey. The numbers correspond to the intersections listed in Table 6.

Restricting the throughput of Tunnel road at either the Tunnel and Montrose intersection or the Tunnel and Foothill intersection has the largest impact of any of the 21 intersections. For the intersection of Montrose and Tunnel, restricting capacity increases the evacuation time by 21:40, while doing so at Tunnel and Foothill increases evacuation time by 22:10. We believe these results further justify the need to ensure this portion of Tunnel Road is either fortified against disruptions or has traffic control enacted during an evacuation event. We present full results for the closure or restriction of critical intersections in Table 6.

THIS PAGE INTENTIONALLY LEFT BLANK

V. CONCLUSION

A. SUMMARY

We develop two network flow models to quantify the clearing times of neighborhood evacuations. Our first model is a spatial model that finds minimum-cost evacuation routes. We represent the Mission Canyon neighborhood as a network consisting of supply (e.g., homes), transshipment nodes (e.g., intersections), and connecting arcs (e.g., road segments), all of which are connect to a “super-sink” egress point. From this spatial model, we create a space-time model by replicating the spatial network for each of T time periods, and we solve for best-case evacuation flows in space and time.

We first develop a baseline evacuation scenario of Mission Canyon and compare it to the previous analysis of Church and Sexton (2002). We find that our model produces similar evacuation clearance time estimates as those obtained by the more time-intensive micro-simulations. With this baseline established, we exercise the model to assess the effects that various changes to our model inputs or network design have on neighborhood evacuation time. Because our model is simple and solves quickly, we are able to consider several scenarios.

We find that staggering departure times does not result in an appreciably longer clearing time than an evacuation with simultaneous departures. We conclude that the presence of background traffic flow on Foothill Road does not greatly impact the neighborhood evacuation, but rather that the overall evacuation time is more largely impacted by the interior roads of the neighborhood. We estimate that losing access to the lower Tunnel Road would more than double the time to evacuate the neighborhood for both a one- and two-car-per-household scenario. This crippling effect results when an intersection node at either end of this road segment is blocked, and we argue that efforts should be taken to ensure this road is fortified against possible closure due to natural or deliberate attacks.

We ran analyses on our network to determine the effects on evacuation time if any of 21 “critical intersections” are either isolated from the network or have their throughput capacity severely limited. Of the 21 intersections, we find that eight of them would isolate some number of houses from the network if we completely disconnect them. Similarly, we find that complete isolation of 13 of the 21 intersections result in longer evacuations. The least severe of these increases evacuation time by 50 seconds, while the most severe closure increases clearing time by 45 minutes.

We examine the results on neighborhood clearing time if each of these same 21 intersections have their throughput capacity limited to one vehicle per time period (360 per hour). These analyses show that 14 of the 21 intersections would have no impact on overall clearance times if restricted. For the other seven, the least severe delay was 0:10, while the most severe increased evacuation times by 22:10.

We recognize there is further work that will improve upon our model and make it more user-friendly and easier to deploy to various neighborhoods.

B. FUTURE WORK

1. Adding Additional Egress Points (Arcs or Sinks)

The micro-simulation work of Church and Sexton (2002) considers additional evacuation scenarios that we do not address here. Specifically, they consider how evacuation time changes if an alternate route out of the neighborhood becomes available. We can easily modify our model to experiment with alternate exit routes. Additionally, we can change our model to allow for an additional egress point from the neighborhood to the “super sink” and estimate evacuation times under this excursion.

2. Input of Data

In developing our model, we focus solely on the Mission Canyon neighborhood and we utilize a simplistic method of network mapping, Google Earth. This method is effective, but manually intensive and tedious. We believe that an automated interface with Google Earth or other Geographical Information Systems (GIS) could drastically

improve the total time necessary to model a neighborhood. By reducing the time to build the spatial network, our model becomes more quickly deployable in the event of an emergent evacuation.

3. Attacking the Network

By changing the capacity of arcs in model SPACETIME, we can assess the impact of any change in the road network on the evacuation times. In this thesis, we consider only a handful of scenarios. A more thorough approach would be to search over all sets of possible road or intersection closures to identify the worst-case disruptions. Specifically, we expect that the application of *attacker-defender models* (e.g., Brown et al., 2006) to these evacuation problems would reveal insights about the vulnerability of evacuation to the intentional actions of an intelligent adversary who wishes to increase the neighborhood clearing times.

By extension, we foresee the use of *defender-attacker-defender* models (Brown et al., 2006) to protect the neighborhood against long evacuation times. First, it provides insight into those areas of the network that should be fortified or somehow controlled to minimize the potential for traffic disruption due to the acts of an intelligent adversary (e.g., terrorist) or natural calamity (e.g., intersection wash out due to a mudslide).

In addition, there is potential for beneficial disruption of traffic flow for short periods of time. A specific example pertinent to our model is the upper region of the Mission Canyon neighborhood and the junction with the middle region of the neighborhood. The Montrose and Tunnel intersection (Tunnel24) is one of the most critical in our model based on its effect on clearing times, and houses isolated if we disconnect the arc. However, our model also indicates that the upper region of the neighborhood will likely clear slower than possible because of road congestion on Tunnel due to the evacuating traffic of middle Mission Canyon. Because upper Mission Canyon is bordered on three sides by chaparral, it is foreseeable that it would be the area of the neighborhood that would most quickly need to be evacuated due to a forest fire. We maintain that temporarily blocking the road that connects traffic from middle Mission Canyon to Tunnel Road would prove beneficial in the evacuation. By temporarily

blocking traffic from middle Mission Canyon, we believe we can achieve a quicker evacuation of the upper Mission Canyon neighborhood while not greatly impacting the overall evacuation time for the entire network. Developing the ability of our model to allow for such temporary disruptions will provide concrete data to support or disprove the notion that we can evacuate the most at-risk area of the neighborhood more quickly without a large impact on overall evacuation time by “shutting off” the arc for a short time.

4. Visualization of Results

We use Microsoft Excel to assist us in visualizing the flow of traffic during our evacuation of Mission Canyon. While this technique is incredibly helpful in seeing how the evacuation takes place, it is not yet in a format that can be easily adapted to show results for different neighborhoods. Without a visualization tool, the immense amount of data generated during our optimization is incredibly difficult to analyze, and certainly cannot be done quickly. Developing an output format, or a program interface that allows us to automatically translate the data into something we can visualize without requiring a large amount of up-front manipulation, will greatly improve the speed at which we can present useful information to decision makers in the event of a short- or no-notice evacuation.

5. Vehicle Tracking

Another natural next step is to develop the ability to tag and track individual vehicles throughout the evacuation optimization. Incorporating this with our improved output interface would allow us to show iteratively the routes that each individual house in a neighborhood should take during the “optimum” evacuation. With this knowledge, and applying our model to a neighborhood before an evacuation is necessary, we can provide each resident with detailed information about possible routes they should follow to ensure that they and the entire neighborhood evacuate as quickly as possible. Such information could be delivered to residents using the “reverse 911” system currently in place or via other social networking technologies (e.g., Twitter). While we cannot ensure

that individuals will comply with the routes presented, there is benefit in providing them the information so they have something they can rely on.

C. FINAL THOUGHTS

Over the last few decades, there has been a trend that people migrate toward areas that are disaster prone (e.g., coastal areas, urban wildland interface areas). This suggests that evacuations will become increasingly common as more people inhabit these areas. As such, understanding when to order an evacuation, how long to allow for an evacuation, and how to route individuals in an evacuation will be important for public safety officials, and often with short notice. We offer our space-time model for optimized network flow evacuation as one of many tools that emergency planners can use in answering these questions, and we provide the Mission Canyon neighborhood analysis as an example of the insights that can be obtained.

THIS PAGE INTENTIONALLY LEFT BLANK

LIST OF REFERENCES

- Ahuja, R. K., Magnanti, T. L., & Orlin, J. B. (1993). *Network flows; theory, algorithms, and applications*. Upper Saddle River, NJ: Prentice Hall.
- Brown, G. R., Carlyle, W. M., Salmeron, J., & Wood, K. J. (2006). Defending critical infrastructure. *Interfaces*, 36(6), 530–544.
- Chalmet, L. G., Francis, R. L., & Saunders, P. B. (1982). Network models for building evacuation. *Management Science*, 28(1), 86–105.
- Chiu, Y. C., & Zheng, H. (2007). Real-time mobilization decisions for multi-priority emergency response resources and evacuation groups: Model formulation and solution. *Transportation Research Part E-Logistics and Transportation Review*, 43(6), 710–736.
- Church, R. L., & Cova, T. J. (2000). Mapping evacuation risk on transportation networks using a spatial optimization model. *Transportation Research Part C-Emerging Technologies*, 8(1-6), 321–336.
- Church, R. L., & Sexton, R. M. (2002). *Modeling small area evacuation: Can existing transportation infrastructure impede public safety? : Vehicle Intelligence & Transportation Analysis Laboratory*, University of California, Santa Barbara.
- Cova, T. J., & Church, R. L. (1997). Modeling community evacuation vulnerability using GIS. *International Journal of Geographical Information Science*, 11(8), 763–784.
- Cova, T. J., & Johnson, J. P. (2003). A network flow model for lane-based evacuation routing. *Transportation Research Part a-Policy and Practice*, 37(7), 579–604.
- Cova, T. J., Dennison, P. E., Kim, T. H., & Moritz, M. A. (2005) Setting wildfire evacuation trigger points using fire spread modeling and GIS. *Transactions in GIS*, 9(4), 603–617.
- Daganzo, C. F. (2003). *A theory of supply chains*. Heidelberg Germany: Springer Verlag
- Daganzo, C. F. (1994). The cell transmission model: a dynamic representation of highway traffic consistent with the hydrodynamic theory. *Transportation Research Part B: Methodological*, 28(4), 269–287.
- Daganzo, C. F. (1995). The cell transmission model: Network traffic. *Transportation Research Part B: Methodological*, 29(2), 79–93.

- Fahy, R. F. (1995, September 10-15). EXIT89 – *An evacuation model for high-rise buildings –recent enhancements and example applications*. Paper presented at the International Conference for Fire Research and Engineering, Orlando, FL.
- Han, L. D., Yuan, F., Chin, S., & Hwang, H. (2006). Global optimization of emergency evacuation assignments. *Interfaces*, 36(6), 502–513.
- Jianfeng, L., & Bin, Z., (2009). Proceedings of the International Workshop on Intelligent Systems and Applications: *A large-scale open space emergency evacuation model*. Wuhan, China.
- Lahmar, M., Assavapokee, T., & Ardekani, S. A., (2006). Proceedings of the IEEE Intelligent Transportation Systems Conference: *A dynamic transportation planning support system for hurricane evacuation*. Toronto, Canada.
- Liu, Y., Lai, X., & Chang, G. L. (2006). Two-level integrated optimization system for planning of emergency evacuation. *Journal of Transportation Engineering*, 132(10), 800–807.

INITIAL DISTRIBUTION LIST

1. Defense Technical Information Center
Ft. Belvoir, Virginia
2. Dudley Knox Library
Naval Postgraduate School
Monterey, California