

## **HAZARD DIVISION 1.2 OPEN AIR TESTING - SUMMARY OF RESULTS**

W.D. Houchins,  
Naval Surface Warfare Center, Dahlgren Division

M.M. Swisdak, Jr.  
Naval Surface Warfare Center, Indian Head Division

M.J.A. Gould,  
United Kingdom Explosives Storage and Transport Committee Support Group

### **ABSTRACT**

Since 1990, there have been significant advances in our knowledge of the consequences and processes involving the accidental ignition of stacks of Hazard Division (HD) 1.2 ammunition stored in the open. This work has been jointly sponsored by the United Kingdom Explosives Storage and Transport Committee (UK ESTC) and the United States Department of Defense Explosives Safety Board (US DDESB). Twelve tests have been conducted under the auspices of this program. This paper describes this testing and summarizes the results that have been obtained. This summary includes times to reaction, types of reaction, amounts of ammunition actually reacting, fragmentation distributions, and airblast. In addition, the information obtained during this program is compared with previously reported testing and with recent testing in Norway and Germany.

### **GENERAL**

At present the quantity-distance (Q-D) requirements for open storage of HD 1.2 ammunition are different in the US, the United Kingdom (UK), and NATO. A fundamental difference in these systems is the methodology used to establish the Inhabited Building Distance (IBD). In the US, an IBD is established for each specific ordnance item (e.g., M1 105mm high explosive cartridge). It is based on the maximum fragment range observed in standard classification tests and it is independent of the quantity of rounds present<sup>1,2</sup>. The IBD for a stack containing different types of munitions is based solely on the IBD for the item(s) having the largest device-specific IBD; again, independent of the quantity of material that is present. In contrast, the UK and NATO establish HD 1.2 IBD's based on the total net explosive weight for a stack. Items are classified as either (a) those which produce small fragments of moderate range (HD 1.2\*) or (b) those which produce large fragments with considerable range (HD 1.2).

# Report Documentation Page

*Form Approved  
OMB No. 0704-0188*

Public reporting burden for the collection of information is estimated to average 1 hour per response, including the time for reviewing instructions, searching existing data sources, gathering and maintaining the data needed, and completing and reviewing the collection of information. Send comments regarding this burden estimate or any other aspect of this collection of information, including suggestions for reducing this burden, to Washington Headquarters Services, Directorate for Information Operations and Reports, 1215 Jefferson Davis Highway, Suite 1204, Arlington VA 22202-4302. Respondents should be aware that notwithstanding any other provision of law, no person shall be subject to a penalty for failing to comply with a collection of information if it does not display a currently valid OMB control number.

1. REPORT DATE <b>AUG 1996</b>	2. REPORT TYPE	3. DATES COVERED <b>00-00-1996 to 00-00-1996</b>	
4. TITLE AND SUBTITLE <b>Hazard Division 1.2 Open Air Testing - Summary of Results</b>		5a. CONTRACT NUMBER	
		5b. GRANT NUMBER	
		5c. PROGRAM ELEMENT NUMBER	
6. AUTHOR(S)		5d. PROJECT NUMBER	
		5e. TASK NUMBER	
		5f. WORK UNIT NUMBER	
7. PERFORMING ORGANIZATION NAME(S) AND ADDRESS(ES) <b>Naval Surface Warfare Center, Dahlgren Division, 17320 Dahlgren Rd, Dahlgren, VA, 22448-5100</b>		8. PERFORMING ORGANIZATION REPORT NUMBER	
9. SPONSORING/MONITORING AGENCY NAME(S) AND ADDRESS(ES)		10. SPONSOR/MONITOR'S ACRONYM(S)	
		11. SPONSOR/MONITOR'S REPORT NUMBER(S)	
12. DISTRIBUTION/AVAILABILITY STATEMENT <b>Approved for public release; distribution unlimited</b>			
13. SUPPLEMENTARY NOTES <b>See also ADM000767. Proceedings of the Twenty-Seventh DoD Explosives Safety Seminar Held in Las Vegas, NV on 22-26 August 1996.</b>			
14. ABSTRACT <b>see report</b>			
15. SUBJECT TERMS			
16. SECURITY CLASSIFICATION OF:			17. LIMITATION OF ABSTRACT <b>Same as Report (SAR)</b>
a. REPORT <b>unclassified</b>	b. ABSTRACT <b>unclassified</b>	c. THIS PAGE <b>unclassified</b>	
			18. NUMBER OF PAGES <b>22</b>
			19a. NAME OF RESPONSIBLE PERSON

Generally HD 1.2\* items are smaller than 60mm caliber. The respective IBD's for HD 1.2\* and 1.2 ammunition are defined as follows:

- (i) For HD 1.2\*,  $D1=53Q^{0.18}$  (D1 in meters, Q is Net Explosive Quantity (NEQ) in kilograms) with a minimum of 180m and maximum of 410m. If the exposed buildings are isolated and can be evacuated promptly, a fixed distance of 180m is allowed. Schools, hospitals, etc., must be at the D1 distance.
- (ii) For HD 1.2,  $D2=68Q^{0.18}$  with a minimum of 270m and maximum of 560m. Under similar circumstances to the above, a fixed distance of 270m is allowed. Schools, hospitals, etc., must be at the D2 distance.

The preceding formulae are believed to be based on the expected areal density of hazardous fragments resulting from a mishap. However, supporting archival test data and/or analyses cannot be traced.

For HD 1.1 mass detonating items, the internationally agreed definition for fragment-related IBD is the range at which fragment areal density reduces to 1 lethal fragment per 600 ft<sup>2</sup>. Consideration has been given to using this same criterion for HD 1.2 items. However, the database for predicting the distribution of fragments from HD 1.2 events is relatively limited. Therefore, in 1989 NATO AC/258 (Group of Experts on the Safety Aspects of Transportation and Storage of Military Ammunition and Explosives) determined that a series of bonfire tests should be conducted to investigate the hazards produced by HD 1.2 events. In order to support this effort, the US DDESB and the UK ESTC jointly sponsored the series of bonfire tests summarized in Table 1.

This paper summarizes the results of the test program. Interim results from the test program were presented at previous Department of Defense Explosive Safety Board (DDESB) Explosives Safety Seminars<sup>3,4</sup>. Additionally, detailed results from the first six tests using TNT-filled M1 105mm artillery cartridges have been published in two technical reports<sup>5,6</sup>.

## TEST ITEMS

The M1 105mm cartridge is a semi-fixed, high explosive artillery round. The general configuration of the assembled cartridge is illustrated in Figure 1. Several variants of the M1 cartridge have been produced with projectiles that contain either TNT or Composition B explosive. The cartridges are normally packaged in wooden boxes for transport and storage. Each box contains two cartridges that are packaged individually in fiberboard sleeves as shown in Figure 2. The cartridges are oriented such that the projectile of one cartridge is adjacent to the propelling charge of the other cartridge (i.e., nose-to-tail arrangement). The boxes are palletized on wooden pallets. A complete pallet contains 15 or 16 boxes depending on their arrangement. The boxes are secured on the pallet using steel banding. With the exception of test no. 7, all of the M1 cartridges that were used for this test series were assembled with aluminum closing plugs (nose plugs) in lieu of live fuzes. The cartridges that were used for test no. 7 were assembled with live fuzes when they were received. The fuzes were removed prior to testing in order to comply with range safety requirements and the fuze well of each projectile was left open.

TABLE 1. HD 1.2 BONFIRE TEST PROGRAM

<u>Test</u>	<u>Date</u>	<u>Test Items</u>	<u>Warhead</u>		<u>No. of Pallets</u>	<u>No. of Rounds*</u>	<u>Note</u>
			<u>Fill</u>	<u>Packaging</u>			
1	5-7-91	M1 105mm Artillery Cartridges	TNT	Standard wooden boxes	1	30	
2	6-24-91	M1 105mm Artillery Cartridges	TNT	Standard wooden boxes	1	30	
3	7-29-91	M1 105mm Artillery Cartridges	TNT	Standard wooden boxes	1	30	
4	10-29-91	M1 105mm Artillery Cartridges	TNT	Standard wooden boxes	8	240	
5	4-29-91	M1 105mm Artillery Cartridges	TNT	Standard wooden boxes	8	240	
6	10-28-92	M1 105mm Artillery Cartridges	TNT	Standard wooden boxes	27	864	
7	5-3-94	M1 105mm Artillery Cartridges	Comp B	Standard wooden boxes	3	96	Nose plugs omitted
8	9-15-94	M374A2 81mm Mortar Cartridges	Comp B	Standard wooden boxes	2	180	
9	5-11-95	M374A2 81mm Mortar Cartridges	Comp B	Metal boxes/plastic sleeves	2	180	
10	5-17-95	M1 105mm Artillery Cartridges	Comp B	Standard wooden boxes	4	128	
11	9-20-95	M374A2 81mm Mortar Cartridges	Comp B	Metal boxes/plastic sleeves	-	15	Five boxes
12	9-26-95	M374A2 81mm Mortar Cartridges	Comp B	Metal boxes/plastic sleeves	8	30	

\* NOTE: Test nos. 1 through 5 were conducted using pallets that contained 30 rounds (15 boxes) each. Test nos. 6, 7, and 10 were conducted using pallets that contained 32 rounds (16 boxes) each.

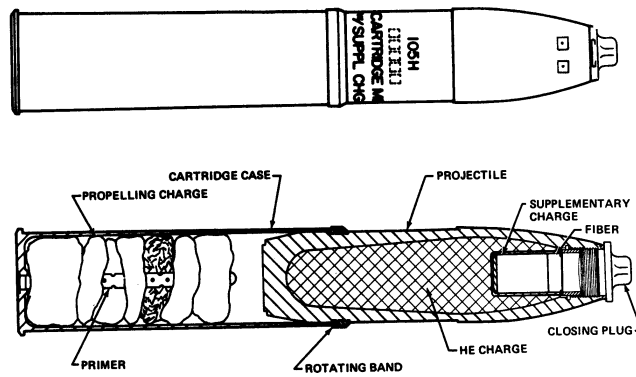

Nominal Characteristics

Projectile Body:	Forged Steel
Projectile Body Weight:	25.8 lb
Explosive Fill (HE charge):	TNT or Composition B
Explosive Weight (HE charge):	4.6 lb
Propelling Charge Case:	Spiral Wrap Steel
Propellant:	M1 Propellant
Propellant Weight:	2.8 lb
Net Explosive Weight (total)	7.4 lb

FIGURE 1. M1 105MM ARTILLERY CARTRIDGE



FIGURE 2. PACKAGING OF M1 105MM ARTILLERY CARTRIDGES

The general configuration of the M374A2 mortar cartridge is illustrated in Figure 3. The cartridges are normally packaged in wooden boxes in a manner similar to that for the M1 105mm cartridge, except that each box contains three cartridges. A complete pallet consists of 30 boxes. For test nos. 9, 11 and 12, the cartridges were repackaged in plastic tubes and steel boxes to simulate a packaging configuration that is used in the UK. Aluminum nose plugs were used in lieu of live fuzes for each of the tests of 81mm cartridges.

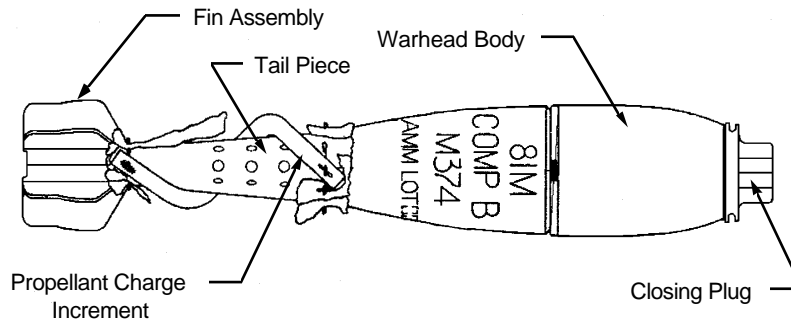

Nominal Characteristics

Warhead Body:	Forged Steel
Warhead Body Weight:	5.05 lb
Explosive Fill (HE charge):	Composition B
Explosive Weight (HE charge):	2.1 lb
Tail Piece/Fin Assembly:	Aluminum Alloy
Propellant:	M1 Propellant
Propellant Weight:	0.3 lb

FIGURE 3. M374A2 81MM MORTAR CARTRIDGE

**TEST METHOD**

Test Configurations

Test nos. 1 through 4 were conducted generally in accordance with the methodology prescribed by the UN Recommendations on the Transport of Dangerous Goods<sup>7</sup>. The test items were stacked on a steel test stand that provided approximately 30 inches clearance between the bottom of the stack and ground level. The top of the test stand was constructed as shown in Figure 4 to function as a grate. Dried lumber placed beneath the test stand and around the pallet(s) was used as kindling to provide fuel during the initial stages of the test. Four shallow steel troughs containing a small amount of gasoline (less than 5 gallons each) were placed around the base of the stack to provide an ignition source for the fire. The gasoline in the troughs was ignited using an electric squib. In order to eliminate ground cratering and burrowing of unexploded test items at the stack site (ground zero), the stack was constructed over a concrete pad. The top of the concrete pad was protected by a steel plate. A typical completed test setup is

shown in Figure 5.



FIGURE 4. CONSTRUCTION OF TEST STANDS



FIGURE 5. COMPLETED SETUP FOR TEST NO. 1

The remaining tests were conducted in the same manner except that kindling was only placed directly beneath the test stand as shown in Figure 6. This was done to more realistically simulate an accident scenario in which the test item packaging materials and the energetic components are the primary fuel source for a fire. The use of the steel plate to protect the concrete pad was discontinued after test no. 5.



FIGURE 6. COMPLETED SETUP FOR TEST NO. 4

The tests were conducted on a flat, dried lake bed. The area surrounding ground zero was scraped clear of virtually all vegetation to a range of approximately 1300 ft. The vegetation beyond the 1300-ft range consisted of clusters of desert grasses and scrubbrush. In order to facilitate recovery of the test item debris, the cleared region was marked with a 10° x 200 ft grid. Recovery of the test item debris was accomplished manually through systematic visual searches of the area by test personnel. The debris that were recovered inside the 200 ft range were not retained for analyses due to their large numbers. However, these debris were segregated according to type (i.e., warhead case piece, cartridge case piece, or miscellaneous) and the total weight of all warhead body pieces was determined. The posttest searches were limited to a range of 2000 ft or less. On-site observations and review of the video records indicated that few, if any, fragments impacted at ranges greater than 2000 ft. Thus recovery beyond this range was not considered cost effective. Additionally, the likelihood of finding any fragments that might lie in this region was considered low due to the presence of vegetation.

### Instrumentation

The test events were recorded using closed circuit video systems. Typically, one to three video cameras were positioned approximately 500 ft from the test stack to record the events that occurred within the immediate confines of the fire. Additional video cameras were positioned on hillsides overlooking the test area to record the general location of larger debris as it impacted the ground.

Blast overpressures were measured during test nos. 2 through 12 using pencil-type piezoelectric pressure transducers. The transducers were located along two or three radials at nominal ranges of 50-ft, 70-ft, 100-ft, and 200-ft. The elevation of each pressure transducer was nominally 24-in above ground level. Commencing with test no. 6, a photodetector was used to record the time at which the larger explosions occurred. This data coupled with the arrival times for the blast data permitted the approximate location of many of the larger reactions to be

estimated. Also commencing with test no. 6, type K thermocouples were used to measure temperatures at selected points within each stack. Detailed descriptions of the instrumentation systems are provided in one of the interim technical reports<sup>5</sup>.

## **OBSERVATIONS AND RESULTS**

General observations for each test are summarized in Table 2. Most of the tests produced similar results with respect to fire buildup, onset of test item reactions, levels of test item reactions, and event duration. In most of the tests the fire developed rapidly following ignition with the entire stack being engulfed within approximately five minutes. Usually the first indications of test item reactions were observed within 10 to 15 minutes after complete engulfment of the stack. These initial reactions were heard as small pops and/or seen as regions of intense burning within the stack. Most are thought to have been mild deflagrations of propellant charges and/or burning of the explosive fill in some warheads resulting in failure of the nose plug followed by rapid venting of the reaction gases. Most of the debris that were ejected from the bonfire following one of these reactions appeared to have very limited range; less than 100 ft in most instances. The relatively mild initial reactions were followed some time later by a series of much more violent reactions (explosions) that occurred intermittently throughout the remainder the test, intermingled with additional mild reactions. Each explosion was characterized by abrupt instantaneous expansion of the fire, a loud audible report, low level air shock, and scattering of burning wood and other debris about the test site. Each of these much more violent reactions was presumed to be the explosion and/or detonation of one or more warheads. Typically the fire would continue to burn at full intensity only until the first few explosions had occurred. It would then begin to die out slowly due to scattering of the stack by each successive explosion. Usually the fire was reduced to broadly scattered smoldering debris in less than one hour. However, in each test, one or more explosions were observed after the fire was effectively out.

A somewhat different response was observed in test no. 9. The fire buildup and onset of initial mild reactions were similar to that observed in the other tests. However approximately 26:11 (min:sec) after the fire was lit an extremely large explosion occurred that completely destroyed the stack and effectively cleared the test pad. No other reactions were observed after that time. A total of 102 warhead bodies were recovered essentially intact after the test which suggests that 78 warheads were involved in the explosion. Analyses of the blast overpressure data indicated that the yield was equivalent to the detonation of approximately 21 warheads.

Fragment recovery data for each of the tests are summarized in Table 3. Figures 7 and 8 show the distribution of the fragments that were recovered beyond the 200-ft range for test nos. 6 and 12. These distributions are representative of those for the other tests in that the distribution of fragments with respect to azimuthal angle was relatively uniform and the fragments having the greatest range were primarily warhead pieces. Figures 9 through 11 show some typical warhead fragments that were recovered beyond the 200-ft range. Almost all of the warhead fragments that were produced by the 105mm projectiles that were loaded with TNT explosive appeared to have been produced by explosion (vice detonation) reactions. A significant number of the warhead fragments that were produced by the 81mm mortar warheads and the 105mm projectiles that were

loaded with Composition B appeared to have been produced by detonation reactions.

The maximum blast overpressures that were observed in each test are summarized in Table 4. Figures 12 through 14 show the estimated locations of the explosions in test nos. 6, 10, and 12 based on analyses of the blast time-of-arrival data. It can be seen that all of the estimated locations are within 150-ft of the stack location. This is consistent with on-site visual observations during each of the tests.

TABLE 2. GENERAL OBSERVATIONS FOR EACH TEST

Test Observed	Stack Size (No. of Cartridges)	Elapsed Time to Initial Reaction (min:sec)	Elapsed Time to First/Last Explosion (min:sec)	No. of Explosions	No. of Projectile Bodies Recovered Intact	Maximum Fragment Range
1	30	15:32	18:24 48:53	13	17	1600-1800
2	30	20:22	24:14 42:36	9	21	1600-1800
3	30	20:05	36:48 78:40	11	18*	1400-1600
4	240	18:13	20:48 61:08	66	174	1800-2000
5	240	14:15	18:37 41:13	65	174	3140**
6	864	21:11	25:54 73:39	324#	546	1800-2000
7	96	23:48	31:38 51:58	8	82	1200-1400
8	180	17:03	22:42 41:42	89#	93	1000-1200
9	180	22:18	26:11	1	102	1400-1600
10	128	15:49	19:43 ~241###	39	88	1400-1600
11	15	10:46	16:27 18:43	4	8	800-1000
12	720	18:35	18:35 115:59	177	502	1200-1400

\* A 19th projectile body was recovered with only minor damage in the nose region (i.e., small fracture).

\*\* The remaining fragments that were recovered were found at a range less than 1600 ft.

# Based on pressure records. The frequency of explosions was so great at times that the number of explosions could not be determined from visual observation or video records. Some of these events may have been caused by propellant reactions.

## Observed by test personnel after all recording instrumentation was stopped.

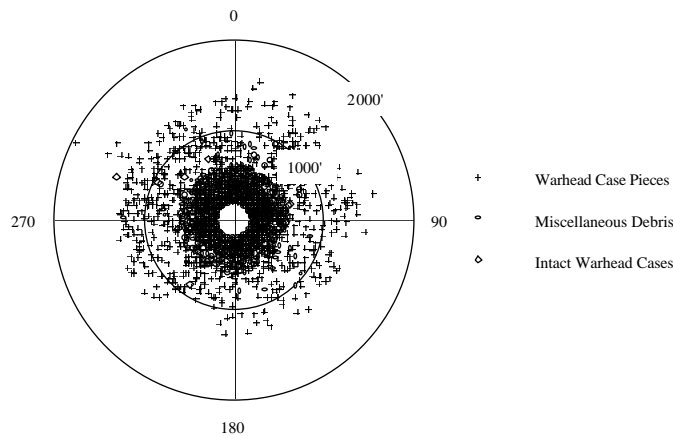

FIGURE 7. APPROXIMATE DISTRIBUTION OF FRAGMENTS AFTER TEST NO. 6

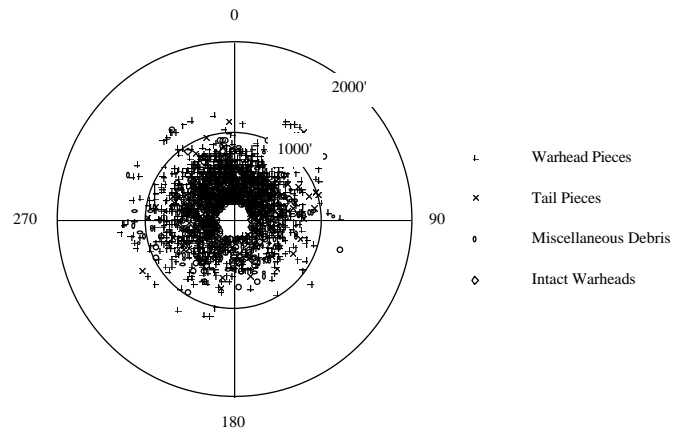

FIGURE 8. APPROXIMATE DISTRIBUTION OF FRAGMENTS AFTER TEST NO. 12

TABLE 3. FRAGMENT RECOVERY DATA

Range Interval (ft)	Test No. 1			Test No. 2			Test No. 3		
	<u>Intact Warheads</u>	<u>Warhead Pieces</u>	<u>Other Debris</u>	<u>Intact Warheads</u>	<u>Warhead Pieces</u>	<u>Other Debris</u>	<u>Intact Warheads</u>	<u>Warhead Pieces</u>	<u>Other Debris</u>
200 - 400	1	10	23	0	9	6	1	8	2
400 - 600	0	9	9	0	1	0	2	7	4
600 - 800	0	6	2	0	6	0	0	8	1
800 - 1000	0	9	0	0	1	0	0	5	0
1000 - 1200	0	7	0	0	3	0	0	5	0
1200 - 1300	0	1	0	0	3	0	0	4	0
1300 - 1400	0	0	0	0	3	0	0	2	0
1400 - 1600	0	0	0	0	4	0	0	3	0
1600 - 1800	0	2	0	0	1	0	0	0	0
1800 - 2000	0	0	0	0	0	0	0	0	0

Range Interval (ft)	Test No. 4			Test No. 5			Test No. 6		
	<u>Intact Warheads</u>	<u>Warhead Pieces</u>	<u>Other Debris</u>	<u>Intact Warheads</u>	<u>Warhead Pieces</u>	<u>Other Debris</u>	<u>Intact Warheads</u>	<u>Warhead Pieces</u>	<u>Other Debris</u>
200 - 400	6	70	471	6	41	283	37	386	2125
400 - 600	3	56	64	1	27	38	9	320	501
600 - 800	0	44	7	0	23	7	4	191	28
800 - 1000	0	27	2	1	30	2	2	212	11
1000 - 1200	1	35	1	0	32	0	0	167	3
1200 - 1300	0	21	0	0	15	0	0	82	1
1300 - 1400	0	3	0	0	1	0	1 *	23 *	0 *
1400 - 1600	0	6	0	0	2	0	0 *	13 *	0 *
1600 - 1800	0	1	0	0	0	0	0 *	0 *	0 *
1800 - 2000	0	1	0	0	0 **	0	0 *	1 *	0 *

Range Interval (ft)	Test No. 7			Test No. 8			Test No. 9		
	<u>Intact Warheads</u>	<u>Warhead Pieces</u>	<u>Other Debris</u>	<u>Intact Warheads</u>	<u>Warhead Pieces</u>	<u>Other Debris</u>	<u>Intact Warheads</u>	<u>Warhead Pieces</u>	<u>Other Debris</u>
200 - 400	0	51	116	0	96	47	31	222	1615
400 - 600	0	39	19	1	120	27	18	186	846
600 - 800	2	29	4	1	79	6	15	110	189
800 - 1000	0	7	3	0	25	1	15	43	43
1000 - 1200	0	7	1	0	5	1	9	12	16
1200 - 1300	0	7	0	0	0	0	4	9	4
1300 - 1400	0 *	2 *	0 *	0	0	0	1 *	1 *	3 *
1400 - 1600	0 *	0 *	0 *	-	-	-	1 *	2 *	4 *
1600 - 1800	0 *	0 *	0 *	-	-	-	0 *	0 *	0 *
1800 - 2000	0 *	0 *	0 *	-	-	-	0 *	0 *	0 *

Range Interval (ft)	Test No. 10			Test No. 11			Test No. 12		
	Intact Warheads	Warhead Pieces	Other Debris	Intact Warheads	Warhead Pieces	Other Debris	Intact Warheads	Warhead Pieces	Other Debris
200 - 400	0	161	170	0	8	63	16	388	1212
400 - 600	2	151	62	0	21	11	7	477	396
600 - 800	1	116	12	0	11	8	1	307	148
800 - 1000	0	70	3	1	2	0	1	101	54
1000 - 1200	0	41	0	0	0	0	0	36	12
1200 - 1300	0	11	0	0	0	0	0	20	9
1300 - 1400	0 *	4 *	0 *	-	-	-	0	0	0
1400 - 1600	0 *	2 *	0 *	-	-	-	0	0	0
1600 - 1800	0 *	0 *	0 *	-	-	-	0	0	0
1800 - 2000	0 *	0 *	0 *	-	-	-	0	0	0

\* Due to the presence of vegetation beyond the 1300-ft range, recovery was accomplished by thoroughly searching only selected azimuthal sectors. The total azimuthal region searched in tests nos. 6, 7, 9, and 10 were 150°, 90°, 180° and 220°, respectively.

\*\* One warhead case fragment was recovered at a range of 3140-ft.

# (-) indicates area was not searched.



FIGURE 9. WARHEAD FRAGMENTS PRODUCED BY 105MM PROJECTILES LOADED WITH TNT



FIGURE 10. WARHEAD FRAGMENTS PRODUCED BY 105MM PROJECTILES LOADED WITH COMPOSITION B



FIGURE 11. WARHEAD FRAGMENTS PRODUCED BY 81MM MORTAR WARHEADS

TABLE 4. MAXIMUM INDICATED PEAK OVERPRESSURES

<u>Test</u>	Maximum Indicated Overpressure (psig)			
	<u>50-ft</u>	<u>70-ft</u>	<u>100-ft</u>	<u>200-ft</u>
1	no data	no data	no data	no data
2	no data	1.25	0.66	0.26
3	3.18	1.67	0.86	0.37
4	2.80	1.42	1.08	0.49
5	3.91	1.97	0.62	0.44
6	4.00	3.14	1.35	0.90
7	3.30	1.76	1.31	0.43
8	3.10	1.52	0.81	0.35
9	7.11	3.75	3.19	0.86
10	3.64	1.97	1.38	0.38
11	1.42	0.89	0.67	0.14
12	2.44	3.20	1.09	0.38

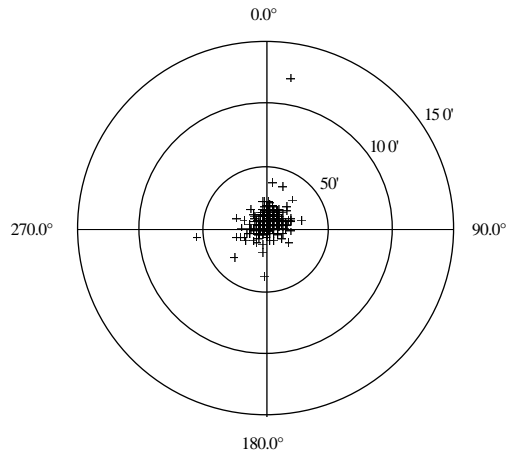

FIGURE 12. APPROXIMATE LOCATIONS OF EXPLOSIONS IN TEST NO. 6

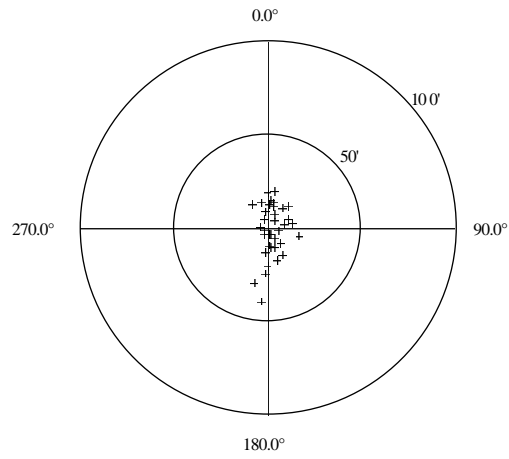

FIGURE 13. APPROXIMATE LOCATIONS OF EXPLOSIONS IN TEST NO. 10

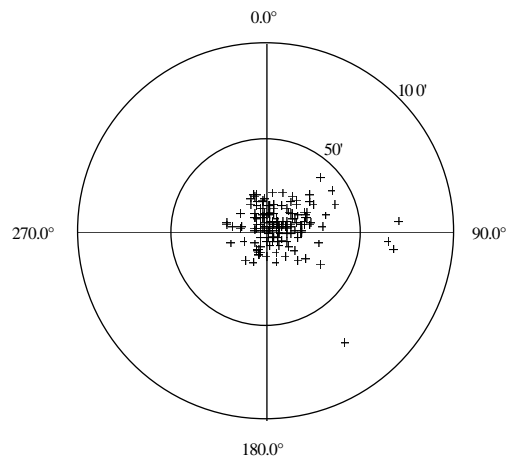

FIGURE 14. APPROXIMATE LOCATIONS OF EXPLOSIONS IN TEST NO. 12

## ANALYSES

It appears that the primary hazard associated with these HD 1.2 events is debris. Except for a small region in the immediate vicinity of the fire, air shock and firebrands do not appear to be a major hazard. As indicated previously, consideration has been given to using the same fragment areal density criterion for HD 1.1 IBD's (i.e., 1 hazardous fragment per 600 ft<sup>2</sup>) to establish IBD's for stacks of HD 1.2 items. Therefore, the objective of the following analyses is to predict the range at which the HD 1.1 fragment areal density criterion would be exceeded for larger stacks of M1 105mm artillery cartridges and M374A2 81mm mortar cartridges. In general, this has been accomplished by extrapolation of the fragment recovery data from the test program based on the following observations and assumptions:

- a. The fragment recovery data for these tests have not been subjected to rigorous statistical analyses. However, it appears that the distribution of far-field fragments with respect to azimuthal angle about the stack is fairly random as indicated in Figures 7 and 8. Therefore, it is assumed that the azimuthal distribution of fragments is uniform (i.e., there are no directional effects) and thus fragment areal densities may be assessed as a function of range only.
- b. Since there are no means to determine the trajectory of a fragment (and thus its kinetic energy) based on its range, all of the fragments that were recovered were assumed to be hazardous (i.e., >58 ft-lb kinetic energy). This includes numerous small (<0.01 lb<sub>m</sub>) warhead pieces and miscellaneous debris that were recovered within the 200 ft to 400 ft range.
- c. Generally the fragments having the greatest ranges are warhead case pieces. This suggests that warhead explosions and detonations are the primary contributor to far-field fragment hazards. Thus, far-field fragment areal densities are expected to be dependent primarily on the number of warheads that fragment rather than the total number of rounds in the stack (i.e., stack size). However, the number of warheads that fragment does generally increase with stack size.
- d. The percentage of warheads that fragment is somewhat variable. However the highest percentage observed in this test series was approximately 48% (test no 8).
- e. Based on analyses of the masses of fragments that were recovered after each test, the fragment recoveries were somewhat incomplete for all tests except test no. 6. This is particularly true for the tests of the 81mm mortar cartridges. Calculation of the approximate percentage of warhead pieces that were recovered in each test is outlined in Table 5.

TABLE 5. ESTIMATED PERCENTAGES OF RECOVERY FOR WARHEAD CASE PIECES

	Test <u>No. 1</u>	Test <u>No. 2</u>	Test <u>No. 3</u>	Test <u>No. 4</u>	Test <u>No. 5</u>	Test <u>No. 6</u>
No. of Warhead Cases that Fragmented:	13	9	12	66	65	318
Approximate Weight of Warhead Case Pieces (lb):	335	232	310	1702	1677	8204
Mass of Warhead Case Pieces Recovered Inside 200 ft Range:	118	66	86	754	879	~5400
Approximate Total Weight of Warhead Case Pieces With Range Greater Than 200 ft (lb): (Assumes 100% recovery inside 200 ft range)	217	166	224	948	789	~2804
Total Weight of Warhead Case Pieces Recovered Beyond 200 ft Range (lb):	140	153	140	600	613	3165*
% Recovery of Warhead Case Pieces With Range Greater Than 200 ft:	64%	92%	62%	63%	78%	113%
	Test <u>No. 7</u>	Test <u>No. 8</u>	Test <u>No. 9</u>	Test <u>No. 10</u>	Test <u>No. 11</u>	Test <u>No. 12</u>
No. of Warhead Cases that Fragmented:	14	87	78	40	7	218
Approximate Weight of Warhead Case Pieces (lb):	361	439	394	1032	35	1101
Mass of Warhead Case Pieces Recovered Inside 200 ft Range:	125	12	13	407	-**	365
Approximate Total Weight of Warhead Case Pieces With Range Greater Than 200 ft (lb): (Assumes 100% recovery inside 200 ft range)	239	427	381	625	-**	736
Total Weight of Projectile Body Pieces Recovered Beyond 200 ft Range (lb):	153.5*	134	91*	408*	7	197
% Recovery of Warhead Case Pieces With Range Greater Than 200 ft:	64%	31%	24%	65%	-**	27%

\* Adjusted to correct for incomplete search beyond 1300-ft range.

\*\* The mass of the warhead pieces inside the 200-ft range was not determined. Thus the percentage of recovery cannot be estimated.

Extrapolation of the test results in order to predict the relationships between stack size and the HD 1.1 areal density criterion was accomplished using the following procedure:

- (1) The fragment recovery data for each test were adjusted to compensate for the apparent shortfalls in the far-field recovery. For each test the total mass of all far-field warhead case fragments that were generated ( $m_f$ ) and the corresponding portion of far-field fragments that were actually recovered ( $P_{rec}$ ) were estimated as:

$$m_f = (N_t - N_i)m_w - m_0 \quad \text{where: } N_t = \text{number of cartridges tested}$$
$$N_i = \text{number of warhead bodies recovered intact}$$
$$m_w = \text{mass of each warhead body}$$
$$m_0 = \text{total mass of warhead pieces recovered inside 200 ft}$$

$$P_{rec} = m_r / m_f \quad \text{where: } m_r = \text{mass of all recovered far-field warhead fragments}$$

- (2) The total number of warhead case fragments for each range interval was then scaled up as:

$$n_{scaled} = n_r / P_{rec} \quad \text{where: } n_r = \text{number of warhead case pieces recovered}$$

This adjustment was applied for warhead case pieces only. The recovery data indicate that relatively few pieces of any other debris were recovered beyond a range of 600 ft. Thus, the contribution of these other debris to far-field fragment hazards is minimal and no adjustment appears warranted. Table 6 summarizes the adjusted total fragment counts for each test.

- (3) The adjusted fragment recovery data for each test were normalized to determine the average number of fragments in each range interval that were generated by each warhead that fragmented (fragments/explosion).
- (4) The maximum envelope of fragments/explosion data for each type of munition (i.e., TNT-filled 105mm cartridges, Composition B - filled 105mm cartridges, or 81mm cartridges) were then used to predict the number of fragments expected in each range interval for larger stacks. Two cases were modeled. In one case it was assumed that 50% of the warheads in the stack would fragment. This assumption is thought to be slightly conservative based on the test results. In the other case it was assumed that all of the warheads in the stack would fragment; a worst case condition.
- (5) For each selected stack size the areal density of fragments for each range interval was calculated as the total fragment count for the range interval divided by the area of the corresponding annulus. Pseudo trajectory-normal methods were used to determine the fragment count for each range interval<sup>8</sup>. Essentially this means that the fragment count for a given range interval includes all of the fragments that fall within that range interval plus all of the fragments that pass through the range interval.

- (6) The density-range estimates for each selected stack size were then fitted using interpolatory cubic splines to determine the ranges at which the areal density of fragments equaled one fragment per 600 ft<sup>2</sup>.

Figure 15 shows the predicted ranges to exceed one fragment per 600 ft<sup>2</sup> based on extrapolation of the test results using the preceding method. The corresponding IBD's established by current Q-D requirements are shown in Figure 15 for comparison.

TABLE 6. ADJUSTED FRAGMENT COUNTS

Range Interval (ft)	Total No. of Fragments					
	Test No. 1	Test No. 2	Test No. 3	Test No. 4	Test No. 5	Test No. 6
200 - 400	39.7	15.9	15.9	589.2	343.3	2548.0
400 - 600	23.1	1.1	17.3	156.7	74.7	830.0
600 - 800	11.4	6.6	13.9	77.5	37.4	223.0
800 - 1000	14.1	1.1	8.1	45.3	42.7	225.0
1000 - 1200	11.0	3.3	8.1	58.1	42.3	170.0
1200 - 1400	1.6	6.6	9.7	38.5	21.2	140.6
1400 - 1600	0.0	4.4	4.8	9.6	2.6	31.2
1600 - 1800	3.1	1.1	0.0	1.6	0.0	0.0
1800 - 2000	0.0	0.0	0.0	1.6	0.0	2.4
Beyond 2000	0.0	0.0	0.0	0.0	1.3	0.0

Range Interval (ft)	Total No. of Fragments					
	Test No. 7	Test No. 8	Test No. 9	Test No. 10	Test No. 11*	Test No. 12
200 - 400	169.5	353.2	2571.6	419.8	-	2674.9
400 - 600	60.7	410.8	1639.5	298.3	-	2181.8
600 - 800	37.0	259.0	662.6	193.0	-	1293.8
800 - 1000	13.7	80.7	237.3	111.6	-	431.6
1000 - 1200	10.6	16.9	75.0	63.6	-	146.2
1200 - 1400	16.1	0.0	61.9	27.2	-	83.6
1400 - 1600	4.3	0.0	26.7	5.1	-	0.0
1600 - 1800	0.0	0.0	0.0	0.0	-	0.0
1800 - 2000	0.0	0.0	0.0	0.0	-	0.0
Beyond 2000	0.0	0.0	0.0	0.0	-	0.0

\* The percentage of recovery for test no. 11 could not be determined.

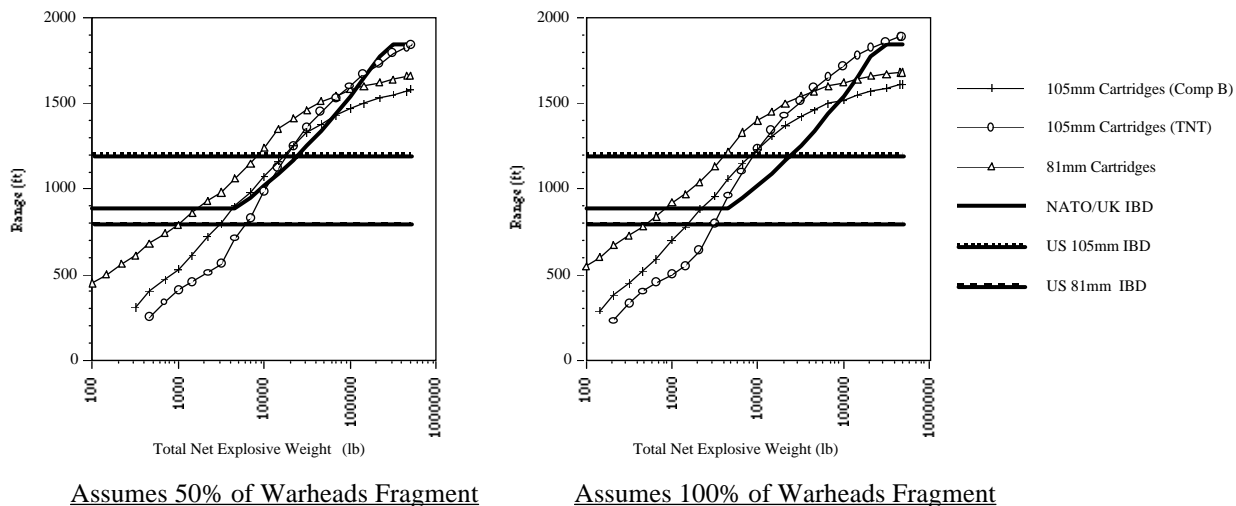

FIGURE 15. ESTIMATED RANGES TO EXCEED 1 FRAGMENT PER 600 FT<sup>2</sup> VERSUS CURRENT Q-D REQUIREMENTS

Similar analyses were performed for 40mm cartridges using data reported from two tests conducted by Norway and one test conducted recently by Germany<sup>9,10</sup>. One of the Norwegian tests was conducted using 80 MK 2 cartridges packaged in steel containers, the other using 30 MK 2 cartridges packaged in wooden boxes. The German test was conducted using one unit load (240 cartridges) of DM 31 cartridges. Additionally, unreported archival data from a US test conducted in 1980 was analyzed. This test involved 36 pallets (6912 cartridges), however the type(s) of cartridge and packaging have not been determined. The fragment recovery data from the Norwegian and US tests did not permit estimation of the percentages of recovery nor could the percentage of warheads that reacted be determined. Therefore no adjustments were made to the fragment count data to compensate for incomplete recovery and the results were normalized based on the total number of rounds (vice the number of warheads that fragmented). The results of these analyses are presented graphically in Figure 16.

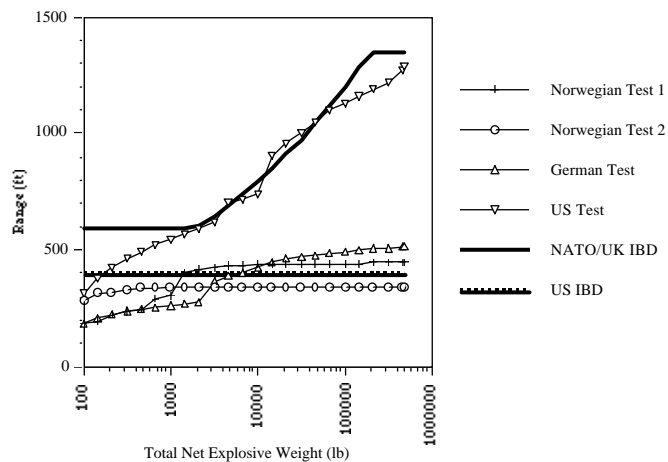

FIGURE 16. ESTIMATED RANGES TO EXCEED 1 FRAGMENT PER 600 FT<sup>2</sup> FOR 40MM ARTILLERY CARTRIDGES BASED ON BONFIRE TESTS

## CONCLUSIONS

A fire in an open stack of 105mm cartridges or 81mm cartridges typically results in a series of explosions. The first reactions are relatively nonviolent deflagration reactions and are typically observed approximately 10 to 15 minutes after the stack is completely engulfed in flame. Considerably more violent reactions begin to occur a short time later. The overall duration of the event may range from less than one hour to several hours with the last few explosions occurring after the fire is effectively out.

The most violent reactions are explosions or detonations involving one or more warheads. These reactions often produce relatively large, high velocity fragments that may have ranges approaching and possibly exceeding 2000 ft. However not all of the warheads react violently. Some of the warheads burn in a manner that does not fragment the case while others are thrown clear of the fire and do not react. During this test series, the highest percentage of warheads that reacted in a manner that caused fragmentation of the case was approximately 48%.

Fragments are dispersed randomly in azimuthal angle and the fragment density decreases rapidly with range from ground zero. Warhead body fragments are the primary contributor to far-field fragment hazards. Most of the fragments produced by the propellant charges and packaging are limited to a range of roughly 600 ft or less.

Although intact (i.e., live) warheads have been recovered several hundred feet from the ground zero, there have been very few occasions in which a warhead was thrown more than 50 ft from the burning stack and then exploded. There have been no instances in which a warhead was thrown more than 150 ft from the fire and then exploded. Thus it appears that that post-impact explosion of lobbed rounds does not contribute appreciably to overall fragment ranges.

There is an initial period of roughly 10 to 20 minutes before any reaction occurs. However, the time to first reaction may vary with many factors such as wind, the amount of fuel available, packaging materials, type/caliber of rounds, and the thermal sensitivity of the explosives. Thus, time for emergency response measures and evacuation of the area may be limited to less than 10 minutes. Accordingly, automatic fire detection and alarm systems are important features for maximizing the time available for safe evacuation. Additionally, the use of automatic drench systems may be the only safe means of fire fighting. Automatic drench systems may also mitigate (or eliminate) the fragment hazard if the fire can be extinguished early in the event.

## DISCUSSION

The preceding analyses are based on a relatively limited number of tests. Additionally, the results of the analyses include extrapolations to stack sizes that are several orders of magnitude larger than the sizes tested. Thus consideration should be given to the limitations and uncertainties that are inherent in the test data and analysis method when interpreting the analyses

results; particularly the predicted behavior for very large stacks. However, based on the results summarized in Figures 15 and 16:

a. Both the US and NATO/UK HD 1.2 IBD requirements for 81mm cartridges and 105mm cartridges appear to be conservative for relatively small stacks. The NATO/UK IBD requirements appear to be reasonable for larger stack sizes if it is assumed that no more than 50% of the warheads will fragment. However, the NATO/UK requirements may be optimistic for larger stack sizes if a greater portion of the warheads fragment. The US requirements appear to be optimistic for large stacks.

b. The results of the 40mm tests appear to be inconsistent. The maximum fragment ranges reported from the Norwegian and German test were less than 500 ft; however, the data from the US test indicates several fragments in the 1200-1400 ft range and one fragment in the 1400-1600 ft range. The NATO/UK HD 1.2 IBD requirements for 40mm cartridges appear to be very conservative based on the results of the Norwegian and German tests, however they appear reasonable based on the US test. In contrast, the US IBD for 40mm cartridges appears to be very optimistic based on the US test and slightly optimistic based on the Norwegian and German tests.

c. The predicted  $1/600$  ranges become asymptotic with range for very large stacks. This is consistent with the intuitive expectation that there is some maximum fragment range within which all fragments must be contained, regardless of the number of fragments generated.

## REFERENCES

1. DoD 6055.9-STD, Department of Defense Ammunition and Explosives Safety Standards, October 1992.
2. Department of Defense Explosives Hazard Classification Procedures, NAVSEAINST 8020.8A (Army TB 700-2, Air Force TO 11A-1-47 Defense Logistics Agency DLAR 8220.1), December 1989.
3. Gould, M.J.A. and Houchins, W.D., "Trials to Determine the Consequences of the Accidental Ignition of Stacks of Hazard Division 1.2 Ammunition", Minutes of the Twenty-Fifth DOD Explosives Safety Seminar, August 1992.
4. Gould, M.J.A. and Houchins, W.D., "Trials to Determine the Consequences of the Accidental Ignition of Stacks of Hazard Division 1.2 Ammunition", Minutes of the Twenty-Fifth DOD Explosives Safety Seminar, August 1994.
5. Swisdak, M.M., Jr. and Rye, K.W., Hazard Division 1.2 Tests - Instrumentation Results and Interpretation, NSWCDD/TR-93/218, NSWCDD, Dahlgren, VA, 9 March 1994.
6. Houchins, W.D., Hazard Division 1.2 Ammunition Bonfire Tests, NSWCDD/TR-93/631, NSWCDD, Dahlgren, VA, July 1995.
7. United Nations Recommendations on the Transport of Dangerous Goods, Tests and Criteria, ST/SG/AC.10/11 Current Revision.
8. Swisdak, M.M., Jr., "Procedures for the Analysis of the Debris Produced by Explosion Events", Minutes of the Twenty-Fourth Explosives Safety Seminar, August 1990.
9. Information on the Fire of 14<sup>th</sup> May 1985 in Norway in a Semi-Trailer Loaded with 40mm HE-T Ammunition - Report from External Stack Fire Test, NATO AC/258-NO (MG) IWP 80, 24 April 1986.
10. German Federal Armed Forces Material Office ltr MatABw-IV-AC/258 GE(ST)IWP 1-96 of 19 January 1996; Subj: HD 1.2 40mm Trials - Results of Pilot Test