



AFRL-RZ-WP-TP-2010-2084

**CRITICAL CURRENT IN YBCO COATED CONDUCTORS
IN THE PRESENCE OF A MACROSCOPIC DEFECT
(POSTPRINT)**

**Milan Polak and Pavol Mozola
Slovak Academy of Sciences**

**Paul N. Barnes and George A. Levin
Mechanical Energy Conversion Branch
Energy/Power/Thermal Division**

MARCH 2010

Approved for public release; distribution unlimited.

See additional restrictions described on inside pages

STINFO COPY

© 2009 IEEE

**AIR FORCE RESEARCH LABORATORY
PROPULSION DIRECTORATE
WRIGHT-PATTERSON AIR FORCE BASE, OH 45433-7251
AIR FORCE MATERIEL COMMAND
UNITED STATES AIR FORCE**

REPORT DOCUMENTATION PAGE

Form Approved
OMB No. 0704-0188

The public reporting burden for this collection of information is estimated to average 1 hour per response, including the time for reviewing instructions, searching existing data sources, gathering and maintaining the data needed, and completing and reviewing the collection of information. Send comments regarding this burden estimate or any other aspect of this collection of information, including suggestions for reducing this burden, to Department of Defense, Washington Headquarters Services, Directorate for Information Operations and Reports (0704-0188), 1215 Jefferson Davis Highway, Suite 1204, Arlington, VA 22202-4302. Respondents should be aware that notwithstanding any other provision of law, no person shall be subject to any penalty for failing to comply with a collection of information if it does not display a currently valid OMB control number. **PLEASE DO NOT RETURN YOUR FORM TO THE ABOVE ADDRESS.**

1. REPORT DATE (DD-MM-YY) March 2010	2. REPORT TYPE Journal Article Postprint	3. DATES COVERED (From - To) 01 July 2007 – 01 July 2009
--	--	--

4. TITLE AND SUBTITLE CRITICAL CURRENT IN YBCO COATED CONDUCTORS IN THE PRESENCE OF A MACROSCOPIC DEFECT (POSTPRINT)	5a. CONTRACT NUMBER In-house
	5b. GRANT NUMBER
	5c. PROGRAM ELEMENT NUMBER 62203F

6. AUTHOR(S) Milan Polak and Pavol Mozola (Slovak Academy of Sciences) Paul N. Barnes and George A. Levin (AFRL/RZPG)	5d. PROJECT NUMBER 3145
	5e. TASK NUMBER 32
	5f. WORK UNIT NUMBER 314532ZE

7. PERFORMING ORGANIZATION NAME(S) AND ADDRESS(ES) Slovak Academy of Sciences Institute of Electrical Engineering SK-84104 Bratislava, Slovakia	Mechanical Energy Conversion Branch (AFRL/RZPG) Energy/Power/Thermal Division Air Force Research Laboratory, Propulsion Directorate Wright-Patterson Air Force Base, OH 45433-7251 Air Force Materiel Command, United States Air Force
---	--

8. PERFORMING ORGANIZATION REPORT NUMBER AFRL-RZ-WP-TP-2010-2084
--

9. SPONSORING/MONITORING AGENCY NAME(S) AND ADDRESS(ES) Air Force Research Laboratory Propulsion Directorate Wright-Patterson Air Force Base, OH 45433-7251 Air Force Materiel Command United States Air Force	10. SPONSORING/MONITORING AGENCY ACRONYM(S) AFRL/RZPG
--	---

11. SPONSORING/MONITORING AGENCY REPORT NUMBER(S) AFRL-RZ-WP-TP-2010-2084

12. DISTRIBUTION/AVAILABILITY STATEMENT Approved for public release; distribution unlimited.
--

13. SUPPLEMENTARY NOTES Journal article published in the <i>IEEE Transactions on Applied Superconductivity</i> , Vol. 19, No. 3, June 2009. PA Case Number: 88ABW-2009-2981; Clearance Date: 01 Jul 2009. Paper contains color. © 2009 IEEE. The U.S. Government is joint author of the work and has the right to use, modify, reproduce, release, perform, display, or disclose the work.
--

14. ABSTRACT We have studied the effects of localized defects in the YBCO coated conductors on the critical current. The artificial defects were introduced into 4, 10 and 12 mm wide tapes as cuts of various lengths made either by laser ablation or mechanical means. Transport measurements were carried out in an external variable magnetic field to obtain the I-V characteristics of the damaged areas. The distribution of the magnetic field in the vicinity of the defects has been mapped as well. The reduction of the critical current by the defects, with and without an external DC magnetic field are discussed and compared with existing theories. A criterion for determining the critical current in the area containing a defect is suggested.
--

15. SUBJECT TERMS superconductivity, flux pinning, critical current density, magnetic field, YBa ₂ Cu ₃ O _{7-z} or YBCO, localized defects, current transport theories

16. SECURITY CLASSIFICATION OF:			17. LIMITATION OF ABSTRACT: SAR	18. NUMBER OF PAGES 10	19a. NAME OF RESPONSIBLE PERSON (Monitor) Timothy J. Haugan 19b. TELEPHONE NUMBER (Include Area Code) N/A
a. REPORT Unclassified	b. ABSTRACT Unclassified	c. THIS PAGE Unclassified			

Critical Current in YBCO Coated Conductors in the Presence of a Macroscopic Defect

Milan Polak, Paul N. Barnes, Pavol Mozola, and George A. Levin

Abstract—We have studied the effects of localized defects in the YBCO coated conductors on the critical current. The artificial defects were introduced into 4, 10 and 12 mm wide tapes as cuts of various lengths made either by laser ablation or mechanical means. Transport measurements were carried out in an external variable magnetic field to obtain the I-V characteristics of the damaged areas. The distribution of the magnetic field in the vicinity of the defects has been mapped as well. The reduction of the critical current by the defects, with and without an external DC magnetic field are discussed and compared with existing theories. A criterion for determining the critical current in the area containing a defect is suggested.

Index Terms—Coated conductors, defects, HTS, YBCO.

I. INTRODUCTION

CURRENT-BLOCKING obstacles such as grain boundaries, second phase precipitates, pores, micro-cracks, etc. in $\text{YBa}_2\text{Cu}_3\text{O}_{7-x}$ (YBCO) reduce the critical current density [1] and give rise to an inhomogeneous current distribution in the vicinity of these defects. Cracks and porosity in the YBCO layer produced during the fabrication process of the high temperature superconductor (HTS) YBCO coated conductors can limit the critical current density (J_c) considerably [2]. Additional defects that can reduce J_c may be introduced during the handling of the tape, for example, due to excessive tensile stress [3] or tape bending. If the superconducting tapes exhibit a “bowing,” then additional damage can occur when the conductor is wound onto cylindrical formers to make pancake coils.

Magneto-optical imaging (MOI) and scanning laser microscopy (SLM) are frequently used to characterize HTS samples [4]–[8]. For MOI, the samples are often quite short (centimeters) and narrow (to reduce the currents). It may be difficult to investigate samples from the tapes without their modification. The sensitivity of the method is $\sim 10^{-4}$ T and limited by saturation of the indicator film. Koyanagi *et al.* [5] measured the local current flow around transverse artificial defects in YBCO deposited on SrTiO_3 . The sample

Manuscript received August 25, 2008. First published June 30, 2009; current version published July 15, 2009. This work was supported in part by the Air Force Research Laboratory and Office of Scientific Research, Grant FA8655-07-1-3005.

M. Polak and P. Mozola are with the Institute of Electrical Engineering, Slovak Academy of Sciences, SK-84104 Bratislava, Slovakia (e-mail: milan.polak@savba.sk).

P. N. Barnes and G. A. Levin are with the Air Force Research Laboratory, Wright-Patterson AFB, OH 45433, USA (e-mail: paul.barnes@wpafb.af.mil).

Color versions of one or more of the figures in this paper are available online at <http://ieeexplore.ieee.org>.

Digital Object Identifier 10.1109/TASC.2009.2019090

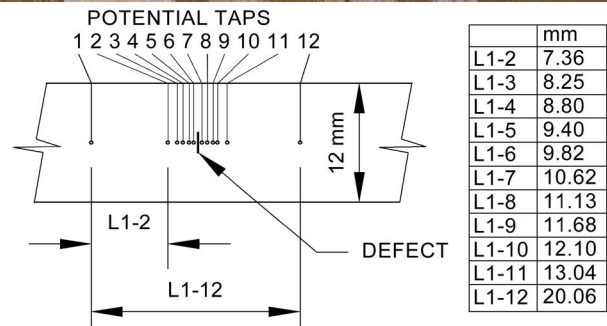

Fig. 1. Microphotograph of Sample 1 with the transverse defect 7 mm long and the 6 pairs of the potential taps (taps 1–6 on the left side, 7–12 on the right side of the defect). The table shows the distances between the taps.

carried various bias currents and the current distribution in the longitudinal direction was affected in the distance smaller than $100 \mu\text{m}$. Abramov *et al.* [6] used low temperature laser scanning microscopy and magneto-optical imaging to study the influence of transverse defects and showed the existence of flux flow channels with electric fields well above those used in the definition of the critical current (I_c).

In this work, we studied the effect on I-V curves and critical currents caused by artificial linear defects oriented perpendicular to the current flow. Using a sequence of voltage taps we also measured the distribution of the electric field in the vicinity of the defect to determine how far from the defect the field is distorted and whether the reduction of the I_c is proportional to the size of the defect. We also measured the magnetic field in the vicinity of the defects due to magnetization currents induced in the tape by ramping up and down an applied magnetic field.

II. EXPERIMENTAL

To study the influence of defects we used YBCO coated conductors manufactured by SuperPower, Inc. Sample 1 was made from a $12 \times 90 \text{ mm}^2$ tape stabilized by a $20 \mu\text{m}$ thick electroplated copper layer. Transverse defects of various lengths (1.9 mm, 3.5 mm, 5 mm and 7 mm) were successively made in the tape center using a micro-drill. Several potential taps were attached to the tape at various distances from the defect. Fig. 1 shows Sample 1 with a 7 mm long defect and the 12 potential taps. As a note, the location of potential taps changed for the

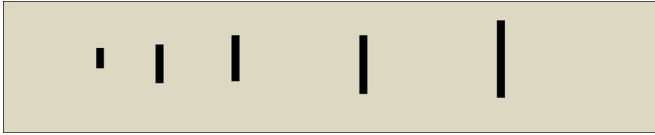

Fig. 2. A sketch of Sample 2 with the 5 artificial defects made by laser cutting. The tape width is 10 mm, the length is 65 mm.

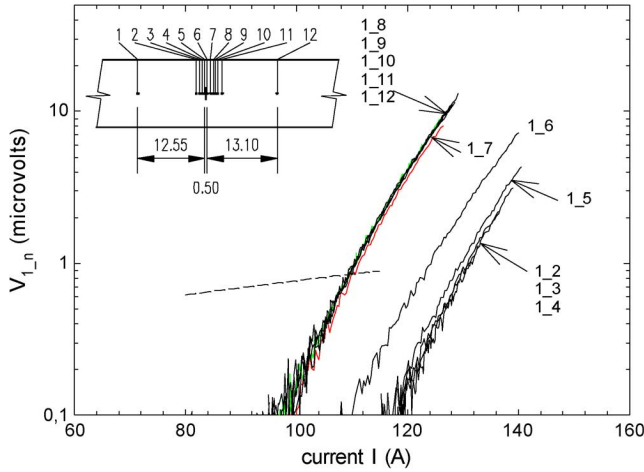

Fig. 3. I-V curves measured between the reference tap 1 and other taps (see inset) in Sample 1 with defect 3.5 mm long in external magnetic field of 74 mT. The dashed line corresponds to the relationship (5), $V = r_0 I$. The intersection point determines the critical current of the damaged section.

different lengths of the defect as the taps were reapplied several times.

Sample 2 (Fig. 2) was a $10 \times 65 \text{ mm}^2$ tape, covered by a $3 \mu\text{m}$ thick layer of Ag. Five artificial defects (cuts 1 mm, 2 mm, 3 mm, 4 mm and 5 mm long) were made using laser ablation. The width of each cut was about 0.01 mm.

Sample 3 was a 4 mm wide YBCO coated conductor covered by a $\sim 3 \mu\text{m}$ thick silver layer. A defect 1 mm long in the tape center oriented perpendicular to the tape axis was made by micro-drill. A pair of potential taps distanced by 19 mm was attached to the tape with the defect between them. Results and Discussion.

A. I-V Curves and Critical Currents

For Sample 1, we measured the I-V curves between the reference tap 1 and tap 2, 1 and 3, 1 and 4, etc., up to 1 and 12 for each of the defect lengths. As an example, in Fig. 3 we show the I-V curves measured for Sample 1 with the 3.5 mm long defect. From these measurements we obtained the profiles of the potential drop $V_{1,n}$ as a function of distance from the reference tap 1, $L_{1,n}$. In Figs. 4(a)–4(c) the profiles $V_{1,n}$ are shown for different lengths of defects and at several values of current. As depicted, the voltage rapidly changes only in close proximity to the defect. This indicates that the electric field is strongly localized around the defect. The difference in the voltages measured, for the 7 mm defect of Fig. 1, between taps 6 & 7 (0.65 mm apart) and taps 1 & 12 (20 mm apart) is very small.

As a consequence, the usual criterion for critical current I_c —the magnitude of the *average electric field* between the voltage taps—is not applicable to the situation where I_c is

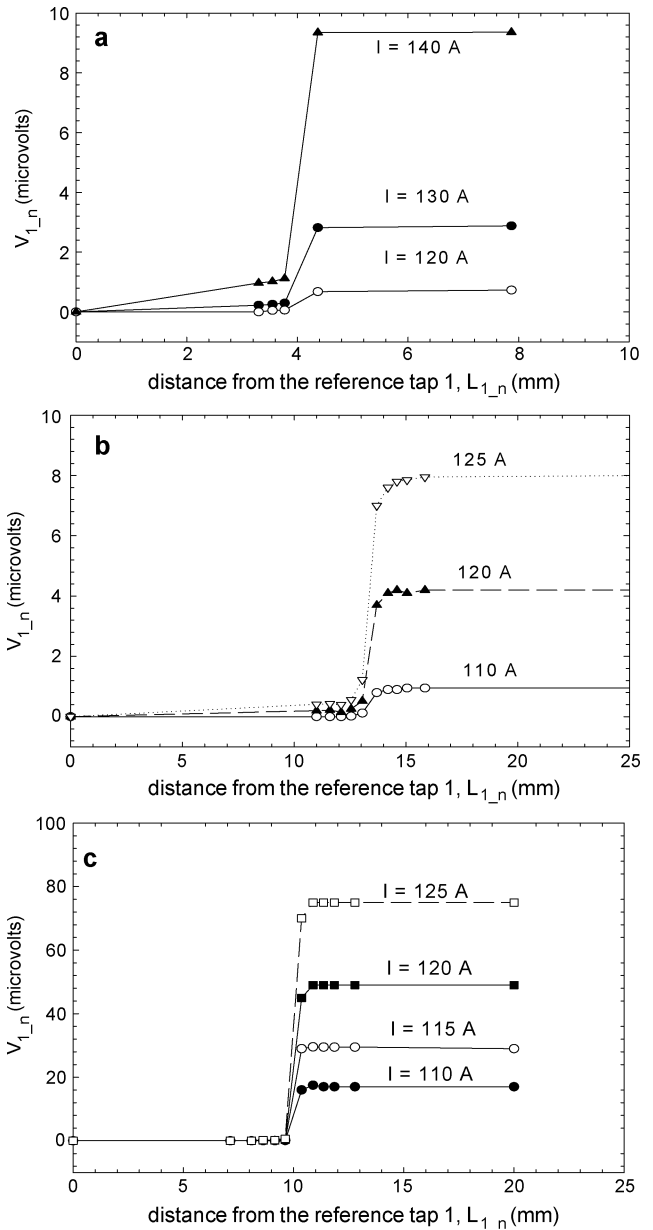

Fig. 4. The voltages measured for Sample 1 between Reference Tap 1 and other taps vs. the distance from Tap 1, $L_{1,n}$, measured at the different currents indicated in the figures where Sample 1 has a defect length of: (a) 1.9 mm long (only 6 potential taps were used in this measurement), (b) 3.5 mm long, and (c) 5 mm long.

determined by a localized defect. Another empirical criterion needs to be chosen. As the data in Figs. 4 indicate, the potential drop across the defect, or its derivations such as resistance $r(I) = V/I$, can be an objective criterion defining I_c , because it is independent of the distance between the voltage taps. The critical current I_c defined by the new criterion in the area around a defect has to be related to the critical current I_c^0 in the undamaged sections of the same conductor. The latter is determined by the commonly accepted criterion of the electric field $E_0 = 1 \mu\text{V}/\text{cm}$, according to the relationship:

$$E = E_0 \left(\frac{I}{I_c^0} \right)^n \equiv r(I)J, \quad (1)$$

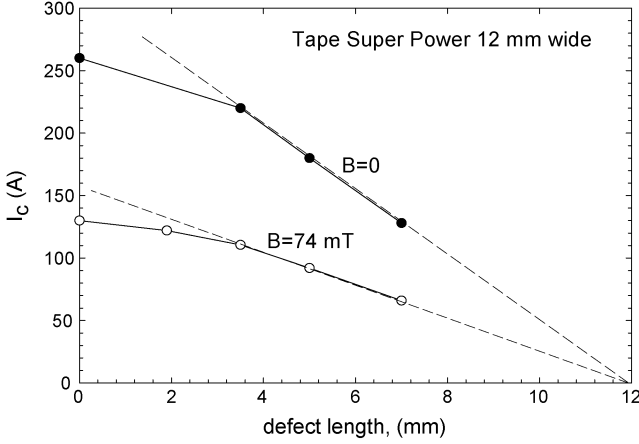

Fig. 5. Critical current I_c defined by $1 \mu\text{V}/\text{cm}$ at zero applied field and $B = 74 \text{ mT}$ as a function of the defect length.

where

$$r(I) = \frac{E_0}{J_c^0} \left(\frac{J}{J_c^0} \right)^{n-1}. \quad (2)$$

Here $J = I/W$ is the current density per unit width (A/cm), W is the tape width and J_c^0 is the critical current density per unit width in the undamaged sections.

Here we will define critical current determined by a defect in terms of the critical sheet resistance r_0 . In the undamaged section of the conductor at $J = J_c^0$ the resistance of a $W \times W$ square of the tape is equal to

$$r_0 = \frac{E}{J} \Big|_{\text{critical}} = \frac{E_0}{J_c^0}. \quad (3)$$

In the damaged section we will define the critical current by the criterion that the resistance of a $W \times W$ square that includes the defect is the same as the critical resistance of the undamaged section of the same conductor:

$$\frac{V}{I} = r_0 = \frac{E_0}{J_c^0}. \quad (4)$$

For example, let us assume that the critical current in the undamaged section of a conductor, determined by the conventional criterion (1), is 108 A/cm . This corresponds to the critical sheet resistance, (3), $r_0 = E_0/J_c^0 = 0.93 \times 10^{-8} \Omega$. In the damaged section of the same conductor we measure the potential drop across the defect, as shown in Fig. 3, and define the critical current by the condition that

$$V(I) = I \times 0.93 \times 10^{-8} \Omega. \quad (5)$$

The advantages of this definition are that the voltage across the defect does not depend on the spacing between the voltage taps and that the critical current in the damaged section can be correlated with that in the nearby undamaged section.

In Fig. 5 the degradation of the critical current in Sample 1 caused by the defects of different lengths is shown. The voltage was measured across the defects between the most separated taps (1 and 12). Without the defects, the critical current is 130 A

in a field of $B = 74 \text{ mT}$ and 260 A in self-field. This corresponds to the critical current density $J_c^0 = 108 \text{ A/cm}$ and $J_c^0 = 217 \text{ A/cm}$, respectively, with corresponding critical resistances, (3), $r_0 = 0.93 \times 10^{-8} \Omega$ and $r_0 = 0.46 \times 10^{-8} \Omega$. Preliminary results shown in Fig. 5 indicate that the critical current I_c decreases almost linearly with increasing defect length. More detailed results will be presented elsewhere.

B. Magnetization Currents in the Vicinity of Defects

Magnetization currents induced in HTS thin films are very sensitive to any weak points since the electric fields in magnetization measurements are very low. In Sample 2, magnetization currents were induced by an externally applied magnetic field that was changed from $0 \text{ T} \rightarrow 0.15 \text{ T} \rightarrow 0 \text{ T}$. The magnetic field produced by these magnetization currents were scanned in the vicinity of each defect by a micro Hall probe with a sensitivity of $\sim 100 \text{ mV/T}$. The magnetic field component perpendicular to the plane of the tape, B_{sz} , was measured across the width of the tape (x-coordinate) and at various positions along the length of the tape (y-coordinate) with y-steps of 0.2 mm . The field maps measured in the vicinity of the defects with a length of 2 mm , 3 mm and 5 mm are shown in Figs. 6(a)–6(c).

The distribution of magnetic field is affected by the presence of the defect at a distance y^* from the defect. One can estimate the characteristic distance y^* as being 1 mm , 1.75 mm and 2.5 mm for the defects 2 mm , 3 mm and 5 mm long respectively. According to [1] the nonlinearity of $E(J)$ characteristic results in a long-range disturbance of the electric field along the direction of the current flow on a scale length of $L_{\parallel} \sim a(n/\pi)^{1/2}$, where the defect length is $2a$ and n is the exponent in (1). For our case with $2a = 2 \text{ mm}$, $n = 20$ we obtain $L_{\parallel} = (20/\pi)^{1/2} = 2.5 \text{ mm}$. The predicted value about 2.5 times larger, but of the same order of magnitude that the measured value. This is also the case for longer defects where the theoretical values are also larger than those obtained by the experiment when magnetization currents are considered.

C. Transport Current in the Vicinity of a Defect

We mapped the magnetic field in the vicinity of the Sample 3 with the defect, carrying a current of 44.9 A in a magnetic field of 93 mT . This current is very close to the critical value for the sample. The 3D map of the magnetic field is shown in Fig. 7. The data show that the current flow is disturbed due to the defect over the distance of about $\pm 0.75 \text{ mm}$, which is nearly equal to the defect length. It appears that in the presence of transport current the distance over which the current flow is perturbed is greater than in the magnetization tests shown in Fig. 6 without transport current.

III. CONCLUSION

The reduction of the transport critical currents in 12 mm copper stabilized YBCO tape due to linear defects of different lengths (aligned perpendicular to the current flow) scales fairly well with the length of the defect, especially for larger defects. More work is needed to clarify this issue using a criterion of critical current described above.

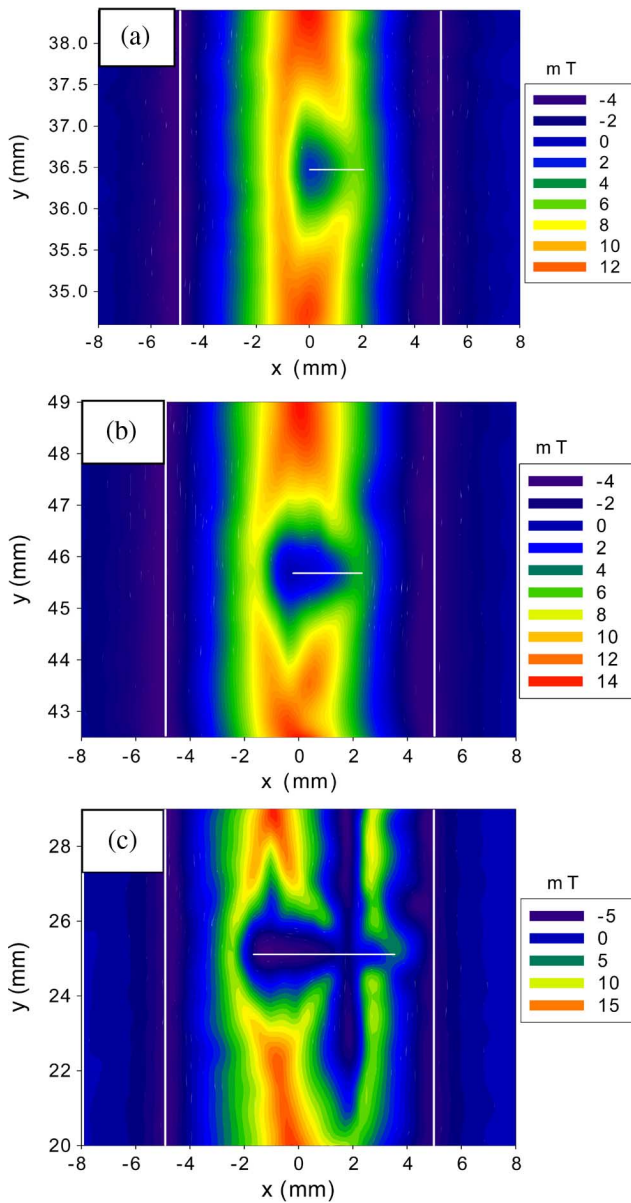

Fig. 6. The magnetic field map $B_{sz}(x,y)$ in the vicinity of defects in Sample 2 with a defect of length: (a) 2 mm, (b) 3 mm, and (c) 5 mm.

The electric field measured along the axis of the tape with a defect is strongly non-uniform. At a distance greater than 1 mm from the defect and for currents close to I_c the electric field is small and is practically unaffected by the defect. The electric field is strongly localized in the vicinity of the defect. As a result, the voltage drop across the linear defect is practically independent of the distance between the voltage taps as long as they are separated by a distance greater than 1 mm. We suggest that the voltage, rather than the average electric field, is an appropriate criterion for determining how the critical current is degraded by a defect.

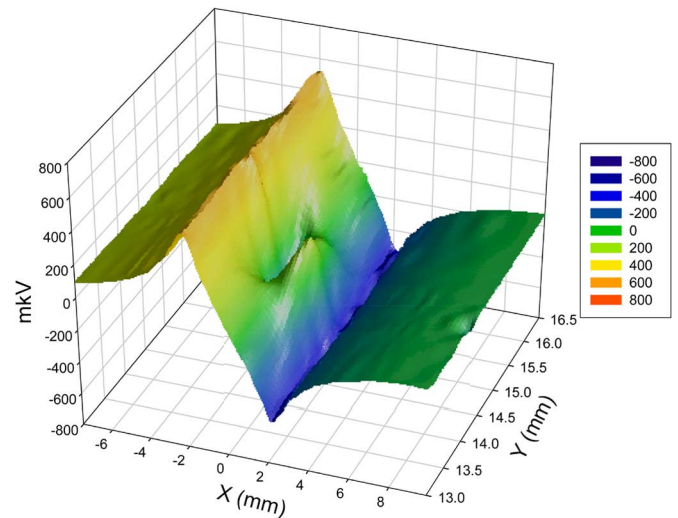

Fig. 7. 3D map of the magnetic field in the vicinity of the defect where Sample 3 carries a transport current of 44.9 A in an external magnetic field of 93 mT.

The Hall probe magnetic measurements of the magnetic field due to magnetization currents, measured above the surface of a sample containing a linear defect revealed that the distribution of the magnetization currents is distorted over a distance approximately half the length of the defect. The perturbation of the current flow by a defect is more pronounced in the presence of the transport current

REFERENCES

- [1] M. Friesen and A. Gurevich, "Nonlinear current flow in superconductors with restricted geometries," *Phys. Rev. B*, vol. 63, p. 064521, 2001.
- [2] R. Teranishi, J. Matsuda, K. Nakaoka, H. Fuji, Y. Aoki, Y. Kitoh, T. Izumi, and Y. Yamada, "High-Jc thick YBCO coated conductors by TFA-MOD process," *IEEE Trans. Applied Superconductivity*, vol. 15, no. 2, pp. 2663–2666, June 2005.
- [3] A. Antonevici, A. Villaume, C. Villard, A. Sulpice, P. B. Maron, D. Bourgault, and L. , "Porcar, coated conductors under tensile stress," *Journal of Physics: Conference Series*, vol. 43, pp. 195–198, 2006.
- [4] A. Villaume, L. Porcar, D. Bourgault, A. Antonevici, T. Caroff, J. P. Leggeri, and C. Villard, "In situ strain and transport magneto-optical investigations in superconductors," *Supercond. Sci. Technol.*, vol. 21, p. 034009, 2008.
- [5] K. Koyagani, T. Kiss, M. Inoue, T. Nakamura, K. Imamura, M. Takeo, and Y. Shiohara, "Measurement of local current flow around transverse defects in YBCO films by use of scanning SQUID microscope," *Physica C*, vol. 445–448, pp. 677–681, 2006.
- [6] D. V. Abramov, D. M. Feldmann, A. A. Polyanskii, A. Gurevich, S. Liao, G. Daniels, D. C. Larbalestier, A. P. Zhuravlev, and A. V. Ustinov, "Imaging local dissipation and magnetic field in YBCO films with artificial defects," *IEEE Trans. Appl. Supercond.*, vol. 15, pp. 2954–2957, 2005.
- [7] C. Kwon, J. L. Young, R. G. James, G. A. Levin, T. J. Haugan, and P. N. Barnes, "Effects of local artificial defects in multifilamentary coated conductors with patterned links," *J. Appl. Physics*, vol. 101, p. 083908, 2007.
- [8] T. Kiss, M. Inoue, M. Yasunaga, H. Tokutomi, Y. Iijima, K. Kakimoto, T. Saitoh, Y. Tokunaga, T. Izumi, and Y. Shiohara, "Low temperature scanning laser microscopy of YBCO coated IBAD tapes," *IEEE Trans. Appl. Supercond.*, vol. 15, pp. 3656–3659, 2005.