

FREQUENCY AND TIME SYNCHRONIZATION IN DIGITAL COMMUNICATIONS NETWORKS

M. Kihara and K. Hisadome
Nippon Telegraph and Telephone Corporation
1-2356, Take, Yokosuka-shi
Kanagawa 238-03, Japan

ABSTRACT

Frequency distribution performance will be improved with the installation of a new synchronization equipment (slave clock) in Nippon Telegraph and Telephone Corporation's (NTT's) network. In the slave clock system, the PLL has been optimally designed so that the total phase-time variation in the whole network is significantly less than 10 μ s. This phase-time variation is recommended by International Telegraph and Telephone Consultative Committee (CCITT). The design method and PLL control algorithm enable both an optimum time constant of the PLL and a frequency departure of 10^{-12} in a holdover operation.

The functions of the frequency distribution system has the intrinsic capability of being expanded and applied to a time transfer system. Since the frequencies are synchronized, a phase-time of the standard frequency signal can be synchronized to a coordinate time scale by an initial time setting, e.g., using portable clocks. Time synchronization capability is determined by the relative phase-time variation of standard frequency signals and the time accuracy of the initial phase-time setting. Relative phase-time variation can be reduced to within 500 ns by using wander correction. The initial time accuracy is within 0.1 μ s in conventional portable cesium beam standards. The time accuracy in NTT's digital networks is expected to 100 ns to 600 ns.

1. INTRODUCTION

Time and time intervals are important subjects in the digital communication network field. Digital multiplexing and time-division switching are based on precise time and time interval signals, controlled by so-called network synchronization. Network synchronization extends throughout the main nodes. Recently high-speed synchronous terminals also require reference clocks supplied by network synchronization[1].

Nippon Telegraph and Telephone Corporation (NTT) of its network will improve the frequency distribution performance with the installation of a new slave clock system. International Telegraph and Telephone Consultative Committee (CCITT) recommends requirements for reference clocks such as frequency departure with a national standard, slave clock performance and jitter and wander at node outputs[2]. This paper discusses the characteristics of the new slave clock system supposing the CCITT requirements are met.

Jitter and wander at node outputs are determined by the characteristics of the slave clock system. In master-slave synchronization, jitter and wander are accumulated

Report Documentation Page

Form Approved
OMB No. 0704-0188

Public reporting burden for the collection of information is estimated to average 1 hour per response, including the time for reviewing instructions, searching existing data sources, gathering and maintaining the data needed, and completing and reviewing the collection of information. Send comments regarding this burden estimate or any other aspect of this collection of information, including suggestions for reducing this burden, to Washington Headquarters Services, Directorate for Information Operations and Reports, 1215 Jefferson Davis Highway, Suite 1204, Arlington VA 22202-4302. Respondents should be aware that notwithstanding any other provision of law, no person shall be subject to a penalty for failing to comply with a collection of information if it does not display a currently valid OMB control number.

1. REPORT DATE DEC 1988	2. REPORT TYPE	3. DATES COVERED 00-00-1988 to 00-00-1988			
4. TITLE AND SUBTITLE Frequency and Time Synchronization in Digital Communications Networks		5a. CONTRACT NUMBER			
		5b. GRANT NUMBER			
		5c. PROGRAM ELEMENT NUMBER			
6. AUTHOR(S)		5d. PROJECT NUMBER			
		5e. TASK NUMBER			
		5f. WORK UNIT NUMBER			
7. PERFORMING ORGANIZATION NAME(S) AND ADDRESS(ES) Nippon Telegraph and Telephone Corporation, 1-2356, Take, Yokosuka-shi, Kanagawa 23 8-03, Japan,		8. PERFORMING ORGANIZATION REPORT NUMBER			
9. SPONSORING/MONITORING AGENCY NAME(S) AND ADDRESS(ES)		10. SPONSOR/MONITOR'S ACRONYM(S)			
		11. SPONSOR/MONITOR'S REPORT NUMBER(S)			
12. DISTRIBUTION/AVAILABILITY STATEMENT Approved for public release; distribution unlimited					
13. SUPPLEMENTARY NOTES See also ADA217145. Proceedings of the Twentieth Annual Precise Time and Time Interval (PTTI) Applications and Planning Meeting, Vienna, VA, 29 Nov - 1 Dec 1988					
14. ABSTRACT see report					
15. SUBJECT TERMS					
16. SECURITY CLASSIFICATION OF:			17. LIMITATION OF ABSTRACT Same as Report (SAR)	18. NUMBER OF PAGES 9	19a. NAME OF RESPONSIBLE PERSON
a. REPORT unclassified	b. ABSTRACT unclassified	c. THIS PAGE unclassified			

node by node. Jitter is caused by digital circuits and the digital signal configuration itself. It decreases if higher hierarchies are used for frequency distribution. However, wander depends on frequency distribution length, and cannot decrease except when transmission line media are changed.

To reduce wander, a positive wander correction is suggested. The correction can be achieved by assuming half of the measured round trip delay. Experimental results of delay variation in NTT's existing network are shown.

2. NETWORK SYNCHRONIZATION IN NTT

2.1 Basic configuration

NTT has adopted master-slave synchronization. The configuration of NTT's network synchronization is shown in Fig. 1. There are two master nodes in the first stage, and many slave nodes, each of which contains a slave clock system. The Tokyo node is the original master during normal operation[3]. The Osaka node is the backup. Two paths are usually selected for clock distribution: a primary and a secondary path. In the second stage, one path is from the Tokyo node, and the other is from the Osaka node. In the following stages, the clock distribution paths are selected from among different nodes if possible.

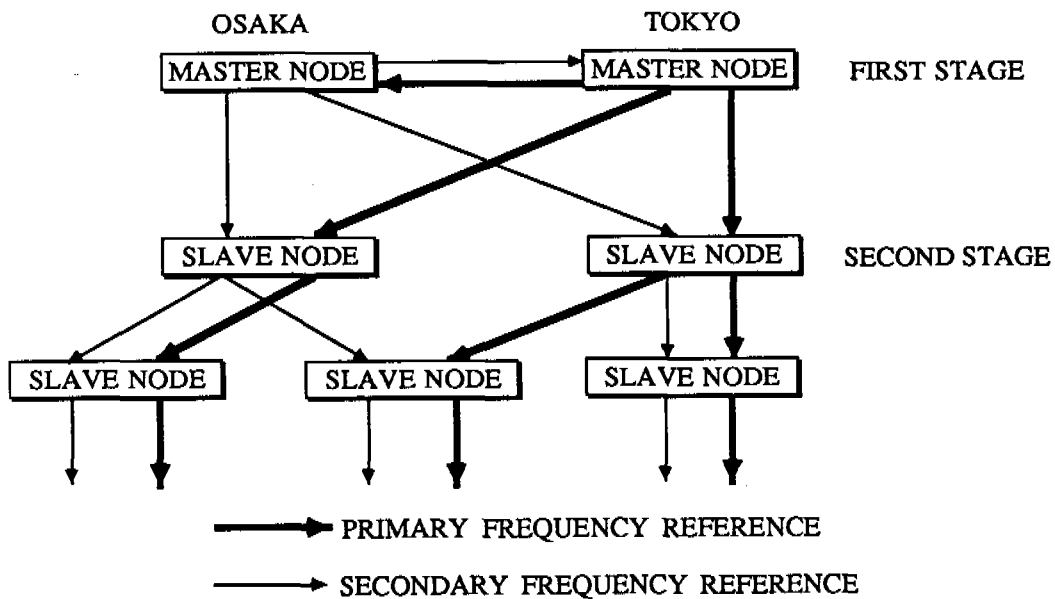

Fig. 1 NTT NETWORK SYNCHRONIZATION

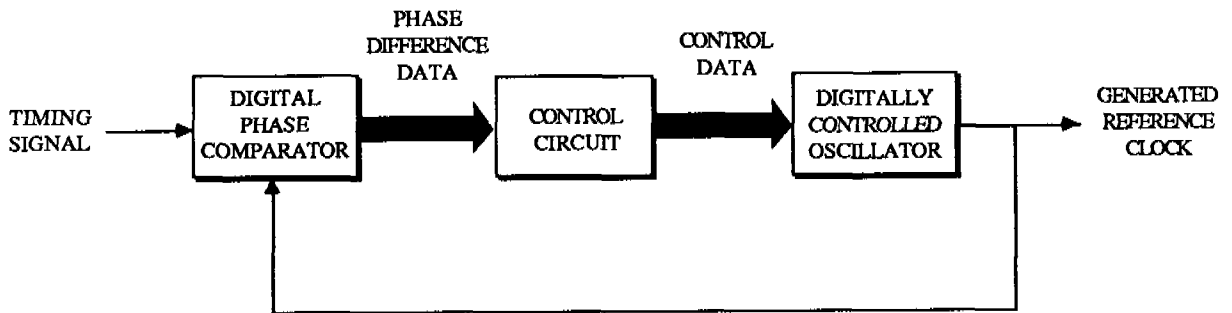

Fig. 2 BASIC CONFIGURATION OF SLAVE CLOCK SYSTEM

2.2 Design of the slave clock system

A block diagram of the slave clock system is shown in Fig. 2. The basic configuration of the slave clock system is a phase-locked loop (PLL). The timing signal from the higher level slave node or from the master node is input to a phase comparator. The PLL locks to this timing signal, and generates the new reference clock. In the new slave clock system, a Rubidium atomic oscillator is used, and it is digitally controlled. The frequency control resolution of the Rubidium atomic oscillator is better than 10^{-12} . Therefore, the output frequency deviation is kept on the order of 10^{-12} , even if the input timing signal fails.

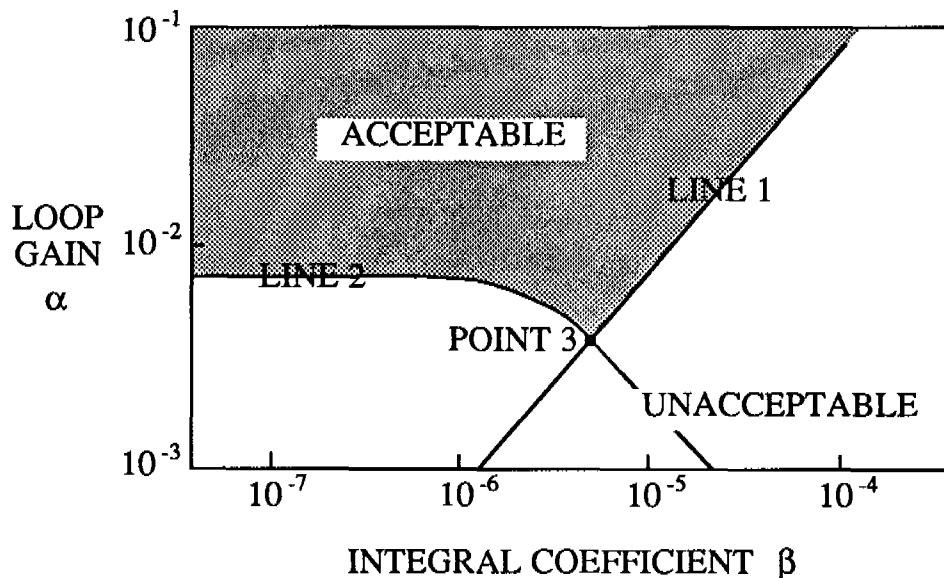

Fig. 3 ACCEPTABLE COMBINATION OF LOOP GAIN AND INTEGRAL COEFFICIENT

The time constant is an important parameter in PLLs, since it determines the budget of reduced and traced frequency components. If a loop filter is a perfect integral plus proportional filter, the PLL time constant is determined by loop gain and integral coefficient values. A PLL with a perfect integral plus proportional filter has the advantage of a constant steady state phase error. However, there are frequency areas that amplify noises. Therefore, to restrict the gain of the amplitude, the coefficients must have values as represented by the area to the left of line 1 shown in Fig. 3. In addition, the PLL should trace the input timing signal to reduce oscillator frequency deviations such as those caused by temperature dependence. Thus, the area above line 2 in Fig. 3 represents acceptable loop gain values. Since lower loop gain means better input noise reduction, point 3 in Fig. 3 is the optimum combination of values.

If the frequency control resolution of a variable frequency oscillator is upgraded to improve the frequency holdover characteristics, the loop gain becomes lower. Generally the loop gain is lower than the optimum point. To increase the loop gain, the resolution of the phase difference detection at the phase comparator has to be improved. However, the resolution of the digital phase difference detection is limited by processing speed in the digital circuits. Therefore, to vary the loop gain, it is suggested to change the frequency control resolution without degradation of the frequency holdover characteristics. The control algorithm of the variable frequency oscillator is shown in Fig. 4. In this algorithm, two resolutions of frequency control are used. One is selected to be N times as many as the minimum frequency control resolution. This allows increasing the time constant. The other is selected to be the minimum frequency control resolution for the frequency holdover so that the holdover frequency deviation is decreased. The control data for the holdover operation consists of the filtered normal operation data. In Fig. 4, N is given value of 4.

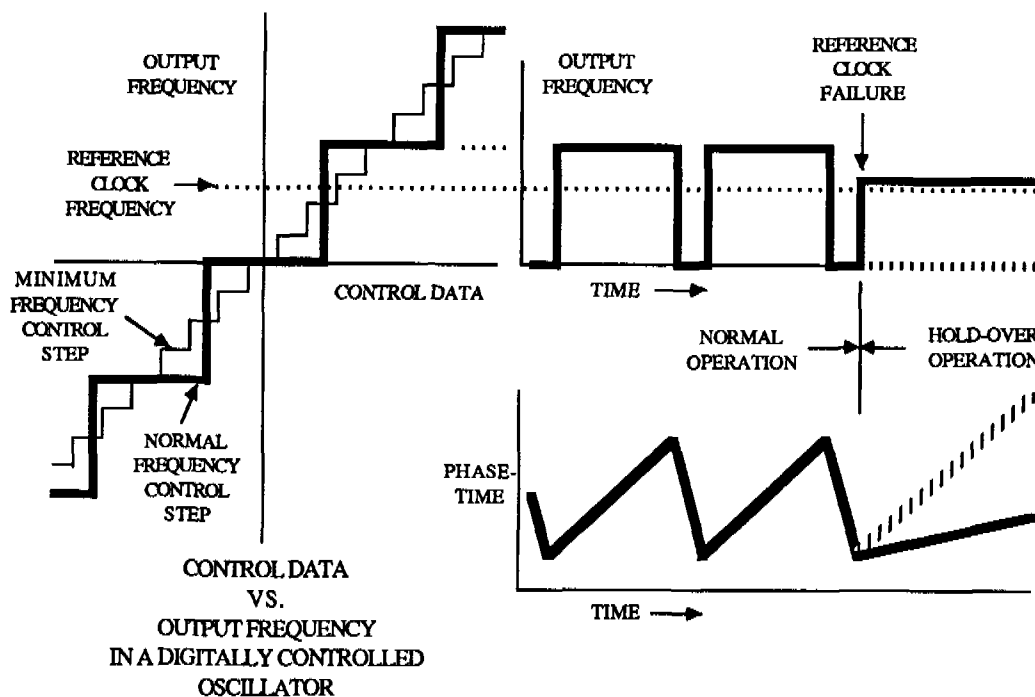

Fig. 4 PLL CONTROL ALGORITHM

2.3 Reference clock performance

The transfer function of a PLL is shown in Fig. 5, and the output gain for the variable frequency oscillator of a PLL in a slave node is shown in Fig. 6. The optimum values are selected as PLL loop parameters. The black points show the actual measurement results, and the line shows the theoretical values. The cutoff frequency is 4.17×10^{-4} Hz, which corresponds to a time constant of about 2,000 s.

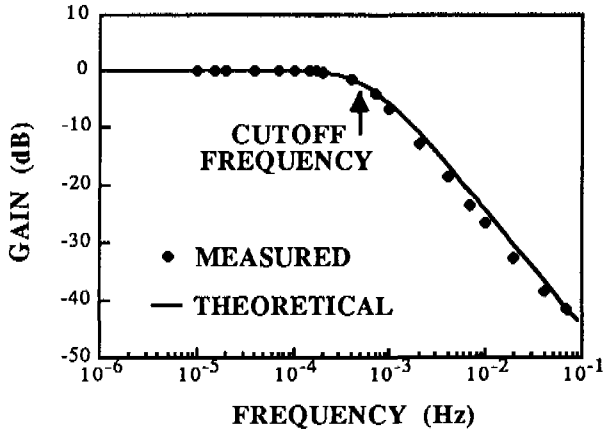

Fig. 5 TRANSFER FUNCTION OF PLL IN THE SLAVE NODE

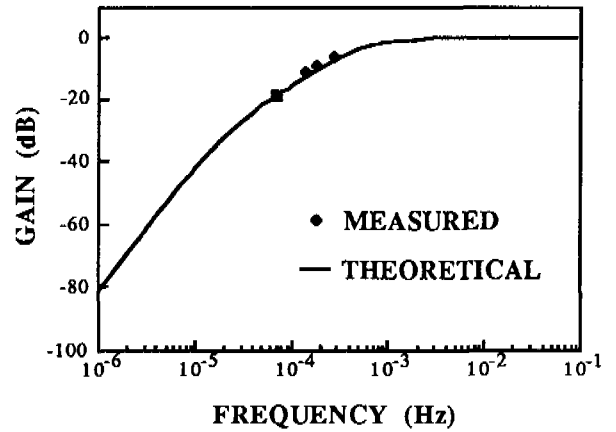

Fig. 6 OUTPUT GAIN FOR THE VARIABLE FREQUENCY OSCILLATOR OF PLL IN THE SLAVE NODE

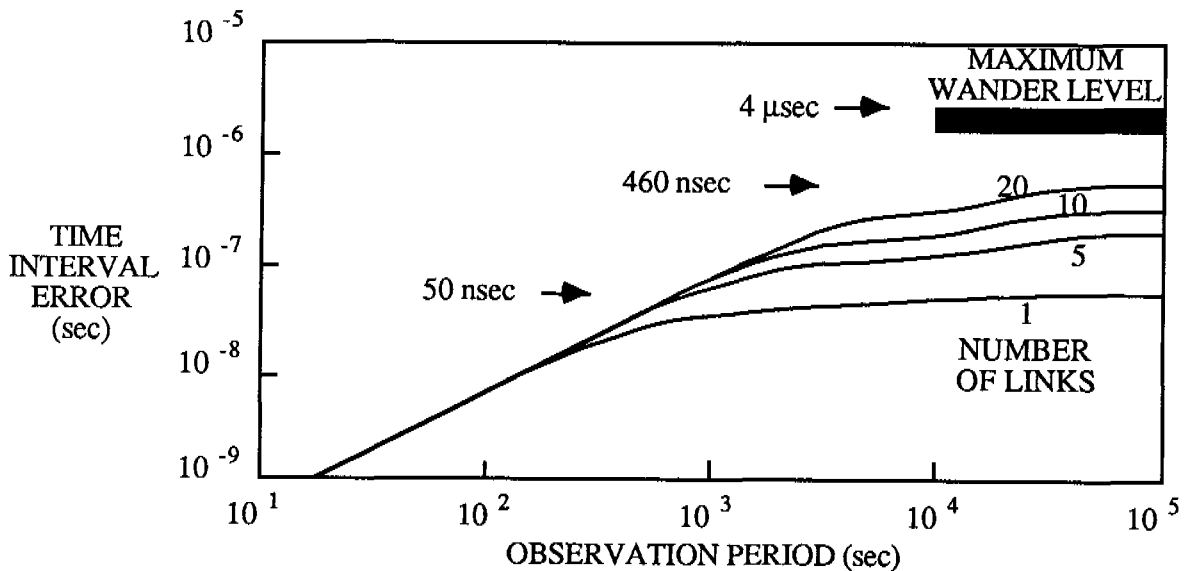

Fig. 7 TIME INTERVAL ERROR OF THE REFERENCE CLOCK

Assuming the PLL characteristics shown in Figs. 5 and 6, the phase-time variation of the slave node outputs is calculated as shown in Fig. 7. The X-axis here is the observation period, and the y-axis is the time interval error, which corresponds to phase-time variation. The time interval error per link of the slave node is within 50 ns. That means a frequency distribution capability of 5×10^{-13} over the observation period of 10^5 s. The maximum time interval error is 460 ns. The maximum number of links is assumed to be 20. These error values represent a reduction to one 20th compared with the error values in NTT's previous network synchronization scheme employing an arbitrary time constant.

Actually, phase-time variation over a long period, called wander, should be considered. The maximum wander is estimated to be 4 μ s in NTT's network. This value satisfies the recommended characteristics in CCITT.

3. TIME TRANSFER IN DIGITAL COMMUNICATIONS NETWORKS

3.1 Basic method

The maximum phase-time variation of 4 μ s indirectly means frequency distribution makes it possible to provide a relative time transfer accuracy of 4 μ s. Next, a method is presented for positive time transfer. Time transfer from a reference time node to a slave time node with a digital path like the master-slave technique for the frequency distribution is shown at the top of Fig. 8. The path delay is necessary to correct the transferred reference time. A basic simple technique to determine the path delay is to assume half of measured round trip delay, as shown at the bottom of Fig. 8.

This method is based on the assumption that the delay of the outgoing path is identical with that of the incoming path. However, actual transmission paths are not constructed to guarantee this. Therefore, consider here the correction of the path delay variation instead of the path delay itself. In this case, the outgoing path delay variation can be assumed with measurement of round trip delay variation. If the delay variation of the outgoing path is identical with that of the incoming path, the outgoing path delay variation is half the delay variation of the round trip path. This is positive wander correction.

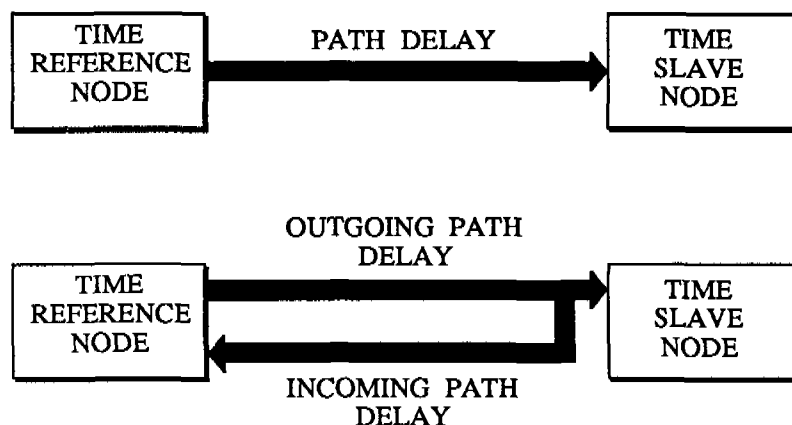

Fig. 8 BASIC TIME TRANSFER

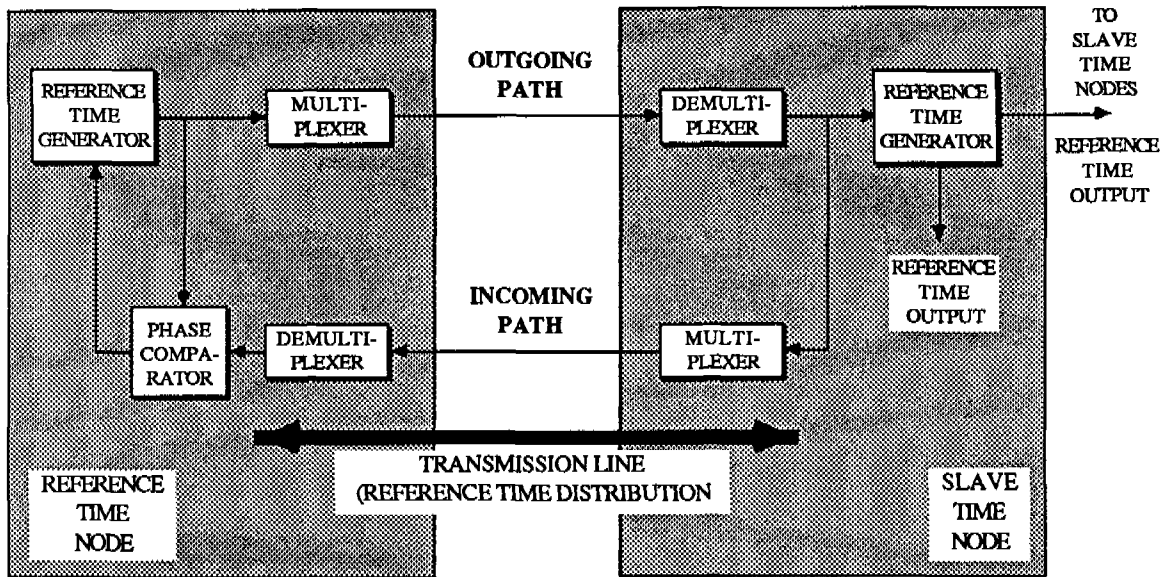

Fig. 9 ROUND TRIP PATH MEASUREMENT CONFIGURATION

The configuration for the actual round trip measurement is shown in Fig. 9. The reference time signal is transferred over the outgoing path from the left side, the time reference node, to the right side, the time slave node. The slave node returns a reference time signal over the incoming path. The delay variation of the round trip path is measured by the phase comparator.

The delay variation of the outgoing path can be estimated to be half the delay variation of the round trip path. This variation corresponds to the correction value for the transferred reference time in the slave time node.

3.2 Time transfer capability

To test the feasibility of the method mentioned above, phase-time variations of both the outgoing and incoming path are measured simultaneously. Figure 10 shows the delay variation of each path for 17 days in the existing NTT's network. Its total transmission length was 2,291 km. The Y-axis is phase-time, and its absolute value is arbitrary. The delay changes about 150 ns over 17 days. However, Fig. 10 shows that the delay variation of the outgoing path is essentially the same as that of the incoming path. This implies that delay variation tendencies are essentially the same in the same transmission line, even if delays are not the same.

It is effective to subtract the delay variation of the outgoing from that of the incoming path in order to confirm this correlation. The differential data is shown at the top of Fig. 11. The bottom of Fig. 11 is the filtered data. The most significant feature is that the average differential delay value is not divergent but constant. This means that the initial phase-time can be controlled and kept constant.

The square root of the two-sample variance of the differential delay variation is

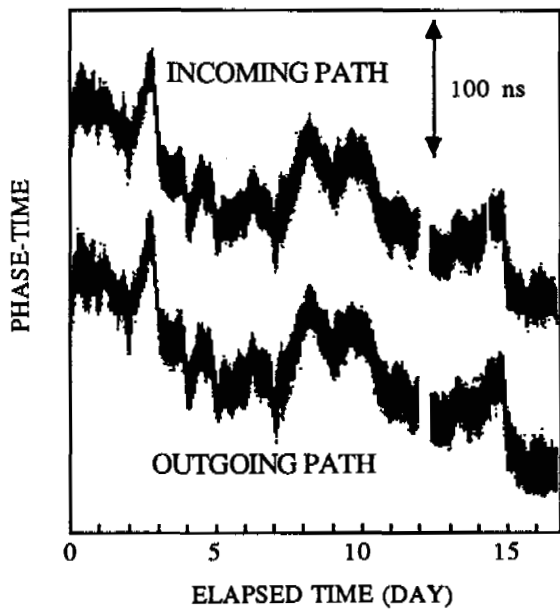

Fig. 10 DELAY VARIATION OF TRANSMISSION LINES

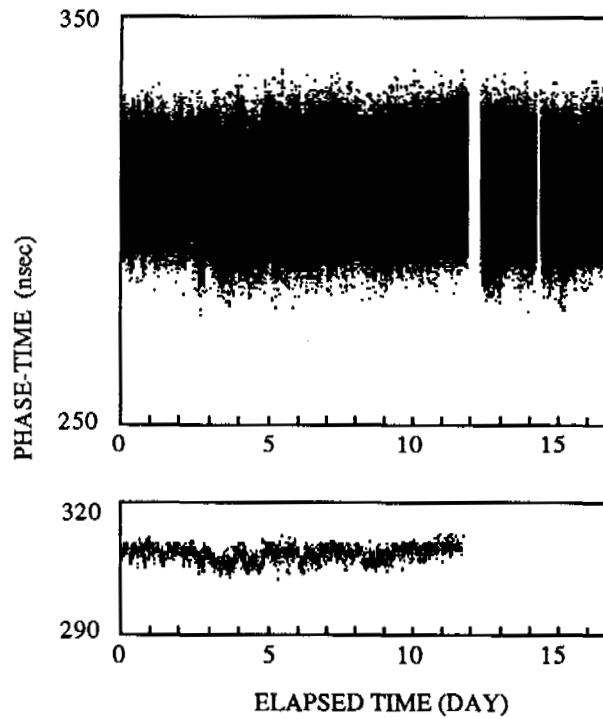

Fig. 11 DELAY VARIATION OF THE SUBTRACTION DATA

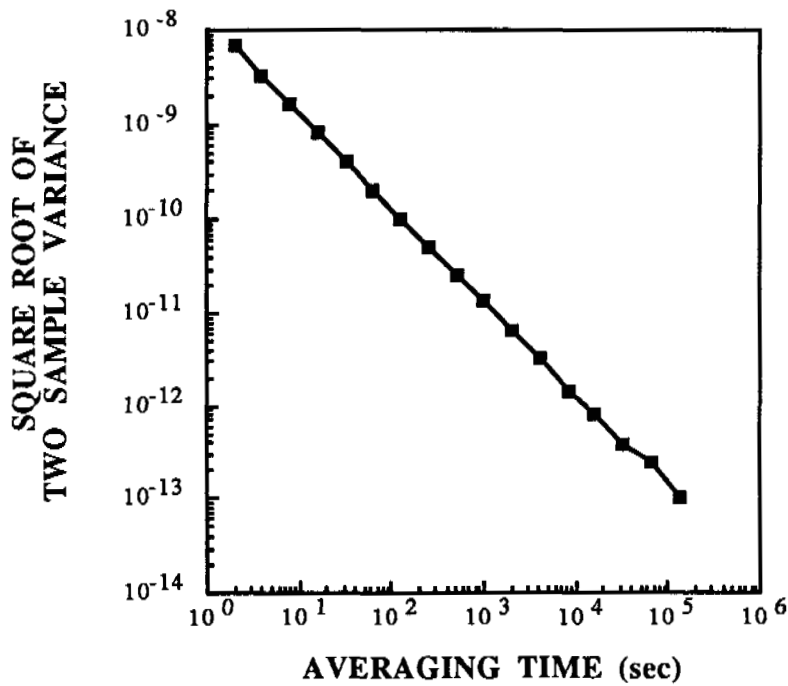

Fig. 12 STABILITY OF TRANSMISSION LINES

10^{-13} over the averaging time of 10^5 s, as shown in Fig. 12. This corresponds to about 10 ns in phase-time. The variation tends to be white phase noise up to the averaging time of 10^5 s.

4. CONCLUSION

The experimental results mean the time transfer capability of this wander correction method is 10 to 30 ns/link. Considering the frequency distribution characteristics and the multi-link of time slave nodes, the total relative time accuracy is within 500 ns.

If this time transfer method could be combined with an initial absolute time setting such as by using portable clocks, the absolute time scale tracing UTC might be provided. We have been developing a portable optically pumped cesium beam standard[4]. The portable clock method employing this oscillator is expected to have an accuracy on the order of 10 ns. The time accuracy in NTT's digital networks is expected to 100 ns to 600 ns.

ACKNOWLEDGEMENTS

We are grateful to Dr. Masaki Koyama and Mr. Katsuaki Kikuchi of NTT Transmission Systems Laboratories for their encouragement. We would like to thank Mr. Ken-ichiro Kuroishi of NTT Sapporo Network Center for his help with the experiments.

REFERENCES

- [1] H. Ueda and I. Tokizawa, "A Aynchronous DS4 Multiplexer with Cross-connect Function and Its Impact on the Network", GLOBECOM'85, 1985
- [2] CCITT Recommendations, Recs. G. 811, G. 812, G. 824 and G.825, AP IX-150
- [3] M. Kihara and H. Jumonji, "Frequency Keeping Algorithm for Atomic Reference Frequency and Clock Supply", Elect. and Comm. in Japan, Vol. 66-B, No. 11, pp. 76-84, Nov. 1983
- [4] M. Kihara and K. Hisadome, "Design of High Performance, Portable Optically Pumped Cesium Beam Standards", CPEM'88, pp.248-249, 1988