



AATD TR10-D-87



TECHNOLOGY DRIVEN. WARFIGHTER FOCUSED.

Composite Universal Weapons Pylon Fatigue Test Report

Jay P. Kiser II

Aviation Applied Technology Directorate
US Army RDECOM, AMRDEC
RDMR-AAF
Fort Eustis, VA 23604-5577

07 May 2010

DISTRIBUTION STATEMENT

Approved for public release; distribution unlimited.

REPORT DOCUMENTATION PAGE

Form Approved
OMB No. 0704-0188

Public reporting burden for this collection of information is estimated to average 1 hour per response, including the time for reviewing instructions, searching existing data sources, gathering and maintaining the data needed, and completing and reviewing this collection of information. Send comments regarding this burden estimate or any other aspect of this collection of information, including suggestions for reducing this burden to Department of Defense, Washington Headquarters Services, Directorate for Information Operations and Reports (0704-0188), 1215 Jefferson Davis Highway, Suite 1204, Arlington, VA 22202-4302. Respondents should be aware that notwithstanding any other provision of law, no person shall be subject to any penalty for failing to comply with a collection of information if it does not display a currently valid OMB control number. **PLEASE DO NOT RETURN YOUR FORM TO THE ABOVE ADDRESS.**

1. REPORT DATE (DD-MM-YYYY) 07 May 2010		2. REPORT TYPE Fatigue Test Report		3. DATES COVERED (From - To) March 2010 - April 2010	
4. TITLE AND SUBTITLE Composite Universal Weapons Pylon Fatigue Test Report				5a. CONTRACT NUMBER W911W6-08-D-0008	
				5b. GRANT NUMBER	
				5c. PROGRAM ELEMENT NUMBER	
6. AUTHOR(S) Mr. Jay P. Kiser II				5d. PROJECT NUMBER	
				5e. TASK NUMBER	
				5f. WORK UNIT NUMBER	
7. PERFORMING ORGANIZATION NAME(S) AND ADDRESS(ES) Aviation Applied Technology Directorate Building 401, Lee Blvd RDMR-AAF Fort Eustis, VA 23604-5577				8. PERFORMING ORGANIZATION REPORT NUMBER TR10-D-87	
9. SPONSORING / MONITORING AGENCY NAME(S) AND ADDRESS(ES)				10. SPONSOR/MONITOR'S ACRONYM(S)	
				11. SPONSOR/MONITOR'S REPORT NUMBER(S)	
12. DISTRIBUTION / AVAILABILITY STATEMENT Approved for public release; distribution unlimited.					
13. SUPPLEMENTARY NOTES					
14. ABSTRACT The fatigue testing of the OH-58D Composite Universal Weapons Pylon (CUWP) was accomplished in accordance with Composite Universal Weapons Pylon Fatigue Test Plan. Fatigue testing of the CUWP commenced 12 March 2010 and was completed 01 April 2010. The CUWP successfully met the cyclic, stiffness, and proof load requirements of the test plan. Visual inspection of the CUWP prior to testing and after all load applications were completed showed that no visible damage was introduced into the test article.					
15. SUBJECT TERMS Fatigue, composite, test					
16. SECURITY CLASSIFICATION OF:			17. LIMITATION OF ABSTRACT	18. NUMBER OF PAGES	19a. NAME OF RESPONSIBLE PERSON
a. REPORT UNCLASSIFIED	b. ABSTRACT UNCLASSIFIED	c. THIS PAGE UNCLASSIFIED			Mr. Jay P. Kiser II
				17	19b. TELEPHONE NUMBER (include area code) 757-878-7084



References

- a. Energy Impact of the Composite Universal Weapons Pylon, 23 March 2010
- b. Pre-Test Visual Inspection of the Composite Universal Weapons Pylon, 10 February 2010
- c. Post-Test Visual Inspection of the Composite Universal Weapons Pylon, 16 April 2010

Appendices

1. Composite Universal Weapons Pylon Fatigue Test Plan, 10 March 2010 (Base)
2. Composite Universal Weapons Pylon Fatigue Test Plan, 22 March 2010 (Revision 1)

Executive Summary

The fatigue testing of the OH-58D Composite Universal Weapons Pylon (CUWP) was accomplished in accordance with Appendices (1) and (2). Fatigue testing of the CUWP commenced 12 March 2010 and was completed 01 April 2010. The test program was executed at the Aviation Applied Technology Directorate (AATD) at Fort Eustis, Virginia. The CUWP successfully met the cyclic, stiffness, and proof load requirements of the test plan. Visual inspection of the CUWP prior to testing and after all load applications were completed showed that no visible damage was introduced into the test article.

Test Program Execution

The testing was conducted by:

Jay Kiser	AATD, Platform Technology	(757) 878-7084
Tim Davis	AATD, Test and Instrumentation	(757) 878-3303
Gordon Higgins	AATD, Test and Instrumentation	(757) 878-3303
Kent Carpenter	AATD, Test and Instrumentation	(757) 878-3303
Wade Jackson	NASA Langley Research Center	(757) 864-3468

Witnessing the testing was:

Kris Kuck	AATD, Systems Integration	(757) 878-3649
-----------	---------------------------	----------------

Summary of the Load Cases

Testing was accomplished in two blocks, 12-15 March 2010 and 29 March – 01 April 2010, respectively (Table 1). There was a 14 day break between the first and the second blocks of testing in order to arrange for the test article to be subjected to the 5 ft-lbs of energy impacts required by Appendix (2).



Table 1. CUWP Fatigue Test Dates and Environmental Conditions

Test Description	Date	Time	Temp (°F)	% Humidity
Stiffness Check #1	12-Mar-2010	8:00	71.8	51.2
Load Case #1a	12-Mar-2010	9:45	66.4	74.5
Stiffness Check #2	12-Mar-2010	11:00	66.6	75.2
Load Case #2a	12-Mar-2010	11:30	64.5	80.6
Stiffness Check #3	15-Mar-2010	7:30	68.6	47.6
Load Case #3a	15-Mar-2010	8:00	69.3	46.8
Stiffness Check #4	15-Mar-2010	12:30	70.3	44.1
Proof Load #1a	15-Mar-2010	13:30	70.7	43.4
Proof Load #2a	15-Mar-2010	14:50	67.1	48.1
Stiffness Check #5	29-Mar-2010	12:30	71.2	53.4
Load Case #1b	29-Mar-2010	13:00	72.1	53.2
Stiffness Check #6	29-Mar-2010	15:30	72.6	53.5
Load Case #2b	29-Mar-2010	16:00	72.6	53.5
Stiffness Check #7	31-Mar-2010	8:00	71.1	31.8
Load Case #3b	31-Mar-2010	8:15	71.4	31.8
Stiffness Check #8	1-Apr-2010	8:20	69.9	43.3
Proof Load #1b	1-Apr-2010	8:40	69.9	42.7
Proof Load #2b	1-Apr-2010	9:20	70.4	41.6

Stiffness Checks 1-4

Prior to each load case, the CUWP test article was subjected to a stiffness check in order to determine if any variations in stiffness occurred during the cyclic loading. The stiffness checks consisted of one stroke up to a load limit of 700-lbs. Load as a function of displacement was recorded for each of the first four stiffness checks (Figure 1). The stiffness of the test setup generally increased as more stiffness checks were performed. This was likely due to the interface of the collet assembly and the lower test fixture. Tightening the collet nut expanded the collet providing a frictional interface between the collet and the test fixture. When the test article was subjected to cyclic loading, the collet had the tendency to seat into the fixture. As more cyclic loading was performed, more seating took place. Since the collet nut was re-torqued to the required 250-260 ft·lbs prior to each stiffness check, it is logical to conclude that the changing stiffness of the test setup was the result of the increased seating of the collet.

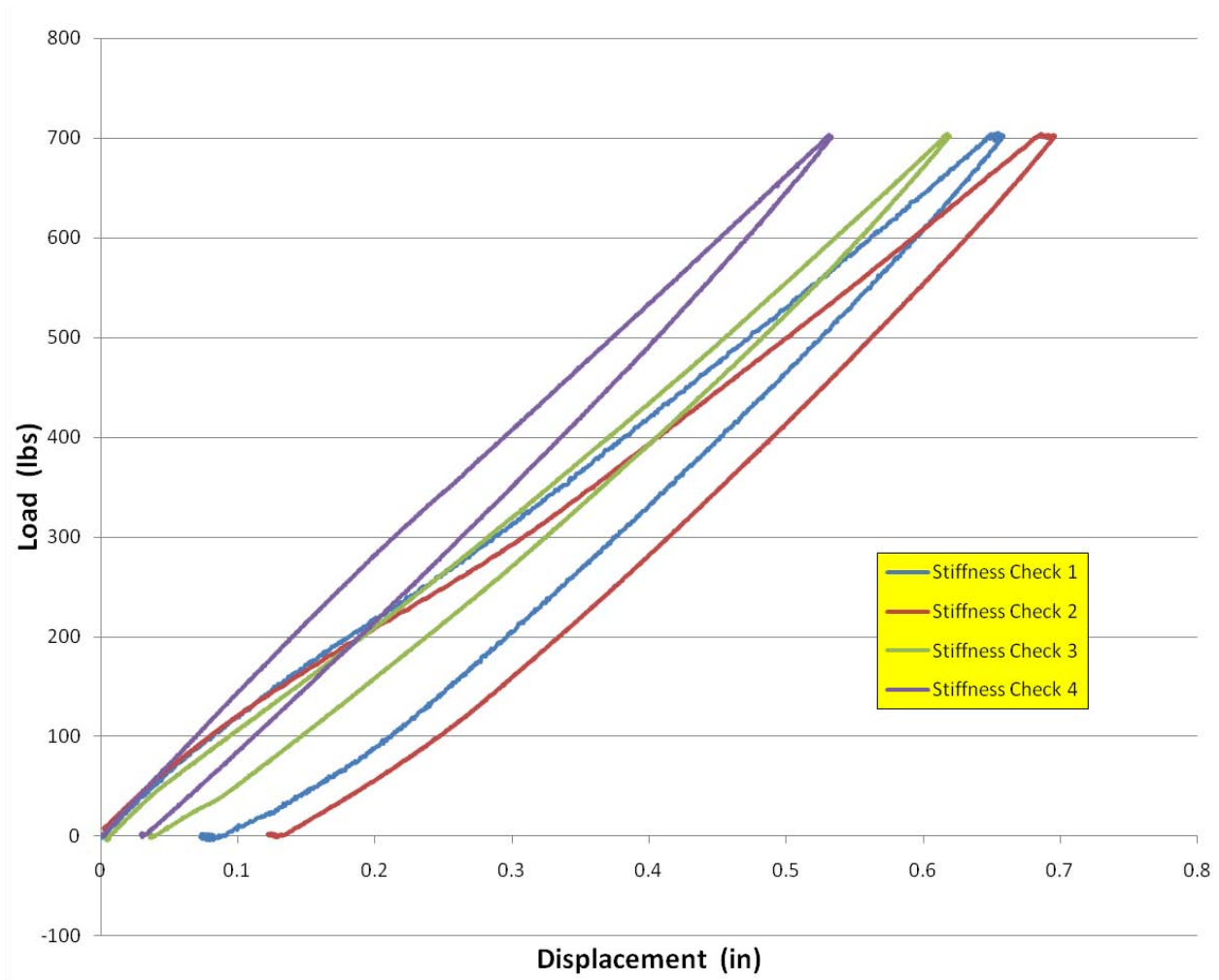

Figure 1. Load vs. Displacement for Stiffness Checks 1-4

Cyclic Load Case #1a

Cyclic Load Case #1a simulated the firing of HELLFIRE missiles for 4,200 cycles. Load as a function of time for Cyclic Load Case #1a was recorded (Figure 2). The cyclic loading was performed at two hertz. The hydraulic actuator and load cell was subjected to displacement control thus the maximum and minimum displacement values were -0.96" and -0.20", respectively. The load curves are smooth indicating that no anomalies were recorded.

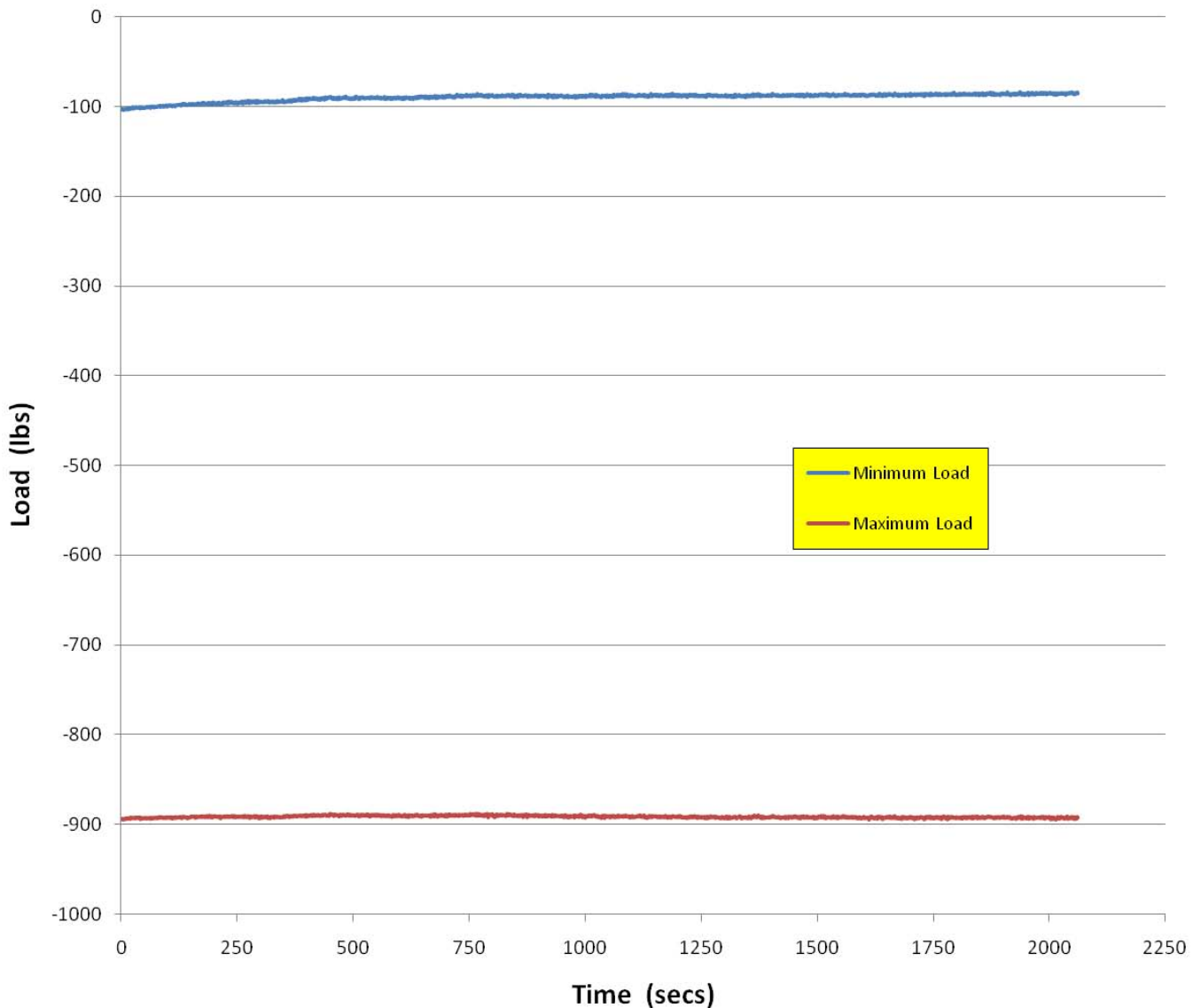

Figure 2. Cyclic Load vs. Time, Case #1a

Cyclic Load Case #2a

Cyclic Load Case #2a simulated the firing of a .50 caliber machine gun for 420,000 cycles. Load as a function of time for Cyclic Load Case #2a was recorded (Figure 3). The cyclic loading was performed at four hertz. The hydraulic actuator and load cell was subjected to displacement control thus the maximum and minimum displacement values were 0.61" and 0.18", respectively. There was a slight reduction in maximum load and a corresponding increase in minimum load approximately 28,000 seconds into the test. These variations may be attributed to a slight slippage of the support structure and/or the collet seating. The minimum load that was recorded during this load case was 671 lbs, which is within the allowable 5% load tolerance per the test plan. Other than this variance, the load curves are smooth indicating that no anomalies were recorded.

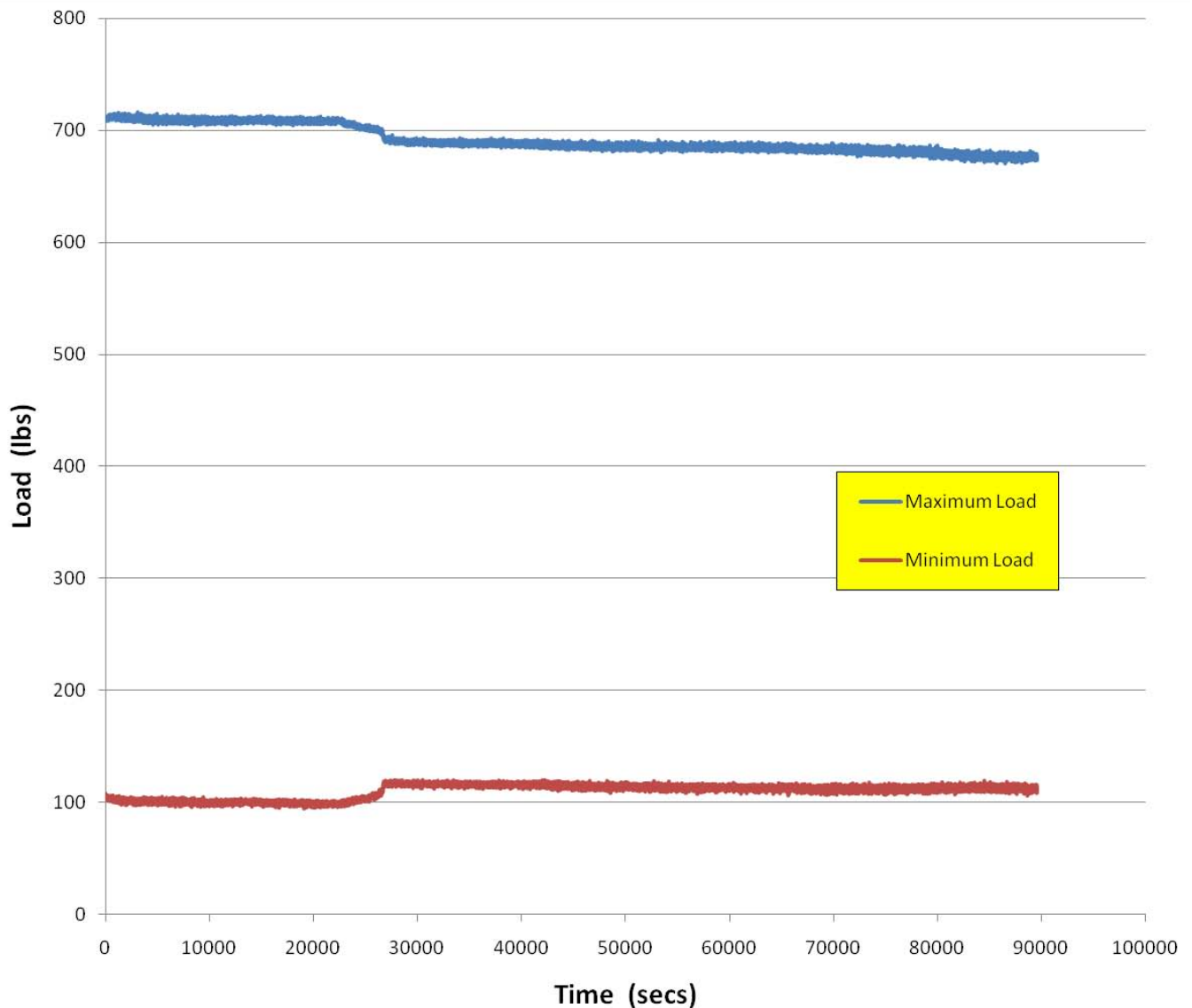

Figure 3. Cyclic Load vs. Time, Case #2a

Cyclic Load Case #3a

Cyclic Load Case #3a simulated the firing of Hydra rockets for 42,000 cycles. Load as a function of time for Cyclic Load Case #3a was recorded (Figure 4). The cyclic loading was performed at three hertz. The hydraulic actuator and load cell was subjected to displacement control thus the maximum and minimum displacement values were 1.04" and 0.22", respectively. The load curves are smooth indicating that no anomalies were recorded. This completed the first block of cyclic testing.

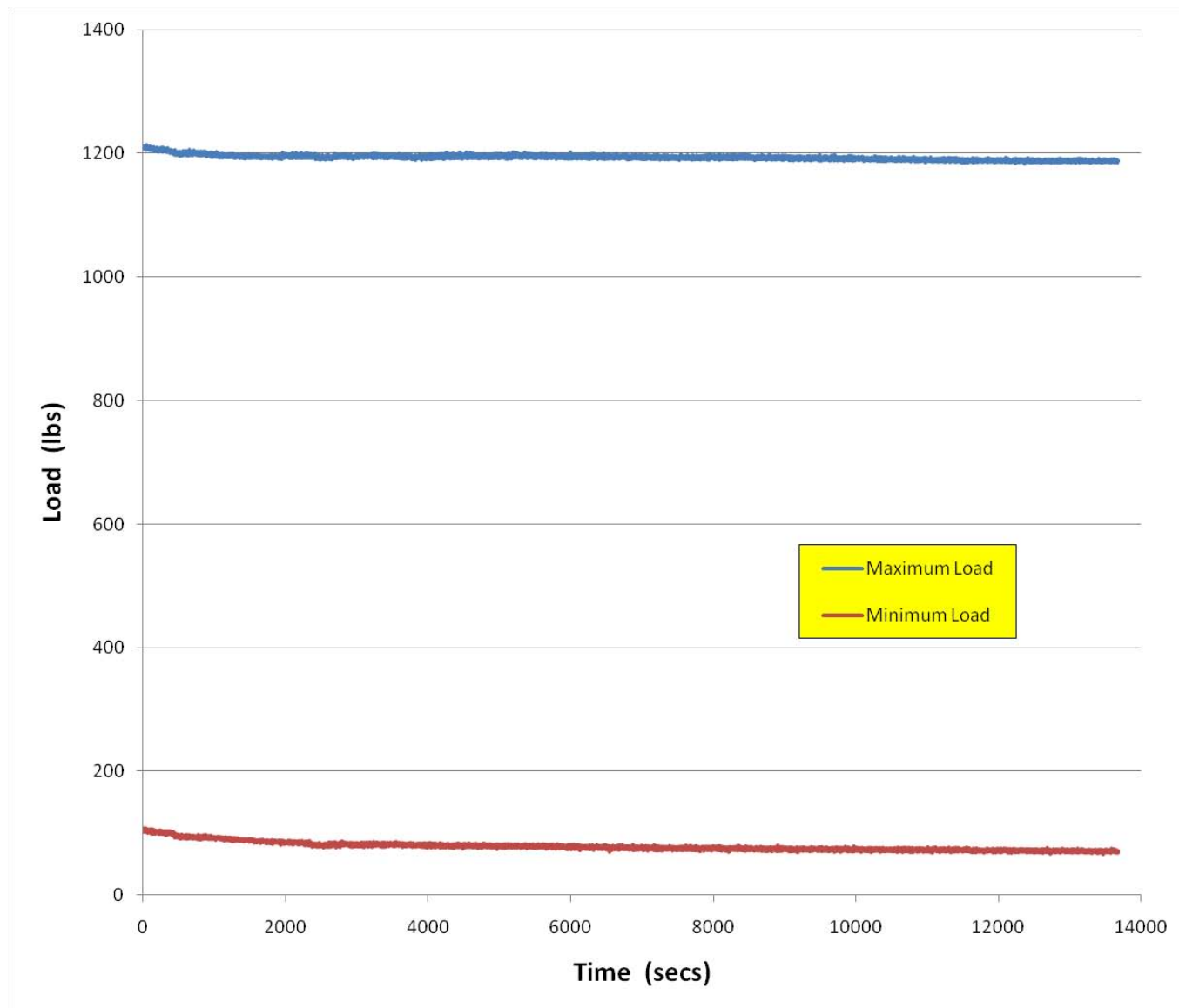

Figure 4. Cyclic Load vs. Time, Case #3a

Proof Load Case #1a

Proof Load Case #1a simulates Hydra rocket loading and was conducted to demonstrate no stiffness or strength reduction occurred in the test article after the completion of the of the first block of cyclic loading. Load as a function of displacement was recorded for Proof Load Case #1a (Figure 5). The load was applied with a 120 second ramp up duration, held constant for 30 seconds, and then released with a 120 second ramp down duration. The test article underwent elastic hysteresis but did not return to exactly zero displacement. In addition, there was a slight increase in displacement during the 30 second duration when the load was held constant. This may have been the result of the test article experiencing slip, a slippage of the support structure, and/or the collet seating. Regardless, the displacement variations can be considered negligible for the purposes of this test since the 1800-lbs proof load was conducted to show that the test article could hold 1.5 times the Hydra rocket load after cyclic loading without structural failure.

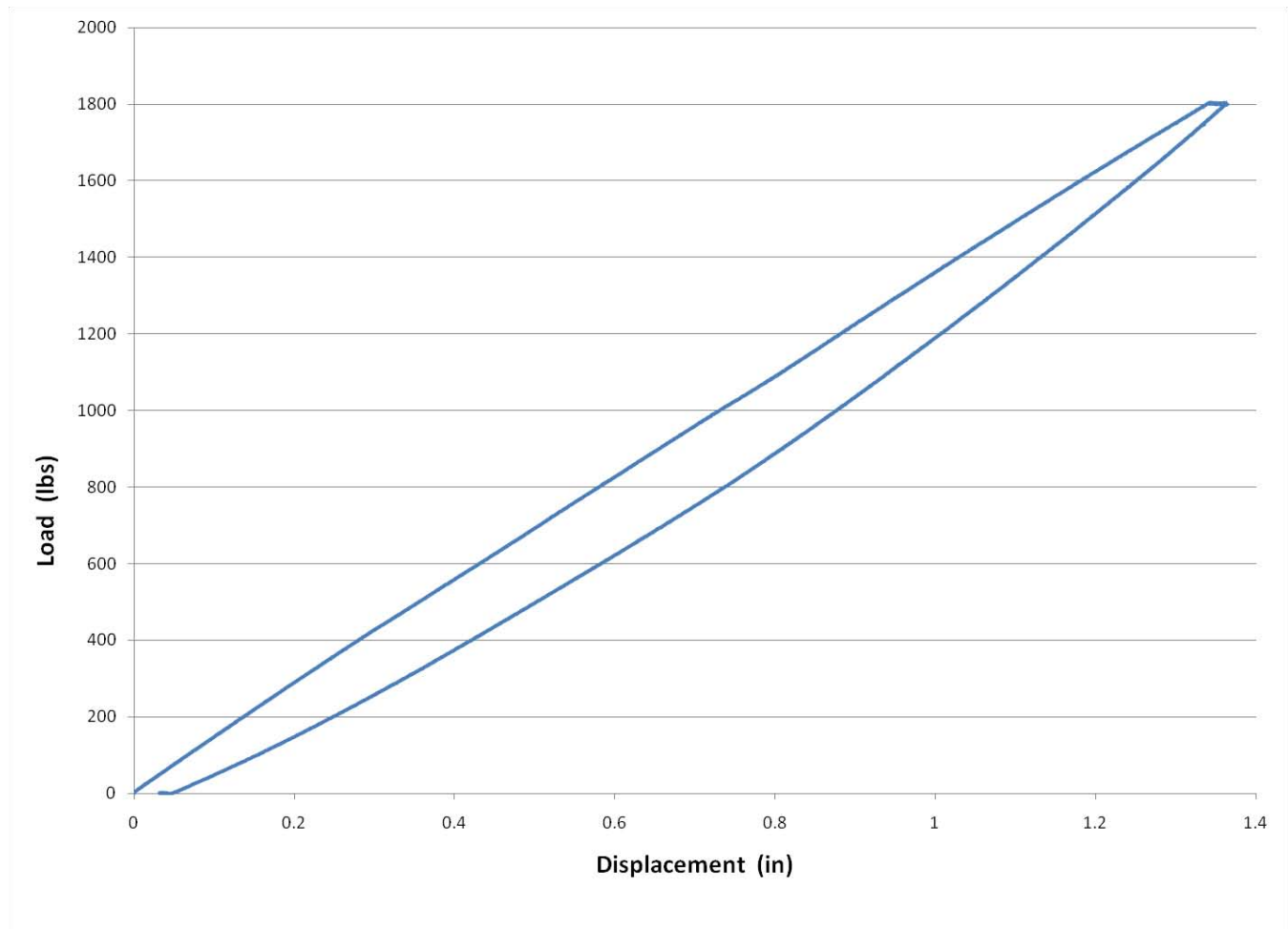

Figure 5. Load vs. Displacement, Proof Load Case #1a

Proof Load Case #2a

Proof Load Case #2a simulates HELLFIRE missile loading and was conducted to demonstrate no stiffness or strength reduction occurred in the test article after the completion of the of the first block of cyclic loading. Load as a function of displacement was recorded for Proof Load Case #2a (Figure 6). The load was applied with a 120 second ramp up duration, held constant for 30 seconds, and then released with a 120 second ramp down duration. The test article underwent elastic hysteresis but did not return to exactly zero displacement. In addition, there was a slight increase in displacement during the 30 second duration when the load was held constant. This may have been the result of the test article experiencing slip, a slippage of the support structure, and/or the collet seating. Regardless, the displacement variations can be considered negligible for the purposes of this test since the -1350 lbs proof load was conducted to show that the test article could hold 1.5 times the HELLFIRE missile load after cyclic loading without structural failure.

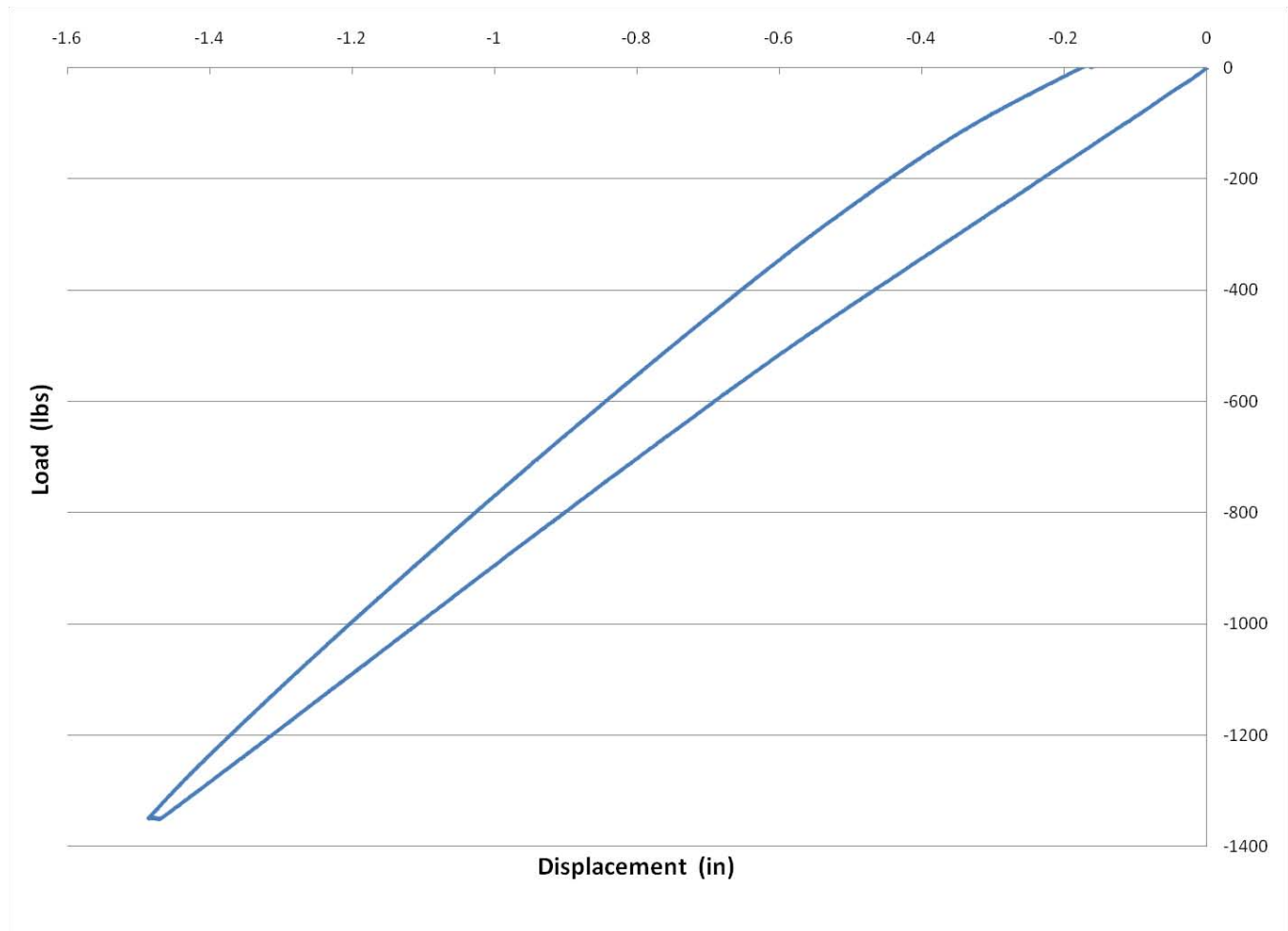

Figure 6. Load vs. Displacement, Proof Load Case #2a

Energy Impacts

After Proof Load Case #2a was completed, the test article was subjected to energy impacts at specific locations in accordance with Appendix (2). The impact locations, impact energy, maximum force, and other pertinent information were recorded (Table 2). The impact delivery device consisted of a spring propelled 3.3 lb impacter with a 0.5" diameter hemispherical tip (Figures 7 and 8). Calculated spring compression and force histories were documented (Reference a).

Table 2⁽¹⁾. CUWP Test Article Energy Impact Data

Impact Location	Calculated Energy (ft·lbs)	Max Force (lbs)	Contact Duration (ms)	Angle Above Horizontal (degrees)	STA, BL, WL (in)
1	5	1412	0.76	39	98.6, -42.30, 36.51
2	6.1	2254	0.93	24	94.10, -35.55, 26.38
3	5	2171	0.79	28	93.10, -31.55, 24.51
4	5	3155	0.76	61	93.60, -27.80, 24.76
5	5	1200	0.77	49	101.60, -41.80, 35.26
6	5	2034	0.93	32	98.10, -34.68, 27.01
7	5	2093	0.81	34	96.48, -31.80, 22.88
8	5	2611	0.83	49	96.35, -27.68, 23.13

(1) Data provided by Mr. Wade Jackson, NASA Langley Research Center, Hampton, Virginia



Figure 7. Impact Delivery Device



Figure 8. Energy Impact at Impact Location 6

Stiffness Checks 5-8

Stiffness checks were again conducted prior to each load case for the second block of testing. Load as a function of displacement was recorded for each of the final four stiffness checks (Figure 9). As was the case with the first four stiffness checks, the stiffness of the test setup generally increased as more stiffness checks were performed.

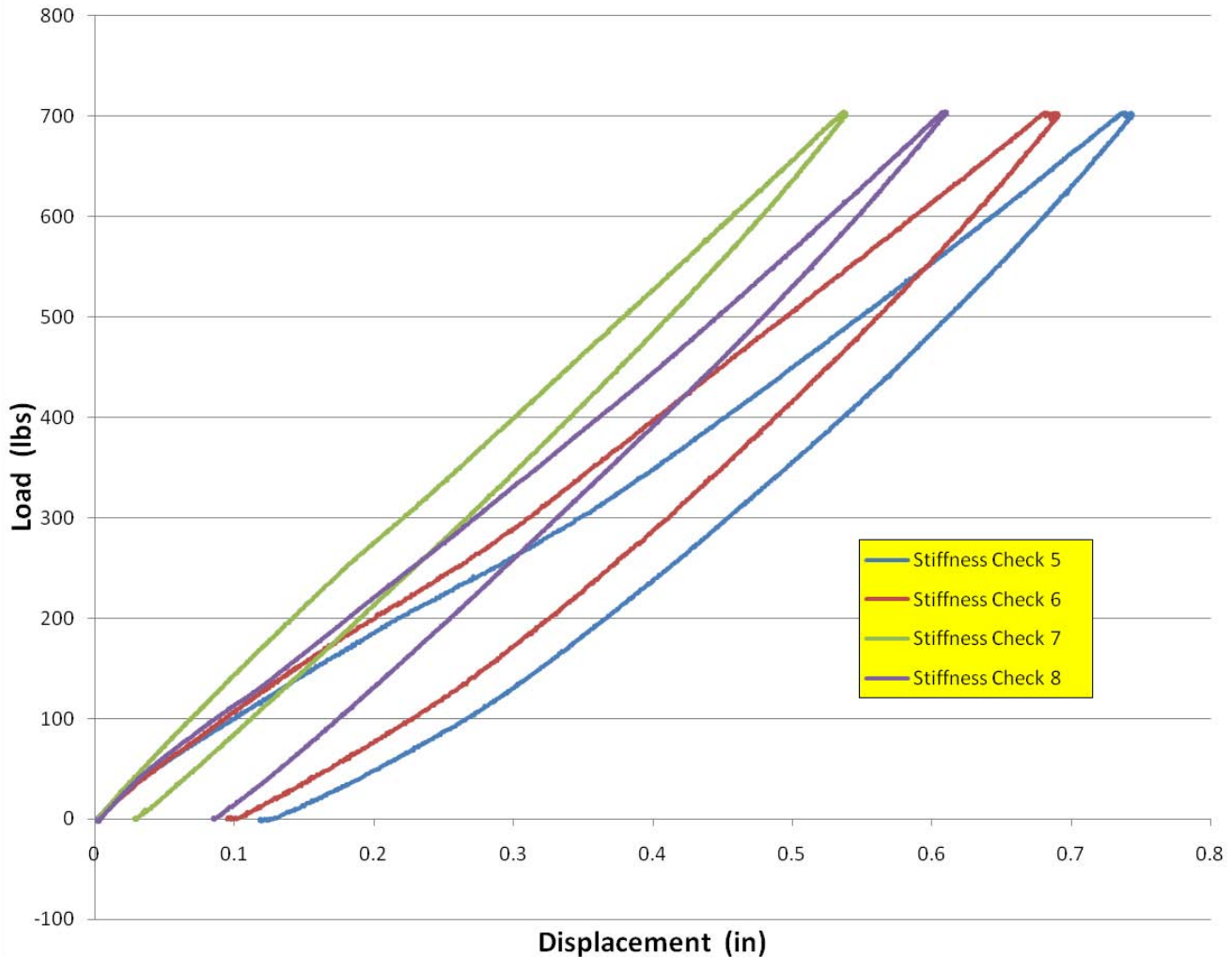

Figure 9. Load vs. Displacement for Stiffness Checks 5-8

Cyclic Load Case #1b

The second cyclic HELLFIRE missiles loading spectrum was applied for 4,200 cycles. Load as a function of time for Cyclic Load Case #1b was recorded (Figure 10). The cyclic loading was performed at two hertz. The hydraulic actuator and load cell was subjected to displacement control thus the maximum and minimum displacement values were -1.02" and -0.20", respectively. It was observed that the -900 lbs maximum load began to slowly increase but was manually adjusted back to the required -900 lbs at 978 seconds into the test. This manual adjustment took approximately 58 seconds to complete. Neglecting this adjustment, the load curves are smooth indicating that no anomalies were recorded.

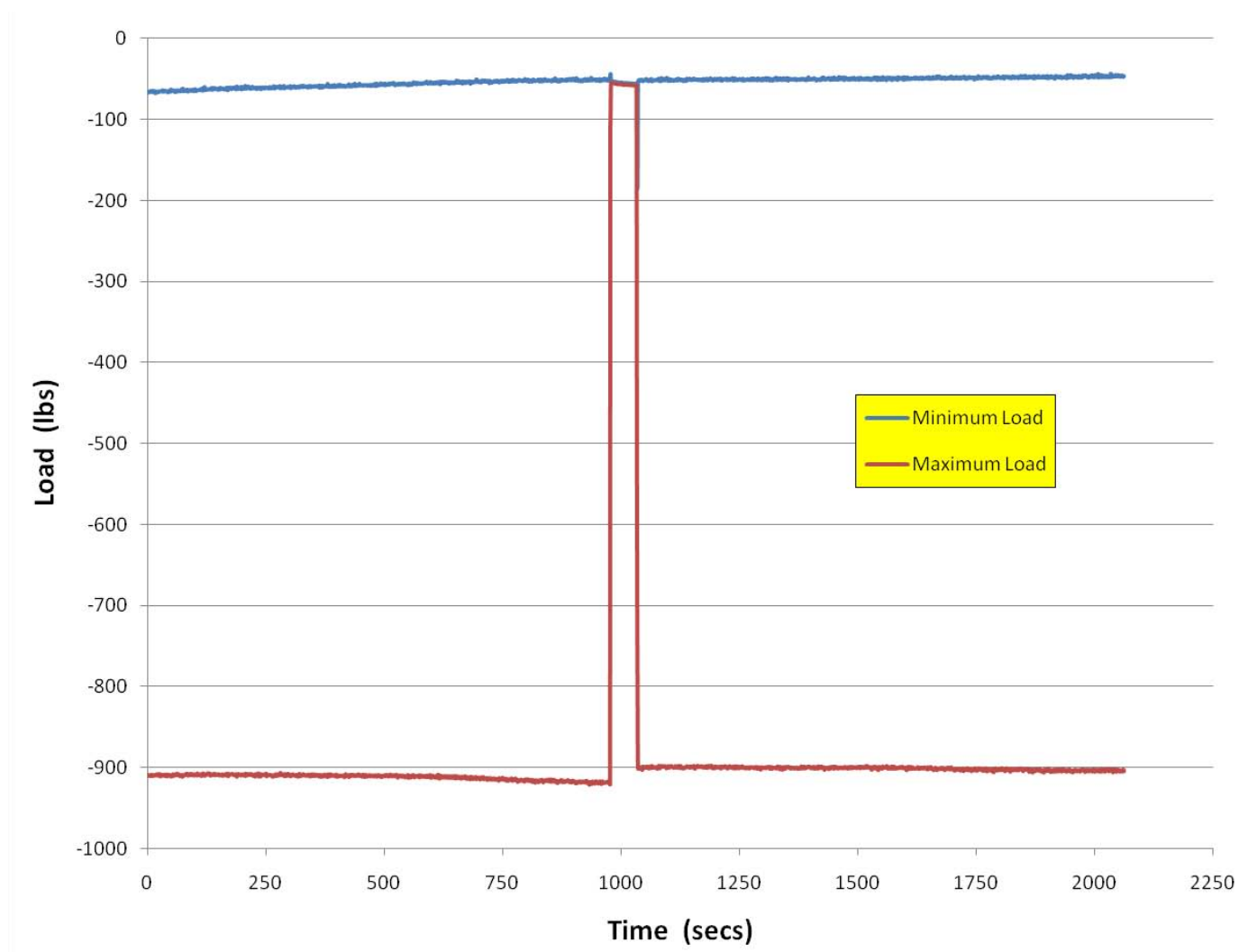

Figure 10. Cyclic Load vs. Time, Case #1b

Cyclic Load Case #2b

The second cyclic .50 caliber machine gun loading spectrum was applied for 420,000 cycles. Load as a function of time for Cyclic Load Case #2b was recorded (Figure 11). The cyclic loading was performed at four hertz. The hydraulic actuator and load cell was subjected to displacement control thus the maximum and minimum displacement values were 0.72" and 0.24", respectively. The load curves are smooth indicating that no anomalies were recorded.

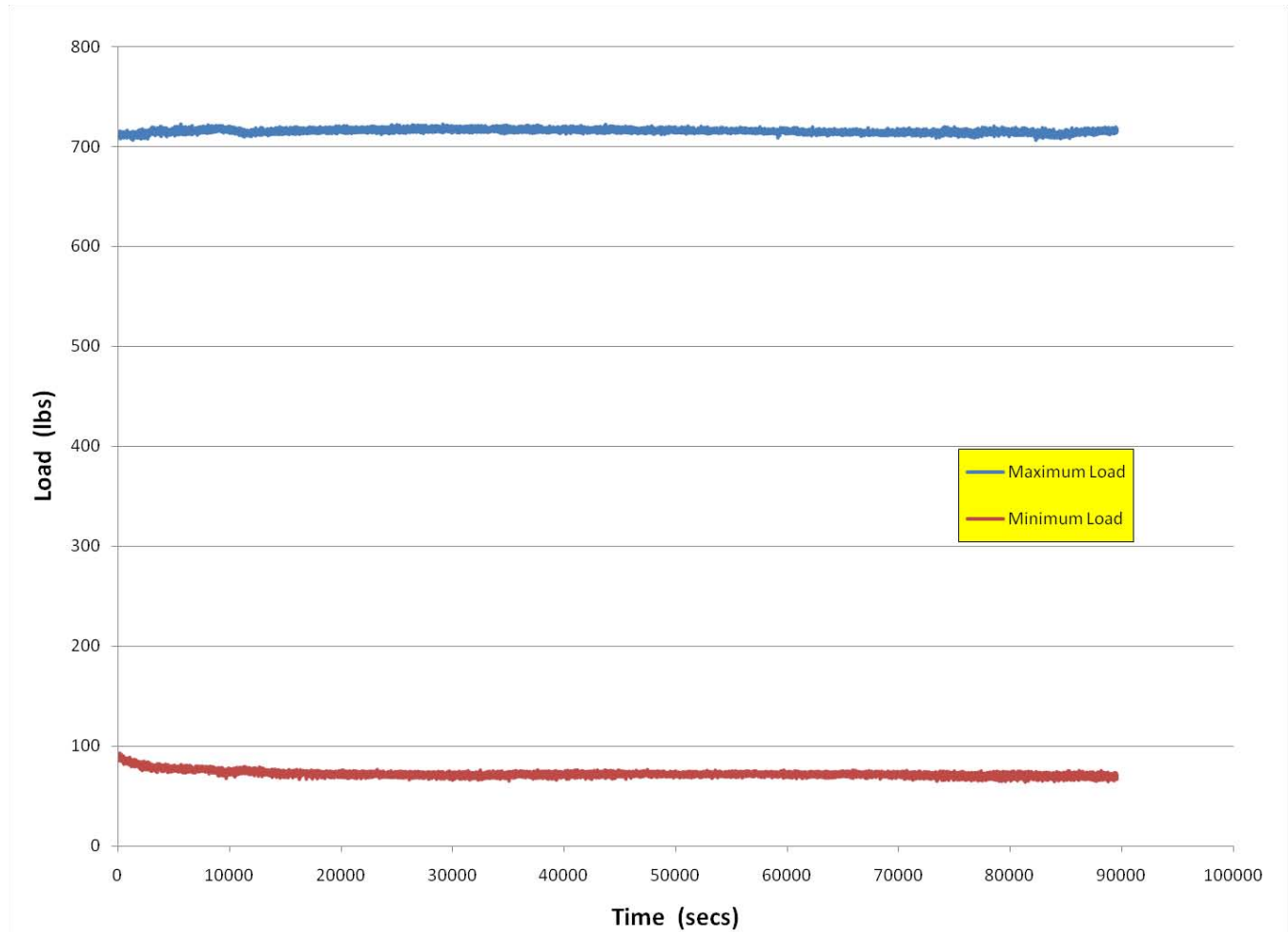

Figure 11. Cyclic Load vs. Time, Case #2b

Cyclic Load Case #3b

The second cyclic Hydra rocket loading spectrum was applied for 42,000 cycles. Load as a function of time for Cyclic Load Case #3b was recorded (Figure 12). The cyclic loading was performed at three hertz. The hydraulic actuator and load cell was subjected to displacement control thus the maximum and minimum displacement values were 0.97" and 0.17", respectively. The load curves are smooth indicating that no anomalies were recorded.

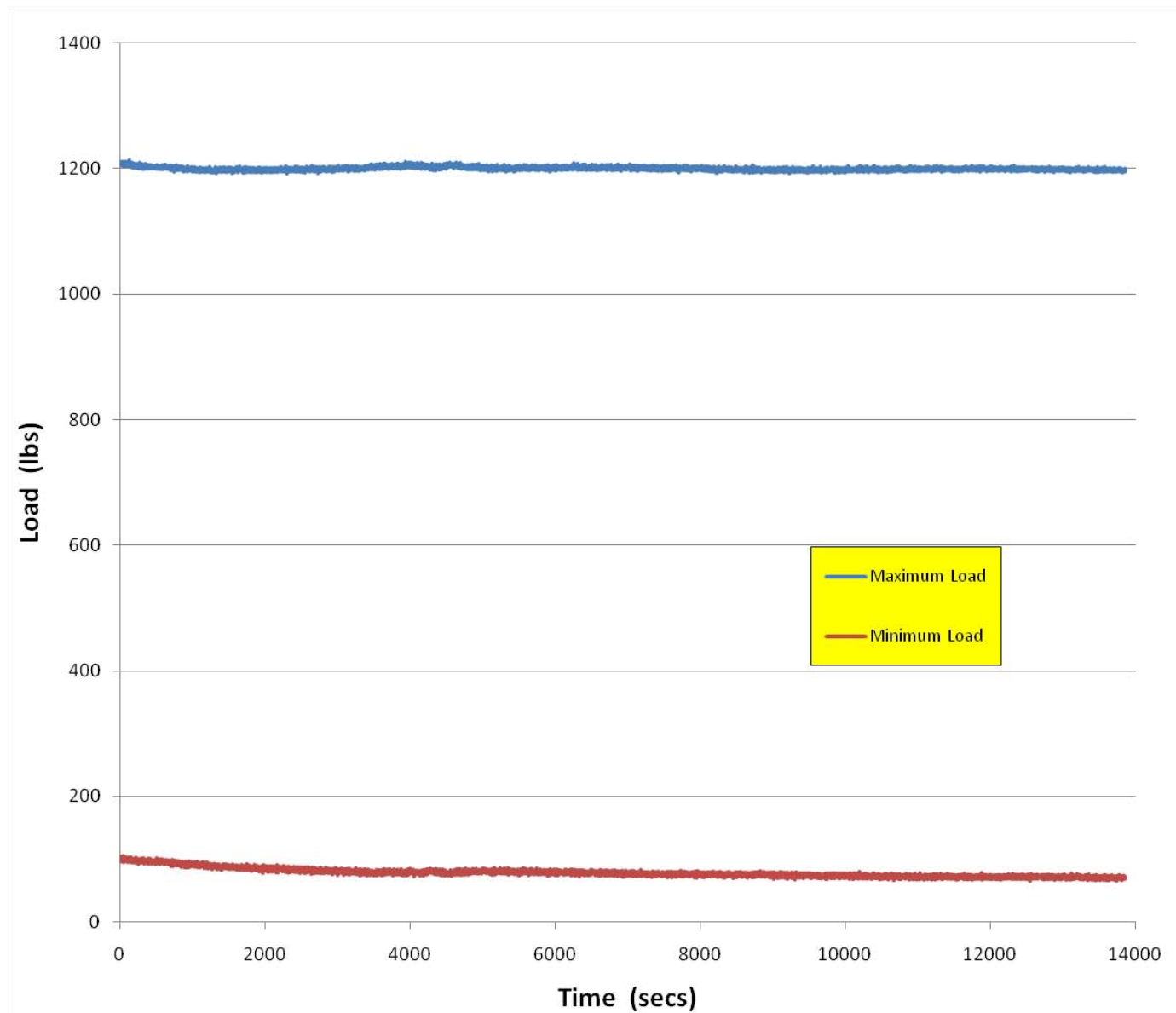

Figure 12. Cyclic Load vs. Time, Case #3b

Proof Load Case #1b

Proof Load Case #1b simulates Hydra rocket loading and was conducted to demonstrate no stiffness or strength reduction occurred in the test article after the completion of the of the second block of cyclic loading. Proof Load Case #1b was conducted in the same manner as Proof Load Case #1a. Load as a function of displacement was recorded for Proof Load Case #1b (Figure 13). The load versus displacement curves for Proof Load Cases #1a and #1b are almost identical. Therefore, it is logical to conclude that no stiffness or strength reduction occurred as a result of the second block of cyclic loading.

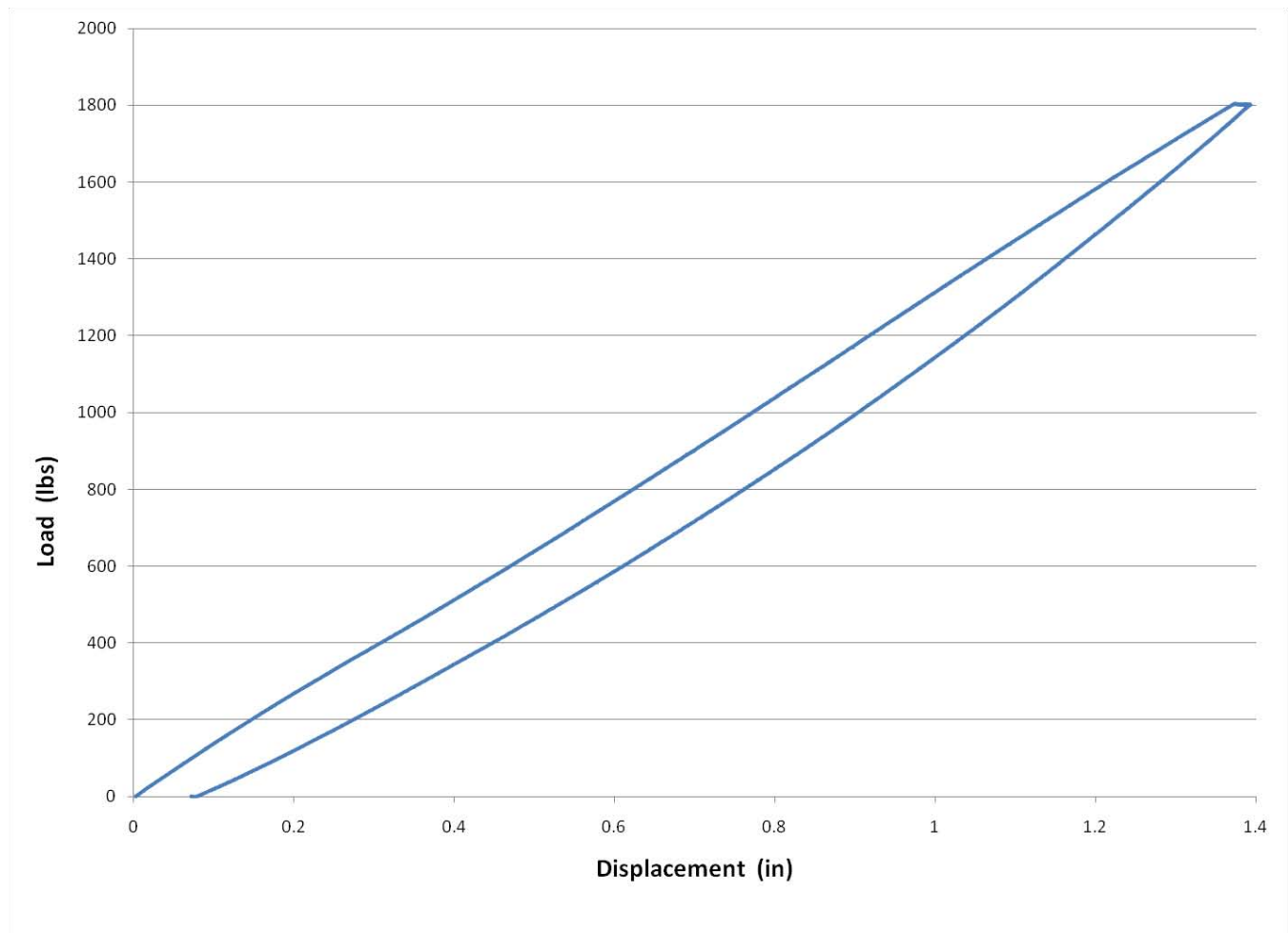

Figure 13. Load vs. Displacement, Proof Load Case #1b

Proof Load Case #2b

Proof Load Case #2b simulates HELLFIRE loading and was conducted to demonstrate no stiffness or strength reduction occurred in the test article after the completion of the of the second block of cyclic loading. Proof Load Case #2b was conducted in the same manner as Proof Load Case #2a. Load as a function of displacement was recorded for Proof Load Case #2b (Figure 14). A slight increase in maximum displacement occurred during Proof Load Case #2b compared to Proof Load Case #2a. The difference in displacement is less than 10% and can be considered negligible. Therefore, it is logical to conclude that no stiffness or strength reduction occurred as a result of the second block of cyclic loading.

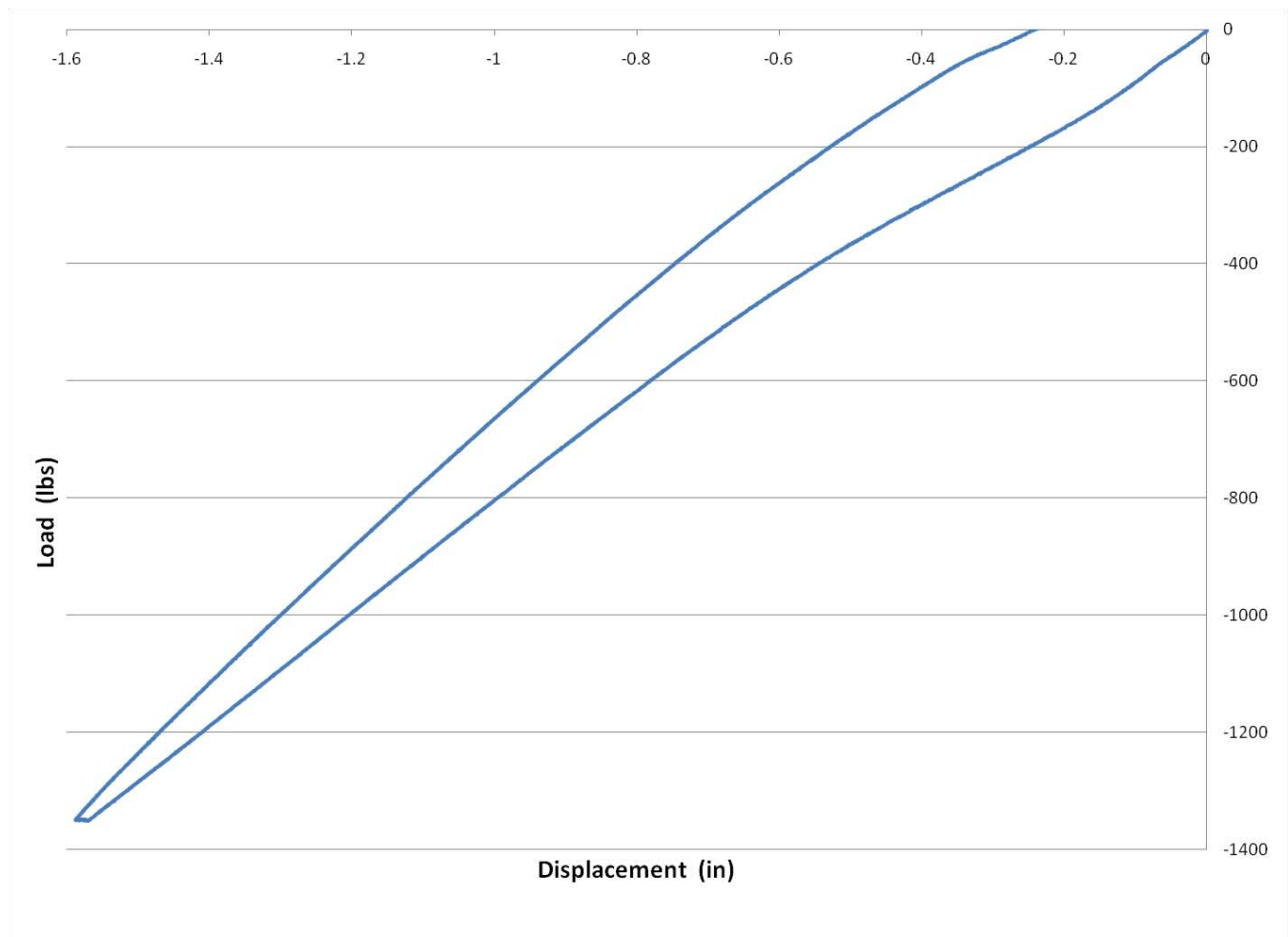

Figure 14. Load vs. Displacement, Proof Load Case #2b



Visual Inspection

The CUWP test article and fixtures were visually inspected after each cyclic load, stiffness check, and proof load. No damage was detected upon inspections. In addition, thorough exterior and interior visual inspections of the CUWP test article were conducted prior to testing (Reference b) and after all testing was completed (Reference c). The visual inspections were performed using a 5x magnification flash light and an illuminated borescope. The results of the inspections of the test article showed that all outer surfaces of the composite tube were intact, the outer surfaces of the fittings were intact, and no working rivets were detected.

Summary and Conclusions

Three load conditions were tested in two blocks of cyclic loading (Table 3). Each block is equivalent to two lifetimes of weapons firing on the OH-58D. The maximum and minimum load ranges in Load Case #1b neglect the variance due to the manual adjustment of the loading. The pass criteria of the fatigue test was dependent on: 1) the ability of the test article to hold the proof loads without structural failure, and 2) the post-test visual inspection would reveal no changes in the structural integrity of the complete test article assembly as compared to the pre-test visual inspection. Based upon the results of the proof load test cases and the pre-test and post-test visual inspections, the CUWP test article successfully met the fatigue equivalent to four lifetimes of weapons firing on the OH-58D.

Table 3. Summary of Cyclic Load Cases

Load Case	Frequency (Hz)	Cycles	Max Load Range (lb)	Min Load Range (lb)	Max Displacement (in)	Min Displacement (in)
#1a	2	4,200	-887.9 -895.1	-83.5 -103.6	-0.96	-0.20
#2a	4	420,000	670.7 716.5	94.2 119.8	0.61	0.18
#3a	3	42,000	1182.5 1212.8	65.5 108.9	1.04	0.22
#1b	2	4,200	-898.3 -921.6	-43.8 -67.7	-1.02	-0.20
#2b	4	420,000	706.0 722.4	63.6 93.1	0.72	0.24
#3b	3	42,000	1192.6 1213.4	64.3 105.1	0.97	0.17

Point of Contact

The point of contact for this test report is Mr. Jay P. Kiser II, Aviation Applied Technology Directorate, RDMR-AAF, Fort Eustis, VA 23604-5577, Phone: (757) 878-7084, E-mail: jay.kiser@us.army.mil

Aviation Applied Technology Directorate
US Army Research, Development and Engineering Command



Composite Universal Weapons Pylon Fatigue Test Plan

Aviation Applied Technology Directorate
US Army AMRDEC
RDMR-AAF
Fort Eustis, VA 23604-5577

10 March 2010 (Base)

Prepared by: Jay P. Kiser II
Jay P. Kiser II

Reviewed by: Timothy S. Davis
Timothy S. Davis

Approved by: Kristopher F. Kuck
Kristopher F. Kuck



Test Objective

Fatigue test a Composite Universal Weapons Pylon (CUWP) with cyclic .50 caliber machine gun, HELLFIRE missile, and Hydra rocket loads to substantiate a 10,000 hour fatigue life.

Approach

Actuators will be positioned in order to simulate a .50 caliber machine gun, HELLFIRE missile, and Hydra rocket loads. The loads will be applied parallel to the aircraft at a point equivalent to the gun, missile, and rocket locations to produce shear and moment loads on the CUWP. Load cases, setup, instrumentation, test procedures, and test article inspections are described in this test plan.

Load Cases and Setup

The CUWP test article/fixture assembly will be mounted with the same aft canted orientation as would be installed on the left side of the aircraft. The incremental load cases listed in Table 1 will be executed. The desire will be to run each load level for the specified number of cycles. The test article, fixture setup, and backstop natural frequencies affect the available load input frequencies and exact values will be determined during the pre-test verification stage.

Table 1. CUWP Test Article Load Cases

Load Case	Weapon	Fatigue Load (lb)	STA, BL, WL (in)	Load Direction	Cycles Planned	Frequency (Hz)
#1a	HELLFIRE Missiles	100 to 900	97.76, -59.65, 21.09	Forward (-X)	4,200	< 5
#2a	.50 Cal Gun	100 to 700	105.04, -58.10, 34.03	Aft (+X)	420,000	< 17.5
#3a	Hydra Rockets	100 to 1200	105.04, -58.10, 34.03	Aft (+X)	42,000	< 5
#1b	HELLFIRE Missiles	100 to 900	97.76, -59.65, 21.09	Forward (-X)	4,200	< 5
#2b	.50 Cal Gun	100 to 700	105.04, -58.10, 34.03	Aft (+X)	420,000	< 17.5
#3b	Hydra Rockets	100 to 1200	105.04, -58.10, 34.03	Aft (+X)	42,000	< 5

The fatigue test plan will involve three different load cases with two different locations for load application as shown in Figure 1. Load Case 1 consists of the HELLFIRE missile thrust location at coordinates of STA 97.76, BL -59.65, WL 21.09. For the purposes of this test, it is assumed that the .50 caliber gun and Hydra rockets share the same load point which will be defined by Load Case 2 and 3 with coordinates of STA 105.04, BL -58.10, WL 34.03.

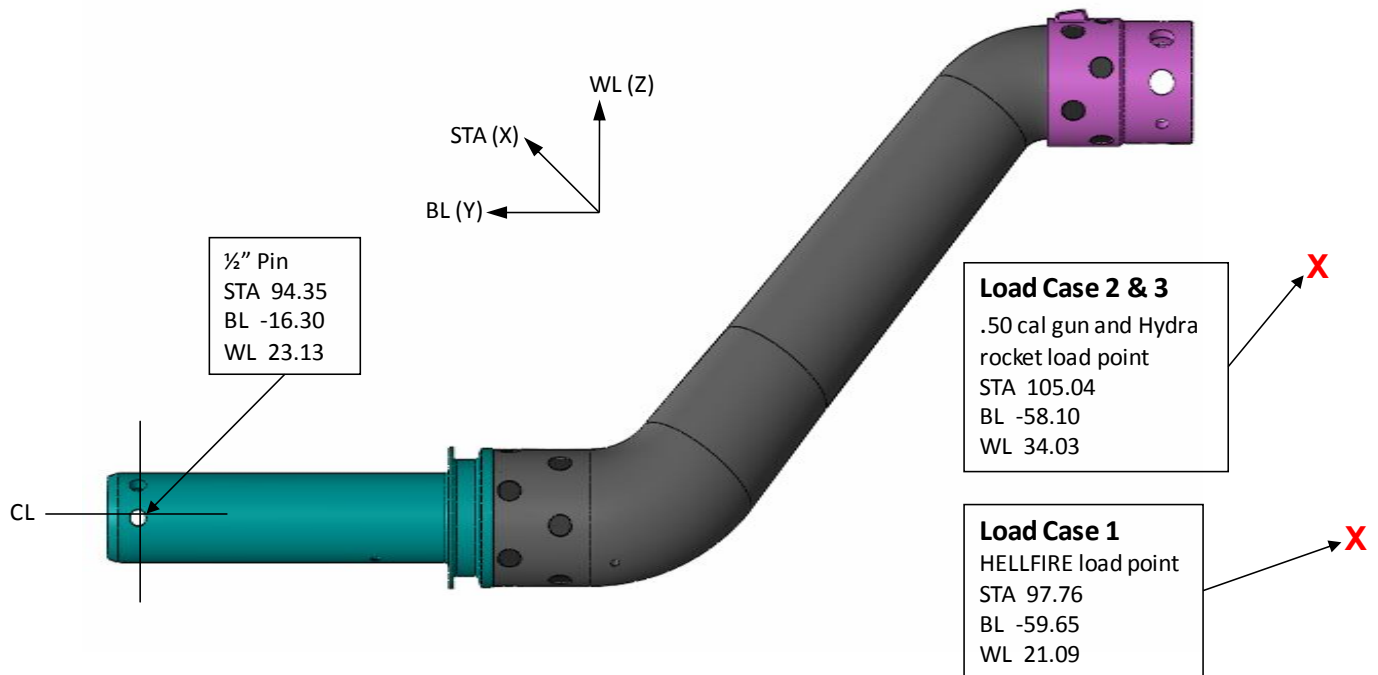

Figure 1. CUWP Test Article Load Points

Stiffness Check

Prior to each load case and at the completion of the final load case, the CUWP test article will be subjected to a stiffness check in order to determine if any variations in stiffness occur during the fatigue load cases. The stiffness check will consist of one stroke measuring applied load versus displacement up to a load limit of 700 lb. Table 2 provides the requirements for the stiffness checks.



Table 2. CUWP Test Article Stiffness Checks

Stiffness Check	Performed	Load (lb)	STA, BL, WL (in)	Load Direction
#1	Prior to Load Case 1a	700	105.04, -58.10, 34.03	Aft (+X)
#2	Prior to Load Case 2a	700	105.04, -58.10, 34.03	Aft (+X)
#3	Prior to Load Case 3a	700	105.04, -58.10, 34.03	Aft (+X)
#4	Prior to Load Case 1b	700	105.04, -58.10, 34.03	Aft (+X)
#5	Prior to Load Case 2b	700	105.04, -58.10, 34.03	Aft (+X)
#6	Prior to Load Case 3b	700	105.04, -58.10, 34.03	Aft (+X)
#7	After Load Case 3b	700	105.04, -58.10, 34.03	Aft (+X)

Proof Loading

Following the cyclic loading, the test article shall be subjected to proof loading. The proof loads will be 1.5 times the fatigue loads as provided in Table 3. The fatigue test pass criteria will be the ability of the CUWP test article to successfully carry the proof loads upon completion of the cyclic fatigue loads.

Table 3. CUWP Test Article Proof Loading

Proof Load	Weapon	Performed	Load (lb)	STA, BL, WL (in)	Load Direction
#1	.50 Cal Gun / Hydra Rocket	After Load Case #3b	1,800	105.04, -58.10, 34.03	Aft (+X)
#2	HELLFIRE Missiles	After Proof Load #1	1,350	97.76, -59.65, 21.09	Forward (-X)

CUWP Test Article

The CUWP test article that will be used in this fatigue test was designed and manufactured by Integrated Composites Inc. The part number of this CUWP Assembly is AR0044001-00 and the bill of materials is listed in Table 4.



Table 4. Bill of Materials for the AR0044001-00 CUWP Assembly

Qty	Material	Part #	Description
1	8552/IM7 Type 35, Class 1, Grade 190	AR0042001-00	COMPOSITE MAIN TUBE
1	Ti 6Al-4V	AR0042002-00	INBOARD FITTING
1	Ti 6Al-4V	AR0042003-00	OUTBOARD FITTING
12	Titanium (Grade 2)	AR0042004-00	5/16" Dimple Washer
12	A286 CRES	MS21140U-1011	HUCK 5/16" 100 DEG RIVET, -11 Grip
10	A286 CRES	MS21140U-1010	HUCK 5/16" 100 DEG RIVET, -10 Grip
10	18-8 Stainless Steel	NAS1149C0432R	5/16" 18-8 SS Washers
1	Stainless	T3585-04C168	4-40 Tangless Heli-coil
1	Stainless	NAS1352C04H3	4-40 Socket head cap screw
AR	Adhesive	EA 9309.3	Hysol Adhesive
AR	Sealant	PR-2200	PRC Electrically Conductive Sealant
AR	Paint	MIL-DTL-53039	CARC Paint Aircraft Green
AR	Primer	MIL-PRF-23377	Non-Chromate Primer

The CUWP test article is not a new part which has already been subjected to service. From the period of July 2009 thru December 2009, the CUWP test article flew over 50 flight hours and includes the following live fire tests:

- a) 1000 rounds of .50 caliber ball ammunition from the M3P machine gun
- b) Four (4) HELLFIRE shots
- c) Eight (8) 2.75 Hydra rocket shots
- d) Six (6) safe separation shots
- e) Eleven (11) guided round shots of other missile systems

Facility

The fatigue test will utilize AATD's 40' x 20' x 20' "backstop" facility, hydraulic actuators providing load and stroke capacities required for the defined load cases, and load cells with measurement ranges sufficient for the maximum forces being applied.

The facility's temperature and humidity level will be measured and recorded daily in Table 5. The collection of temperature and humidity data is for informational purposes only as this test will be conducted at ambient conditions.



Table 5. Temperature and Humidity

Date	Time	Temperature (°F)	% Humidity

Instrumentation

1. MTS 5.5 kip Hydraulic Actuator
 - a. Capacity: 5500 lbs
 - b. Stroke: 10 inches
 - c. S/N 10280365
 - d. Last calibration: May 2009

2. Lebow 5 kip Load Cell
 - a. Capacity: 5000 lbs
 - b. S/N 6009
 - c. Last calibration: May 2009

3. Pacific Instruments Data Acquisition System
 - a. M/N PI6000
 - b. S/N 0748104
 - c. Last calibration: September 2009

4. Pacific Instruments Signal Conditioners
 - a. M/N 9355Q
 - b. Last calibration: September 2009

Applied displacement, applied force, and strain of the CUWP test article will be measured and recorded using the laboratory data acquisition system. The hydraulic actuator and load cell will be subjected to displacement control as opposed to load control to avoid unnecessary damage to the article in the event there is a premature failure in the test fixture and/or test article. Also, the instrumentation will be programmed to shutoff if the maximum or minimum load varies more than 5% for each prescribed load case. Data acquisition will acquire all values at 5000 Hz and the maximum, minimum, and average values will be recorded at 1 Hz. The following channels will be recorded:



1. Applied Force
2. Applied Displacement
3. CUWP Strains

Prior to conducting the fatigue test, the load cells and actuator will be subjected to a load and displacement check. This will be accomplished by applying a known load and verifying the same value is being recorded. The displacement of the actuator will be checked with a known displacement and verifying the same value is being recorded.

Test Fixture and Base Fixtures

The inboard end of the CUWP will be installed as a slip fit in a rigid support housing as shown in Figure 2. The part will be constrained by a close tolerance $\frac{1}{2}$ " pin installed at BL -16.30. This will constrain translational and rotational movement along the Y axis. The second constraint will be at the collet so that the collet is fixed in the area between of BL -18.0 and BL -21.5. BL -18.0 is where the collet stops providing support to the structure and BL -21.5 is where the aircraft terminates support. This will constrain translational and rotational movement along the X and Z axes.

The CUWP article/test fixture assembly will be mounted on the backstop with the same orientation as installed on the aircraft. Load application will be accomplished by a hydraulic actuator and load cell which will also be mounted to the backstop but independent of the test fixture. This independence is required to ensure that the reactive loads between the test article/fixture and the load application support do not cause fixture distortion during the actual test. The weight of the test fixture is approximately 71.4 lb. The force of the actuator acting down at the test fixture connection is approximately 52 lb.

Loading

The loads will be applied to a steel test fixture that mounts in the same manner as the weapons assembly. The load cell will be attached to the 1.5" thick 7075-T6 AL ALY arm using an eyebolt. This loading location and test configuration is shown in Figure 2. The test setup geometry will be configured for loading a left side mounted, aft canted CUWP. Depending on the load case being tested, the actual direction of the applied load vector (load cell orientation) is as follows:

Load Case 1: HELLFIRE missile, 100 lb – 900 lb loading in the -X (forward) direction.

Load Case 2: .50 caliber gun, 100 lb – 700 lb loading in the +X (aft) direction

Load Case 3: Hydra rockets, 100 lb – 1200 lb loading in the +X (aft) direction

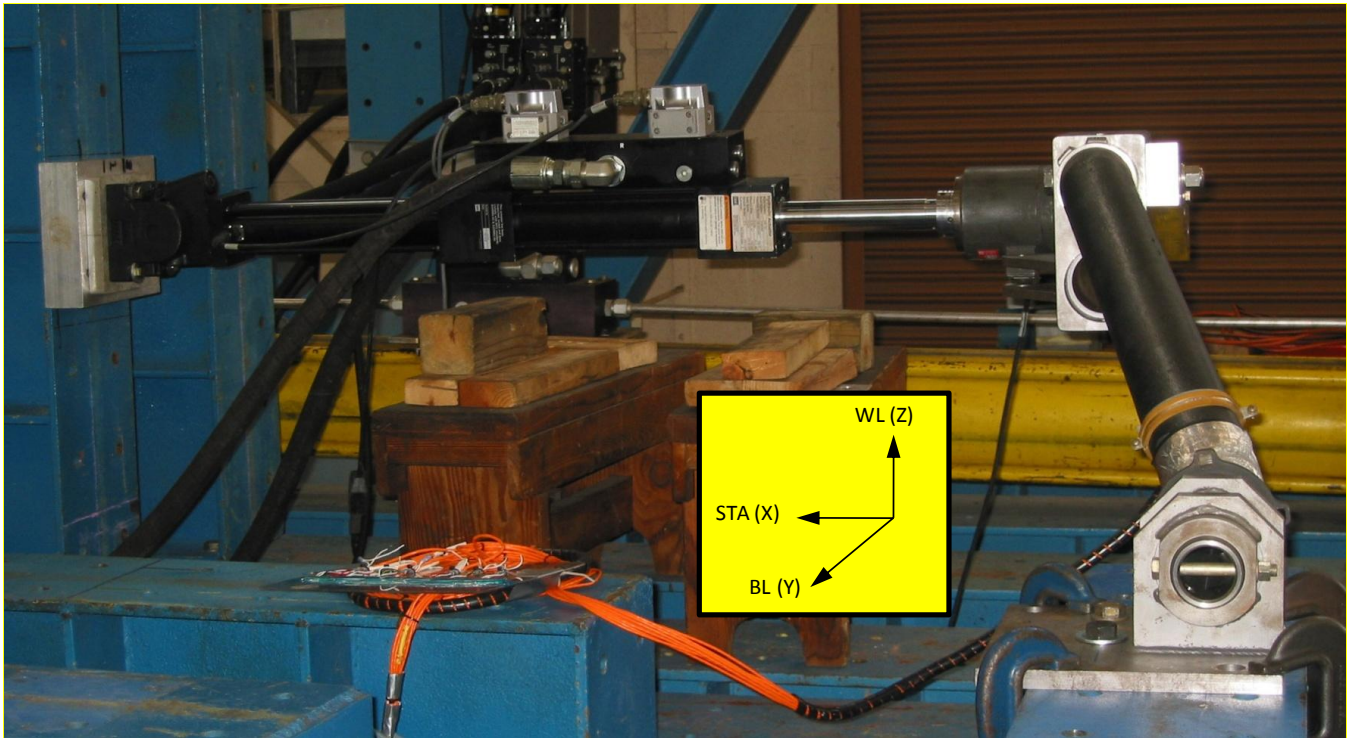

Figure 2. CUWP Test Article and Fixture Setup

Visual Inspection

The CUWP test article and fixtures will be visually inspected at specified intervals as outlined below. The CUWP test article will be inspected to look for cracks or delaminations of the composite tube, cracking or loosening of the Huck bolts, cracking or elongation of the inboard and outboard titanium fittings, and cracking or elongation of the test fixtures. The visual inspection shall be conducted without removing the Huck bolts. Any defects found shall be documented.

- 1) Prior to Load Case #1a
- 2) After Load Case #1a is complete
- 3) After Load Case #2a is complete
- 4) After Load Case #3a is complete
- 5) After Load Case #1b is complete
- 6) After Load Case #2b is complete
- 7) After Load Case #3b is complete



- 8) After Proof Load Case #1 is complete
- 9) After Proof Load Case #2 is complete

Point of Contact

The point of contact for this test plan is Mr. Jay P. Kiser II, Aviation Applied Technology Directorate, RDMR-AAF, Fort Eustis, VA 23604-5577, Phone: (757) 878-7084, E-mail: jay.kiser@us.army.mil

Aviation Applied Technology Directorate
US Army Research, Development and Engineering Command



Composite Universal Weapons Pylon Fatigue Test Plan

Aviation Applied Technology Directorate
US Army AMRDEC
RDMR-AAF
Fort Eustis, VA 23604-5577

22 March 2010 (Revision 1)

Prepared by: Jay P. Kiser II
Jay P. Kiser II

Reviewed by: Timothy S. Davis
Timothy S. Davis

Approved by: Kristopher F. Kuck
Kristopher F. Kuck



Revision History

Revision	Change	Page
1	Added paragraph "Energy Impacts"	4
1	Added Figure 2	5
1	Added Stiffness Check #4 in Table 2	6
1	Added Proof Loads #1b and #2b in Table 3	6



Test Objective

Fatigue test a Composite Universal Weapons Pylon (CUWP) with cyclic .50 caliber machine gun, HELLFIRE missile, and Hydra rocket loads to substantiate a 10,000 hour fatigue life.

Approach

Actuators will be positioned in order to simulate a .50 caliber machine gun, HELLFIRE missile, and Hydra rocket loads. The loads will be applied parallel to the aircraft at a point equivalent to the gun, missile, and rocket locations to produce shear and moment loads on the CUWP. Load cases, setup, instrumentation, test procedures, and test article inspections are described in this test plan.

Load Cases and Setup

The CUWP test article/fixture assembly will be mounted with the same aft canted orientation as would be installed on the left side of the aircraft. The incremental load cases listed in Table 1 will be executed. The desire will be to run each load level for the specified number of cycles. The test article, fixture setup, and backstop natural frequencies affect the available load input frequencies and exact values will be determined during the pre-test verification stage.

Table 1. CUWP Test Article Load Cases

Load Case	Weapon	Fatigue Load (lb)	STA, BL, WL (in)	Load Direction	Cycles Planned	Frequency (Hz)
#1a	HELLFIRE Missiles	100 to 900	97.76, -59.65, 21.09	Forward (-X)	4,200	< 5
#2a	.50 Cal Gun	100 to 700	105.04, -58.10, 34.03	Aft (+X)	420,000	< 17.5
#3a	Hydra Rockets	100 to 1200	105.04, -58.10, 34.03	Aft (+X)	42,000	< 5
#1b	HELLFIRE Missiles	100 to 900	97.76, -59.65, 21.09	Forward (-X)	4,200	< 5
#2b	.50 Cal Gun	100 to 700	105.04, -58.10, 34.03	Aft (+X)	420,000	< 17.5
#3b	Hydra Rockets	100 to 1200	105.04, -58.10, 34.03	Aft (+X)	42,000	< 5

The fatigue test plan will involve three different load cases with two different locations for load application as shown in Figure 1. Load Case 1 consists of the HELLFIRE missile thrust location at coordinates of STA 97.76, BL -59.65, WL 21.09. For the purposes of this test, it is assumed that the .50 caliber gun and Hydra rockets share the same load point which will be defined by Load Case 2 and 3 with coordinates of STA 105.04, BL -58.10, WL 34.03.

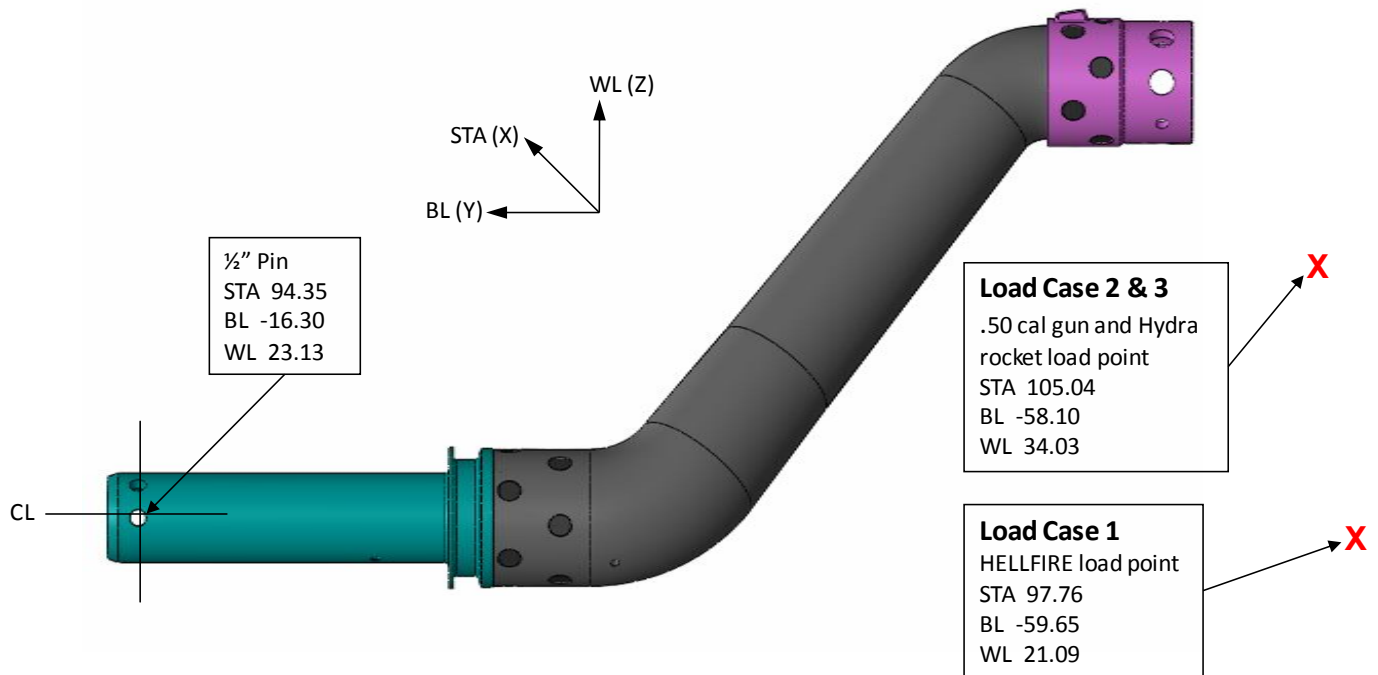

Figure 1. CUWP Test Article Load Points

Energy Impacts

After Load Case 3a is complete, the test article shall be subjected to energy impacts at locations shown in Figure 2. The minimum energy impact at these locations shall be 5 ft-lbs using a 0.5" diameter hemisphere impact tip. The locations indicated in Figure 2 are only approximate since there is a tolerance required for the placement of the impactor gun. After the impacts are performed, more precise coordinates will be stated in the final report.

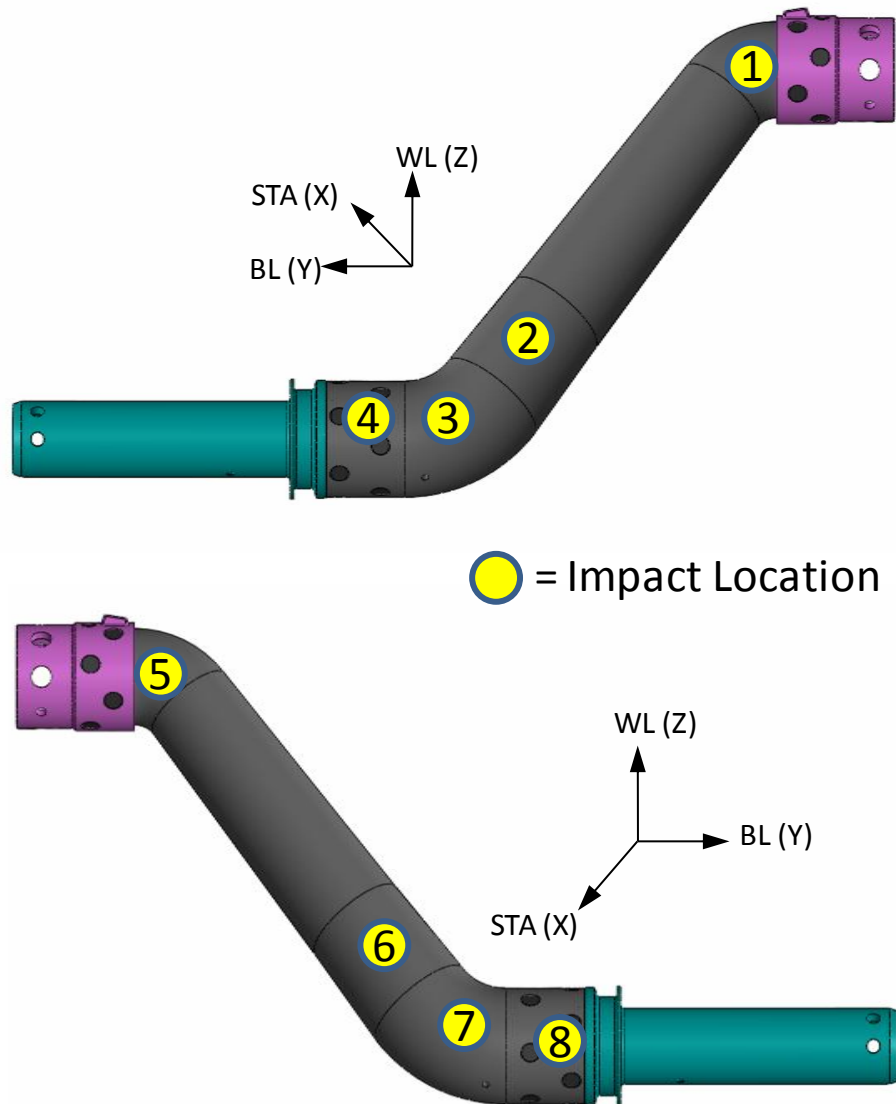

Figure 2. CUWP Test Article Impact Locations

Stiffness Check

Prior to each load case and at the completion of the final load case, the CUWP test article will be subjected to a stiffness check in order to determine if any variations in stiffness occur during the fatigue load cases. The stiffness check will consist of one stroke measuring applied load versus displacement up to a load limit of 700 lb. Table 2 provides the requirements for the stiffness checks.



Table 2. CUWP Test Article Stiffness Checks

Stiffness Check	Performed	Load (lb)	STA, BL, WL (in)	Load Direction
#1	Prior to Load Case 1a	700	105.04, -58.10, 34.03	Aft (+X)
#2	Prior to Load Case 2a	700	105.04, -58.10, 34.03	Aft (+X)
#3	Prior to Load Case 3a	700	105.04, -58.10, 34.03	Aft (+X)
#4	After Load Case 3a	700	105.04, -58.10, 34.03	Aft (+X)
#5	Prior to Load Case 1b	700	105.04, -58.10, 34.03	Aft (+X)
#6	Prior to Load Case 2b	700	105.04, -58.10, 34.03	Aft (+X)
#7	Prior to Load Case 3b	700	105.04, -58.10, 34.03	Aft (+X)
#8	After Load Case 3b	700	105.04, -58.10, 34.03	Aft (+X)

Proof Loading

Following the cyclic loading, the test article shall be subjected to proof loading. The proof loads will be 1.5 times the fatigue loads as provided in Table 3. The fatigue test pass criteria will be the ability of the CUWP test article to successfully carry the proof loads upon completion of the cyclic fatigue loads.

Table 3. CUWP Test Article Proof Loading

Proof Load	Weapon	Performed	Load (lb)	STA, BL, WL (in)	Load Direction
#1a	.50 Cal Gun / Hydra Rocket	After Load Case #3a	1,800	105.04, -58.10, 34.03	Aft (+X)
#2a	HELLFIRE Missiles	After Proof Load #1a	1,350	97.76, -59.65, 21.09	Forward (-X)
#1b	.50 Cal Gun / Hydra Rocket	After Stiffness Check #7	1,800	105.04, -58.10, 34.03	Aft (+X)
#2b	HELLFIRE Missiles	After Proof Load #1b	1,350	97.76, -59.65, 21.09	Forward (-X)



CUWP Test Article

The CUWP test article that will be used in this fatigue test was designed and manufactured by Integrated Composites Inc. The part number of this CUWP Assembly is AR0044001-00 and the bill of materials is listed in Table 4.

Table 4. Bill of Materials for the AR0044001-00 CUWP Assembly

Qty	Material	Part #	Description
1	8552/IM7 Type 35, Class 1, Grade 190	AR0042001-00	COMPOSITE MAIN TUBE
1	Ti 6Al-4V	AR0042002-00	INBOARD FITTING
1	Ti 6Al-4V	AR0042003-00	OUTBOARD FITTING
12	Titanium (Grade 2)	AR0042004-00	5/16" Dimple Washer
12	A286 CRES	MS21140U-1011	HUCK 5/16" 100 DEG RIVET, -11 Grip
10	A286 CRES	MS21140U-1010	HUCK 5/16" 100 DEG RIVET, -10 Grip
10	18-8 Stainless Steel	NAS1149C0432R	5/16" 18-8 SS Washers
1	Stainless	T3585-04C168	4-40 Tangless Heli-coil
1	Stainless	NAS1352C04H3	4-40 Socket head cap screw
AR	Adhesive	EA 9309.3	Hysol Adhesive
AR	Sealant	PR-2200	PRC Electrically Conductive Sealant
AR	Paint	MIL-DTL-53039	CARC Paint Aircraft Green
AR	Primer	MIL-PRF-23377	Non-Chromate Primer

The CUWP test article is not a new part which has already been subjected to service. From the period of July 2009 thru December 2009, the CUWP test article flew over 50 flight hours and includes the following live fire tests:

- a) 1000 rounds of .50 caliber ball ammunition from the M3P machine gun
- b) Four (4) HELLFIRE shots
- c) Eight (8) 2.75 Hydra rocket shots
- d) Six (6) safe separation shots
- e) Eleven (11) guided round shots of other missile systems

Facility

The fatigue test will utilize AATD's 40' x 20' x 20' "backstop" facility, hydraulic actuators providing load and stroke capacities required for the defined load cases, and load cells with measurement ranges sufficient for the maximum forces being applied.



The facility's temperature and humidity level will be measured and recorded daily in Table 5. The collection of temperature and humidity data is for informational purposes only as this test will be conducted at ambient conditions.

Table 5. Temperature and Humidity

Date	Time	Temperature (°F)	% Humidity

Instrumentation

1. MTS 5.5 kip Hydraulic Actuator
 - a. Capacity: 5500 lbs
 - b. Stroke: 10 inches
 - c. S/N 10280365
 - d. Last calibration: May 2009

2. Lebow 5 kip Load Cell
 - a. Capacity: 5000 lbs
 - b. S/N 6009
 - c. Last calibration: May 2009

3. Pacific Instruments Data Acquisition System
 - a. M/N PI6000
 - b. S/N 0748104
 - c. Last calibration: September 2009

4. Pacific Instruments Signal Conditioners
 - a. M/N 9355Q
 - b. Last calibration: September 2009

Applied displacement, applied force, and strain of the CUWP test article will be measured and recorded using the laboratory data acquisition system. The hydraulic actuator and load cell will be subjected to displacement control as opposed to load control to avoid unnecessary damage to the article in the event there is a premature failure in the test fixture and/or test article. Also, the instrumentation will be



programmed to shutoff if the maximum or minimum load varies more than 5% for each prescribed load case. Data acquisition will acquire all values at 5000 Hz and the maximum, minimum, and average values will be recorded at 1 Hz. The following channels will be recorded:

1. Applied Force
2. Applied Displacement
3. CUWP Strains

Prior to conducting the fatigue test, the load cells and actuator will be subjected to a load and displacement check. This will be accomplished by applying a known load and verifying the same value is being recorded. The displacement of the actuator will be checked with a known displacement and verifying the same value is being recorded.

Test Fixture and Base Fixtures

The inboard end of the CUWP will be installed as a slip fit in a rigid support housing as shown in Figure 3. The part will be constrained by a close tolerance ½” pin installed at BL -16.30. This will constrain translational and rotational movement along the Y axis. The second constraint will be at the collet so that the collet is fixed in the area between of BL -18.0 and BL -21.5. BL -18.0 is where the collet stops providing support to the structure and BL -21.5 is where the aircraft terminates support. This will constrain translational and rotational movement along the X and Z axes.

The CUWP article/test fixture assembly will be mounted on the backstop with the same orientation as installed on the aircraft. Load application will be accomplished by a hydraulic actuator and load cell which will also be mounted to the backstop but independent of the test fixture. This independence is required to ensure that the reactive loads between the test article/fixture and the load application support do not cause fixture distortion during the actual test. The weight of the test fixture is approximately 71.4 lb. The force of the actuator acting down at the test fixture connection is approximately 52 lb.

Loading

The loads will be applied to a steel test fixture that mounts in the same manner as the weapons assembly. The load cell will be attached to the 1.5” thick 7075-T6 AL ALY arm using an eyebolt. This loading location and test configuration is shown in Figure 3. The test setup geometry will be configured for loading a left side mounted, aft canted CUWP. Depending on the load case being tested, the actual direction of the applied load vector (load cell orientation) is as follows:

Load Case 1: HELLFIRE missile, 100 lb – 900 lb loading in the -X (forward) direction.

Load Case 2: .50 caliber gun, 100 lb – 700 lb loading in the +X (aft) direction

Load Case 3: Hydra rockets, 100 lb – 1200 lb loading in the +X (aft) direction

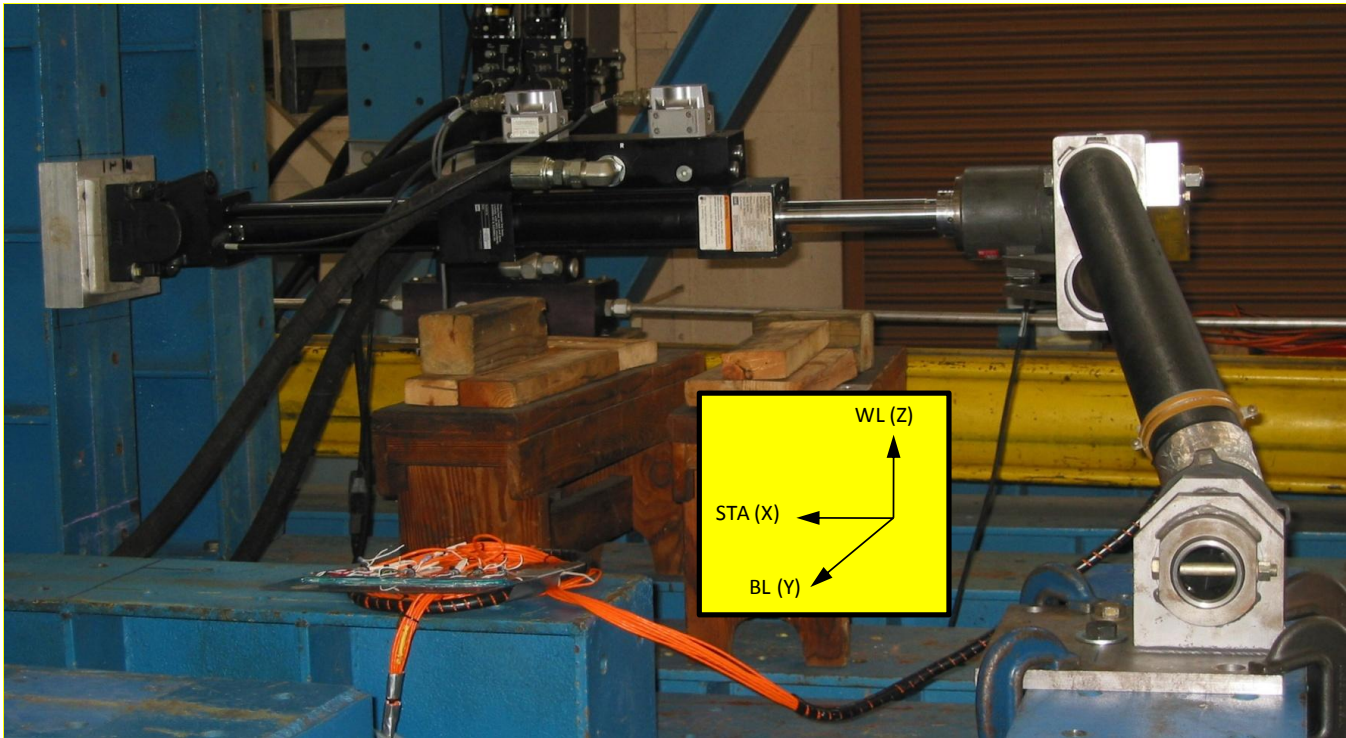

Figure 3. CUWP Test Article and Fixture Setup

Visual Inspection

The CUWP test article and fixtures will be visually inspected at specified intervals as outlined below. The CUWP test article will be inspected to look for cracks or delaminations of the composite tube, cracking or loosening of the Huck bolts, cracking or elongation of the inboard and outboard titanium fittings, and cracking or elongation of the test fixtures. The visual inspection shall be conducted without removing the Huck bolts. Any defects found shall be documented.

- 1) Prior to Load Case #1a
- 2) After Load Case #1a is complete
- 3) After Load Case #2a is complete
- 4) After Load Case #3a is complete
- 5) After Proof Load #1a is complete
- 6) After Proof Load #2a is complete
- 7) After Load Case #1b is complete



- 8) After Load Case #2b is complete
- 9) After Load Case #3b is complete
- 10) After Proof Load Case #1b is complete
- 11) After Proof Load Case #2b is complete

Point of Contact

The point of contact for this test plan is Mr. Jay P. Kiser II, Aviation Applied Technology Directorate, RDMR-AAF, Fort Eustis, VA 23604-5577, Phone: (757) 878-7084, E-mail: jay.kiser@us.army.mil