

**AN INVESTIGATION
OF FRAGMENT STOPPING BARRICADES**

BY

**FRANK McCLESKEY (KILKEARY, SCOTT, AND ASSOC.)
LEE WILSON (ADVANCED TECHNOLOGY, INC.)
ROSE BAKER (NAVAL SURFACE WARFARE CENTER)**

FOR INFORMATION CONTACT:

**FRANK McCLESKEY
RT. 3 BOX 105
KING GEORGE, VA. 22485**

703-775-7210

**24th DOD EXPLOSIVES SAFETY SEMINAR
28 - 30 AUGUST 1990**

Report Documentation Page

Form Approved
OMB No. 0704-0188

Public reporting burden for the collection of information is estimated to average 1 hour per response, including the time for reviewing instructions, searching existing data sources, gathering and maintaining the data needed, and completing and reviewing the collection of information. Send comments regarding this burden estimate or any other aspect of this collection of information, including suggestions for reducing this burden, to Washington Headquarters Services, Directorate for Information Operations and Reports, 1215 Jefferson Davis Highway, Suite 1204, Arlington VA 22202-4302. Respondents should be aware that notwithstanding any other provision of law, no person shall be subject to a penalty for failing to comply with a collection of information if it does not display a currently valid OMB control number.

1. REPORT DATE AUG 1990		2. REPORT TYPE		3. DATES COVERED 00-00-1990 to 00-00-1990	
4. TITLE AND SUBTITLE An Investigation of Fragment Stopping Barricades				5a. CONTRACT NUMBER	
				5b. GRANT NUMBER	
				5c. PROGRAM ELEMENT NUMBER	
6. AUTHOR(S)				5d. PROJECT NUMBER	
				5e. TASK NUMBER	
				5f. WORK UNIT NUMBER	
7. PERFORMING ORGANIZATION NAME(S) AND ADDRESS(ES) Kilkeary, Scott, and Associates, 2301 S. Jefferson Davis hwy Suite 1328, Arlington, VA, 22202				8. PERFORMING ORGANIZATION REPORT NUMBER	
9. SPONSORING/MONITORING AGENCY NAME(S) AND ADDRESS(ES)				10. SPONSOR/MONITOR'S ACRONYM(S)	
				11. SPONSOR/MONITOR'S REPORT NUMBER(S)	
12. DISTRIBUTION/AVAILABILITY STATEMENT Approved for public release; distribution unlimited					
13. SUPPLEMENTARY NOTES See also ADA235006, Volume 2. Minutes of the Explosives Safety Seminar (24th) Held in St. Louis, MO on 28-30 August 1990.					
14. ABSTRACT see report					
15. SUBJECT TERMS					
16. SECURITY CLASSIFICATION OF:			17. LIMITATION OF ABSTRACT Same as Report (SAR)	18. NUMBER OF PAGES 38	19a. NAME OF RESPONSIBLE PERSON
a. REPORT unclassified	b. ABSTRACT unclassified	c. THIS PAGE unclassified			

ABSTRACT

This paper describes a two-part investigation of the reduction in fragment hazards afforded by barricades. Also included is a description of the FRAGHAZ Computer Program used in the investigation. Part I is a general investigation of barricades to test the usefulness of the FRAGHAZ Program and to gain initial in-sight on barricades. Part II covers a specific investigation of the fragment hazard reduction capability of a natural hillside barricade in Taegu, Korea. The results of the investigation indicate that the configuration and positioning of the ammo stacks relative to the barricade are prime considerations in reducing fragmentation hazards.

PREFACE

This paper will be published as a Naval Surface Warfare Center report in the future. The tables to be published in the report have not been included in this paper. However, the more important aspects of the tables are included in the figures contained in this paper. References to the tables have been retained to indicate the scope of the investigation.

INTRODUCTION

This report is divided into two parts. Part I contains a general study of barricades; Part II involves a specific investigation of the barricade effects of hilly terrain in Taegu, Korea.

Barricades have been in use for many years in areas where explosive ordnance is stored. Barricades provide a means for stopping fragments produced by inadvertently detonated ammunition stacks. They may be artificial (man made) or natural obstacles such as hills. This report covers the study of both an artificial and a natural barricade.

All of the numerical results contained in this report were produced by the FRAGHAZ Computer Program.¹ In order to provide the reader with a basis for judging the validity of the numerical data contained herein, the general characteristics and capabilities of the FRAGHAZ Computer Program, together with the variables taken into account, are discussed in the following paragraphs.

FRAGHAZ COMPUTER PROGRAM DESCRIPTION

PURPOSE

The FRAGHAZ Computer Program was developed by the Naval Surface Warfare Center for the Department of Defense Explosives Safety Board (DDESB) to provide a method for predicting the fragment hazards produced by the inadvertent detonation of munitions. The computer program is designed such that it can be easily modified to handle a variety of specific problems like the barricade studies contained in this report.

HAZARD VOLUME

A relatively simple mathematical model is used in the calculation and accumulation of fragment hazard statistics. This hazard volume model is shaped like a narrow piece of pie with the sharp edge fixed to the face of the fragment producing ammunition stack. Down-range is divided into 100 ft sectors such that hazard statistics can be accumulated in 100 ft range increments. The height of the hazard volume is equal to the height of the target, the target in this report being a standing man. The standing man is represented as a three dimensional rectangular parallelepiped randomly located in the hazard volume. Since the hazard volume is shaped like a piece of pie, it diverges as range increases at an angle usually taken as 10 degrees. This 10 deg angle is commensurate with the 10 deg sectors used with actual fragment pickup in full-scale tests of ammunition stacks. This fragment pickup data will be discussed later under FRAGHAZ COMPUTER PROGRAM VALIDATION.

STACK FRAGMENTATION CHARACTERISTICS

The FRAGHAZ Computer Program uses actual fragmentation data from small-scale arena tests which can be scaled up to represent large ammunition stacks. The small-scale tests may consist of one or more pallets of a specific munition. When the individual munitions of a pallet are detonated simultaneously, or nearly so, jets are produced between adjacent munitions. For the FRAGHAZ program these jets are called interaction areas. These interaction areas contain the high

density and high velocity fragmentation which is used for safety purposes to calculate down-range fragmentation hazards. The fragment characteristics necessary to calculate individual trajectories for each fragment recovered in specified polar and azimuthal angle limits are obtained from the small-scale arena tests. For a pallet of Mk 82 bombs there are 260 fragments greater than 300 grains that define the fragmentation characteristics of a single interaction area. Fragments that weigh less than 300 grains do not go to far-field ranges and, even at the short ranges, they seldom possess the kinetic energy at impact to meet the threshold hazard kinetic energy criterion of the DDESB (58 ft-lbs).

FRAGMENT TRAJECTORIES

For each fragment recovered in the small-scale arena test, a complete trajectory is calculated using a fourth order Runge-Kutta procedure. As such, the velocity, displacement and trajectory angle in three dimensions can be calculated at any point along the trajectory. In practice we are mostly concerned with the portion(s) of the trajectory that lie within the Hazard Volume. It is only then that the fragment may impact the target. Since we know the complete dynamics of the fragment we can calculate hazard statistics such as hazard density and hazard probability of hit.

There are two types of trajectories considered: normal and ricochet. The normal trajectories have only one ground impact while the ricochet trajectories have two or more ground impacts. The ricochet equations are based on tests conducted by the Ballistic Research Laboratories in the late 1960s.²

Wind can be included in the trajectory calculations. For a tailwind, the added range due to wind is approximately equal to the time of flight times the wind speed. Since time of flight varies up to about 30 seconds, a tailwind of 60 ft / sec (41 MPH) can extend the range by about 1800 ft.

The fact that a separate and complete trajectory is calculated for each fragment permits the FRAGHAZ Computer Program to be used for a large variety of specific problems like the barricade studies contained herein. The program has also been used to determine hazards to vehicles on public traffic routes and hazards to ammunition stacks from fragments.

MONTE CARLO PROCEDURE

A Monte Carlo procedure is any mathematical technique which uses random numbers to simulate the uncertainty associated with one or more random variables affecting the outcome of the calculations. In FRAGHAZ there are seven random variables affecting the hazard calculations:

- Initial fragment elevation angle
- Initial fragment velocity
- Fragment drag coefficient curve³
- Height of fragment trajectory origin above the ground surface
- Soil constant for ricochet
- Wind speed
- Altitude of the ammunition stack site

In the Monte Carlo procedure, each replication represents one simulation of a full-scale test. For example the trajectories of the 260 fragments used to represent Mk 82 bomb pallets would constitute one replication. Each random variable associated with the fragments would have

a known or assumed range of uncertainty. Random numbers are then used to designate a particular value for each random variable. Any of the random variables may be set to a constant in FRAGHAZ. Trajectories would be calculated for each of the 260 fragments with an effective number of fragments associated with each trajectory commensurate with the number of munitions or interaction areas in the specific stack under consideration. Hazardous intersections with the target would be recorded and accumulated in the program for each 100 ft sector of the Hazard Volume. This would constitute one replication. Because of the uncertainty in the random variables, this would constitute only one possible outcome for the stack being considered. As a result, a second replication would be conducted with the 260 fragments using a new set of random numbers to define new values for the random variables. New outcomes for the 100 ft sectors of the Hazard Volume would be obtained and recorded. This procedure would continue for the number of replications selected, 60 for the data in this report. When all the replications are completed we are then in a position to calculate statistics, such as averages, for such measures of effectiveness as Hazard Density for each 100 ft range increment of the Hazard Volume.

For this report percentiles are important. In our example, we would have 60 distinct hazard densities for each 100 ft range increment. For each 100 ft range increment, we can sort the 60 values in ascending order from minimum to maximum. When sorted, the 54th highest value would be the 90th percentile value because only 6 values (ten percent of the total) would be equal to or greater than the 54th value. The 100th percentile would then coincide with the largest sorted value. We may interpret the percentile level as follows. If we are talking about a 90th percentile value, we may say that only 10 percent of the time should we expect the value to be greater than the 90th percentile value and we should not expect the value to be greater than the 100th percentile value.

HAZARD CRITERIA

In order to distinguish hazardous from non-hazardous fragments, hazard criteria must be specified beforehand. The following criteria represent the current specifications of the Department of Defense Explosives Safety Board (DDESB).

Kinetic Energy

A hazardous fragment is one that has at least 58 ft-lbs of kinetic energy when it strikes a personnel target. The DDESB is currently reviewing a criterion submitted by the Army which depends not only on mass and velocity but on the average presented area of the fragment on impact. This criterion, Continuous Probability of Injury Criterion (CPIC), which depends on skin penetration has a great deal of experimental data to support it. Some recent studies, however, indicate that the two criteria produce roughly the same results.

Hazard Density

Densities equal to or greater than one fragment per 600 ft² are considered hazardous provided all the fragments involved are hazardous in terms of the kinetic energy criterion given above. This density is predicated on a standing man having a frontal presented area of 6 ft². As such it is roughly equivalent to a probability of hazard hit of .01.

Other

Both wind and percentile level affect hazard density statistics. Currently the DDESB specifies zero wind and a 90th percentile levels for safety studies.

PROGRAM OUTPUT

The FRAGHAZ Computer Program has three basic outputs: Number of Final Ground Impacts versus Range, Hazard Density and Probability of Hit versus Range, and Number of Units Required to exceed the Density and Probability of Hit Hazard Criteria versus Range.

Number of Final Ground Impacts Versus Range

If we have 60 replications of 260 fragments then we will obtain 60 distinct distributions of final ground impacts versus range. This data can be sorted and, from it, we can obtain minimum, maximum, and average number of final ground impacts for each 100 ft increment of range. This data can be used to demonstrate the validity of the program as explained below under the FRAGHAZ COMPUTER PROGRAM VALIDATION heading.

Hazard Density and Probability of Hit

Hazard density is obtained by projecting the particular three dimensional 100 ft hazard sector, intersected by the fragment trajectory, into the plane perpendicular to the trajectory at the point of target impact. This can be done since we know the trajectory angle at all times. The projected target area is not calculated but is assumed to be a constant 6 ft² for a personnel target. The hazard density is then the number of hazard fragments associated with the particular trajectory divided by the projected area of the 100 ft hazard sector in the plane perpendicular to the fragment trajectory.

For probability of a hazardous hit, we use the hazard density calculated above and the presented area of the target in the plane perpendicular to the fragment trajectory. These two values are then used, with an appropriate equation, to calculate hazard probability of hit for the personnel target.

Since target presented area is not used in the calculation of hazard density, using the hazard density criterion will make the results look more hazardous than those calculated using a consistent probability of hazard hit criterion. This occurs because the hazard density criterion of one fragment per 600 ft² assumes the maximum presented area of a personnel target, 6 ft², which approximates a probability of hit of 0.01. With a probability of hit criterion, the presented area of the personnel target is taken into account and will almost always be less than 6 ft². In fact, it can be as low as 0.55 ft² when the fragment comes straight down on a standing man. As such, with a hazard density of 1/600, the probability of hit will almost always be less than 0.01.

Number of Units To Exceed the Hazard Criterion

Using the hazard density and probability of hit discussed above, the program can then be

used to calculate the number of units or interaction areas required to just exceed the hazard density criterion (1/600) or the hazard probability of hit criterion (.01).

FRAGHAZ COMPUTER PROGRAM VALIDATION

There is always a question with computer programs whether the predicted results obtained with the program actually match the results obtained with experimental tests. Two tests have been conducted, one with 36 pallets (288 rounds) of 155mm projectiles, and another with 1 pallet (6 bombs) of Mk 82 Bombs. After the explosion in each case, personnel were sent down-range to pick up all fragments greater than 300 grains. The terrain was marked off in 10 deg azimuthal sectors and these sectors, in turn, were marked off into 200 to 400 ft range increments. In this way each fragment could be identified with a particular azimuth sector and a range zone in the azimuth sector.

As mentioned above, the FRAGHAZ Computer Program can output the number of final fragment impacts as a function of 100 ft range increments for a particular azimuth sector. Since we had only one test for 155mm projectiles and six for Mk 82 bombs, we can not say whether the results per range increment were maximum or minimum values or some point in between. Since each replication of FRAGHAZ represents the results of an entire stack, and we run many replications (usually 60), we can obtain the minimum and maximum results expected in the actual tests. We therefore ask that the actual test results fall between the minimum and maximum values predicted by the FRAGHAZ Computer Program. In both cases there was good agreement between the predicted and actual test results.

SUMMARY

The FRAGHAZ Computer Program provides a flexible tool for predicting the fragment hazards of stacks of ammunition. The program has the inherent capability of considering the multidimensional problem posed by fragment hazards. The program is moderately large having about 1000 lines of code and over 200 variables, about 25 of which are prime variables directly affecting hazard values. Its modular characteristics make it relatively easy to modify for specific problems like the barricades considered herein. The essential characteristics of the program are summarized as follows:

- Individual three dimensional trajectories
- Two dimensional wind vectors (horizontal plane)
- Fourth Order Runge-Kutta trajectory calculations
- Fragment ricochet included for various soil types
- Incorporates three dimensional targets
- Can use different hazard criteria
- Air density and sound speed a function of altitude
- Storage sites may be at different altitudes
- Fragment drag coefficient a function of Mach Number and based on wind tunnel tests
- Predicts distribution of final fragment impacts in ground plane
- Predicts hazard density and hazard probability of hit as a function of range for different hazard levels such as minimum, maximum, average and specified

percentiles

- Predicts hazard distance values for different hazard levels (minimum, maximum, average and specified percentiles) as a function of number of units or interaction areas required to just exceed each of the two hazard criteria, density and probability of hit

PART I - GENERAL BARRICADE INVESTIGATION

PREFACE

This study was requested by the Department of Defense Explosives Safety Board (DDESB). The DDESB wanted to know if the FRAGHAZ Computer Program could be used to assist in the design and evaluation of barricades intended for use in stopping fragmentation produced by ammunition stacks. In the past, barricade studies were mostly qualitative and based on the long experience of investigators in general fragmentation characteristics.

A related purpose of the study was to demonstrate that meaningful measures of effectiveness could be produced by the FRAGHAZ program to assist in the design and evaluation of barricades. The FRAGHAZ Computer Program was modified to include the geometry and variables associated with the barricade defined below.

CONDITIONS

Barricade Model

The barricade model is shown in Figure 1. In keeping with the general nature of the study, the barricade used was a simple box type. The walls of the box barricade could be planks, the inside of which could be filled with dirt. The variables addressed in the study are also shown in Figure 1. The Stack Inert Ground Standoff is just the height of the pallet on which the munitions rest. The Barricade Face Angle determines the slope of the front face of the barricade. For this general study the front face of the barricade was vertical and the Barricade Face Angle was 90 degrees. All fragments which strike the barricade face, or the ground between stack and barricade, are considered stopped in the 0 to 100 ft range increment of the FRAGHAZ Hazard Volume. The Barricade Face Angle is too large to permit ricochet and, therefore, ricochet off the barricade was ignored. Under instruction of the DDESB, the complete or partial destruction of the barricade by the explosion of the munitions was not considered.

Munitions Selection

The two munitions selected were those for which there are fragmentation data appropriate to the FRAGHAZ Computer Program. These munitions were the Mk 82 bomb and the M107 155mm projectile. Of all the fragmentation data available, these two munitions are the most hazardous. Additionally, the Mk 82 bombs are stored horizontally while the 155mm projectiles are stored vertically. The fragmentation data available reflects this difference in storage attitude. Both sets of fragmentation data are for mass detonating munitions (Class 1, Division 1). For both munitions, only one pallet was used. For both munitions, the pallet height is approximately 2.5 ft including the pallet. As such, the barricade height is determined by this height and the values of Barricade Intercept Angle and Barricade Standoff as shown in Figure 1.

**FIGURE 1
BOX BARRICADE**

2452

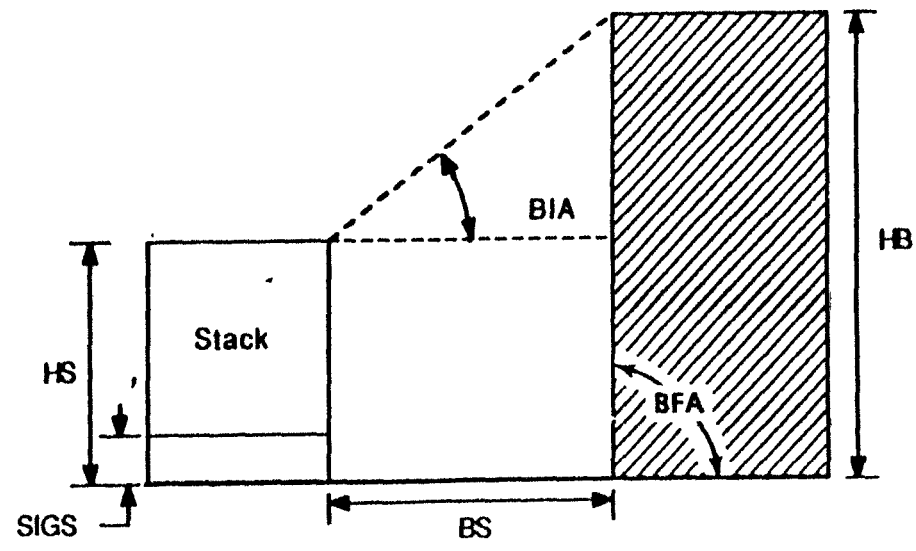

- HS - Height of Stack
- SIGS - Stack Inert Ground Standoff
- BS - Barricade Standoff
- BIA - Barricade Intercept Angle
- BFA - Barricade Face Angle (90 deg)
- HB - Height of Barricade

Hazard Criteria

Throughout this study, the target was a standing man. The Continuous Probability of Injury Criterion (CPIC) was used. This criterion depends on skin penetration and was provided by the Ballistic Research Laboratories at Aberdeen, Maryland. It is currently under review by the DDESB. Unlike the 58 ft-lbs criterion, with the CPIC criterion all fragments are hazardous to some finite level of probability and, therefore, the maximum range and the maximum hazard range will be the same. This is an advantage for the measures of effectiveness selected as described below.

The current DDESB Hazard Density Criterion of at least one hazardous fragment per 600 ft² is used. In addition zero wind is used along with 90th percentile levels.

Measures of Effectiveness

The two measures of effectiveness and associated criteria used are described below:

- The first was maximum hazard range. Since we are using the CPIC Injury Criterion, all fragments are hazardous and the maximum fragment range coincides with the maximum hazard range. This is unlike the case with the 58 ft-lbs Injury Criterion where the fragment going to maximum range may have a kinetic energy less than 58 ft-lbs and therefore would not be considered hazardous by the program. As such, maximum range and maximum hazard range could be different.
- The second measure of effectiveness is Hazard Density. This is the measure currently specified by the DDESB. For a 100 ft range increment to be hazardous, the density must be at least one fragment per 600 ft² ($1/600 = 0.001667$) and all fragments making up the density must be hazardous. Since we are using the CPIC Injury Criterion, all fragments are hazardous to a finite probability and this probability is used in calculating the reduced, or effective, Hazard Density.
- The two measures of effectiveness were calculated using zero wind and 90th percentile levels. The barricade standoff (BS in Figure 1) was held constant at 4 ft, the practical minimum specified by the DDESB. Hazards will tend to increase as BS increases.

Monte Carlo Running Option

The Monte Carlo option was used in all cases. All runs contained 60 replications. The same seed (one for each munition) was used such that the same fragment trajectories were used for each Barricade Intercept Angle. In this way, the dispersion in results with different seeds was eliminated and only the effects of different Barricade Intercept Angles are seen.

Stack Top Fragmentation

Because of the physical dimensions of the munition pallets, a part of the fragmentation from the top of the stacks was included in the arena test recovery. The exact amount of the fragmentation from the stack tops, however, is unknown. For this initial study, it is not of much

consequence since the elevation angles involved would be greater than 70 degrees. In PART II, however, where stacks may be 6 pallets deep, stack top fragmentation must be taken into account.

RESULTS

Maximum Hazard Range

The Maximum Hazard Range as a function of Barricade Intercept Angle is shown in Figures 2 and 3 for 155mm Projectiles and Mk 82 Bombs respectively. The data on these two figures represent the 90th percentile level. Maximum Hazard Ranges for the no barricade condition are also shown for reference. Barricade heights are also shown for corresponding Barricade Intercept Angles given a stack height of 2.5 ft. If the stack height were increased, say to 3 pallets high or 7.5 ft, then the barricade heights would increase 5 ft for the given Barricade Intercept Angles.

The figures show a slow and steady decline in Maximum Hazard Range for increasing Barricade Intercept Angle. There are no abrupt changes except at zero deg Barricade Intercept Angle where we experience drops from the no barricade conditions. At these conditions, the barricade height is 2.5 ft and blocks the long range fragments. In actuality, the two curves will meet to the left of the ordinate at a Barricade Intercept Angle of about -32 degrees. Negative angles were not considered because of the need to take ricochet into account from the top of the barricade.

Note in Figures 2 and 3 that a small Barricade Intercept Angle (like the 2 degrees in DoD 6055.9 - STD) does not produce a drastic reduction in Maximum Hazard Range as might have been expected. The drops, however, are significant, about 500 ft for the 155mm projectiles and 950 ft for the Mk 82 bombs.

Table 1 gives Maximum Hazard Ranges for the 50th, 90th and 100th percentile levels.

TABLE 1
MAXIMUM HAZARD RANGE (ft) FOR BOX BARRICADES *

MUNITION	155mm PROJECTILE			Mk 82 BOMB			BARRICADE HEIGHT (FEET)
	50	90	100	50	90	100	
NO BARRICADE	2300	2900	3200	2000	3300	3500	0
BIA = 0°	1900	2400	2400	1900	2400	2400	2.5
5°	1500	2300	2400	1900	2400	2400	2.9
10°	1400	2000	2400	1800	2300	2400	3.2
20°	1300	1600	2400	1700	2000	2400	4.0
30°	1200	1400	1600	1500	1800	2000	4.8
40°	1200	1400	1600	1200	1700	1800	5.9
50°	1100	1400	1600	1100	1300	1700	7.3
60°	900	1200	1500	900	1200	1400	9.4
70°	700	900	1000	700	800	1000	13.5
80°	400	600	600	300	300	400	25.2

FIGURE 2
BARRICADE EFFECTIVENESS
M107 PROJECTILES (155mm)
MASS DETONATION (CLASS 1, DIVISION 1)
VERTICAL STORAGE

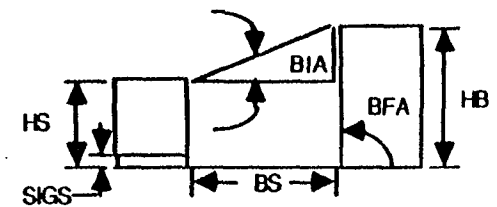
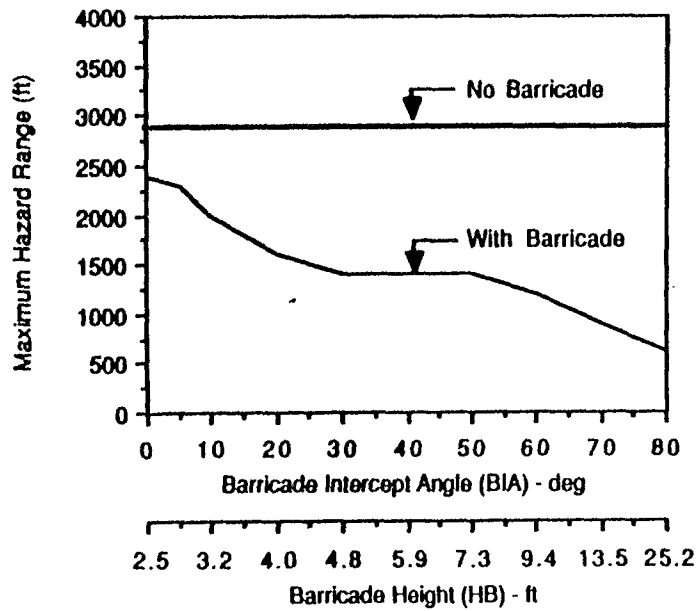

Height of Stack (HS) = 2.5 ft
 Stack Inert Ground Standoff (SIGS) = 0.5 ft
 Barricade Standoff (BS) = 4.0 ft
 Barricade Face Angle (BFA) = 90 deg

Target: Standing Man
 Monte Carlo Option
 Replications = 60
 Seed = 8271
 Sea Level
 No Wind
 Continuous Probability of Injury Criterion
 90th Percentile

FIGURE 3
 BARRICADE EFFECTIVENESS
 MK 82 LOW DRAG BOMBS (500 lb)
 MASS DETONATION (CLASS 1, DIVISION 1)
 HORIZONTAL STORAGE

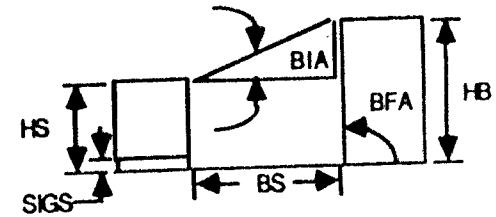
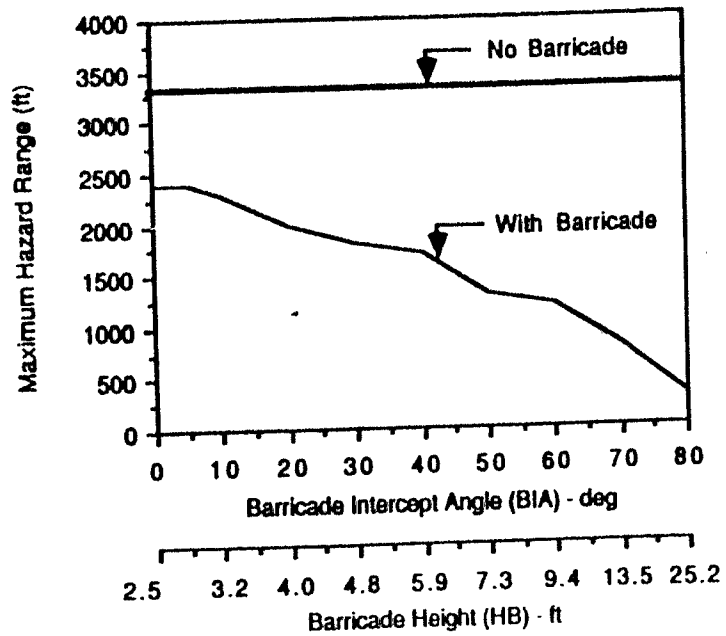

Height of Stack (HS) = 2.5 ft
 Stack Inert Ground Standoff (SIGS) = 0.5 ft
 Barricade Standoff (BS) = 4.0 ft
 Barricade Face Angle (BFA) = 90 deg

Target: Standing Man
 Monte Carlo Option
 Replications = 60
 Seed = 17351
 Sea Level
 No Wind
 Continuous Probability of Injury Criterion
 90th Percentile

* Conditions for both munitions:

Height of stack = 2.5 ft
 Stack inert ground standoff = 0.5 feet
 Barricade standoff = 4.0 ft
 Barricade face angle = 90 degrees
 Barricade intercept angle = 0 - 80 degrees

Maximum Hazard Range provides a simple and efficient measure of barricade effectiveness. It does not depend on the number of munition in the stack as Hazard Density does.

Hazard Density

Hazard Density as a function of range and Barricade Intercept Angle is shown in Figures 4 and 5 for 155mm Projectiles and Mk 82 Bombs respectively. Again, the data in these figures represent 90th percentile levels. The current DDESB Density Criterion (1 frag / 600 ft²) is given on the figures for reference. Hazard Density depends on the number of munitions or interaction areas on the face of the stack toward the target area. The data shown on Figures 4 and 5 are for one interaction area. If Hazard Densities for more than one interaction area are desired, the values given in Figures 4 and 5 can be multiplied by the number of interaction areas in question. For example, in Figure 5 the Hazard Density at a range of 2000 ft and a Barricade Intercept Angle (BIA) of 0 degrees is approximately 0.00001. If a stack had 50 interaction areas on the face of the stack toward the target area, then the Hazard Density would be 0.0005 at a range of 2000 ft and a BIA of 0 degrees. If we wished to know how many interaction areas on the face of the stack toward the target area would result in a hazard density just greater than the DDESB criterion of 1 frag per 600 ft² (0.001667), we would divide the hazard criterion by the Hazard Density for one interaction area. For the case stated of a BIA of 0 degrees at a range of 2000 ft, this would be (0.001667 / 0.00001) or 167 when rounded up to the nearest whole number. Without the barricade, this number would be reduced to about (0.001667 / 0.00003) or 56 interaction areas which we might say is about three times more hazardous.

Hazard Density might be more properly called Injury Density when using the Continuous Probability of Injury Criterion (CPIC). The Hazard Density Criterion (1/600) is used to approximate the probability of hit criterion. The Hazard Density is defined as follows:

$$\text{Hazard Density} = (\text{NF} / \text{AT}) * \text{P} (\text{INJ} / \text{HIT})$$

where

NF = Number of hazardous fragments
 AT = Presented area of the hazard volume of a 100 ft range segment
 in the plane perpendicular to the fragment trajectory
 P (INJ / HIT) = Conditional probability of injury given a hit
 * = Multiplication

With the 58 ft-lbs injury criterion, the probability of injury is either zero or one as the impacting fragment has less than 58 ft-lbs or at least 58 ft-lbs of kinetic energy respectively.

**FIGURE 4
BARRICADE EFFECTIVENESS
M107 PROJECTILES (155mm)
MASS DETONATION (CLASS 1, DIVISION 1)
VERTICAL STORAGE**

2458

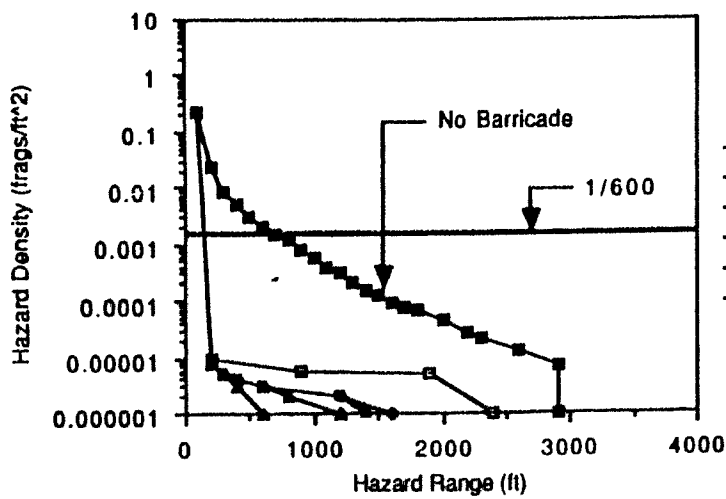

- BIA**
- 0°
 - ◆ 20°
 - ▲ 40°
 - ▼ 60°
 - ▲ 80°
 - No Barricade

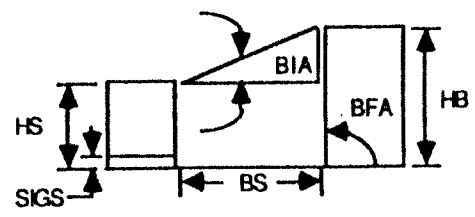

Height of Stack (HS) = 2.5 ft
 Stack Inert Ground Standoff (SIGS) = 0.5 ft
 Barricade Standoff (BS) = 4.0 ft
 Barricade Face Angle (BFA) = 90 deg
 Barricade Height (See Figure 2)
 Barricade Intercept Angle (BIA) = 0° - 80°

Target: Standing Man
 Monte Carlo Option
 Replications = 60
 Seed = 8271
 Sea Level
 No Wind
 Continuous Probability of Injury Criterion
 90th Percentile

One Interaction Area

**FIGURE 5
BARRICADE EFFECTIVENESS
MK 82 LOW DRAG BOMBS (500 lb)
MASS DETONATION (CLASS 1, DIVISION 1)
HORIZONTAL STORAGE**

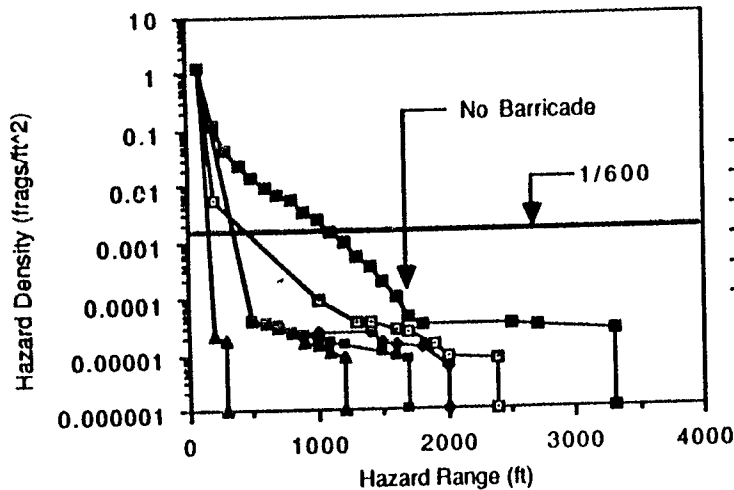
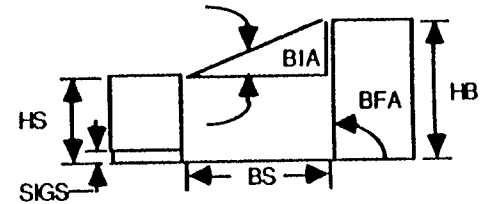

- BIA**
- 0°
 - 20°
 - 40°
 - ▲ 60°
 - △ 80°
 - No Barricade

Height of Stack (HS) = 2.5 ft
 Stack Inert Ground Standoff (SIGS) = 0.5 ft
 Barricade Standoff (BS) = 4.0 ft
 Barricade Face Angle (BFA) = 90 deg
 Barricade Height (See Figure 4)
 Barricade Intercept Angle (BIA) = 0° - 80°

Target: Standing Man
 Monte Carlo Option
 Replications = 60
 Seed = 17351
 Sea Level
 No Wind
 Continuous Probability of Injury Criterion
 90th Percentile

One Interaction Area

2459

CONCLUSIONS

- The FRAGHAZ Computer Program can be adapted to evaluate the design and effectiveness of barricades.
- More complex barricade designs and effects of ricochet can be considered by the FRAGHAZ Computer Program.
- The FRAGHAZ Computer Program can be used to determine shapes and dimensions for barricades to meet specific design criteria. For example, it might be desirable to design a barricade to limit down-range hazardous fragments to the hazard blast radius for a specific ammunition stack.

PART II - SPECIFIC HILLSIDE BARRICADE INVESTIGATION

PREFACE

The investigation contained herein was conducted in response to a request made by the Air Force. The letter containing the request is reproduced in Appendix C. Correspondence subsequent to the request provided details on the site necessary to conduct the investigation. The site is located at Taegu Air Base in Korea.

The Air Force requested that the clear zone for fragments about a storage shed be reduced from 1250 ft to something nearer 800 ft because of a natural hill barricade surrounding the shed on three sides. Although the shed is used for handling a variety of munitions, it has been stated that six Mk 82 Bomb pallets (36 bombs) would be taken as the source of the maximum hazard for the investigation.

The FRAGHAZ Computer Program was modified to include the site geometry and munition fragmentation characteristics of Mk 82 Bomb pallets. The Mk 82 Bomb weighs 500 pounds.

CONDITIONS

Stack Configurations

Six stack configurations were used as shown in Figure 6. They were selected to provide minimum and maximum fragmentation hazards for both side and top interaction areas. Configurations 1 and 5 provide maximum and minimum hazards for side interaction areas respectively. Configurations 3 and 5 provide minimum and maximum hazards for top interaction areas respectively. The remaining configurations provide intermediate hazards which give information on transition from minimum to maximum hazards.

Information from the Air Force stated that a maximum of six Mk 82 Bomb pallets (36 bombs) could be stored in the shed (Building 230) at Taegu Air Base in Korea. The six configurations shown in Figure 6 represent rectangular parallelepiped stacking of the 6 pallets. Configurations where the number of pallets would differ in different tiers were not considered since they would only involve intermediate hazard conditions between the six configurations selected.

Since the height of the shed is about 10 ft, the maximum height of any stack was taken to be 7.5 ft; that is, 3 pallets high. The height of an individual pallet is about 2.5 ft.

The abbreviations associated with each stack configuration in Figure 6 are explained as follows:

HS = Height of stack.

SIA = Number of side interaction areas used in the calculation of Hazard Densities. With the hill barricade (w/hill), only the interaction areas of the top layer of the pallets are used. The fragmentation from the interaction

FIGURE 6
STACK CONFIGURATIONS
KOREAN HILLSIDE BARRICADE: TAEGU: BUILDING 230
6 PALLETS MK 82: 6 BOMBS PER PALLET

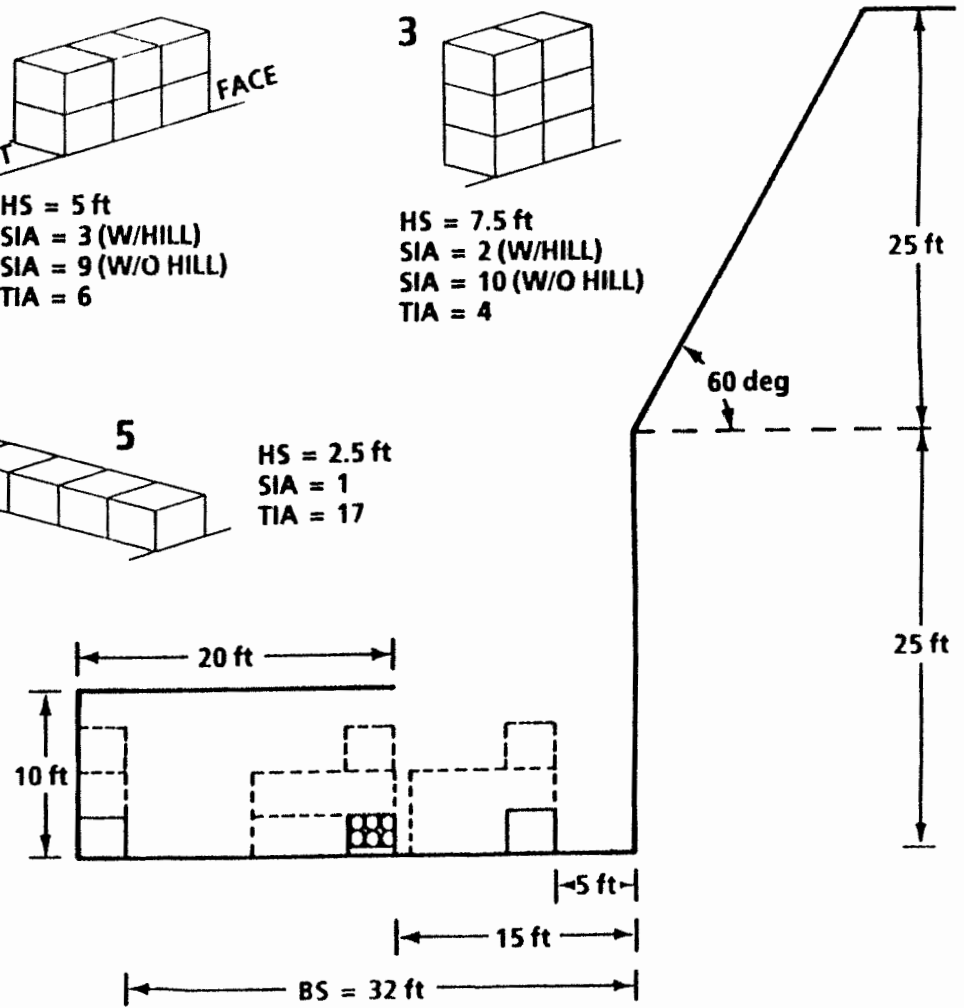
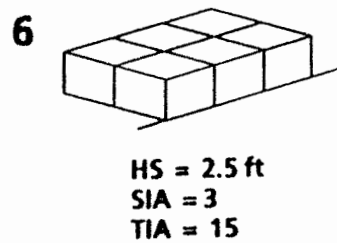
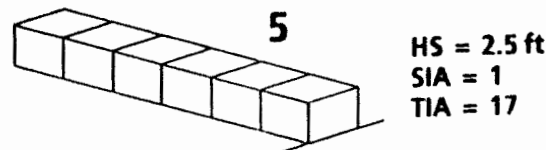
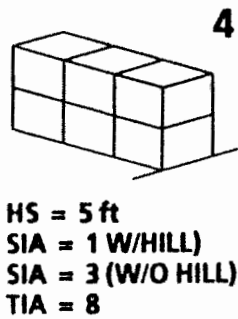
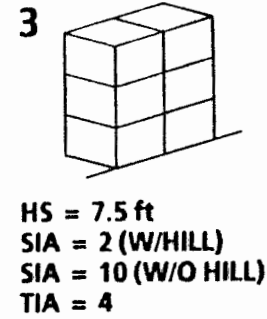
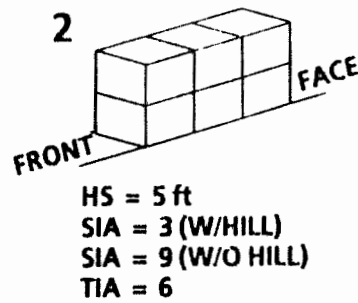
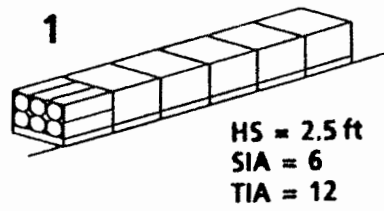

2462

areas of lower layers will be stopped by the hillside barricade. The top layer includes not only the interaction area fragments from the bomb case zone A-B-C in Figure 7 but also fragmentation from the zone C-D. Without the hill (w/o hill), all interaction areas on the face of the stack, including those formed by adjacent pallets, are pertinent to the calculations. When pallets are stacked on top of one another, an additional interaction area is formed between pallets.

TIA = Number of interaction areas on the top of the stack including those formed by adjacent pallets. When pallets are positioned next to one another with long bomb axis to long bomb axis, then an additional interaction area is formed between pallets. If the pallets are positioned bomb base to bomb base, nose to nose, or nose to base then no additional interaction areas are formed.

The effects of blast pressures from any of the stacks were not considered in the hazard calculations.

Site Configuration

The essentials of the site configuration used for hazard calculations are shown in Figure 6. The hillside barricade consists of two legs, one vertical and one angled back at 60 degrees. Fragment ricochet was considered on the leg angled back at 60 degrees. A soil constant of 1.1 was used which is appropriate for cohesive soils supporting vegetative growth.

The effects of the shed structure on fragment trajectories were not considered. The effects are considered minor. Ignoring shed effects might even tend to err against the side of safety since the shed structure could be the source of additional fragments, although such fragments would probably have poor aerodynamic characteristics.

The site altitude used in the hazard calculations was 150 ft above sea level. Even if this altitude is off by a few hundred ft, the effects on the overall calculations would be negligible.

Three distances for positioning the stacks relative to the hillside were used. A barricade standoff (BS) of 32 ft as shown in Figure 6 corresponds to a stack position at the back of the shed. A BS of 15 ft is for a stack position at the front of the shed. The barricade standoff of 5 ft was used to determine whether a significant reduction in fragment hazards could be obtained that might justify a change in storage location.

Hazard Criteria

The target for this investigation was a standing man. The 58 ft-lbs Injury Criterion, currently specified by the DDESB, was used to distinguish hazardous from non-hazardous fragments. The Continuous Probability of Injury Criterion (CPIC) was used for comparison purposes. CPIC was provided by the Army and is currently under review by the DDESB.

A Hazard Density of one hazardous fragment per 600 ft², currently specified by the DDESB, was used as the limit above which Hazard Density is considered unacceptable for safety purposes by the DDESB.

FIGURE 7
FRAGMENTATION ELEVATION ZONES
KOREAN HILLSIDE BARRICADE: TAEGU: BUILDING 230

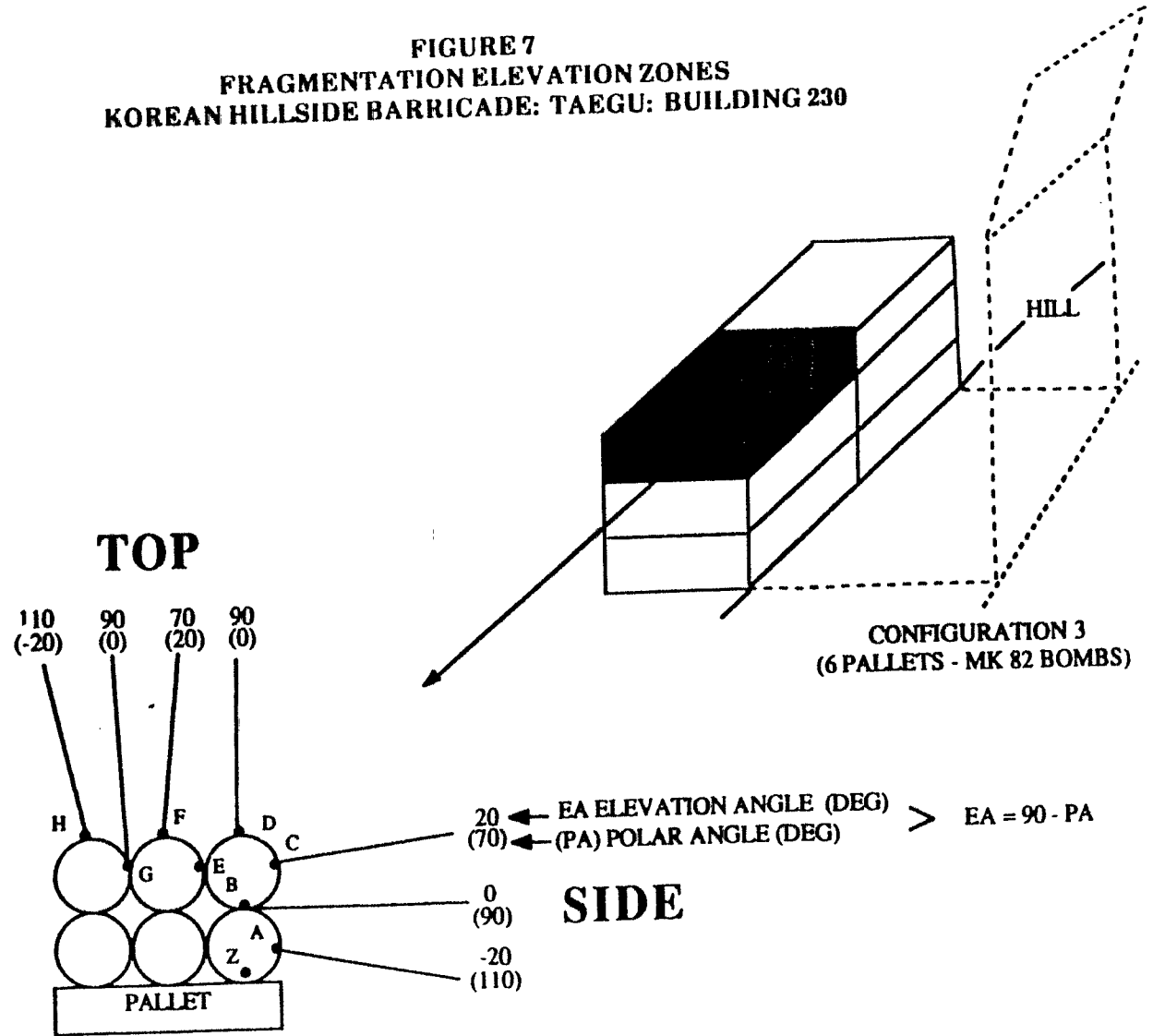

2464

Zero wind and the 90th percentile level were also used as standard conditions for safety analysis as currently specified by the DDESB.

Side and Top Fragmentation

The zones for side and top fragmentation are shown in Figure 7. Side fragmentation comes from the bomb case portion labelled Z-A-B-C-D. The side interaction area is taken to come from A-B-C where the fragment densities and velocities are highest. In the arena test from which the fragmentation characteristics used in this investigation were taken, the pallet of Mk 82 Bombs was positioned so as to recover the fragmentation from the side area. At the time, it was assumed that all fragmentation going down-range came from the face of the stack toward the target area. Reviewing the arena test data, however, showed that fragments with interaction area velocities were recovered between polar angles 10 and 30 degrees. These fragments must almost certainly come from the top interaction area zone D-E-F. Whether some of this fragmentation might also have come from top interaction area zone F-G-H is unknown. Because of this uncertainty and for the sake of safety, the side and top fragmentation were taken to be exclusive of one another. That is, the fragmentation recovered in the arena test was taken to come from the bomb case zone Z-A-B-C-D only. Adopting such a procedure may result in some double counting of fragments but any error should tend to be on the side of safety.

The top fragment interaction areas were taken to be similar to the side interaction area A-B-C. In reality, much depends on where the stack is initiated. In the arena test, the middle bomb of the lower tier was the donor bomb making the interaction area A-B-C to be skewed upwards. In practice, the initiation point for a stack will be unknown. As such, we have used an average such that the bomb case zone A-B-C is taken to produce an interaction area between polar angle 70 and 110 degrees (elevation angles plus or minus 20 degrees). This zone then becomes the model for the top interaction areas. Each top interaction area is taken to be independent since we have no test data on the interaction of interaction areas. The arena test was conducted with only one interaction area, A-B-C. However, this same type of independence was used with 155mm projectiles which had six interaction areas in the arena test and good results were obtained.

The top interaction areas were defined by rotating the side interaction area, A-B-C, 90 degrees such that elevation angle -20 degrees became elevation angle 70, and elevation angle 20 degrees became elevation angle 110. The top interaction areas have a spread of 40 degrees like the side interaction area. When making such a 90 deg rotation, account must be taken of a diminished number of fragments which are applicable to the 10 deg Hazard Volume. When recovering fragments in the arena, the vertical extent of the recovery packs at any elevation angle between the 10 deg azimuthal limits is approximately:

$$H = 2 * R * \text{TAN}(5^\circ) * \text{ABS}(\text{COS}(E))$$

where

H	=	Distance between azimuthal limits
R	=	Radius of the arena
E	=	Elevation angle in degrees
*	=	Multiplication

When we rotate toward polar angle 0 (elevation angle 90), the distance between the azimuthal limits decreases, finally becoming zero at polar angle 0 degrees (elevation angle 90). Since only those fragments whose initial trajectories are constrained between the azimuthal limits will end up in the 10 deg Hazard Volume, we must take this into account by diminishing the number of fragments recovered from the polar zone 70 to 110 which we rotate 90 degrees to form top interaction areas. The reduction factors used were 0.25 for the 70 to 110 degree top interaction area elevation zone, and 0.1 for the 80 to 90 top interaction area elevation zone.

In the investigation, the Hazard Densities were calculated independently for the side and top fragmentation and then summed for total Hazard Density. Linear scaling was used for multiple interaction areas; that is, Hazard Densities were calculated for one interaction area and then multiplied by the number of interaction areas for the particular stack configuration to obtain total Hazard Densities.

Wind

The DDESB currently specifies zero wind for safety analysis. Two other wind conditions were used for reference. These were a 30 ft/sec tailwind (20.5 MPH) and 60 ft/sec tailwind (40.9 MPH). A tailwind tending to push the fragments directly down-range is almost always the most hazardous. A 30 ft/sec wind corresponds to fair weather gusting. A 60 ft/sec wind corresponds to gusting associated with electrical storms.

Monte Carlo Running Option

The Monte Carlo option of the FRAGHAZ Computer Program was used in all cases. All runs contained 60 replications. The same seed was used in all cases such that the same fragment trajectories were used for all six stack configurations and the alternate conditions studied. In this way, the dispersion in results with different seeds was eliminated and only the effects of the different stack configurations and alternate conditions were obtained.

RESULTS

The results of this investigation are given in the tables of Appendices A and B. In all cases, the measure of effectiveness is Hazard Density. The ranges given in these tables are the upper bound of the 100 ft sectors of the Hazard Volume; that is, a range of 300 denotes the 200 to 300 ft sector, a range of 1200 ft denotes the 1100 to 1200 ft sector and so forth. The tables of Appendices A and B represent a wide variety of conditions which are intended to lend scope to the investigation and provide a broad basis for evaluating the request made by the Air Force in Appendix C. In order to provide a graphic picture of the results, selected data from the tables of Appendix A and B have been plotted in Figures 8 through 15. These figures show the effect on results caused by changes in hazard criteria and other alternate conditions. When plotting these figures, the Hazard Densities for the 0 to 100 ft sectors have not been plotted. These densities are extremely large since they include the hazards from all the fragments stopped by the hill. A discussion of the results shown in Figures 8 through 15 is given below.

Figure 8: Baseline Hazard Densities

Figure 8 shows three curves, one for each of the three tailwind speeds (0, 30 and 60 ft/sec). The curve for a tailwind speed of 0 ft/sec is the baseline and will be the curve used as a basis of comparison for most of the succeeding curves. The baseline curve is considered the best estimate of Hazard Densities for Stack Configuration Number 3 (the least hazardous configuration given in Tables A-1 through A-9) under the hazard criteria and conditions currently specified by the DDESB as listed in Figure 8. Note that the barricade (hill) standoff is 32 ft which corresponds to the back of the shed. This position causes a slightly higher hazard than the other two standoffs - 15 and 5 ft. All the remaining curves in this figure and in Figures 9 through 15 are for comparison with this baseline curve and to lend scope to the investigation by showing the effects of different hazard criteria and conditions.

The baseline curve is taken from Table A-1, data column 6. The curve for 30 ft/sec tailwind is taken from Table A-4, data column 6. The curve for 60 ft/sec tailwind is taken from Table A-7, data column 6.

Note that the ordinate of Figure 8, and succeeding figures, is graduated with a log scale. Most of us are more accustomed to the usual linear scale graduations and this can be a problem when estimating how many times greater one point is than another. For example, the threshold safety hazard density (one fragment per 600 ft²) shown as a thick horizontal line at Hazard Density 0.001667 appears to be about 1.3 times greater than the baseline Hazard Density at 200 ft range. Actually the baseline Hazard Density at 200 ft range is 0.000449 from Table A-1 and, therefore, the threshold safety hazard density is $(0.001667 / 0.000449)$ or 3.7 times greater. The threshold safety hazard density appears about 2.4 times greater than the baseline Hazard Density at 1400 ft range while actually it is $(0.001667 / 0.000084)$ or 19.8 times greater.

Since we have always tended to err on the side of safety when we encountered uncertainties, the Hazard Densities for the baseline conditions represent a large factor of safety relative to the threshold safety hazard density. We might say from the above calculations that the factor of safety ranges from about 3 to 20 depending upon range. For the approximate safety range of 800 ft, requested in Appendix C, the factor of safety would be about 18.

From Figure 8, we can also see that tailwind speed does not have a very large effect relative to the threshold safety hazard density. The tailwind curves for 30 and 60 ft/sec are still well below the one fragment per 600 ft² (0.001667) threshold.

Figure 9: Minimum and Maximum Hazard Configurations

Figure 9 shows minimum and maximum Hazard Density curves for Stack Configurations 3 and 5 respectively. Actually, there is a crossover at about 1200 ft range due to the fact that Configuration 5 has half as many side interaction areas as Configuration 3 (see discussion on Figure 14 for side and top contributions). The Configuration 3 curve is taken from Figure 8 and Table A-1, data column 6. The Configuration 5 curve is taken from Table A-1, data column 10. Configuration 5, see Figure 6, represents a non-compact stack of 6 pallets and is somewhat analogous to scattering single pallets around the shed floor. Figure 9 indicates the need for arranging the pallets in compact stacks like Configuration 3, especially when hazard ranges of interest are less than about 1000 ft.

Figure 8

Baseline Hazard Densities

Korean Hillside Barricade : TAEGU : Bldg 230
Stack Configuration No. 3

Target - Standing Man : Injury Criterion - Kinetic Energy Threshold = 58 ft-lbs
Monte Carlo Option : Replications 60 : Seed 17351 : Site Altitude 150 ft
Stack Top Vertical Fragmentation Elevation Zone = 70 - 110 Deg
90th Percentile : Stack Barricade (Hill) Standoff = 32 ft

2468

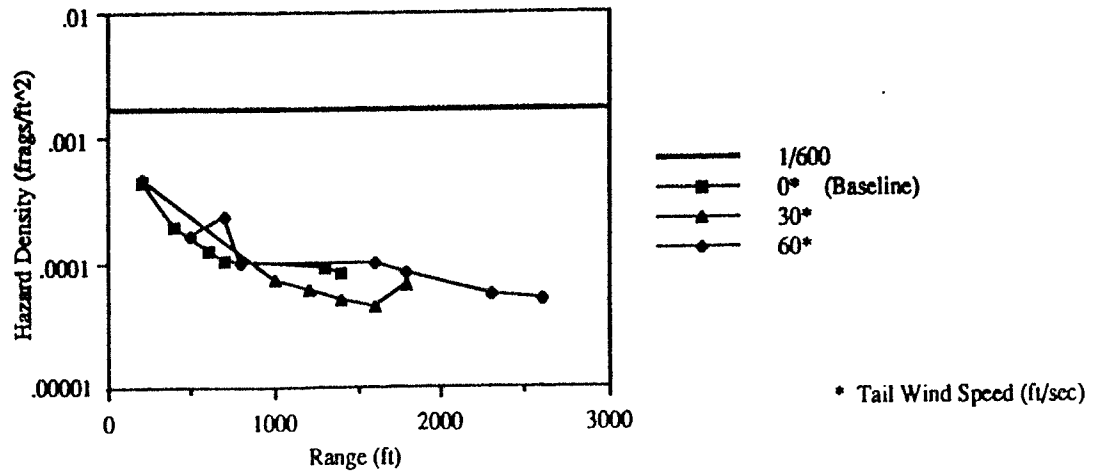

Figure 9

Minimum and Maximum Hazard Configurations

Korean Hillside Barricade : TAEGU : Bldg 230

Target - Standing Man : Injury Criterion - Kinetic Energy Threshold = 58 ft-lbs
Monte Carlo Option : Replications 60 : Seed 17351 : Site Altitude 150 ft
Stack Top Vertical Fragmentation Elevation Zone = 70 - 110 Deg
90th Percentile : Stack Barricade (Hill) Standoff = 32 ft : Zero Wind

2469

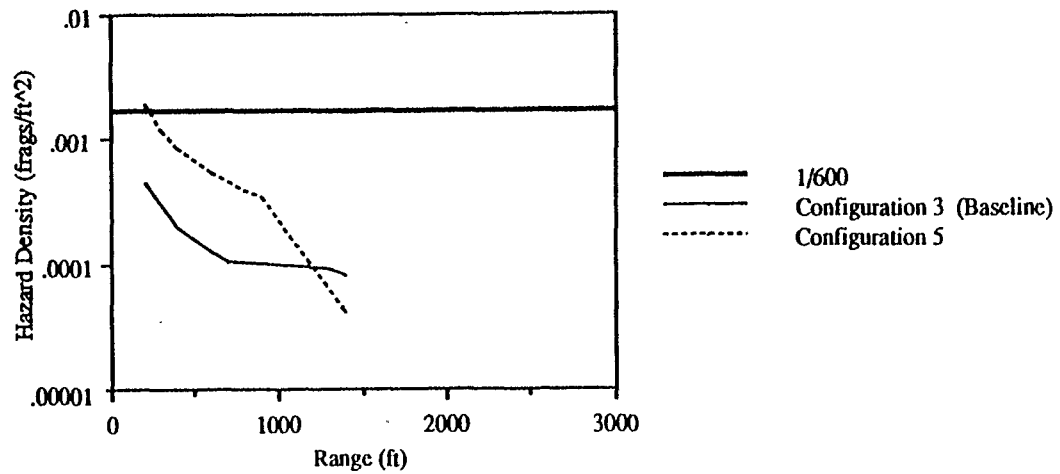

Figure 10: Hazard Densities for 58 ft-lbs and CPIC Injury Criteria

Figure 10 shows the baseline curve (Table A-1, data column 6) and a second curve (Table A-10, data column 6) for the same conditions except that the baseline personnel injury criterion of 58 ft-lbs has been changed to the Continuous Probability of Injury Criterion (CPIC). As shown in Figure 10, the effect of the change is small, both curves being well below the threshold safety hazard density of one hazardous fragment per 600 ft² (0.001667).

Figure 11: 90th Versus 100th Percentile Hazard Densities

Figure 11 shows results with the baseline Configuration 3 stack at two percentile levels, 90 and 100. The baseline curve is taken from Table A-1, data column 6. The 100th percentile curve is taken from Table A-1, data column 5. The 90th percentile curve represents the level of Hazard Densities which we expect to be exceeded only 10 percent of the time. Of that 10 percent of the time, the 100th percentile represents the maximum level expected. The curves are close and well below the threshold safety hazard density of one hazardous fragment per 600 ft² (0.001667).

Figure 12: Hazard Densities With and Without Hill

Figure 12 shows the results with Stack Configuration Number 3 for the case of no hill as opposed to the baseline case with the hill. The baseline data with the hill are taken from Table A-1, data column 6. The data for the case without the hill are taken from Table B-1, data column 2. The case without the hill implies a flat and horizontal plane extending from the stack down-range. The curve for the case of no hill shows Hazard Density exceeding the DDESB limit (one hazardous fragment per 600 ft²) out to about 1400 ft. Configuration Number 3, however, is not the best stack configuration for the case without the hill. Another study would have to be performed to define the stack configuration which would be best for open terrain. The use of Configuration Number 3 is for comparison but probably represents a near maximum hazard for open terrain.

In Appendix C, the Air Force stated that the storage shed is surrounded on three sides by the hill. The fourth is apparently open but blocked to some extent by an undefined barricade. Since Hazard Densities for the fourth side would probably fall between the two curves shown in Figure 12, calculations should be made when the stack-barricade geometry for the fourth side becomes available.

Figure 13: Hazard Densities for 0 and 58 ft-lbs Injury Criteria

Figure 13 shows the effect of an ultra-conservative personnel injury criterion. The baseline curve is taken from Table A-1, data column 6. The 0 ft-lbs injury criterion curve is taken from Table B-3, data column 2. With the 0 ft-lbs injury criterion, every fragment has a probability of injury of 1. Actually, every fragment has a kinetic energy greater than 0 at impact because the impact velocity is always greater than 0. Selecting 0 ft-lbs as the criterion insures that every fragment will be hazardous when we do not know the minimum kinetic energy at impact. This figure is designed to show an extreme point of reference.

Figure 10

Hazard Densities for 58 ft-lbs and CPIC Injury Criteria

Korean Hillside Barricade : TAEGU : Bldg 230
Stack Configuration No. 3

Target - Standing Man

Monte Carlo Option : Replications 60 : Seed 17351 : Site Altitude 150 ft
Stack Top Vertical Fragmentation Elevation Zone = 70 - 110 Deg
90th Percentile : Stack Barricade (Hill) Standoff = 32 ft : Zero Wind

2471

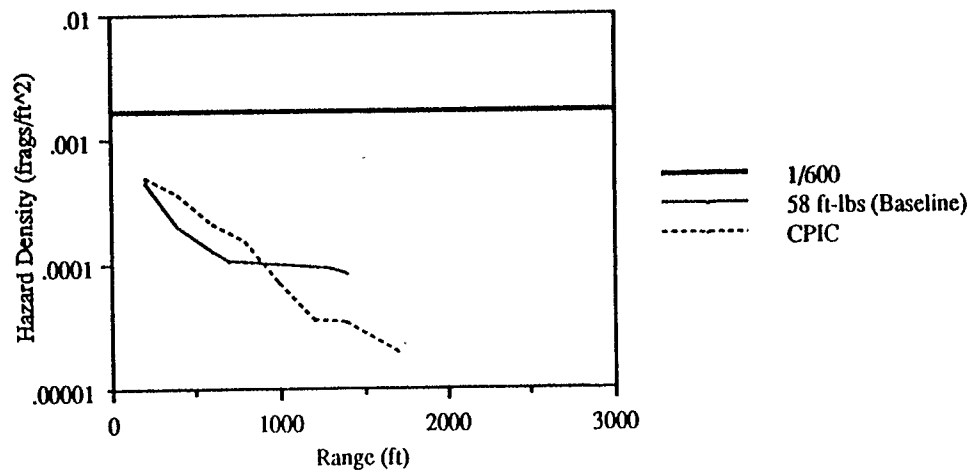

Figure 11

90th versus 100th Percentile Hazard Densities

**Korean Hillside Barricade : TAEGU : Bldg 230
Stack Configuration No. 3**

**Target - Standing Man : Injury Criterion - Kinetic Energy Threshold = 58 ft-lbs
Monte Carlo Option : Replications 60 : Seed 17351 : Site Altitude 150 ft
Stack Top Vertical Fragmentation Elevation Zone = 70 - 110 Deg
Stack Barricade (Hill) Standoff = 32 ft : Zero Wind**

2472

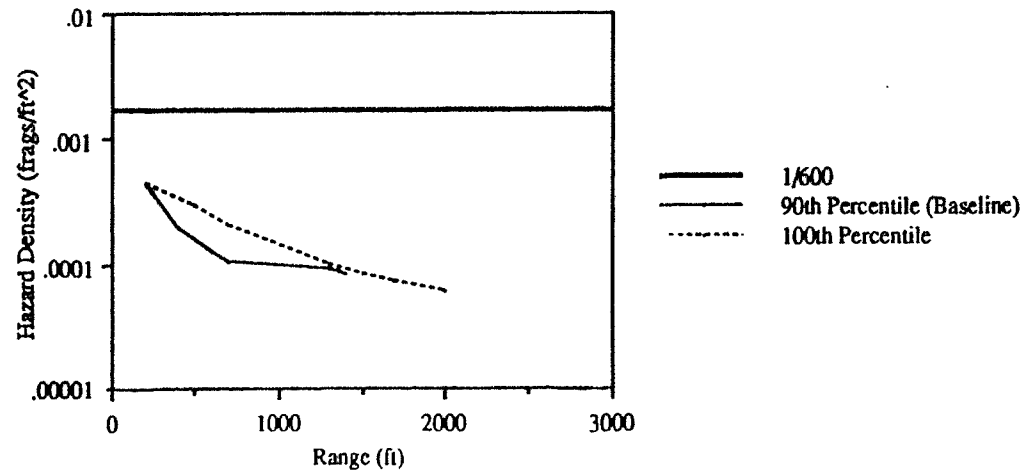

Figure 12

Hazard Densities With and Without Hill

Korean Hillside Barricade : TAEGU : Bldg 230
Stack Configuration No. 3

Target - Standing Man : Injury Criterion - Kinetic Energy Threshold = 58 ft-lbs
Monte Carlo Option : Replications 60 : Seed 17351 : Site Altitude 150 ft
Stack Top Vertical Fragmentation Elevation Zone = 70 - 110 Deg
90th Percentile : Stack Barricade (Hill) Standoff = 32 ft : Zero Wind

2473

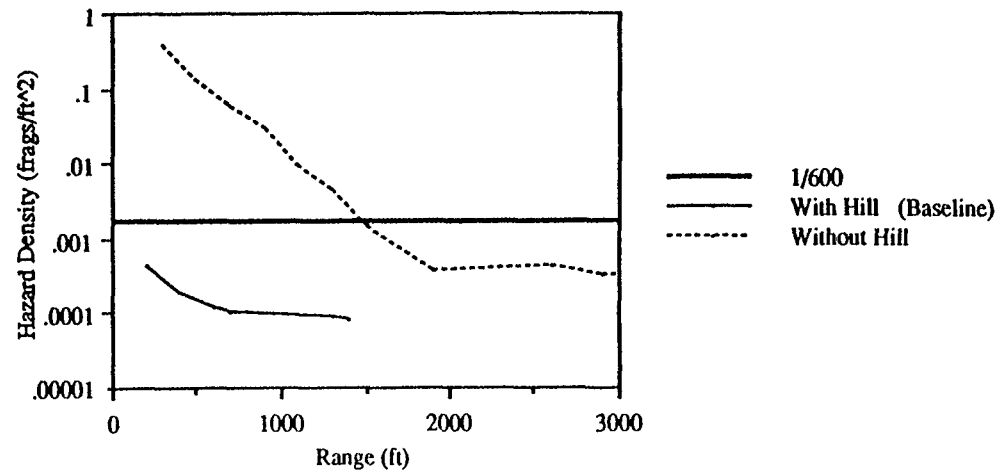

Figure 13

Hazard Densities for 0 and 58 ft-lbs Injury Criteria

Korean Hillside Barricade : TAEGU : Bldg 230
Stack Configuration No. 3

Target - Standing Man

Monte Carlo Option : Replications 60 : Seed 17351 : Site Altitude 150 ft
Stack Top Vertical Fragmentation Elevation Zone = 70 - 110 Deg
90th Percentile : Stack Barricade (Hill) Standoff = 32 ft : Zero Wind

2474

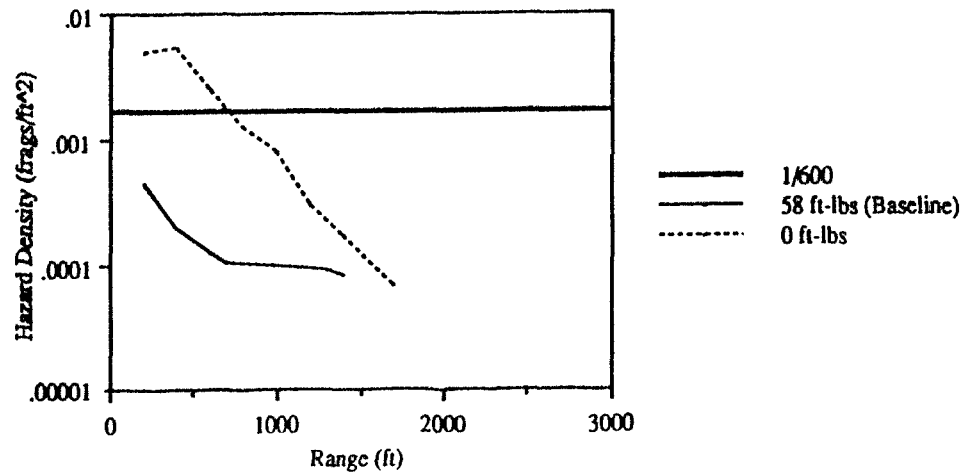

Figure 14: Hazard Density Contributions From Side and Top Fragmentation

The side fragmentation curve is taken from Table B-2, sheet 1, data column 3. The top fragmentation curve is taken from Table B-2, sheet 1, data column 4. It is interesting to note that the two contributions do not overlay in range. These two curves together form the baseline curve but shows a range gap. In the previous figures, the baseline curve showed these two regions connected to make a smooth, continuous curve. The figure shows that the hill is doing an excellent job of blocking the side fragmentation. See Figure 7 for a description of side and top fragmentation.

If the baseline curve had been calculated with the stack positioned at the front of the shed, the contribution from the side fragmentation would be zero beyond 100 ft range (see Table B-5, sheet 1, data column 6). As such, the baseline curve would terminate at 900 ft range, as shown in Table A-2, data column 6.

Figure 15: Hazard Densities For Vertical Fragmentation Elevation Zones 70 - 110 and 80 - 90 Deg

The 70 - 110 degree baseline elevation zone results are taken from Table A-1, data column 6. The 80 - 90 elevation zone results are taken from Table B-4, data column 2. In the fragmentation arena tests, only one interaction area was involved. In deriving the top fragmentation from the side fragmentation we do not know the elevation zone width for two or more interaction areas making up the top fragmentation. The two elevation zone widths shown in Figure 15 are the best estimates of the maximum and minimum zone width. From Figure 15, the selection of the 70 - 110 deg zone width for the baseline configuration should err on the side of safety. The reason that the two curves come together at approximately 1400 ft range is that beyond 900 ft range only the side fragmentation is involved and the total Hazard Density beyond 900 ft is therefore independent of the top fragmentation.

Probability of Hazard Hit

The Hazard Density threshold (one hazardous fragment per 600 ft²) was selected to produce a threshold probability of hazard hit of approximately 0.01 when the presented area of the personnel target was 6 ft². In this investigation with the hill, the angle of fall for all fragments is very steep and the presented area of the standing man is much less than 6 ft²; it is more nearly 1 ft². With the hill and with zero wind, a rough estimate of probability of hazard hit may be obtained by multiplying Hazard Density by 0.65. If a probability of hazard hit criterion were used, the results would have appeared much less hazardous. If, however, we had used a prone man instead of a standing man then the results would have appeared pretty much the same.

Positioning the Stacks

In terms of top fragmentation, there is very little effect due to the positions of the stacks relative to the hill. In terms of side fragmentation, however, there is some effect (see Table B-5). Positioning the stack near the front of the shed (BS = 15 ft) is better than positioning it at the back of the shed (BS = 32 ft). There is little or no advantage in positioning the stack outside the shed nearer to the hill.

Figure 14

Hazard Density Contributions From Side and Top Fragmentation

Korean Hillside Barricade : TAEGU : Bldg 230
Stack Configuration No. 3

Target - Standing Man : Injury Criterion - Kinetic Energy Threshold = 58 ft-lbs
Monte Carlo Option : Replications 60 : Seed 17351 : Site Altitude 150 ft
Stack Top Vertical Fragmentation Elevation Zone = 70 - 110 Deg
90th Percentile : Stack Barricade (Hill) Standoff = 32 ft : Zero Wind

2476

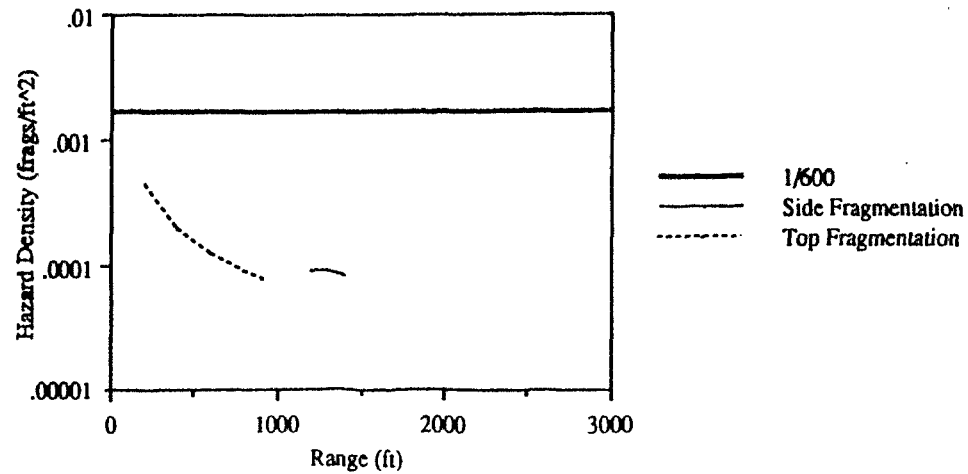

Figure 15

Hazard Densities for Vertical Fragmentation Elevation Zones of 70 - 110 and 80 - 90 Deg

Korean Hillside Barricade : TAEGU : Bldg 230
Stack Configuration No. 3

Target - Standing Man : Injury Criterion - 58 ft-lbs Kinetic Energy Threshold
Monte Carlo Option : Replications 60 : Seed 17351 : Site Altitude 150 ft
90th Percentile : Stack Barricade (Hill) Standoff = 32 ft : Zero Wind

2477

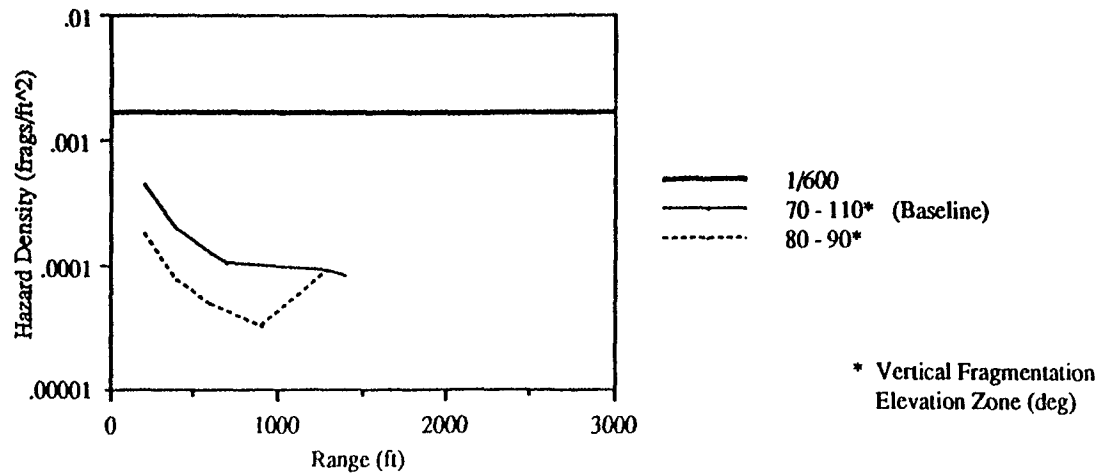

CONCLUSIONS

The following conclusions may be drawn from the results of this investigation.

- The pallets of Mk 82 Bombs should be stacked in a compact configuration like Configuration Number 3 shown in Figure 6.
- The stack should be positioned as near to the front of the shed as practical. There is very little advantage in positioning the stack outside the shed and nearer to the hill (see Table B-5).
- The baseline Stack Configuration Number 3 provides a significant margin of safety (see Figure 8) under the hazard criteria currently specified by the Department of Defense Explosives Safety Board (DDESB). At 800 ft range, the margin of safety is about 18 for zero wind.
- The presence of tailwinds do not significantly alter the margins of safety (see Figure 8). The tailwind curves are still well below the threshold hazard of one hazardous fragment per 600 ft².
- Since the investigation tended to err on the side of safety when uncertainties arose, hazards are not expected to exceed those shown in Figures 8 through 15.
- The hill does an excellent job of stopping the fragmentation from the side of the stacks, especially when the stacks are positioned at the front of the shed (see Table B-5). The hill has little or no effect on the fragmentation coming from the top of the stacks.
- In the Air Force request, contained in Appendix C, it was stated that the storage shed was surrounded on three sides by a hill with the fourth side open and blocked by an undefined barricade. This fourth side should be investigated when detailed data on the stack-barricade geometry become available. It is possible that a compromise stack configuration may be necessary to minimize the overall hazard.

REFERENCES

1. McCleskey, Frank, Quantity Distance Fragment Hazard Computer Program (FRAGHAZ), Naval Surface Warfare Center, TR 87-59, February 1988
2. Reeches, Mark, Fragment Ricochet from Homogeneous Soils and Its Effects on Weapon Lethality (U), Army Material Systems Analysis Agency Technical Memorandum Number 79, August 1970 (CONFIDENTIAL)
3. McCleskey, Frank, Drag Coefficients for Irregular Fragments, Naval Surface Warfare Center, TR 87-89 February 1988

