



US Army Corps
of Engineers®
Engineer Research and
Development Center

Navigation Systems Research Program

Force Time History During the Impact of a Barge Train with a Lock Approach Wall Using Impact_Force

Robert M. Ebeling, Barry C. White, Abdul N. Mohamed,
and Bruce C. Barker

June 2010

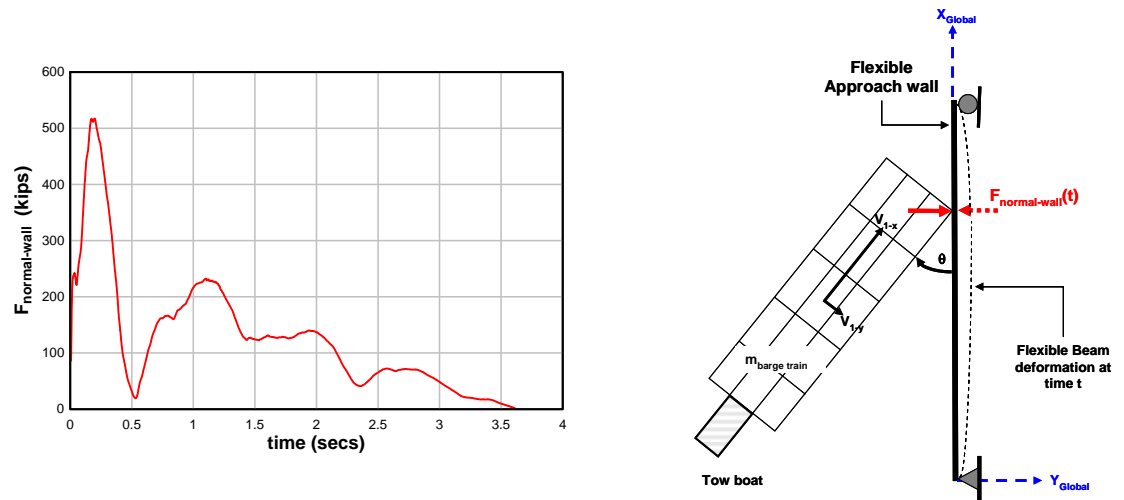

Force Time History During the Impact of a Barge Train with a Lock Approach Wall Using Impact_Force

Robert M. Ebeling, Barry C. White, Abdul N. Mohamed, and Bruce C. Barker

*Information Technology Laboratory
U.S. Army Engineer Research and Development Center
3909 Halls Ferry Road
Vicksburg, MS 39180-6199*

Final report

Approved for public release; distribution is unlimited.

Prepared for U.S. Army Corps of Engineers
Washington, DC 20314-1000

Under Work Unit J4J37B

Abstract: To conduct a dynamic structural response analysis of flexible approach walls at Corps locks using structural dynamics engineering computer programs, a force time history is needed to represent the impact of a barge train with the approach wall. This technical report describes an engineering methodology used to create this pulse force time history normal to the wall. This engineering methodology is implemented with a PC-based FORTRAN program and visual modeler named Impact_Force. The engineering formulation for Impact_Force uses existing pulse data or synthetic pulse data and the impulse momentum principle to convert the linear momentum of a barge train into a pulse force time history acting normal to the approach wall. Included in this effort is the interpretation of the results from the 1997 full-scale barge train impact prototype experiments conducted at Old Lock and Dam 2 just north of Pittsburgh, PA, and of the 2008 full-scale barge train impact experiments conducted at Winfield Lock and Dam, Winfield, WV.

DISCLAIMER: The contents of this report are not to be used for advertising, publication, or promotional purposes. Citation of trade names does not constitute an official endorsement or approval of the use of such commercial products. All product names and trademarks cited are the property of their respective owners. The findings of this report are not to be construed as an official Department of the Army position unless so designated by other authorized documents.

DESTROY THIS REPORT WHEN NO LONGER NEEDED. DO NOT RETURN IT TO THE ORIGINATOR.

Contents

Figures and Tables	v
Preface	ix
Unit Conversion Factors	xi
1 Introduction	1
2 Scaling Pulse Forces using Impulse Momentum Principles	6
2.1 Introduction.....	6
2.2 Non-site specific barge velocities.....	6
2.3 Barge train weight and mass.....	7
<i>Barge train weight</i>	7
<i>Tow weight</i>	8
<i>Barge train mass M</i>	8
2.4 Impulse momentum principle – general formulation.....	9
2.5 Initial, simplified Impact_Force formulation.....	11
2.6 Winfield Test Results.....	11
2.7 Response modification factor.....	12
2.8 Computing a pulse force time history using a scale factor applied to a unit pulse time history.....	13
3 Using Existing Time Histories	15
3.1 Introduction.....	15
3.2 Impact pulse time histories.....	15
3.3 Winfield prototype impact tests.....	15
3.4 Pittsburgh prototype impact tests.....	17
3.5 Unit pulse time histories.....	18
3.6 Adding frequency components to existing time histories.....	18
4 Engineering Methodology Used to Construct a Synthetic Pulse Force Time History	19
5 Visual Modeler GUI for Impact_Force	32
5.1 Introduction.....	32
5.2 Units and Barge Train tab.....	33
5.3 Time History tab.....	36
5.3.1 <i>Select Time History</i>	36
5.3.2 <i>Edit Time History</i>	40
5.4 Analyze tab.....	48
5.5 Zoom capability.....	54
6 Summary, Conclusions, and Recommendations	57
6.1 Summary and conclusions.....	57
6.2 Recommendations for future research.....	59

References.....	60
Appendix A: Summary Statistics for Winfield Prototype Impact Tests.....	61
Appendix B: Summary Statistics for Pittsburgh Prototype Impact Tests.....	77
Appendix C: Listing and Description of Impact_Force ASCII Input Data File (file name:Impact_Force.IN)	94
Report Documentation Page	

Figures and Tables

Figures

Figure 1.1. Barge train with initial contact velocity components V_{1-x} and V_{1-y} along the local barge axis at time t_1 of initial contact with the approach wall and with the barge train oriented at a constant approach angle θ to the wall's X_{Global} axis.....	1
Figure 1.2. Idealization of the barge train impact with the Winfield upstream flexible guide wall at impact time t (a), and the pulse for barge impact test 10 (b).....	4
Figure 2.1 Barge train initial contact velocity components V_{1-x} and V_{1-y} components along the local barge axis at time t_1 with the barge train oriented at a constant approach angle θ to the wall's X_{Global} axis.	10
Figure 3.1. Winfield Lock and Dam.	16
Figure 3.2. Barge with Load Cell Impact at Winfield.....	16
Figure 3.3. Cross-section of Winfield guide wall.....	17
Figure 4.1. First example of a synthetic pulse force time history created using Impact_Force.	20
Figure 4.2. Variation in Force values $F(t)$ normalized by the peak force F_{max} versus normalized times of time t divided by Δt_{peak} (i.e., Δt_{1R} in Figure 4.1 notation) by five relationships for Region 1.	22
Figure 4.3. Second example of a synthetic pulse force time history created using Impact_Force.....	25
Figure 4.4. Third example of a synthetic pulse force time history created using Impact_Force.	26
Figure 4.5. Fourth example of the five normalized pulse force time histories created using Impact_Force.	29
Figure 4.6. Fourth example of five pulse force time histories created using Impact_Force.	30
Figure 5.1. Introduction tab showing a force time-history plot and a barge impacting a flexible approach wall.	32
Figure 5.2. The Units and Barge Train tab.	33
Figure 5.3. Showing that the units to the right of the input text boxes change accordingly to the units selected from the table.	34
Figure 5.4. Modeling a 3-by-5 Barge Train.....	35
Figure 5.5. The Time History selection window.	36
Figure 5.6. Browsing for Unit Time-History data.....	37
Figure 5.7. Adding a Time History to the Comparison Window.	38
Figure 5.8. Changing the Currently Selected Time History.....	39
Figure 5.9. Create New Time History Dialog.....	39
Figure 5.10. The Time History Created from the Dialog in Figure 5.9.....	40
Figure 5.11. Editing the Selected Time-History Data.....	41
Figure 5.12. Sine Wave Pulse Dialog.....	42
Figure 5.13. Slope line from applying fade function.....	43

Figure 5.14. The Sine Wave Pulse History Before Combining with the Current Time History.	44
Figure 5.15. Using the “Add Values” Button to Sum the Sine Wave Pulses and the Winfield Test 10 data.	45
Figure 5.16. Trigonometry Based Pulse Dialog.	46
Figure 5.17. Trapezoid Pulse Dialog.	47
Figure 5.18. Analysis tab.	49
Figure 5.19. Finished analyzing data message box.	49
Figure 5.20. Plotting and Viewing Options Enabled.	50
Figure 5.21. Plot of Unit Time History.	51
Figure 5.22. View of Unit Time-History Plot File.	52
Figure 5.23. Save Barge Impact Plot Dialog.	52
Figure 5.24. Plot of Force Time History.	53
Figure 5.25. View of the Impact_Force.RUN file to locate F-Max.	54
Figure 5.26. Zoom of Fast Fourier Transform Plot.	55
Figure 5.27. Default Plot of Fast Fourier Transform.	56
Figure A.1. Winfield Lock and Dam.	61
Figure A.2. Barge and load cell impact at target.	62
Figure A.3. Animated barge impact plot with bit position.	62
Figure A.4. The beam cross section of the lock approach wall.	65
Figure A.5. displays all of the gage locations that were placed in the lock wall section.	65
Figure A.6. Connected Barge Train.	66
Figure A.7. A graphical representation of the target impact location of the lock wall.	68
Figure A.8. Force time history normal to the impact beam for Winfield Experiment 10.	69
Figure A.9. Frequency Domain Plot of Winfield Experiment 10.	69
Figure A.10. Force Time Histories normal to the impact beam for Experiments 5, 6, 7, 8, and 9.	70
Figure A.11. Force Time Histories normal to the impact beam for Experiments 10, 15, 16, 18, and 20.	71
Figure A.12. Force Time Histories normal to the impact beam for Experiments 11, 12, 13, 14, and 17.	71
Figure A.13. Force Time Histories normal to the impact beam for Experiments 19, 21, 22, and 23 conducted with a possum.	72
Figure A.14. The “possum” used between the barge train with load cell and the wall.	72
Figure B.1. Load cell forces F10, F11, and the interpreted force normal to the wall Fw for Experiment 30 (from Arroyo et al. 2003).	78
Figure B.2. Load cell forces F10, F11 and the interpreted force normal to the wall Fw for Experiment 29 (from Arroyo et al. 2003).	79
Figure B.3. 1 Load cell force F11, Strain Gage S2 and their ratio for Experiment 29.	80
Figure B.4. Lateral Strain Gage SY1 (Channel 12) time history in the transverse direction on the deck plate for Experiment 8.	81
Figure B.5. Fourier Transformation of the Lateral Strain Gage SY1 (Channel 12) time history in the transverse direction on the deck plate for Experiment 8.	82

Figure B.6. Lateral Strain Gage SY1 (Channel 12) time history in the transverse direction on the deck plate for Experiment 8.	83
Figure B.7. Fourier transformation of the Lateral Strain Gage SY1 (Channel 12) time history in the transverse direction on the deck plate for Experiment 24.	84
Figure B.8 Lateral Strain Gage SY1 (Channel 12) time histories in the transverse direction on the deck plate for Experiments 8, 9, 11, 12, 13, and 14.	85
Figure B.9. Lateral Strain Gage SY1 (Channel 12) time histories in the transverse direction on the deck plate for Experiments 8, 15, 16, 17, 18, 19, and 20.	86
Figure B.10. Lateral Strain Gage SY1 (Channel 12) time histories in the transverse direction on the deck plate for Experiments 8, 21, 22, 23, 24, and 25.	87
Figure C.1. Barge train with initial contact velocity components $V_{1-x-local}$ and $V_{1-y-local}$ along the local barge axis at time t_1 of initial contact with the approach wall and with the barge train oriented at a constant approach angle θ to the wall's X_{Global} axis.	94
Figure C.2. Example of a force time history with 3 pulses created using Impact_Force.	97
Figure C.3. Example of user provided fractional maximum amplitudes FR_i for a force time history with 3 pulses.	98
Figure C.4. Example of user provided fractional maximum amplitudes FR for the trapezoidal rise portion of pulse i	100
Figure C.5. Example of user provided fractional maximum amplitudes FR for the trapezoidal fall portion of pulse i	102

Tables

Table 2.1. Ranges in non-site specific approach angles and approach velocities, expressed in local barge coordinates for preliminary analyses.	6
Table 2.2. Typical Characteristics of Barges on the Inland Waterway System	7
Table 4.1. First example of a user specified force time history consisting of 4 pulses with the maximum amplitude for pulses 2, 3, and 4 normalized by the maximum amplitude of pulse 1.	20
Table 4.2. Force values $F(t)$ normalized by the peak force F_{max} at normalized times of t divided by Δt_{peak} for five relationships for Region 1.	22
Table 4.3. Mathematical definitions of the trigonometric pulse shapes used by the PC-based program Impact_Force and its solution procedure.	23
Table 4.4. Second example of a user specified single pulse shape and relative magnitude for the pulse.	25
Table 4.5. Third example of a user specified force time history consisting of 3 pulses with the maximum amplitude for pulses 2 and 3 normalized by the maximum amplitude of pulse 1.	26
Table 4.6. Fourth example of five user specified synthetic force time histories consisting of 4 pulses each and all with the same normalized maximum amplitudes.	28
Table 4.7. Resulting areas under each of the five unit pulse force time histories of the fourth example.	29
Table 4.8. Resulting maximum amplitudes for each of the five user specified force time histories of the fourth example.	30
Table A.1. The angles and computed velocity, peak forces, and duration of impacts.	64

Table A.2. Individual barge and tow information.....	66
Table A.3. Barge impact location of the lock wall.....	67
Table A.4. Data used to compute Response Modification Factor (RMF) Part I.....	74
Table A.5. Data used to compute Response Modification Factor (RMF) Part II.....	75
Table A.6. Data used to compute Response Modification Factor (RMF) Part III.....	75
Table A.7. Average RMF of all experiments, experiments performed without a possum, and experiments performed with a possum.....	76
Table A.8. Standard Deviation RMF of all experiments, experiments performed without a possum, and experiments performed with a possum.....	76
Table A.9. Coefficient of Variation RMF of all experiments, experiments performed without a possum, and experiments performed with a possum.....	76
Table B.1 Summary of the number of pulses recorded in Lateral Strain Gage SY1 (Channel 12) for eighteen barge impact experiments.....	82
Table B.2. Summary Data for Lateral Strain Gage SY1 (Channel 12) Maximum Compression Strain in Each of 5 Pulses Normalized by the Peak Strain in the First Pulse for the Transverse Deck Plate Strain.....	88
Table B.3. Summary Statistics for Lateral Strain Gage SY1 (Channel 12) Maximum Compression Strain in Each of 5 Pulses Normalized by the Peak Strain in the First Pulse for the Transverse Deck Plate Strain.....	88
Table B.4. Summary of duration of impact, time to peak transverse deck plate strain and the duration of each strain pulse (for up to five pulses).....	89
Table B.5.a. Summary Statistics for Lateral Strain Gage SY1 (Channel 12) time to Maximum Compression Strain and duration of each pulse of Transverse Deck Plate Strain.....	90
Table B.5.b. Summary Statistics for Lateral Strain Gage SY1 (Channel 12) duration of total contact with the wall during primary impact pulses.....	90
Table B.6.a. Summary of duration of impact, time to peak transverse deck plate strain and the natural frequencies by Fourier Transformation.....	91
Table B.6.b. Summary of duration of impact, time to peak transverse deck plate strain and the inverse of natural frequencies (from Fourier Transformation).....	91
Table B.7.a. Summary of duration of impact, time to peak transverse deck plate strain and two times the duration of each strain pulse (for up to five pulses).....	92
Table B.7.b. Summary of duration of impact, time to peak transverse deck plate strain and the inverse of the product of two times the duration of each strain pulse (for up to five pulses).....	93
Table C.1. Specification of Units.....	95

Preface

To conduct a dynamic structural response analysis of flexible approach walls at Corps locks using structural dynamics engineering computer programs, a force time history is needed to represent the impact of a barge train with the approach wall. This technical report describes an engineering methodology used to create this pulse force time history normal to the wall. This engineering methodology is implemented in a PC-based FORTRAN program and Visual Modeler named Impact_Force, which is also discussed in this report. The engineering formulation for Impact_Force uses existing pulse data or synthetic pulse data and the impulse momentum principle to convert the linear momentum of a barge train into a pulse force time history acting normal to the approach wall. Included in this effort is the interpretation of the results from the 1997 full-scale barge train impact prototype experiments conducted at Old Lock and Dam 2 just north of Pittsburgh, PA, and of the 2008 full-scale barge impact experiments conducted at Winfield Lock and Dam, Winfield, WV. Funding for this research, including software development, was provided by the Navigation Systems Research Program. The research was performed under Work Unit J4J37B, entitled "Vessel/Barge Impact" for which Dr. Robert M. Ebeling, Engineering Informatics Systems Division (EISD), Information Technology Laboratory (ITL), U.S. Army Engineer Research and Development Center (ERDC), Vicksburg, MS, was the Principal Investigator. Technical Monitor was Anjana Chudgar, Headquarters, U.S. Army Corps of Engineers (HQUSACE).

James Clausner, formerly of the Coastal and Hydraulics Laboratory (CHL), ERDC, Vicksburg, MS, was the Navigation Systems Research Program Manager at the time of the research. Dr. John Hite, CHL, was the Inland Focus Area Leader; and Eddie Wiggins, CHL, was the Navigations Systems Research Program Manager at the time of publication. Jeff Lillycrop, CHL, was the Technical Director for Navigation. James E. Walker was the Navigation Business Line Leader, HQUSACE.

Dr. Ebeling was author of the scope of work for this research. The report was prepared by Dr. Ebeling, Barry White, Abdul Mohamed, and Bruce C. Barker, under the supervision of Dr. Robert M. Wallace, Chief, EISD, ITL; and Dr. Reed Mosher, Director, ITL.

COL Gary E. Johnston was Commander and Executive Director of ERDC.
Dr. Jeffery P. Holland was Director.

Unit Conversion Factors

Multiply	By	To Obtain
feet	0.3048	meters
inches	0.0254	meters
knots	0.5144444	meters per second
miles (nautical)	1,852	meters
miles (U.S. statute)	1,609.347	meters
miles per hour	0.44704	meters per second
pounds (force)	4.448222	newtons
pounds (mass)	0.45359237	kilograms
slugs	14.59390	kilograms
tons (force)	8,896.443	newtons
tons (force) per square foot	95.76052	kilopascals
tons (long) per cubic yard	1,328.939	kilograms per cubic meter
tons (2,000 pounds, mass)	907.1847	kilograms
tons (2,000 pounds, mass) per square foot	9,764.856	kilograms per square meter
tons (force)	2	kip
kip	1,000	pounds

1 Introduction

To conduct a dynamic structural response analysis of approach walls at Corps locks using structural dynamics engineering computer programs, a force time history is needed to represent the impact of a barge train with the approach wall. This impact event is idealized in Figure 1.1, where $F_{\text{normal-wall}}(t)$ denotes the pulse force time history that is used in the dynamic structural analysis. This technical report describes an engineering methodology used to create this pulse force time history normal to the wall. This engineering methodology is implemented in a PC-based FORTRAN program and respective visual modeler named Impact_Force. The Figure 1.1 pulse force time history $F_{\text{normal-wall}}(t)$ is the reaction of the approach wall on to the barge train during the impact event. Note that the force $F_{\text{normal-wall}}(t)$ is normal to the face of the approach wall. The engineering formulation for Impact_Force uses existing pulse data or synthetic pulse data and the impulse momentum principle to convert the linear momentum of a barge train into a pulse force time history acting normal to the approach wall.

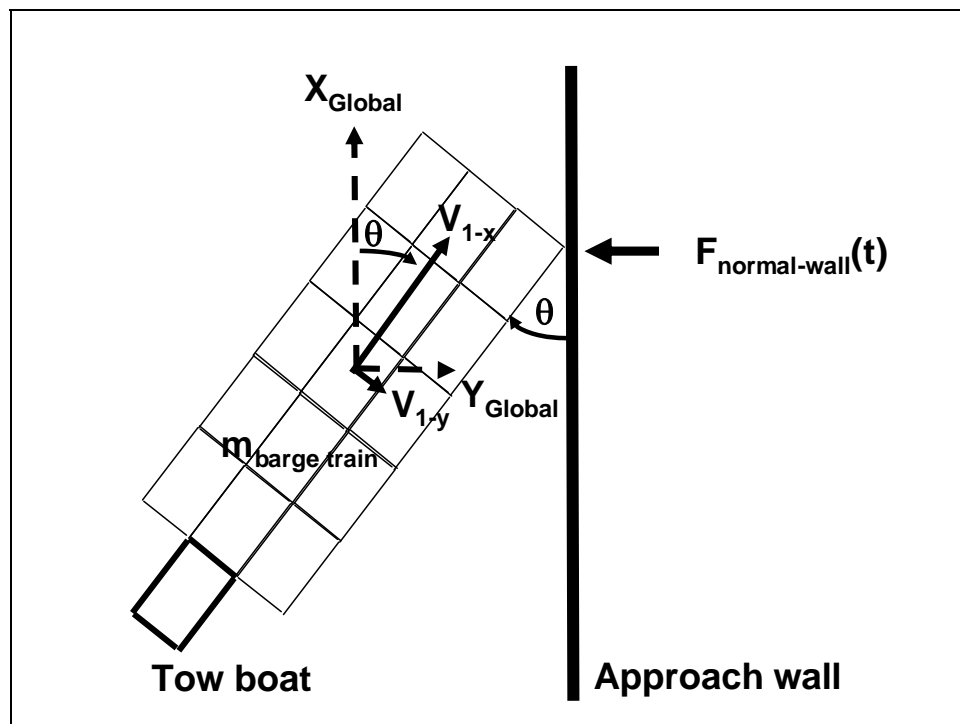

Figure 1.1. Barge train with initial contact velocity components V_{1-x} and V_{1-y} along the local barge axis at time t_1 of initial contact with the approach wall and with the barge train oriented at a constant approach angle θ to the wall's X_{Global} axis.

The engineering formulation developed for and described in this report assumes that the District engineer will have knowledge of

1. the size of the barge train (e.g., 3-by-5 for Figure 1.1)
2. the average weight of an individual barge
3. the weight of the tow
4. hydrodynamic added mass factors (recommendations provided in this report)
5. the barge approach velocities (often expressed in local barge coordinates) and
6. approach angle (the angle measured from the face of the wall to the side of the barge train),

for the usual, unusual and extreme load cases. Figure 1.1 shows that the global X-, Y-axis is oriented parallel to and perpendicular to the approach wall, respectively. It also shows that the local x-, y-axis is oriented parallel to and perpendicular to the longitudinal axis of the barge train.

Given an impact pulse force time history normal to the wall, $F_{\text{normal-wall}}(t)$, and assuming no other forces according to the conservation of momentum, we know that

$$m_{\text{barge train-normal}} \cdot (V_{1\text{-normal}}) = \int_{t_1}^{t_2} F_{\text{normal-wall}}(t) \cdot dt \quad (1.1)$$

From this formulation we can determine how to scale a unit force pulse history, either from existing records or synthetically created unit pulse time histories.¹

Chapter 2 summarizes how the barge train's linear impulse is calculated, and how this impulse is used to scale the user selected unit pulse time history.

Chapter 3 discusses the use of existing pulse force time histories recorded during the full-scale barge impact experiments conducted at Winfield Lock and Dam (Barker et al., in press) and the Pittsburgh Prototype tests (Patev

¹ A unit pulse force time history is one in which a force versus time relationship is only a few seconds in duration (i.e., a pulse) and is scaled to a maximum amplitude force of unity (in the force units appropriate for the problem).

et al. 2003b), the setup and limitations of each full-scale impact field test. There is also a brief discussion of a method to alter, i.e., enhance, the time-history pulse data recorded during these full-scale barge train impact tests with specific frequency information as well as the identification of the harmonics inherent to the time history.

Chapter 4 describes the construction of artificial pulse force time histories. There is a discussion of when and why artificial time histories should be constructed. There is also a discussion of the different methods of constructing pulses and their effects.

Chapter 5 is a user's guide to the visual modeler for Impact_Force. Sample problems are used to highlight the features and limitations of the program.

Chapter 6 presents the conclusions of this report and recommendations for further research.

Appendix A summarizes the results of an extensive and detailed interpretation of data recorded by Barker et al. (in press) during full-scale barge impact tests conducted at Winfield, WV. Nineteen out of 23 full-scale impact experiments conducted using a ballasted (with anthracite coal) 3-by-3 barge train pushed by tow were interpreted in this appendix. An instrumented load cell bumper system was mounted on the impact corner of the lead barge that impacted the approach wall during the experiments. The load cells recorded the pulse force time histories resulting from the impact event. This pulse force time-history data was interpreted in this appendix so as to assist in the development of the form and shape of the Figure 1.2 pulse force time history $F_{\text{normal-wall}}(t)$. This pulse force time-history data was also used to derive the response modification factor (RMF) used in the impulse momentum principle that is used to scale pulses for different impact velocities, approach angles and impacts involving different size barge trains. The RMF will be discussed in Chapter 2.

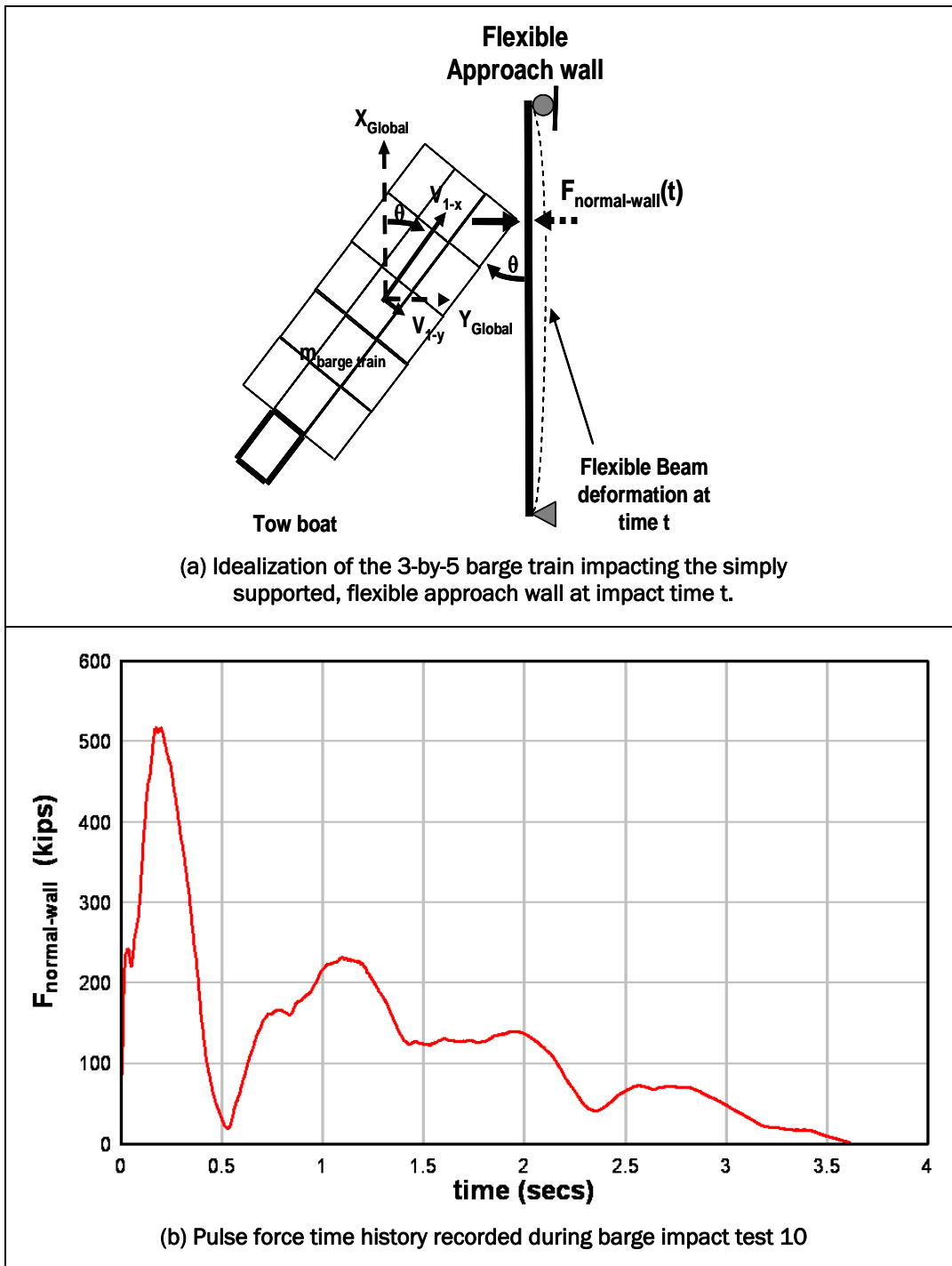

Figure 1.2. Idealization of the barge train impact with the Winfield upstream flexible guide wall at impact time t (a), and the pulse for barge impact test 10 (b).

Appendix B summarizes the results of an extensive and detailed interpretation of data recorded by Patev et al. (2003b) during the prototype tests conducted at Old Lock and Dam 2 just north of Pittsburgh, PA. Seventeen out of a series of 36 full-scale impact experiments conducted using a ballasted 2-by-2 barge train pushed by tow were interpreted in this appendix. Strain gages were mounted on the barge impact corner deck plate which recorded the strain time histories in the deck plate during impact with the old lock wall. The strain gage time-history data recorded in the transverse direction, was interpreted in this appendix so as to assist in the development of the form and shape of the pulse force time history $F_{\text{normal-wall}}(t)$.

Appendix C describes the ASCII data file to the PC-based FORTRAN program Impact_Force which performs the engineering evaluation and generates the force time history for impacts with approach walls at Corps locks. This ASCII input file is created by a Visual Modeler.

2 Scaling Pulse Forces using Impulse Momentum Principles

2.1 Introduction

The engineering formulation for Impact_Force uses existing pulse data or synthetic pulse data and the impulse momentum principle to convert the linear momentum of a barge train into a pulse force time history acting normal to the approach wall for any size barge train, any approach velocity, and any approach angle. This chapter discusses the various relationships used in this engineering methodology. Recall that the three basic entities needed by the District Engineer are the barge train approach velocity, mass and approach angle. The barge train mass is determined by summing the (average) weights of the barges and the weight of the tow boat.

2.2 Non-site specific barge velocities

Early in the project design phase approach velocity study projections may not be available. Preliminary analyses may be conducted using the data contained in Table 2.1. These data provide ranges in non-site specific general guidance on approach angles and approach velocities (from Tables B-3 and B-4 of ETL 1110-2-563 [Headquarters, Department of the Army, 2004]).

Table 2.1. Ranges in non-site specific approach angles and approach velocities, expressed in local barge coordinates for preliminary analyses.

Load Condition	Approach Angle θ (degrees)	Forward Velocity V_x (fps)	Lateral Velocity V_y (fps)
Usual	5-10	0.5-2.0	0.01-0.1
Unusual	10-20	3.0-4.0	0.4-0.5
Extreme	20-35	4.0-6.0	>1.0

Note that the Table 2.1 velocities are in the local (barge) x-, y-axis as shown in Figure 1.1.

2.3 Barge train weight and mass

Barge train weight

The barge weight is based on the total weight of the barge and the commodity being carried in the barge hopper. Weights for inland waterway barges are generally expressed in short tons (2,000 lb per ton). ETL 1110-2-563 observes that a loaded jumbo open hopper barge drafting 9 ft (3 m) typically weighs between 1,500 to 1,900 tons (680 to 862 kg), and typical weight of an empty barge is 200 to 270 tons (91 to 122 kg).

Additional information regarding barge weights can be obtained from Table 5.5.1-1 of American Association of State Highway and Transportation Officials (AASHTO) Guide Specification and Commentary for Vessel Collision Design of Highway Bridges, Volume 1: Final Report, February 1991 (AASHTO 1991). Table 2.2 contains information on barge capacity (weight of cargo) and tare weight (weight of empty barge).

Table 2.2. Typical characteristics of barges on the Inland Waterway System (from Table 5.5.1-1 of AASHTO (1991)).

Barge Type	Size	% of Barges in System 1975	Length (feet)	Width (feet)	Maximum Loaded Draft (feet)	Capacity (Tons)	Tare of Barge (Tons)
Open Hopper	Small	6	120	30	7	630	
Open Hopper	Standard	14	175	26	9	1060	
Open Hopper	Jumbo	27	195	35	9	1700	200
Open Hopper	Oversize	1	245	35	10	2400	
Covered Hopper	Jumbo	22	195	35	9	1700	
Deck Barge	Small	10	100/150	26/32	6	350/ 600	
Deck Barge	Jumbo	2	195	35	9	1700	
Deck Barge	Oversize	2	200	50	9	2050	
Tank Barge	Small	3	135	40	9	1300	
Tank Barge	Jumbo	4	195	35	9	1700	
Tank Barge	Oversize	9	185 /290	53	9	2530/ 3740	600

Tow weight

In addition to barge train weight, the weight of the tow boat should also be included in the calculation of the total barge train weight. Note that in the full-scale instrumented impact tests conducted in 1998 at Old Gallipolis/ Robert C. Byrd lock (Patev et al. 2003a), the towboat used for the 3-by-5 barge train weighs 550 tons (Table A-4 in Arroyo et al. 2003). And in the case of the full-scale instrumented impact tests conducted in 2008 at Winfield lock (Barker et al., in press), the towboat used for the 3-by-3 barge train weighs 507 tons.

Barge train mass M

The mass is based on the total weight of the barge and the commodity being carried in the barge hopper. The barge train mass M (kip-sec²/ft) is determined by dividing the sum of the individual barge weights (kips) by the gravitational constant g (32.174 ft/sec²). The equations for total mass (barge train mass M + tow mass + hydrodynamic added mass) with respect to the Global (wall) axis (shown in Figure 1.1) are

$$m_{\text{barge train-normal}} = \frac{m_{\text{barge train-x}} \cdot m_{\text{barge train-y}}}{m_{\text{barge train-x}} \cdot \cos^2(\theta) + m_{\text{barge train-y}} \cdot \sin^2(\theta)} \quad (2.1)$$

$$m_{\text{barge train-parallel}} = \frac{m_{\text{barge train-x}} \cdot m_{\text{barge train-y}}}{m_{\text{barge train-x}} \cdot \sin^2(\theta) + m_{\text{barge train-y}} \cdot \cos^2(\theta)} \quad (2.2)$$

The mass terms of $m_{\text{barge-train-x}}$ and $m_{\text{barge-train-y}}$ are first defined in the local barge x-, y-axis coordinates using the procedure given in ETL 1110-2-338 (Headquarters, Department of the Army (1993)),

$$m_{\text{barge train-x}} = 1.05 \cdot (\text{barge train mass M} + \text{tow mass}) \quad (2.3)$$

$$m_{\text{barge train-y}} = 1.4 \cdot (\text{barge train mass M} + \text{tow mass}) \quad (2.4)$$

The constants of 1.05 and 1.4 are a simplified approximation of the hydrodynamic added mass in the longitudinal and transverse barge train local x-, y-axis directions, respectively. The results from Equations 2.3 and 2.4, along with the approach angle θ are substituted into Equation 2.1 to obtain the total mass normal to the wall, $m_{\text{barge train-normal}}$.

2.4 Impulse momentum principle – general formulation

Fundamental to the engineering formulation used to develop the pulse force time history is the impulse momentum principle, which may be expressed normal to the wall as

$$m_{\text{barge train-normal}} \cdot (V_{2\text{-normal}} - V_{1\text{-normal}}) = \int_{t_1}^{t_2} F(t) \cdot dt \quad (2.5)$$

where:

$m_{\text{barge train-normal}}$ = total mass of the barge train (barge train mass M + tow mass + hydrodynamic added mass) normal to the approach wall.

$V_{1\text{-normal}}$ = velocity at initial contact (at time t_1) of the barge with the approach wall and is the velocity component normal to the wall, acting along the Figure 2.1 Y_{Global} axis.

$V_{2\text{-normal}}$ = velocity at the end of contact (at time t_2) of the barge train with the approach wall and is the velocity component normal to the wall (acting along the Y_{Global} axis).

$F(t)$ = all of the forces acting on the barge train and in the direction normal to the approach wall, including the reaction force of wall during barge train impact [designated $F_{\text{normal-wall}}(t)$ in Figure 2.1].

At time t_1 the barge train resultant approach velocity V_1 (acting at an angle β referenced to the Figure 2.1 local barge x -, y -axis) is given by

$$V_1 = \sqrt{(V_{1-x})^2 + (V_{1-y})^2} \quad (2.6)$$

with the angle β given by the relationship

$$\tan(\beta) = \frac{V_y}{V_x} \quad (2.7)$$

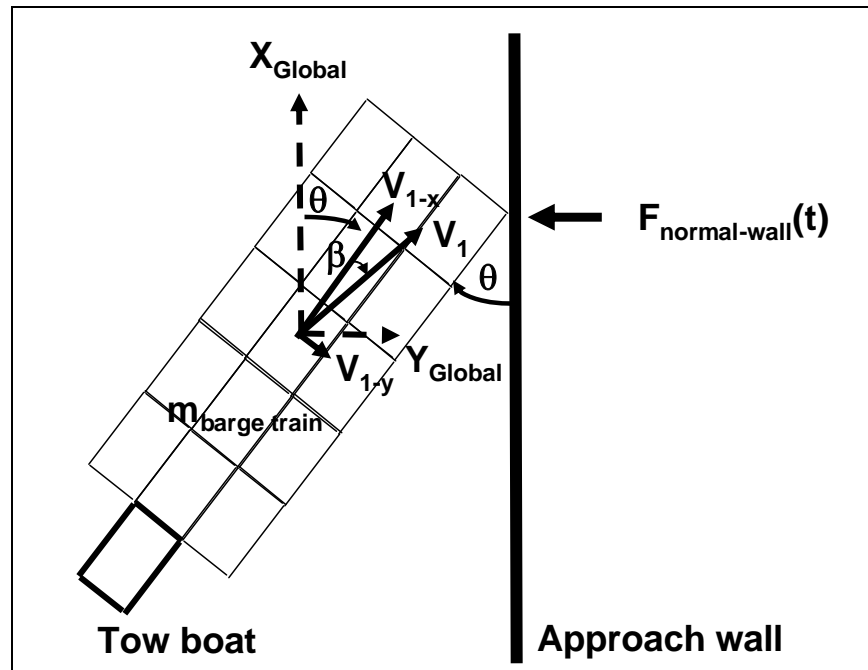

Figure 2.1 Barge train initial contact velocity components V_{1-x} and V_{1-y} components along the local barge axis at time t_1 with the barge train oriented at a constant approach angle θ to the wall's X_{Global} axis.

Note that β is measured from the X -global (wall) axis as shown in Figure 2.1. The velocity component normal to the wall (i.e., along the Y_{Global} axis) given by

$$V_{1\text{-normal}} = V_1 \cdot \sin(\theta + \beta) \quad (2.8)$$

and the velocity component parallel to the wall (i.e., along the X_{Global} axis) given by

$$V_{1\text{-parallel}} = V_1 \cdot \cos(\theta + \beta) \quad (2.9)$$

Equivalently, the velocity component normal to the wall is given by

$$V_{1\text{-normal}} = V_{1-x} \cdot \sin(\theta) + V_{1-y} \cdot \cos(\theta) \quad (2.10)$$

and the velocity component parallel to the wall is given by

$$V_{1\text{-parallel}} = V_{1-x} \cdot \cos(\theta) - V_{1-y} \cdot \sin(\theta) \quad (2.11)$$

2.5 Initial, simplified Impact_Force formulation

The key assumptions for the simplified, initial engineering formulation implemented in Impact_Force are,

- the impulse momentum principle of Equation 2.5, which is expressed in a direction normal to the wall, describes the impact problem,
- all forces acting on the barge train (in the direction normal to the wall), except the wall's reaction force $F_{\text{normal-wall}}(t)$ during impact (from time t_1 to t_2) such as a drag force (may not be an impulsive force) , and
- at the end of contact, time t_2 , the velocity normal to the wall $V_{2\text{-normal}}$ is assumed to be small and is set equal to zero.

It is rationalized that by only considering the reaction force between the barge train and the beam [i.e., $F_{\text{normal-wall}}(t)$] in the impulse linear momentum relationship and assuming the $V_{2\text{-normal}}$ at the end of contact is zero for the barge impact problem results in a conservative estimate for the wall's reaction force $F_{\text{normal-wall}}(t)$ during impact. For these assumptions and considering the Figure 2.1 vector directions, $F(t)$ is set equal to $-F_{\text{normal-wall}}(t)$, Equation 2.5 becomes

$$m_{\text{barge train-normal}} \cdot (V_{1\text{-normal}}) = \int_{t_1}^{t_2} F_{\text{normal-wall}}(t) \cdot dt \quad (2.12)$$

This initial formulation assumes the entire normal component of the linear momentum of the approaching barge train is balanced by the impulse force time history of the wall acting on the barge train and in the direction normal to the wall. This is a conservative formulation because the momentum is resisted solely by the reaction impulse force time history the wall provides to the barge during impact, in the direction normal to the wall.

2.6 Winfield Test Results

The August 2008 full-scale instrumented impact tests conducted by Barker et al. (in press) at Winfield lock involving 23 impact tests between a 3-by-3 barge train ballasted with anthracite coal and a simply supported, long-span precast impact beam allows for an evaluation of the conservativeness of the simplified Equation 2.12 relationship. Values for all parameters listed in the left side and right side of Equation 2.12 were measured

during these impact tests. Appendix A summarizes the computations: This evaluation concluded that the linear momentum normal to the wall (the left side term of Equation 2.12) exceeds the Impulse (i.e., the right side term of Equation 2.12) for all of the individual impact tests evaluated. A reduction factor needs to be applied to the Impulse in Equation 2.12 to allow the magnitude of the Impulse force time history (normal to the impact wall) to be equal to the magnitude of the Linear Momentum (normal to the wall) for the Winfield recorded test data. This Appendix A impact data evaluation provides the opportunity to propose a value for this constant that multiplies the (left-hand side) Linear Momentum term, as discussed in the next section.

2.7 Response modification factor

If the specified terms that make up the momentum term on the left side of Equation 2.12 are not equivalent to the impulse term on the right side of the equation then an appropriate response modification factor can be calculated to account for the imbalance. With the available 2008 Winfield field data now available, it is possible to moderate too-conservative Equation 2.12 estimates with a constant response modification factor, RMF. Actual resulting impulse force time-history data can be compared to computed results to determine a scale factor representative for the actual test case without extensive research into the reasons why this modification is needed. A response modification factor must be applied with care to avoid excessive conservatism.

Equation 2.12 provides the clue for determining the response modification factor. For the 2008 Winfield data, when the momentum of the barge train, determined by its mass and velocity (normal to the wall) per the left side of the equation, is not equivalent to the integral of the force time history (normal to the wall) then its likely that there are other outside forces affecting the momentum of the barge train. These outside forces can be accounted for by a scale factor applied to the momentum of the barge train, i.e., a response modification factor.

$$m_{\text{barge train-normal}} \cdot (V_{1\text{-normal}}) \cdot \text{RMF} = \int_{t_1}^{t_2} F_{\text{normal-wall}}(t) \cdot dt \quad (2.13)$$

$$\text{Impulse} = \int_{t_1}^{t_2} F_{\text{normal-wall}}(t) \cdot dt \quad (2.14)$$

$$\text{Momentum} = m_{\text{barge train-normal}} \cdot (V_{1\text{-normal}}) \quad (2.15)$$

$$\text{RMF} = \frac{\text{Impulse}}{\text{Momentum}} \quad (2.16)$$

It is important to determine an appropriate response modification factor for the location involved. Calculations in Appendix A for the 2008 Winfield full-scale test data indicates a mean (μ), standard deviation (σ) and coefficient of variation (COV) for the RMF value of $\mu = 0.397$, $\sigma = 0.047$, and $\text{COV} = 0.118$, respectively. Should the user specify a RMF equal to 1.0, the Winfield data would infer that this would result in a conservative impulse time history. Appendix A provides a table that shows all the variables that were used to compute the RMF for each test.

The recorded values for the local barge-x velocity (V_x) and approach angle (θ) were provided by Barker et al. (in press).

2.8 Computing a pulse force time history using a scale factor applied to a unit pulse time history

Recall that the Equation 2.12 impulse-linear momentum principle normal to the approach wall is used to define this problem; with the two terms of mass and velocity (i.e., the linear momentum of Equation 2.15) defined by the engineer's data input. After the engineer selects a pulse shape and form via the selection of a normalized pulse force time history (or creates their own unit pulse shape and form as discussed in Chapter 4), Equation 2.12 is solved numerically by the PC-program Impact_Force in two computational steps:

$$\text{Unit_Area} = \int_{t_1}^{t_2} \text{FR}(t) \cdot dt \quad (2.17)$$

with $\text{FR}(t)$ representing the normalized force time history (i.e., with a maximum force of unity within the time history). The maximum amplitude for the first pulse in the time history, F_{max} , is computed using

$$F_{\max} = \frac{\text{RMF} \cdot m_{\text{barge train-normal}} \cdot (V_{1\text{-normal}})}{\text{Unit_Area}} \quad (2.18)$$

The resulting pulse force time history normal to the wall, $F_{\text{normal-wall}}(t)$, is

$$F_{\text{normal-wall}}(t) = F_{\max} \cdot \text{FR}(t) \quad (2.19)$$

This pulse force time history, $F_{\text{normal-wall}}(t)$, satisfies Equation 2.13. This is the pulse force time history to be used in the dynamic structural analysis of flexible/deformable approach walls. It is provided as an ASCII output file by `Impact_Force`.

3 Using Existing Time Histories

3.1 Introduction

While there are provisions in the Impact_Force suite of programs to build time histories, it is much preferred that existing time histories be used. This chapter, as well as Appendix A and Appendix B, will explain some sources of time histories and how they were gathered, and provide guidance for their usage in Impact_Force.

3.2 Impact pulse time histories

Impact pulse time histories have been gathered from full-scale tests at Winfield and Pittsburgh. It is envisioned that in the future, this impact pulse time-history data base will be enhanced by additional full-scale impact test data. This pulse time-history data may take the form of impact force time-history data, like the data recorded at Winfield, or it may take the form of pulse time-history data recorded by strain gages mounted (in the transverse direction) on barge deck plate, like the Pittsburgh data.

3.3 Winfield prototype impact tests

This is a summary of the Winfield data found in Appendix A. The Winfield data was collected at the Winfield Lock and Dam in Red House, WV (Figure 3.1). The tests were performed in August 2008. Twenty-three impact tests by a 3-by-3 barge train ballasted with anthracite coal, were run to gather force time-history data, with impacts against a flexible approach lock wall (Figure 3.2). The guide wall is a precast, prestressed hollow beam (i.e., flexible structure) with a length of 117 feet 7 3/4 inches. A cross-section of the hollow beam is shown in Figure 3.3. It is simply supported on both ends (i.e., with no constraint against rotation at either end) and acts like a flexible structure which will deflect upon impact as shown by the deflection data recorded during these 23 full-scale impact tests discussed in Barker et al. (in press).

This full-scale impact test conducted at Winfield is the first involving impacts with the next-generation of Corps flexible approach wall structures.



Figure 3.1. Winfield Lock and Dam.



Figure 3.2. Barge with Load Cell Impact at Winfield.

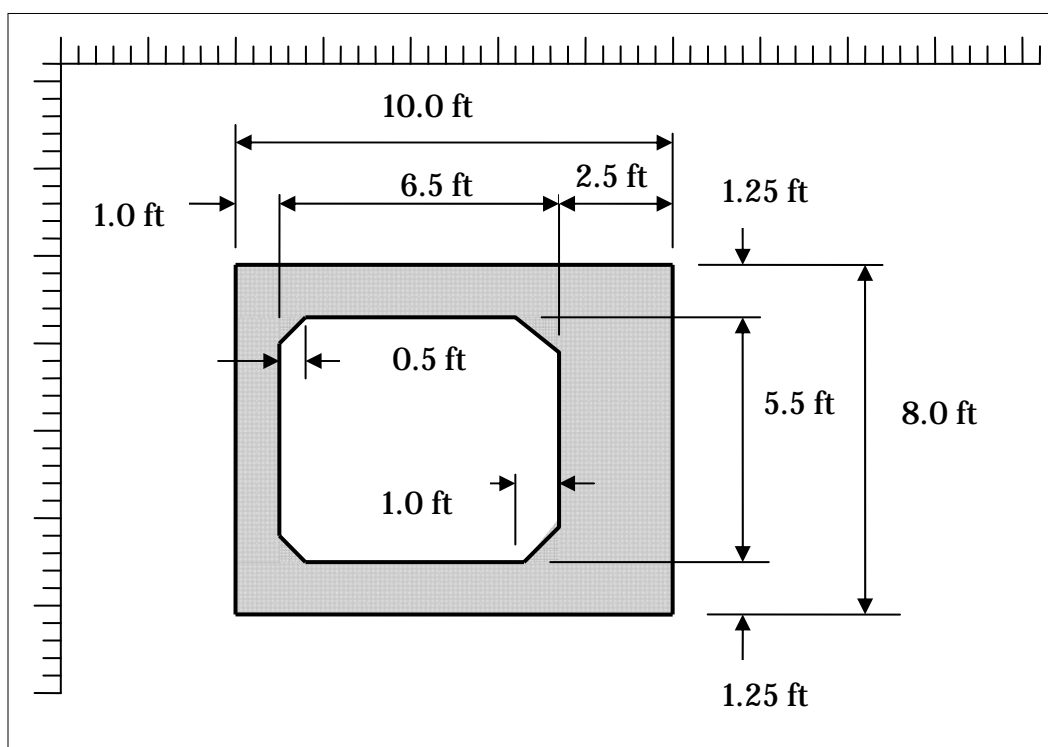

Figure 3.3. Cross-section of Winfield guide wall.

Some tests were performed with a “possum” acting as a “shock absorber.” The possum is a knotted rope with a nylon mesh surrounding it. A deck-hand would drop the possum to be between the impact point of the barge with the wall. These tests resulted in a delayed time to peak force. According to Barker et al. (in press), the peak force in the time history is reduced but the impulse was preserved.

It is recommended that this data be used in situations where a flexible wall is being analyzed. Comparisons between these tests and Pittsburgh tests indicate that in impacts with flexible walls, the barge train does not lose contact with the structure through-out the time history. Selection of impact tests should also take into consideration the impact angle of the test (found in Table A.1).

3.4 Pittsburgh prototype impact tests

This is a summary of the Pittsburgh data found in Appendix B. The Pittsburgh data was recorded in August of 1997 at the Old Lock and Dam 2 just north of Pittsburgh, PA. The experiments were performed with a 2-by-2 fully ballasted barge train impacting a stiff-to-rigid wall. The data used in this report were collected with strain gages mounted on the deck plate and

oriented along the transverse axis of the impact barge. Section B.1.1 of Appendix B discusses the interpretation of strain time histories with respect to force time histories. Given the similarity of strain to force measurements performed at Gallipolis, scaled by a fairly consistent factor, it seems sensible to substitute normalized strain time-history data for normalized force time-history data in the absence of force time-history data, as was the case at Pittsburgh.

The nature of Pittsburgh data is different from the Winfield data because of the number of barges and the stiff-to-rigid wall. The data still exhibits pulses, but the strain returns to zero between each pulse. The number of pulses varies from three to five, with fewer pulses occurring more often.

3.5 Unit pulse time histories

The results of the Winfield and Pittsburgh test have been scaled to where the maximum peak is of unit height. This scale factor was determined for each data set and applied to all the data in that set. In this way, the data can be scaled by momentum of the barge train, as in Equation 2.19.

3.6 Adding frequency components to existing time histories

In some situations, it would be advantageous to modify existing time histories to discover the effects of resonance in a flexible wall or beam. For these situations, the Impact_Force suite of programs provides methods for adding frequency components to a time history. These frequency components are added using sine waves specified with amplitude and frequency. The amplitude is measured in the appropriate force units. The frequency is specified either by inputting period, radians per second, or frequency directly.

Multiple frequency components can be combined to create new waveforms using Fourier synthesis, but in most cases, sine waves will be adequate to determine how a structure will perform under resonance.

After the time history has been modified by adding the frequency components, negative values for force are removed, to reflect that there are no tensile forces against the barge train. Then the resulting time history is scaled for unit height so that the data can be scaled by momentum of the barge train, as in Equation 2.19.

4 Engineering Methodology Used to Construct a Synthetic Pulse Force Time History

Seven items are specified as input to the PC-based program Impact_Force. These are:

1. the approach angle θ ,
2. the approach velocity in local x,y barge coordinates (V_{1-x}, V_{1-y}) at time of initial contact t_1 (the program computes $V_{1-normal}$),
3. the total barge train weight and the tow weight (the program computes the barge train mass in local x,y barge coordinates, $m_{barge\ train-x}$ and $m_{barge\ train-y}$,
4. the hydrodynamic added mass factors in the in the longitudinal and transverse local x,y barge axis directions (e.g., 1.05 and 1.4, respectively),
5. the duration of contact for the barge train with the wall, $\Delta t_{duration}$ ($= t_2 - t_1$),
6. the time Δt_{peak} after initial contact (i.e., after t_1) to the peak force, designated as F_{max} , in the pulse force time history, and
7. features relating to the shape of the force time history; the number of individual pulses; the time duration of each of the individual pulses (including zero force quiet time); and the amplitude of the individual pulses relative to the amplitude of the peak for the initial pulse (i.e., relative to Figure 4.1 F_{max}).

The first four items have been discussed previously and are depicted in Figure 4.1. These items define the terms contained on the left-hand side of Equation 2.12. The right-hand side of Equation 2.12 represents the area contained within the force time history. To “define” the right-hand side force time history, additional information is required. This information is associated with items five through seven.

Items five through seven are depicted in Figure 4.1 for the example of a synthetic force time history consisting of four separate pulses with no quiet time (i.e., no zero force) regions between the individual pulses. The Figure 4.1 maximum amplitudes for the four individual pulses are listed in Table 4.1 and expressed as the maximum force amplitude relative to the amplitude of pulse 1 (designated F_{max}). Each of the four pulses has

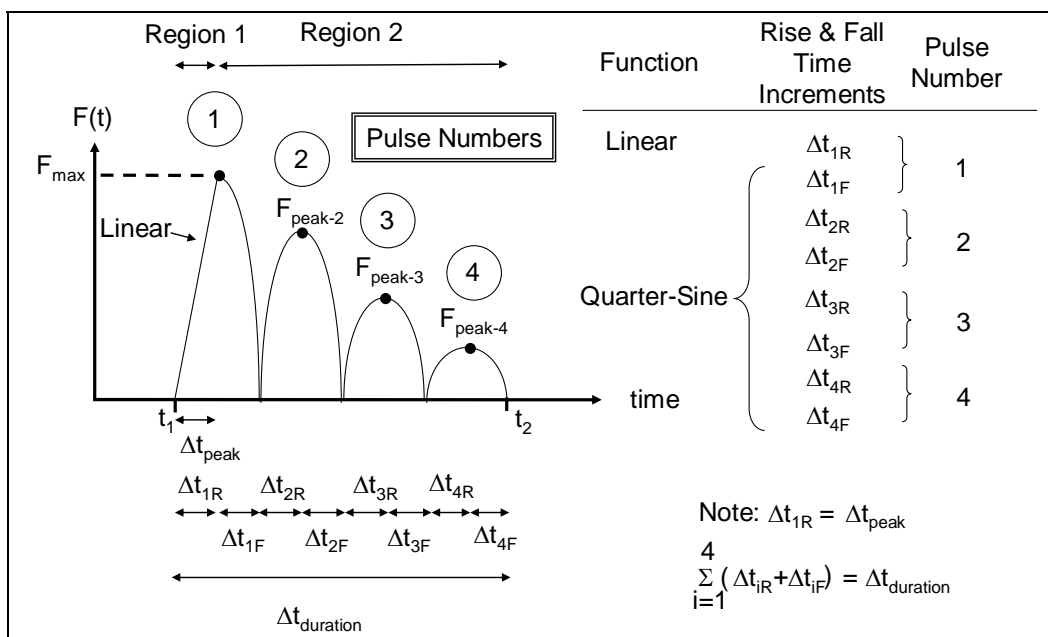

Figure 4.1. First example of a synthetic pulse force time history created using Impact_Force.

Table 4.1. First example of a user specified force time history consisting of 4 pulses with the maximum amplitude for pulses 2, 3, and 4 normalized by the maximum amplitude of pulse 1.

Pulse Number	Region(s)	Rise & Fall Pulse Types	F _{peak} /F _{max}
1	1 & 2	Linear & Quarter-Sine	1.0
2	2	Quarter-Sine & Quarter-Sine	0.7
3	2	Quarter-Sine & Quarter Sine	0.45
4	2	Quarter-Sine & Quarter-Sine	0.25

a rise time to peak force and a fall time from peak force to zero force, labeled for each pulse $i = 1$ to 4 as Δt_{iR} and Δt_{iF} in Figure 4.1. Observe in Figure 4.1 that at the end of each pulse and immediately prior to the start of the rise of the next pulse, the force drops to a value of zero for only one point in time. (Note that Impact_Force allows the user to specify a length of time of zero forces between the end of one pulse and the start of the second pulse.) A zero force designates the case of no contact between the barge train and the wall.

In Figure 4.1 the example pulse time history is divided into two regions, designated Region 1 and Region 2. Region 1 is defined by the time after t_1 to the time of peak force (designated F_{max} in the figure), Δt_{peak} . The time increment Δt_{peak} also corresponds to the rise time for pulse number 1, Δt_{1R} .

In the Figure 4.1 example, a linear relationship is specified by the user as the form of the force versus time relationship in Region 1; the rise time for pulse number 1. Impact_Force allows the user to select many forms of force versus time rise and fall pulse shapes, including

1. a quarter-ellipse,
2. a half-parabola,
3. a quarter-sine,
4. a linear function,
5. a step function, or
6. a straight-line function defined as a trapezoid.^{1,2}

Figure 4.2 shows examples of a quarter-ellipse, a half-parabola, a quarter-sine, a step function and a linear function for the Region 1 normalized force versus normalized (rise) time relationship. Note that the latter two, the step function and the linear function, are special cases of a trapezoid. A linear function has zero force amplitude at the start of the rise time and the step function has a start amplitude that is equal to the amplitude at the end of the rise time. The Figure 4.2 values for force are normalized by the maximum force that occurs at time Δt_{peak} . This data is also reported in Table 4.2; note the times have been normalized by Δt_{peak} in this Region 1.

The senior author's experience with interpretation the two full-scale field impact experiments conducted to-date on impacts with stiff-to-rigid walls (at Old Gallipolis Lock at Gallipolis Ferry, WV, and at Old Lock 2 on the Allegheny River, Pittsburgh, PA) indicates that in general, the form of the force versus time over Δt_{peak} time increment of Region 1 is more half-parabolic or quarter-sine in form than a step function or a linear relationship. A step function and the linear relationship provide upper and lower bounds, respectively, to the form of the relationship for rise time of this first pulse (Region 1).

Based on an interpretation of the 11 key impact force time histories recorded during the full-scale impact tests conducted at Old Gallipolis Lock, Arroyo et al. (2003) report (in their Table A.2) an average value for time to peak force, Δt_{peak} , of 0.17 second with a standard deviation of 0.04 second (coefficient of variation, COV = 0.25). The full-scale impact

¹ An example application of a trapezoid will be shown in the second example.

² Note that the linear function is a subset of a trapezoid, as is a pulse function.

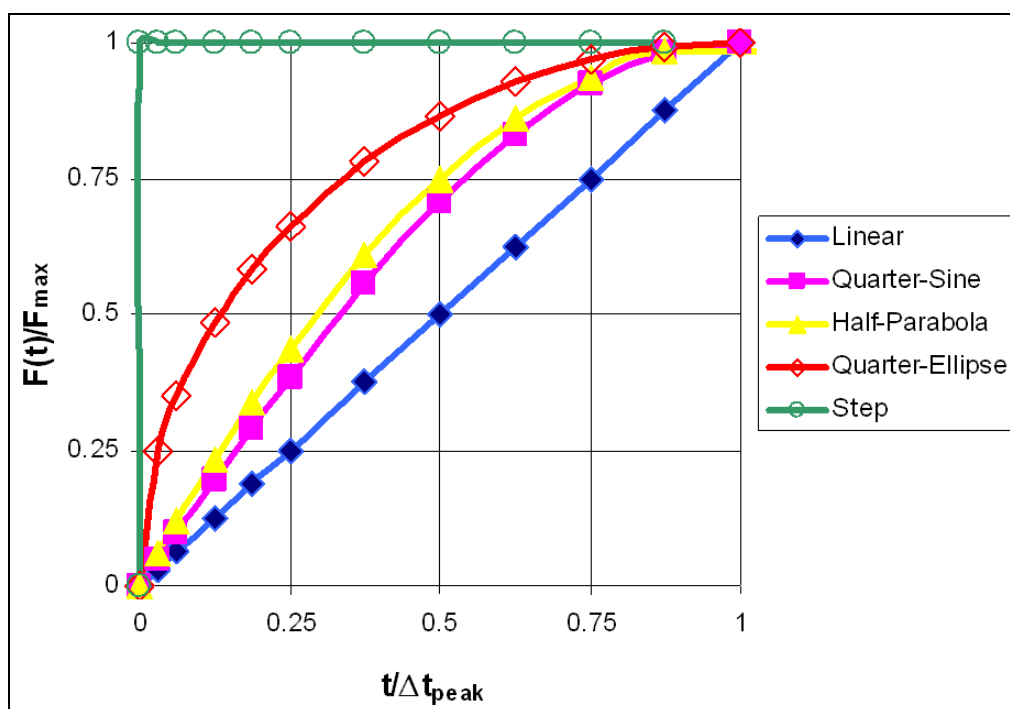

Figure 4.2. Variation in Force values $F(t)$ normalized by the peak force F_{max} versus normalized times of time t divided by Δt_{peak} (i.e., Δt_{1R} in Figure 4.1 notation) by five relationships for Region 1.

Table 4.2. Force values $F(t)$ normalized by the peak force F_{max} at normalized times of t divided by Δt_{peak} for five relationships for Region 1.

$t/\Delta t_{peak}$	F/F_{max}				
	Linear	Quarter-Sine	Half-Parabola	Quarter-Ellipse	Step
0	0.00	0.00	0.00	0	1.00
0.25	0.25	0.38	0.44	0.66	1.00
0.5	0.50	0.71	0.75	0.87	1.00
0.75	0.75	0.92	0.94	0.97	1.00
1	1.00	1.00	1.00	1.00	1.00

tests conducted at Old Gallipolis Lock using a 3-by-5 barge train did not mirror a lock approach so no $\Delta t_{duration}$ values may be gleaned from these full-scale impact experiments. However, the 18 key Prototype experiments conducted at Old Lock 2 on the Allegheny River did approximately mirror a lock approach by the 2-by-2 barge train. Table B.5 in this report summarizes the statistics of the time to peak for the first pulse (i.e., the maximum amplitude pulse) and the duration of each of the pulses (up to 5 pulses) for each of the (compression) strain gage time histories of the Prototype experiments. The mean time to peak of the first pulse was

0.13 second with a COV of 0.27. Values for $\Delta t_{\text{duration}}$ and using this same transverse strain gage on the deck of the barge closest to the point of impact ranged in value from a low of about 2.44 seconds to a high of 3.76 seconds, with a mean value of 3.05 seconds, and a COV of 0.11.

Table 4.3 summarizes the mathematical definitions of the four basic trigonometric pulse shapes used by the PC-based program Impact_Force and its solution procedure. Recall that the trapezoid pulse shape is used to create a step or triangular pulse shapes. The numerical solution to Equation 2.12 is summarized in this table.

Table 4.3. Mathematical definitions of the trigonometric pulse shapes used by the PC-based program Impact_Force and its solution procedure.

Trigonometric Pulse Shape	$F(\Delta t)$ equation for rise time of pulse i , with Δt measured from start of pulse i rise	$F(\Delta t)$ equation for fall time of pulse i , with Δt measured from start of pulse i fall
Quarter-Ellipse	$F(\Delta t) = F_{\text{Peak}_i} \cdot \sqrt{1 - \frac{(\Delta t - \Delta t_{\text{rise}})^2}{(\Delta t_{\text{rise}})^2}} \quad (4.1)$	$F(\Delta t) = F_{\text{Peak}_i} \cdot \sqrt{1 - \frac{(\Delta t)^2}{(\Delta t_{\text{fall}})^2}} \quad (4.2)$
Half-Parabola	$F(\Delta t) = F_{\text{Peak}_i} - \frac{F_{\text{Peak}_i}}{(\Delta t_{\text{rise}})^2} \cdot (\Delta t - \Delta t_{\text{rise}})^2 \quad (4.3)$	$F(\Delta t) = F_{\text{Peak}_i} - \frac{F_{\text{Peak}_i}}{(\Delta t_{\text{fall}})^2} \cdot (\Delta t)^2 \quad (4.4)$
Quarter-Sine	$F(\Delta t) = F_{\text{Peak}_i} \cdot \sin\left(\frac{\pi}{2} \cdot \frac{\Delta t}{\Delta t_{\text{rise}}}\right) \quad (4.5)$	$F(\Delta t) = F_{\text{Peak}_i} \cdot \sin\left(\frac{\pi}{2} \cdot \frac{\Delta t_{\text{fall}} - \Delta t}{\Delta t_{\text{fall}}}\right) \quad (4.6)$
Trapezoid	$F(\Delta t) = F_{\text{iR}_\text{pt.1}} + \frac{\Delta t}{\Delta t_{\text{rise}}} \cdot (F_{\text{iR}_\text{pt.2}} - F_{\text{iR}_\text{pt.1}}) \quad (4.7)$	$F(\Delta t) = F_{\text{iF}_\text{pt.1}} + \frac{\Delta t}{\Delta t_{\text{fall}}} \cdot (F_{\text{iF}_\text{pt.2}} - F_{\text{iF}_\text{pt.1}}) \quad (4.8)$

Note:

- $F_{\text{Peak}_i} = F_{\text{Peak}_\text{pulse } i} \cdot \text{FR}_i$;
- $F_{\text{iR}_\text{pt.1}} = F_{\text{Peak}_\text{pulse } i} \cdot \text{FR}_i \cdot \text{FR}_{\text{i}_\text{rise}_\text{pt.1}}$; and
- $F_{\text{iR}_\text{pt.2}} = F_{\text{Peak}_\text{pulse } i} \cdot \text{FR}_i \cdot \text{FR}_{\text{i}_\text{fall}_\text{pt.2}}$
- The values for each of the fractional maximum amplitudes of each pulse i , FR_i , are specified in the ASCII Group #8 data set to the PC-program Impact_Force, as discussed in Appendix C; typically, $0 \leq \text{FR}_i \leq 1.0$.
- The values for each of the fractional amplitudes for points 1 and 2 for each trapezoidal rise pulse i , $\text{FR}_{\text{i}_\text{rise}_\text{pt.1}}$ and $\text{FR}_{\text{i}_\text{rise}_\text{pt.2}}$, respectively, are specified in the ASCII Group #10 data set to the PC-program Impact_Force, as discussed in Appendix C; typically, $0 \leq \text{FR}_{\text{i}_\text{rise}_\text{pt.1}} \leq 1.0$ and $\text{FR}_{\text{i}_\text{rise}_\text{pt.2}} = 1.0$.

The values for each of the fractional amplitudes for points 1 and 2 for each trapezoidal fall pulse i , $\text{FR}_{\text{i}_\text{fall}_\text{pt.1}}$ and $\text{FR}_{\text{i}_\text{fall}_\text{pt.2}}$, respectively, are specified in the ASCII Group #10 data set to the PC-program Impact_Force, as discussed in Appendix C; typically, $\text{FR}_{\text{i}_\text{fall}_\text{pt.1}} = 1.0$ and $0 \leq \text{FR}_{\text{i}_\text{fall}_\text{pt.2}} \leq 1.0$.

Recall that the Equation 2.12 impulse-linear momentum principle normal to the approach wall is used to define this problem; with the two terms (on the left-hand side) of mass and velocity (i.e., the linear momentum) defined by the engineer's data input. Equation 2.12 is solved numerically by the PC-program Impact_Force in two computational steps:

$$\text{Unit_Area} = \int_{t_1}^{t_2} \text{FR}(t) \cdot dt \quad (2.17 \text{ bis})$$

with FR(t) representing the normalized force time history (i.e., with a maximum force of unity within the time history) as depicted in Figure C.3, generated using the user specified Group #'s 7 through 10 ASCII input data to the engineering FORTRAN program Impact_Force. The maximum amplitude for pulse number 1, F_{\max} , is computed using

$$F_{\max} = \frac{\text{RMF} \cdot m_{\text{barge train-normal}} \cdot (V_{1\text{-normal}})}{\text{Unit_Area}} \quad (2.18 \text{ bis})$$

The resulting force time history normal to the wall is

$$F_{\text{normal-wall}}(t) = F_{\max} \cdot \text{FR}(t) \quad (2.19 \text{ bis})$$

This is the pulse force time history to be used in the dynamic structural analysis of flexible/deformable approach walls. It is provided as an ASCII output file by Impact_Force.

A second example of a force time history consisting of a single-pulse is depicted in Figure 4.3 and whose pulse amplitudes are listed in Table 4.4 relative to the maximum amplitude of the pulse 1, designated F_{\max} . In this case of a single pulse, Region 1 depicts the rise time Δt_{1R} and Region 2 depicts the fall time Δt_{1F} . Recall that Δt_{1R} is equal to Δt_{peak} . A half-parabola represents the rise time force time history and a trapezoid represents the fall time force time history. For the trapezoid the forces at the starting and ending points are designated $F_{1F_pt.1}$ and $F_{1F_pt.2}$; the first subscript term designates the pulse number (1), the second designates it's the fall time (subscript "F") and the third term designates it as either point 1 or point 2, the starting or ending point for the trapezoid (i.e., 1 or 2, respectively). The force designated $F_{1F_pt.1}$ is equal to the maximum amplitude for pulse 1, designated F_{\max} .

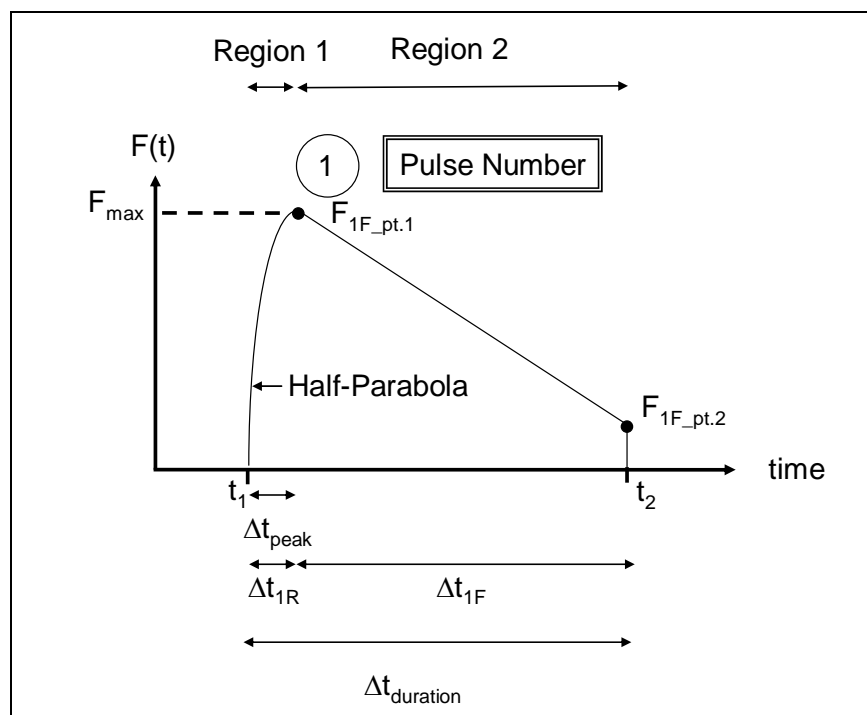

Figure 4.3. Second example of a synthetic pulse force time history created using Impact_Force.

Table 4.4. Second example of a user specified single pulse shape and relative magnitude for the pulse.

Pulse Number	Region(s)	Pulse Type	$F_{1Fpt.1}/F_{max}$	$F_{1Fpt.2}/F_{max}$
1	1 & 2	Half-Parabola & Trapezoid	1.0	0.2

This force time history is intended as depiction of a simplification of the case in which the barge train never loses contact with the wall during the entire duration of impact. Note that at time t_2 a non-zero force (normal to the wall) is depicted by the trapezoid assigned to Region 2. A non-zero force $F_{1Fpt.2}$ (recall subscript 1 refers to pulse 1, subscript F refers to the fall time, and subscript pt.2 refers to the second point for the trapezoid) does not occur in actuality at time t_2 but is a due to the action of “enveloping or averaging” of force time history response throughout an actual Region 2.

Other options in-lieu of a parabola for the Region 1 rise time of Figure 4.3 are listed in Table 4.3, with select amplitudes reported in Table 4.2 (recall that the values for force are normalized by the maximum force that occurs at time Δt_{peak} in Figure 4.3 and the times have been normalized by Δt_{peak} in this Region 1 in Table 4.2).

A third example of a force time history consisting of three separate pulses with quiet time between each of the pulses as depicted in Figure 4.4. The Figure 4.4 maximum amplitudes for the three individual pulses are listed in Table 4.5 and expressed as the maximum force amplitude relative to the amplitude of pulse 1 (designated F_{max}). Each of the three pulses has a rise time to peak force, a fall time from peak force to zero force and a quiet time of zero force, labeled for each pulse $i = 1$ to 3 as Δt_{iR} , Δt_{iF} and Δt_{iQ} in Figure 4.4. A half-parabola represents the rise time force time history for the first pulse and a quarter-sine represents the fall time force time history for the first pulse as well as the rise and fall time histories of subsequent pulses. Recall that the zero force during the quiet time designates the case of no contact between the barge train and the wall.

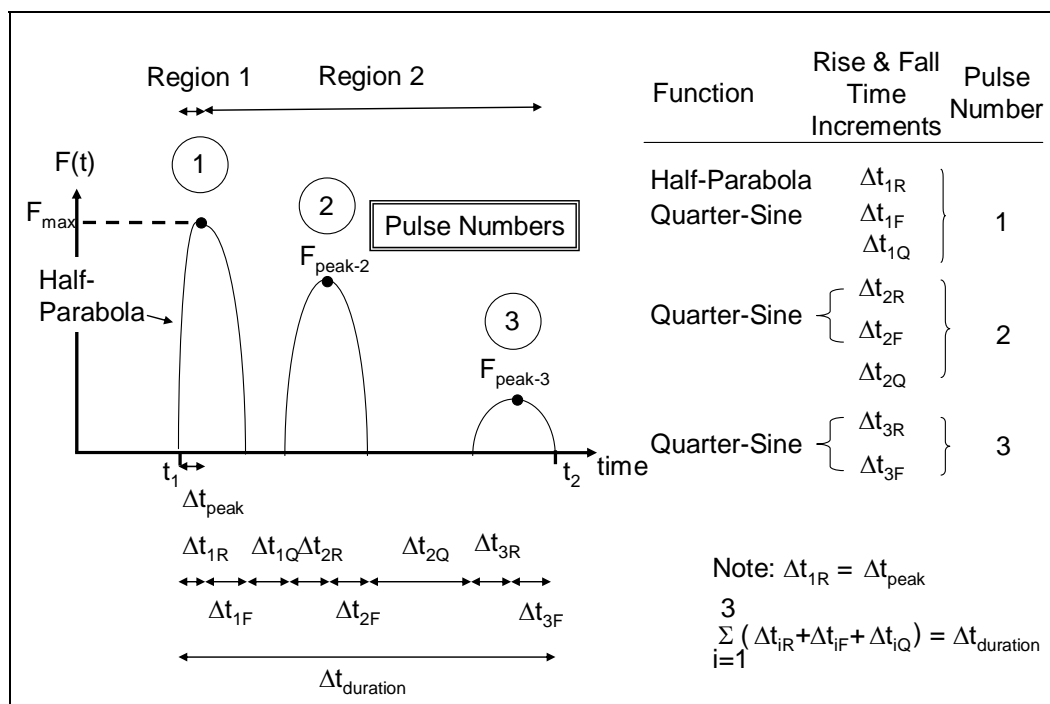

Figure 4.4. Third example of a synthetic pulse force time history created using Impact_Force.

Table 4.5. Third example of a user specified force time history consisting of 3 pulses with the maximum amplitude for pulses 2 and 3 normalized by the maximum amplitude of pulse 1.

Pulse Number	Region(s)	Rise & Fall Pulse Types	F_{peak}/F_{max}
1	1 & 2	Half-Parabola & Quarter-Sine	1.0
2	2	Quarter-Sine & Quarter-Sine	0.7
3	2	Quarter-Sine & Quarter Sine	0.25

Impact_Force allows the District Engineer to specify the form of the pulse force time history by specifying

- the duration of contact for the barge train with the wall, $\Delta t_{\text{duration}}$ ($= t_2 - t_1$),
- the time Δt_{peak} after initial contact (i.e., after t_1) to the peak force, designated as F_{max} , in the pulse force time history,
- the number of pulses contained within the force time history,
- the rise time, fall time and quiet time for each of the pulses,
- the maximum amplitude of the individual pulses normalized by the amplitude of the peak for the initial pulse (i.e., relative to F_{max}), and
- the functional shape for each rise and fall component of each pulse (i.e., as a half-parabola, a quarter-sine, or a straight-line function that is defined as a trapezoid).

Because the (trigonometric) attributes of each individual pulse of the force time history is specified (e.g., linear, half-parabola, quarter-sine, trapezoid, step, etc.), the timing of each of the pulses are defined and the relative amplitude of each of the four pulses is specified, it is possible to define the area under the impact force $F(t)$ versus time curve to be expressed in terms of a single independent variable, the maximum force of the first pulse F_{max} . This allows for the application of Equation 2.12 to solve for the value for F_{max} , via the relationship given by Equation 2.18. With the value for F_{max} determined, the force time history normal to the wall is now completely defined and ready for use in a dynamic structural analysis. Rapid execution of this engineering procedure is facilitated by the PC-based code Impact_Force, including its visual modeler. Output is a complete ASCII time history of impact force normal to the approach wall for a Corps lock. Because of the ease of data manipulation using the visual modeler, Impact_Force allows for rapid generation of time histories resulting from changes in the various input parameters. The visual modeler allows for immediate viewing of the generated force time histories.

A fourth example is a comparison of five synthetic force time histories consisting of four separate pulses with quiet time between each of the pulses. Linear (or triangular), quarter-sine, half-parabola, quarter ellipse and step trigonometric functions are specified for the rise and fall times in the five pulse force time histories. The time step used in Impact_Force is 0.005 second for each analysis. The data specified for this barge impact problem are as follows;

1. the approach angle θ is 5 degrees,
2. the initial approach velocity in local x,y barge coordinates (V_{1-x}, V_{1-y}) is 2.5 fps and 0.5 fps, respectively, at time of initial contact t_1 ,
3. a 3-by-3 barge train is involved for this impact with the approach wall, having a weight per barge of 3,880 kips and a tow weight of 1,100 kips,
4. the hydrodynamic added mass factors in the longitudinal and transverse local x,y barge axis directions are 1.05 and 1.4, respectively,
5. the duration of contact for the barge train with the wall, $\Delta t_{\text{duration}} (= t_2 - t_1)$ is 3 seconds (including all quiet times),
6. a time Δt_{peak} after initial contact (i.e., after t_1) to the peak force in the first pulse of the force time history is 0.3 second,¹
7. each of the four pulses in each of the five synthetic pulse force time histories share a common rise time to peak force, a common fall time from peak force to zero force and a common quiet time of zero force; for each pulse $i = 1$ to 4 $\Delta t_{iR} = 0.3$ second, $\Delta t_{iF} = 0.3$ second, and $\Delta t_{iQ} = 0.2$ second, and
8. the maximum amplitude of the second, third and fourth individual pulses, normalized by the amplitude of the peak for the initial pulse (i.e., relative to F_{max}), is given in Table 4.6.

Table 4.6. Fourth example of five user specified synthetic force time histories consisting of 4 pulses each and all with the same normalized maximum amplitudes.

Pulse Number	$F_{\text{peak}}/F_{\text{max}}$
1	1.0
2	0.75
3	0.5
4	0.25

¹ Section of a 0.3 sec time to peak was based on the desire for symmetry in each of the rise and fall times for each of the four pulses rather than consideration of the full-scale impact test data recorded at Old Gallipolis Lock or at Old Lock 2 on the Allegheny River during the Prototype tests.

Each of the four pulses in these five synthetic pulse force time histories are normalized by the peak maximum force of the first pulse, as shown in Figure 4.5. Recall that the zero force during the quiet time designates the case of no contact between the barge train and the wall. Table 4.7 lists the areas under each of the five Figure 4.5 unit pulse time histories (i.e., Unit_Area).

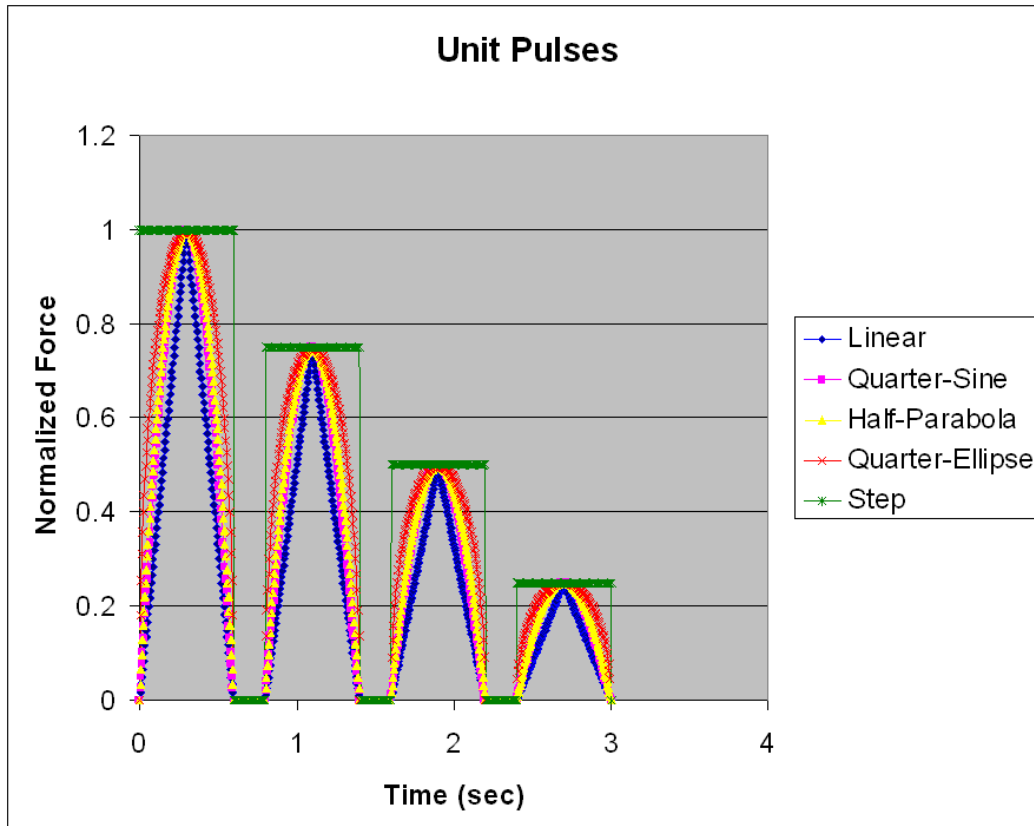

Figure 4.5. Fourth example of the five normalized pulse force time histories created using Impact_Force.

Table 4.7. Resulting areas under each of the five unit pulse force time histories of the fourth example.

Pulse Type	Unit Area (norm. force-second)
Linear (Triangle)	0.75
Quarter-Sine	0.955
Half-Parabola	1.0
Quarter-Ellipse	1.177
Step	1.5

The resulting five synthetic force time histories are shown in Figure 4.6; the barge train linear momentum is equal to 1,119 kips-second in all cases. The Figure 4.6 maximum amplitudes for the four individual pulses are listed in Table 4.8 and expressed as the maximum force amplitude relative to the amplitude of pulse 1 (designated F_{max}).¹

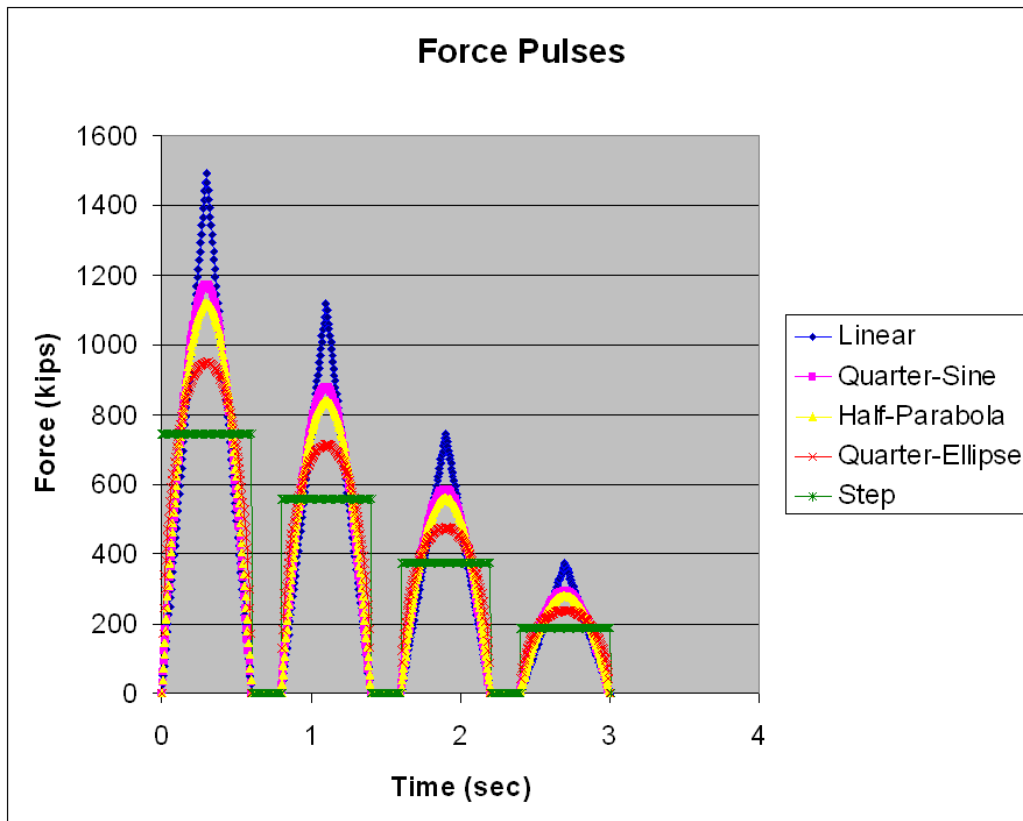

Figure 4.6. Fourth example of five pulse force time histories created using Impact_Force.

Table 4.8. Resulting maximum amplitudes for each of the five user specified force time histories of the fourth example.

Pulse Type	F_{max} of first pulse (kips)
Linear (Triangle)	1,493
Quarter-Sine	1,172
Half-Parabola	1,119
Quarter-Ellipse	951
Step	745

¹ The maximum amplitude for pulse number 1, F_{max} , is computed by Impact_Force using Equation 2.18.

It is observed that for the same value of linear momentum normal to the wall (of 1,119 kips-second), the peak force of the first pulse (i.e., F_{\max} listed in Table 4.8) diminishes as the (Table 4.7) unit area of the Figure 4.5 normalized pulse force time history increases, resulting in the magnitude of the Figure 4.6 peak pulse force decreasing in magnitude. The linear (or triangle) has twice the peak force of the step pulse. This is due to the fact that the linear or triangle pulse has the smallest unit area of 0.75 kips-second while the step pulse has the largest unit area 1.5 kips-second. The results for the other three trigonometric functions lay between these two extremes.

5 Visual Modeler GUI for Impact_Force

5.1 Introduction

This chapter introduces the Impact_Force graphical user interface. The various inputs and how they should be used are discussed. The visual modeler for Impact_Force is tab-based, with each tab dealing with a single conceptual issue in modeling the barge train and force time history for the solution satisfying the impulse momentum problem discussed in Chapter 2. Figure 5.1 shows the Introduction tab. Also shown on this figure are the titles for the other three tabs; Units and Barge Train, Time History, and Analyze. The different subsections of this chapter discuss each tab.

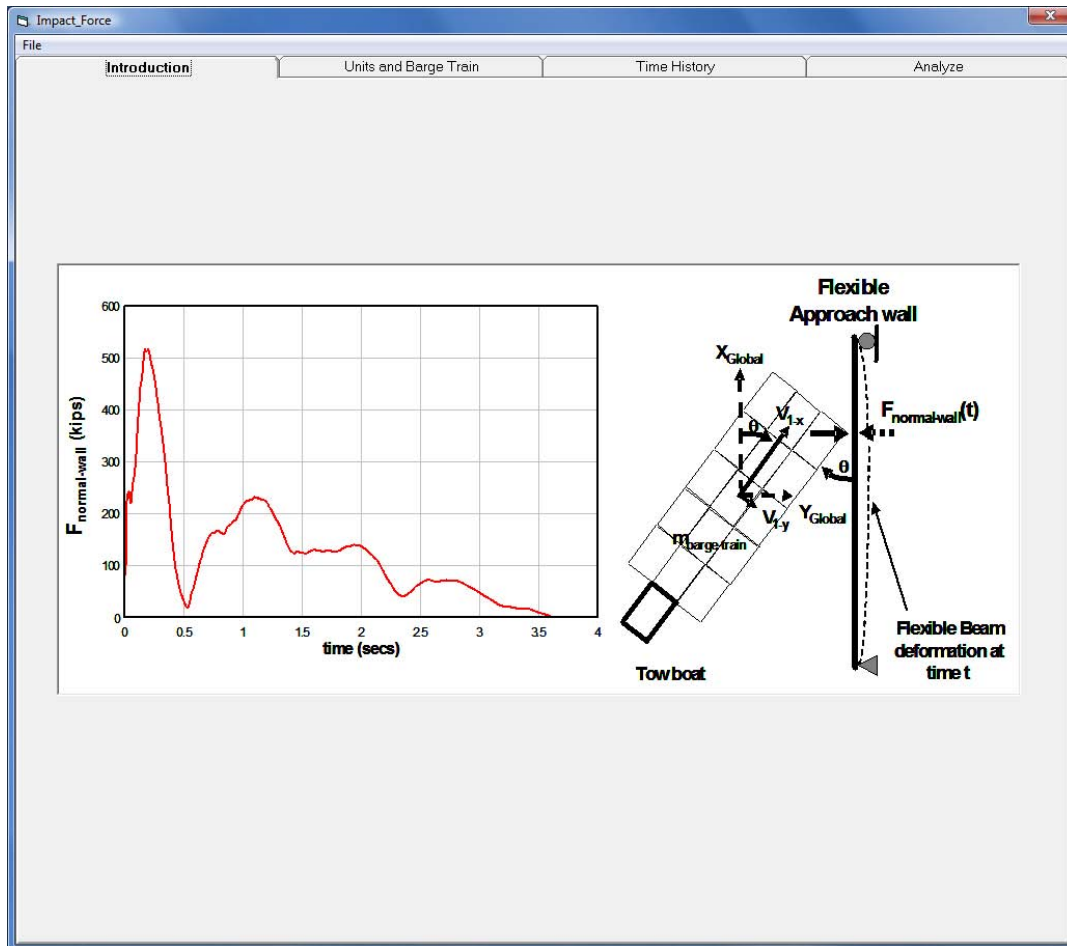

Figure 5.1. Introduction tab showing a force time history plot and a barge impacting a flexible approach wall.

5.2 Units and Barge Train tab

In this tab, the user chooses the units that will be used throughout the problem, and enters the description of the momentum terms (refer to Equation 2.15) that will be used in Equation 2.18. The interface for the Units and Barge Train tab is shown in Figure 5.2.

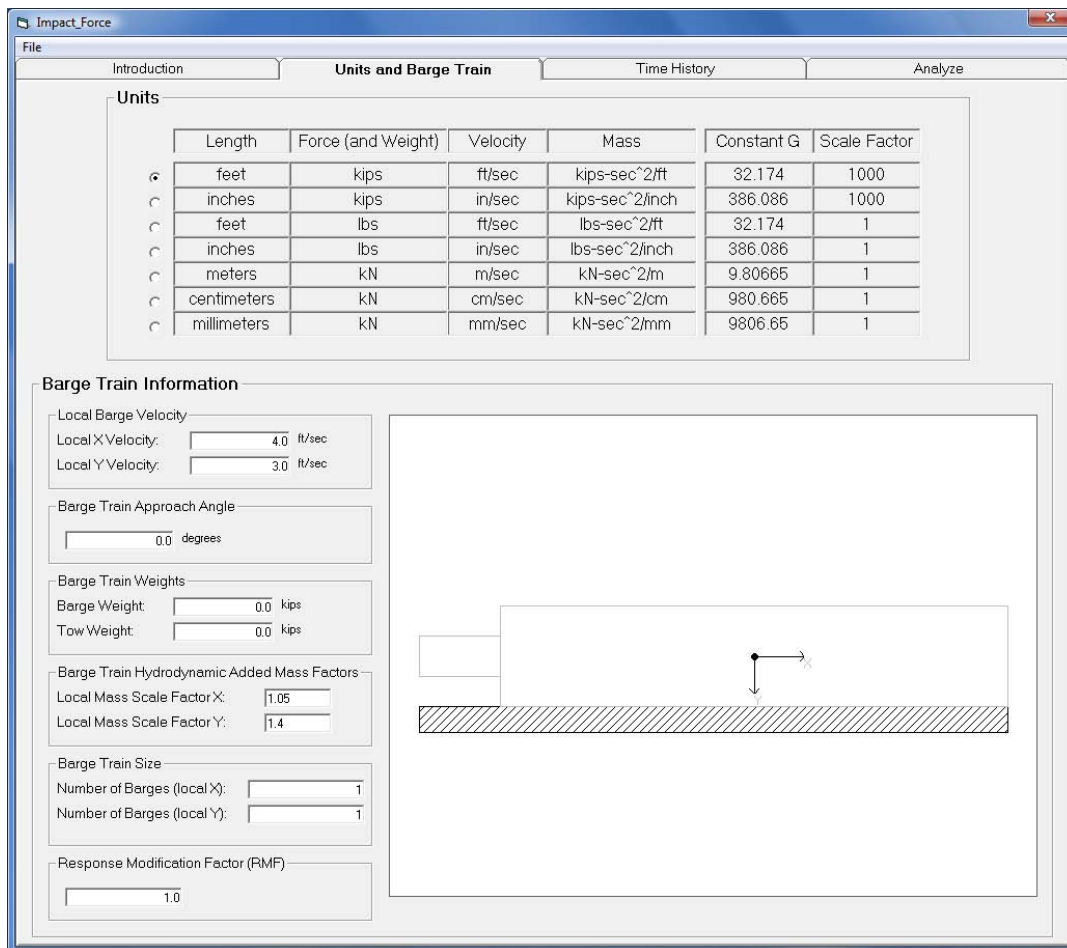

Figure 5.2. The Units and Barge Train tab.

The Units frame has a collection of radio buttons next to a chart of units. Simply selecting the appropriate radio button determines the units that will be used, as defined by the charts.

Next the user will interactively input data in regards to the following barge train information: velocity (in the barge-X and -Y local direction), approach angle, weights (barge and tow), hydrodynamic added mass factors, and size (X and Y local direction) in the Barge Train Information

frame. As input is received, the visual representation of the barge train is updated in the picture box to the right as a visual confirmation.

***Note: The units to the right of the input text boxes change in correspondence to the units selected in the table as shown in Figure 5.3.**

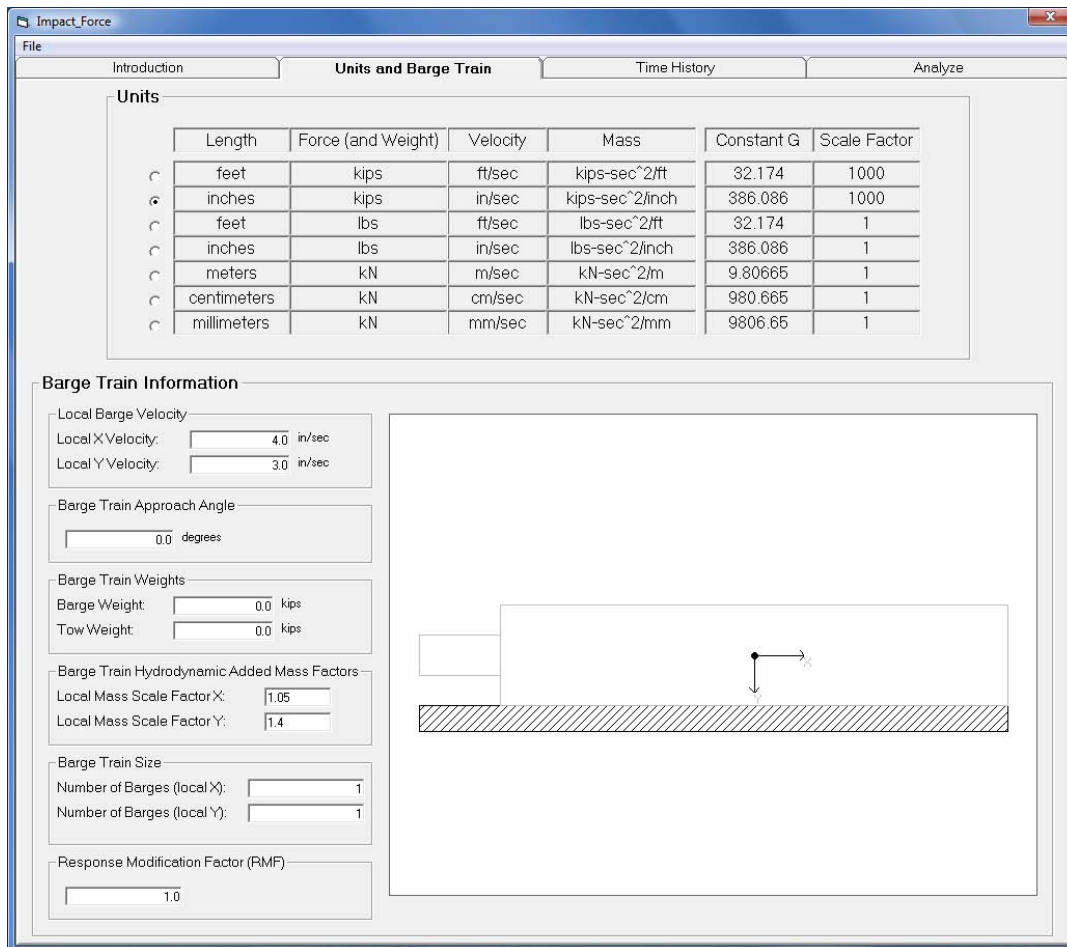

Figure 5.3. Showing that the units to the right of the input text boxes change accordingly to the units selected from the table.

Figure 5.4 shows the result of selecting units of feet, kips, etc., and inputting a 3-by-5 barge train. In this example, each barge weighs 3,300 kips and the tow weighs 550 kips. The barge train approaches the wall at 20 degrees, with a forward velocity (along the local x axis of the barge coordinate system) of 4 ft/second and a transverse velocity of 3 ft/second.

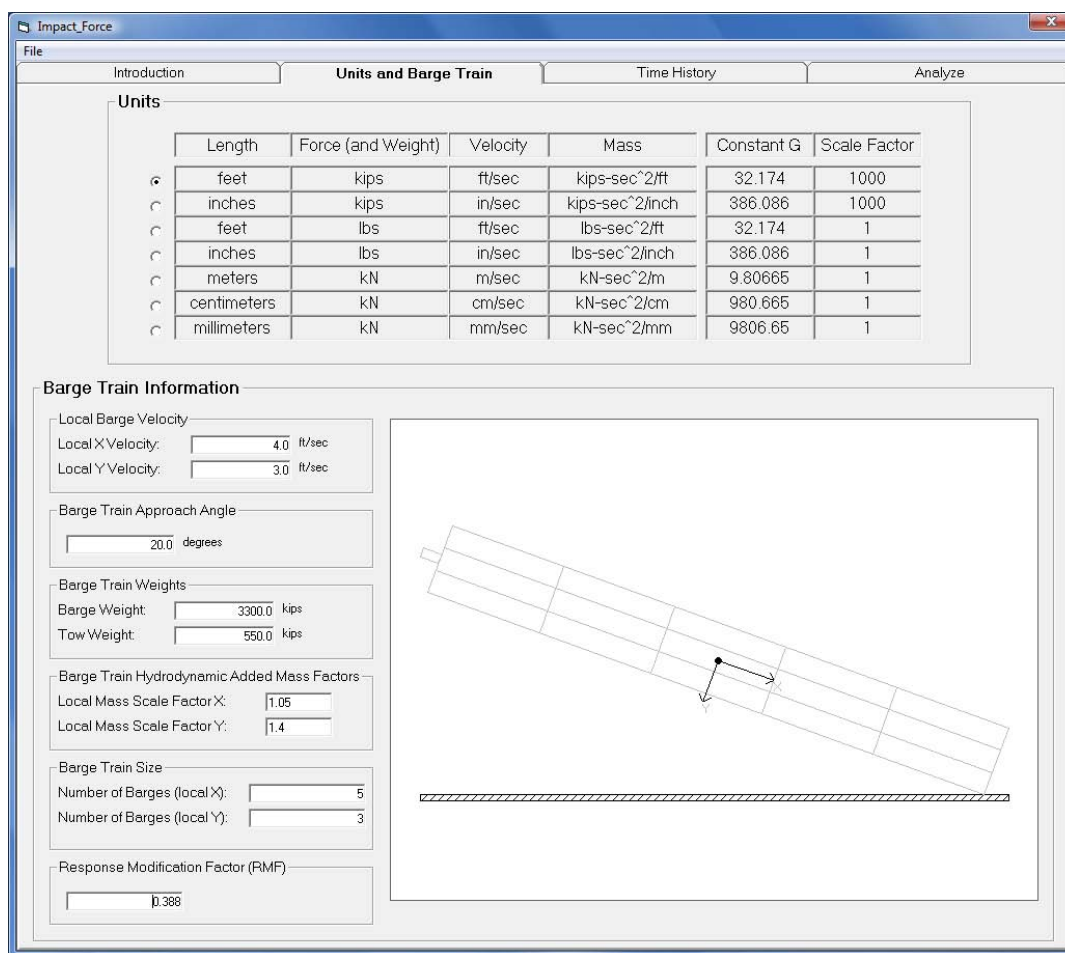

Figure 5.4. Modeling a 3-by-5 Barge Train.

The ETL 1110-2-338 hydrodynamic added mass factors are currently the default values (refer to Equations 2.3 and 2.4). The Response Modification Factor (RMF)¹ default value is 1.0 but is set equal to 0.388 in this example, which is the computed RMF value for Winfield Experiment #10 (Table A.5 in Appendix A). The full-scale barge impact experiment and data collection is discussed in Barker et al. (in press). Winfield Experiment #10 will serve as the selected time history example in Section 5.3.1. Note that Table A.5 in Appendix A lists the computed RMF values for the other Winfield Experiments as well. Recall from the discussion in Chapter 2 that the 2008 Winfield full-scale test data indicates a mean (μ), standard deviation (σ) and coefficient of variation (COV) for the RMF value of $\mu = 0.397$, $\sigma = 0.047$, and $\text{COV} = 0.118$, respectively.

¹ Refer to Equation 2.13 for the application of the RMF to the Linear Momentum term of the Impulse-Momentum principle in Impact_Force.

5.3 Time History tab

The Time History tab is more complex than the Unit and Barge Train tab. Its inputs define the impulse terms of the equations discussed in Section 2.8 of Chapter 2. This tab is broken down into two sections: the time history selection section and the time history editing section.

5.3.1 Select Time History

This section is the first available when the Time History tab is selected. It allows the user to make a preview list of existing time histories files. Figure 5.5 shows how the tab appears when it is first entered. There are four important tasks to be performed in the selection window: selecting a file to preview, previewing time histories, choosing a time history, and proceeding to the time history editor (which finalizes the selection).

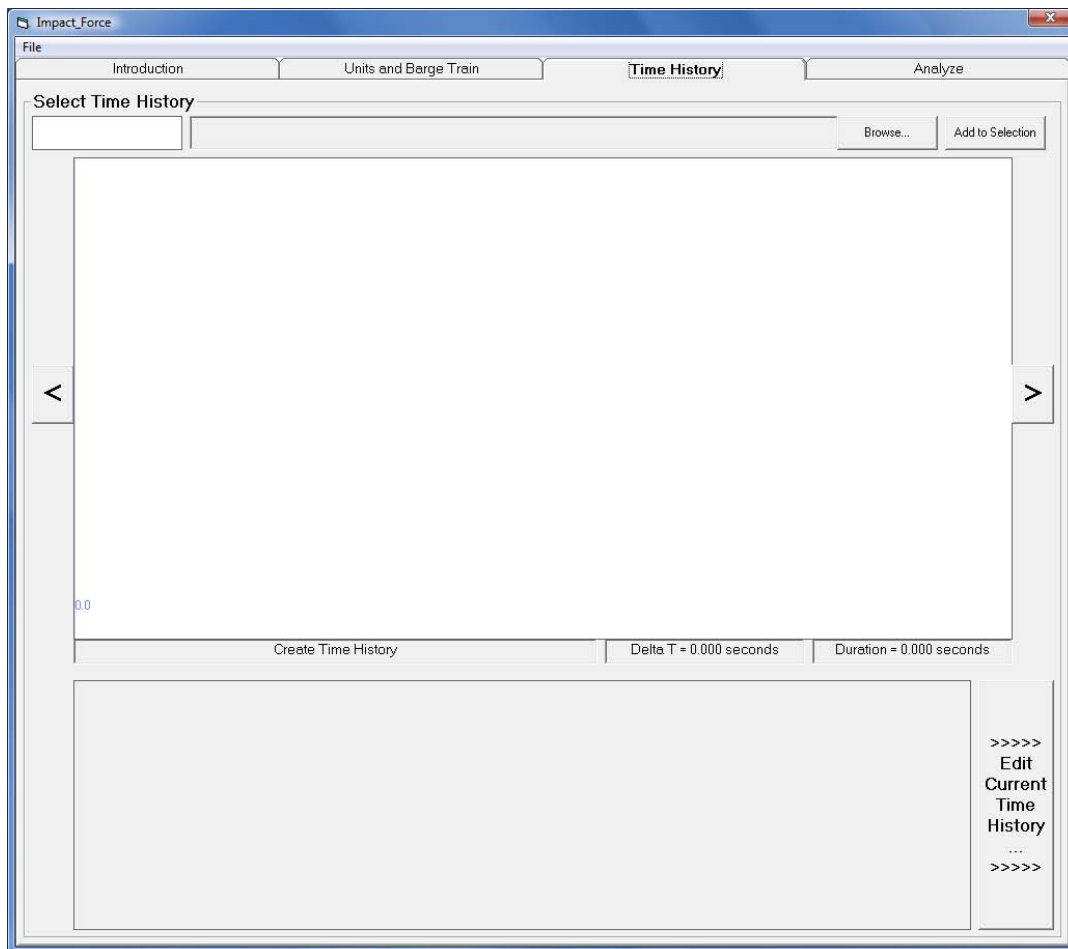

Figure 5.5. The Time History selection window.

To select a file to preview, click the “Browse” button at the top of the tab. A file open dialog will appear, allowing the user to open unit time-history data with an extension of “.uth” (“uth” denotes unit time history, a time history that has been normalized by the maximum value contained within the pulse). It may be necessary to navigate to the directory where the unit time-history data is stored. When the program was installed there were three directories created to store the time histories: a Winfield directory, Pittsburgh directory, and a User-created directory. The user-created time history directory is initially empty. The Winfield directory contains pulse force time histories (normal to the wall) recorded during the 2008 full-scale impact experiments, each of which have been normalized by their maximum force value. The Pittsburgh directory contains pulse time histories recorded during the 1997 full-scale impact experiments, each of which have been normalized by their maximum (strain) value. Figure 5.6 shows the user browsing the Winfield unit (i.e., scaled) time-history data.

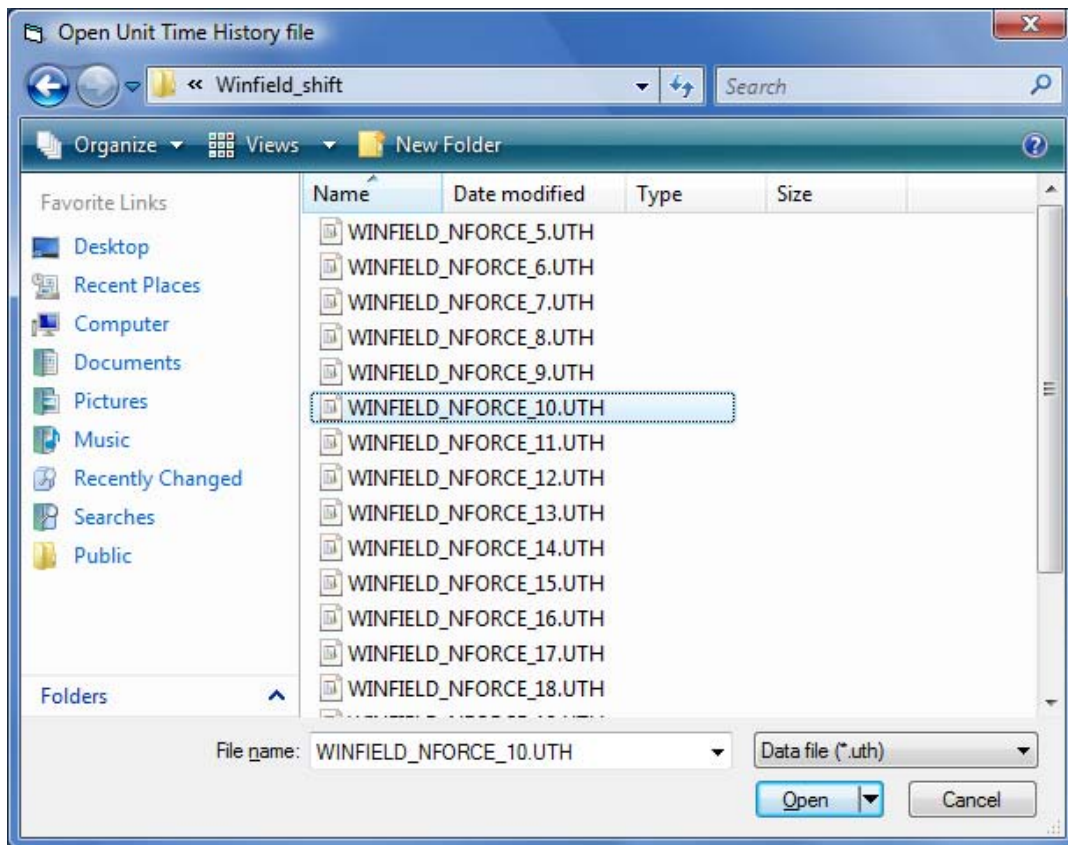

Figure 5.6. Browsing for Unit Time History data.

When a file has been selected, its name is displayed in the label next to the browse button, and a small visualization is shown in the small picture box at the upper left of the tab. This is a quick preview to ensure that the data follows the curve that the user is expecting. If the curve is what was expected, the user can click the “Add to Comparison” button at the upper right to drop the time history into the Comparison box, which takes up most of the screen (Figure 5.7). Observe that for the WINFIELD_NFORCE_10.UTH pulse force time history has a maximum amplitude of unity in Figure 5.7.

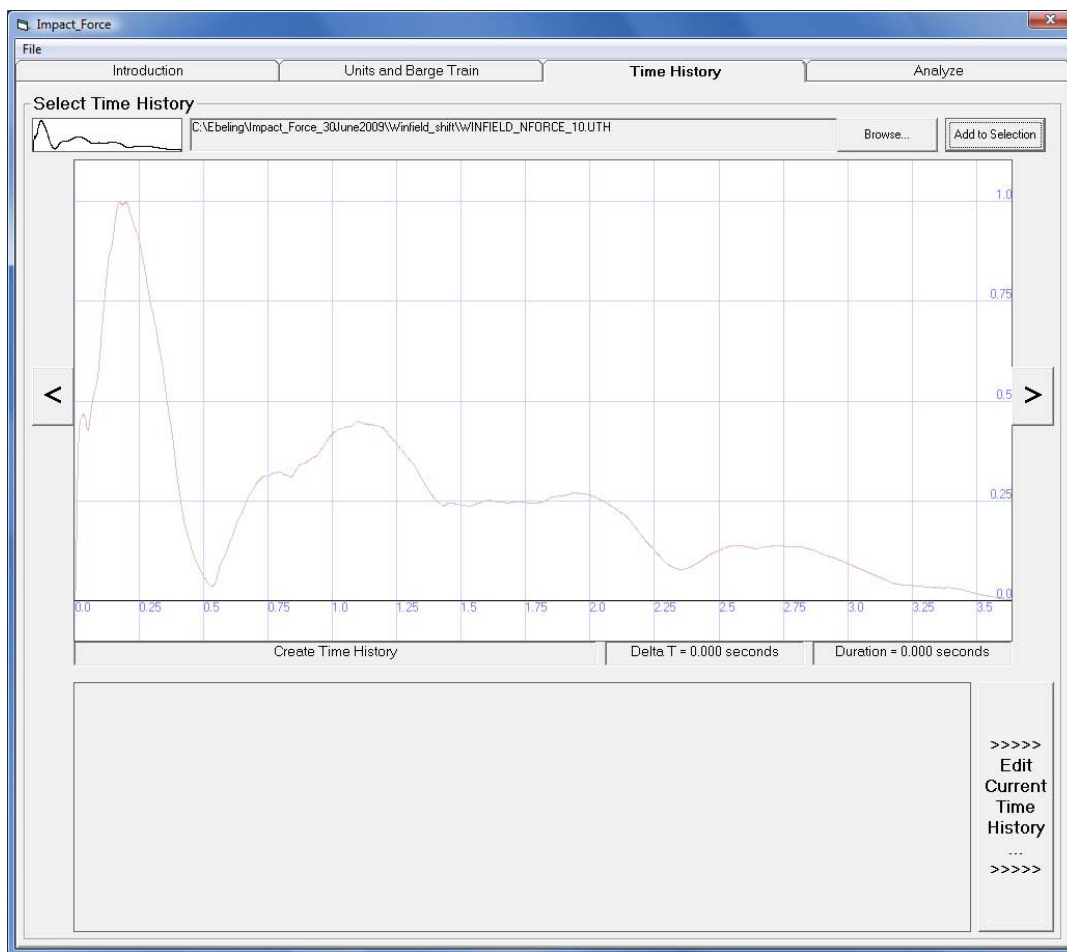

Figure 5.7. Adding a Time History to the Comparison Window.

Several time histories can be compared by adding them to the comparison window. The currently selected time history is drawn in black and its name and properties are displayed in the labels below the comparison window. By default, an empty time history called “Create Time History” is selected, but other time histories can be highlighted by clicking the back and forward buttons on either side of the comparison window (Figure 5.8)

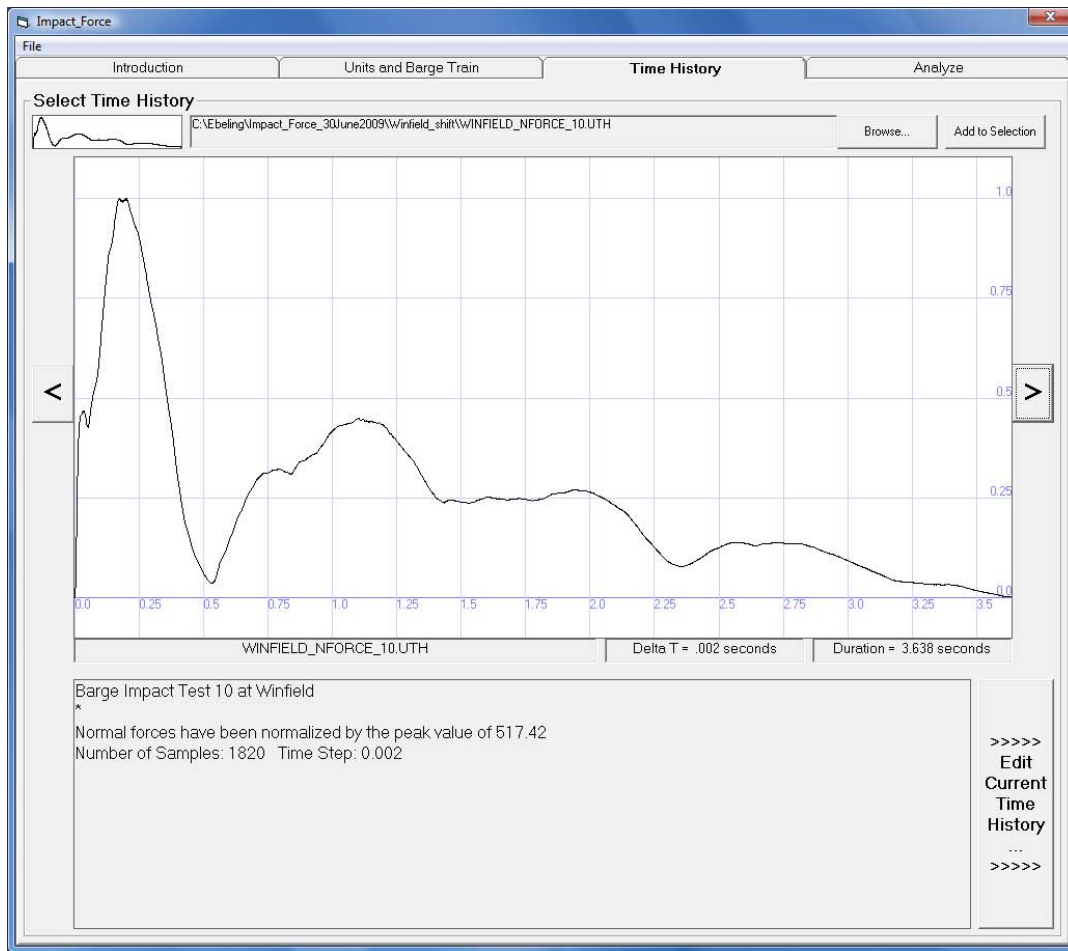

Figure 5.8. Changing the Currently Selected Time History.

To edit a unit time history, the user must select the “Edit Current Time History” button at the bottom right of the selection window. The current time history is then passed to the editor.

If “Create Time History” is the currently selected time history, a dialog for creation of a unit time history is presented. This dialog creates an empty time history from information about the length of a time step and duration of the entire history. Figure 5.9 shows the Create New Time History Dialog.

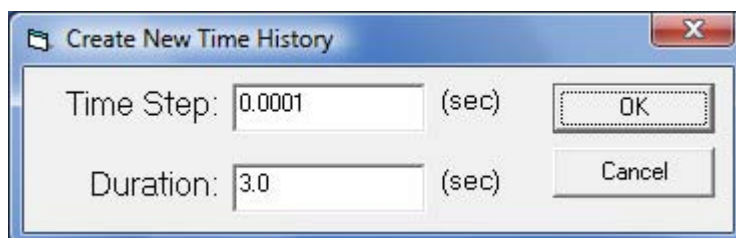

Figure 5.9. Create New Time History Dialog.

5.3.2 Edit Time History

When a time history has been selected for editing and the “Edit Current Time History” button has been pressed, the input tab is changed so that the time history can be edited. The change is accompanied with a visual cue so the user is made aware that a time history has been selected and is available for modification.

Figure 5.10 shows the results of creating a new, empty time history. The number of time steps is 30,001 and the interval between time steps is 0.0001 second (refer to the label under the graph). Empty time histories can be edited in much the same way as selected time histories.

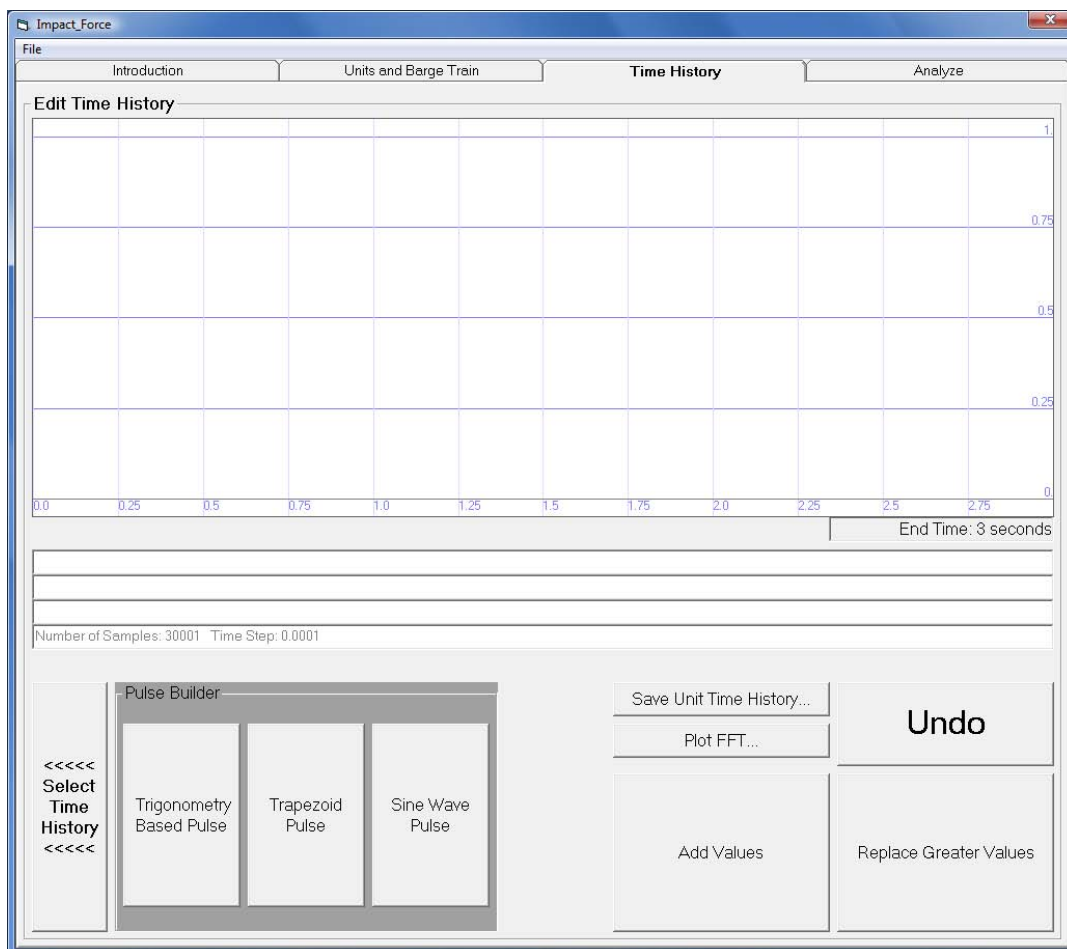

Figure 5.10. The Time History Created from the Dialog in Figure 5.9.

Figure 5.11 shows the new configuration of the Time History tab with the Winfield Test 10 data passed to it. The data view window shows the current time-history data. Three text boxes allow the user to describe the data, while additional labels provide additional information about the data.

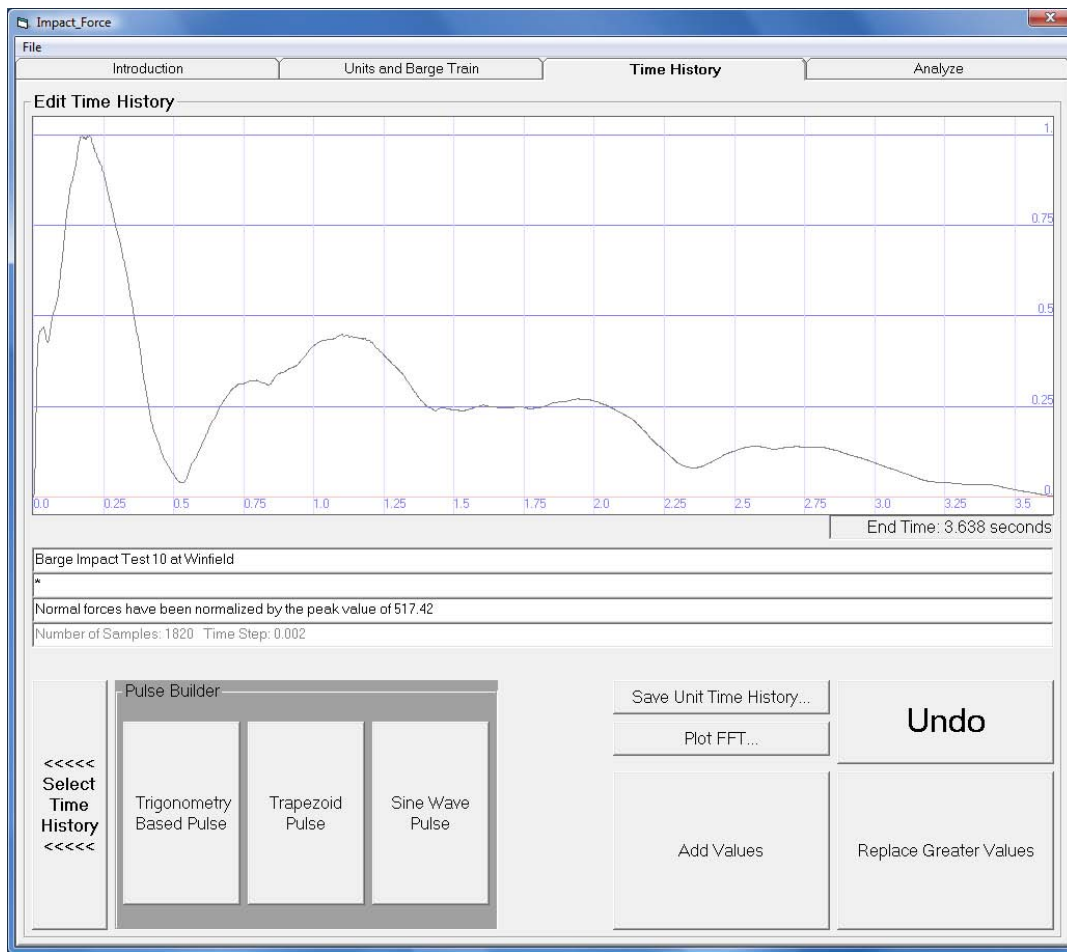

Figure 5.11. Editing the selected time-history data.

If the current time history was chosen in error or if the user would like to return to the selection mode at any time, the “Select Time History” button will return the tab to the selection mode. Note that selecting and editing a time history and then returning to the selection mode means that a time history has not been selected for the analysis. Only the current time history in “Edit Time History” mode of the “Time History” tab will be passed to the “Analyze” tab for analysis.

There are several simplified methods used to create new time histories from existing time-history data in this mode. One method allows for a new

pulse to be created by combining the current time history in some way with a user specified waveform. The buttons that contain those functions are in the Pulse Builder frame and separated by the darker background. To the right are the buttons for combining the pulse data with the original data, as well as functions for storing and finding additional information about the current time history.

The Sine Wave Pulse button allows the user to combine standing sine wave information with the current time history. Clicking the button reveals the dialog shown in Figure 5.12. When the dialog is opened up, the display window shows a standing wave with a length equivalent to the current unit time history length.



Figure 5.12. Sine Wave Pulse Dialog.

A sine wave is created in the display window by specifying the amplitude of the sine wave and frequency. Sine wave frequency is entered in units of frequency in hertz, period in seconds, or the angular velocity in radians per second. Entering any of the three frequency components will (automatically) alter the other two corresponding values describing the frequency. For example, entering a frequency of 2 hertz will change the period to 0.5 second and the radians per second to pi. The phase for the

sine wave is not specified, meaning that the sine wave will always begin with a value of zero.

When the amplitude and frequency have been entered, the sine wave with those characteristics is shown in the display window in red. It is not accepted until the “Add Frequency Component” button next to the frequency input is pressed. At that point, the sine wave is summed with the existing data, shown in black. Multiple sine waves can be summed to create more complex wave forms. Typically, only frequencies that may affect the relevant structural system natural frequencies are added.

Unfortunately, the user specified (sine wave) data will rarely be of zero amplitude at the end of the pulse time history. To ensure this constraint, a “fade function” was added to the sine wave pulse generator, as shown in Figure 5.13. Its input is a delta time, measured backwards in time, from the end of the time history. This describes a linear drop off of the magnitude of the existing waveform, starting at the delta fade time from the end of the wave. This linear drop-off scales the existing waveform to gradually reduce the value to zero by the last time step of the waveform. The resulting sine wave is the multiplication of this scale curve and the original sine data.

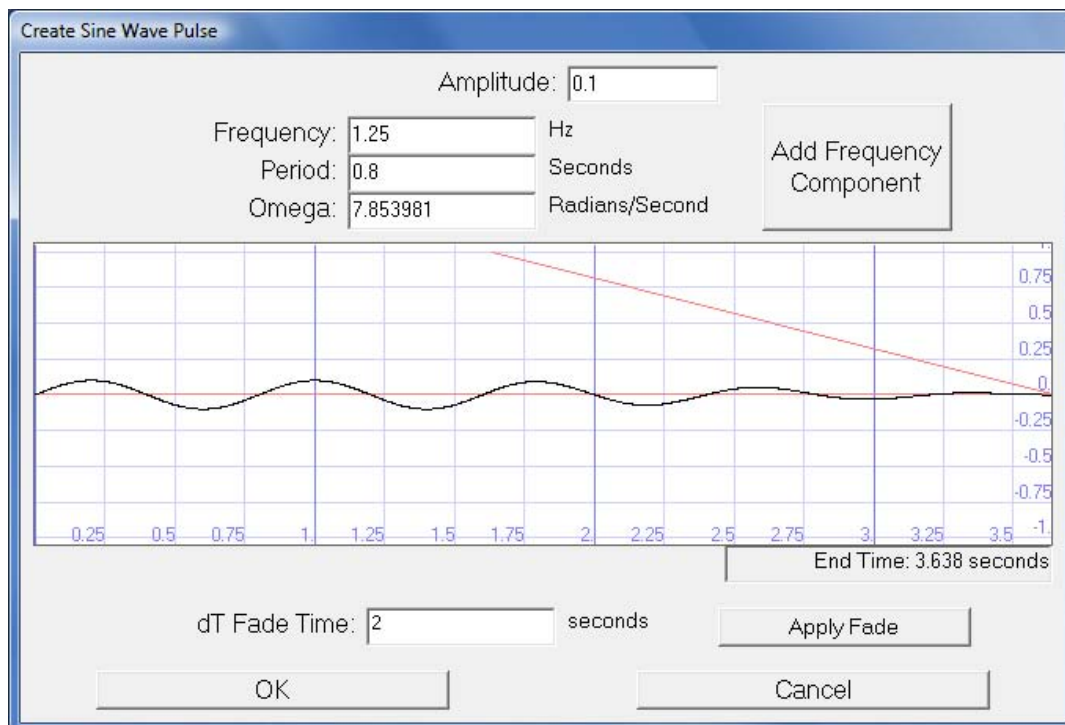

Figure 5.13. Slope line from applying fade function.

When the sine data is fully defined, Click OK to return to program with the modified sine curve, so that it can be applied to the existing time history. The pulse history we've created is shown in red in the data view window, as in Figure 5.14.



Figure 5.14. The Sine Wave Pulse History before combining with the Current Time History.

The created sine wave pulse time history can be combined with the current time history in two ways: the first way is accessible through the “Add Values” button. This method sums, on a time-step by time-step basis, the current time history and the pulse time history. After the values are added together, values less than zero are “clipped” to zero. The summed and clipped waveform is then renormalized to have a unit peak value (Figure 5.15).

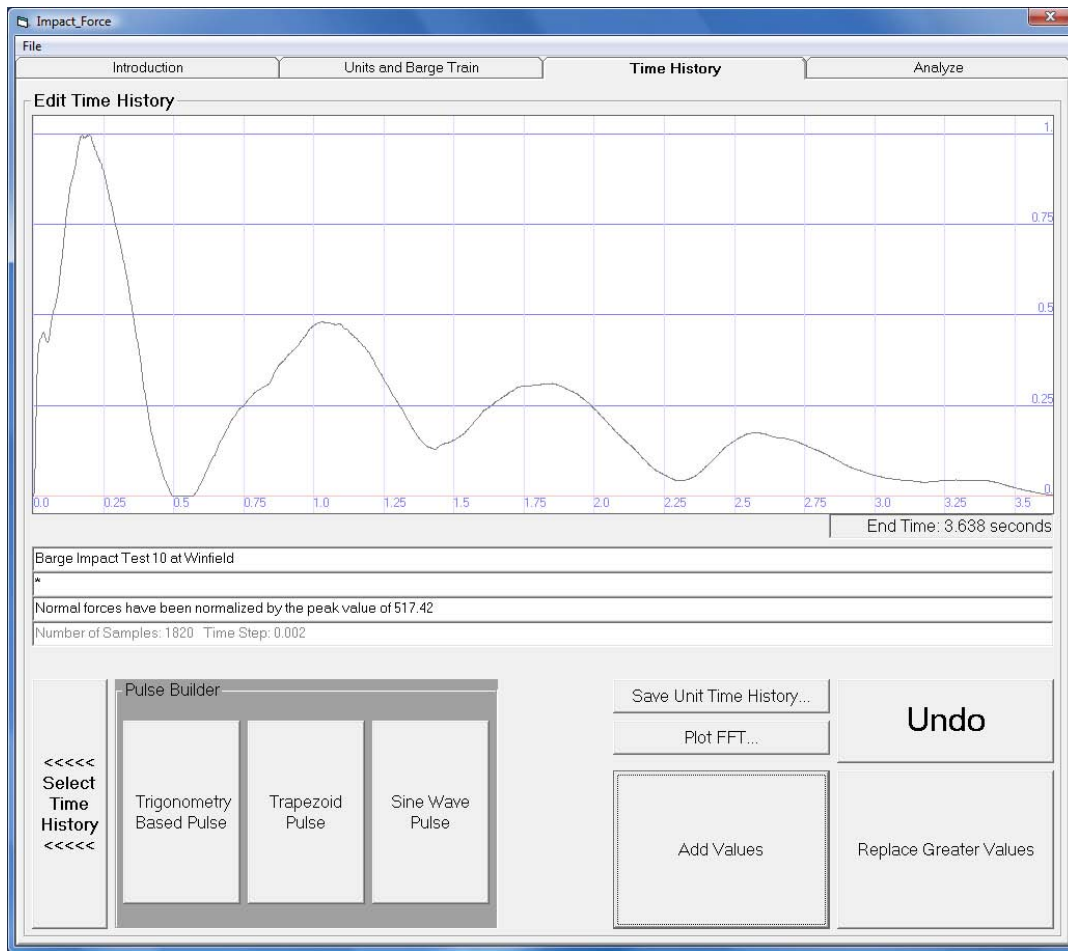

Figure 5.15. Using the “Add Values” Button to Sum the Sine Wave Pulses and the Winfield Test 10 data.

Another way to combine the data is to use the “Replace Greater Values” button. This method does a time-step by time-step comparison and replaces values in the original data with pulse data if the pulse data is greater. Because these results will always generate non-negative results, the resulting time history will not need to be clipped. However, there is a possibility of exceeding the unit value, so the resulting pulse time history is renormalized to have a unit peak value.

Synthetic Time History: The other methods for generating pulse time histories are accessed by the “Trigonometry Based Pulse” button and the “Trapezoid Pulse” button. Both of these start a dialog similar to the “Sine Wave Pulse” button, but each can only create a single pulse for combining at one time, and will rarely be used to modify existing data. These tools are better used for generating new (i.e., synthetic) pulse time histories.

The “Trigonometry Based Pulse” button opens a dialog allowing the user to make pulses based on trigonometric functions (shown in Figure 5.16). To build a new pulse the user specifies a peak value, the absolute time of that the peak value is reached, and the length of lead-up and fall-off time, as shown in the example at the top of the form. If the values for the lead-up or fall-off times go beyond the time-history data that is being edited, these values are truncated to the start and end times of the original time history, respectively.

Generate Pulse

Start Method Peak Value End Method

delta T start Peak Time delta T end

Peak Value:

delta T start: Peak Time: delta T end:

Start Method

quarter ellipse

half parabola

quarter sine

linear

step

End Method

quarter ellipse

half parabola

quarter sine

linear

step

0.25 0.5 0.75 1 1.25 1.5 1.75 2 2.25 2.5 2.75 3 3.25 3.5

0 0.25 0.5 0.75 1

OK Cancel

Figure 5.16. Trigonometry Based Pulse Dialog.

Once the time values and peak value have been entered, the methods for the lead-up and fall-off can be selected. The methods are the same as those discussed in Chapter 4 and most specifically in Table 4.3, with one exception. That exception is that a step function has been added, to allow for square pulses.

As these values are being entered, the visual display underneath the method frames is updated to show how the resultant pulse will appear. Clicking OK accepts the input in the same manner as the sine pulse, and can be combined with the same two methods.

The “Trapezoid Pulse” button opens a dialog similar to the Trigonometry Based Pulse dialog. The same visual elements apply, with an example displayed at the top and an updated visual display underneath the inputs (shown in Figure 5.17).

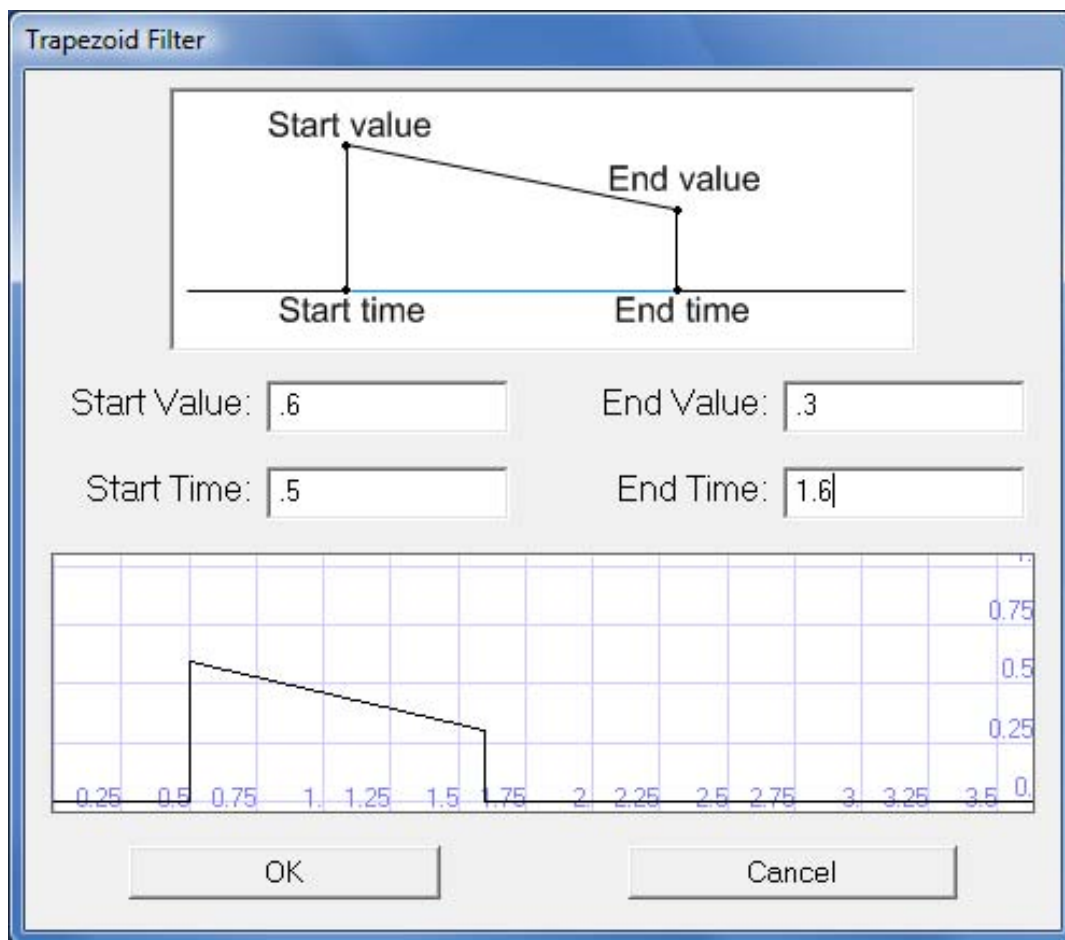

Figure 5.17. Trapezoid Pulse Dialog.

The inputs are the peak values specified at absolute time values. The resulting pulse has a step function to the start value and from the end value. Values are linearly interpolated between the start and end times. Right triangle pulses can be generated by setting the start or end value to zero.

Clicking OK will place the resulting pulse time history in the Edit Time History frame to be combined with the current time history.

Multiple changes can be made to the current time history using the “Add Values” and “Replace Greater Values” buttons. Consecutive creations of pulses and combinations can create complex time histories. But sometimes a pulse can be combined in error. The Undo button allows the user to restore data before the changes were made. Multiple undos are allowed, taking the user back to the original data.

If the user is pleased with the changes made to an existing time history or newly created time history, these changes can be saved to a new unit time history file by clicking the “Save Unit Time History” button. A save file dialog box is brought up and the time history will be saved in the “.uth” format described in Section 5.3.1.

The user is also given an opportunity to view the data in the frequency domain instead of the time domain by clicking the “Plot FFT...” button. A dialog appears showing the most significant frequencies in the time history. Because frequency information is more likely to be in the lower bands for pulse time histories, the higher frequencies that contain very little energy are removed from the plot, allowing the user to concentrate on frequencies that have more of an effect for the approach wall. This dialog can help the user identify problem frequencies or how combined pulses have changed frequency information.

5.4 Analyze tab

The Analyze tab allows the user to run the Impact_Force program and view the consequent output. Before the data can be run, valid input must be entered on the Units and Barge Train tab, and a unit time history must be in the Edit Time History frame of the Time History tab. If these conditions are met, the “Run Analysis” button is enabled, as shown in Figure 5.18.

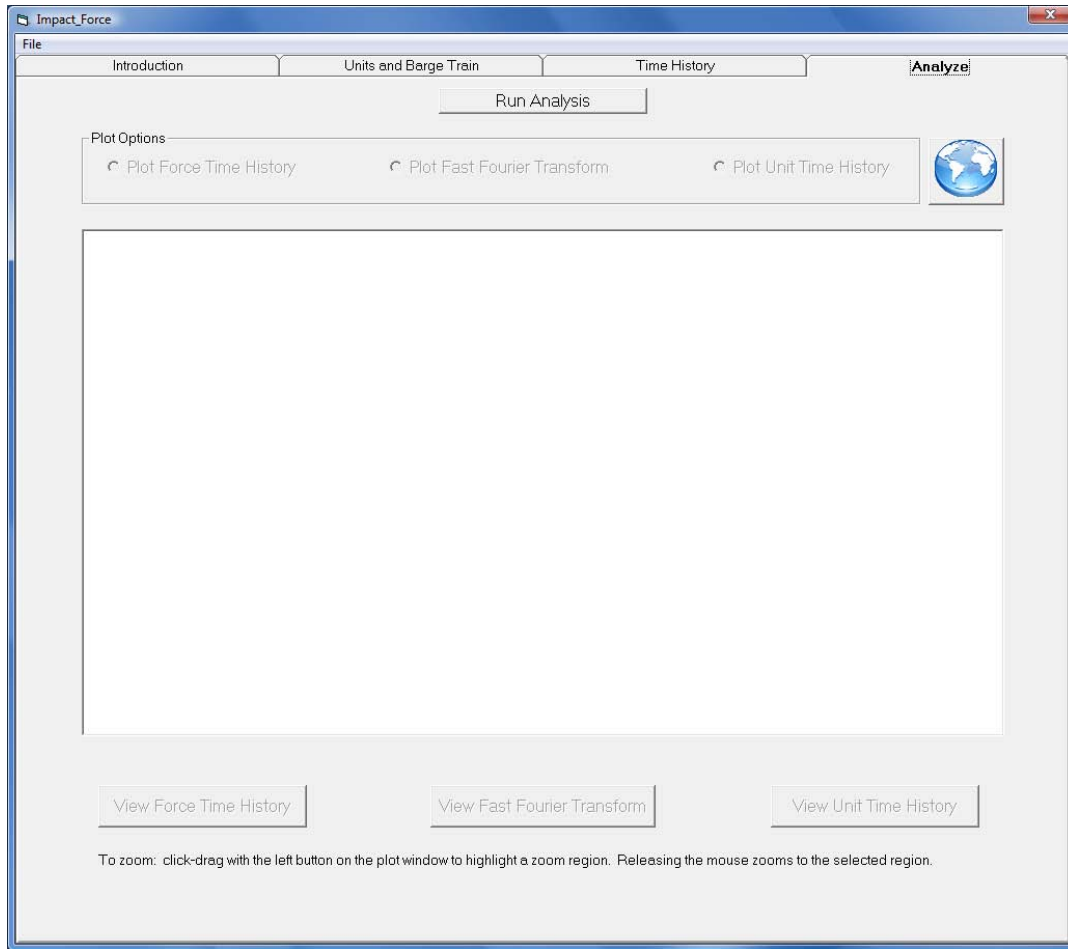

Figure 5.18. Analysis tab.

Clicking Run Analysis will execute the Impact_Force program on the data that was entered for the Units and Barge Train tab and the Time History tab. After the analysis has been performed, a message box will alert the user that the Impact_Force program has finished analyzing the data (shown in Figure 5.19).

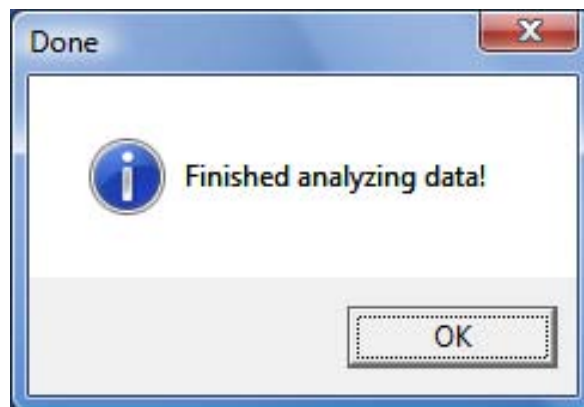

Figure 5.19. Finished analyzing data message box.

Clicking OK will allow the user to have the choice in plotting or viewing the three output files that were created from running the analysis. The three output files that were created are the Force Time History, the Fast Fourier Transform Time History, and the Unit Time History. Figure 5.20 displays the plotting and viewing options being enabled after clicking the OK button.

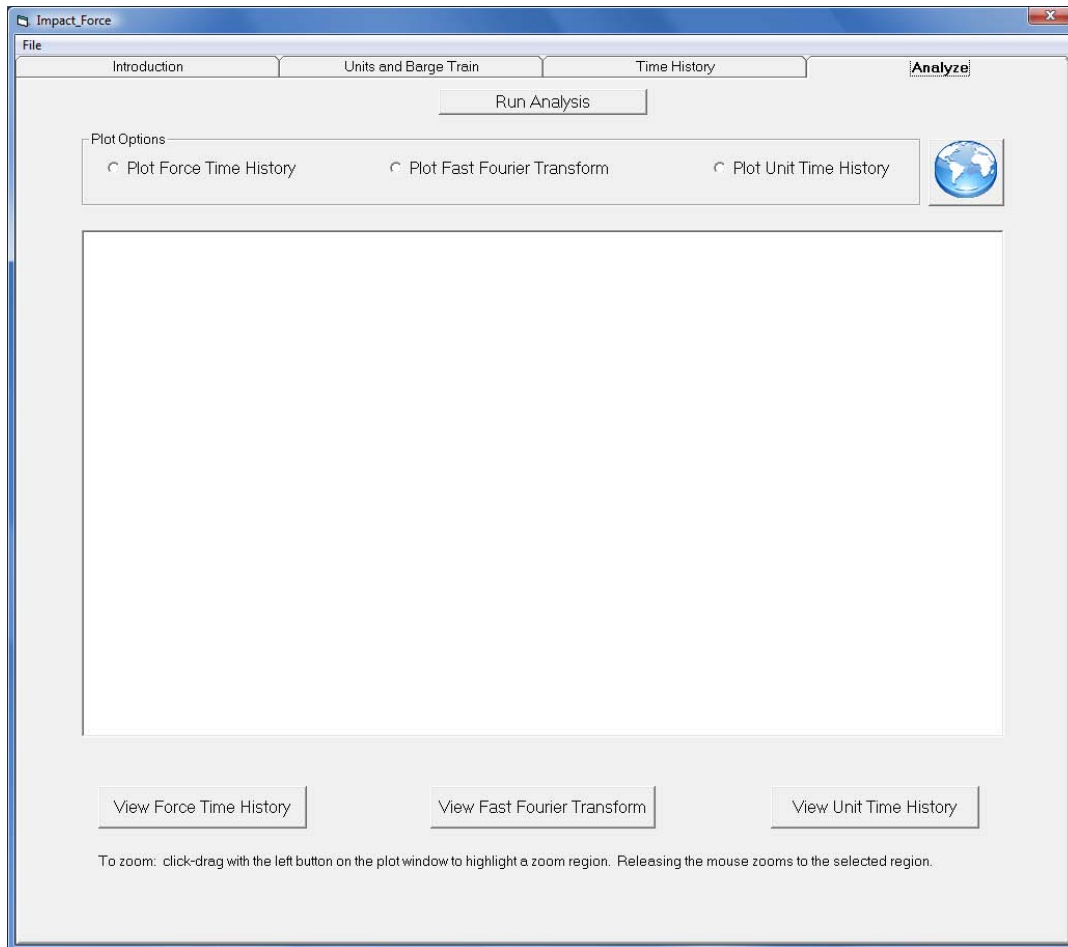

Figure 5.20. Plotting and Viewing Options Enabled.

By selecting any one of the plot options, a plot of the respective output file selected will be displayed in the picture box. Figure 5.21 shows an example of selecting the plot option, Plot Unit Time History. Observe that for the resulting unit force time history the maximum amplitude is unity.

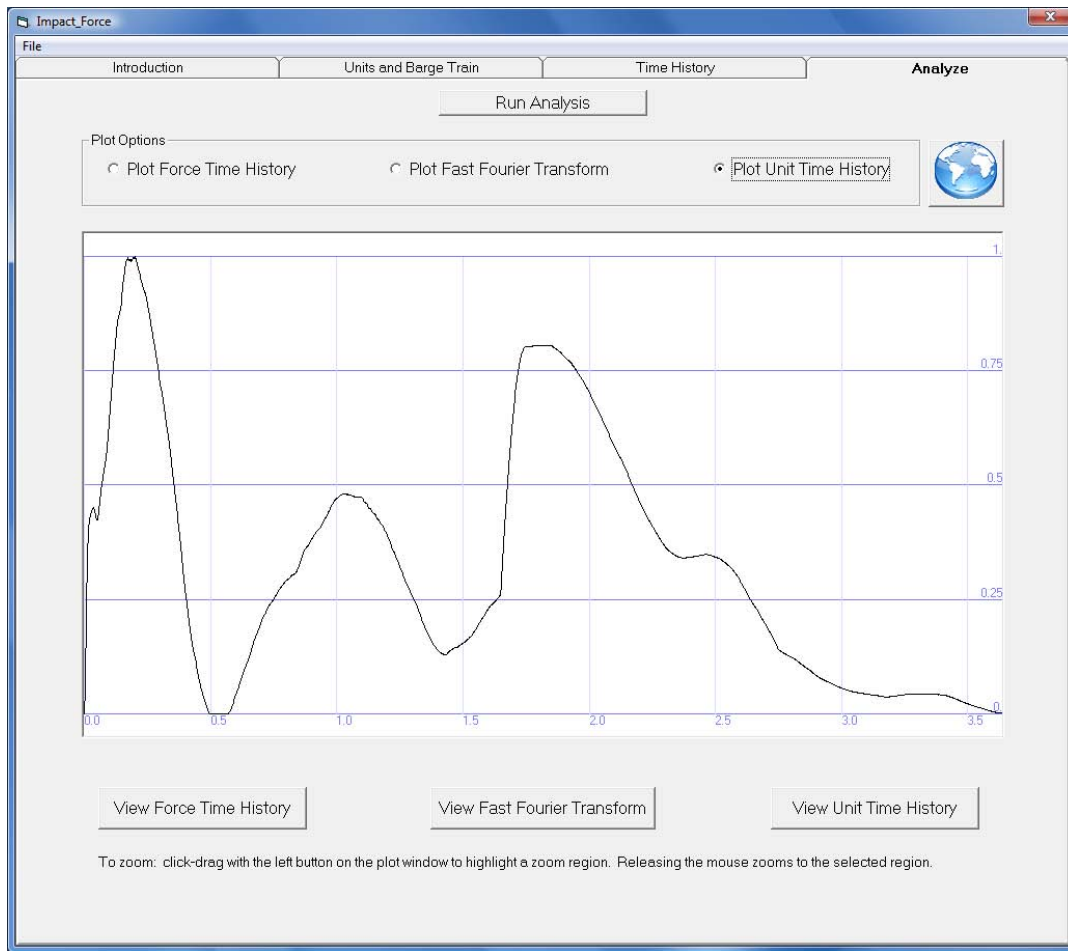

Figure 5.21. Plot of Unit Time History.

Also, by selecting any one of the view options, the contents of the respective output file selected will be displayed in a file viewer. Figure 5.22 shows a view of the unit time history output file once the “View Unit Time History” button has been pressed. The file viewer has a pull-down menu that gives the user the capability to save the output file or print the output file. By clicking File->Save As, the user can save the output file to a directory of their choice. Figure 5.23 shows the dialog that prompts the user to save the output file. Also, by clicking File->Print, the user can print the output file using the default printer. Clicking File->Finished or the top right-hand exit button will close the file viewer.

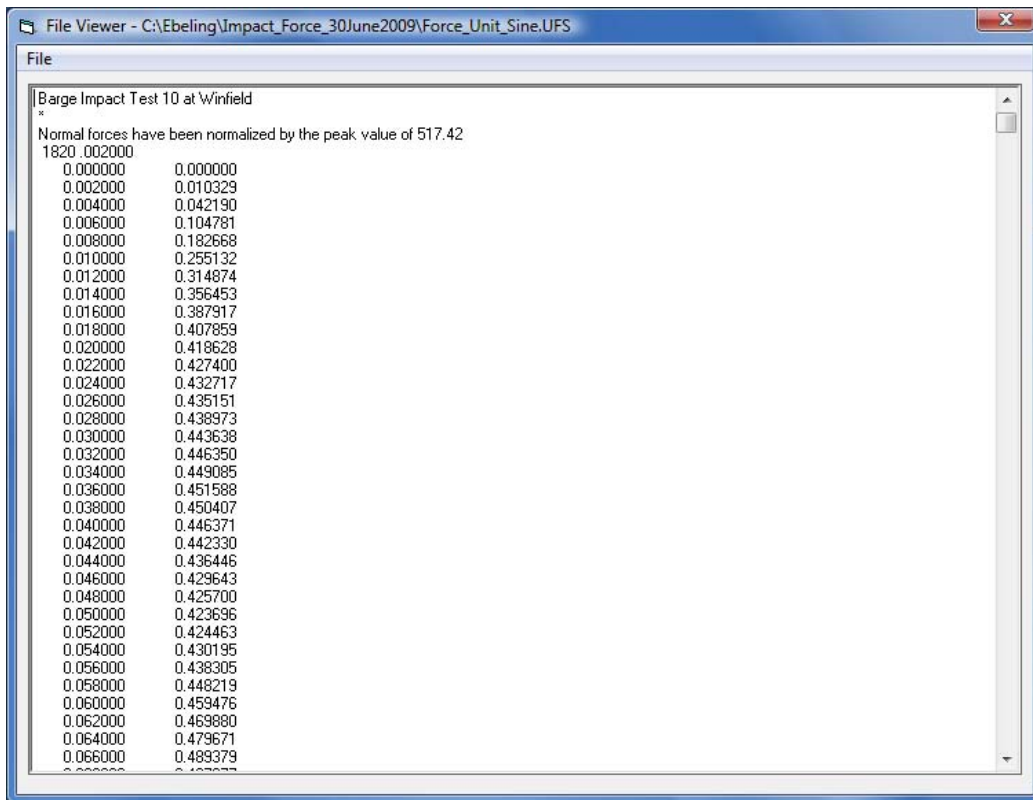

Figure 5.22. View of Unit Time History Plot File.

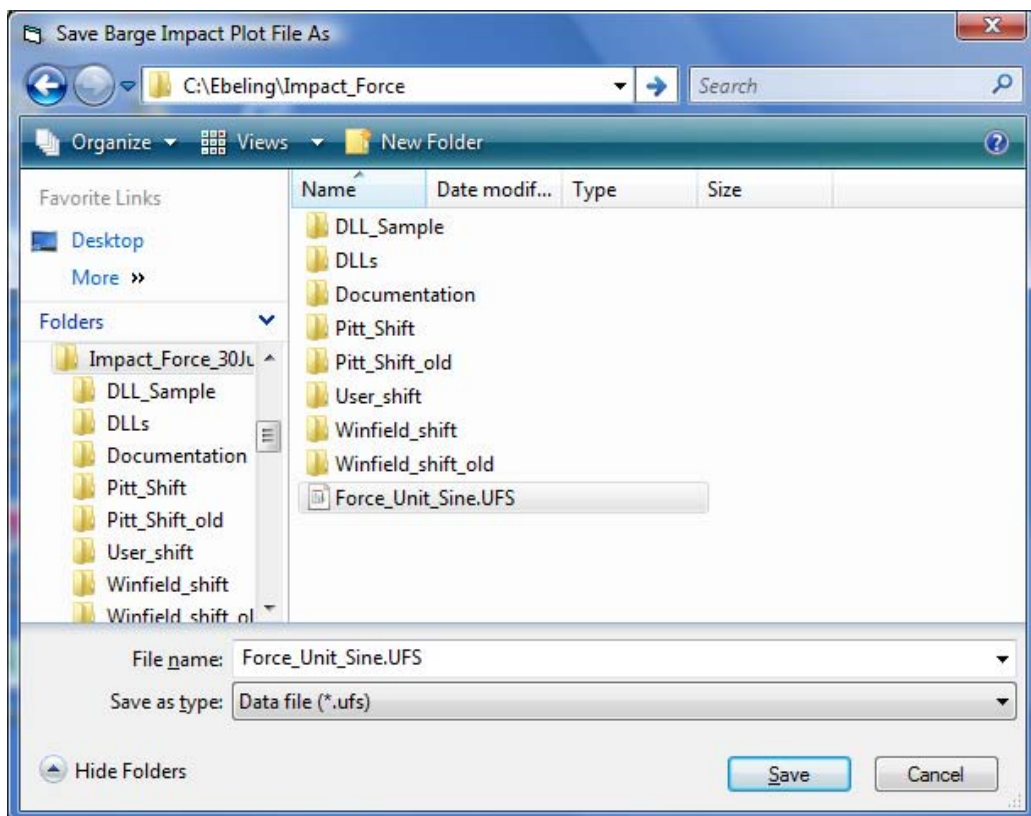

Figure 5.23. Save Barge Impact Plot dialog.

The Force Time-History plot is displayed below in Figure 5.24. This plot shows the scaled maximum force value (F-max) after applying the RMF value to the analysis. The F-max value can be found in an output file called Impact_Force.RUN, which is located in the application directory for Impact_Force. For example, if the application directory for Impact_Force is “C:\Impact_Force”, then the path would be “C:\Impact_Force\Impact_Force.RUN”. Figure 5.25 shows where the magnitude and time of the value for F-max can be found in Impact_Force.RUN.

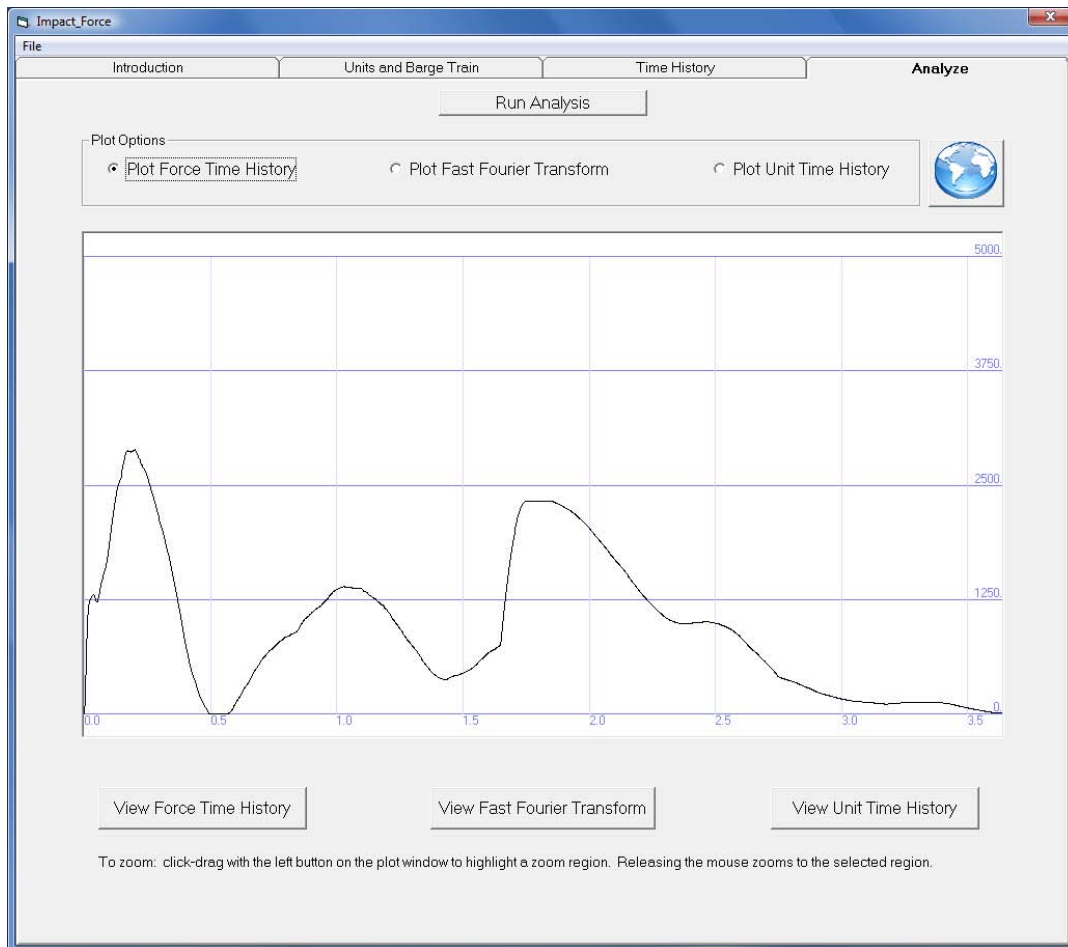

Figure 5.24. Plot of Force Time History.

```

Impact_Force.RUN - WordPad
File Edit View Insert Format Help

* Step 6: Compute the maximum amplitude of the pulse force time
history *

Maximum amplitude of the pulse force time history:
F-max =                2889.059797 kips
  for a
BT_linear_momentum_norm =    8776.7556 kips-sec
Unit_Area =                1.178716 kips-sec
Time =                    0.200000 secs

* FFT Analysis has been created *

*****
* FFT Analysis time history is in:  Force_FFT.FFT *
*****

*****
* Scaled force pulse time history is in:  Force.FRC *
*****

* Normal termination *

For Help, press F1

```

Figure 5.25. View of the Impact_Force.RUN file to locate F-Max.

5.5 Zoom capability

The Analyze tab offers the capability to zoom to a certain region of any plot. To zoom, the user must click and drag with the left mouse button on the plot window to highlight a zoom region. Releasing the mouse button causes the zoom region to be displayed in the plot window. Figure 5.26 displays a zoom region for the Fast Fourier Transform data. The default plot of the Fast Fourier Transform was primarily visible in the range of 1-2 Hz. This is an example in which the zoom capability can offer an improved view of the plot. If the user holds the mouse pointer over a point, the x and y coordinate for that point of interest will be displayed in a tool tip box. Notice that a peak occurs approximately at the frequency value of 1.25 Hz, which was specified by the user for the superimposed sine wave (Figure 5.12). While the plot is in the zoom state, the user can slide the

horizontal scroll bars along the x-axis to view the remaining portions of the plot. Pressing the global icon will return the plot to its default state. Figure 5.27 displays the default plot of the Fast Fourier Transform. Observe in both Figures 5.26 and 5.27 a Fourier amplitude for the near zero frequency, a long period wave form. It is artificial, introduced by a drift in the recording electronics (i.e., a DC underlying offset) at the Winfield impact tests. It is not inherent to the structural system and is to be ignored.

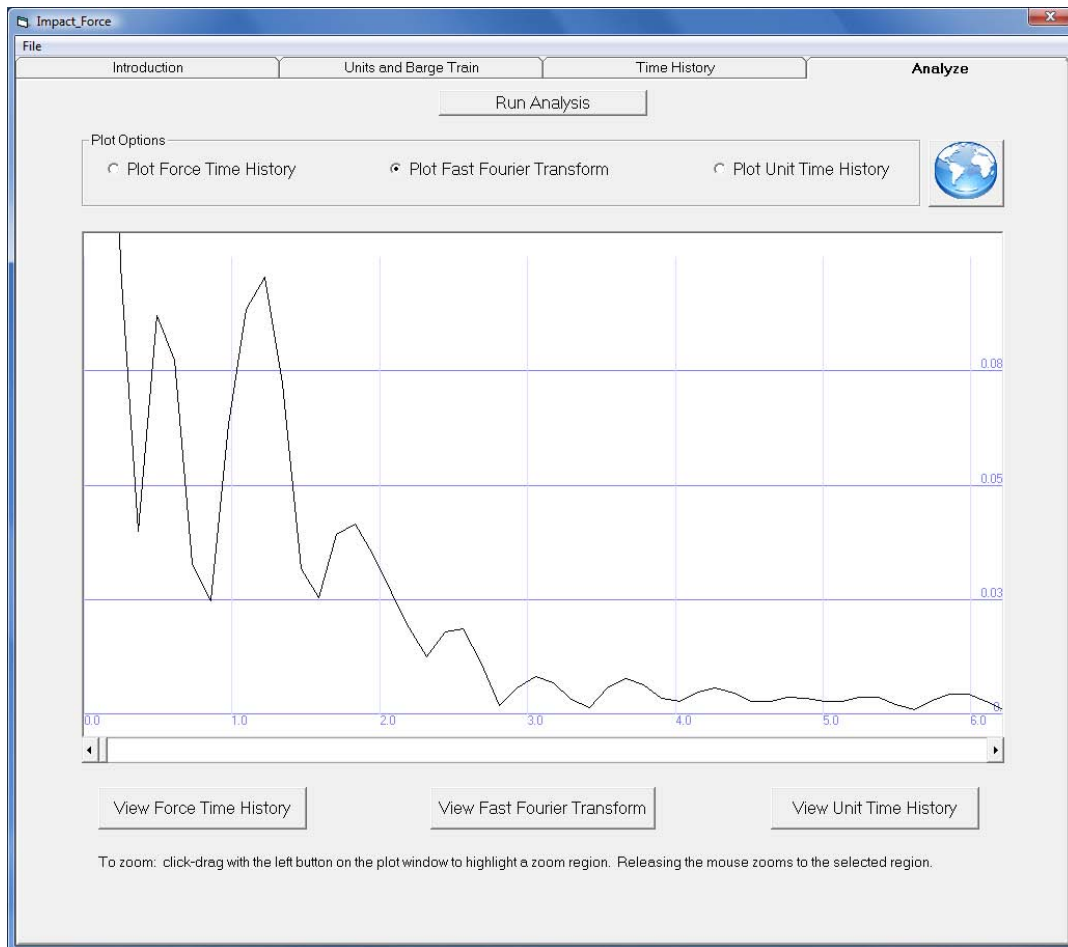

Figure 5.26. Zoom of Fast Fourier Transform Plot.

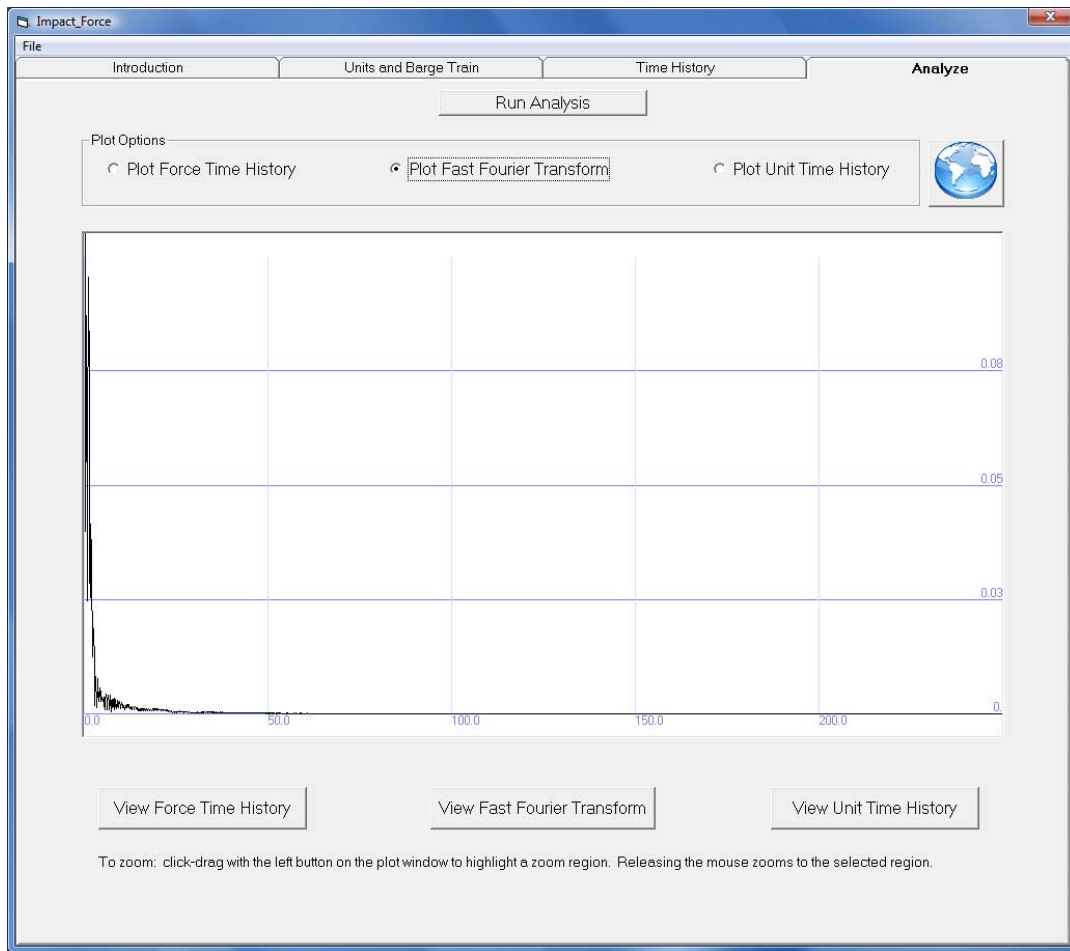

Figure 5.27. Default Plot of Fast Fourier Transform.

6 Summary, Conclusions, and Recommendations

6.1 Summary and conclusions

To conduct a dynamic structural response analysis of flexible approach walls at Corps locks using structural dynamics engineering computer programs, a pulse force time history is needed to represent the impact of a barge train with the approach wall. This technical report describes an engineering methodology used to emulate this (impact) pulse force time history normal to the wall with appropriate peak values and response. This engineering methodology is implemented within a PC-based FORTRAN program and visual modeler named `Impact_Force`.

Included in the R&D effort discussed in this report is the interpretation of the results from the 1997 full-scale barge train impact prototype experiments conducted at Old Lock and Dam 2 just north of Pittsburgh, PA, (Patev et al. 2003b) and of the 2008 full-scale barge train impact experiments conducted at Winfield Lock and Dam, Winfield, WV (Barker et al., in press). The 1997 full-scale tests are referred to as the Pittsburgh Prototype tests.

The engineering formulation for `Impact_Force` uses existing pulse data or synthetic pulse data and the impulse momentum principle to convert the linear momentum of a barge train into an appropriately scaled pulse force time history acting normal to the approach wall. Existing pulse data from Pittsburgh Prototype and Winfield full-scale field impact tests are made available for this Suite of PC-based software tools used in these pulse force time history creation efforts for use in dynamic structural response analyses.

The impulse and linear momentum normal to the impact beam for all of the full-scale Winfield test data were compared and the results summarized in Appendix A. An important discovery made during this evaluation of the 2008 Winfield field data (discussed in Chapter 2 and Appendix A or this report) revealed the need to moderate too-conservative

impulse linear momentum (Equation 2.12)¹ estimates with a constant response modification factor, RMF, defined as

$$\text{RMF} = \frac{\text{Impulse}}{\text{Momentum}} \quad (2.16 \text{ bis})$$

with

$$\text{Impulse} = \int_{t_1}^{t_2} \mathbf{F}_{\text{normal-wall}}(t) \cdot dt \quad (2.14 \text{ bis})$$

and

$$\text{Momentum} = m_{\text{barge train-normal}} \cdot (\mathbf{V}_{1\text{-normal}}) \quad (2.15 \text{ bis})$$

These impulse and momentum equations are idealized representations, not taking into account other impulse forces acting on the barge train, approximations for hydrodynamics via hydrodynamic added mass, adjustments of values assigned for the hydrodynamic added mass constants, etc..² Consequently, the RMF represents the difference between the single measured contact impact force results and the idealized momentum. Equation 2.12 provides the clue for determining the response modification factor. For the 2008 Winfield data, when the momentum of the barge train, determined by its mass and velocity (normal to the wall) per the left side of the equation, is not equivalent to the integral of the force time history (normal to the wall) then its likely that there are other outside forces affecting the momentum of the barge train. These outside forces can be accounted for by a scale factor applied to the momentum of the barge train, i.e., a response modification factor.

$$^1 m_{\text{barge train-normal}} \cdot (\mathbf{V}_{1\text{-normal}}) = \int_{t_1}^{t_2} \mathbf{F}_{\text{normal-wall}}(t) \cdot dt \quad (2.12 \text{ bis})$$

² Recall that fundamental to the engineering formulation used to develop the pulse force time history is the impulse momentum principle, which may be expressed normal to the wall as

$$m_{\text{barge train-normal}} \cdot (\mathbf{V}_{2\text{-normal}} - \mathbf{V}_{1\text{-normal}}) = \int_{t_1}^{t_2} \mathbf{F}(t) \cdot dt \quad (2.5 \text{ bis})$$

The key point is that $\mathbf{F}(t) = \underline{\text{all}}$ of the forces acting on the barge train and in the direction normal to the approach wall, including the reaction force of wall during barge train impact [designated $\mathbf{F}_{\text{normal-wall}}(t)$ in Figure 2.1].

$$m_{\text{barge train-normal}} \cdot (V_{1\text{-normal}}) \cdot \text{RMF} = \int_{t_1}^{t_2} F_{\text{normal-wall}}(t) \cdot dt \quad (2.13 \text{ bis})$$

Calculations in Appendix A for the complete set (19) of the 2008 Winfield full-scale test data indicates a mean (μ), standard deviation (σ) and coefficient of variation (COV) for the RMF value of $\mu = 0.397$, $\sigma = 0.047$, and $\text{COV} = 0.118$, respectively. The set of 15 2008 Winfield full-scale test data without possum indicates a mean (μ), standard deviation (σ) and coefficient of variation (COV) for the RMF value of $\mu = 0.396$, $\sigma = 0.052$, and $\text{COV} = 0.131$, respectively. These values imply that the idealized momentum equation of Equation 2.15 significantly overestimates the single contact impulse force time history that was measured at the contact face (of the impact beam) that is between the corner impact barge and the wall. Appendix A provides a table that shows all the variables that were used to compute the RMF for each test.

It is important to select an appropriate response modification factor for the location involved. Should the user specify a RMF equal to 1.0, the Winfield data would infer that this would result in a conservative impulse time history.

6.2 Recommendations for future research

This report describes an engineering methodology used to create this pulse force time history normal to the wall. It makes use of the pulse force time-history data recorded at the 2008 Winfield full-scale field impact tests and of pulse data strain gage data recorded on strain gages mounted at the bow impact corner of the front impact barge during the 1997 Pittsburgh Prototype tests. One recommendation is to expand the pulse time-history data base by mounting strain gages (transverse to the axis of the barge) at the impact corner of the lead barge of a ballasted barge train and record data during lock approaches.

A second recommendation is to further investigate the impulse linear momentum data of Winfield, to determine additional information that might help refine the constitutive equations. This will be the subject of research by this team after the impact beam strain gage and beam displacement data is processed and fully evaluated.

References

- American Association of State Highway and Transportation Officials. 1991. *Guide specification and commentary for vessel collision design of highway bridges, Volume 1: Final Report*.
- Arroyo, J. R., and R. M. Ebeling. 2006. Glancing-blow impact forces by a barge train on a lock approach wall. *ASCE Journal of Infrastructure Systems*.
- Arroyo, J. R., R. M. Ebeling, and B. C. Barker. 2003. *Analysis of impact loads from full-scale, low-velocity, controlled barge impact experiments, December 1998*. ERDC/ITL TR-03-03. Vicksburg, MS: U.S. Army Engineer Research and Development Center.
- Barker, B. C., R. M. Ebeling, C. E. Gray, R. W. Haskins, and T. W. Warren. (in press). *Barge impact experiments at Winfield Lock and Dam, Winfield, West Virginia*. ERDC/ITL-TR-09-XX. Vicksburg, MS: U.S. Army Engineer Research and Development Center.
- Headquarters, Department of the Army. 1993. (rescinded) *Barge impact analysis*. Engineer Technical Letter 1110-2-338. Washington, DC: U.S. Department of the Army.
- Headquarters, Department of the Army. 2004. *Barge impact analysis for rigid walls*. Engineer Technical Letter 1110-2-563. Washington, DC: U.S. Department of the Army.
- Patev, R. C., B. C. Barker, and L. V. Koestler. 2003a. *Full-scale barge impact experiments, Robert C. Byrd Lock and Dam, Gallipolis Ferry, West Virginia*. ERDC/ITL TR-03-7. Vicksburg, MS: U.S. Army Engineer Research and Development Center.
- Patev, R. C., B. C. Barker, and L. V. Koestler. 2003b. *Prototype barge impact experiments, Allegheny Lock and Dam 2, Pittsburgh, Pennsylvania*. ERDC/ITL TR-03-2. Vicksburg, MS: U.S. Army Engineer Research and Development Center.

Appendix A: Summary Statistics for Winfield Prototype Impact Tests

On the 25th and 26th of August 2008, a series of full-scale barge train impact experiments with a flexible approach lock wall were performed (Barker et al., in press). The series of barge train impacts consisted of twenty-three experiments conducted at the Winfield Lock and Dam at Red House, WV. Refer to Figure A.1 to see a view of the Winfield Lock and Dam and the site of the flexible guide wall used for impact testing. All experiments were conducted with a 3-by-3 barge train impacting a flexible approach guide wall. A force-measuring load-cell bumper was mounted to the corner of the barge. Figure A.2 shows the load-cell bumper mounted to the barge. The load-cell bumper measured the amount of force of the barge impacting the lock wall. There was no damage done to the lock wall; wall armor precluded surface damage and the impacts were kept below the usual design load case for the flexible impact beam. Figure A.3 shows a time-lapse overhead view of the impact corner of the impact barge and the load-cell bumper, through a data sampling cycle during the impact event. The procedure used and the extensive data recorded during these impact experiments is discussed in Barker et al. (in press). This Appendix focuses on only part of the recorded data; the force time histories recorded by the load cells and processed into the force time histories normal to the wall.



Figure A.1. Winfield Lock and Dam.



Figure A.2. Barge and load cell impact at target.



Figure A.3. Animated barge impact plot with bitt position.

Of the twenty-three impact experiments, only eighteen were considered to have a sufficient amount of recorded data that could be used for impact analysis. Additionally, four of these impact tests were performed using a “possum” placed between the lock wall face and the load cell bumper. A possum is a knotted section of rope covered with a nylon mesh, used to act as a “shock absorber” between the barge train and the approach wall. Impact angles of the barge ranged from 5 degrees to 20 degrees. Other barge information which includes the velocity, ranged from 0.5 to 2.5 mph (0.73 to 3.67 fps). Approximately 500 kips was the recorded maximum normal force of the barge impact. The maximum deflections that occurred at the mid-span of the wall were approximately 0.5 inches.

The data recorded for the Winfield Barge experiments was preprocessed for the Impact_Force GUI. Only time histories with forces above 1,000 lbs (i.e., 1 kip) were stored for the input files for the Impact_Force GUI. The duration of contact was computed by multiplying the total count of remaining time histories from preprocessing with the time step (0.002 second) of the data. Table A.1 summarizes the Winfield Barge Experiment field impact experiments.

A cross-section of the hollow, prestressed concrete impact beam is shown in Figure A.4. The impact beam is 10 feet wide and 8 feet high.¹

The impact face (sometimes referred to as the “front” face in this study) is the right face in this figure. Note that the armor to protect against gouging of the concrete by the lead impact barge during an approach is not shown in this figure. The long, flexible beam has a length of 117 feet 7 ³/₄ inches. The beam is simply supported at the ends (with no rotational constraints).

Displacement data for the beam recorded by Barker et al. (in press) shows that the beam clearly deflects during impact. The maximum deflection recorded during the twenty three impact tests was about 1/2 inch mid-span of the beam, occurring during Barge Impact Test number 10.

¹ The cross-sectional area has a measurement of 117 sq ft (16848 sq in.).

Table A.1. The angles and computed velocity, peak forces, and duration of impacts.

Test Name	Impact Angle (degrees)	Velocity (mph)	Normal Force		Duration of Contact (sec)	Time to Peak (sec)	Notes
			Max (lbs)	Min (lbs)			
BIloadTest1	6.68	0.73					
BIloadTest2	11.38	0.94					
BIloadTest3	11.78	0.97					
BIloadTest4	10.08	1.04					
BIloadTest5	19.38	0.88	344,295	140	3.566	0.187	
BIloadTest6	16.98	1.02	285,933	-260	3.584	0.186	
BIloadTest7	14.78	0.99	255,855	350	3.614	0.196	
BIloadTest8	9.58	2.02	297,200	640	3.616	0.182	
BIloadTest9	14.78	1.48	359,837	-344	3.484	0.172	
BIloadTest10	16.88	1.97	517,417	-234	3.64	0.2	
BIloadTest11	16.98	0.54	124,568	-198	3.906	0.218	
BIloadTest12	6.18	0.95	59,266	-210	3.506	0.236	
BIloadTest13	11.48	1.06	150,114	136	3.526	0.258	
BIloadTest14	9.08	0.98	111,053	-304	3.526	0.202	
BIloadTest15	14.58	1.03	235,270	-339	3.602	0.21	
BIloadTest16	9.18	2.45	355,033	-714	3.564	0.206	
BIloadTest17	15.28	0.97	226,071	-338	3.44	0.287	
BIloadTest18	16.88	1.44	406,060	-851	3.556	0.208	
BIloadTest19	18.78	1.47	281,442	-423	3.89	0.774	Possum used between wall and load cell bumper
BIloadTest20	13.58	1.87	411,443	-302	3.676	0.214	
BIloadTest21	11.28	1.9	327,295	-430	4.5	0.748	Possum used between wall and load cell bumper
BIloadTest22	14.1	1.06	134,189	-817	5.338	0.494	Possum used between wall and load cell bumper
BIloadTest23	14.38	1.96	300,143	-278	4.6	0.672	Possum used between wall and load cell bumper

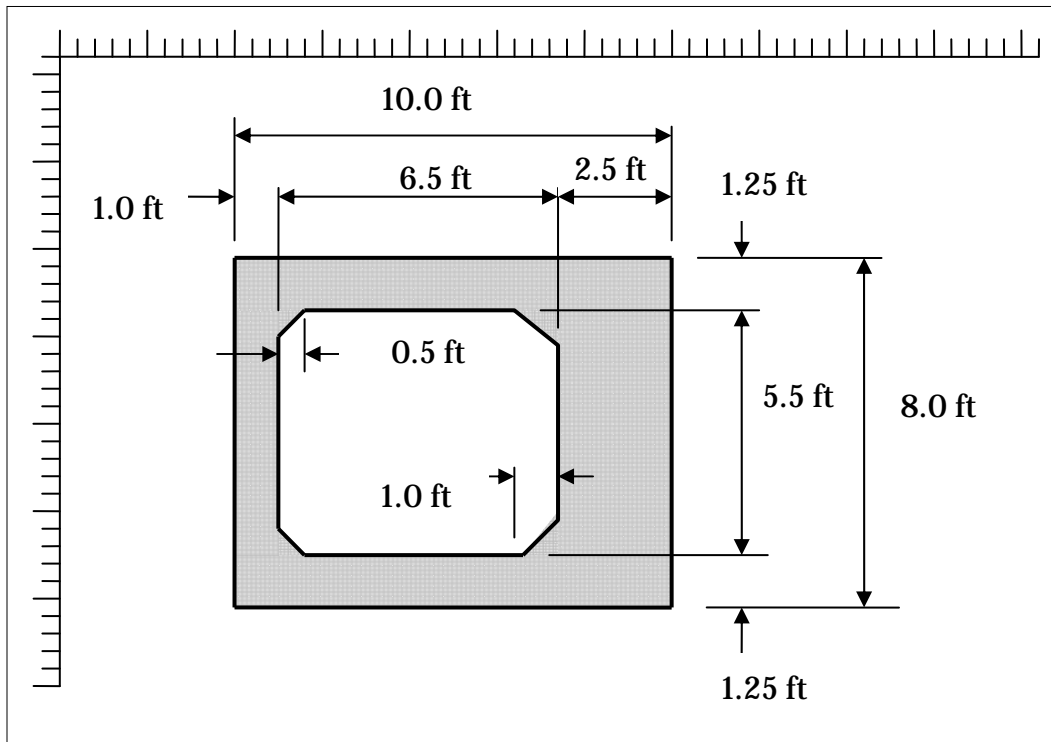

Figure A.4. The beam cross section of the lock approach wall.

Because the impact beam of the approach wall deflects during an impact, it is referred to as a flexible beam and wall. Additional gages were placed along the wall to determine strains and deflections of the wall during the impact events (Figure A.5). This figure also displays the total number of each of the major instruments mounted on the impact beam for this experiment. Interpretation of this data will be discussed in another report and involve the use of the PC-based software Impact_Beam.

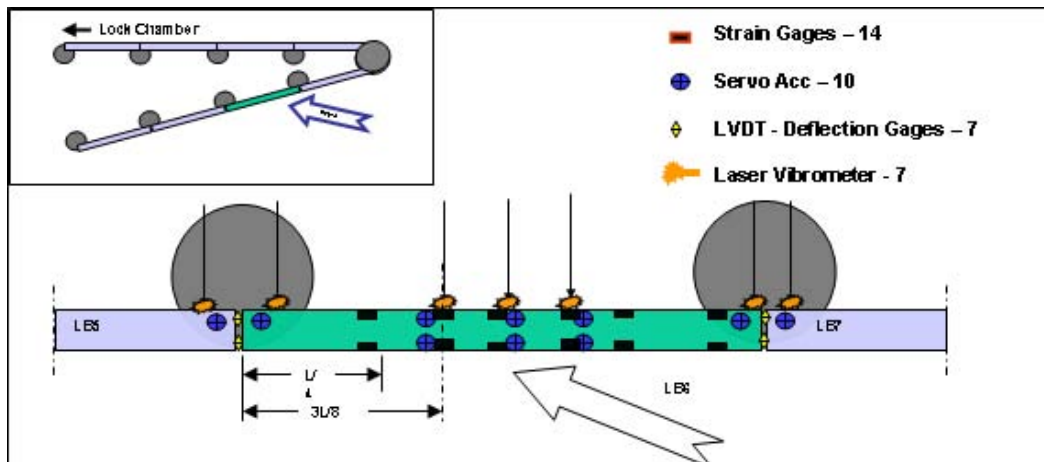

Figure A.5. displays all of the gage locations that were placed in the lock wall section.

The combined weight of each of the barge trains is the summation of the cargo weight and the barge weight. Table A.2 displays the combined weights for each individual barge used in the 3-by-3 barge train. The total weight of the barge train was 16,783 tons, including the weight of the helper boat. Figure A.6 displays the position of each barge in the barge train.

Table A.2. Individual barge and tow information.

Barge Weights			
Barge ID	Cargo (tons)	Barge (tons)	Combined (tons)
MEM 377	1704	332	2036
AEP 8808	1301	303	1604
AEP 8839	1385	303	1688
AEP 9327*	1586	354	1940
AEP 0737	1343	306	1649
AEP 0730	1359	306	1665
AEP 0749	1579	316	1895
AEP 0102	1579	316	1895
AEP 0631	1568	316	1884
Roger Keeney			507
Helper Boat			20

*Includes an additional 70 tons water ballast (estimated) needed to drop the nose of the impact barge 8 inches from added ballast

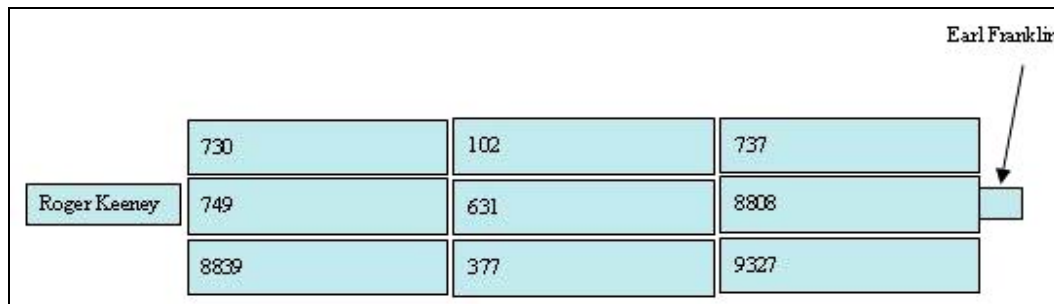

Figure A.6. Connected Barge Train.

For the Impact_Force program, the barge weight used for the Winfield time-history data was determined by computing the average barge weight. The Roger Keeney and the Helper Boat were excluded from the barge weight computation, because the summation of these two weights was specified as the tow weight.

The target point for the impact in these field tests is mid-span along the guide wall beam, identified in Figure A-1. Figure A-2 shows the target impact point identified with a yellow “X” marked on plywood for the tow boat captain to aim for. Figure A.7 shows the orientation of the impact beam and which direction is positive or negative with respect to this target point (mid-span of the impact beam). Table A.3 displays the barge impact orientation, velocity, and placement with respect to the target point on the wall for the twenty valid impact experiments.

Table A.3. Barge impact location of the lock wall.

Test Number	Angle of the Bow	Velocity		Location from Target (feet)
		ft/sec	mph	
Test 4	9.8	1.50	1.02	5.8
Test 5	13.3	1.13	0.77	6.4
Test 6	15.5	1.55	1.06	7.5
Test 7	20.2	1.53	1.04	9.7
Test 8	10.2	3.00	2.05	-18.9
Test 9	13.6	2.22	1.51	-9.7
Test 10	15.8	2.99	2.04	7.8
Test 11	6.9	0.80	0.55	35.8
Test 12	6.1	1.41	0.96	15.9
Test 13	10.2	1.50	1.02	5.6
Test 14	11.7	1.48	1.01	-15.2
Test 15	11.3	1.60	1.09	-26.2
Test 16	9.7	3.55	2.42	4.6
Test 17	21.2	1.44	0.98	3.8
Test 18	16.8	2.19	1.50	-18.0
Test 19	17.3	2.25	1.53	-12.7
Test 20	13.0	2.81	1.92	3.8
Test 21	13.0	2.80	1.91	4.5
Test 22	9.6	1.61	1.10	-25.1
Test 23	13.8	2.87	1.96	4.1

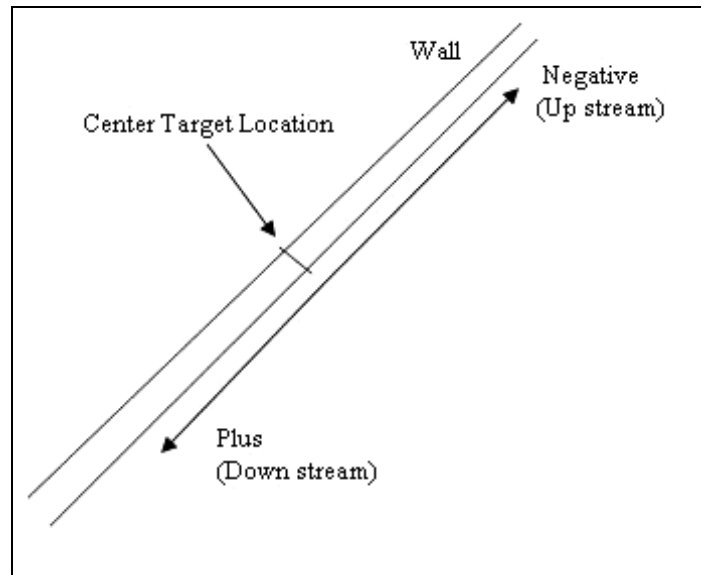

Figure A.7. A graphical representation of the target impact location of the lock wall.

Figure A.8 displays the impact time history normal to the approach wall for Barge Impact Experiment 10. This experiment recorded a maximum force of 517 kips. Four distinct pulses are also noticeable for Experiment 10. The first noticeable pulse occurs with the maximum peak of 517 kips. The second, third, and fourth noticeable pulses have peak values of approximately 232 kips, 139 kips, and 74 kips, respectively. This trend of decreasing amplitude pulses as the impact event proceeds is typical for the Winfield and Pittsburgh Prototype field impact tests.

Figure A.9 shows the Fourier transformation of the Figure A.8 normal force time history recorded during Barge Impact Experiment 10. The natural frequencies for this experiment are 1.22 Hz (0.82 second) and 3.42 Hz (0.29 second). The near zero frequency is a long period wave form. It is artificial, introduced by a drift in the recording electronics (i.e., a DC underlying offset). It is not inherent to the structural system and is to be ignored.

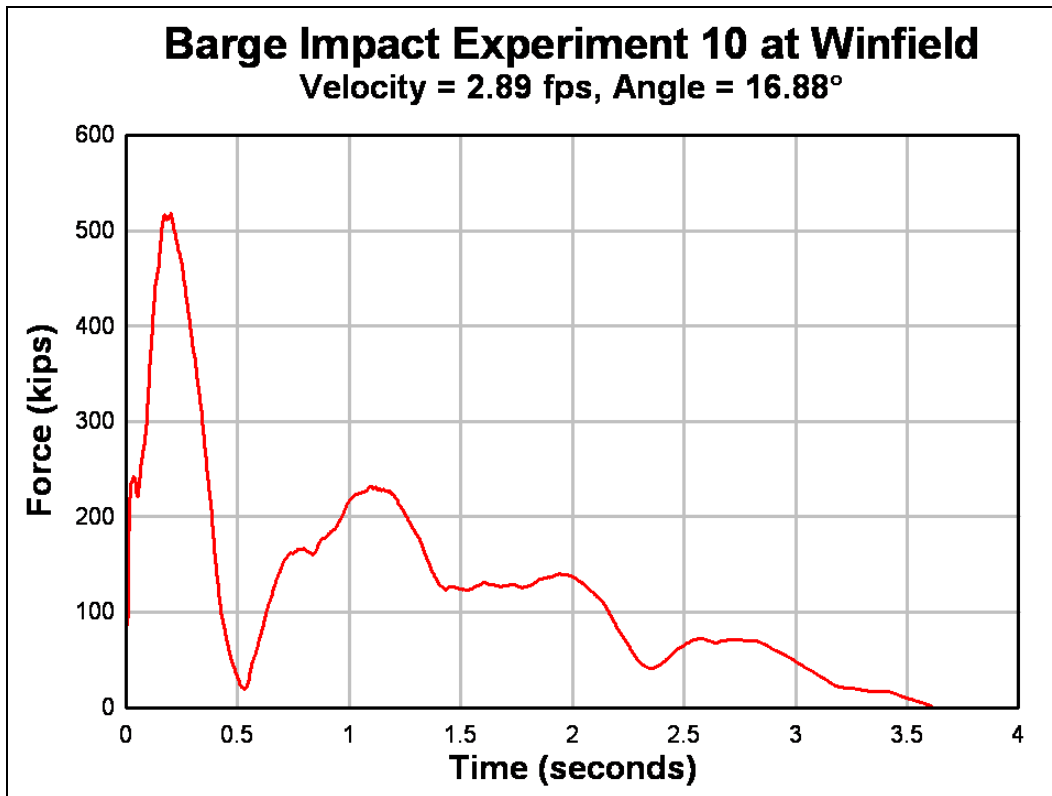

Figure A.8. Force time history normal to the impact beam for Winfield Experiment 10.

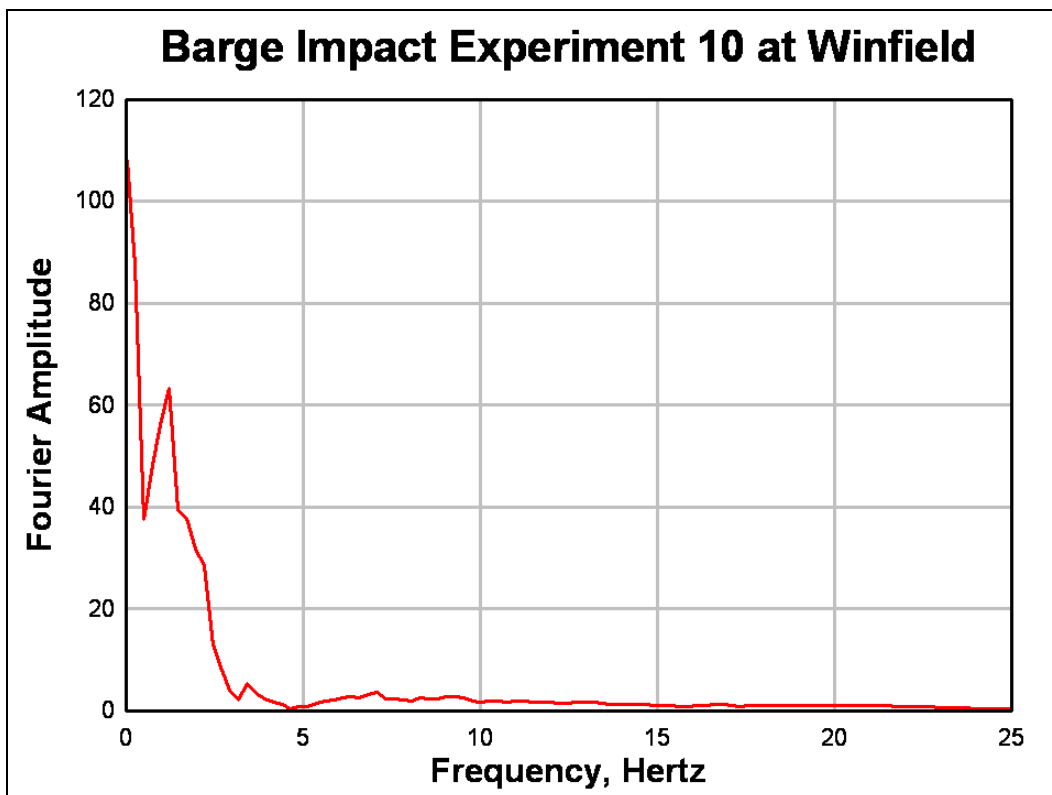

Figure A.9. Frequency Domain Plot of Winfield Experiment 10.

Figures A.10, A.11, and A.12 display the normal force time histories for different sets of impact experiments. Each experiment possesses two significant pulses followed by one or two less significant pulses. Note the force does not drop to zero magnitude between pulses; the barge train does not separate from the beam as the impact progresses. Also, note that each impact experiment experiences the same significant force value drop-off occurring after the first pulse that contains the maximum impact force for the impact.

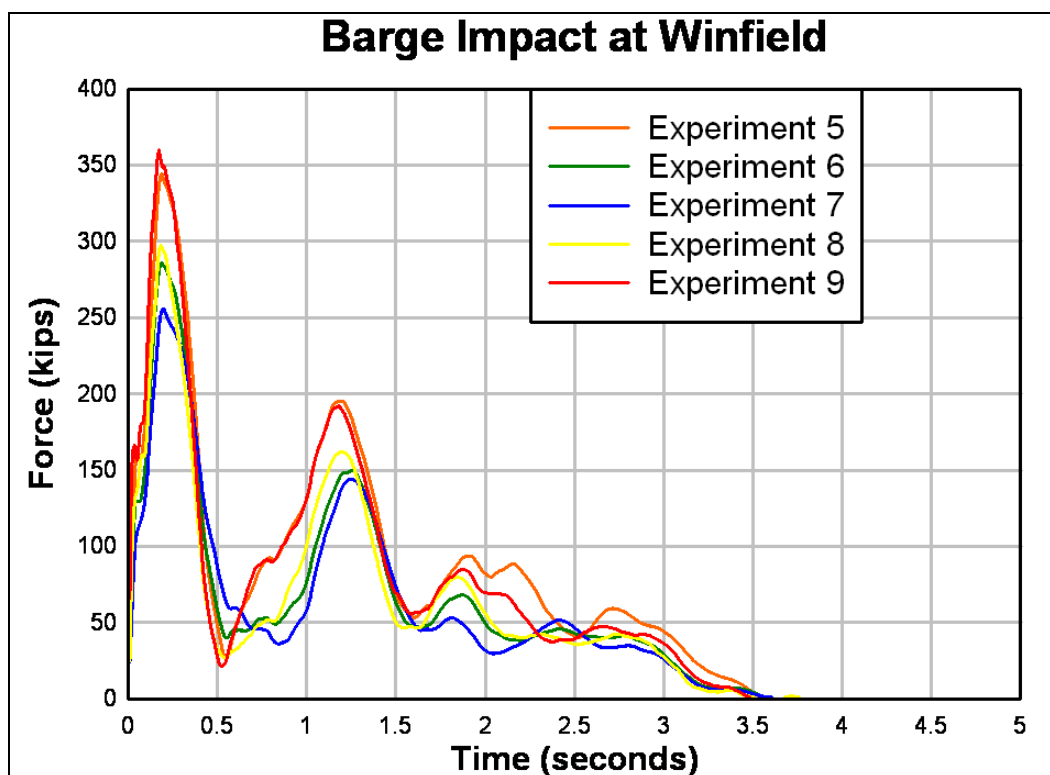

Figure A.10. Force Time Histories normal to the impact beam for Experiments 5, 6, 7, 8, and 9.

Figure A.13 shows the normal force time history when a “possum” is used between the lock wall and the load cell bumper. Figure A.14 shows the possum used in the experiments. The possum is a knotted section of rope covered with a nylon mesh and is used to act as a “shock absorber” between the barge train and the wall section. The time to peak was delayed, in comparison to the other experiments, due to the inclusion of the possum. In Barge Impact Experiment 19, the maximum peak actually occurred at the second pulse as opposed to the first pulse as observed in the other experiments (without a possum). According to Barker et al. (in press), the peak force in the time history is reduced but the impulse (i.e., area under the normal force time history) was preserved.

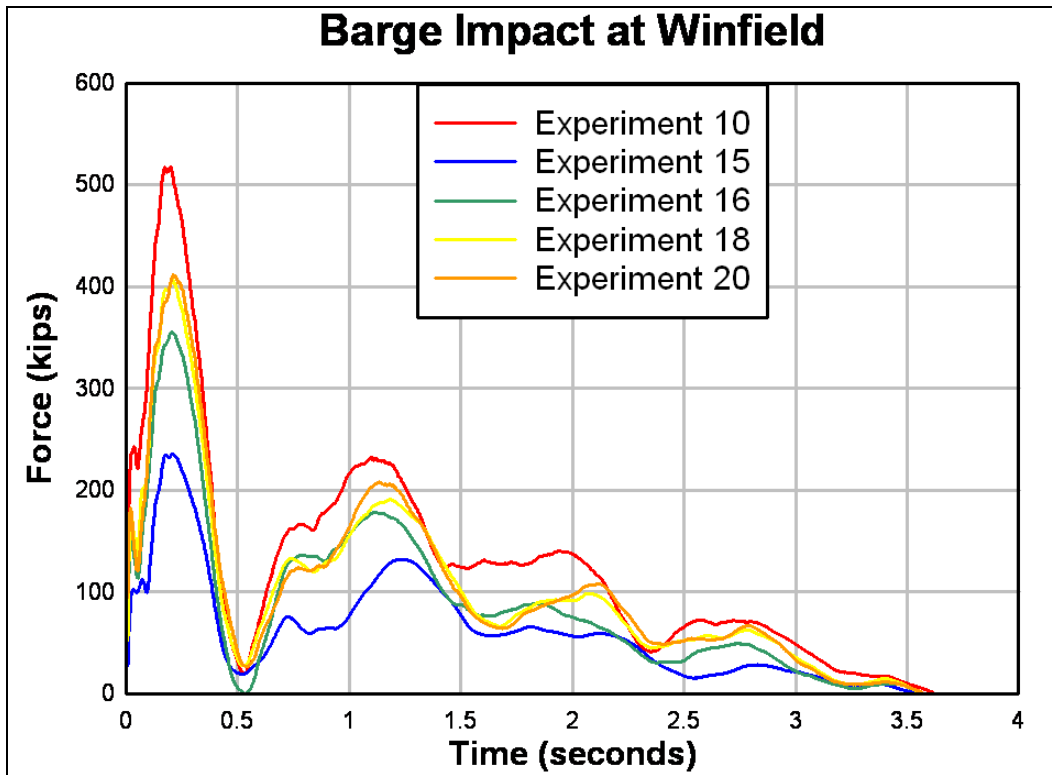

Figure A.11. Force Time Histories normal to the impact beam for Experiments 10, 15, 16, 18, and 20.

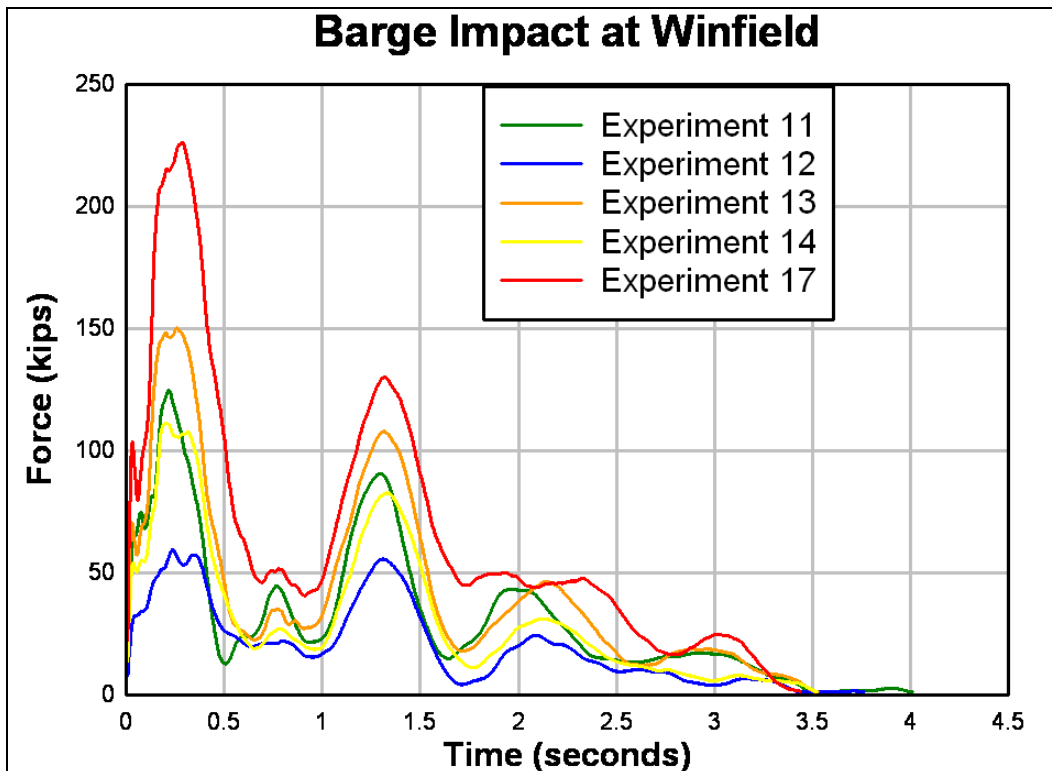

Figure A.12. Force Time Histories normal to the impact beam for Experiments 11, 12, 13, 14, and 17.

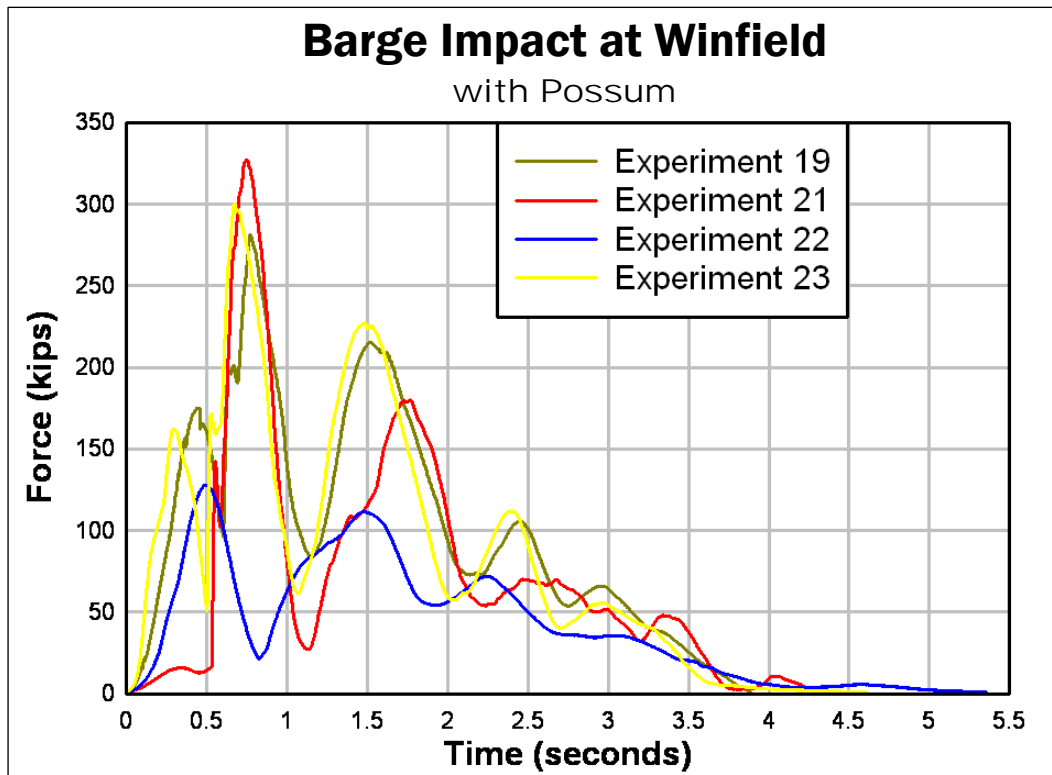

Figure A.13. Force Time Histories normal to the impact beam for Experiments 19, 21, 22, and 23 conducted with a possum.



Figure A.14. The "possum" used between the barge train with load cell and the wall.

Tables A.4, A.5, and A.6 display the data and the results of the intermediate computations used to determine the value for the Response Modification Factor (RMF) for each of the Winfield barge impact experiments. The unit area of the normalized time history ($\int F_{\text{unit}}(t) dt$), the approach angle (Θ), the mass of the barge train normal to the wall ($M_{\text{barge-normal}}$)¹, the approach velocity in the local barge X-direction (V_x), and the approach velocity normal to the wall (V_n) were all used to compute the RMF. The unit area of the normalized time history was computed by executing the Impact_Force program. After executing the Impact_Force program, the unit area value is written to an output file named Impact_Force.RUN. Refer to Figure 5.25 of Chapter 5 to see a view of the Impact_Force.RUN file. The approach angle and the approach velocity in the local barge X-direction is summarized in Table A.1. Notice that the approach velocity in Table A.1 is given in miles per hour (mph), which was converted to feet per second (fps) in Table A.4. The mass of the barge train normal to the wall was computed with Equation 2.1 of Chapter 2. Equation 2.1 is dependent upon the approach angle θ and the mass of the barge train in the local X direction and the mass of the barge train in the local Y direction, Equation 2.3 and Equation 2.4 of Chapter 2, respectively. Equations 2.3 and 2.4 are dependent upon the hydrodynamic added mass constant (1.05 for the local barge X direction and 1.4 for the local barge Y direction), the mass of the barge train, and the mass of the tow. The mass of the barge train was computed by taking the summation of the nine individual barge weights listed in Table A.2 and by dividing this summation by the gravitational constant of 32.174 ft/second². The mass of the tow boat was computed by taking the summation of the two tow barge weights listed in Table A.2, the Roger Keeney and the Helper Boat, and dividing this summation by the gravitational constant of 32.174 ft/second². Notice that the barge weights in Table A.2 is given in tons, but for this computation the barge weights were converted to kips. The approach velocity normal to the wall was computed with Equation 2.8 of Chapter 2, in which V_1 is the approach velocity in the local X direction, θ is the approach angle and β is set to 0. The maximum normal force (Normalization Factor) was provided by Table A.1. Notice that the Normalization Factor in Table A.1 is given in pounds (lbs), which was converted to kips in Table A.4. Refer to Section 2.8 of Chapter 2 for a detailed explanation of the computation of the RMF. In an effort to verify the results of these RMF computations using Impact_Force software, the product of the normalization factor and

¹ Including hydrodynamic added mass.

the unit area was computed; this is equal to the impulse normal to the wall. It was compared to the impulse determined by using the software Dplot¹ and with the original (normal) force time history provided as input. Both sets of computations resulted in the same value of impulse for each impact experiment; thus verifying the Impact_Force software and these RMF computations. Calculations are summarized in Tables A.5 and A.6. Tables A.7, A.8, and A.9 display the average RMF, the standard deviation RMF, and the coefficient of variation RMF, respectively, for all Barge Impact tests; Barge Impact tests 5 through 18 and 20 without a possum; and for tests 19 and 21 through 23 that possess a possum.

Table A.4. Data used to compute Response Modification Factor (RMF) Part I.

Test No.	$\int F_{\text{unit}}(t) dt$ (Normalized)	Θ (degrees)	$M_{\text{barge-normal}}$ (kips*sec ²)/ft	V_x (fps)	V_n (fps)	$M_{\text{barge-normal}} * V_n$ (kips*sec)
5	0.955	19.38	1408.858	1.291	0.428	602.991224
6	0.876	16.98	1420.195	1.496	0.437	620.625215
7	0.916	14.78	1429.557	1.452	0.371	530.365647
8	0.838	9.58	1447.208	2.963	0.493	713.473544
9	0.854	14.78	1429.557	2.171	0.554	791.974578
10	0.894	16.88	1420.642	2.89	0.839	1191.918638
11	0.99	16.98	1420.195	0.792	0.231	328.065045
12	1.236	6.18	1454.949	1.394	0.15	218.24235
13	1.02	11.48	1441.536	1.555	0.309	445.434624
14	1.01	9.08	1448.544	1.438	0.227	328.819488
15	0.937	14.58	1430.356	1.511	0.38	543.53528
16	0.886	9.18	1448.282	3.594	0.573	829.865586
17	0.994	15.28	1427.521	1.423	0.375	535.320375
18	0.895	16.88	1420.642	2.112	0.613	870.853546
19	1.42	18.78	1411.795	2.156	0.694	979.78573
20	0.902	13.58	1434.212	2.743	0.644	923.632528
21	0.954	11.28	1442.177	2.787	0.545	785.986465
22	1.71	14.1	1432.236	1.555	0.379	542.817444
23	1.29	14.38	1431.146	2.875	0.714	1021.838244

¹ D. W. Hyde, Dplot Graphic Software, HydeSoft Computing LLC, Vicksburg, MS.

Table A.5. Data used to compute Response Modification Factor (RMF) Part II.

Test No.	Normalization Factor (F_{Max}) (kips)	$\int F_{unit}(t) dt$ (Normalized)	Norm. Factor * $\int F_{unit}(t) dt$ (Calculated) (kips*sec)	Notes
5	344.3	0.955	328.807	
6	285.93	0.876	250.475	
7	255.85	0.916	234.359	
8	297.2	0.838	249.054	
9	359.84	0.854	307.303	
10	517.42	0.894	462.573	
11	124.57	0.99	123.324	
12	59.27	1.236	73.258	
13	150.11	1.02	153.112	
14	111.05	1.01	112.161	
15	235.27	0.937	220.448	
16	355.03	0.886	314.557	
17	226.07	0.994	224.714	
18	406.06	0.895	363.424	
19	281.44	1.42	399.645	with Possum
20	411.44	0.902	371.119	
21	327.3	0.954	312.244	with Possum
22	134.19	1.71	229.465	with Possum
23	300.14	1.29	387.181	with Possum

Table A.6. Data used to compute Response Modification Factor (RMF) Part III

Test No.	Impulse Norm. Factor * $\int F_{unit}(t) dt$ (Calculated) (kips*sec)	Momentum $M_{barge-normal} * V_n$ (kips*sec)	RMF (Eq. 2.16)	Notes
5	328.807	602.991224	0.545	
6	250.475	620.625215	0.404	
7	234.359	530.365647	0.442	
8	249.054	713.473544	0.349	
9	307.303	791.974578	0.388	
10	462.573	1191.918638	0.388	
11	123.324	328.065045	0.376	
12	73.258	218.24235	0.336	
13	153.112	445.434624	0.344	
14	112.161	328.819488	0.341	
15	220.448	543.53528	0.406	
16	314.557	829.865586	0.379	

Test No.	Impulse Norm. Factor * $\int F_{unit}(t) dt$ (Calculated) (kips*sec)	Momentum $M_{barge-normal} * V_n$ (kips*sec)	RMF (Eq. 2.16)	Notes
17	224.714	535.320375	0.42	
18	363.424	870.853546	0.417	
19	399.645	979.78573	0.408	with Possum
20	371.119	923.632528	0.402	
21	312.244	785.986465	0.397	with Possum
22	229.465	542.817444	0.423	with Possum
23	387.181	1021.838244	0.379	with Possum

Table A.7. Average RMF of all experiments, experiments performed without a possum, and experiments performed with a possum.

Average RMF		
All	No Possum	Possum
0.397	0.396	0.402

Table A.8. Standard Deviation RMF of all experiments, experiments performed without a possum, and experiments performed with a possum.

Standard Deviation RMF		
All	No Possum	Possum
0.047	0.052	0.019

Table A.9. Coefficient of Variation RMF of all experiments, experiments performed without a possum, and experiments performed with a possum.

Coefficient of Variation RMF		
All	No Possum	Possum
0.118	0.131	0.047

It is recommended that these scale factors be applied to computations in Impact_Force based on the Winfield data.

Appendix B: Summary Statistics for Pittsburgh Prototype Impact Tests

B.1 Introduction

In August of 1997 and December of 1998 two landmark series of full-scale barge train impact experiments with stiff-to-rigid lock walls were conducted. The first series of tests, referred to as prototype experiments, conducted at Old Lock and Dam 2 just north of Pittsburgh, PA. The results of these first series of full-scale impact experiments are discussed in Patev et al. (2003b) for a 2-by-2 ballasted barge train impacting a stiff-to-rigid wall. The second series of full-scale barge train impact experiments with a stiff-to-rigid lock wall was conducted at the now decommissioned Old Gallipolis Locks at Gallipolis Ferry, WV. Patev et al. (2003a) discuss this second series of full-scale impact experiments and Arroyo et al. (2003) describe the interpretation of this data.

To correctly interpret the strain data collected in the Pittsburgh Prototype Impact Test, it is necessary to discuss the relationships between the strain gage collection of data at Pittsburgh and the force data collected at Old Gallipolis. A discussion of the collection of data at Old Gallipolis is given next and correlations are drawn between the strain data collected at Pittsburgh and force data collected at Old Gallipolis.

B.1.1 Strain Gage Data Comparison from Old Gallipolis Locks Impact Test

During the second full-scale impact tests conducted at Old Gallipolis Locks, a 3-by-5 barge train fully ballasted with anthracite coal and with an instrumented load cell bumper attached to the front barge impact corner was used to record the impact force pulses with the stiff-to-rigid wall during these experiments. Figure B.1 shows the impact force versus time for Experiment 30, as interpreted from the field test data by Arroyo et al. (2003).

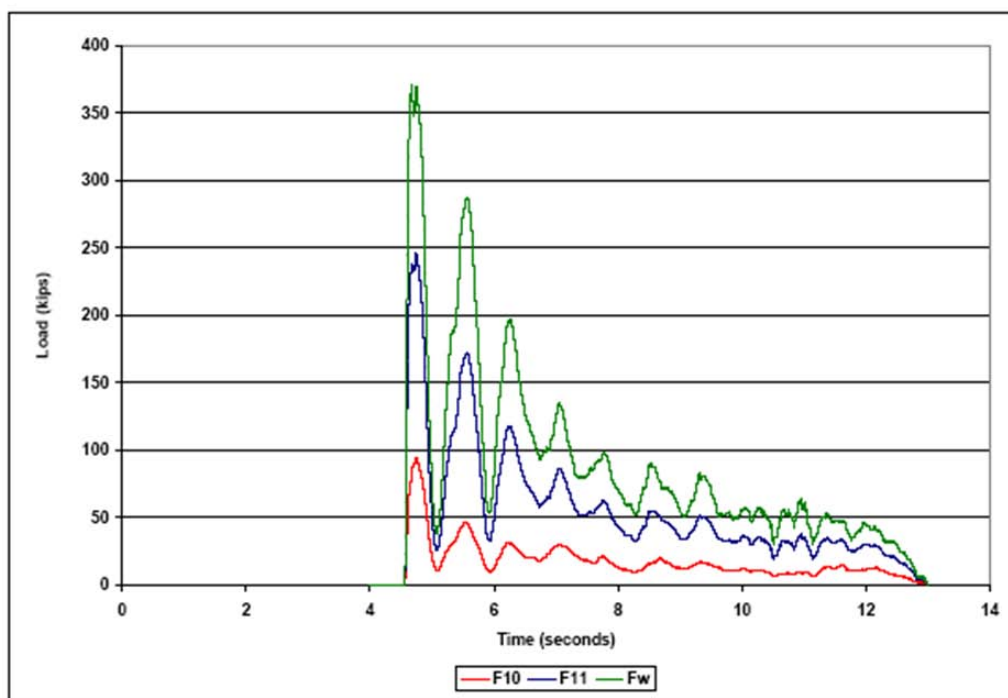

Figure B.1. Load cell forces F10, F11, and the interpreted force normal to the wall Fw for Experiment 30 (from Arroyo et al. 2003).

The maximum force normal to the wall Fw was 369 kips in Experiment 30 and occurred 0.1796 second after impact (Table B.2 of Arroyo et al. 2003). The barge train was in contact with the wall for about 9 seconds (Table B.2 in Arroyo et al. 2003). It is important to note that during this full-scale impact tests at Old Gallipolis Locks, a helper boat was used at the bow of the barge train to maintain contact with the wall for the entire 9 seconds. The helper boat held the impact corner of the 3-by-5 barge train against the decommissioned lock wall to help slow it down. Note that continuous contact with the wall is reflected in the non-zero Fw values throughout the Figure B.1 time history. Thus shortly after initial contact with the approach wall, the recorded pulse force time histories are not considered representative of a barge train approach into a lock. An essential observation from the results of this experiment and the other seven relevant experiments was the initial pulse time to maximum impact force, which occurred, on average, 0.17 second after initial impact (0.04 second standard deviation; ranges from 0.13 to 0.24 seconds). These eight impact experiment results were used to develop the empirical correlation shown in; Figure 6.3 of Arroyo et al. (2003); Figure E-2 in ETL 1110-2-563 (Headquarters, Department of the Army 2004); and in Figure 8 in Arroyo and Ebeling (2006).

Figure B.2 shows the maximum force normal to the wall F_w during Experiment 29 was 287 kips, which occurred 0.1282 second after impact and that the barge train was in contact with the wall for about 9 seconds (Table B.2 in Arroyo et al. 2003).

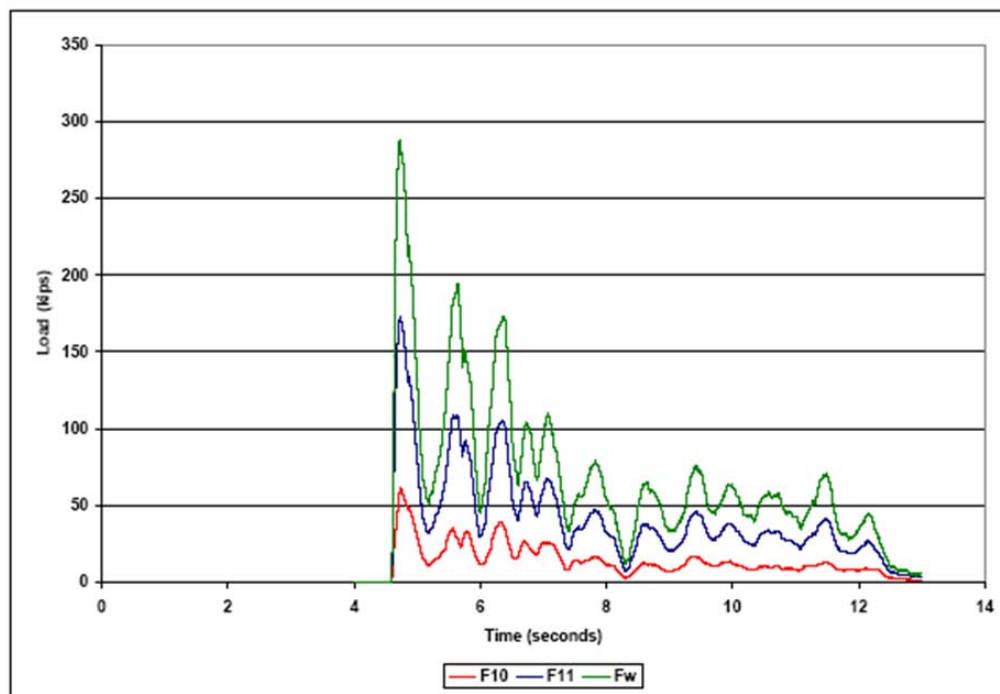

Figure B.2. Load cell forces F10, F11 and the interpreted force normal to the wall F_w for Experiment 29 (from Arroyo et al. 2003).

Other instrumentation data recorded during the second full-scale impact test conducted at Old Gallipolis Locks included strain gage data recorded by strain gages mounted near the impact corner of the deck plate of the lead barge that impacts the decommissioned lock approach wall. Overlay plots of the strain pulse time history parallel to the bow of the barge and the impact bumper load cell F11 time history recorded at the impact corner of the front barge showed the plots of strain versus time mirrored the plots of force versus time, as exemplified by the Figure B.3 overlay plot for Experiment 29. The rise and fall in the amplitudes for the two curves in this figure approximately mirror each other for the two time-history plots. That is, the rise impact force time history reflects the rise in the compression strain in the deck plate during impact as shown in Figure B.3 for the F11 load cell and strain gage data. Similarly, the fall in the impact force mirrors the drop off in compression strain of the strain gage through the time history of impact. Observe the ratio of load to strain had a slight fluctuation for the 9 seconds of impact in Experiment 29 but is interpreted

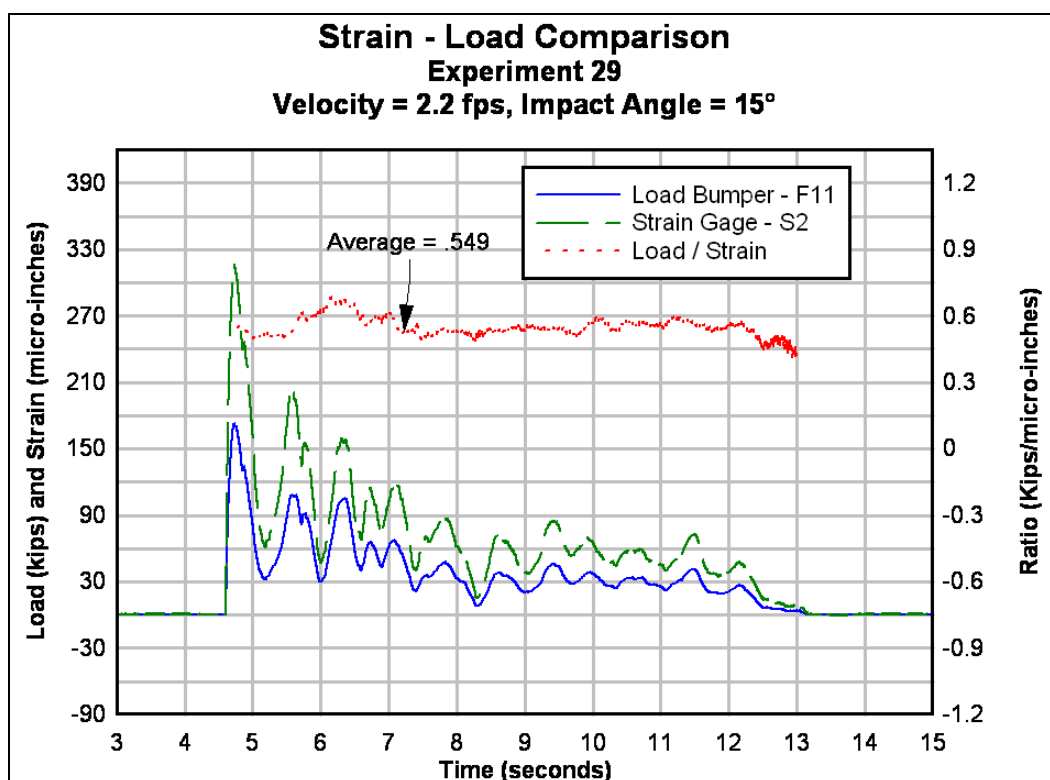

Figure B.3. 1 Load cell force F11, Strain Gage S2 and their ratio for Experiment 29.

as a relative stable ratio, averaging 0.549. This feature allows for the interpretation the strain gage data recorded during the first impact tests, the prototype tests, as if the (compression) strain pulses were the force pulse. The impact beam with instrumented load cells had not yet been fabricated at the time of the Pittsburgh prototype tests. Consequently, only the strain gage time-history data from the strain gages mounted on the deck plate at the impact corner of the lead barge was available for use in this study.

The remainder of this Appendix describes the interpretation of strain gage time-history data recorded by Patev et al. (2003b) during the prototype tests conducted at Old Lock and Dam 2. A series of 36 full-scale impact experiments were conducted using a ballasted 2-by-2 barge train pushed by tow. Test numbers 8 through 25 recorded during impacts with the stiff-to-rigid wall at Old Lock and Dam 2 were interpreted for characterization of pulse amplitudes and time sequencing. Strain gage time-history data recorded on the deck plate of the barge impact corner reflect the pulse (force) time history during impact, as discussed the previous paragraph. All strain gage time histories start at 1.0 second in the time-history plots presented in this appendix.

B.2 Pittsburgh Prototype Input Test Strain Gage Data

Figure B.4 shows the strain time history recorded by the strain gage SY-1 oriented parallel with the bow and mounted close to the impact corner on the deck plate in Experiment 8. Observe there are four distinct pulses over the 2.83 seconds of contact and that during the time between the third and fourth pulses, the barge train is not in contact with the wall. Observe that the largest amplitude of compression strain, and thus impact force, occurs during the first pulse. This is consistent with the force and strain time histories recorded during the impact tests conducted at Old Gallipolis Locks (Arroyo et al. 2003). There is a fifth pulse starting at a time of 7 seconds in Figure B.4 and is considered to be a later hit. This pulse is not included in this processing. The time to peak (first) pulse, Δt_{peak} , is 0.111 second. The duration of the pulses one through four are 0.415 second, 0.59 second, 0.58 second, and 0.26 second, respectively. The maximum amplitude of pulses one through four, normalized by the amplitude of pulse one are; 1.0, 0.8, 0.43, and 0.21, respectively.

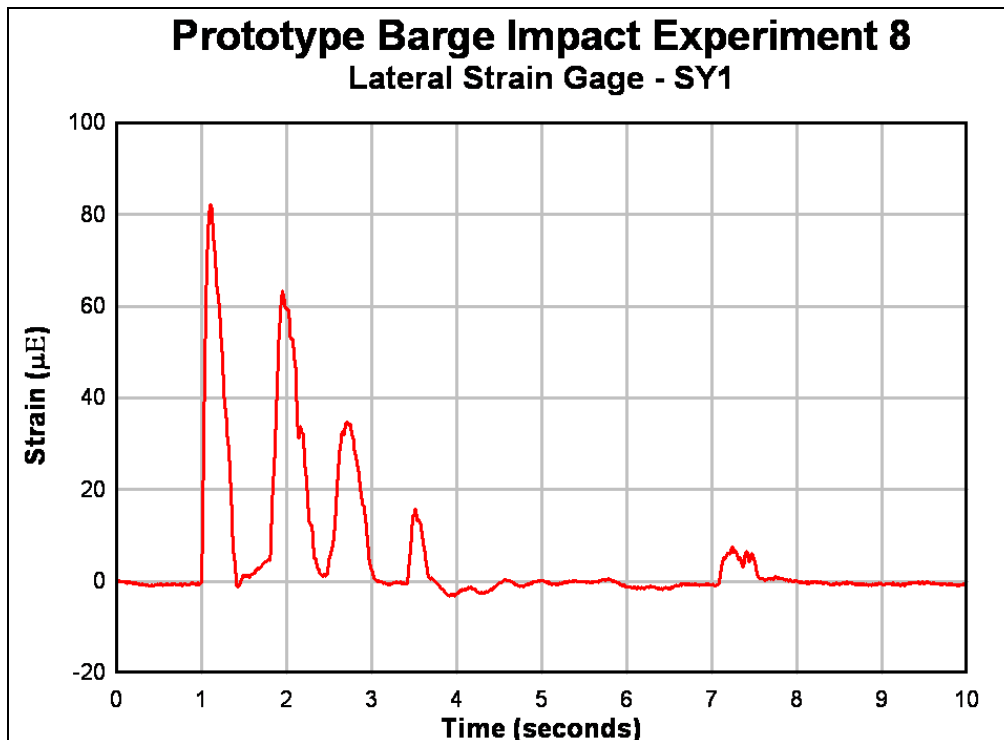

Figure B.4. Lateral Strain Gage SY1 (Channel 12) time history in the transverse direction on the deck plate for Experiment 8.

For the 18 strain gage time histories recorded on the impact corner deck plate and discussed in this appendix, the number of distinct pulses occurring during the primary hit with the stiff-to-rigid wall at Old Lock

and Dam 2 just north of Pittsburgh, PA varies between three and five. Table B.1 shows that all eighteen strain gage time histories contain three pulses and that the majority of these primary pulses (i.e., 16 of the 18) contain four pulses.

Table B.1 Summary of the number of pulses recorded in Lateral Strain Gage SY1 (Channel 12) for eighteen barge impact experiments.

No. of Impact Experiments with 3 pulses	No. of Impact Experiments with 4 pulses	No. of Impact Experiments with 5 pulses
2	13	3

Figure B.5 shows the Fourier transformation of the strain gage parallel to the bow of the barge recorded during Experiment 8. The natural frequencies for the first five modes are 1.24 Hz, 1.98 Hz, 2.48 Hz, 3.31 Hz, 3.8 Hz, and 4.5 Hz, respectively. The near zero frequency is a long period wave form. It is artificial, introduced by a drift in the recording electronics (i.e., a DC underlying offset). It is not inherent to the structural system and is to be ignored.

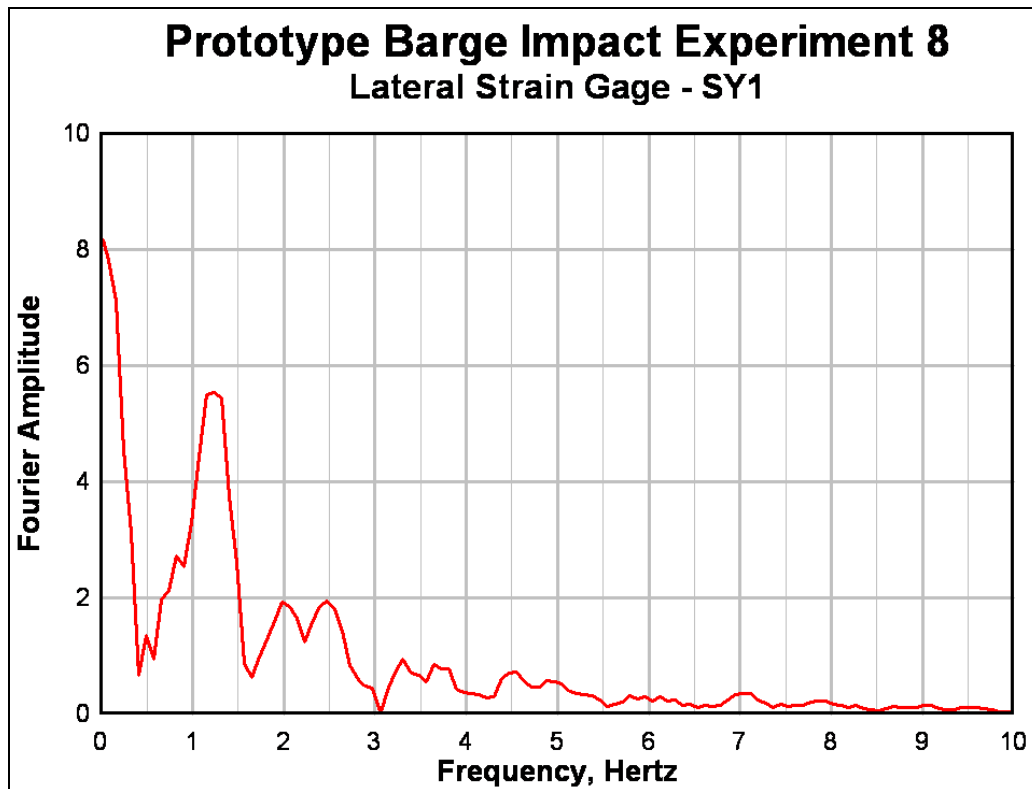

Figure B.5. Fourier Transformation of the Lateral Strain Gage SY1 (Channel 12) time history in the transverse direction on the deck plate for Experiment 8.

Figure B.6 shows the strain time history recorded by the strain gage oriented parallel with the bow and mounted close to the impact corner on the deck plate in Experiment 24. Observe there are four distinct pulses over the 3.51 seconds of contact and that during the time between each of the pulses, the barge train is not in contact with the wall. Observe that the largest amplitude of compression strain, and thus impact force, occurs during the first pulse. This is consistent with the force and strain time histories recorded during the impact tests conducted at Old Gallipolis Locks (Arroyo et al. 2003). The time to peak pulse, Δt_{peak} , is 0.117 second. The duration of the pulses one through four are 0.428 second, 0.481 second, 0.554 second, and 0.262 second, respectively. The maximum amplitude of pulses one through four, normalized by the amplitude of pulse one are 1.0, 0.83, 0.56, and 0.14, respectively.

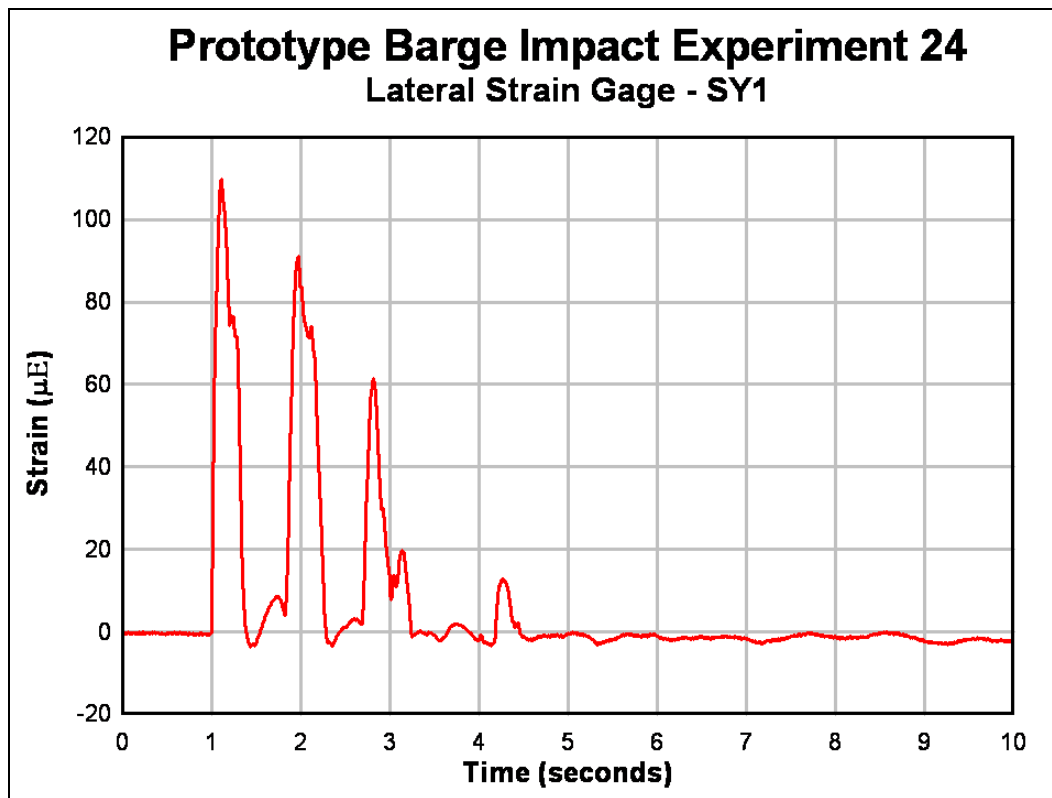

Figure B.6. Lateral Strain Gage SY1 (Channel 12) time history in the transverse direction on the deck plate for Experiment 8.

Figure B.7 shows the Fourier transformation of the strain gage parallel to the bow of the barge recorded during experiment number 24. The natural frequencies for the first seven modes are 1.08 Hz, 1.9 Hz, 2.23 Hz, 2.89 Hz, 3.48 Hz, 4.71 Hz, 5.29 Hz, and 5.79 Hz, respectively. Again, the near zero frequency is a long period wave form, is artificial; introduced by the

recording instrumentation. It is not inherent to the structural system and is ignored.

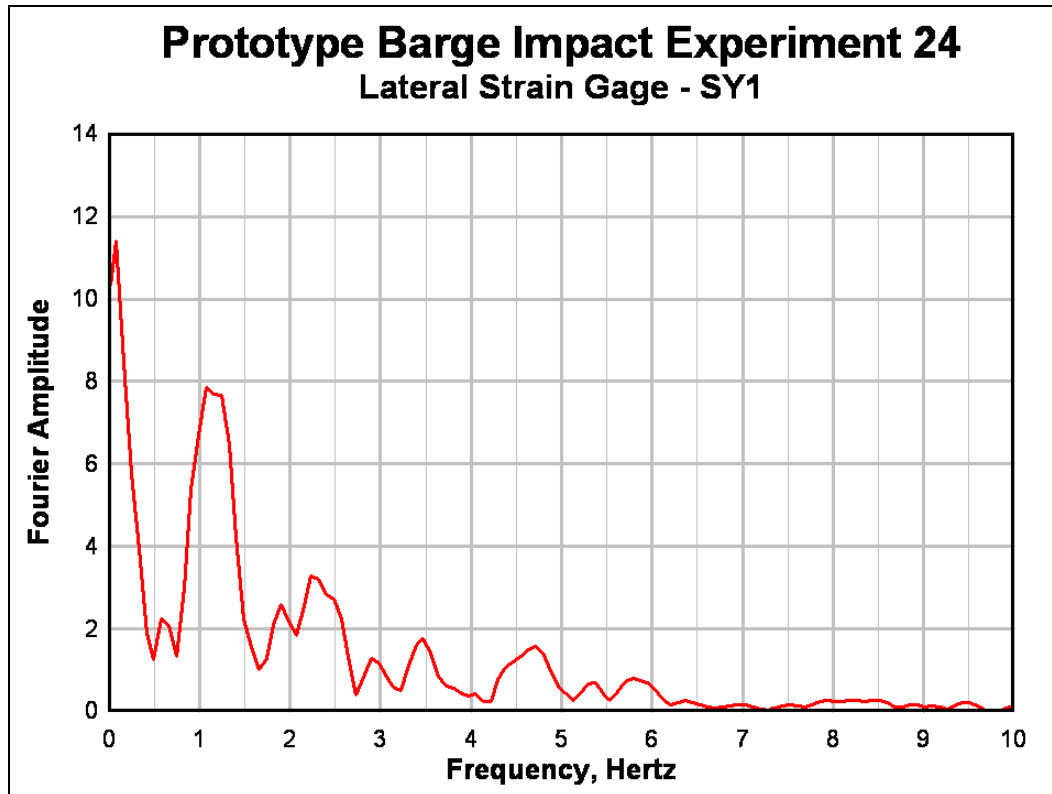

Figure B.7. Fourier transformation of the Lateral Strain Gage SY1 (Channel 12) time history in the transverse direction on the deck plate for Experiment 24.

Figure B.8 shows the strain time history recorded by the strain gage oriented parallel with the bow and mounted close to the impact corner on the deck plate in Experiments 8, 9, 11, 12, 13, and 14. Observe there are five distinct pulses in Experiment 11 while there are four distinct pulses in all the other strain pulse time histories. Observe that the largest amplitude of compression strain, and thus impact force, occurs during the first pulse in all 5 experiments shown in this figure. Also note how for these independent impacts with the stiff-to-rigid wall at Old Lock and Dam 2, the compression strain pulses, especially the early pulses, tend to overlay one another.

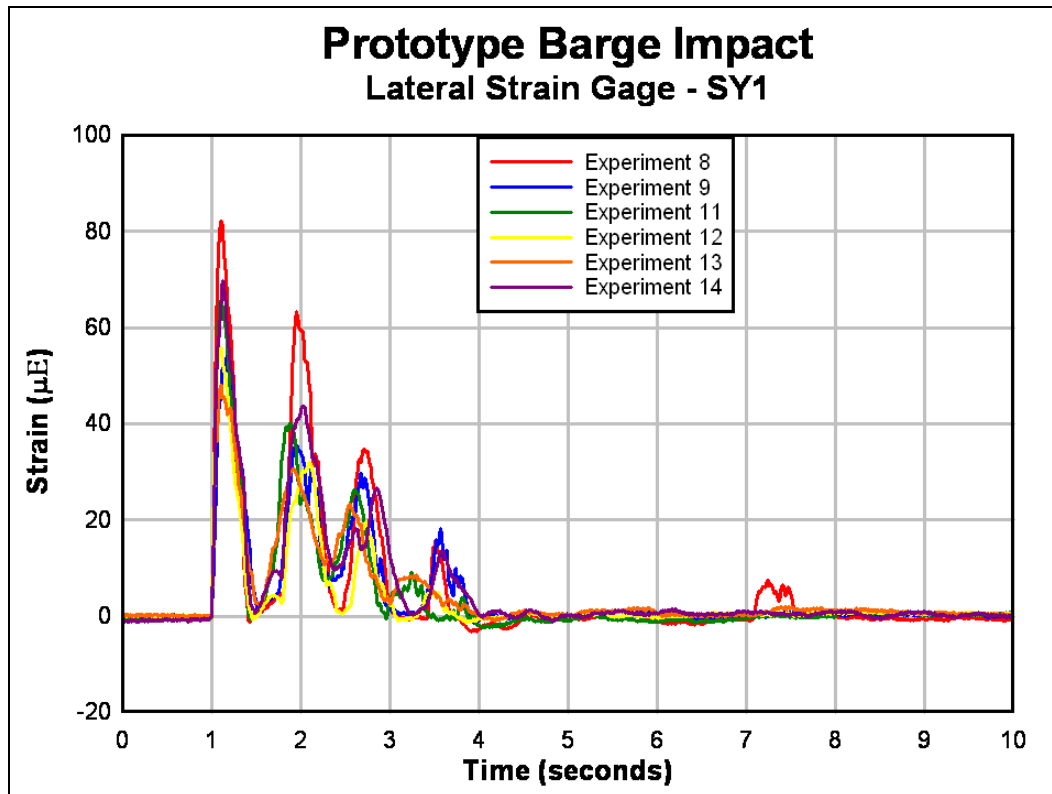

Figure B.8 Lateral Strain Gage SY1 (Channel 12) time histories in the transverse direction on the deck plate for Experiments 8, 9, 11, 12, 13, and 14.

Figure B.9 shows the strain time history recorded by the strain gage oriented parallel with the bow and mounted close to the impact corner on the deck plate in Experiments 15, 16, 17, 18, 19, and 20. The compression strain pulse time history for Experiment 8 is included in this figure for reference. Observe there are only three distinct pulses in Experiments 19 and 20 while there are four distinct pulses in all the other strain pulse time histories. Observe that the largest amplitude of compression strain, and thus impact force, occurs during the first pulse in all 7 experiments shown in this figure (including Experiment 8). Also note how for these independent impacts with the stiff-to-rigid wall at Old Lock and Dam 2, the compression strain pulses, especially the early pulses, tend to overlay one another.

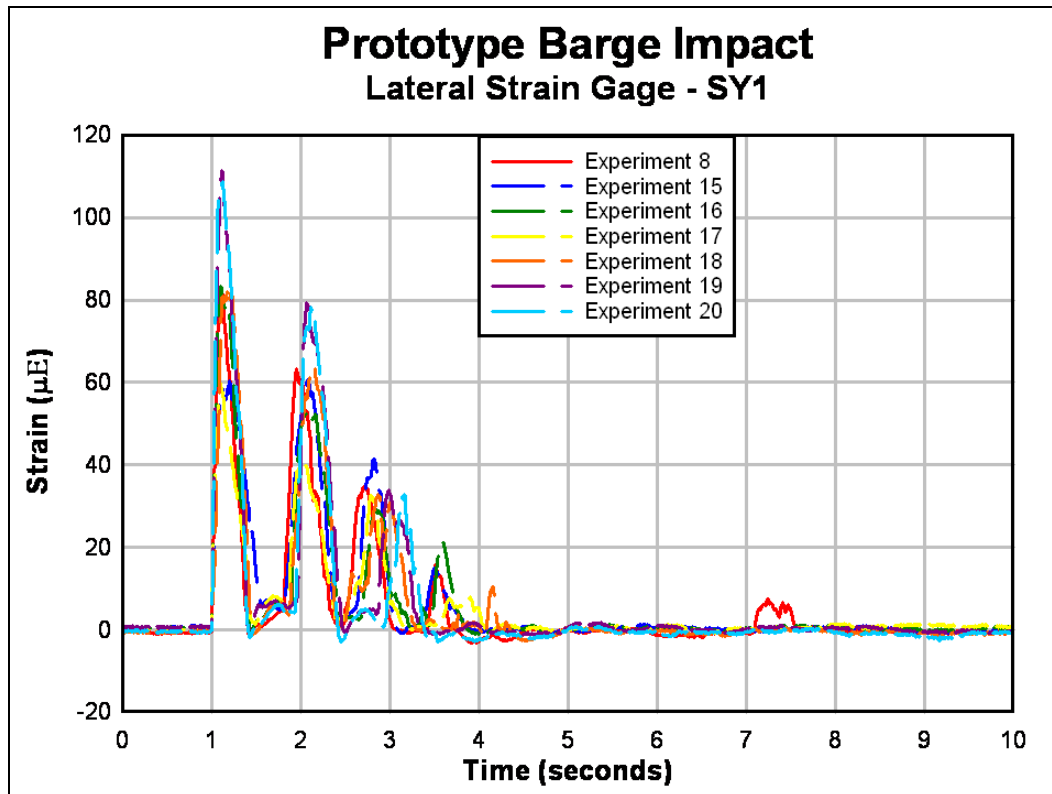

Figure B.9. Lateral Strain Gage SY1 (Channel 12) time histories in the transverse direction on the deck plate for Experiments 8, 15, 16, 17, 18, 19, and 20.

Figure B.10 shows the strain time history recorded by the strain gage oriented parallel with the bow and mounted close to the impact corner on the deck plate in Experiments 21, 22, 23, 24, and 25. The compression strain pulse time history for Experiment 8 is included in this figure for reference. Observe there are five distinct pulses in Experiment 25 while there are four distinct pulses in all the other strain pulse time histories. Observe that the largest amplitude of compression strain, and thus impact force, occurs during the first pulse in all 6 experiments shown in this figure (including Experiment 8). Also note how for these independent impacts with the stiff-to-rigid wall at Old Lock and Dam 2, the compression strain pulses, especially the early pulses, tend to overlay one another.

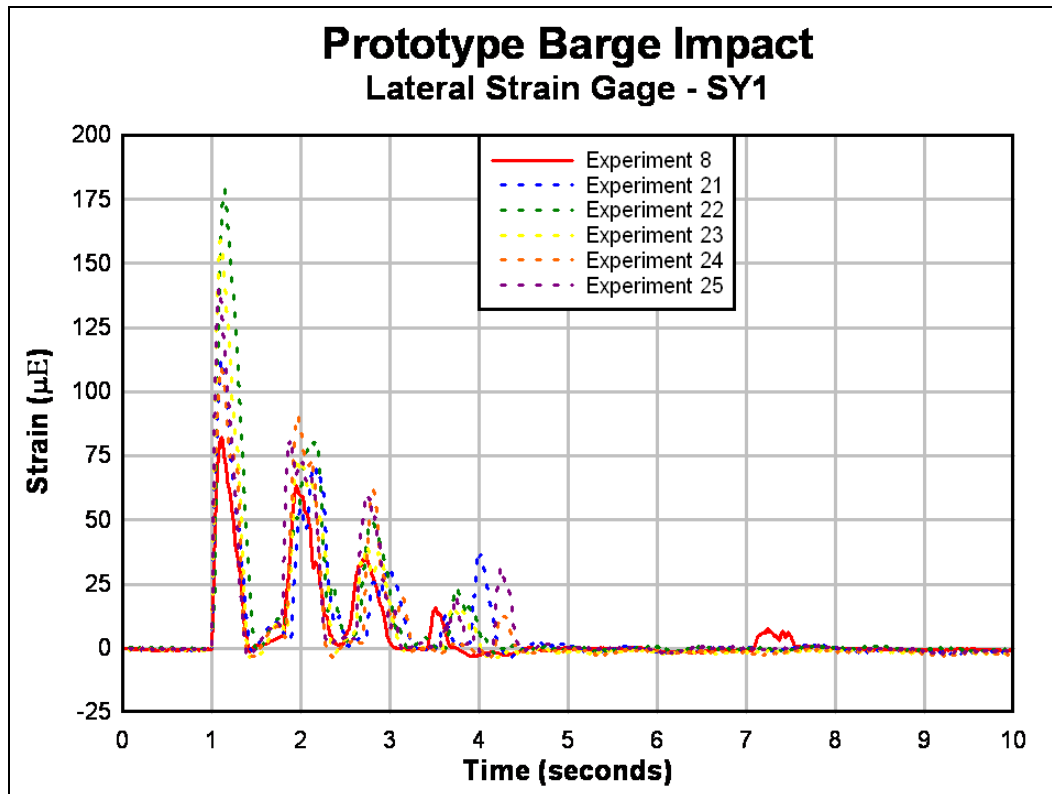

Figure B.10. Lateral Strain Gage SY1 (Channel 12) time histories in the transverse direction on the deck plate for Experiments 8, 21, 22, 23, 24, and 25.

As part of the processing of the strain gage time-history data, the peak amplitude for each pulse in each of the time histories was measured and then normalized by the maximum amplitude occurring in the first pulse. Table B.2 summarizes the results of this processing. Since all maximum strain values were normalized by the maximum (compression) strain occurring in the first pulse, the normalized amplitude for pulse 1 is always equal to one. The maximum amplitude of the second pulse, normalized by the maximum amplitude of the first pulse, is observed to be a value less than one for all experiments with the exception of Experiment 15. It is observed that the maximum amplitude for pulse 3, normalized by the maximum amplitude for pulse 1, is less than the normalized amplitude of pulse 2 in all Experiments. The normalized amplitude of pulse 4 is less than the normalized amplitude of pulse 3 in all Experiments.

Table B.2. Summary Data for Lateral Strain Gage SY1 (Channel 12) Maximum Compression Strain in Each of 5 Pulses Normalized by the Peak Strain in the First Pulse for the Transverse Deck Plate Strain.

Experiment No.	$\Delta t_{\text{duration}}$ (sec)	Pulse No.	1	2	3	4	5
		No. Pulses	P_1/F_{max} or $F_{\text{max}}/F_{\text{max}}$	P_2/F_{max}	P_3/F_{max}	P_4/F_{max}	P_5/F_{max}
8	2.83	4	1	0.8	0.43	0.21	
9	2.93	4	1	0.66	0.56	0.34	
10	3.76	5	1	0.65	0.43	0.4	0.35
11	2.93	5	1	0.61	0.41	0.14	0.06
12	2.83	4	1	0.58	0.36	0.11	
13	3.12	4	1	0.65	0.51	0.23	
14	3.02	4	1	0.64	0.41	0.24	
15	2.93	4	1	1	0.69	0.25	
16	2.93	4	1	0.64	0.37	0.28	
17	3.02	4	1	0.68	0.54	0.14	
18	3.31	4	1	0.78	0.26	0.14	
19	2.44	3	1	0.72	0.32		
20	2.44	3	1	0.71	0.3		
21	3.32	4	1	0.63	0.27	0.33	
22	3.12	4	1	0.45	0.27	0.13	
23	3.02	4	1	0.47	0.26	0.1	
24	3.51	4	1	0.83	0.56	0.14	
25	3.51	5	1	0.59	0.43	0.14	0.22

Table B.3 summarizes the statistics for the Table B.2 normalized maximum amplitude (compression) strain data. It is expressed in terms of the mean value, standard deviation, coefficient of variation (i.e., COV), and the range in values for each of the normalized maximum pulse amplitudes.

Table B.3. Summary Statistics for Lateral Strain Gage SY1 (Channel 12) Maximum Compression Strain in Each of 5 Pulses Normalized by the Peak Strain in the First Pulse for the Transverse Deck Plate Strain.

Pulse No. i	No. of Impact Experiments Containing Pulse No. i	Mean (P_i/F_{max})	Standard Deviation (P_i/F_{max})	COV (P_i/F_{max})	Minimum (P_i/F_{max})	Maximum (P_i/F_{max})
1	18	1	0	0	1	1
2	18	0.67	0.13	0.19	0.45	1
3	18	0.41	0.12	0.30	0.26	0.69
4	16	0.21	0.09	0.45	0.1	0.4
5	3	0.21	0.15	0.69	0.06	0.35

Table B.4 summarizes the time to peak for the first pulse (i.e., the maximum amplitude pulse) and the duration of each of the pulses (up to 5 pulses) for each of the (compression) strain gage time histories.

Table B.4. Summary of duration of impact, time to peak transverse deck plate strain and the duration of each strain pulse (for up to five pulses).

Experiment No.	$\Delta t_{\text{duration}}$ (sec)	Pulse No.	1	2	3	4	5
		Δt_{peak} (sec)	Duration Δt_1 (sec)	Duration Δt_2 (sec)	Duration Δt_3 (sec)	Duration Δt_4 (sec)	Duration Δt_5 (sec)
8	2.83	0.111	0.415	0.59	0.58	0.26	
9	2.93	0.194	0.536	0.79	0.63	0.54	
11	2.93	0.104	0.425	0.703	0.6	0.452	0.43
12	2.83	0.1	0.469	0.618	0.536	0.556	
13	3.12	0.117	0.504	0.712	0.586	0.58	
14	3.02	0.134	0.465	0.859	0.809	0.747	
15	2.93	0.209	0.559	0.622	0.636	0.56	
16	2.93	0.1106	0.4426	0.5352	0.548	0.362	
17	3.02	0.104	0.456	0.535	0.701	0.532	
18	3.31	0.1863	0.4753	0.589	0.822	0.138	
19	2.44	0.123	0.413	0.529	0.465		
20	2.44	0.127	0.431	0.5162	0.471		
21	3.32	0.117	0.458	0.634	0.509	0.452	
22	3.12	0.152	0.507	0.682	0.42	0.48	
23	3.02	0.102	0.428	0.503	0.517	0.446	
24	3.51	0.117	0.428	0.481	0.554	0.262	
25	3.51	0.092	0.408	0.517	0.523	0.296	0.289

Table B.5.a summarizes the statistics of the time to peak for the first pulse (i.e., the maximum amplitude pulse) and the duration of each of the pulses (up to 5 pulses) for each of the (compression) strain gage time histories. It is expressed in terms of the mean value, standard deviation, coefficient of variation (i.e. COV), and the range in values for each of the normalized maximum pulse amplitudes. Table B.5.b summarizes the statistics of the duration of contact with the wall, $\Delta t_{\text{duration}}$. It is expressed in terms of the mean value, standard deviation, coefficient of variation (i.e., COV), and the range in values.

Table B.5.a. Summary Statistics for Lateral Strain Gage SY1 (Channel 12) time to Maximum Compression Strain and duration of each pulse of Transverse Deck Plate Strain.

Pulse No. i	Time to Peak (Δt_{peak}) or Duration of Transverse Deck Strain (Δt_i) for Pulse No. i (sec)	Mean (sec)	Standard Deviation (sec)	COV	Minimum (sec)	Maximum (sec)
1	Δt_{peak}	0.13	0.04	0.27	0.09	0.21
1	Δt_1	0.46	0.04	0.10	0.41	0.56
2	Δt_2	0.61	0.11	0.17	0.48	0.86
3	Δt_3	0.58	0.11	0.19	0.42	0.82
4	Δt_4	0.44	0.16	0.35	0.14	0.75
5	Δt_5	0.36	0.1	0.28	0.29	0.43

Table B.5.b. Summary Statistics for Lateral Strain Gage SY1 (Channel 12) duration of total contact with the wall during primary impact pulses.

Duration of Contact During Primary Contact Pulses	Mean (sec)	Standard Deviation (sec)	COV	Minimum (sec)	Maximum (sec)
$\Delta t_{\text{duration}}$	3.05	0.34	0.11	2.44	3.76

Table B.6.a provides a summary of duration of impact and time to peak transverse deck plate (compression) strain for each experiment. It also includes a summary of the natural frequencies (in units of Hz) computed by Fourier Transformation (up to the first 7). The inverse of the Table B.6.a frequencies is given in Table B.6.b, expressed as natural periods in units of seconds. Recall that the natural period is equal to the inverse of natural frequency.

Table B.6.a. Summary of duration of impact, time to peak transverse deck plate strain and the natural frequencies by Fourier Transformation.

Experiment No.	$\Delta t_{\text{duration}}$ (sec)	Δt_{peak} (sec)	f_1 (hz)	f_2 (hz)	f_3 (hz)	f_4 (hz)	f_5 (hz)	f_6 (hz)	f_7 (hz)	f_8 (hz)
8	2.83	0.111	1.24	1.98	2.48	3.31	3.804	4.458		
9	2.93	0.194	0.83	1.24	1.99	2.56	3.72	4.962		
11	2.93	0.104	1.41	1.99	2.65	4.05				
12	2.83	0.1	1.24	1.90	2.56	3.06	3.72	4.8		
13	3.12	0.117	0.83	1.41	2.15					
14	3.02	0.134	1.16	2.32	2.89	3.56	4.05			
15	2.93	0.209	1.24	1.82	2.40	2.90	3.31			
16	2.93	0.1106	1.16	1.74	1.99	2.40	2.90	3.56	4.47	
17	3.02	0.104	1.16	1.82	2.32	3.47	4.63			
18	3.31	0.1863	1.08	2.07	3.56	4.14	4.63			
19	2.44	0.123	0.99	2.07	3.23	4.3	5.38			
20	2.44	0.127	0.99	1.99	2.98	4.14				
21	3.32	0.117	1.08	1.74	2.07	2.40	2.73	3.47	4.47	
22	3.12	0.152	1.16	1.90	2.32	3.06	3.80			
23	3.02	0.102	1.16	1.90	2.23	3.47	4.38	5.05		
24	3.51	0.117	1.08	1.90	2.23	2.89	3.48	4.71	5.29	5.79
25	3.51	0.092	1.24	1.90	2.23	3.14	3.80	4.96		

Table B.6.b. Summary of duration of impact, time to peak transverse deck plate strain and the inverse of natural frequencies (from Fourier Transformation).

Experiment No.	$\Delta t_{\text{duration}}$ (sec)	Δt_{peak} (sec)	T_1 (sec)	T_2 (sec)	T_3 (sec)	T_4 (sec)	T_5 (sec)	T_6 (sec)	T_7 (sec)	T_8 (sec)
8	2.83	0.111	0.81	0.51	0.40	0.30	0.26	0.22		
9	2.93	0.194	1.21	0.81	0.50	0.39	0.27	0.20		
11	2.93	0.104	0.71	0.50	0.38	0.25				
12	2.83	0.1	0.81	0.53	0.39	0.33	0.27	0.21		
13	3.12	0.117	1.21	0.71	0.47					
14	3.02	0.134	0.86	0.43	0.35	0.28	0.25			
15	2.93	0.209	0.81	0.55	0.42	0.35	0.30			
16	2.93	0.1106	0.86	0.58	0.50	0.42	0.35	0.28	0.22	
17	3.02	0.104	0.86	0.55	0.43	0.29	0.22			
18	3.31	0.1863	0.93	0.48	0.28	0.24	0.22			
19	2.44	0.123	1.01	0.48	0.31	0.23	0.19			
20	2.44	0.127	1.01	0.50	0.34	0.24				
21	3.32	0.117	0.93	0.58	0.48	0.42	0.37	0.29	0.22	
22	3.12	0.152	0.86	0.53	0.43	0.33	0.26			

Experiment No.	$\Delta t_{\text{duration}}$ (sec)	Δt_{peak} (sec)	T ₁ (sec)	T ₂ (sec)	T ₃ (sec)	T ₄ (sec)	T ₅ (sec)	T ₆ (sec)	T ₇ (sec)	T ₈ (sec)
23	3.02	0.102	0.86	0.53	0.45	0.29	0.23	0.20		
24	3.51	0.117	0.93	0.53	0.45	0.35	0.29	0.21	0.19	0.17
25	3.51	0.092	0.81	0.53	0.45	0.32	0.26	0.20		

Table B.7.a is a summary of the Table B.4 individual pulse durations multiplied by 2. These Table B.7.a values may then be compared to the Table B.6.b values. The principal author of this report concludes that these two sets of numbers are comparable for the first mode; indicating that the first (compression) pulse is likely first mode dominated.

Table B.7.a. Summary of duration of impact, time to peak transverse deck plate strain and two times the duration of each strain pulse (for up to five pulses).

Experiment No.	$\Delta t_{\text{duration}}$ (sec)	Pulse No.	1	2	3	4	5
		Δt_{peak} (sec)	$2*\Delta t_1$ (sec)	$2*\Delta t_2$ (sec)	$2*\Delta t_3$ (sec)	$2*\Delta t_4$ (sec)	$2*\Delta t_5$ (sec)
8	2.83	0.111	0.83	1.18	1.16	0.52	
9	2.93	0.194	1.072	1.58	1.26	1.08	
11	2.93	0.104	0.85	1.406	1.2	0.904	0.86
12	2.83	0.1	0.938	1.236	1.072	1.112	
13	3.12	0.117	1.008	1.424	1.172	1.16	
14	3.02	0.134	0.93	1.718	1.618	1.494	
15	2.93	0.209	1.118	1.244	1.272	1.12	
16	2.93	0.1106	0.8852	1.0704	1.096	0.724	
17	3.02	0.104	0.912	1.07	1.402	1.064	
18	3.31	0.1863	0.9506	1.178	1.644	0.276	
19	2.44	0.123	0.826	1.058	0.93		
20	2.44	0.127	0.862	1.0324	0.942		
21	3.32	0.117	0.916	1.268	1.018	0.904	
22	3.12	0.152	1.014	1.364	0.84	0.96	
23	3.02	0.102	0.856	1.006	1.034	0.892	
24	3.51	0.117	0.856	0.962	1.108	0.524	
25	3.51	0.092	0.816	1.034	1.046	0.592	0.578

The inverse of the Table B.7.a values, are given in Table B.7.b. They would be an approximation to the natural frequency if the pulse were single mode dominant. It is not clear to the principal author of this report if the Table B.7.b data is relevant or useful. If natural frequencies were of interest, please refer to Fourier Transformation results given in Table B.6.b.

Table B.7.b. Summary of duration of impact, time to peak transverse deck plate strain and the inverse of the product of two times the duration of each strain pulse (for up to five pulses).

Experiment No.	$\Delta t_{\text{duration}}$ (sec)	Pulse No.	1	2	3	4	5
		Δt_{peak} (sec)	apx. of f (hz)	apx. of f (hz)	apx. of f (hz)	apx. of f (hz)	apx. of f (hz)
8	2.83	0.111	1.20	0.85	0.86	1.92	
9	2.93	0.194	0.93	0.63	0.79	0.93	
11	2.93	0.104	1.18	0.71	0.83	1.11	1.16
12	2.83	0.1	1.07	0.81	0.93	0.90	
13	3.12	0.117	0.99	0.70	0.85	0.86	
14	3.02	0.134	1.08	0.58	0.62	0.67	
15	2.93	0.209	0.89	0.80	0.79	0.89	
16	2.93	0.1106	1.13	0.93	0.91	1.38	
17	3.02	0.104	1.10	0.93	0.71	0.94	
18	3.31	0.1863	1.05	0.85	0.61	3.62	
19	2.44	0.123	1.21	0.95	1.08		
20	2.44	0.127	1.16	0.97	1.06		
21	3.32	0.117	1.09	0.79	0.98	1.11	
22	3.12	0.152	0.99	0.73	1.19	1.04	
23	3.02	0.102	1.17	0.99	0.97	1.12	
24	3.51	0.117	1.17	1.04	0.90	1.91	
25	3.51	0.092	1.23	0.97	0.96	1.69	1.73

Appendix C: Listing and Description of Impact_Force ASCII Input Data File (file name:Impact_Force.IN)

This appendix lists and describes the contents of the ASCII input data file to the FORTRAN engineering computer program portion of Impact_Force. This data file, always designated as Impact_Force.IN, is created by the graphical user interface (GUI), the visual modeler portion of Impact_Force. The software uses the Impulse Linear Momentum Principle in conjunction with a response modification factor (RMF)¹ to compute the Figure C.1 force time history of individual pulses, $F_{\text{normal-wall}}(t)$, acting normal to a approach wall for use in the structural analysis of deformable/flexible approach walls at locks.

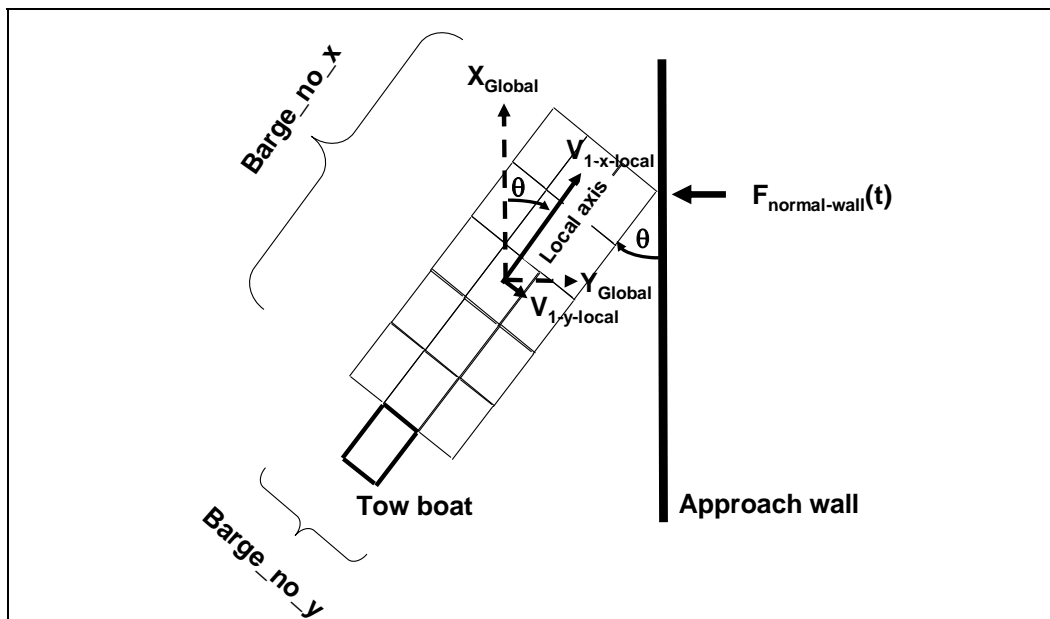

Figure C.1. Barge train with initial contact velocity components $V_{1-x\text{-local}}$ and $V_{1-y\text{-local}}$ along the local barge axis at time t_1 of initial contact with the approach wall and with the barge train oriented at a constant approach angle θ to the wall's X_{Global} axis.

¹ The response modification factor is a scale factor applied to the momentum of the barge train. Values for the RMF based on full-scale impact tests conducted by Barker, et al;. (2010) at Winfield are discussed in Appendix A and Chapter 2.

The ASCII input data to Impact_Force is provided in 13 groups of data. They are as follows:

Group #1 – Units for the problem.

Gconstant, Factor, RMF, Key_Analysis

The values for Gconstant and Factor identify the units of length, velocity, force (and weight), and mass being used according to Table C.1 below.

Table C.1. Specification of Units.

Value for Gconstant	Value for Factor	Units of Length	Velocity	Units of Force (and Weight)	Units of Mass
32.174	1000	feet	ft/sec	kips	kips-sec ² /ft
386.086	1000	inches	in/sec	kips	kips-sec ² /inch
32.174	1	feet	ft/sec	lbs	lbs-sec ² /ft
386.086	1	inches	in/sec	lbs	lbs-sec ² /inch
9.80665	1	meters	m/sec	kN	kN-sec ² /m
980.665	1	centimeters	cm/sec	kN	kN-sec ² /cm
9806.65	1	millimeters	mm/sec	kN	kN-sec ² /mm

The value for RMF is the response modification factor; a scale factor applied to the momentum of the barge train.

Key_Analysis is an integer key that represents the option of choosing what kind of pulse time history will be used for the analysis. The three options of pulse time histories are:

- = 1 a user-constructed unit pulse time history
- = 2 a user-provided unit pulse time history of Pittsburgh or Winfield Barge Impact Data
- = 3 a user-provided unit pulse time history created by Impact_Force.

***Note: A unit pulse time history has a maximum amplitude of 1.0.**

Group #2 – Barge Train Approach Velocity – In Local Barge Coordinates.

V1_x_local, V1_y_local

V1_x_local is the x-component of the barge approach velocity expressed along the local axis of the barge train (as labeled in Figure C.1) just prior to impact with the approach wall.

V1_y_local is the y-component of the barge approach velocity expressed along the local axis of the barge train (as labeled in Figure C.1) just prior to impact with the approach wall.

Group #3 – Barge Train Approach Angle

Theta

Theta is the approach angle for the barge train as measured from the face of the approach wall (i.e., from the global x-axis).

Group #4 – Barge Train Weights

Weight_per_barge, Weight_tow

Weight_per_barge is the (average) weight of each barge comprising the barge train (including both cargo capacity and tare weight of a typical barge).

Weight_tow is the weight of the tow boat.

Group #5 – Barge Train Hydrodynamic Added Mass Factors

Hydro_Added_Mass_x_local, Hydro_Added_Mass_y_local

Hydro_Added_Mass_x_local is the hydrodynamic added mass factor in the local barge x-axis direction of the barge train (e.g., 1.05).

Hydro_Added_Mass_y_local is the hydrodynamic added mass factor in the local barge y-axis direction of the barge train (e.g., 1.4).

Group #6 – Size of Barge Train

Barge_no_x, Barge_no_y

Barge_no_x is the number of rows of barges as counted along the local x-axis of the barge train (as labeled in Figure C.1).

Barge_no_y is the number of columns of barges as counted along the local y-axis of the barge train (as labeled in Figure C.1).

***Note: If Key_Analysis = 1 then complete Groups #7 – #10; otherwise, proceed to the Note prior to Group #11.**

Group #7 – General Impact Force Time History of Pulses Information.

T1, DT_duration, DT_time_step, No_pulses

T1 is the start time of the first pulse in seconds (as labeled in Figure C.2); can be zero but doesn't have to be.

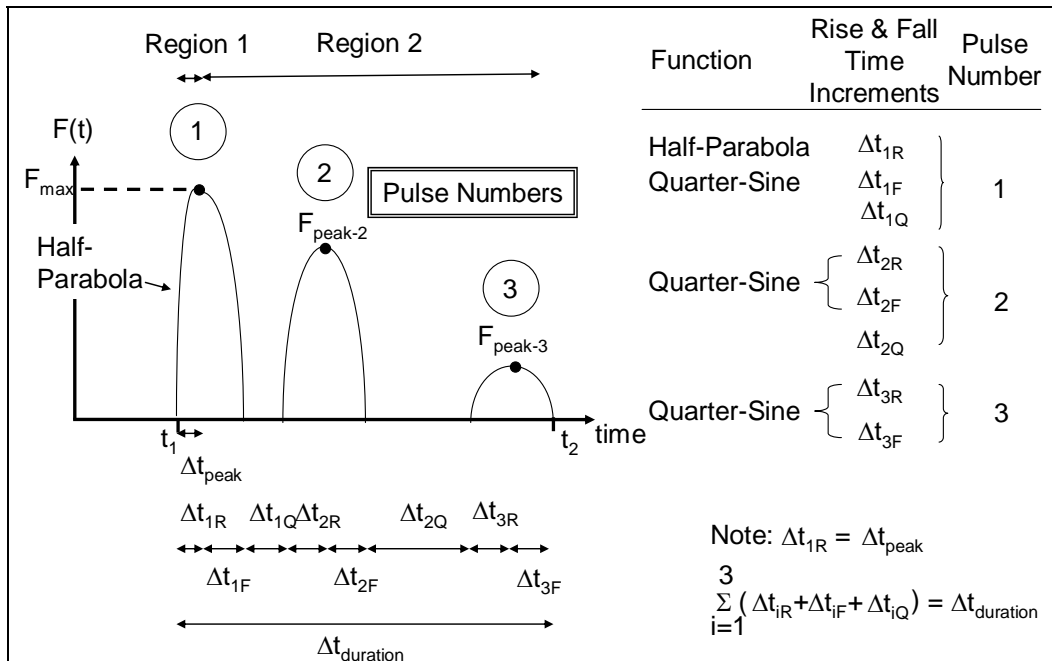

Figure C.2. Example of a force time history with 3 pulses created using Impact_Force.

DT_duration is the total duration of the impact force time history of pulses in seconds; from initial time of contact with the wall at time t1 to the end of contact at time t2 in Figure C.2.

DT_time_step is the time step of the impact force time history to be created (e.g., 0.02 or 0.01 or 0.005 second, etc.).

No_pulses is the total number of individual pulses (integer) comprising the impact force time history (e.g., No_pulses = 3 in Figure C.2).

Group #8 – Fractional Maximum Amplitude of Each Pulse of the Force Time History.

No_of_Pulse_FR(i), FR(i) for i = 1, No_pulses

No_of_Pulse_FR (i) is an integer count of the pulse number (i.e., 1, 2, etc.). Refer to Figure C.3 for an example of a force time history with 3 pulses in which the forces are normalized by the peak force in pulse number 1.

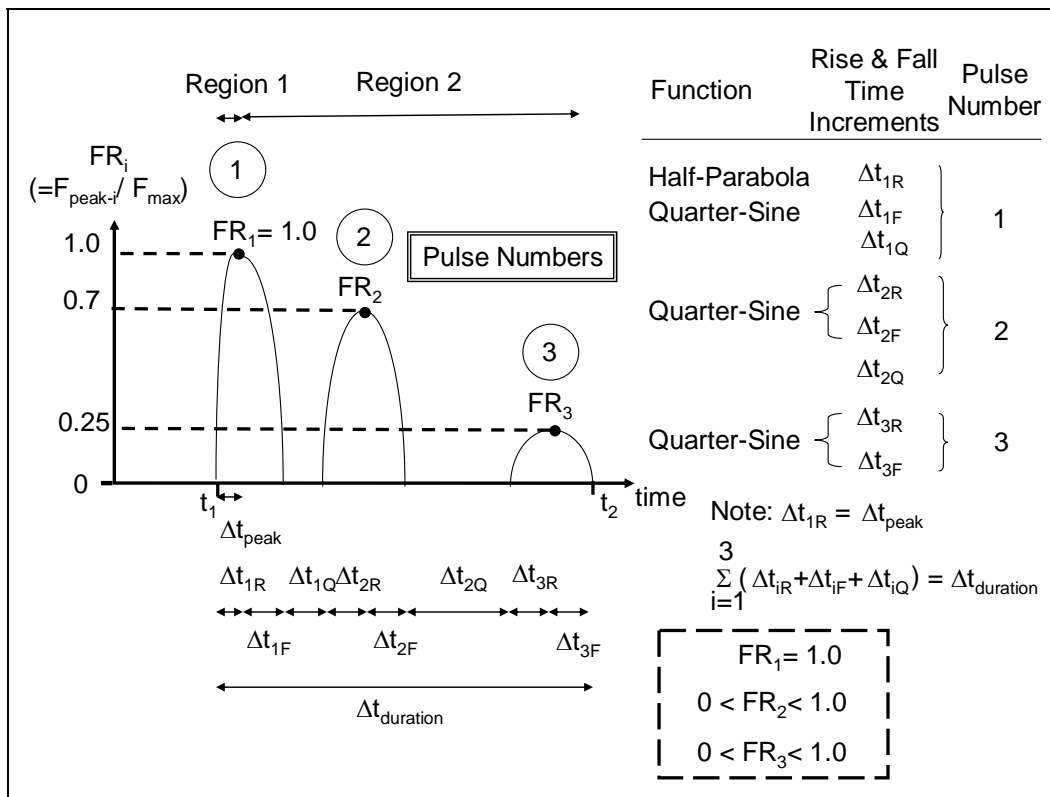

Figure C.3. Example of user provided fractional maximum amplitudes FR_i for a force time history with 3 pulses.

FR(i) is the decimal fraction of the maximum amplitude for pulse i (designated as F_{Peak-i} with i = 1 to the 3 in Figure C.2) divided by the maximum amplitude of pulse 1 (designated F_{MAX} in Figure C.2); typically FR(i) is a value less than or equal to 1.0. Note the vertical axis for the

Figure C.3 example is the decimal fraction $FR(i)$ for each pulse i . There are three user specified values for $FR(i)$ for each of the $i = 1, 2$ and 3 pulses shown in the Figure C.3 example. For the first pulse $FR(1)$ is equal to 1.0.

Internal to Impact_Force: The Figure C.2 peak force F_{peak_i} for each $No_of_Pulse(i)$ (i.e., 1, 2 and 3) is equal to the Figure C.3 $FR(i)$ times the Figure C.2 F_{max} , where F_{max} is the maximum force of pulse number 1. F_{max} is first computed by the Impact_Force program then the values for each Figure C.2 force F_{peak_i} of each $No_of_Pulse_FR(i)$ is computed.

Group #9 – Specific Times for Each Pulse of the Force Time History.

$No_of_Pulse_DT(i)$, $DT_rise(i)$, $DT_fall(i)$, $DT_quiet(i)$ for $i = 1$, No_pulses

$No_of_Pulse_DT(i)$ is an integer count of the pulse number (i.e., 1, 2, etc.).

$DT_rise(i)$ is the rise time in seconds of pulse number $No_of_Pulse(i)$; designated Δt_{1R} in Figures C.2 & C.3.

$DT_fall(i)$ is the fall time in seconds of pulse number $No_of_Pulse(i)$; designated Δt_{1F} in Figures C.2 & C.3.

$DT_quiet(i)$ is the time in seconds during which the force is equal to zero for pulse number $No_of_Pulse(i)$; designated Δt_{1Q} in Figures C.2 & C.3. For the last pulse the duration of quiet time, $DT_quiet(No_pulses)$, is set equal to zero.

Note: $\sum_{i=1}^{No_pulses} [DT_rise(i) + DT_fall(i) + DT_quiet(i)]$ must equal

$DT_duration$. The start and end times for the rise, fall and quiet portion, respectively, of each pulse is equal to the sum of the user specified rise, fall and quiet times of the proceeding pulses. Additionally, the user specified time step will dictate if the discrete points created to represent the force time history exactly correspond to the exact start time for the start of each rise portion of a pulse, the exact time of peak force of a pulse, and the exact end time of zero force at the end of the fall time of each pulse.

Group #10 – Specification of Geometric Shapes for the Rise and Fall portions of Each Pulse i of the Force Time History. (Two groups of data.)

**No_of_Pulse_rise(i), I_type_rise(i), FR_rise_pt.1(i), FR_rise_pt.2(i) for $i = 1$,
No_pulses**

**No_of_Pulse_fall(i), I_type_fall(i), FR_fall_pt.1(i), FR_fall_pt.2(i) for $i = 1$,
No_pulses**

No_of_Pulse_rise (i) is an integer count of the pulse number (i.e., 1, 2, etc.) in the force time history. Refer to Figures C.2 & C.3 for an example of a force time history with 3 pulses.

I_type_rise(i) = 1 for quarter-ellipse
 = 2 for half-parabola
 = 3 for a quarter-sine
 = 4 for a trapezoid (special cases are a triangular function and a step function).

FR_rise_pt.1(i) is the decimal fraction (less than or equal to 1.0 and greater than or equal to 0) of the peak force at point 1 of rise pulse i when a trapezoid is specified. (Refer to Figure C.4.)

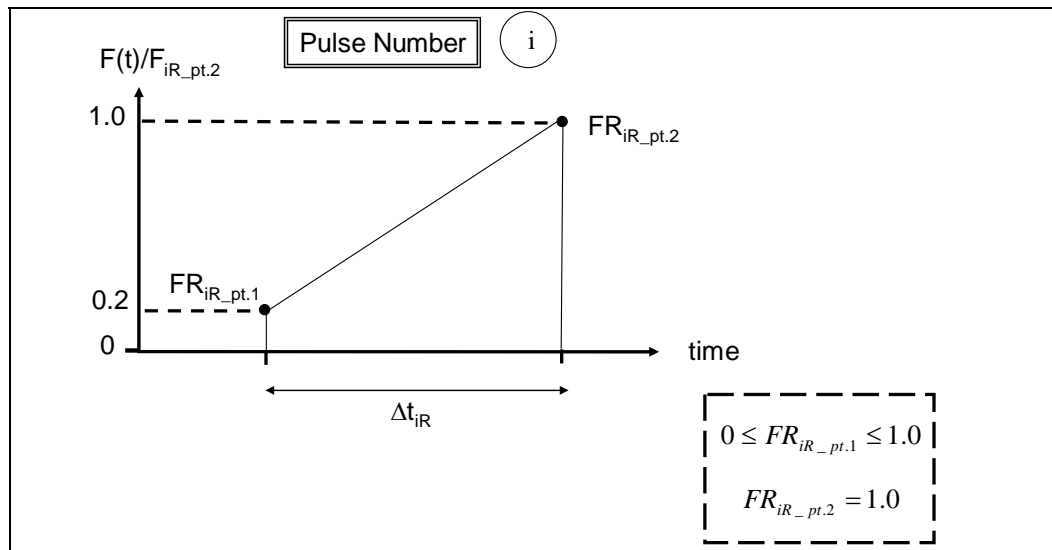

Figure C.4. Example of user provided fractional maximum amplitudes FR for the trapezoidal rise portion of pulse i .

FR_rise_pt.2(i) is the decimal fraction, typically set equal to 1.0 (and greater than or equal to 0) of the peak force at point 2 of rise pulse i when a trapezoid is specified. (Refer to Figure C.4.)

In the case of I_type_rise(i) equal to 1, 2 or 3, FR_rise_pt.1(i) and FR_rise_pt.2(i) are not used and set equal to zero.

In the case of I_type_rise(i) equal to 4, FR_rise_pt.1(i) and FR_rise_pt.2(i) are decimal fractions, designated as FR_{iR_pt.1} and FR_{iR_pt.2}, respectively, of the peak force for pulse i at the start and end of the rise portion of the Figure C.4 pulse i. FR_rise_pt.1(i) is set equal to 1.0 for a step function and is set equal to zero for a triangular function during the rise time. The example trapezoid shown in Figure C.4 has a FR_rise_pt.2(i) set equal to 1.0 and FR_rise_pt.1(i) set equal to 0.2.

Internal to Impact_Force: The peak force $F_{\text{peak-}i}$ for each trapezoid pulse i is equal to the Group # 8 FR(i) for pulse i times the maximum force of pulse number 1, F_{max} . The forces at points 1 and 2 of the trapezoid are equal to $F_{\text{peak-}i}$ times FR_rise_pt.1(i) and $F_{\text{peak-}i}$ times FR_rise_pt.2(i), respectively. F_{max} (for pulse 1) is first computed by the Impact_Force program, then the values for each force $F_{\text{peak-}i}$ of each No_of_Pulse_rise(i) are computed.

No_of_Pulse_fall (i) is an integer count of the pulse number (i.e., 1, 2, etc.) in the force time history. Refer to Figures C.2 & C.3 for an example of a force time history with 3 pulses.

I_type_fall(i)	= 1 for quarter-ellipse
	= 2 for half-parabola
	= 3 for a quarter-sine
	= 4 for a trapezoid (special cases are a triangular function and a step function).

FR_fall_pt.1(i) is the decimal fraction, typically set equal to 1.0 (and greater than or equal to 0) of the peak force at point 1 of fall pulse i when a trapezoid is specified. (Refer to Figure C.5.)

FR_fall_pt.2(i) is the decimal fraction (less than or equal to 1.0 and greater than or equal to 0) of the peak force at point 2 of fall pulse i when a trapezoid is specified. (Refer to Figure C.5.)

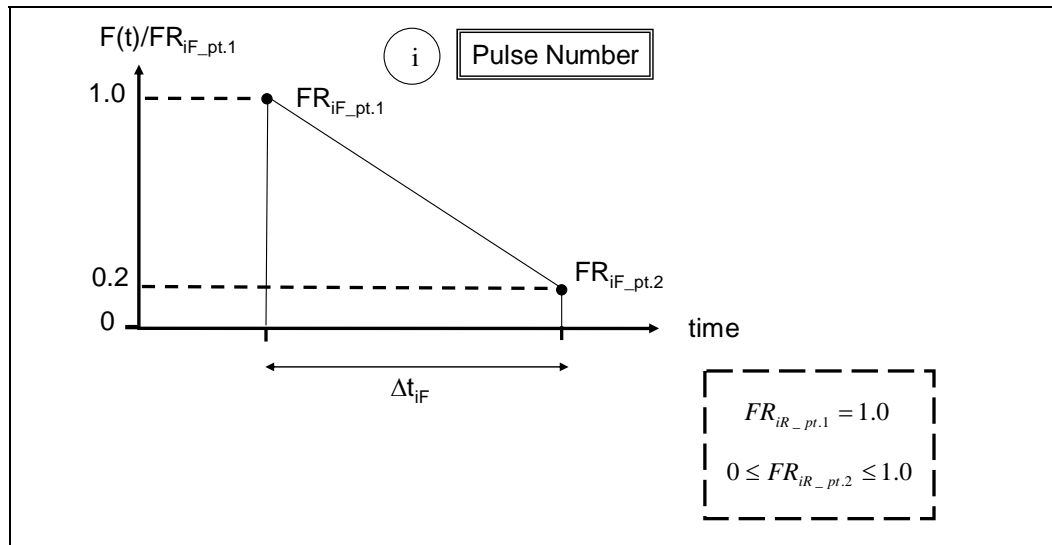

Figure C.5. Example of user provided fractional maximum amplitudes FR for the trapezoidal fall portion of pulse i .

In the case of $I_type_rise(i)$ equal to 1, 2 or 3, $FR_fall_pt.1(i)$ and $FR_fall_pt.2(i)$ are not used and are set equal to zero.

In the case of $I_type_fall(i)$ equal to 4, $FR_fall_pt.1(i)$ and $FR_fall_pt.2(i)$ are decimal fractions designated as $FR_{iF_pt.1}$ and $FR_{iF_pt.2}$, respectively, of the peak force for pulse i at the start and end of the fall portion of the Figure C.5 pulse i . $FR_fall_pt.2(i)$ is set equal to 1.0 for a step function and is set equal to zero for a triangular function during the fall time. The example trapezoid shown in Figure C.5 has a $FR_fall_pt.1(i)$ set equal to 1.0 and a $FR_fall_pt.2(i)$ set equal to 0.2.

Internal to Impact_Force: The peak force F_{peak-i} for each trapezoid pulse i is equal to the Group # 8 $FR(i)$ for pulse i times the maximum force of pulse number 1, F_{max} . The forces at points 1 and 2 of the trapezoid are equal to F_{peak-i} times $FR_rise_pt.1(i)$ and F_{peak-i} times $FR_rise_pt.2(i)$, respectively. F_{max} (for pulse 1) is first computed by the Impact_Force program then the values for each force F_{peak-i} of each $No_of_Pulse_fall(i)$ is computed.

***Note: If Key_Analysis = 1, then skip Groups #11 and #12.
If Key_Analysis = 2, complete Group #11 and skip Group #12.
If Key_Analysis = 3, then skip Group #11 and complete
Group #12.**

Group #11 – Analysis using Pittsburgh or Winfield Barge Impact Data

Analysis_File

Analysis_File is the full file path name to either a Pittsburgh Barge Impact unit pulse time history or a Winfield Barge Impact unit pulse time history. These unit pulse time histories will be provided to the user. Each of the unit pulse time histories will be stored in its respective directory, Pittsburgh_Barge_Impact or Winfield_Barge Impact. The user will select one of these files for use as the unit pulse time history used in the analysis.

An example of specifying the value for Analysis_File would be
C:\Temp\filename.dat

Group #12 – Analysis using Impact Force Time History Contents

This feature is for unit pulse time histories created by Impact_Force.

Instead of specifying the full path name of a time history as in Group #11, the contents of the unit pulse time history file will be specified in Group #12. The contents of the time history is broken into two parts, the header information and the time history. The header information is comprised of four lines of information: a title, a subtitle, any subsequent subtitles, and the number of time history elements along with the time step of the time history. The unit pulse time history will be represented by two columns of data, time and force.

Group #13 – Superposition of Unit Force Time History w/ Sine function(s)

No_freqs

FRAC(i) for i=1, No_freqs

Key_Amp

FREQ(i) for i=1, No_freqs

Key_Unit

No_freqs is the total number of individual frequencies (an integer) used for the sine function(s) that are to be superimposed on the unit force time history. Each of the sine functions to be superimposed on the Figure C.3 unit pulse time history Unit_Force(t) is of the form

$$\text{Add_to_Unit_Force}(t) = [\text{FRAC}(i) * \text{Maximum Amplitude}] * \sin(\omega * t) \quad (\text{C.1})$$

with ω being the user specified circular frequency (in units of radians per second) and the value for Maximum Amplitude is either equal to FR(1) for all pulses or equal to FR(j) for j=1 to No_pulses. The new Unit force becomes

$$\text{New_Unit_Force}(t) = \text{Unit_Force}(t) + \text{Add_to_Unit_Force}(t) \quad (\text{C.2})$$

FRAC(i) is the decimal fraction (less than or equal to 1.0 and greater than or equal to 0) of the peak force amplitude of the sine function “i” (for each i = 1 to No_freqs sine functions) expressed as a decimal fraction. The amplitude of each sine function “i” becomes equal to the product of the Maximum Amplitude value times the value specified for FRAC(i) for each sine function i.

Key_Amp is an integer key that allows the user to choose the maximum amplitude value to be used in the Maximum Amplitude term for the sine function(s). The choices are either the maximum amplitude for each individual pulse or the maximum amplitude of the first pulse applied to all pulses;

= 1 Maximum amplitude FR(i) for each Pulse (i = 1 to No_pulses)

= 2 Maximum amplitude is set to FR(1) for all pulses

FREQ(i) are the frequency magnitudes of each of the i = 1 through No_freqs sine functions. They may be specified in units of seconds for

FREQ(i) in Period, in units of HZ for FREQ(i) in Frequency, or in units of radians per second for FREQ(i) in circular frequency.

Key_Unit is an integer key that represents the units of the harmonic characteristics of the sine function. The three options of specifying the units are;

- = 1 for Period (seconds)
- = 2 for Frequency (Hz)
- = 3 for Circular Frequency (radians per second)

REPORT DOCUMENTATION PAGE

Form Approved
OMB No. 0704-0188

Public reporting burden for this collection of information is estimated to average 1 hour per response, including the time for reviewing instructions, searching existing data sources, gathering and maintaining the data needed, and completing and reviewing this collection of information. Send comments regarding this burden estimate or any other aspect of this collection of information, including suggestions for reducing this burden to Department of Defense, Washington Headquarters Services, Directorate for Information Operations and Reports (0704-0188), 1215 Jefferson Davis Highway, Suite 1204, Arlington, VA 22202-4302. Respondents should be aware that notwithstanding any other provision of law, no person shall be subject to any penalty for failing to comply with a collection of information if it does not display a currently valid OMB control number. **PLEASE DO NOT RETURN YOUR FORM TO THE ABOVE ADDRESS.**

1. REPORT DATE (DD-MM-YYYY) June 2010		2. REPORT TYPE Final report		3. DATES COVERED (From - To)	
4. TITLE AND SUBTITLE Force Time History During the Impact of a Barge Train with a Lock Approach Wall Using Impact_Force				5a. CONTRACT NUMBER	
				5b. GRANT NUMBER	
				5c. PROGRAM ELEMENT NUMBER	
6. AUTHOR(S) Robert M. Ebeling, Barry C. White, Abdul N. Mohamed, and Bruce C. Barker				5d. PROJECT NUMBER	
				5e. TASK NUMBER	
				5f. WORK UNIT NUMBER	
7. PERFORMING ORGANIZATION NAME(S) AND ADDRESS(ES) U.S. Army Engineer Research and Development Center Information Technology Laboratory 3909 Halls Ferry Road Vicksburg, MS 39180-6199				8. PERFORMING ORGANIZATION REPORT NUMBER ERDC/ITL TR-10-1	
9. SPONSORING / MONITORING AGENCY NAME(S) AND ADDRESS(ES) U.S. Army Corps of Engineers Washington, DC 20314-1000				10. SPONSOR/MONITOR'S ACRONYM(S)	
				11. SPONSOR/MONITOR'S REPORT NUMBER(S)	
12. DISTRIBUTION / AVAILABILITY STATEMENT Approved for public release; distribution is unlimited.					
13. SUPPLEMENTARY NOTES					
14. ABSTRACT To conduct a dynamic structural response analysis of flexible approach walls at Corps locks using structural dynamics engineering computer programs, a force time history is needed to represent the impact of a barge train with the approach wall. This technical report describes an engineering methodology used to create this pulse force time history normal to the wall. This engineering methodology is implemented with a PC-based FORTRAN program and visual modeler named Impact_Force. The engineering formulation for Impact_Force uses existing pulse data or synthetic pulse data and the impulse momentum principle to convert the linear momentum of a barge train into a pulse force time history acting normal to the approach wall. Included in this effort is the interpretation of the results from the 1997 full-scale barge train impact prototype experiments conducted at Old Lock and Dam 2 just north of Pittsburgh, PA, and of the 2008 full-scale barge train impact experiments conducted at Winfield Lock and Dam, Winfield, WV.					
15. SUBJECT TERMS Barge impact Barge train impact		Flexible lock approach wall Force time history Glancing blow		Impact_Force Impulse momentum principle Linear momentum	
16. SECURITY CLASSIFICATION OF:			17. LIMITATION OF ABSTRACT	18. NUMBER OF PAGES	19a. NAME OF RESPONSIBLE PERSON
a. REPORT UNCLASSIFIED	b. ABSTRACT UNCLASSIFIED	c. THIS PAGE UNCLASSIFIED			19b. TELEPHONE NUMBER (include area code)