

Time Dependent Stress and Strain Distribution in a Blastloaded Steelplate

Gerhard H. Guerke
Fraunhofer-Institut fuer Kurzzeitdynamik
Ernst-Mach Institut
Freiburg / Germany

prepared for the 25. Explosives Safety Seminar, 1992

Abstract

The stress and strain distribution in an impulsively blastloaded plate is far from equilibrium. Part of the plate will be elastically strained whilst other part will be strongly plastically deformed. A high explosive (HE) charge, detonating near to a flat steelplate produces an impulsive aerea-load. Stress and strain is time dependend and is different from element to element in the plate. The time-dependend displacement of nodes in the net of finite element calculation and the time dependend stress and strain in elements that correspond to the nodes will be discussed.

Contents

1. Introduction
2. Test Arrangement, Experiments
3. Numerical Calculation
4. Phenomenology of Impulsive Blastloading
5. Stress and Strain in the Plate
6. References

1. Introduction

The designer of blast resistant structures should be aware that in an impulsively blastloaded plate the distribution of stress and strain is far from equilibrium. Static design principles are based on equilibrium and must be used carefully.

A high explosive (HE) charge, detonating near to a plate produces an impulsive aerea-load. An impulse is imparted into the plate and any element of the plate is set into motion. Only a small fraction, in the order of 1% of the kinetic energy, can be transformed into elastic deformation. Most of the kinetic energy must be transformed into plastic deformation. Stress and strain is time dependend and is different from element to element in the plate. An extreme non-equilibrium loading situation was chosen in order to highlight the differences to static loading.

The time-dependend displacement of nodes in the net of finite element calculation and the time dependend stress and strain in elements that correspond to the nodes will be discussed.

Report Documentation Page

*Form Approved
OMB No. 0704-0188*

Public reporting burden for the collection of information is estimated to average 1 hour per response, including the time for reviewing instructions, searching existing data sources, gathering and maintaining the data needed, and completing and reviewing the collection of information. Send comments regarding this burden estimate or any other aspect of this collection of information, including suggestions for reducing this burden, to Washington Headquarters Services, Directorate for Information Operations and Reports, 1215 Jefferson Davis Highway, Suite 1204, Arlington VA 22202-4302. Respondents should be aware that notwithstanding any other provision of law, no person shall be subject to a penalty for failing to comply with a collection of information if it does not display a currently valid OMB control number.

1. REPORT DATE AUG 1992	2. REPORT TYPE	3. DATES COVERED 00-00-1992 to 00-00-1992			
4. TITLE AND SUBTITLE Time Dependent Stress and Strain Distribution in a Blastloaded Steelplate		5a. CONTRACT NUMBER			
		5b. GRANT NUMBER			
		5c. PROGRAM ELEMENT NUMBER			
6. AUTHOR(S)		5d. PROJECT NUMBER			
		5e. TASK NUMBER			
		5f. WORK UNIT NUMBER			
7. PERFORMING ORGANIZATION NAME(S) AND ADDRESS(ES) Fraunhofer-Institut fuer Kurzzeitdynamik,Ernst-Mach Institut,Freiburg / Germany,		8. PERFORMING ORGANIZATION REPORT NUMBER			
9. SPONSORING/MONITORING AGENCY NAME(S) AND ADDRESS(ES)		10. SPONSOR/MONITOR'S ACRONYM(S)			
		11. SPONSOR/MONITOR'S REPORT NUMBER(S)			
12. DISTRIBUTION/AVAILABILITY STATEMENT Approved for public release; distribution unlimited					
13. SUPPLEMENTARY NOTES See also ADA261116, Volume IV. Minutes of the Twenty-Fifth Explosives Safety Seminar Held in Anaheim, CA on 18-20 August 1992.					
14. ABSTRACT see report					
15. SUBJECT TERMS					
16. SECURITY CLASSIFICATION OF:			17. LIMITATION OF ABSTRACT Same as Report (SAR)	18. NUMBER OF PAGES 17	19a. NAME OF RESPONSIBLE PERSON
a. REPORT unclassified	b. ABSTRACT unclassified	c. THIS PAGE unclassified			

2. Test Arrangement, Experiments

A spherical HE-charge (1 kg of PETN) detonates at some distance (HOB) above the center of a square steelplate ($1*1*0.002 \text{ m}^3$). The plate was clamped along all edges to a rigid support. The test arrangement is shown in Figs.2.1 and 2.2 (Ref.1, 2).

A typical experimental result is shown in Figs.2.3 and 2.4. The final shape of the impulsively loaded plate is close to a pyramid, whilst a statically loaded plate results in a near spherical shape. If the final shape is different, there must be a different mechanism of deformation.

The maximum deflection of the plate's centerpoint as a function of the specific blastimpuls (impulse per unit area imparted to the plate) is shown in Fig.2.5. The results from 10 experiments with a plate $1\text{m} * 1\text{m}$ and 2 mm thick and HE-charges at different HOB and 8 results from numerical calculations obviously lie at one straight line. This diagram demonstrates that the DYNA 3D FE-code is suited to describe the large deformation of a steelplate under impulsive loading. More checks were done to confirm this result.

3. Numerical Calculation

The overall deformation of the steelplate, as well as stress and strain in different elements of the steelplate was calculated by means of the DYNA 3D code. Details, how to find the best net-discretisation, to minimize the machine time and to optimize the input- and output procedures can be found in the references 3, 4, 5, 6.

The numerical work with the FE-code can only be successful, if two sets of input parameters are correct:

- the load function in spacial and temporal distribution.
- the material properties.

The input load function was measured carefully with piezoelectric pressure gages at a nonresponding platform (Ref.1). At close-in detonation the spherical shockfront is not flat when it impinges the flat plate. It impinges first at the center of the plate (ground zero) and then spreads to the edges. Different pressure-time histories for up to 20 zones at the plate's surface were determined.

Additional numerical calculation was done for arrangements where no direct comparison with experimental results was planned. Identical input blast parameters had to be used for different arrangements. In that case blast parameters from the literature were taken (Ref.5; 6).

Most of the numerical calculation was done with standard values for the material properties of mild steel under "static" load:

Mass Density	7770	kg / m ³
Modulus of Elasticity	207	GPa
Poisson's Ratio	0.3	
Yield Stress Tension	340	MPa
Yield Stress Shear	195	MPa (0.6 of tension)
Tangent Modulus	68.9	MPa / Strain (m/m)
Temperature	20	degree C

Numerical calculation was done in the field of:

Different HoB for 1 kg HE charges (Ref.1, 4)
Different spatial and temporal pressure distribution at the flat plate for spherical blast (Ref.3, 4)
Centric and excentric detonation (Ref.3)
Square and rectangular plates (Ref.1; 3)
Effect of tension yield stress (525 MPa instead of 340 MPa) (Ref.1)
Effect of tangent modulus (3 GPa instead of 69.9 MPa) (Ref.1)
Effect of stiffeners (Ref.4)
Effect of a girder (Ref.5)
Discretisation of the plate in 2 layers

Results from different reports will be discussed.

4. Phenomenology of Impulsive Blastloading

A high explosive (HE) charge, detonating near a plate produces an impulsive aerea-load. The time-scale of the process generally is milliseconds. The reflected blastpressure at the plates surface rises suddenly to its peak overpressure and decreases to zero in a time that is short relatively to the reaction-time of the plate.

An impulse is imparted into the plate and any element of the plate is set into motion. The plate's mass contains an amount of kinetic energy that must be transformed into deformation. Only a small fraction, in the order of 1% of the kinetic energy, can be transformed into elastic deformation. Most of the imparted energy must be transformed into plastic deformation. The reaction-time is over when all the kinetic energy is transformed and the plate is at rest.

The acceleration, velocity and displacement vs. time of a selected point (node) in the center of the square plate will be discussed. The shape of the plate at different moments of time will be shown as well as the final shape after the loading.

Fig.4.1 The shape of the plates cross-section from the center (left) to the fixed edge in the middle of the span at 500 mm (right) is shown at 4 moments of time after the shock-front arrival (Ref.2). The plate was loaded from above and moves downwards. At 0.125 ms the movement starts with a flat plate. At 0.875 ms the flat bottom has reached a displacement of 30 mm. A "knee" moves along the plate from the fixed edge to the center and causes a rim at constant slope. The section of the plate that was passed by the knee is at rest. The flat bottom moves downwards at constant velocity. It gets smaller with time. At 2.2 ms the knee has reached the plate's center. The whole plate was plastically deformed and is at rest now. This is the end of the reaction time.

Fig.4.2 The final cross-sectional shape of the deformed steelplate for different blastimpulses is shown. The plate was fixed at the left side. Different impulsive load was produced by different distances (HoB) of the HE-charge above the plate. The slope of the rim gets steeper with increasing impulse. The final shape was reached at the same time of 2.2 ms, independently of the load.

Fig.4.3 The center of the square plate was accelerated during the positive pressure duration of 0.22 ms. Maximum acceleration is 58,000 g`s. Acceleration is zero from 0.22 ms to 1.8 ms, when a force acts in the opposite direction. Maximum acceleration in the opposite direction is 36,000 g's at 2.2 ms.

Fig.4.4 A certain amount of kinetic energy was imparted into the plate during the phase of acceleration. We are interested in the mechanism that reduces the kinetic energy. At 2.2 ms, at the end of the reaction time, there is no kinetic energy left, the plate is at rest.

Fig.4.5 The velocity reaches a constant value of 75 m/s at the end of the acceleration phase. The plate's centerpoint moves at constant velocity from 0.22 ms to 1.8 ms and then is rapidly stopped. Zero velocity is reached at 2.2 ms.

Fig.4.6 The centerpoint moves at nearly constant velocity for 2.2 ms where it reaches its maximum displacement of 150 mm. Some relatively small vibrations occur later than 2.2 ms.

The discussion of the diagrams results in the following conception of the deformation mechanism:

The deformation of steelplates at impulsive blastloading happens in the timeframe of milliseconds. An amount of kinetic energy is imparted into the plate and must be transformed into plastic deformation.

Any point of the plate is accelerated during the time of positive pressure duration. Extremely high values of acceleration occur (some 10,000 g's). At the end of the acceleration phase a constant velocity is reached (some 10 m/s). A plastic wave or knee starts in the moment of loading from all fixed edges and runs at constant velocity along the plate to the plate's center (225 m/s). Any point that is caught by the knee will be retarded roughly and comes to rest. Most of the kinetic energy must be transformed in the running plastic knee. The reaction-time is determined by the time that it takes for the plastic wave to run through the material from any fixed edge to the center of the plate.

The mechanism results in a rim at constant slope, that depends on the loading impulse, the mass and the strength of the material. The final shape of the deformed plate is pyramidal.

The mechanism of energy transformation and material deformation results in a spatial and temporal stress and strain distribution in the plate that will be discussed in the following section.

5. Stress and Strain in the Plate

The effect of a blastwave on a steelplate was computed by means of the explicit, 3-dimensional FE-code DYNA 3D (Ref.5, 6). Acceleration, velocity and displacement at different points (nodes) of the plate was calculated as well as the shear stress, the effective stress and the effective plastic strain in corresponding elements.

A spherical 150 kg TNT-charge detonates at a distance of 6 m from a steelplate. The plates dimensions are 7.2m * 2.5m * 0.004m. The blast data are 3.66 MPa reflected peak overpressure, 3 ms positive duration and 2564 Pa*s specific reflected blastimpulse. The yield stress was 340 MPa. Large plastic deformation occurs.

The time-scale is 10 ms in all diagrams shown in this section.

Fig.5.1 A pressure pulse of 3660 kPa peak overpressure and 3 ms positive duration impinges on the flat surface of the plate at time 0. It transfers impulse to the plate and induces the plate to movement. According to its mass and velocity the plate contains kinetic energy that has its maximum at 1.8 ms. The kinetic energy decreases continuously and is near 0 at 6 ms.

Fig.5.2 The effective stress in 3 elements of the plate is shown as a function of time. The element B is situated near to the clamped edge and the element J at the midspan.

It takes 0.2 ms to reach the yield stress near the edge (B) and 1ms at the midspan (J). The stress rises very fast (sub-millisecond) in each element.

The sudden rise of stress starts at different time in the elements from "near zero" stress to yield stress. The "mechanism" that causes the stress to reach yield stress runs with longitudinal acoustic wave velocity (5800 m/s) from the clamped edge to the plate's center.

In all three elements the stress remains constant at a "yield stress plateau" for a period of time. The moment of time is marked by an arrow when the stress in an element exceeds the yield stress. This happens first at the clamped edge (B) and 2ms later at the midspan (J). **There must be a "mechanism" that causes the stress to exceed yield stress at different moment of time in different elements.**

When the Kinetic energy returns to zero ($KE = 0$ at 6 ms) the effective stress in the elements decreases below yield stress.

Fig.5.3 The time history of the shear stress in the elements is nearly identical to the effective stress. Shear yield stress was taken as 0.6 times the tension yield stress. **Shear stress is an important parameter in the deformation mechanism of the steelplate.**

Fig.5.4 Effective plastic strain arises in an element at the time when the stress exceeds yield stress in this element. The time to reach the maximum strain is different in the elements.

The strain rate in m/m/s can be calculated and is different in the elements.

When the Kinetic energy returns to zero ($KE = 0$ at 6 ms) the plastic strain in the elements has reached its maximum and constant value.

Fig.5.5 and 5.6 Stress and strain in 4 elements along the short fixed span are shown. The strain exceeds the yield stress at the same moment in all the elements. Highest stress arises in the middle of the span (A). In the corner (I) the stress exceeds yield stress marginally. The plastic strain is marginal in the corner (I, 0.25%) and maximum in the middle (A, 4.2%). Strain at the short span is smaller than at the long span (see Fig.5.4, Element B).

Fig.5.7 The maximum strain in an element is directly proportional to the maximum stress in the element. The stress-time history does not have an effect on the final plastic strain.

6. References

1. Guerke, G. H. Buecking, P.W. et al. (1987), "Experimentelle Untersuchungen zum Versagen schifftechnischer Bauteile unter Blastbelastung," (Experimental investigation of dynamic-plastic response of steel-plates to impulsive blast load), Report No. E 7/87, Jun. 1987 Ernst-Mach-Institut, Freiburg, Germany.
2. Guerke, G. H. (1987), "Dynamic-Plastic Response of Steelplates to Blastload", MABS 10.
3. Buecking, P. W. (1989), "Numerische Simulation der Druckstoßwirkung zentrischer und exzentrischer Nahbereichsexplosionen auf eingespannte quadratische und rechteckige Stahlplatten," (Numerical simulation of blasteffects from centric and non-centric HE-detonations to clamped square and rectangular steelplates), Report No. 10/89, Nov. 1989, Ernst-Mach-Institut, Freiburg, Germany.
4. Buecking, P. W. (1990), "Numerische Simulation der Druckstosswirkung zentrischer Nahbereichsexplosionen auf eingespannte quadratische Stahlplatten", (Numerical Simulation of blasteffects from centric HoB detonation on clamped square steelplates), Report No. 6/90, Jun. 1990, Ernst-Mach-Institut, Freiburg, Germany.
5. Buecking, P. W. (1990), "Numerische Simulation der Druckstoßwirkung einer detonierenden Sprengstoffladung auf eine versteifte Schiffstruktur (Außendetonation)," (Numerical simulation of blasteffects from a detonating HE-charge to a stiffened ship structure, outside detonation), Report No. 7/90, Aug. 1990, Ernst-Mach-Institut, Freiburg, Germany.
6. Buecking, P. W. (1990), "Numerische Simulation einer detonierenden Sprengstoffladung auf eine versteifte Schiffstruktur mit verbesserter dynamischer Strukturfestigkeit (Außendetonation), (Numerical simulation of blasteffects from a detonating HE-charge to a stiffened ship structure with improved dynamic resistance, outside detonation), Report No. 8/90, Aug. 1990, Ernst-Mach-Institut, Freiburg, Germany.
7. Baker, W. E. et al. (1983) "Explosion Hazards and Evaluation", Elsevier Scientific Publishing Company, Amsterdam-Oxford-New York.
8. "Structures to Resist the Effects of Accidental Explosions" (1990), TM 5-1300.
9. "Fundamentals of Protective Design for Conventional Weapons" (1989), TM5-855-11.

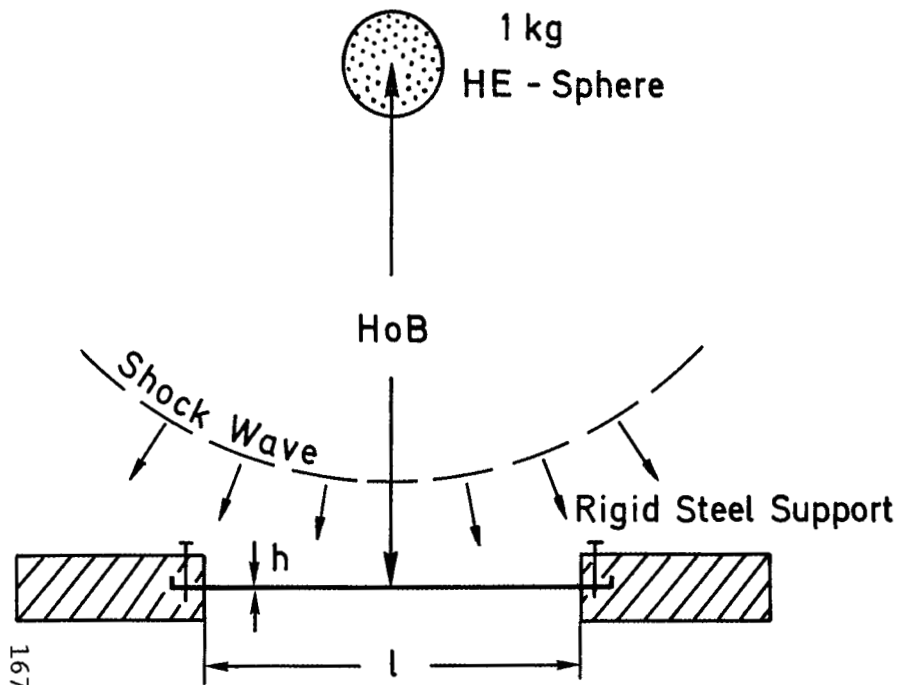

Fig.1 Test Arrangement:
Clamped Quadratic Steel Plate
Parameters:
Plate Side Length l
Plate Thickness h
Charge Height HoB

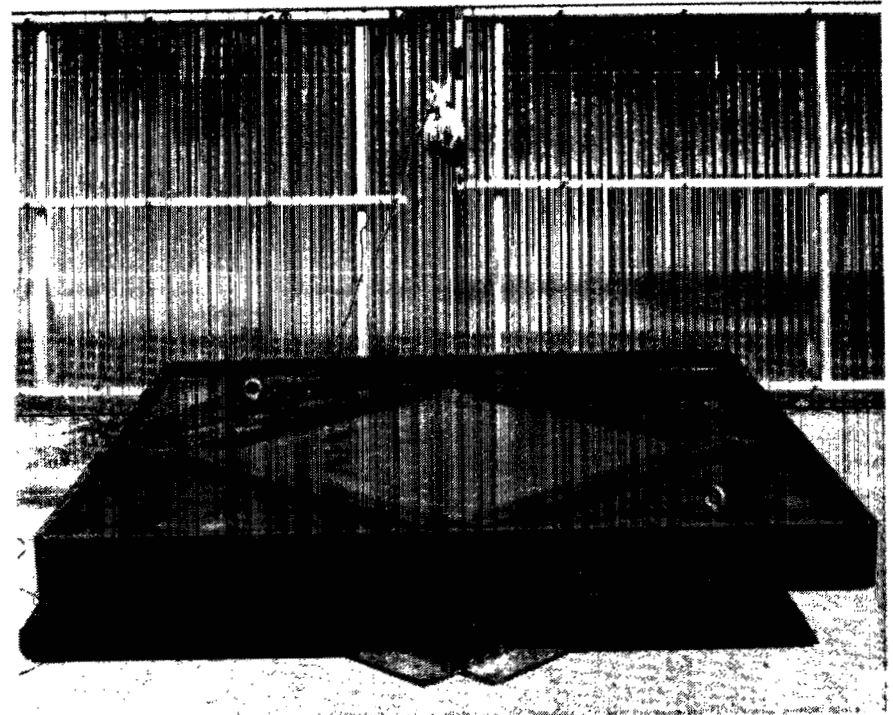

Fig. 2 The test arrangement - a flat square steelplate $1m \cdot 1m$ clamped and bolted to a rigid support. The 1kg charge made of plastic explosive is wrapped into thin fabric and detonated at some height above the plate center.

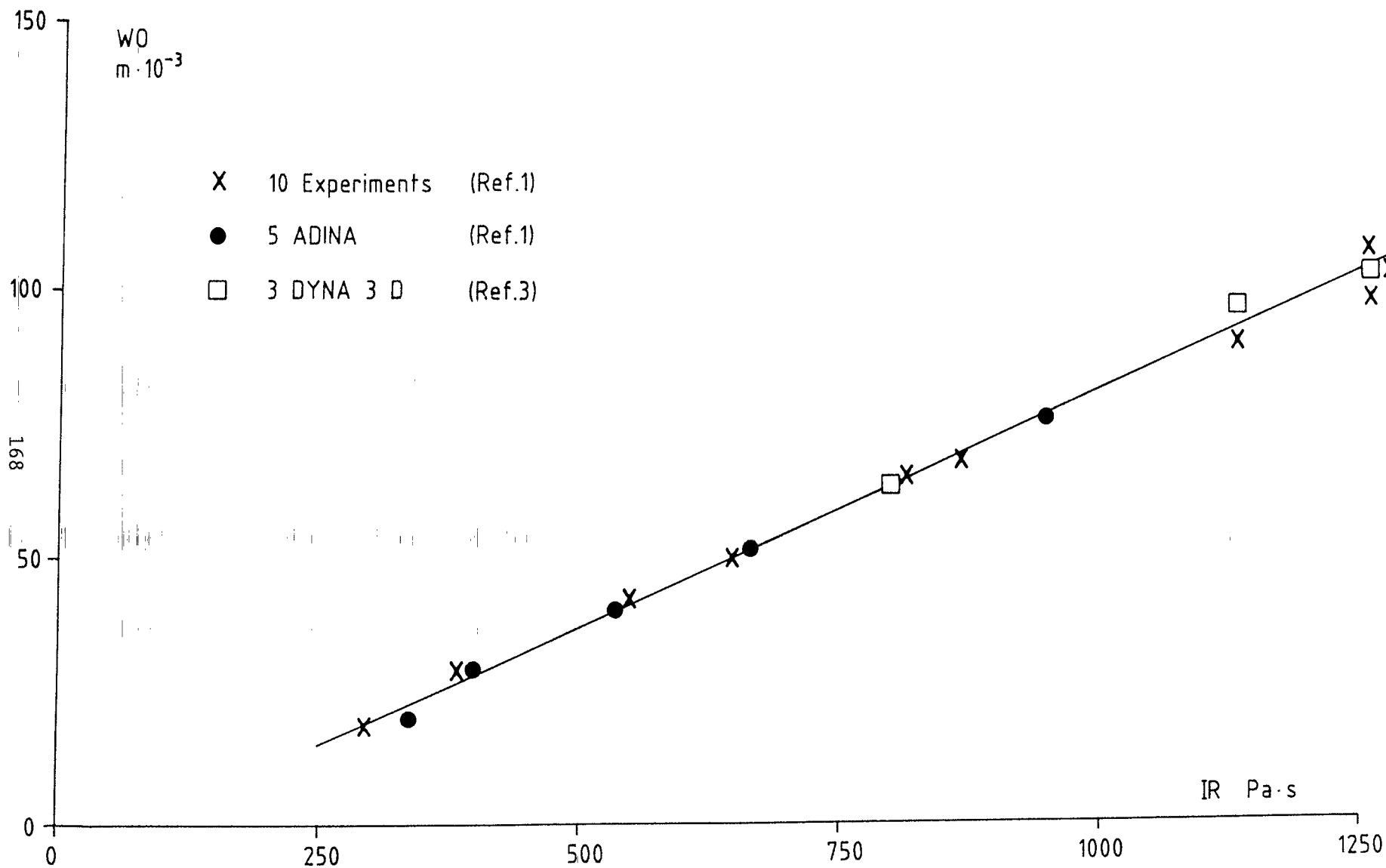
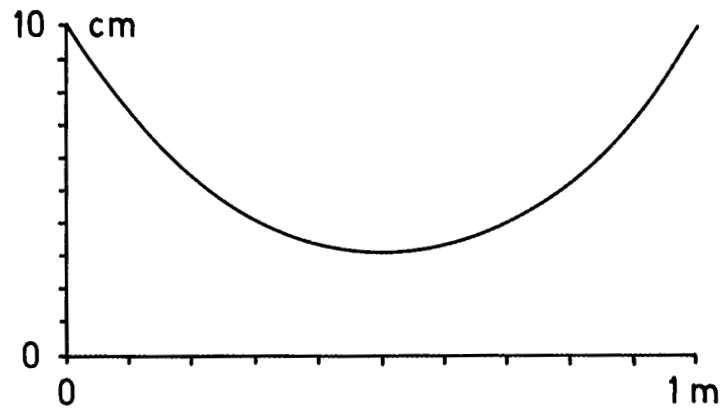
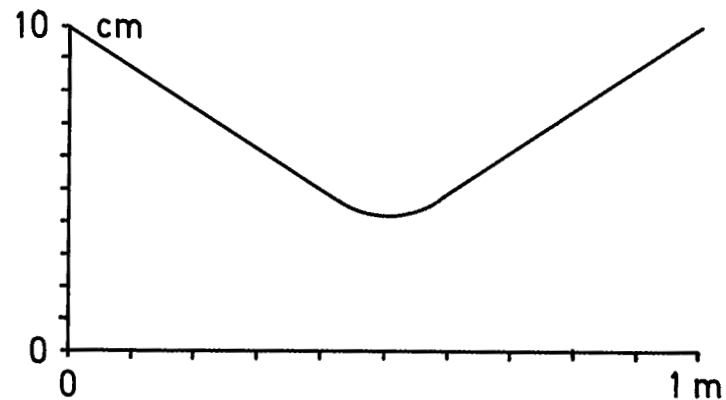

Fig.2.5

Permanent Deformation vs Specific Blastimpuls



static loading



impulsive loading

Fig. 3 Typical Shape of Homogeneous Steel Plates at Static and Impulsive Loading

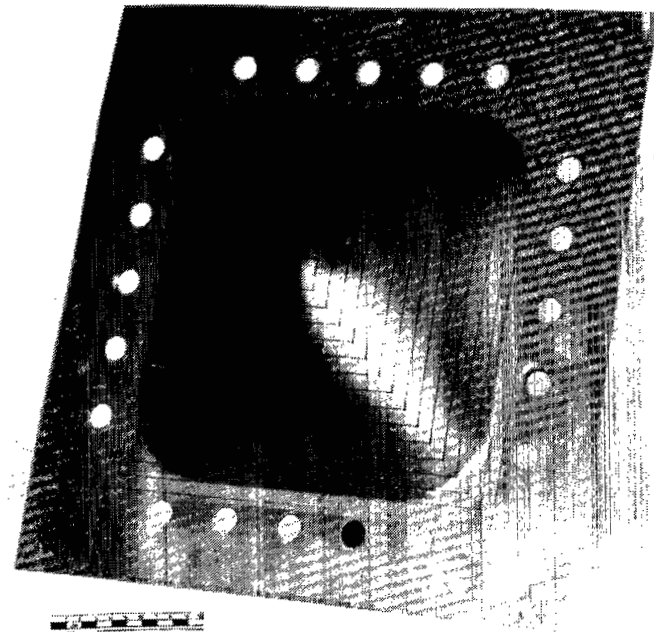

Fig. 4 A clamped square steelplate deforms to a pyramid at high impulsive loading. The straight line pattern at the flat plate remains straight at the pyramid after deformation.

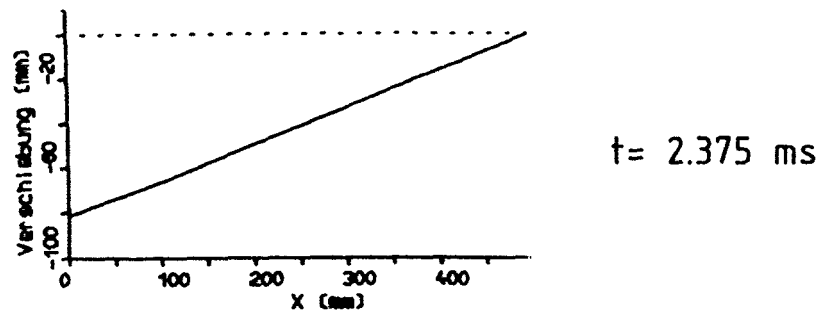
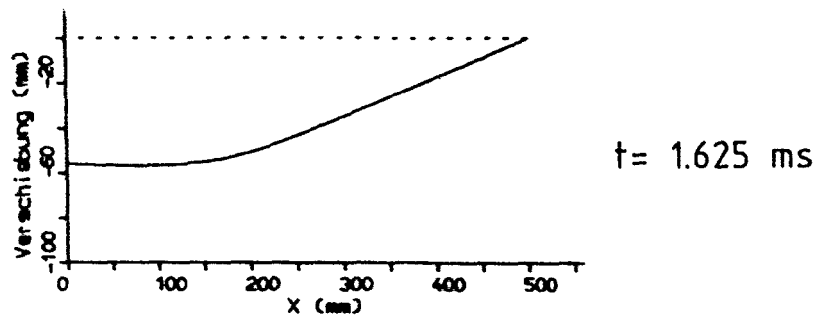
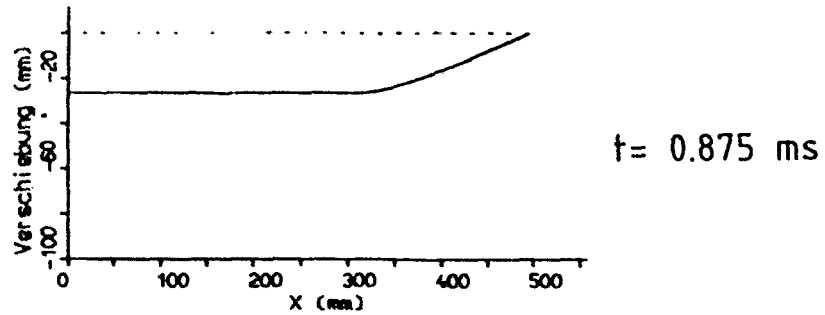
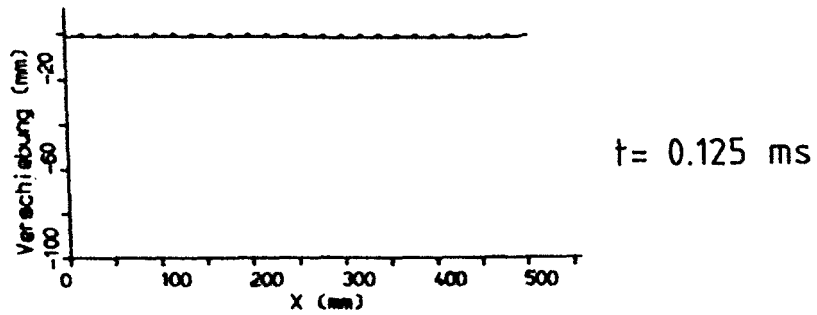
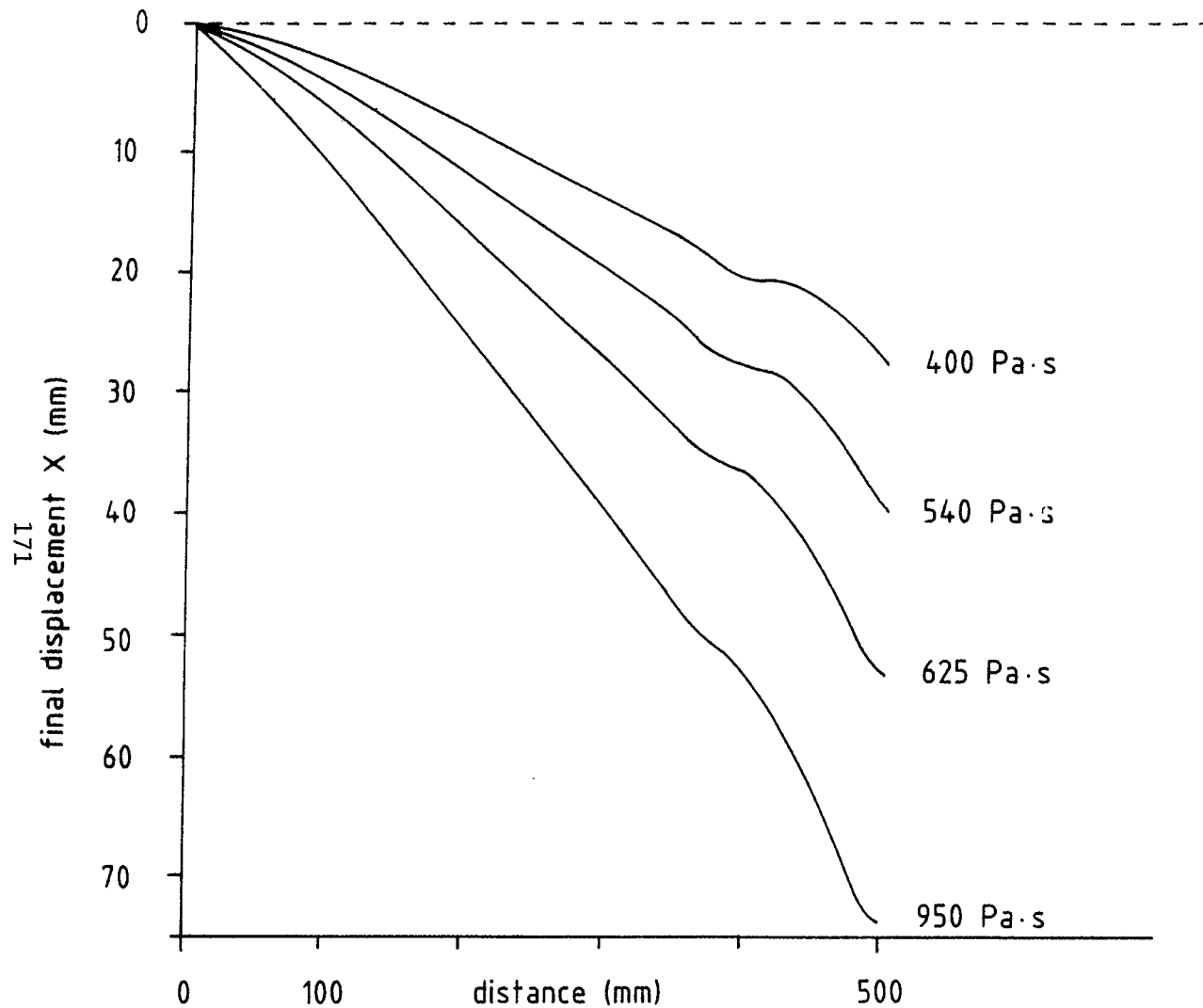

Fig.4.1 The displacement of the plate's cross-section from the centerpoint to one clamped side at different instants of motion.



IR Pa·s	T + ms	X mm	v _c m/s
400	1	29	30
540	0.55	40	40
625	0.35	52	50
950	0.2	73	70

Fig.4.2 Final Shape of the Deformed Steelplate at Different Blastload
 Square Steelplate 1x1 m²; 0.002 m thick
 Final Position at 2.2 ms; Plastic Wave Velocity 225 ms⁻¹

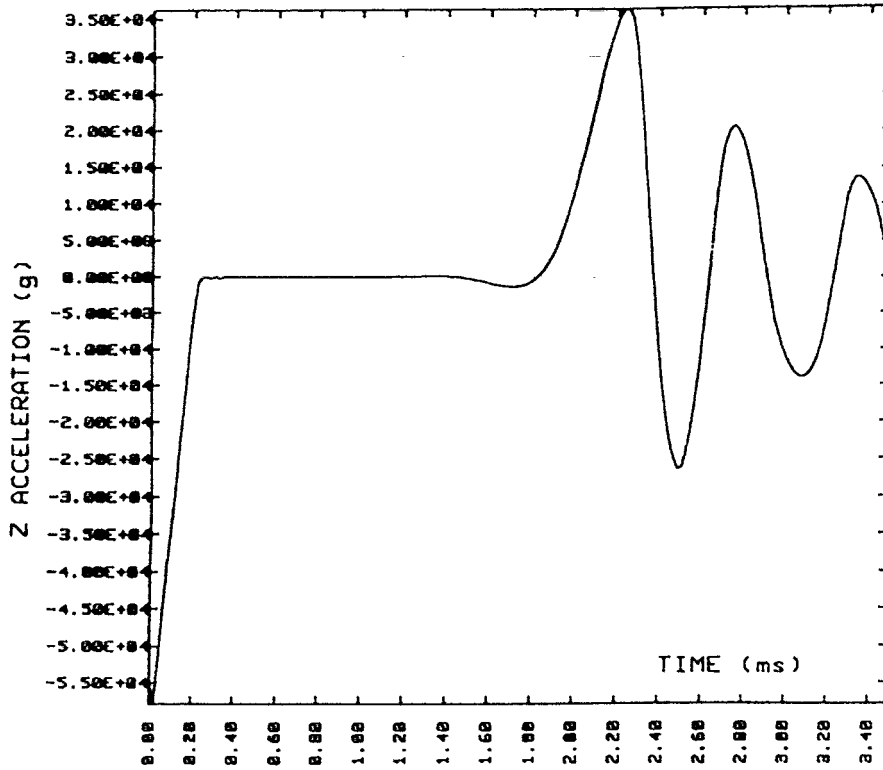

Fig.4.3 Acceleration vs Time
Centerpoint of a Blastloaded Square Steelplate

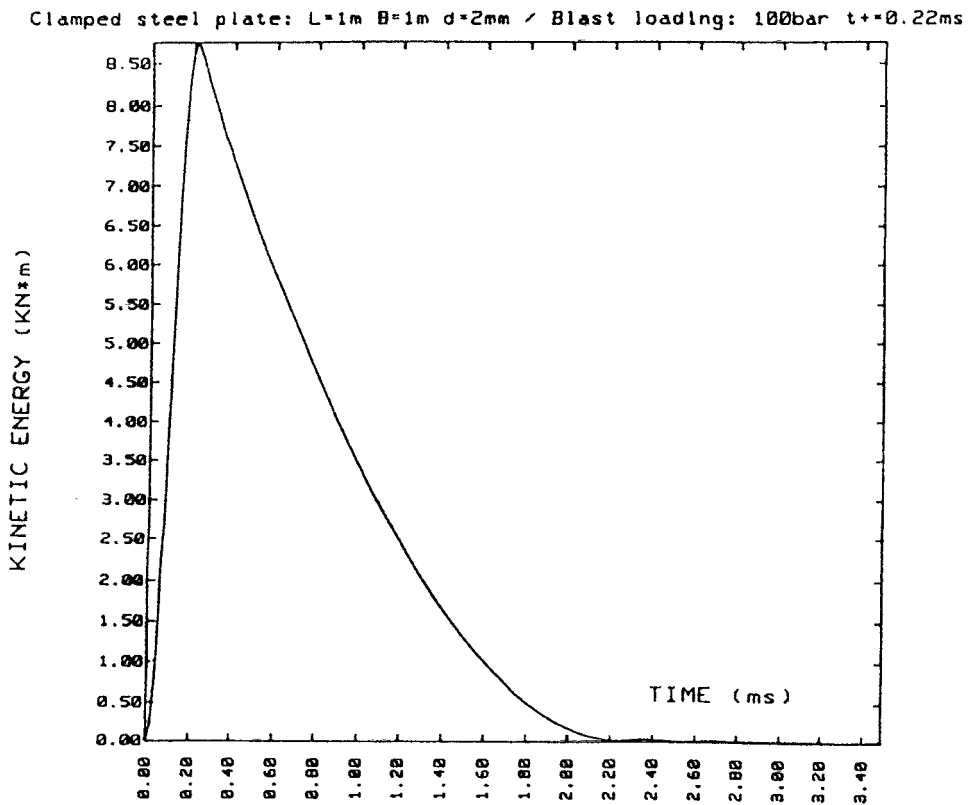

Fig.4.4 Kinetic Energy vs Time
Centerpoint of a Blastloaded Square Steelplate

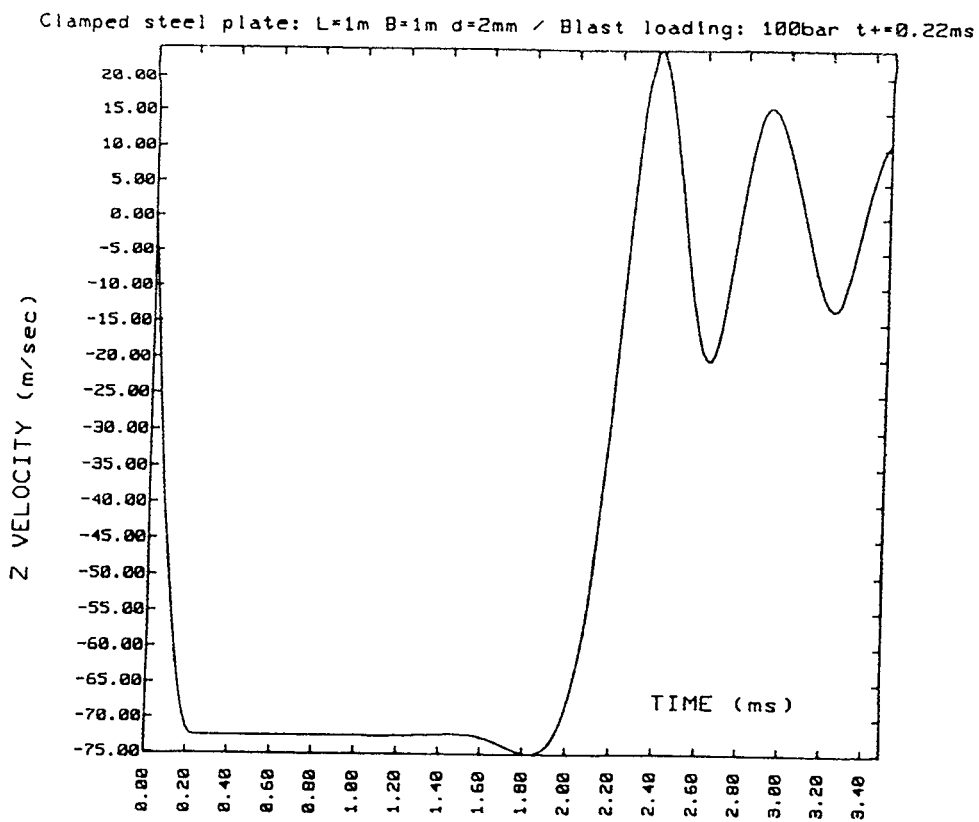

Fig.4.5 Velocity vs Time
Centerpoint of a Blastloaded Square Steelplate

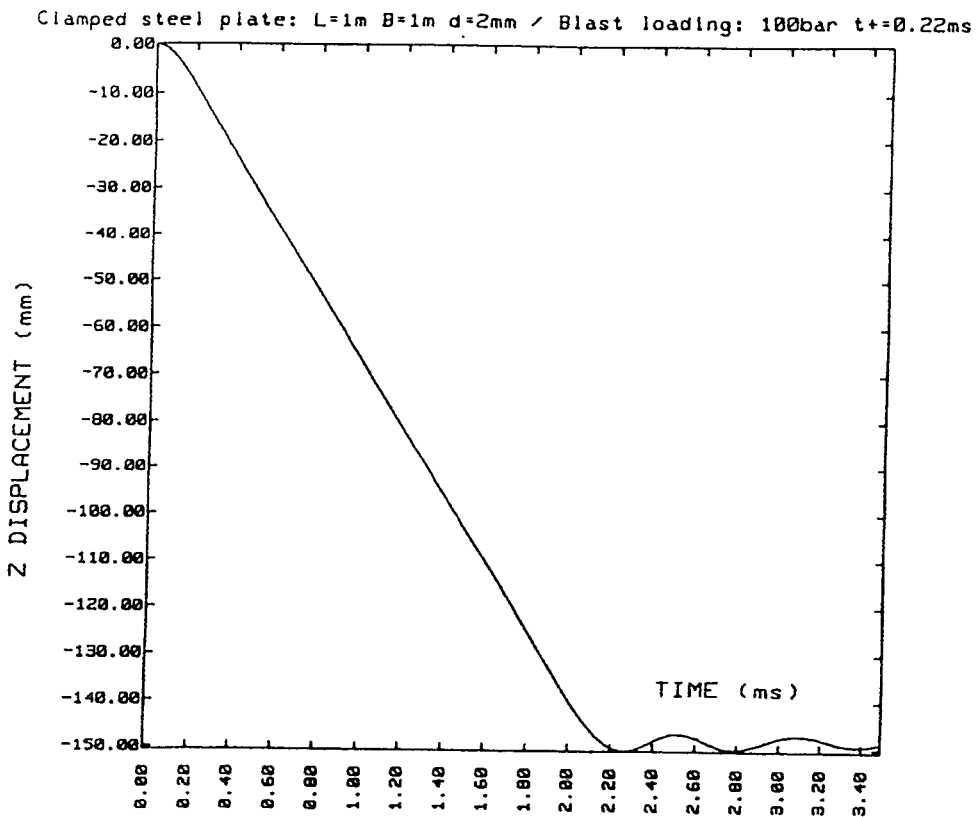

Fig.4.6 Displacement vs Time
Centerpoint of a Blastloaded Square Steelplate

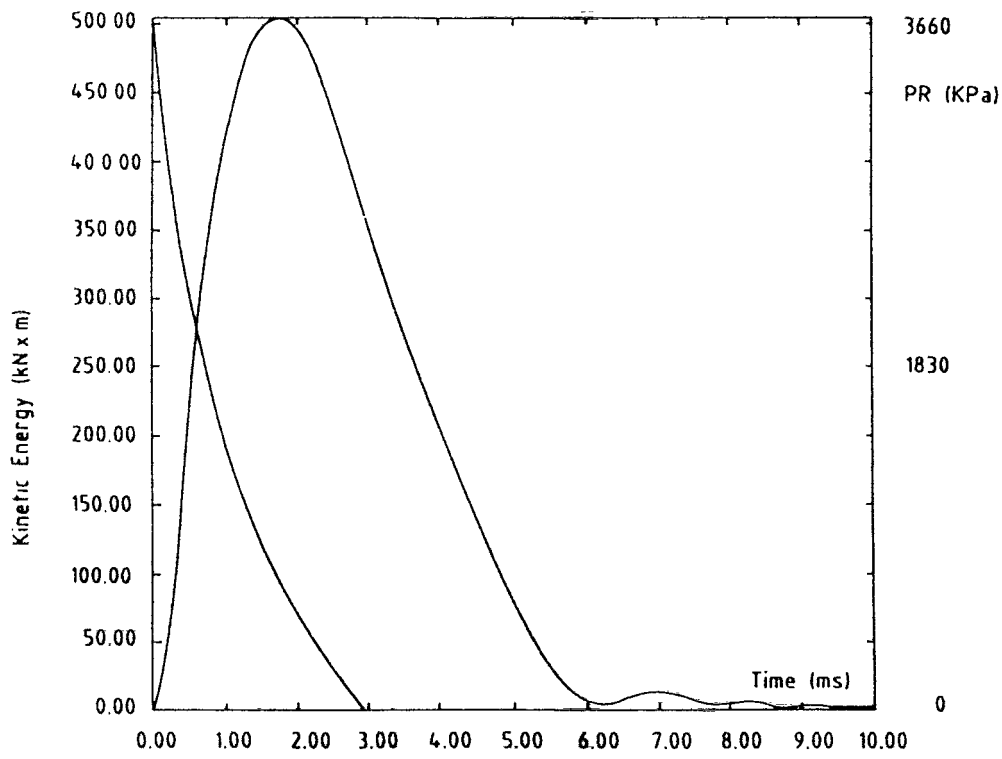

Fig.5.1 Pressure Pulse and Time History of the Kinetic Energy in the Plate

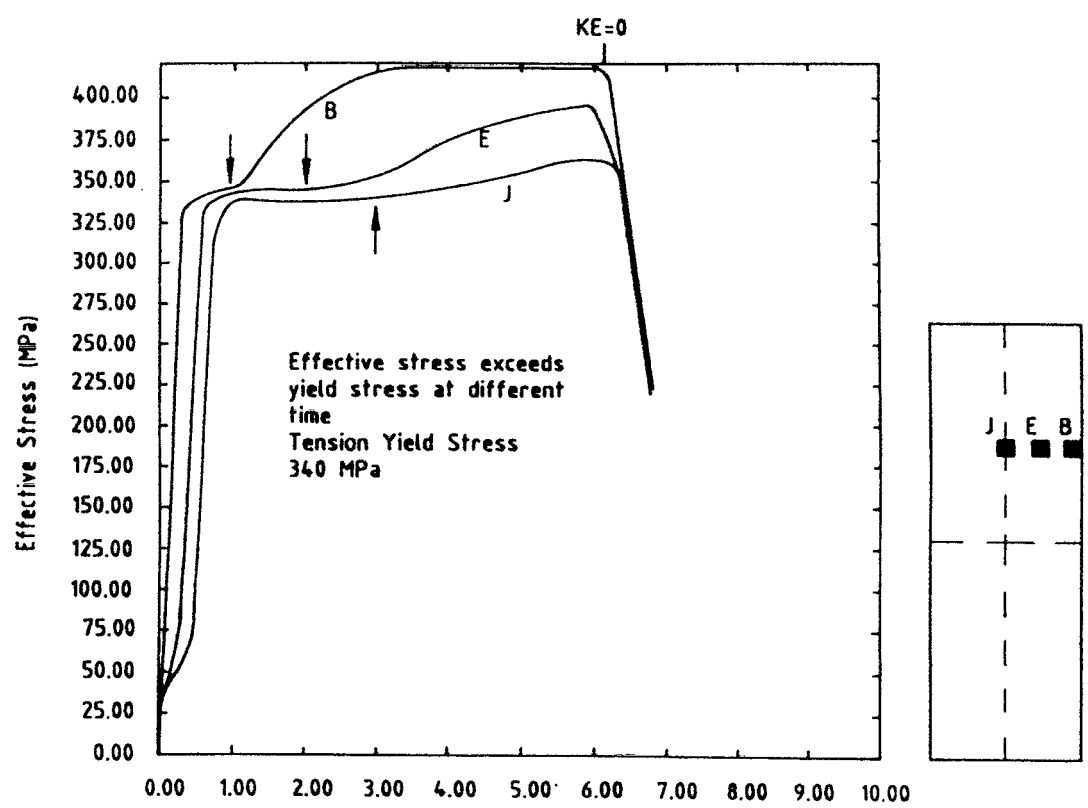

Fig.5.2 Effective Stress in 3 Elements
 Element B - near the edge
 Element J - at midspan

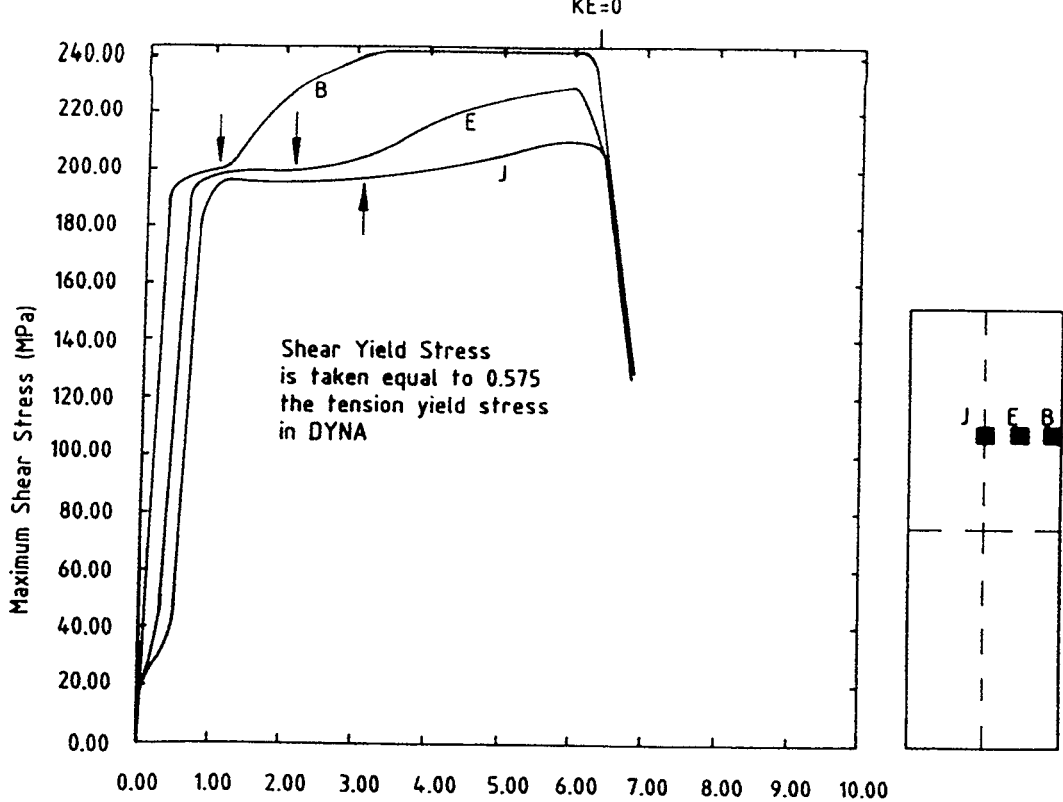

Fig.5.3 Shear Stress in 3 Elements
Element B - near the edge
Element J - at midspan

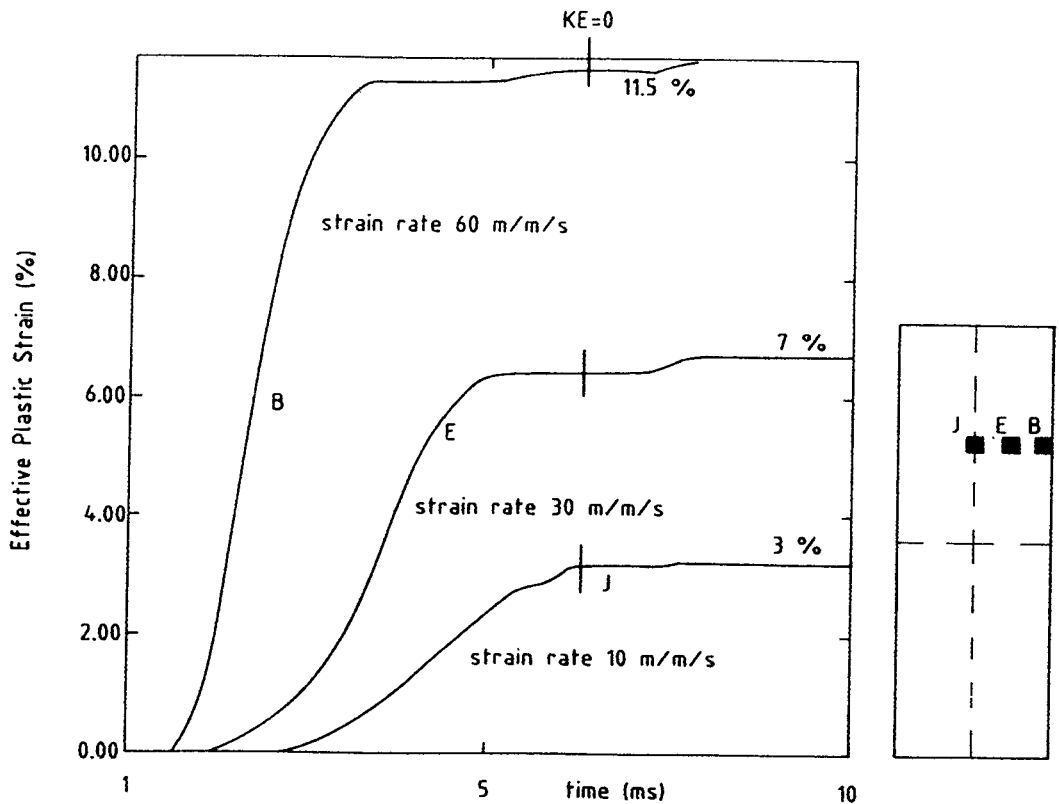

Fig.5.4 Effective Plastic Strain (%) in 3 Elements
Element B - near the edge
Element J - at midspan

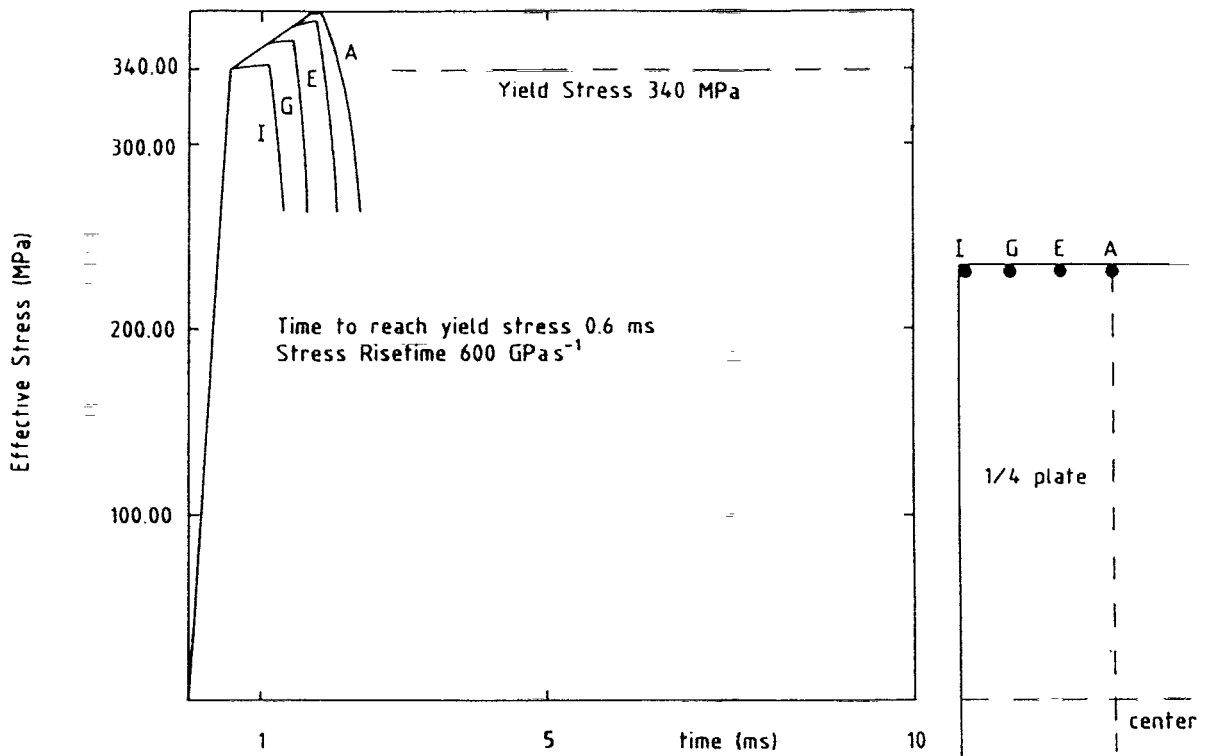

Fig.5.5 Effective Stress vs Time
Four Elements along the clamped edge

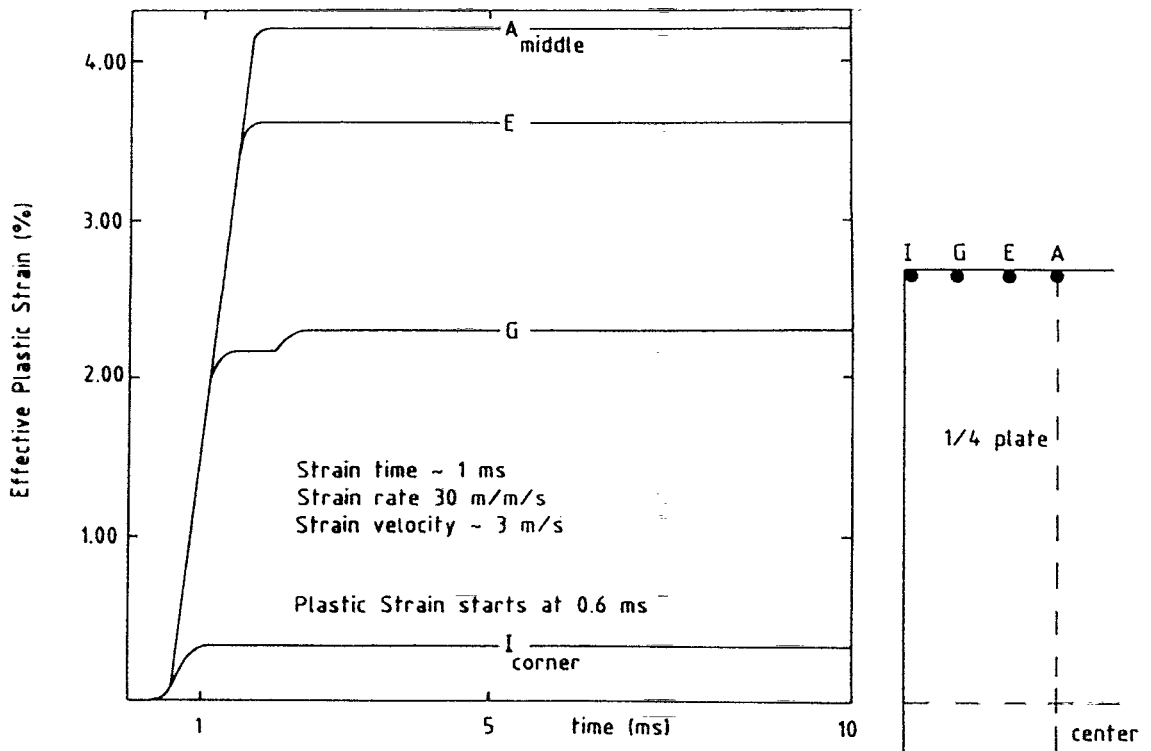

Fig.5.6 Effective Plastic Strain (%) vs Time
Four Elements along the clamped edge

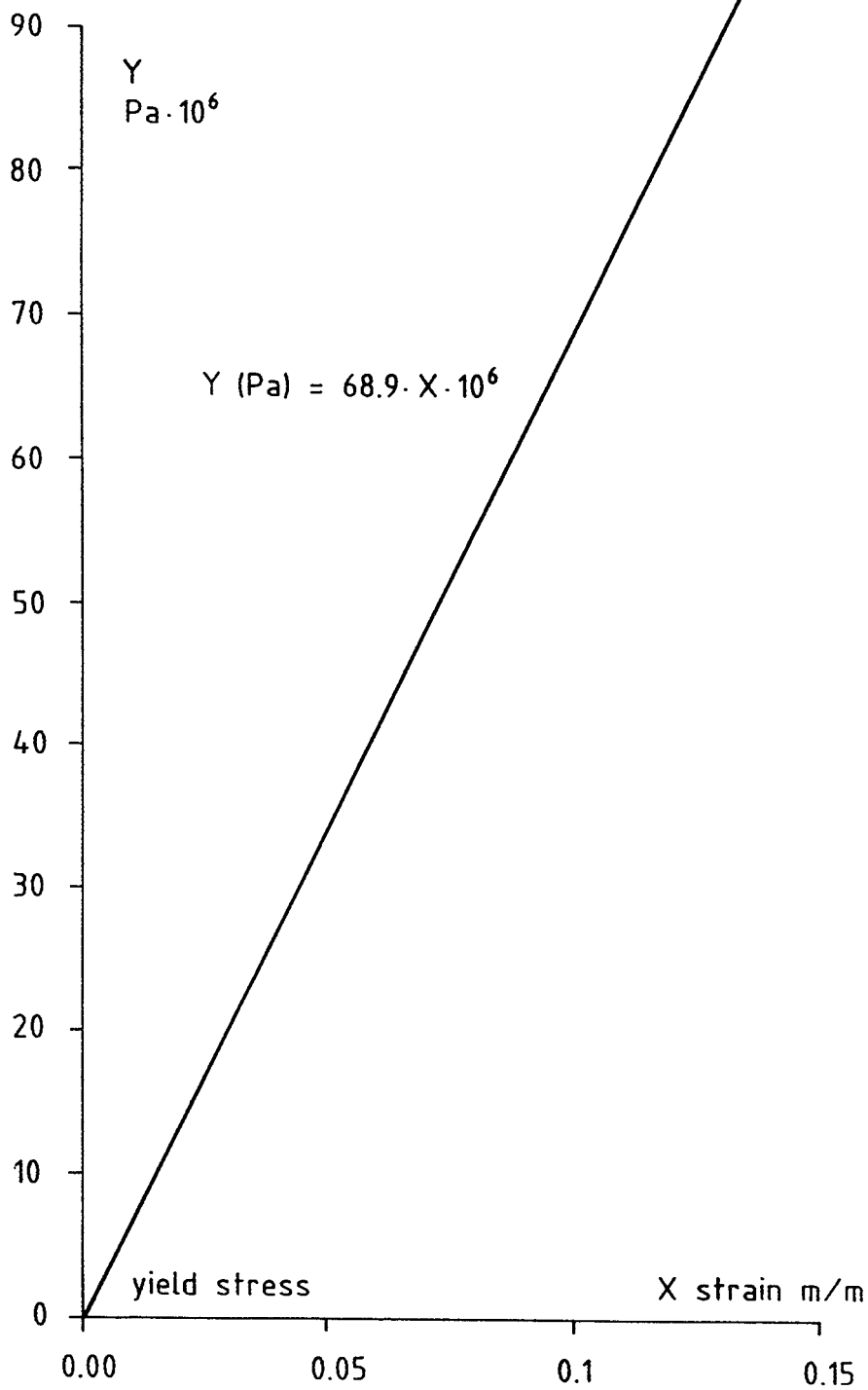

Fig.5.7 stress exceeding yield stress vs permanent strain (DYNA)