

# **DEFLAGRATING MUNITIONS AND THE MASS DETONATION HAZARD**

**M. Chick, T.J. Bussell, D. McQueen and L. McVay**

**DSTO  
Materials Research Laboratory,  
Melbourne, Australia**

**TWENTY FIFTH DOD EXPLOSIVES SAFETY SEMINAR  
ANAHEIM, CALIFORNIA, USA  
18-20 AUGUST 1992**

# Report Documentation Page

*Form Approved  
OMB No. 0704-0188*

Public reporting burden for the collection of information is estimated to average 1 hour per response, including the time for reviewing instructions, searching existing data sources, gathering and maintaining the data needed, and completing and reviewing the collection of information. Send comments regarding this burden estimate or any other aspect of this collection of information, including suggestions for reducing this burden, to Washington Headquarters Services, Directorate for Information Operations and Reports, 1215 Jefferson Davis Highway, Suite 1204, Arlington VA 22202-4302. Respondents should be aware that notwithstanding any other provision of law, no person shall be subject to a penalty for failing to comply with a collection of information if it does not display a currently valid OMB control number.

1. REPORT DATE <b>AUG 1992</b>	2. REPORT TYPE	3. DATES COVERED <b>00-00-1992 to 00-00-1992</b>			
4. TITLE AND SUBTITLE <b>Deflagrating Munitions and the Mass Detonation Hazard</b>		5a. CONTRACT NUMBER			
		5b. GRANT NUMBER			
		5c. PROGRAM ELEMENT NUMBER			
6. AUTHOR(S)		5d. PROJECT NUMBER			
		5e. TASK NUMBER			
		5f. WORK UNIT NUMBER			
7. PERFORMING ORGANIZATION NAME(S) AND ADDRESS(ES) <b>DSTO, Materials Research Laboratory, Melbourne, Australia,</b>		8. PERFORMING ORGANIZATION REPORT NUMBER			
9. SPONSORING/MONITORING AGENCY NAME(S) AND ADDRESS(ES)		10. SPONSOR/MONITOR'S ACRONYM(S)			
		11. SPONSOR/MONITOR'S REPORT NUMBER(S)			
12. DISTRIBUTION/AVAILABILITY STATEMENT <b>Approved for public release; distribution unlimited</b>					
13. SUPPLEMENTARY NOTES <b>See also ADA261116, Volume IV. Minutes of the Twenty-Fifth Explosives Safety Seminar Held in Anaheim, CA on 18-20 August 1992.</b>					
14. ABSTRACT <b>see report</b>					
15. SUBJECT TERMS					
16. SECURITY CLASSIFICATION OF:			17. LIMITATION OF ABSTRACT <b>Same as Report (SAR)</b>	18. NUMBER OF PAGES <b>13</b>	19a. NAME OF RESPONSIBLE PERSON
a. REPORT <b>unclassified</b>	b. ABSTRACT <b>unclassified</b>	c. THIS PAGE <b>unclassified</b>			

## Abstract

We have previously reported that collisions, impacts and fragment strikes resulting from violently deflagrating 105 mm shell did not produce detonation of neighbouring rounds and thus were unlikely to be the cause of a mass detonation hazard. This paper reports an extension of that work using 81 mm mortar as a representative thin skinned munition, further tests with 105 mm shell and the determination of parameters that define the behaviour of the violently deflagrating donor. Some tests were conducted with a mixture of the two types of munitions using a 105 mm shell as the deflagrating donor and the 81 mm mortar as acceptors; this was to investigate the effect of larger, thicker fragment strikes on cased ordnance. The investigation relates to the conditions that may be encountered during the storage, transportation and deployment of munitions. All rounds were filled with Composition B.

The investigation did not isolate any process that was likely to be the direct cause of escalating a deflagrating reaction to a mass detonation hazard in a stack of similar munitions. However results from the mixed munition array tests suggests further work to investigate the effect of large, thick fragment impacts on thin cased, damaged fillings. There is some evidence that nose end plugs produce a confinement effect on the deflagration reaction.

## **1.0 INTRODUCTION**

There is convincing evidence [1,2] that mass detonations can result from reactions other than the shocks generated by detonating rounds. In this context Frey and Trimble [3] have demonstrated that non-detonative reactions can propagate through Composition B fillings at up to 2.5 km/s in experimental, tubular assemblies. These reactions are subsonic but close to the shock velocity threshold (bulk sound speed ~2.6 to 2.7 km/s) and thus may be considered to produce the most hazardous effects (fragmentation, overpressure/adjacent shell projection) next to those from a detonating round. We have developed and reported [4] a technique that can produce a predetermined deflagration rate in an explosive filled munition that covers the velocity range from 2.0 km/s up to the bulk sound velocity without a transition to detonation occurring. The development of this technique has enabled a study of the processes that may be considered as candidates in escalating a non-detonative reaction into a mass detonation.

We have previously reported [5] on the first part of the study which used 105 mm shell as representative thick cased munitions. This showed that violently deflagrating 105 mm donor shell did not produce detonation of neighbouring rounds by direct fragment strike, inter-round collisions and single and multiple impacts of projected receptors onto hard surfaces.

This paper reports another stage of the investigation which covered the use of 81 mm mortars as representative thin skinned munitions, further tests with 105 mm shell and the determination of parameters that define the behaviour of the violently deflagrating donor round. All rounds were filled with Composition B. The tests with munition arrays relate to the conditions that may be encountered during the storage, transportation and deployment of munitions.

## **2.0 CONTROLLED DEFLAGRATION FOR MASS DETONATION HAZARD ASSESSMENT**

### **2.1 Technique for Producing Controlled Deflagration of Munitions**

The technique for producing violently deflagrating munitions is described in detail in references [4] and [6] and is summarised as follows. A shaped charge jet is fired along the axis of the munition with a velocity below the threshold to produce detonation of the filling. In this way the reaction produced in and behind the bow wave set-up in front of the penetrating jet sweeps through the length of the filling leaving no bulk explosive for a deflagration to detonation transition. Detonation does not result directly from the bow wave since the pressure-time profile is subcritical [7].

The application of the technique to a Composition B filled 105 mm HE M1 donor shell is shown in Figure 1. The baffle was incorporated in the set-ups that used high speed photography to record the characteristics of the deflagrating munition. The baffle prevented reaction products from the shaped charge device from obscuring the image of the shell. A witness block acted as a check for the type of reaction of the shell filling; a deflagration produced only superficial marks on the surface while a detonation produced a well formed dent with sharp edges. The MRL 38 mm diameter shaped charge was used in the tests since there is a considerable data base on its effect on munition fillings [7,8]. The selected subcritical jet velocity was produced by firing the jet at 2 charge diameters standoff through a steel barrier of appropriate thickness placed in contact with the base of the shell. The jet penetration velocity through the filling can be varied by adjusting the thickness of added steel; this is calculated using the method detailed elsewhere [4,6]. The preselected thickness is based on the requirement to erode a sufficient portion of the front of the jet so that the velocity of the tip that enters the filling is at the required value. In the majority of these experiments the total steel thickness (barrier, baffle, shell base) was calculated to be 93.5 mm to give the selected jet penetration velocity in the filling of 2.5 km/s. Since the jet penetration bow wave is coupled to the jet and reactions occurs within the bow wave, it is assumed that the deflagration velocity has a similar value.

## 2.2 Characterisation of Deflagrating Munitions

The characteristics of the deflagrating munitions were recorded with a rotating high speed camera by the method described in detail in reference 6. The framing rate of 35,000 to 40,000 frame/s gave an exposure time per frame and an interframe time of about 2.7  $\mu$ s and 25  $\mu$ s respectively.

Parameters selected to characterise the deflagrating munitions were; case expansion rate, initial fragment velocity, time to case burst, time to reaction from the nose end and the deflagration rate of the filling, see Figure 2. Values for these parameters for the 105 mm shell are given in Table 1. Results from the 81 mm mortar are not included since early case breakup limited the data extracted from the high speed camera records. The listed times were taken from the detonator firing pulse. The times from jet entry into the Composition B filling are 55  $\mu$ s less than these values; this is the estimated time for the functioning of the shaped charge device and for the jet to travel across the standoff distance and penetrate through the steel into the filling. Deflagration commencement was assumed to coincide with jet entry into the explosive. The fragment velocities are taken as half the final case expansion velocities. The first sign of products escaping from the case was taken as the onset of case burst. Products escaping from the fracturing case eventually obscured the photographic image and this was the limiting factor in the measurements, in some tests this precluded an estimate of some data. The limit on the accuracy of the time is the interframe time of about 25  $\mu$ s.

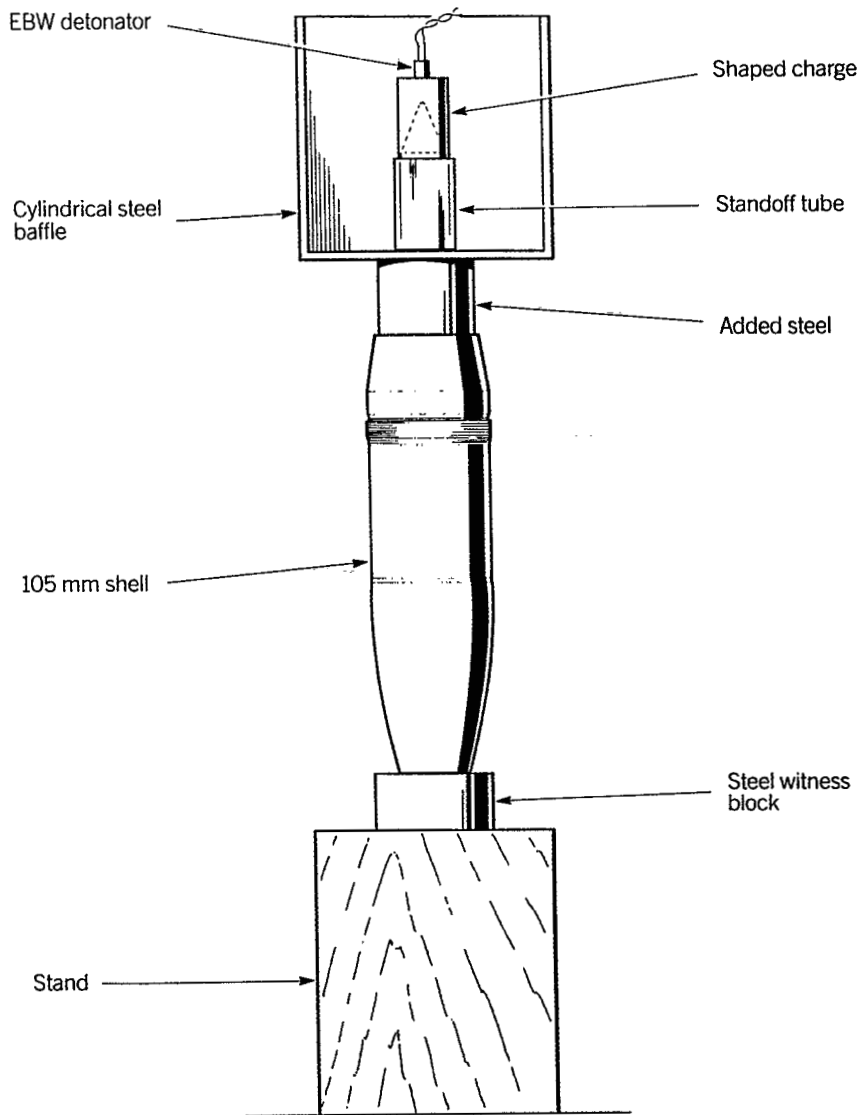

FIGURE 1

Experimental set-up for the controlled  
deflagration of a 105 mm shell

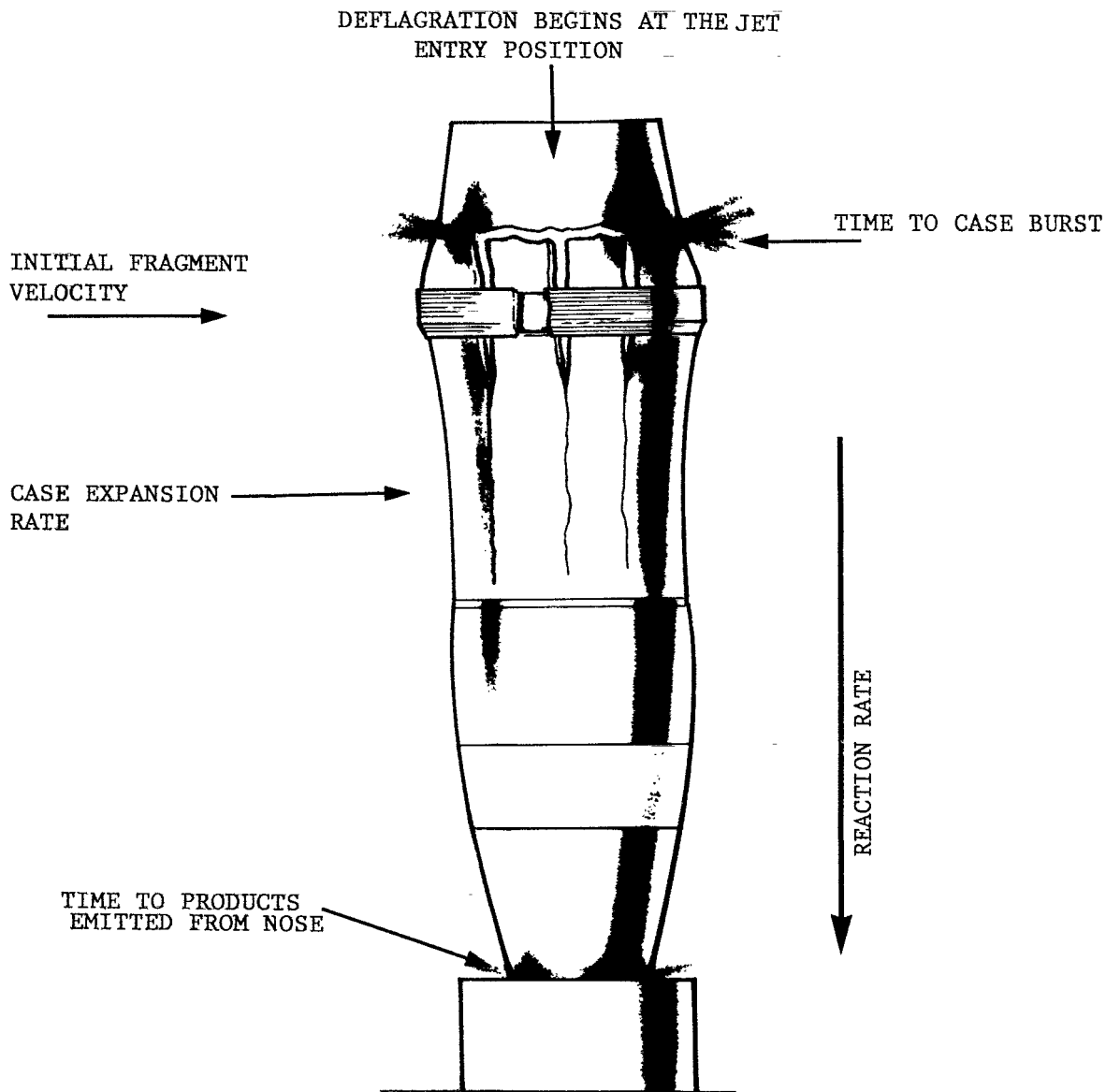

FIGURE 2

Parameters selected to characterise a deflagrating munition

Time to signs of reaction from the nose end and the time to case burst were used to assess the effects of the confinement provided by plugs that represented fuzes (PRF) and transit plugs. The use of a PRF rather than a fuze avoided complications from the effects of the jet and/or reaction on the booster and explosive components in the fuze. Case expansion rate and initial fragment velocity were used to assess the effects of impacts from the deflagrating donor shell case on neighbouring rounds. The deflagrating rate was estimated from the measurement of the time to the onset of case expansion at several positions along the length of the munition. Reference to Table 1 shows that the measured values are in reasonable agreement to the preset calculated values.

Figure 3 shows a representative high speed camera film sequence of a deflagrating unplugged 105 mm shell that corresponds to shot 1 in Table 1. The jet deflagration device was fired from the top of the picture. The baffle around the shaped charge device prevents the detonation products from the shaped charge device from obscuring the view of the shell. Three frames from the start of the sequence in Figure 3, reaction products can be observed escaping from the nose end of the shell; this is followed five frames later by products escaping from the fracturing case in the region of the driving band. Graphical representation of case expansion data for the 105 mm unplugged shell is given in Figure 4. The three curves correspond to three positions on the shell case; the first point was 120 mm from the base just below the driving band, the second was 180 mm from the base near the mid length position and the third was 240 mm from the base near the booster cavity. Shell expansion prior to breakup was about 30% of the initial diameter (ie 15 mm increase in the shell radius).

### **3.0 HAZARD ASSESSMENT OF DEFLAGRATING DONORS IN MUNITION ARRAYS**

#### **3.1 105 MM HE Shell**

We have previously reported [5] on candidate processes by which a deflagrating donor Composition B filled 105 mm HE shell may produce a mass detonation hazard. The 105 mm shell was taken as a representative thick cased munition. The study showed that deflagrating donors did not produce detonation of neighbouring rounds by direct fragment strike, inter-round collisions, single and repeated impacts of projected shell onto hard surfaces and transient interactions in a shell filling induced by near simultaneous collisions.

The data in Table 1 indicates that initial case fracture of the 105 mm shell occurred earlier for the plugged than for the unplugged rounds. This suggests that product pressure build-up may have influenced the process. However Table 1 data also suggests that any confining effect by the plug may not have been translated into higher case expansion and fragment velocities although the fragment velocity data is limited. In order to assess the role of plugged donor rounds and to investigate

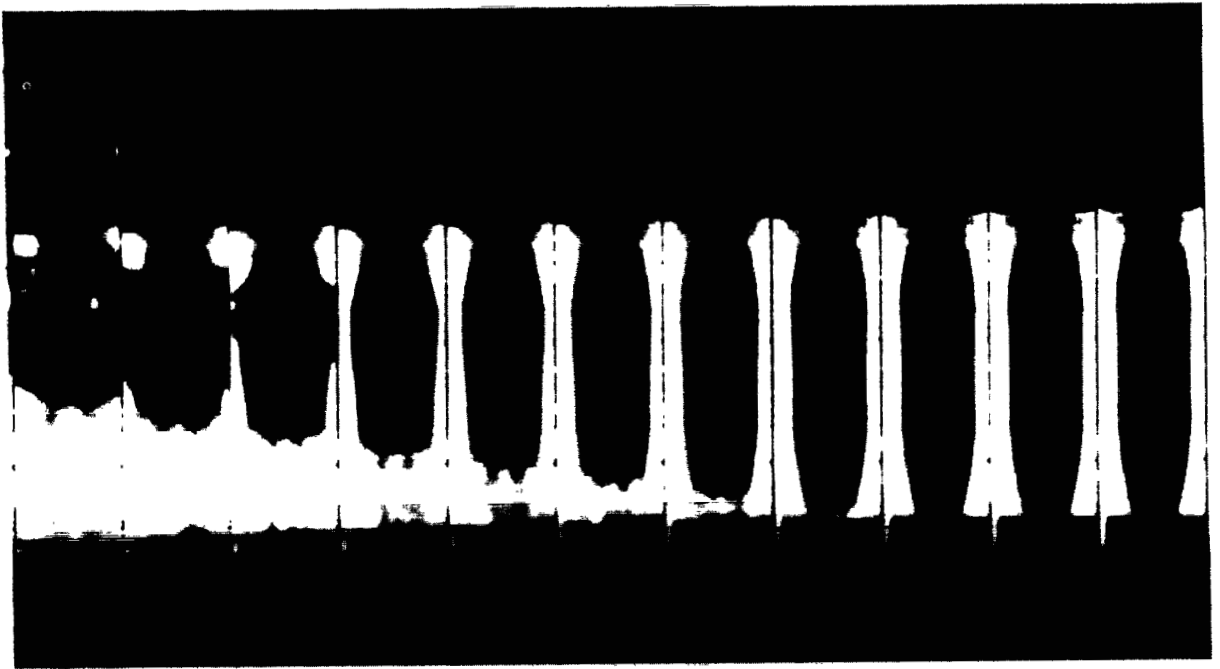

FIGURE 3

Section of high speed camera record showing the deflagration of an unplugged 105 mm HE shell

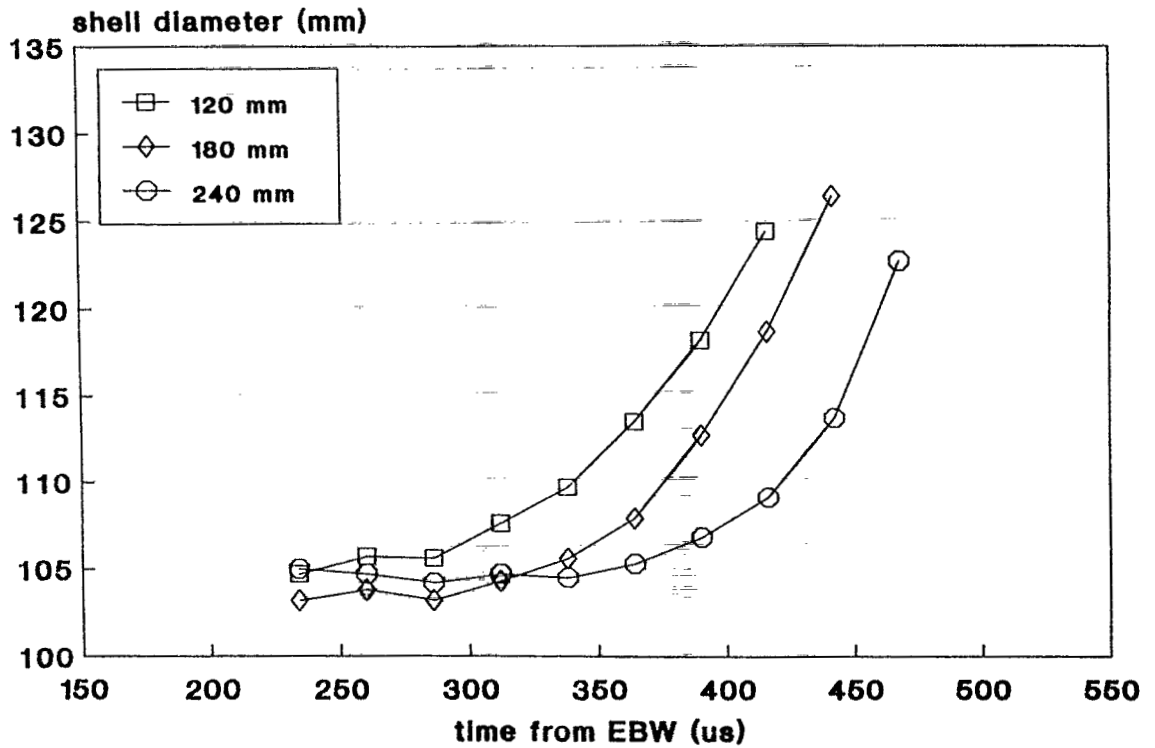

FIGURE 4

Plots of the expansion of a deflagrating 105 mm shell case

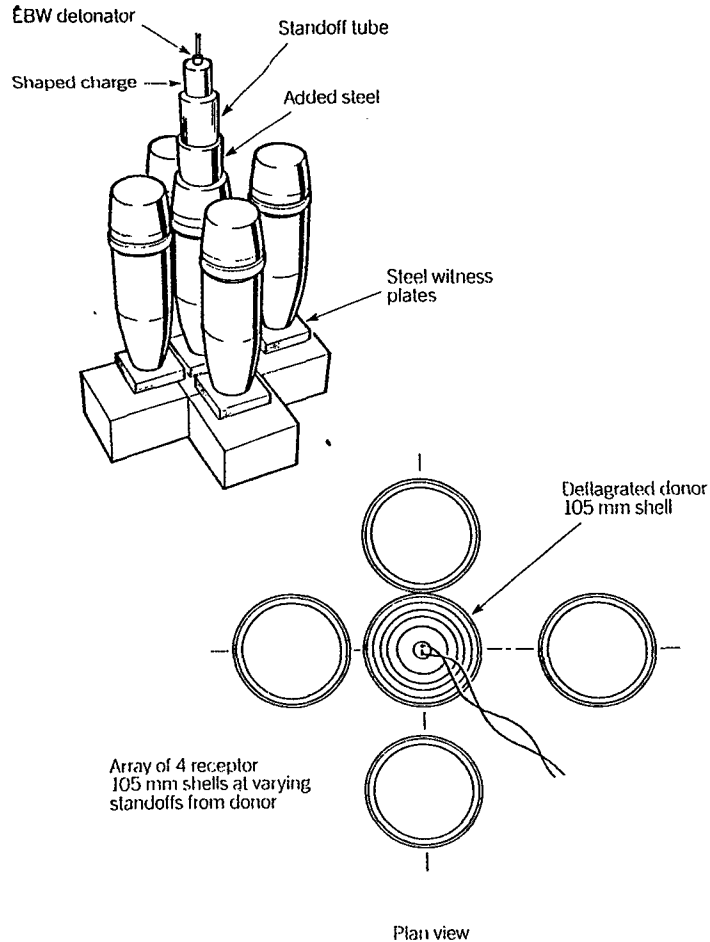

FIGURE 5  
Set-up for deflagration donor - multiple receptor tests

TABLE 1  
Characteristics of the controlled deflagration of  
Composition B filled 105 mm shell  
(Pt represents points as defined in the text, Section 2.2)

Shell Configuration	Time from the Detonator Pulse to Event			Deflagration Propagation Velocity		Maximum Expansion Velocity km/s	Estimated Initial Fragment Velocity km/s
	Initial Case Fracture $\mu$ s	Products from Nose $\mu$ s	Image Obscured $\mu$ s	From Case Expansion Data km/s	Calculated km/s		
Unplugged SHOT 1	440	310	490	2.3	2.5	*Pt 1, 0.24 Pt 2, 0.30 Pt 3, 0.35	Pt 1, 0.12 Pt 2, 0.15 Pt 3, 0.17
Unplugged SHOT 2	460	460	530	2.5	2.5	Pt 1, 0.22 Pt 2, 0.36 Pt 3, 0.22	Pt 1, 0.12 Pt 2, 0.18 Pt 3, 0.11
Plugged SHOT 3	340	470	440	-	2.5	Pt 1, 0.12 Pt 2, 0.08  Pt 3, 0.20	Obscured by Products  0.1
Plugged SHOT 4	320	450	370	-	2.5	Obscured by products	

fragment strikes on the central region of receptor shell where the case is at its thinnest (10 mm), further donor-receptor standoff tests were conducted using 105 mm shell. The experimental assembly is shown in Figure 5. Two experiments were undertaken with donors plugged with a PRF. Donor heights were adjusted to maximise fragment impacts on the central region of the receptor cases. In one test the 3 receptor rounds were placed at 1 charge diameter (105 mm) standoff from the donor and in the other the standoff distances were  $\frac{1}{2}$ , 1 and 2 charge diameters. Soft recovery of projected shell was provided by sand bag walls 1 m from ground zero.

In both tests the receptors were recovered intact but with flattened faces. Some exhibited imprints of fragment strikes along the central region of the case; the largest imprint being about 160 mm by 20mm by 1 mm deep. Two repeat shots were undertaken using the recovered receptors with the flattened faces away from the donor. In one test the 3 receptors were placed at  $\frac{1}{2}$  charge diameter standoff and in the other they were placed at 1 charge diameter standoff. The receptors were again recovered intact but exhibiting two flattened faces and further imprints from fragment strikes.

Reference to Table 1 shows that both plugged and unplugged 105 mm shell produced fragment velocities in the range 100 to 180 m/s, although the limited data for the plugged rounds should be treated with caution. These velocities are considerably lower than the critical impact velocity for the detonation threshold of several hundred meters per second for Composition B receptors with a 10 mm steel cover [9]. Also the fragment velocities for detonating Composition B loaded 105 mm shell are about 1.1 km/s [10] and these have produced receptor detonations in other tests in our study using the set-up shown in Figure 5. However it should be noted that in many of our tests the shell filling was damaged and exhibited increased sensitivity compared to a normal round [5]. A further feature of these tests is that the shell/target impacts represent fragment sizes beyond those reported in Reference 9.

The effect of heavy side confinement produced by a munition stack surrounding a single deflagrating 105 mm shell was investigated. This was undertaken by placing a shell as a push fit into a 15 mm thick, steel walled tube that covered the length of the munitions. The assembly was designed to prevent the deflagration process from producing an early break in confinement by restricting the initial stages of case expansion. We consider this test represents an extreme example of side confinement. The round was deflagrated in the normal manner. The steel tube was split open and recovered within 1 m of the firing position. Shell case fragments were recovered inside and around the steel tube and they were typical of a deflagrating munition. Therefore we conclude that a deflagration to detonation transition did not occur.

Thus neither the experiments investigated in this study or those previously reported with Composition B loaded 105 mm HE shell produced results to support a process by which a violently deflagrating donor may produce a mass detonation. This was despite some evidence that nose plugs may produce a confinement effect that influences case expansion.

### **3.2 81 mm Mortar**

The 81 mm mortar was selected to investigate the propensity for deflagrating thin cased munitions to produce mass detonation in neighbouring rounds. The mortar is filled with Composition B and the thickness of the case around the central region is 5 mm.

One series of tests was conducted using a set-up similar to that shown in Figure 5 except that the deflagrating central donor and the receptors were 81 mm mortar. Experiments were conducted with the receptors at 0,  $\frac{1}{2}$ ,  $\frac{3}{4}$  and 1 charge diameter standoff. Like the 105 mm shell firings, tests were undertaken without booster and fuzes, with pressed TNT flake boosters and PRF's and with recovered damaged rounds. In two tests the donor height was adjusted in order to allow fragment strikes at the central region of the receptors. All donors deflagrated as planned. Recovered receptors had flattened faces and damaged fillings but the cases were intact; some had markings from fragment strikes. Recovered receptors from repeated firings had 2 flat faces.

In another series of tests the deflagrating donor was used to project an adjacent round to impact a concrete wall or steel plate. Firings were conducted with mortars without boosters and fuzes, with boosters and PRF's and recovered damaged rounds. The projection velocity of the receptor was determined using high speed photography to be 30 m/s. In these tests the explosive filling will have been damaged (sensitised) prior to impact on the hard surface by the projection process.

All donors deflagrated as planned and the recovered projected rounds had flattened faces, damaged fillings but the cases were intact.

These experiments suggest that for simple arrays a violently deflagrating 81 mm mortar is unlikely to be the direct cause of a mass detonation by the effects of fragmentation/blast on near neighbours or by the projection and impact on adjacent rounds.

### **3.3 105 mm Shell and 81 mm Mortar Mixed Arrays**

Experiments with mixed munition arrays with 105 mm shell as the deflagrating donor and 81 mm mortar as the receptors were undertaken to assess the effects of large, thick fragments on thin cased damaged fillings. In this context the 105 mm shell has a significantly larger explosive mass than the 81 mm mortar (3.5 kg compared to 1.0 kg) and the central region case thicknesses are 10 mm and 5 mm

respectively. The test array set-up was similar to that shown in Figure 5. The damaged mortar rounds were recovered from other tests; therefore their fillings would be more sensitive than unused rounds and thus have a lower detonation threshold to fragment impact.

In two tests undertaken with a plugged 105 mm shell as donor, the 81 mm mortar receptors detonated and witness block marks indicated the donor deflagrated as planned. For the third experiment which had an unplugged 105 mm shell as donor, the 81 mm receptors did not detonate but were split open with the filling dispersed. It is not possible to draw any firm conclusions from these few tests but the results suggest further study with the conditions that may be expected to maximise the mass detonation hazard from deflagrating rounds.

#### **4.0 CONCLUSIONS**

The characteristics of Composition B loaded 105 mm shell and 81 mm mortar deflagrating at a rate of about 2.5 km/s have been determined. Some of these characteristics are important in assessing the role of violently deflagrating rounds in mass detonation. There is some evidence to suggest that nose plugs may confine the deflagration process and affect the onset of case breakup. Violently deflagrating 105 mm shell and 81 mm mortar did not cause detonation of neighbouring munitions in tests with multiple acceptors and projected acceptors impacting on hard surfaces. These tests used receptors with and without boosters and nose plugs; repeat shots used recovered damaged receptors.

Preliminary results using deflagrating, plugged 105 mm shell donors that detonated damaged 81 mm mortars suggest further study into the conditions that may be expected to maximise the mass detonation hazard from violently deflagrating munitions.

#### **5.0 ACKNOWLEDGMENTS**

We express our gratitude to the Officer Commanding and support personnel of the Army Proof and Experimental Establishment, Graytown, Victoria for assistance with the field firings and ensuring the ready availability of support resources.

#### **6.0 REFERENCES**

1. Frey R.B., Watson J., Gibbons G., Boyle V. and Lyman D. Proceedings of the Joint Government Industry Symposium on Insensitive Munitions Technology, NSW, White Oak, Maryland, US, March 1990.
2. Stosz M. TTCP WAG-11 Workshop, Quebec, Canada, 1987.

3. Frey R.B. and Trimble J.J. Proceedings Seventh International Symposium on Detonation, NSWC, MP82-334, 1981.
4. Chick M. and Bussell T.J. Paper in course of publication.
5. Chick M., Bussell T.J. and McVay L. Proceedings of 24th DOD Explosives Safety Seminar, St. Louis, Missouri, USA, August 1990.
6. Kinsey T.J., Bussell T.J. and Chick M. MRL Technical Report MRL-TR-91-42, 1992.
7. Chick M., Bussell T.J., Frey R.B. and Bines A. Proceedings of Ninth Symposium (International) on Detonation, Portland, Oregon, USA, 1989.
8. Chick M. and Hatt D.J. Proceedings of the Seventh Symposium (International) on Detonation, NSWC MP82-334, 1981.
9. Howe P., Watson J.L. and Frey R.B. Proceedings of Seventh Symposium (International) on Detonation, NSWC, MP82-334, 1981.
10. Jenks G.J., Lynch B.J., Masinskas J.J. and Oliver D.J. DSL Report 489, 1972, Confidential.