

U. S. AIR FORCE
INSENSITIVE MUNITIONS PROGRAM

by
Joseph Jenus, Jr.

Report Documentation Page

*Form Approved
OMB No. 0704-0188*

Public reporting burden for the collection of information is estimated to average 1 hour per response, including the time for reviewing instructions, searching existing data sources, gathering and maintaining the data needed, and completing and reviewing the collection of information. Send comments regarding this burden estimate or any other aspect of this collection of information, including suggestions for reducing this burden, to Washington Headquarters Services, Directorate for Information Operations and Reports, 1215 Jefferson Davis Highway, Suite 1204, Arlington VA 22202-4302. Respondents should be aware that notwithstanding any other provision of law, no person shall be subject to a penalty for failing to comply with a collection of information if it does not display a currently valid OMB control number.

1. REPORT DATE AUG 1990	2. REPORT TYPE	3. DATES COVERED 00-00-1990 to 00-00-1990			
4. TITLE AND SUBTITLE U.S. Air Force Insensitive Munitions Program		5a. CONTRACT NUMBER			
		5b. GRANT NUMBER			
		5c. PROGRAM ELEMENT NUMBER			
6. AUTHOR(S)		5d. PROJECT NUMBER			
		5e. TASK NUMBER			
		5f. WORK UNIT NUMBER			
7. PERFORMING ORGANIZATION NAME(S) AND ADDRESS(ES) DOD Explosives Safety Board, ,Alexandria,VA,22331		8. PERFORMING ORGANIZATION REPORT NUMBER			
9. SPONSORING/MONITORING AGENCY NAME(S) AND ADDRESS(ES)		10. SPONSOR/MONITOR'S ACRONYM(S)			
		11. SPONSOR/MONITOR'S REPORT NUMBER(S)			
12. DISTRIBUTION/AVAILABILITY STATEMENT Approved for public release; distribution unlimited					
13. SUPPLEMENTARY NOTES See also ADA235005, Volume 1. Minutes of the Explosives Safety Seminar (24th) Held in St. Louis, MO on 28-30 August 1990.					
14. ABSTRACT					
15. SUBJECT TERMS					
16. SECURITY CLASSIFICATION OF:			17. LIMITATION OF ABSTRACT Same as Report (SAR)	18. NUMBER OF PAGES 21	19a. NAME OF RESPONSIBLE PERSON
a. REPORT unclassified	b. ABSTRACT unclassified	c. THIS PAGE unclassified			



POLICY

NEAR TERM

REDUCE HAZARDS PRESENTED BY INVENTORY MUNITIONS BY DEVELOPING AND INCORPORATING ENERGY SUPPRESSION DEVICES, PACKAGING REDESIGN, APPLYING INNOVATIVE STORAGE AND HANDLING TECHNIQUES, AND UTILIZATION OF STORAGE FACILITIES

LONG RANGE

TRANSITION TO INSENSITIVE OR LESS SENSITIVE MUNITIONS IN ALL MAJOR WEAPONS SYSTEMS AS SOON AS PRACTICAL WITHOUT LOSING OPERATIONAL EFFECTIVENESS / CAPABILITY



WHAT THE IM PROGRAM DOES

- **PROVIDE A MORE EFFICIENT AND EFFECTIVE AIR FORCE**
 - ELEVATE MOBS AND COBS TO FULL CAPABILITY
 - MUNITIONS ON BASE
 - NEAR HARDENED A/C SHELTERS
 - INCREASE SURVIVABILITY OF AIRBASE AND ASSETS
 - MINIMIZE MAXIMUM CREDIBLE EXPLOSIVES EVENT
 - FREE UP TRANSPORTATION RESOURCES

- **SAVE MONEY**
 - COST AVOIDANCE
 - REDUCE COSTS



SUPPORT

- HQ TAC / LG message to HQ USAF / XOO / LEY / AQT, Mar 89 --- "...IM Program believed to have significant impact on effort to maintain current levels of operational support..." "Tac will submit IM as separate candidate for the FY 91 TAF RD&A list."
- AFISC / CC message to HQ USAF / XOO / LEY, May 90 --- "...IM Program has great potential benefit by providing operational capability within existing safety constraints and in permitting the use of new safety criteria which more accurately reflect the actual risk posed by munitions and explosives."
- SAC / CS letter to HQ USAF / LEY / LEE / XOX, December 89 --- "...IM program will benefit the Strategic Air Command by enhancing personnel and ordnance safety and increasing our munitions storage capability without increasing construction costs..."
- HQ PACAF / DO / LG message to HQ USAF / XOO / AQT / LEY, May 90 --- "...this command strongly supports the benefits of the insensitive munitions (IM) program offers. We believe it offers great potential, decreases cost and increases our command's combat capability."
- HQ USAF / XOX message to MSD / CC, April 90 --- "...expect IM will offer high payoff in terms of reduced munitions malpositioning problems, increase air base survivability, safer and less costly transportation and storage."
- HQ USAFE / LGW / DEV / SEW message to HQ USAF / LEY, October 89 --- "...capability to store munitions is presently restricted by inaccurate, inflated, or undetermined explosive criteria. IM program provides a near-term avenue for resolving these problems. Request immediate support..."



PROGRAM ACTIVITIES / STATUS

HQ / TAC BRIEFED 8 JUNE 90

- **DR DRAFTING PDP FOR SUBMISSION IN TAC'S FY91 RD & A LIST**
- **DR NOTIFIED AIR STAFF OF THEIR INTENT**
- **DR MESSAGE 26 JULY 90 TO ALL MAJCOMS REQUESTING THEY INCLUDE THE IM PROGRAM ON THEIR FY91 RD & A LIST**

HQ USAF / XOO / LEY / LEX BRIEFED 3 JULY 90

- **REACTION - FULL SUPPORT**
- **XOO BRIEFING DO LOGISTIC COMMANDERS**
- **ACTIONS TAKEN TO IDENTIFY POTENTIAL FUNDING SOURCES**



BACKGROUND

- SEPT 87 INSENSITIVE MUNITIONS MOU SIGNED BY JCS
- SEPT 87 CSAF/CV DIRECTED THE DEVELOPMENT AND IMPLEMENTATION OF AN IM PROGRAM
- SEPT 87 IM PROGRAM OFFICE CADRE FORMED
- MAR 88 AFSC SUBMITTED DRAFT MASTER PLAN TO CSAF/CV
- APR 89 MASTER PLAN APPROVED BY HQ USAF/XOX
- MAY 89 TAF SON 309-88 VALIDATED
- JAN 90 PMD BEING STAFFED AT AIR STAFF



HOW IM WILL BE ACCOMPLISHED

- **PROVIDE SITE SURVEY / MUNITIONS HAZARD REDUCTION PLANNING**
- **DEVELOP / IMPLEMENT PROGRAMS TO MITIGATE REACTIONS BETWEEN MUNITIONS**



CROTONE AIR BASE SURVEY

- USAFE / DEE REQUESTED A REVIEW OF A&E'S 35% DESIGN OF CROTONE AB EXPLOSIVES FACILITIES
- FACILITIES RE-SITED TO ELIMINATE DISCREPANCIES, REDUCE COST AND IMPROVE EFFICIENCY

A&E DESIGN

- 55 IGLOOS (31 RESTRICTED)
- 34 NATO SURVIVABILITY CRITERIA VIOLATIONS
- MUNITIONS OPERATING FACILITIES RESTRICTED

DESIGN RECOMMENDED BY SURVEY (SAME LAND AREA)

- 60 IGLOOS (NONE RESTRICTED)
24 ADDITIONAL (FUTURE EXPANSION)
- NO SURVIVABILITY VIOLATIONS
- NO RESTRICTIONS



OMAN SITE PLANNING

- **IN SUPPORT OF CENTAF / LGW**
- **REVISED SITINGS OF THREE AIR BASES IN OMAN**
- **SIGNIFICANT INCREASE IN NET EXPLOSIVES WEIGHT (NEW)**
 - **4.6 MILLION POUNDS NEW WITH NO CONSTRUCTION**
 - **ADDITIONAL 1.7 MILLION POUNDS BY CONSTRUCTING EARTH BARRICADES**
- **ALL GAINS MADE WITHIN EXISTING CLEAR ZONES**



IM DEVELOPMENT PROGRAM / TEST TASKS

- ⊙ MUNITIONS STORAGE MODULE(S)
 - HARDENED AIRCRAFT SHELTER
 - GENERIC BUFFER FOR STORAGE
 - 1.2 HAZARD REDUCTION
- ⊙ FLIGHTLINE STORAGE BINS
 - LIGHTNING PROTECTION
 - CBU 87 / 89
 - AIM-7 / AIM-9 HAZARD REDUCTION
- ⊙ 40MM GRENADE (M433)
 - AGM 65 PROPAGATION TEST
 - AGM 65 MOTOR CONTRIBUTION TEST
 - AGM 45 HAZARD CLASSIFICATION TEST
 - MK 20 HAZARD REDUCTION
 - STANDARDIZED BUILD-UP AREA



MUNITIONS STORAGE MODULE (MSM)

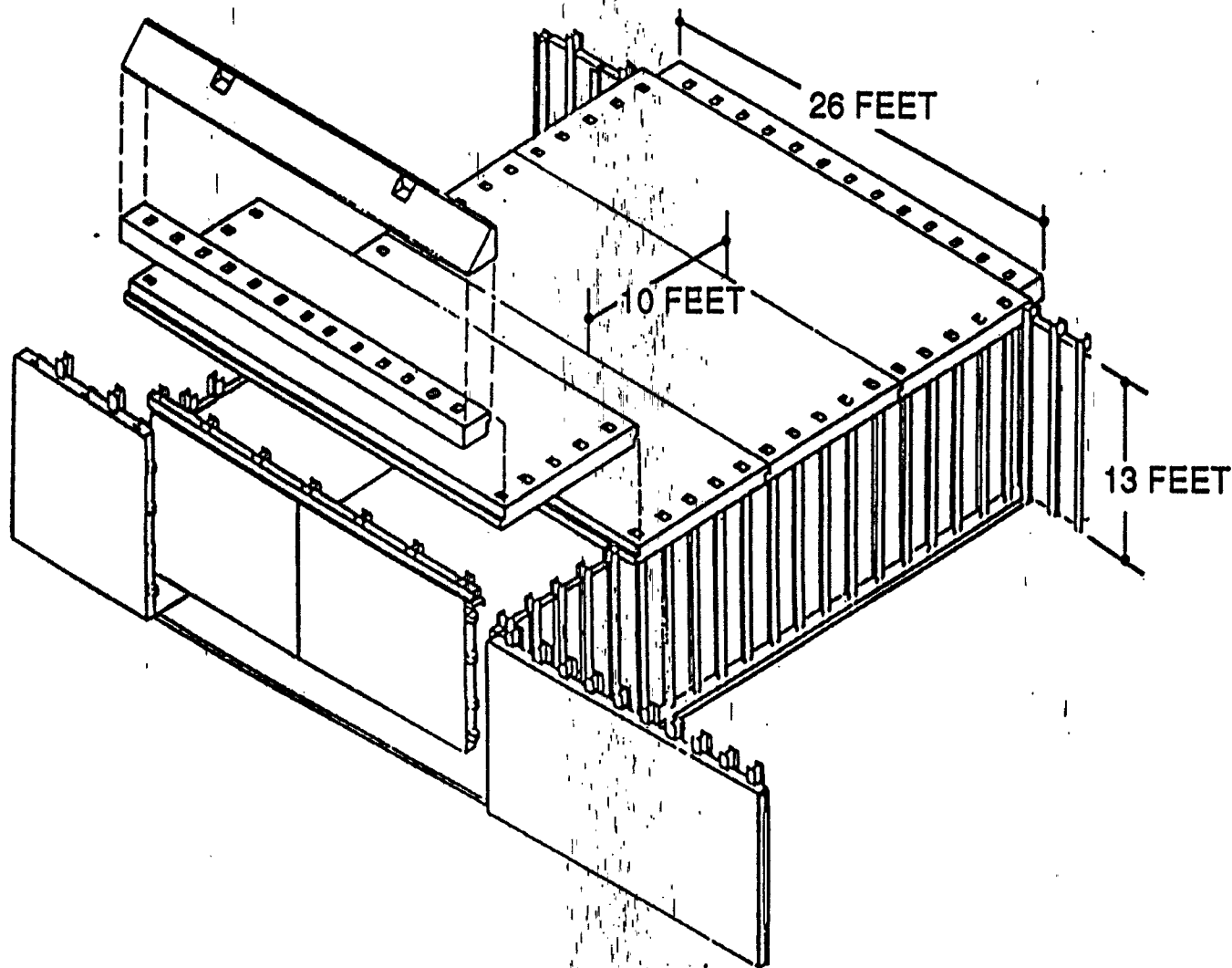



CONVENTIONAL SITING

84 STRUCTURES
9.9 M POUNDS NEW
\$ 37.8M STD IGLOO
\$ 21.0M MSM

CLEAR ZONE

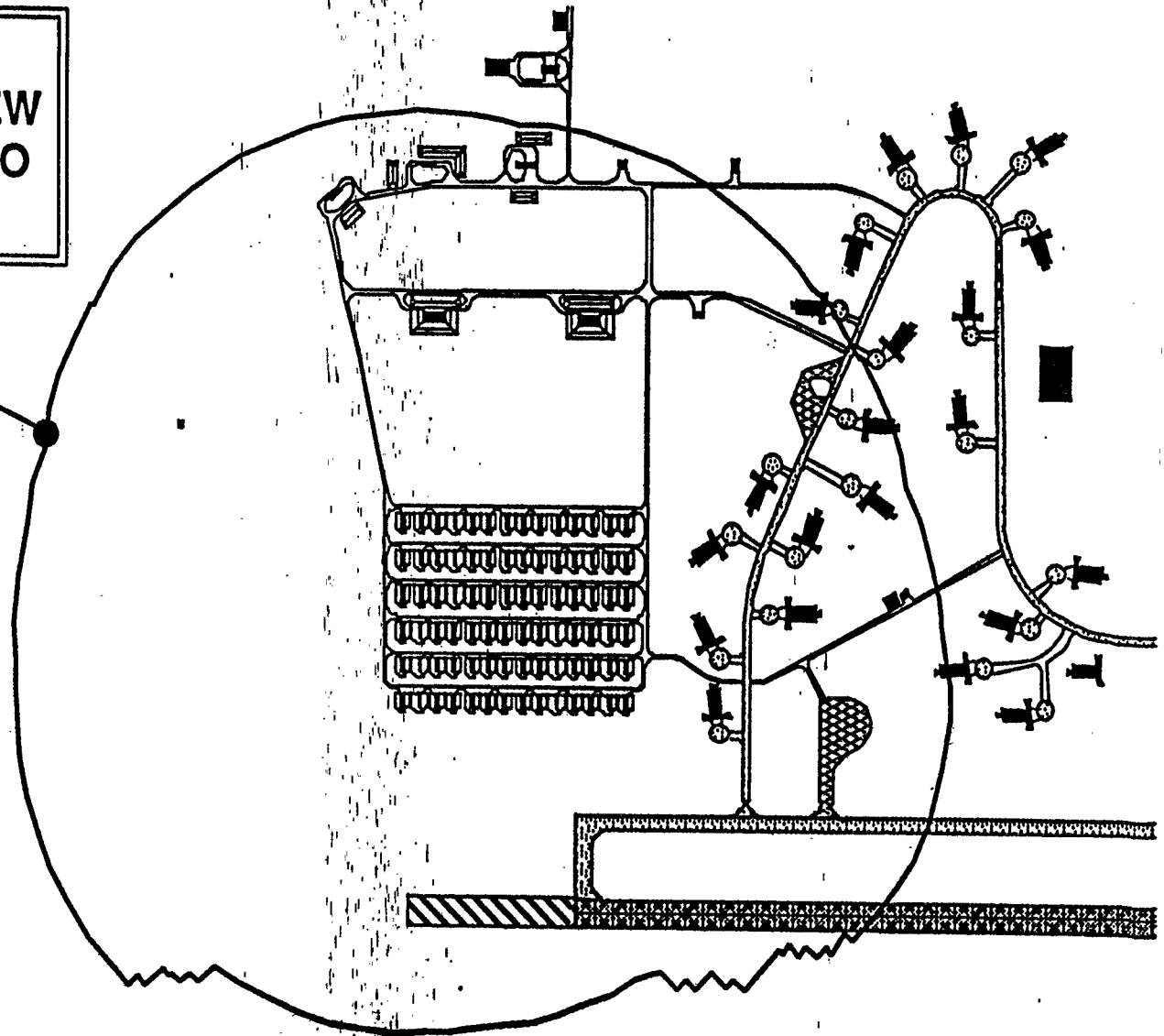



MUNITIONS STORAGE MODULES SAME FOOTPRINT

165 20 FOOT MSM
COST \$ 16.5M
9.9 M POUNDS NEW

ORIGINAL
CLEAR ZONE

NEW
CLEAR ZONE

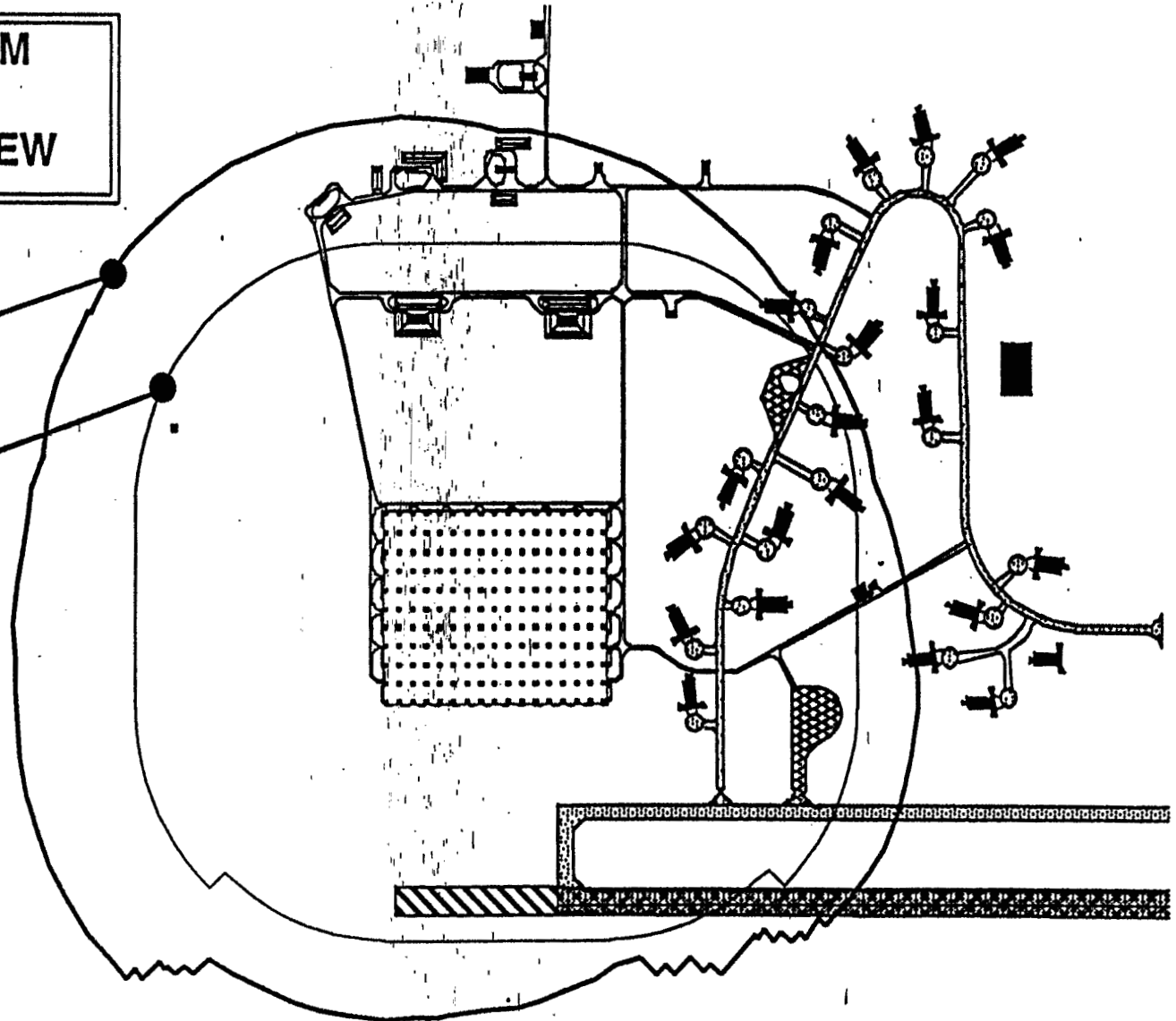



MSM PAYOFF

- OPERATIONAL
 - MORE MUNITIONS ON BASE
 - INCREASED SURVIVABILITY
 - SITE ADAPTABLE
- COST
 - STANDARD 80 FOOT IGLOO \approx \$450K
 - 80 FOOT MSM \approx \$250K
- COST SAVINGS (POTENTIAL)
 - GREATER THAN \$ 20 M PER YEAR OVER NEXT SEVEN YEARS
- STATUS
 - \$950K REQUIRED TO COMPLETE
 - SCHEDULE - ONE YEAR



40 MM GRENADE (M433)

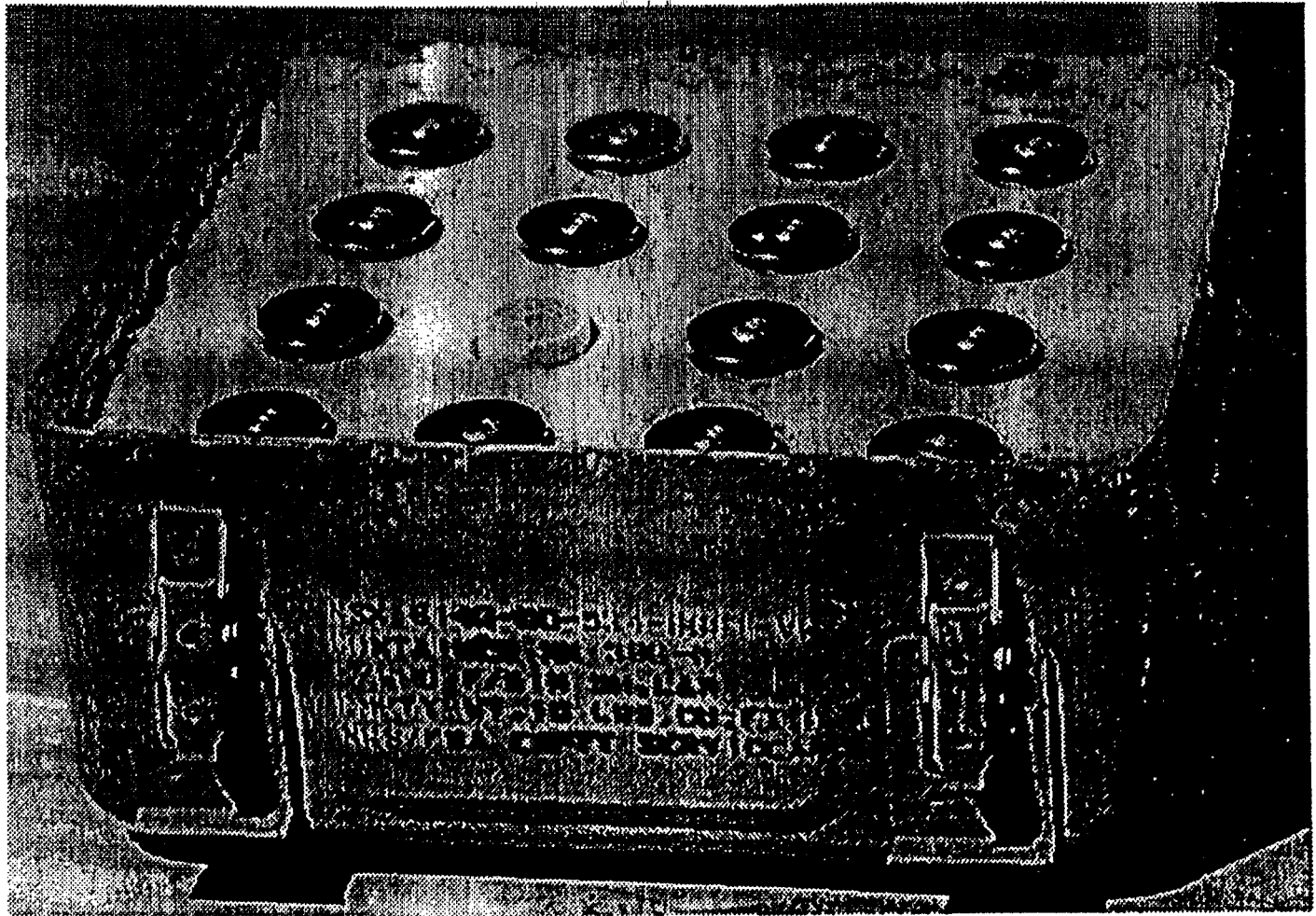



40MM GRENADE PAYOFF

- **GRENADES IN ARMORY WHERE NEEDED**
- **MASS DETONATION HAZARD ELIMINATED**
- **STATUS**
 - **FEASIBILITY DEMONSTRATED**
 - **\$200K REQUIRED TO COMPLETE**
 - **SCHEDULE - ONE YEAR**



FLIGHTLINE STORAGE BINS

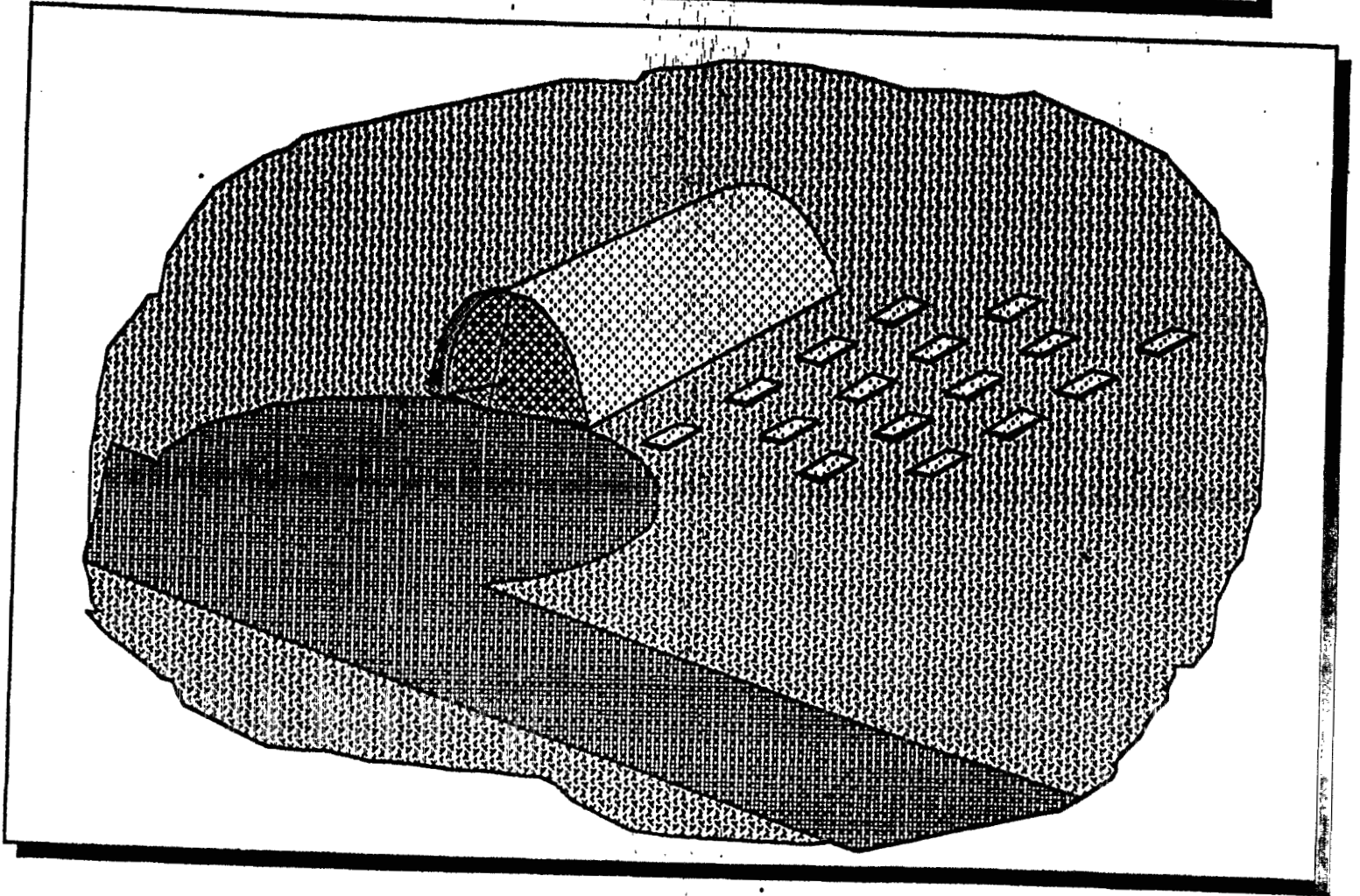



FLIGHTLINE STORAGE BINS

32 SORTIES OF MUNITIONS
ADJACENT TO EACH HAS

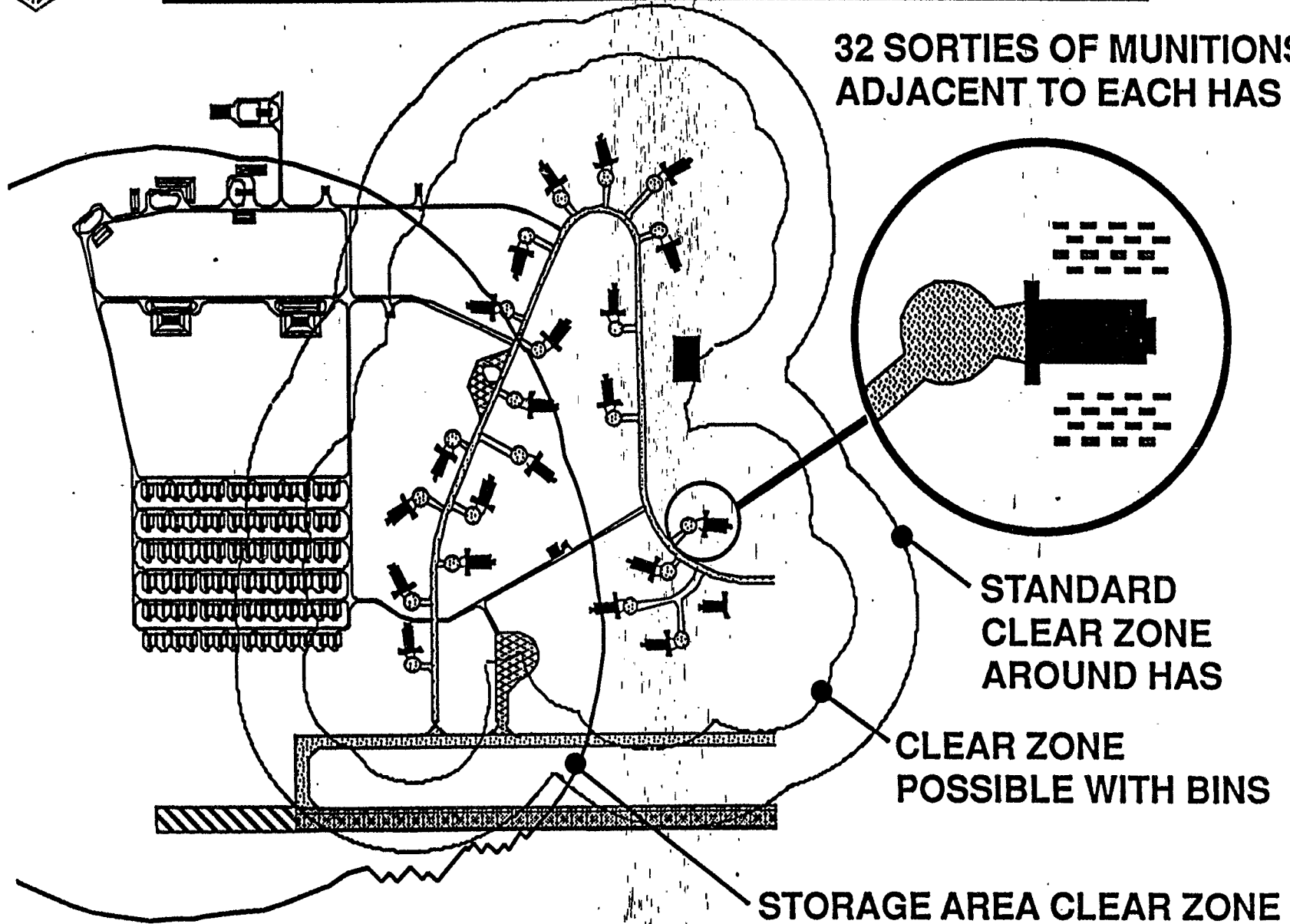



FLIGHTLINE STORAGE BIN PAYOFF

- **OPERATIONAL**
 - **MUNITIONS AT HAS-WHERE NEEDED WHEN NEEDED**
 - **INCREASED SORTIE GENERATION CAPABILITY**
 - **INCREASED WARFIGHTING CAPABILITY**
 - **INCREASED SURVIVABILITY**

- **COST**
 - **COULD REDUCE IGLOO REQUIREMENTS**

- **STATUS**
 - **FEASIBILITY DEMONSTRATED**
 - **\$ 1.5 M REQUIRED TO COMPLETE**
 - **SCHEDULE - TWO YEARS**



AF IM REQUIRED FUNDING PROFILE (DOLLARS IN THOUSANDS)

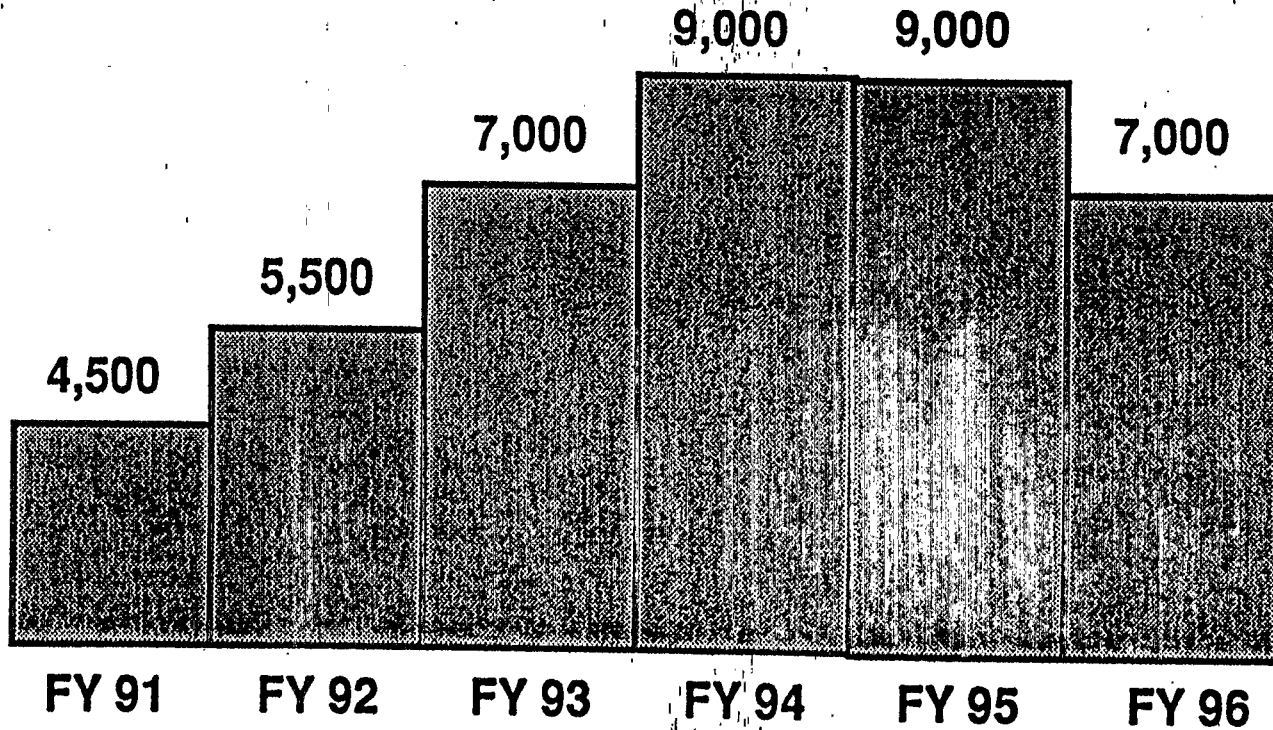



SUMMARY

- IM PROGRAM WILL IMPROVE OPERABILITY AND SURVIVABILITY
- SIGNIFICANT COST AVOIDANCE / COST SAVINGS
- AFSC POSTURED TO EXECUTE THE IM PROGRAM
 - BASIC PROGRAM OFFICE ESTABLISHED
 - IM EFFORTS ORGANIZED AND CENTRALIZED
 - PROGRAM IMPLEMENTATION APPROACH IDENTIFIED