



SYSTEMS
Development &
Maturity Laboratory

System Capability Satisficing in Defense Acquisition via Component Importance Measures

Dr. Brian Sauser

Dr. Jose Ramirez-Marquez

Weiping Tan, Romulo Magnaye

Dr. David Nowicki and Dr. Abhijit Deshmukh

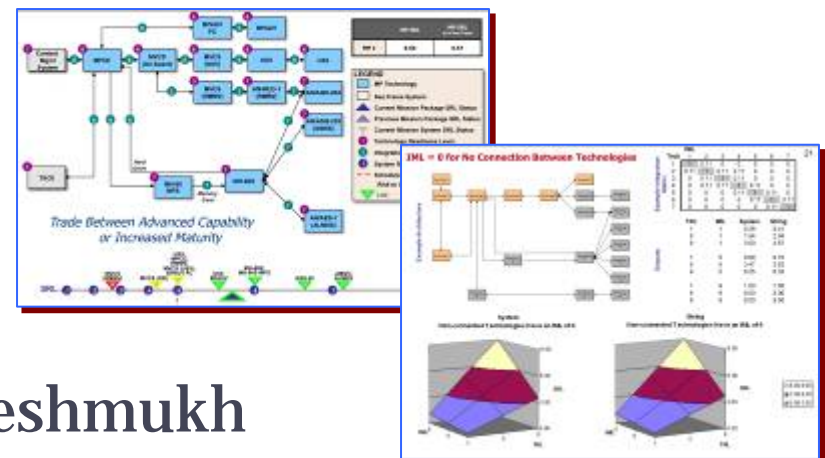

Report Documentation Page

Form Approved
OMB No. 0704-0188

Public reporting burden for the collection of information is estimated to average 1 hour per response, including the time for reviewing instructions, searching existing data sources, gathering and maintaining the data needed, and completing and reviewing the collection of information. Send comments regarding this burden estimate or any other aspect of this collection of information, including suggestions for reducing this burden, to Washington Headquarters Services, Directorate for Information Operations and Reports, 1215 Jefferson Davis Highway, Suite 1204, Arlington VA 22202-4302. Respondents should be aware that notwithstanding any other provision of law, no person shall be subject to a penalty for failing to comply with a collection of information if it does not display a currently valid OMB control number.

1. REPORT DATE MAY 2010		2. REPORT TYPE		3. DATES COVERED 00-00-2010 to 00-00-2010	
4. TITLE AND SUBTITLE System Capability Satisficing in Defense Acquisition via Component Importance Measures				5a. CONTRACT NUMBER	
				5b. GRANT NUMBER	
				5c. PROGRAM ELEMENT NUMBER	
6. AUTHOR(S)				5d. PROJECT NUMBER	
				5e. TASK NUMBER	
				5f. WORK UNIT NUMBER	
7. PERFORMING ORGANIZATION NAME(S) AND ADDRESS(ES) Stevens Institute of Technology, Castle Point on Hudson, Hoboken, NJ, 07030-5991				8. PERFORMING ORGANIZATION REPORT NUMBER	
9. SPONSORING/MONITORING AGENCY NAME(S) AND ADDRESS(ES)				10. SPONSOR/MONITOR'S ACRONYM(S)	
				11. SPONSOR/MONITOR'S REPORT NUMBER(S)	
12. DISTRIBUTION/AVAILABILITY STATEMENT Approved for public release; distribution unlimited					
13. SUPPLEMENTARY NOTES 7th Annual Acquisition Research Symposium to be held May 12-13, 2010 in Monterey, California. U.S. Government or Federal Rights License					
14. ABSTRACT					
15. SUBJECT TERMS					
16. SECURITY CLASSIFICATION OF:			17. LIMITATION OF ABSTRACT	18. NUMBER OF PAGES	19a. NAME OF RESPONSIBLE PERSON
a. REPORT unclassified	b. ABSTRACT unclassified	c. THIS PAGE unclassified			

With ever-increasing environmental and technical complexities, three challenges persist and continue to propagate...

- **Lifecycles:** System's lifecycles from conception to sustainment are comprised of interrelated clockspeeds linked by legacy, change, and unpredictable demand.
- **Decisions:** Our ability to understand, monitor, measure, and govern a system's lifecycle is not keeping pace with the rate of systems' change.
- **Solutions:** Our understanding of how systems can be integrated to provide a "good enough" solution to meet a capability in an agile environment is insufficient.

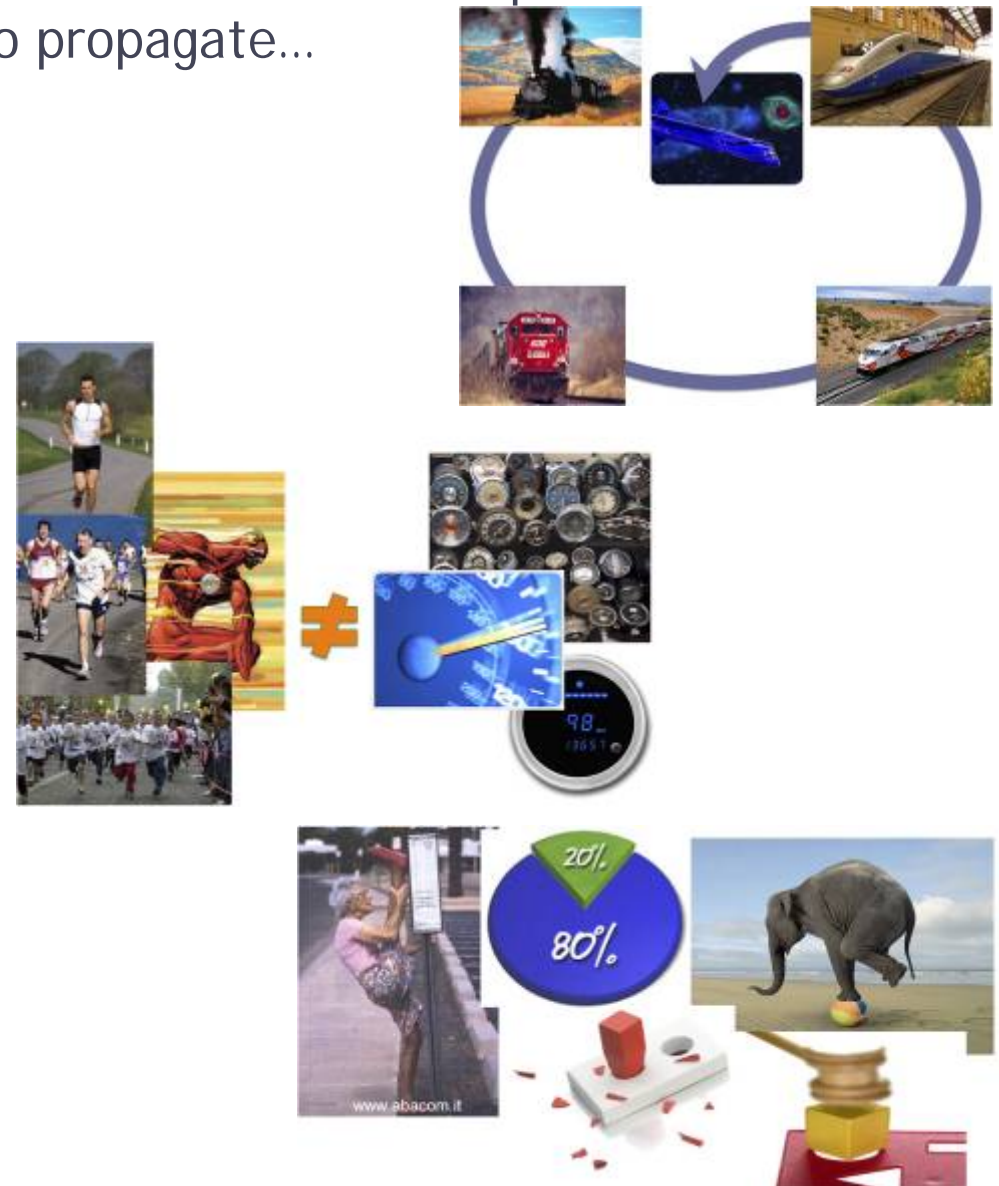

System Capability Satisficing

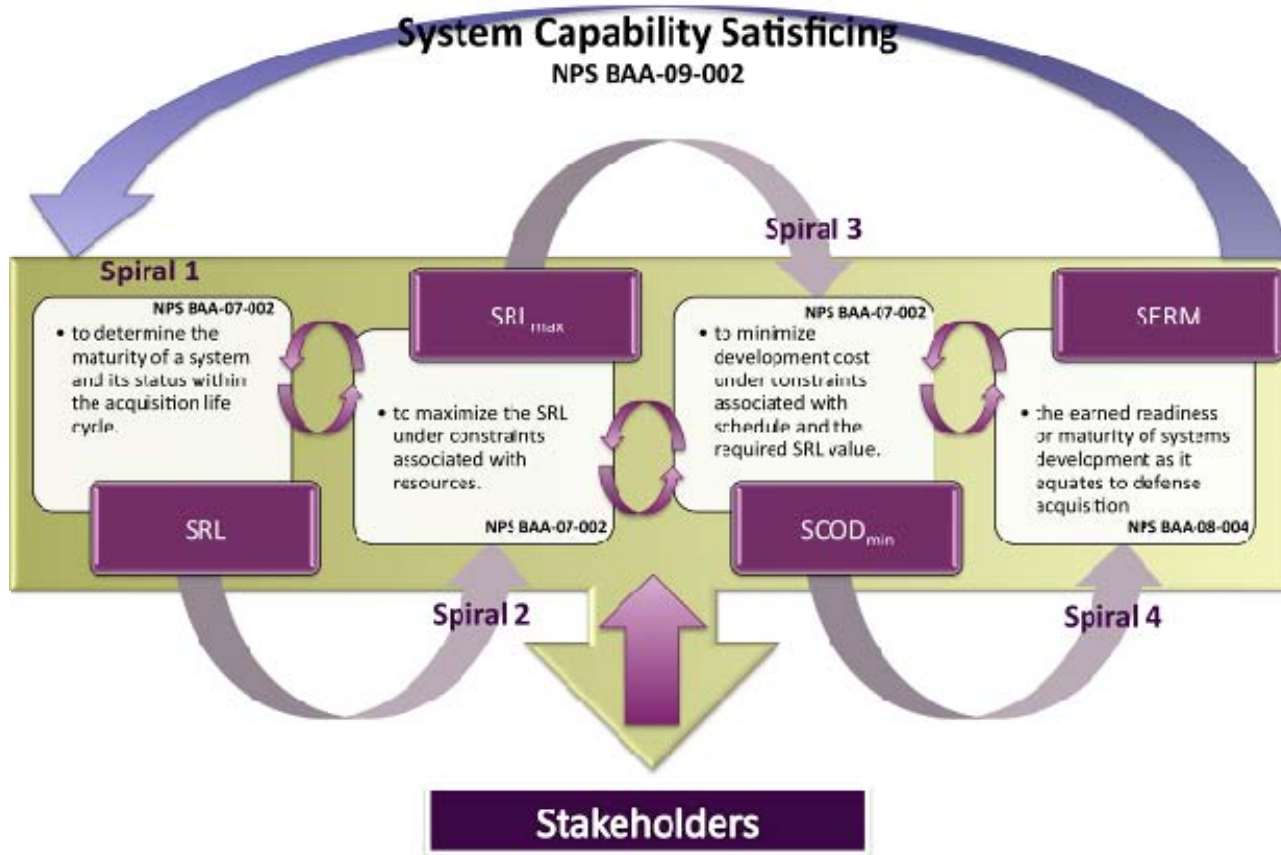

“What technologies and integrations are important or critical to each architectural view to achieve a functionality or capability?”

“What functionalities or capabilities are sufficient, critical, or important to achieving a level of system maturity that can satisfy a warfighter’s needs?”

“What impact does this have on system maturity and ultimately the acquisition of a deployable system?”

Key Performance Parameter

- **The U.S. government mandates that Key Performance Parameters (KPP) must be specified in the Capability Development Document (CDD) and Capability Production Document (CPD), and be verified by testing and evaluation or analysis.**
- **Key Performance Parameters (KPP) are “those attributes or characteristics of a system that are considered critical or essential to the development of an effective military capability and those attributes that make a significant contribution to the characteristics of the future joint force as defined in the Capstone Concept for Joint Operations (CCJO)” - DAU 2009**

- Volkert's methodology (2009) to predict the achieved capability of satisfying KPP

$$T = SRL * \alpha$$

- α : the maximum level of performance capability of satisfying a KPP.
- **SRL**: the proportional level of performance expected at a specific maturity stage.

$$SRL = f(TRL, IRL)$$

- **T**: the achieved performance level of the capability which satisfies the corresponding KPP.

- **Volkert's approach**

- **Can-do**

- Track the development progress with respect to achieved capability performance.
 - Identify development problems in terms of actual progress against that is planned.

- **Cannot-do**

- Prescribe resources allocation to fix development problems

Then...

- **Component importance analysis with measures**

Component Importance Measure 1 - System Capability Satisficing with Respect to TRL/IRL (IP)

The System

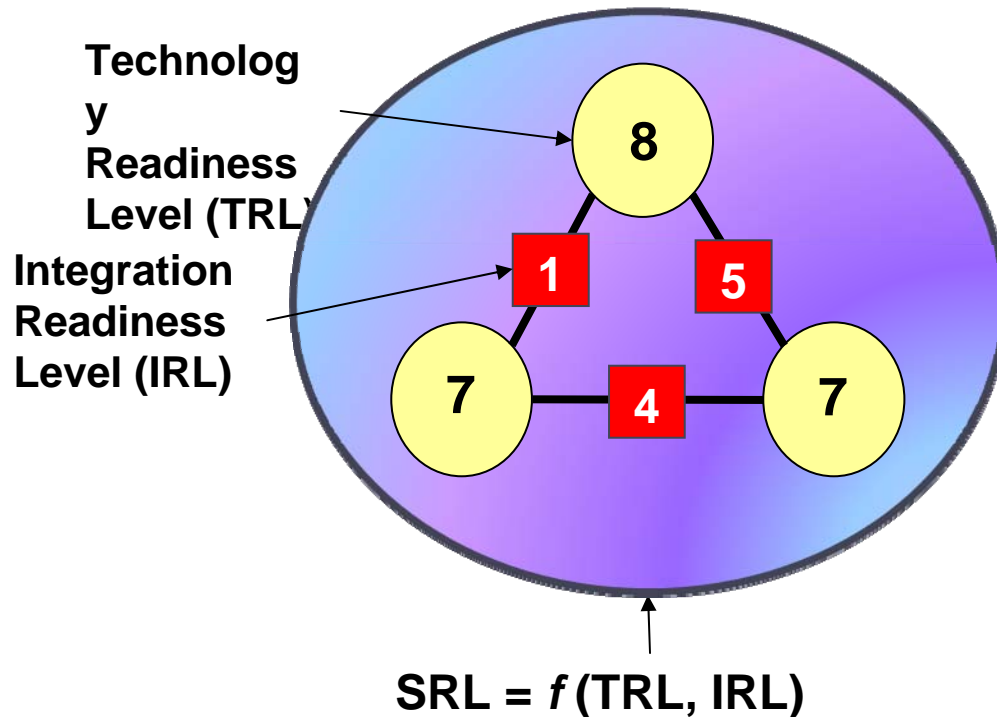

- What's the impact of component readiness level on SRL?
- Which component(s) should be improved to a target readiness level?

Component Importance Measure 1

- System capability satisficing with respect to **TRL/IRL (I^P)**

$$\text{For } TRL, I_i^P = \frac{SRL(TRL, IRL \mid TRL_i = \overline{TRL}_i)}{SRL(TRL, IRL)}$$

$$\text{For } IRL, I_{ij}^P = \frac{SRL(TRL, IRL \mid IRL_{ij} = \overline{IRL}_{ij})}{SRL(TRL, IRL)}$$

- $SRL(TRL, IRL)$: Current system SRL
- $SRL(TRL, IRL \mid TRL_i = \overline{TRL}_i)$: the resultant SRL when TRL_i changes to a target maturity level and all other $TRLs/IRLs$ stay on current maturity values (the same for IRL_{ij}).

Component Importance Measure 2 - System Capability Satisficing with Respect to **Cost** (I^{CT})

The System

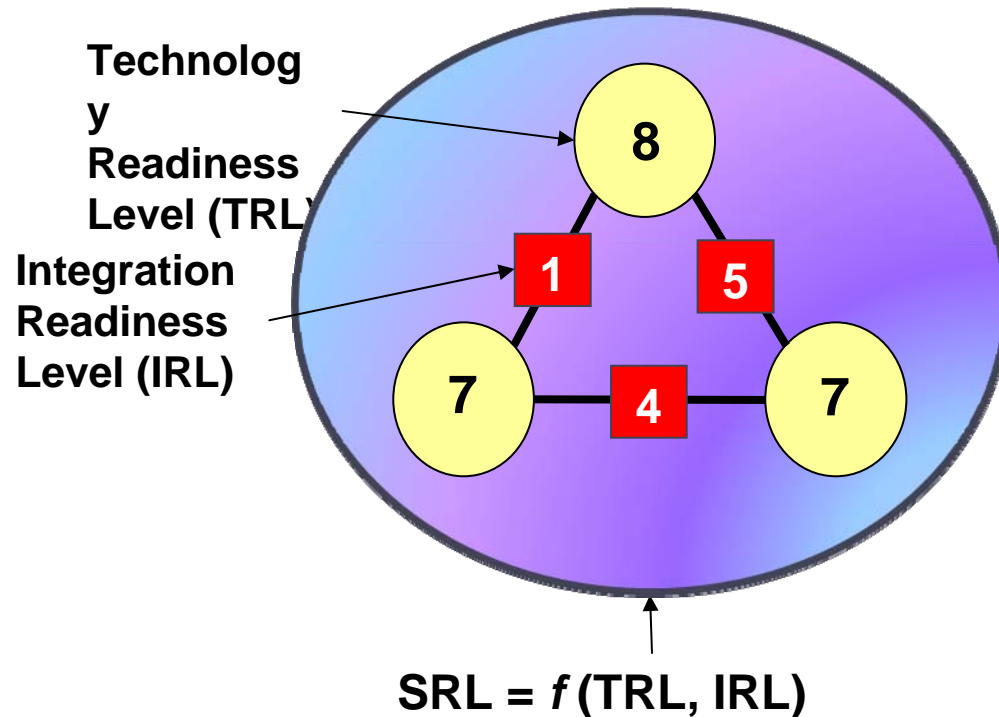

- Certain amount of



- Where to put the available **money** to achieve more system maturity?

Component Importance Measure 2

- System capability satisficing with respect to **cost** (ICT)

$$\text{For } TRL, I_i^{CT} = \frac{\Delta SRL}{CT_i} = \frac{SRL(TRL, IRL | TRL_i = \overline{TRL_i}) - SRL(TRL, IRL)}{CT_{\overline{TRL_i}} - CT_{TRL_i}}$$

$$\text{For } IRL, I_{ij}^{CT} = \frac{\Delta SRL}{CT_{ij}} = \frac{SRL(TRL, IRL | IRL_{ij} = \overline{IRL_{ij}}) - SRL(TRL, IRL)}{CT_{\overline{IRL_{ij}}} - CT_{IRL_{ij}}}$$

- $CT_i = CT_{\overline{TRL_i}} - CT_{TRL_i}$: the cost for maturing TRL_i from its current readiness level to a target level $\overline{TRL_i}$ (the same for IRL_{ij}) .

Component Importance Measure 1 - System Capability Satisficing with Respect to Effort (I^LH)

The System

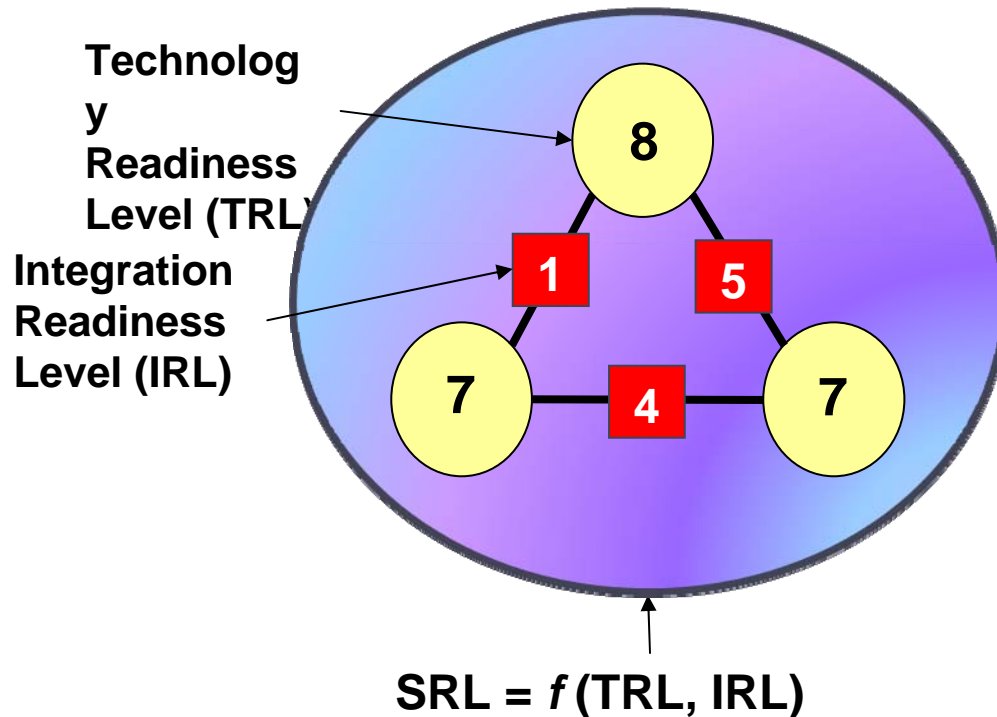

- Certain amount of



- Where to put the available **Labor-Hours** to achieve more system maturity?

Component Importance Measure 3

- System capability satisficing with respect to **labor-hours (I^{LH})**

$$\text{For } TRL, I_i^{LH} = \frac{\Delta SRL}{LH_i} = \frac{SRL(TRL, IRL \mid TRL_i = \overline{TRL_i}) - SRL(TRL, IRL)}{LH_{\overline{TRL_i}} - LH_{TRL_i}}$$

$$\text{For } IRL, I_{ij}^{LH} = \frac{\Delta SRL}{LH_{ij}} = \frac{SRL(TRL, IRL \mid IRL_{ij} = \overline{IRL_{ij}}) - SRL(TRL, IRL)}{LH_{\overline{IRL_{ij}}} - LH_{IRL_{ij}}}$$

- $LH_i = LH_{\overline{TRL_i}} - LH_{TRL_i}$: the labor-hours for maturing TRL_i from its current readiness level to a target level $\overline{TRL_i}$ (the same for IRL_{ij}).

Meaning of the Value of Measures

- I^P implies the effect of change in the **readiness level** of a given component on SRL.
- I^{CT} implies the effect of change in the **cost** to mature a given component on SRL.
- I^{LH} implies the effect of change in the **labor-hours (i.e., effort)** to mature a given component on SRL.
- The larger the measure value, the more important is the corresponding component.

System Diagram of A Notional Example

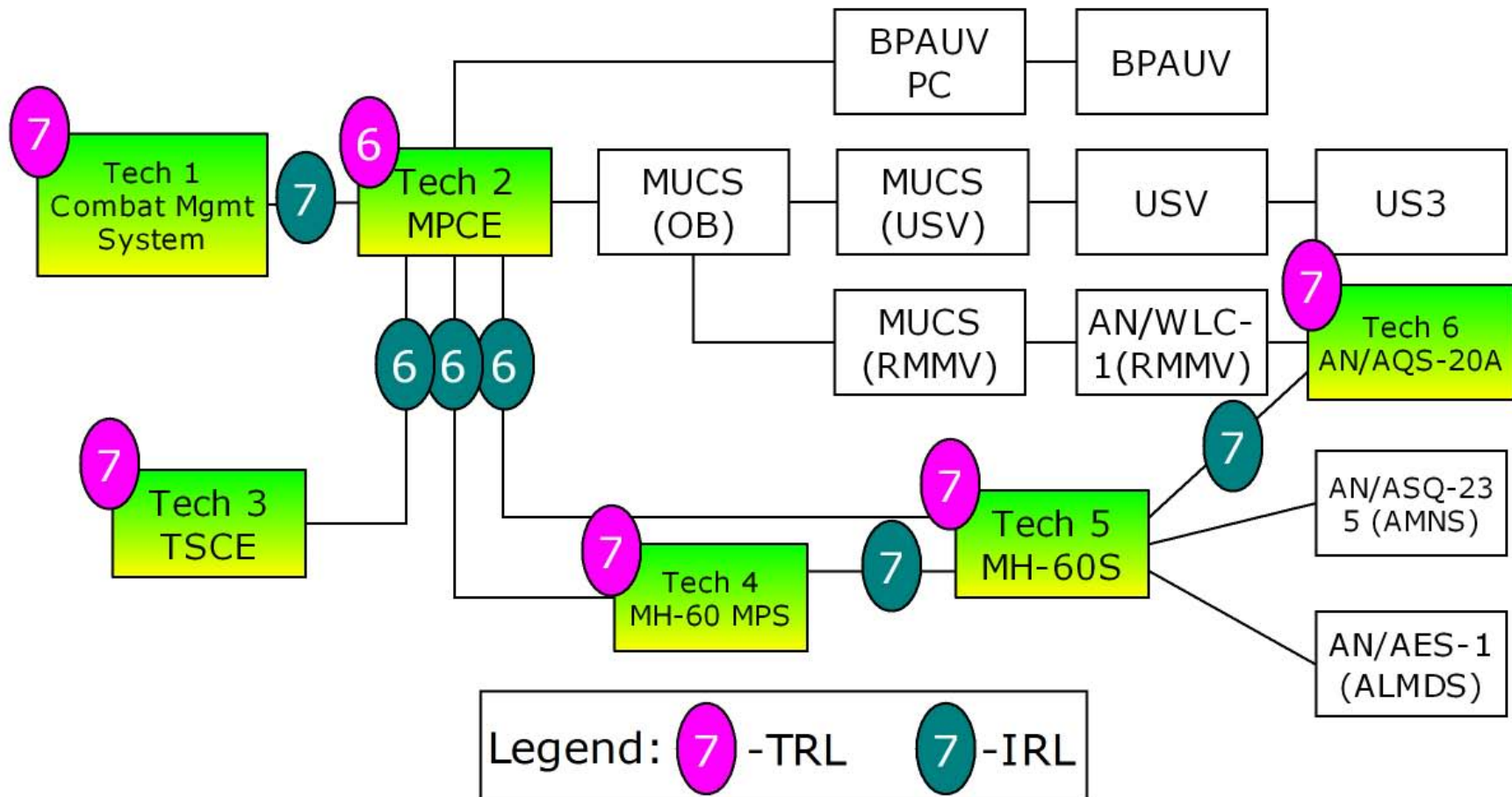

Assuming the Mine-Detection capability enabled by the combination of shaded components is the KPP of interest

Scenario 1 - Increasing Component Readiness by One Level

$$\overline{TRL}_i = TRL_i + 1$$

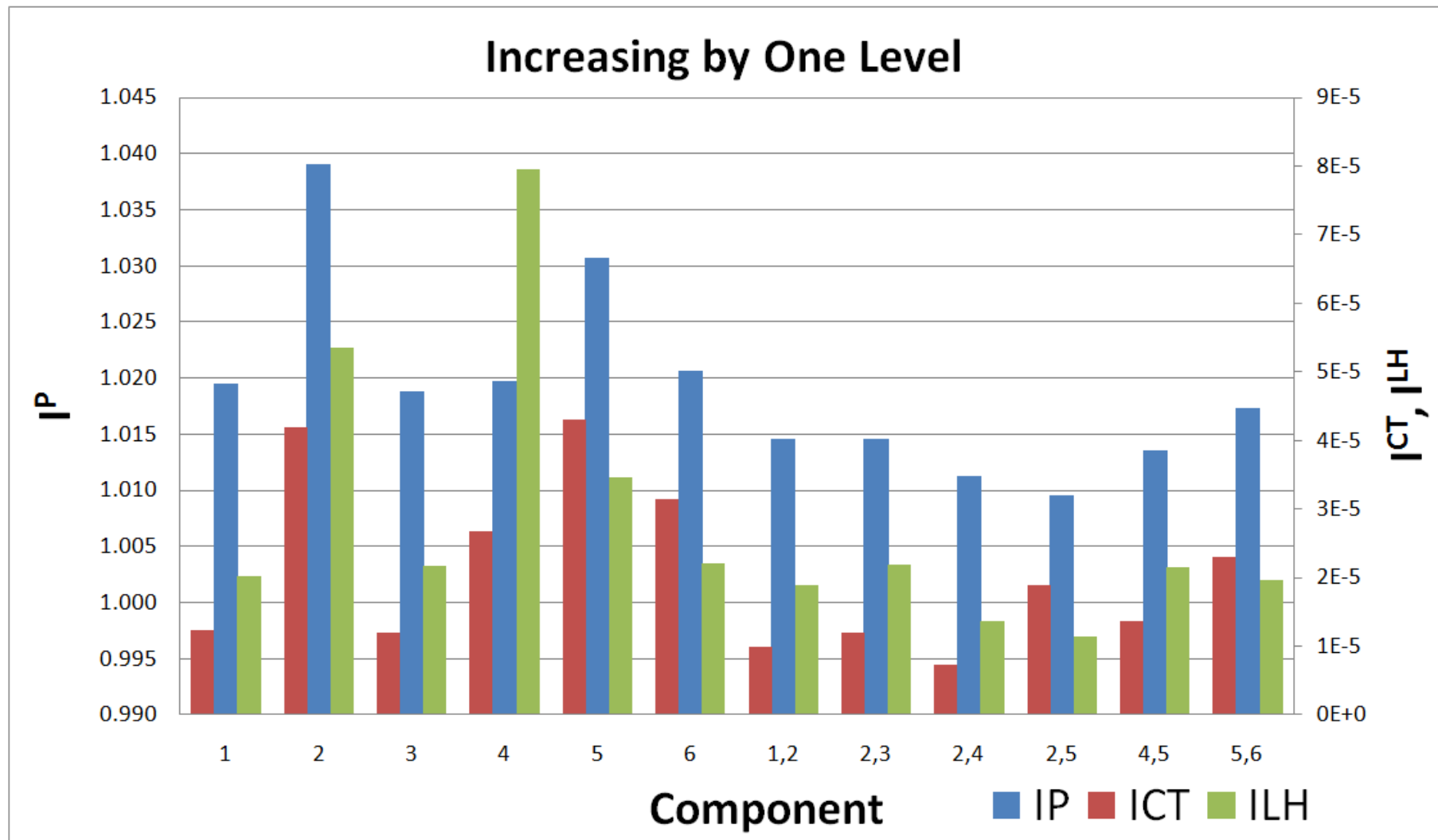

Scenario 2 - Fully Maturing Components $\overline{TRL}_i = 9$

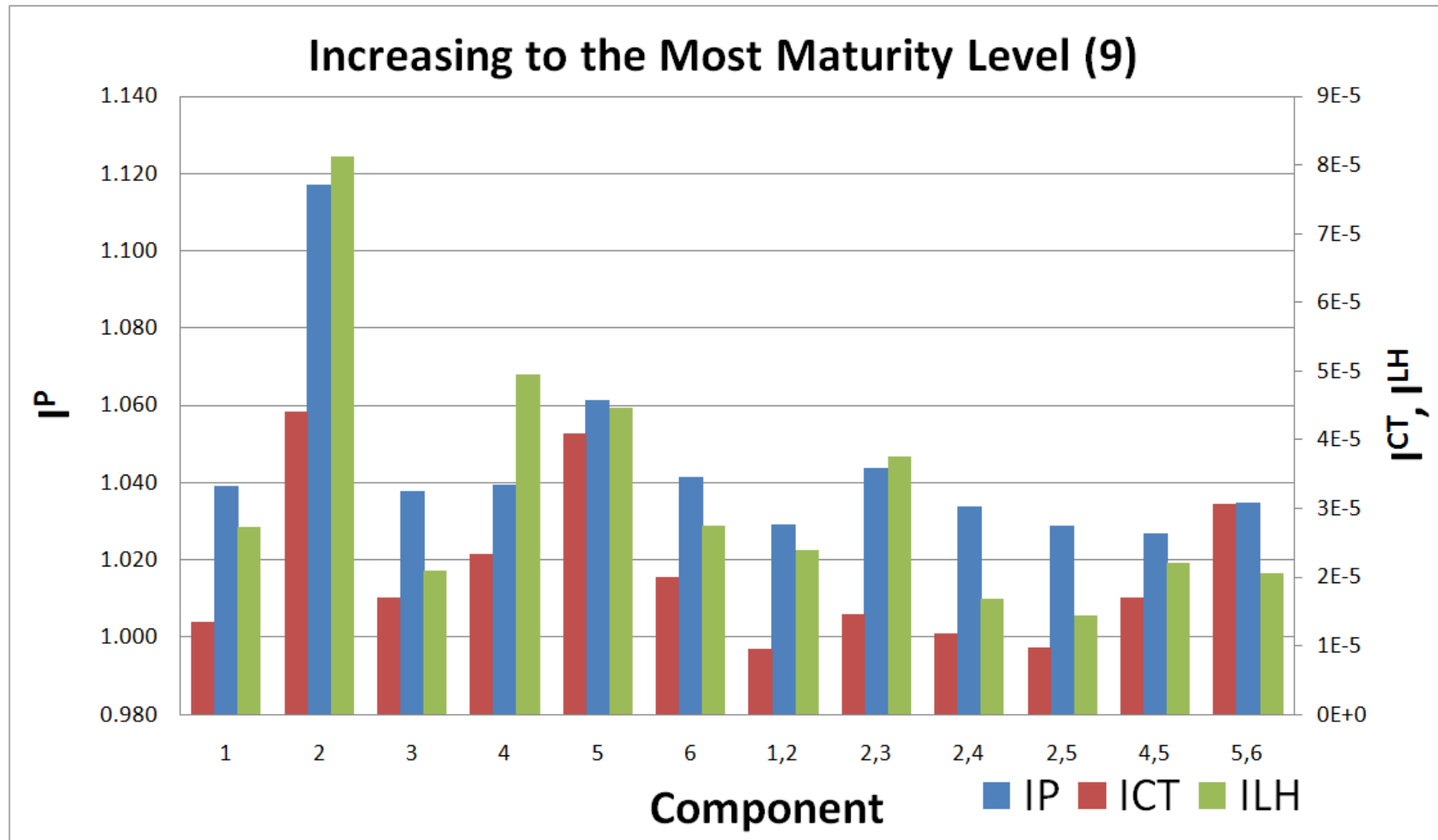

Conclusion

- **Technology components are generally more important than integration components**
 - How to coordinate the parallel development of these two kinds of components?
- **Component importance is ranked based on the current development maturity status**
 - Will importance rank change if the components are further matured?
 - Will a spiral methodology be needed to address component importance for the long system development life cycle?

Future Work

- **SRL enhancement for multi-function multi-capability (MFMC) systems development**
- **Earned readiness management**
- **SRL calculator plug-in to enterprise architecture**

Special Thanks

- **Office of Naval Research**
- **Naval Postgraduate School**
- **NAVSEA PMS 420**
- **Northrop Grumman**