

Scaled Debris Throw of Third Generation Norwegian/US Aircraft Shelters

By

Patricia M. Bowles
Kirk A. Marchand
John W. Strybos

ABSTRACT

A new aircraft shelter design is to be used in the construction of shelters throughout Norway. The new shelter is called the third generation Norwegian/US shelter due to structural characteristics common to both the third generation Norwegian shelter and the third generation US shelter. Since test data for debris and blast hazards do not exist for this new shelter configuration, NATO has recommended using current aircraft shelter siting criteria to establish safe locations for the newly constructed shelters. The current criteria are based on test results and conclusions from the DISTANT RUNNER program, which was a series of full scale explosion tests including both external and internal detonations of munitions stored in third generation US aircraft shelters. Although there are structural similarities between the third generation US shelters and the third generation Norwegian/US shelters, major differences between the front door systems and the lack of any rock rubble berm on the DISTANT RUNNER tested shelters raised some concern about applying the current criteria to siting of the new shelters. An initial 1/15 scale test series recently completed documents the effect of a rock rubble berm on the initial velocities and angles at which concrete debris leave a shelter following an internal detonation. Three different shelter designs and three explosive yields were tested in the series, which included tests with and without a rock rubble berm for all configurations. The tests provide meaningful data on the effect of placing berms on existing and new shelters and on the response differences between the three aircraft shelter designs.

Report Documentation Page

*Form Approved
OMB No. 0704-0188*

Public reporting burden for the collection of information is estimated to average 1 hour per response, including the time for reviewing instructions, searching existing data sources, gathering and maintaining the data needed, and completing and reviewing the collection of information. Send comments regarding this burden estimate or any other aspect of this collection of information, including suggestions for reducing this burden, to Washington Headquarters Services, Directorate for Information Operations and Reports, 1215 Jefferson Davis Highway, Suite 1204, Arlington VA 22202-4302. Respondents should be aware that notwithstanding any other provision of law, no person shall be subject to a penalty for failing to comply with a collection of information if it does not display a currently valid OMB control number.

1. REPORT DATE AUG 1990	2. REPORT TYPE	3. DATES COVERED 00-00-1990 to 00-00-1990			
4. TITLE AND SUBTITLE Scaled Debris Throw Tests of Norwegian/US Aircraft Shelters		5a. CONTRACT NUMBER			
		5b. GRANT NUMBER			
		5c. PROGRAM ELEMENT NUMBER			
6. AUTHOR(S)		5d. PROJECT NUMBER			
		5e. TASK NUMBER			
		5f. WORK UNIT NUMBER			
7. PERFORMING ORGANIZATION NAME(S) AND ADDRESS(ES) Southwest Research Institute, 6220 Culebra Road, San Antonio, TX, 78228		8. PERFORMING ORGANIZATION REPORT NUMBER			
9. SPONSORING/MONITORING AGENCY NAME(S) AND ADDRESS(ES)		10. SPONSOR/MONITOR'S ACRONYM(S)			
		11. SPONSOR/MONITOR'S REPORT NUMBER(S)			
12. DISTRIBUTION/AVAILABILITY STATEMENT Approved for public release; distribution unlimited					
13. SUPPLEMENTARY NOTES See also ADA235006, Volume 2. Minutes of the Explosives Safety Seminar (24th) Held in St. Louis, MO on 28-30 August 1990.					
14. ABSTRACT see report					
15. SUBJECT TERMS					
16. SECURITY CLASSIFICATION OF:			17. LIMITATION OF ABSTRACT Same as Report (SAR)	18. NUMBER OF PAGES 15	19a. NAME OF RESPONSIBLE PERSON
a. REPORT unclassified	b. ABSTRACT unclassified	c. THIS PAGE unclassified			

1.0 Introduction

A new aircraft shelter design proposed by Norway is being used in the construction of shelters throughout Norway. The new shelter is called the third generation Norwegian/US aircraft shelter due to structural characteristics common to both the third generation US shelter and the third generation Norwegian shelter. Since test data for debris and blast hazards do not exist for this new shelter configuration, NATO (North Atlantic Treaty Organization) has recommended using current aircraft shelter siting criteria to establish safe locations for the newly constructed shelters. The current criteria are based on test results and conclusions from the DISTANT RUNNER program (References 1-3), which was a series of full scale explosion tests including both external and internal detonations of munitions stored in third generation US aircraft shelters. Although there are structural similarities between the third generation US shelter and the third generation Norwegian/US aircraft shelter, some concern about applying the current criteria for siting the third generation Norwegian/US aircraft shelter has been raised.

An initial design comparison study conducted by Southwest Research Institute (SwRI) noted structural differences which would affect shelter breakup under internal loads (Reference 4). The study concluded that the major differences between the front door systems of the two shelters and the lack of any rock rubble berm on the shelters tested in DISTANT RUNNER should preclude utilization of current criteria in siting the new shelters. Since the comparisons made in this study could not form an adequate basis of information for establishing quantity-distance (Q-D) criteria for the new shelters, a number of recommendations were made. The recommendations were presented to develop a level of confidence necessary to establish new Q-D criteria.

The first recommendation was a series of small scale tests to determine the effect of the proposed rock rubble berm on the response of the shelter arch when subjected to internal explosive loading. Tests to be performed on models of the new shelter design and the DISTANT RUNNER type shelters were suggested. The Norwegian Defence Construction Service (NDCS) funded SwRI to conduct 1/15 scale tests of three different charge quantities in the two aforementioned shelters and in a Federal Republic of Germany (FRG) shelter, all in both a bermed (with rock rubble) and an unbermed (without rock rubble) configuration. That test series is the subject of this paper.

2.0 Objectives

The objective of the subject program was to document the effect of a rock rubble berm on the initial velocities and angles at which concrete debris leave a shelter following an internal detonation. To quantify this effect, the program included 1/15 scale model tests of three different shelter designs: the third generation Norwegian/US, the DISTANT RUNNER, and the FRG shelters. Three explosive yields were included to observe differences in breakup due to internal loading. All combinations of shelter and charge amount were to be tested with and without the rock rubble berm.

The models used were replica structures in diameter and crown height with limited section length. The doors were not replica panels, but were designed to have a mass and attachment which would provide a scaled quasistatic impulse replicating that expected in full scale. The door mass/unit area was designed to provide the correct scaled gas impulse for the limited section length and corresponding limited volume. This technique was chosen since a consistent two dimensional debris pattern was expected. The rear wall of each model was non-responding and rigid. The arches were simulated with modeled concrete and reinforcement.

The TNT equivalent 1/15 scale charges used were 0.09 Kg (0.2 lb), 0.27 Kg (0.6 lb), and 0.82 Kg (1.8 lb), corresponding in full scale to 307 Kg (675 lb), 909 Kg (2000 lb), and 2727 Kg (6000 lb) respectively. The original test plan included a larger 1/15 scale charge weight of 1.4 Kg (3 lb) instead of the 0.09 Kg (0.2 lb) charge; however, early tests indicated the shelters were so overpowered by this load that velocity and angle data would be not only difficult to obtain from the high speed film, but also may not be very useful in defining quantity-distance.

High speed cameras provided most of the data needed to meet the program objectives. In order to obtain quality velocity and angle data from the high speed films, three explosive sources were investigated. The use of high explosives as the source clearly limited the amount of data which could be extracted from film analysis. As a means to minimize the detonation flash and smoke which obscure the observance of debris movement, a hydrogen/oxygen mixture was tried as the source. Although good results were obtained from initial tests, the mixture proved to be too sensitive to early ignition and had to be discarded. The majority of the tests were conducted using a more stable propane/oxygen mixture as the source.

Although the objectives of this test program were simple in scope, the tests provided meaningful data on the effect of placing berms on existing and new shelters and on response differences between the three aircraft shelter designs. A secondary objective of the program was to add to the database of debris launch velocities from internal detonations in concrete structures. There may indeed be a way to relate all these data to enable prediction of launch velocity for a variety of structures without the need to test each time a new structural design is introduced. Further analysis toward this goal is recommended.

3.0 Modeling of Structures

The aircraft shelters were modeled in 1/15 scale. Table 1 summarizes a structural comparison of the three shelters tested. Tables 2, 3, and 4 list predicted loads on the full scale structures. The corrugations on the shelters were not modelled since commercially available corrugated steel did not have the correct corrugations and thickness. Also, the corrugated steel, while providing form work for full scale construction, is only 3 mm in thickness, or 0.3% of the total cross section. The tensile capacity of the liner was included in the steel area which was scaled to design the model reinforcement. The reinforcement spacing and number of layers were modeled as these are critical to the failure pattern. The vent panel weight was selected by calculating the venting and volume requirements necessary to produce the same scaled gas impulse for the particular load using methods

Table 1. Structural Comparison

Building Dimensions	Norwegian/US	DISTANT RUNNER	FRG
inside plan width	23.5 m	21.6 m	24.0
inside plan length	37.2 m	36.6 m	30.0
inside height at crown	7.04 m	8.43 m	7.75
volume	5079 m ³	5221 m ³	4338 m ³
Arch			
corrugation depth	360 mm	360 mm	none
arch thicknesses at base (including corrugation)	1360 mm	810 mm	1200 mm
arch thickness at crown (including corrugation)	810 mm	810 mm	1200 mm
total circumferential reinforcement (area/unit spacing)	3.8 mm ² /mm	1.31 mm ² /mm	1.59 mm ² /mm
total horizontal reinforcement (area/unit spacing)	2.5 mm ² /mm	1.31 mm ² /mm	1.59 mm ² /mm
typical circumferential reinforcement spacing	100 mm o.c.	150 mm o.c.	300 mm o.c.
typical horizontal reinforcement spacing	100 mm o.c.	150 mm o.c.	300 mm o.c.
corrugation material (connections detailing the same for both)	3 mm min. thickness	3 mm min. thickness	
arch base connection to footing	double legs at 100 mm o.c.	single #4 leg at 150 mm o.c.	double legs @ 300 mm o.c.
floor slab connection at arch base	slab overlaps footing	no slab overlap	no slab overlap
personnel door	near front door	at one side with protection wall	

1816

Table 1. Structural Comparison (Cont'd)

Front Door	Norwegian/US	DISTANT RUNNER	FRG
panels	hollow-core steel plates with internal stiffeners: interior plate-10 mm exterior plate-20 mm stiffeners-10 mm thickness-250 mm	composite steel/concrete supported by exterior trusses: steel plate-3.2 mm concrete-300 mm	composite steel/concrete: 20 mm steel outer plate and inner plate, 500 mm concrete in between
support against internal load	simple support top and bottom	track mechanism only	simple support bottom, sides and top free
weight/area	280 kg/m ²	770 kg/m ²	1520 kg/m ²

Table 2. Predicted Loads (307 Kg TNT)

	Norwegian/US	DISTANT RUNNER	FRG
* P _r (KPa)	400	407	737
i _r (KPa-sec)	1.633	1.647	2.115
t _d (sec)	.0082	.0081	.0057
** P _{qs} (KPa)	276	276	317
i _{qs} (KPa-sec)	31.49	39.07	43.75
t _{qs} (sec)	.229	.283	.276

Table 3. Predicted Loads (909 Kg TNT)

	Norwegian/US	DISTANT RUNNER	FRG
* P _r (KPa)	1138	1158	2198
i _r (KPa-sec)	3.627	3.654	4.747
t _d (sec)	.00638	.00631	.00432
** P _{qs} (KPa)	676	662	772
i _{qs} (KPa-sec)	58.6	69.6	79.37
t _{qs} (sec)	.173	.210	.206

Table 4. Predicted Loads (2727 Kg TNT)

	Norwegian/US	DISTANT RUNNER	FRG
* P _r (KPa)	3441	3509	6435
i _r (KPa-sec)	8.27	8.34	11.01
t _d (sec)	.00481	.00475	.00342
** P _{qs} (KPa)	1503	1503	1598
i _{qs} (KPa-sec)	91.0	108.3	120.99
t _{qs} (sec)	.121	.144	.151

* based on point source to door for hemispherical surface burst

** Reference 5

in Reference 5. The aggregate in the concrete was modeled and selected such that it could fit in between the spacing of the model reinforcing steel. The reinforcing steel was modeled using wire mesh and wire. The details of the reinforcing are discussed in Reference 6.

4.0 Testing

4.1 Test Setup

The test setup is shown in Figure 1. The test stand was used to support the shelter model and contained a chamber for the fuel/air mixture. The front of the test stand consisted of a rigid steel panel which formed the "rear wall" of each shelter tested. The vent panel of each shelter faced the rear end of the test stand. The test stand and shelter were placed inside a 3.0 meter tall by 3.0 meter wide by 1.8 meter deep reinforced concrete box culvert. Viewing ports were cut into the side and roof of the culvert for cameras and lights. Background panels, fabricated from 25 mm thick plywood, were painted and attached to the culvert. The background panels were painted blue with a 150 mm by 150 mm white grid pattern. The grid pattern was used for the data analysis. Two high speed cameras and a videotape camera were used to record each test. One high speed camera was focused on the side of the model and the other camera and the video camera were focused on the front of the test frame. The high speed cameras operated at between 1000 to 3000 frames per second depending on the available light conditions for the test. The high speed films were analyzed to determine the velocity and the trajectory of the debris. Blast gages were mounted in the test stand to record the blast pressure/impulse. Still camera coverage was used to provide before and after documentary pictures.

4.2 Data Analysis

The principal source of data consisted of 16mm high speed films recorded during each test. The films were obtained from two perpendicular cross-sectional views, one being a frontal orientation, the other a side view. The films from all tests were analyzed using an NAC brand Film Motion Analyzer. This machine projects the film image over a digital tablet which allows a local reference Cartesian coordinate system to be established for an individual frame. The position of objects within a frame can be represented by Cartesian coordinates. The coordinates from a number of frames can then be used to establish velocities for each visible piece of debris. Angles at which the debris leave the shelter were also measured from the high speed films.

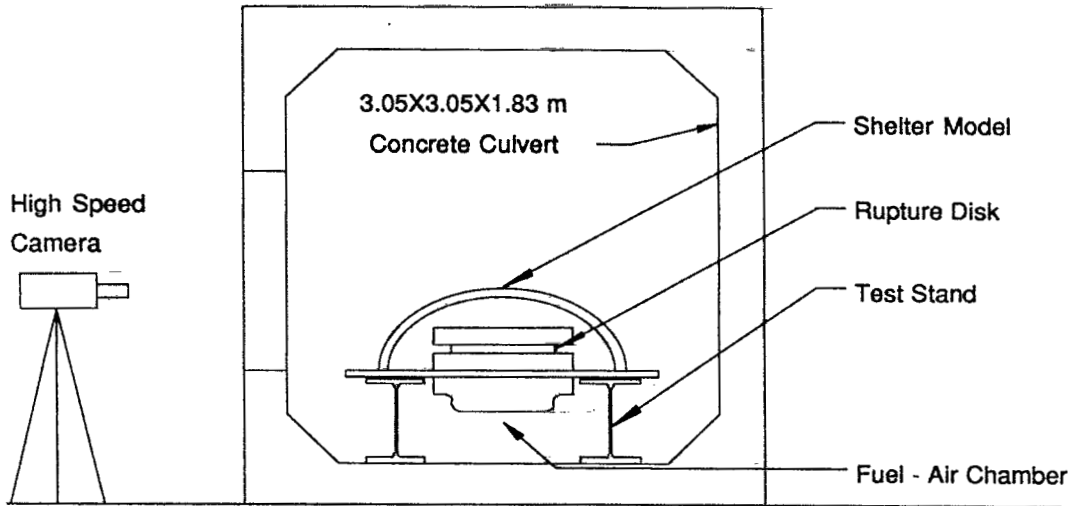

TEST SETUP
FRONT ELEVATION
(not to scale)

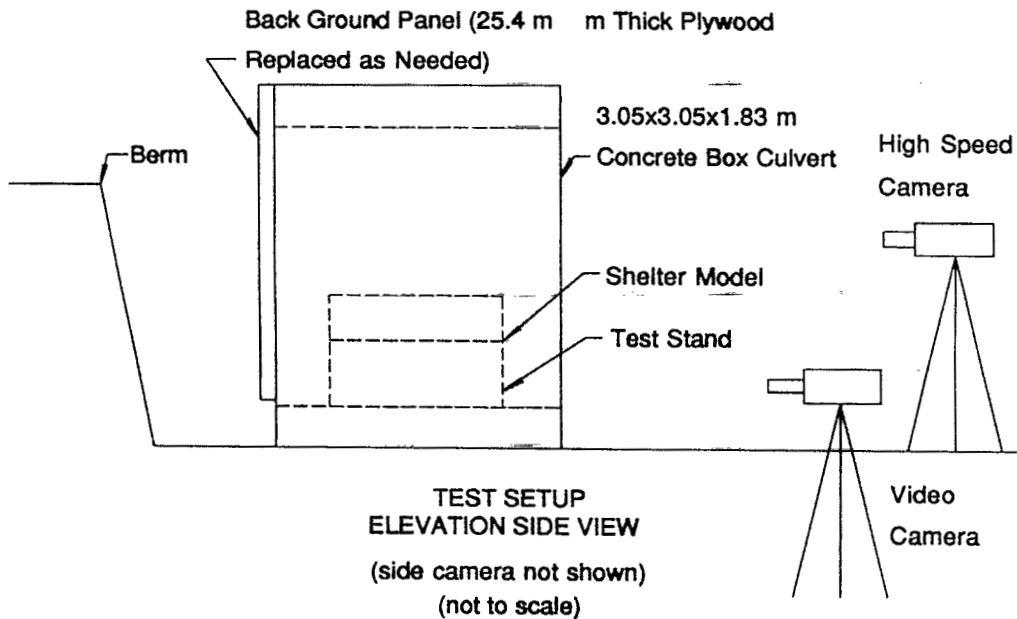

TEST SETUP
ELEVATION SIDE VIEW
(side camera not shown)
(not to scale)

Figure 1. Test Setup

5.0 Summary of Results

5.1 Test Summary

Table 5 presents a summary of data for the test series. It should be noted that while trajectory was not quantified based on film analysis, observed trajectories were observed to be essentially perpendicular to shelter surfaces in all tests. Therefore, initial debris trajectory becomes simply a function of shelter geometry.

Table 5. Summary of Results

Test No.	Shelter Type***	Berm	Expl* Yield (Kg)	Pred I ₀ (Pa-S)	Max Meas I ₀ (Pa-S)	Max Meas Debris Velocity (m/s)	Remarks
1	S	No	.27	4509	4137	42.3	3 pieces
2	U	No	.82	6068	6206	51.8	2 pieces
3	U	No	1.36	7378	7240	-	-
4	None	N/A	.27	-	-	-	-
5	S	No	.27	4509	4344		3 major pieces
6	U	No	.27	3930	4137	43.3	2 piece breakup
7	U	No	.82	6068	-	-	Pre-ignition
8	D	No	.27	4620	2758	42.0	2 piece breakup
9	G	No	.27	5309	4654	39.7	3 pieces
10	D	No	.82	7240	7240	78.7	2 pieces
11	G	No	.82	8067	7585	38.0	2 piece breakup
12	U	Yes	.27	3930	3792	37.1	2 pieces
13	U	Yes	.82	6068	6895	19.7**	2 pieces
14	D	Yes	.27	4620	2992	25.9	2 pieces
15	D	Yes	.82	7240	6854	77.1	2 pieces
16	G	Yes	.27	5309	4150	55.4	3 pieces
17	G	Yes	.82	8067	6998	43.6	2 pieces
18	U	Yes	.09	2101	1738	8.2	1 piece
19	D	Yes	.09	2606	1227	8.2	1 piece
20	D	No	.09	2606	1793	-	(No Data) 1 piece
21	G	No	.09	2919	1331	8.2	1 piece
22	G	Yes	.09	2919	1682	9.2	1 piece

* Note that tests 1-3 were C4 charges, all others were fuel/air.

** Early time measurements only

*** U=Third Generation Norwegian/US, D=DISTANT RUNNER, G=FRG, S=Source

It also should be noted that only tests 1-3 were conducted with C4 high explosive charges. While these charges better replicate the actual load-time functions expected in a full scale event, as described previously, they generated obscuring light and smoke such that their use was discarded in favor of the fuel/air detonations. Table 6 presents a comparison of the HE (C4) and fuel/air (propane/oxygen) tests.

As Table 6 shows, impulse measurements varied 5% from HE to fuel/air on the 0.27 Kg test and 11% on the 0.82 Kg test. Velocities on the 0.27 Kg test were only within 15%. These are reasonable values, and validate the use of the fuel/air substitute, even though the fuel/air time histories were typically 10-15 ms in duration, while the HE durations were about one-half of that value.

Table 6
Comparison of Fuel/Air and HE Tests

TNT Eq. Charge Weight (Kg)	Test No.	HE Impulse (I_Q) (Pa-s)	Fuel Air Impulse (I_p) (Pa-s)	Max. Meas. Velocity (m/s)
.27	S1	4137	4344	42.3
	S5			57.4
.82	U2	6206	6895	51.8
	U13*			-

* Bermed test

5.2 Observed Failure Patterns

The pattern of shelter breakup can be generalized in three distinct groupings. The groups are defined by the size and amount of significant debris objects resulting from a shelter test. The debris generated during a test are directly related to the shelter breakup pattern. Factors which affect the breakup pattern for a test include shelter type and geometry, explosive weight, and the degree of fixity at the base. The largest contiguous pieces of debris were considered in the pattern groupings. Some shelters broke into three major pieces, two flanking segments and a crest segment (Group 1). Other shelters only broke into two pieces with the separation occurring at the crest (Group 2). The third type of breakup pattern occurred at the lowest charge weight only (Group 3). The shelter was driven upward as a single piece after rupturing at the basal support on both sides.

The third generation Norwegian/US shelter breakup pattern was identical to the DISTANT RUNNER shelter and falls into the category of two major debris segments. This is true for both 0.27 Kg and 0.82 Kg charge weights. Before and after pictures of Test 6, a 0.27 Kg charge in a third generation Norwegian/US shelter model, demonstrate this type of breakup in Figure 2. The FRG shelters behaved somewhat differently than the third generation Norwegian/US and

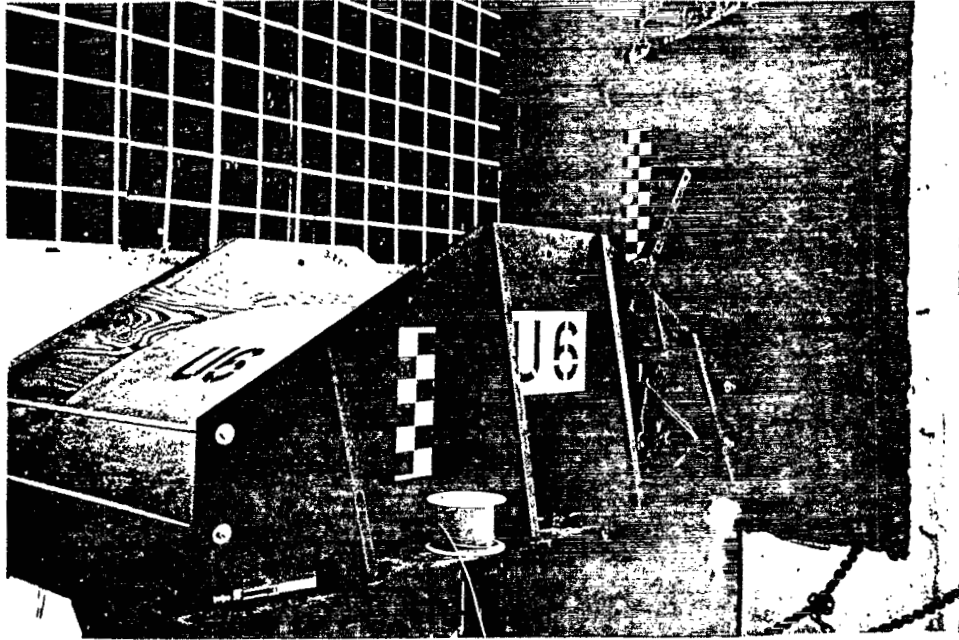

Test Setup



Resultant Debris

Figure 2. Results of Test 6 Using 0.27 Kg Charge

DISTANT RUNNER shelters. At the 0.82 Kg charge weight, the FRG shelters were noted to break up into two major segments (as with the third generation Norwegian/US and DISTANT RUNNER). However, at the 0.27 Kg charge weight the FRG shelter typically broke into three major segments. At the lowest charge weight (0.09 Kg) all three types of shelters broke at the base as mentioned above and remained in one major piece. Figure 3 illustrates this type of breakup for a bermed third generation Norwegian/US shelter model.

Since the model shelters were originally designed to replicate response due to combined blast and quasistatic load, the breakup pattern observed for the lowest charge weight (principally quasistatic load) may not be valid. It is unlikely that the basal separation would be observed in full scale shelters. It is presumed that the failure at the connections occurred as a late time response, where inertial effects would not be important and where the static arch strength at the base is important. These observations, however, may be interpreted to represent the actual structural response of the shelter without regard for the basal separation. In effect, the shelter would not be expected to break up under these loading conditions.

5.3 Observed Differences Between Bermed and Unbermed Shelters

Table 7 presents a comparison of the bermed and unbermed tests. There appears to be no noticeable trend towards higher impulses or velocities when the berm is added. Additional film analysis is recommended to both confirm velocities and examine trajectories.

Table 7
Comparison of Bermed and Unbermed Impulses and Debris Velocities

Charge Wt. (Kg)	Test No.	Berm	Impulse (Pa-s)	Debris Velocity (m/s)
.09	U18	Yes	1738	8.2
	D20	No	1793	-
	D19	Yes	1227	8.2
	G21	No	1331	8.2
	G22	Yes	1682	9.2
	.27	U6	No	4137
U12		Yes	3792	37.1
D8		No	2758	42.0
D14		Yes	2972	25.9
G9		No	4654	39.7
G16		Yes	4150	55.4
.82	U7	No	-	-
	U13	Yes	6895	19.7*
	D10	No	7240	78.7
	D15	Yes	6854	77.1
	G11	No	7585	38.0*
	G17	Yes	6998	43.6

* Early time measurements only

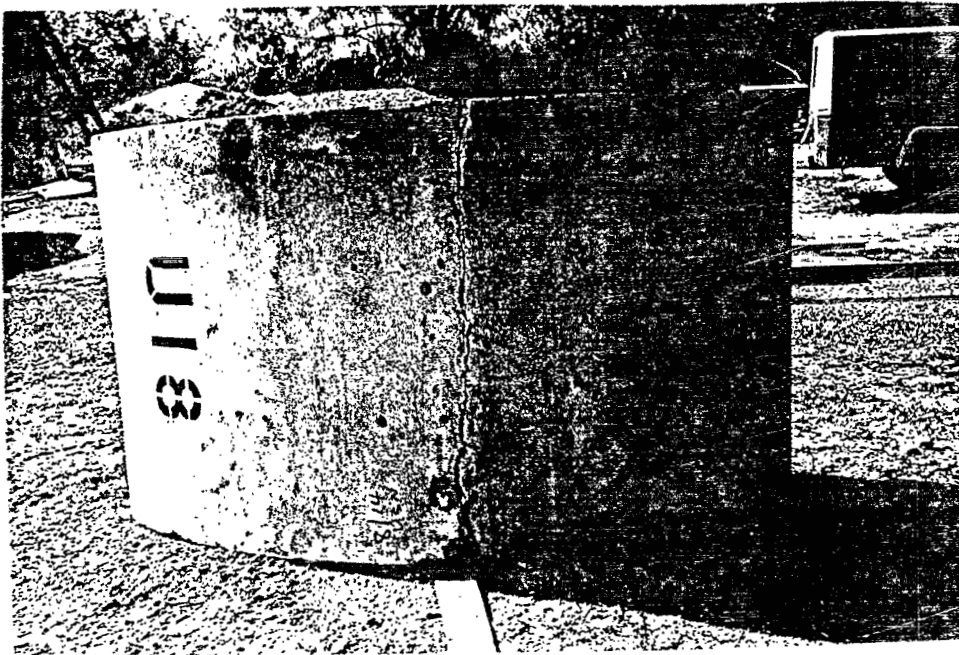
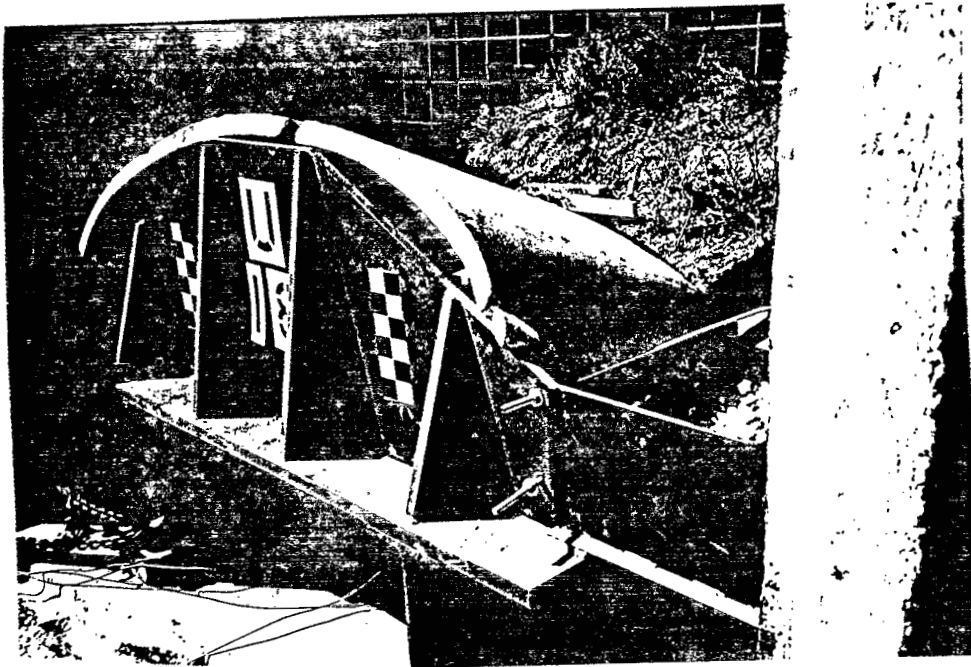

**Figure 3. Typical Breakup for 0.09 Kg Charge Weight
(Test 18)**

6.0 Recommendations

Qualitative observations on angles and failure patterns, along with measured velocities, indicate the response of the shelters is not greatly affected by the presence of the rock rubble berm against the shelter sides. There were some slight offsets of initial failure lines when the berm was in place, but the debris velocities did not change significantly. Based on a cursory analysis of the test results, several key refinements should be made. These items are presented in this section.

A pivotal parameter for this study was the quasistatic impulse. Since the debris velocities following an internal detonation are largely defined by this impulse, that was what needed to be scaled properly in the tests. One must remember the 1/15 scale shelters were models of a section of each shelter. The length was not 1/15 of the full scale shelter arch length. Thus, to obtain the correct load, the vent panel used in place of the door was designed in each case to remain in place long enough to attain the proper scaled quasistatic impulse. The quasistatic impulse prediction to be matched for each test was calculated using methods in Reference 5, allowing the covered vent areas (doors) to vent according to their mass/unit area. Calculations in Reference 3 for the DISTANT RUNNER shelter were made assuming immediate venting through the doors and the vent openings at the top of the arch and, thus, are lower than the predictions used for these tests. Velocities calculated using these impulses are lower than those expected and measured from the SwRI tests. Since the large database of DISTANT RUNNER debris characteristics indicates many impact distances which would agree with higher velocities than the one reported Event 4 arch velocity (measured from film), further investigation of the load prediction method is highly recommended. The actual gas load duration (and, thus, immediate venting or delayed venting) in the DISTANT RUNNER tests and in the 1/15 scale SwRI tests needs to be resolved.

The next step recommended in the original design comparison study (Reference 4) was to perform larger scale tests (1/4 or 1/3) of the third generation Norwegian/US shelter with models of the whole shelter, including the front door and frame. The larger scale models would be tested, again with and without the rock rubble berm, using properly scaled amounts of the same three full scale charge weights examined in this study. These tests would include debris mapping as well as measurement of velocities and documentation of failure patterns. This test series should then be followed by a detailed analysis before establishing quantity-distance for the new shelter design.

A number of recent tests have provided velocity data for debris resulting from internal detonations in reinforced concrete structures, both aboveground (or unbermed) and buried (or bermed). It is most desirable to determine a relationship between the amount of cover on a structure (i.e. concrete plus berm thickness), charge amount, and debris launch velocity. One attempt to relate the launch velocity to the scaled cover is documented in Reference 7. After more detailed analysis of the 1/15 scale test results and performance of the larger scale tests, these data should be added to the data summarized in Reference 7, and a rigorous effort to refine this velocity relationship needs to be undertaken. If such a relationship can be established, it would eliminate the need to fund specific testing and analysis every time a new aircraft shelter design is introduced. This is indeed a worthwhile goal for all involved in the safe siting of structures.

References

1. Flory, Robert A., "DISTANT RUNNER Results: A 5 Event High Explosive Test Series Involving U.S. Air Force 3rd Generation Aircraft Shelters," Minutes of the Twentieth Explosives Safety Seminar, Volume II, pp. 1817-1835.
2. Ward, Dr. Jerry M., "DISTANT RUNNER - Debris Recovery and Analysis Program for Events 4 and 5," Minutes of the Twentieth Explosives Safety Seminar, Volume II, pp. 1837-1881.
3. Ward, Dr. Jerry M., "DISTANT RUNNER - Debris Recovery and Analysis Program for Events 4 and 5," Naval Surface Weapons Center, White Oak Laboratory, Silver Spring, MD, April 1982.
4. Whitney, M., Bowles, P. and Polcyn, M., "Aircraft Shelter Design Comparison," Final Report for SwRI Project 06-2061, prepared for Norwegian Defence Construction Service, Oslo, Norway, March 1988.
5. Ayvazyan, H., Dede, M., Dobbs, N. (Amman & Whitney), Whitney, M., Bowles, P. and Baker, W. (Southwest Research Institute), "Structures to Resist the Effects of Accidental Explosions, Volume II: Blast, Fragment, and Shock Loads," Special Publication ARLCD-SP-84001, December 1986.
6. Strybos, J.W., Bowles, P.M., Lewis, M.J., and Marchand, K.A., "Scaled Debris Throw of Third Generation Norwegian/US Aircraft Shelters: Data Summary Report," SwRI Project 06-2673, prepared for The Norwegian Defence Construction Service, Oslo, Norway, December 1989.
7. Helseth, Einar S., "Underground Ammunition Storage: Model Test in Scale 1:100 in Sand," Norwegian Defence Construction Service, Fortifikatorisk Notat Nr. 160/82, August 1982.