

**Cost Savings Using Stirrup Reinforcement Instead of Laced Wall Reinforcement Per UFC 3-340-02 (TM 5-1300) December, 2008.**

*Darell Lawver, P.E.  
Weidlinger Associates, Inc.  
399 W. El Camino Real, Suite 200  
Mountain View, Calif. 94040  
650-230-0320  
650-230-0209 (fax)  
[lawver@wai.com](mailto:lawver@wai.com)*

*Jim Weeks, P.E.,  
Weidlinger Associates, Inc.  
6301 Indian School Rd. NE, Suite 501  
Albuquerque, NM 87110  
505-349-2832  
212-497-2220 (fax)  
[weeks@wai.com](mailto:weeks@wai.com)*

*Stephen Forman.  
B & W Pantex, LLC  
PO Box 30020  
Amarillo, TX 79120  
806-477-6153  
806-477-5558(fax)  
[SForman@pantex.com](mailto:SForman@pantex.com)*

*Robert Lackey, P. E.  
B & W Pantex, LLC  
PO Box 30020  
Amarillo, TX 79120  
806-477-7087  
806-477-5558 (fax)  
[rlackey@pantex.com](mailto:rlackey@pantex.com)*

*Larry Faria, P. E.  
CH2M HILL  
12377 Merit Drive, Suite 1000  
Dallas, TX 75251  
972.663.2312  
972.385.0846 (fax)  
[Larry.Faria@ch2m.com](mailto:Larry.Faria@ch2m.com)*

## Report Documentation Page

*Form Approved*  
*OMB No. 0704-0188*

Public reporting burden for the collection of information is estimated to average 1 hour per response, including the time for reviewing instructions, searching existing data sources, gathering and maintaining the data needed, and completing and reviewing the collection of information. Send comments regarding this burden estimate or any other aspect of this collection of information, including suggestions for reducing this burden, to Washington Headquarters Services, Directorate for Information Operations and Reports, 1215 Jefferson Davis Highway, Suite 1204, Arlington VA 22202-4302. Respondents should be aware that notwithstanding any other provision of law, no person shall be subject to a penalty for failing to comply with a collection of information if it does not display a currently valid OMB control number.

1. REPORT DATE <b>JUL 2010</b>	2. REPORT TYPE <b>N/A</b>	3. DATES COVERED <b>-</b>	
4. TITLE AND SUBTITLE <b>Cost Savings Using Stirrup Reinforcement Instead of Laced Wall Reinforcement Per UFC 3-340-02 (TM 5-1300) December, 2008</b>		5a. CONTRACT NUMBER	
		5b. GRANT NUMBER	
		5c. PROGRAM ELEMENT NUMBER	
6. AUTHOR(S)		5d. PROJECT NUMBER	
		5e. TASK NUMBER	
		5f. WORK UNIT NUMBER	
7. PERFORMING ORGANIZATION NAME(S) AND ADDRESS(ES) <b>Weidlinger Associates, Inc. 399 W. El Camino Real, Suite 200 Mountain View, Calif. 94040</b>		8. PERFORMING ORGANIZATION REPORT NUMBER	
9. SPONSORING/MONITORING AGENCY NAME(S) AND ADDRESS(ES)		10. SPONSOR/MONITOR'S ACRONYM(S)	
		11. SPONSOR/MONITOR'S REPORT NUMBER(S)	
12. DISTRIBUTION/AVAILABILITY STATEMENT <b>Approved for public release, distribution unlimited</b>			
13. SUPPLEMENTARY NOTES <b>See also ADM002313. Department of Defense Explosives Safety Board Seminar (34th) held in Portland, Oregon on 13-15 July 2010, The original document contains color images.</b>			
14. ABSTRACT			
15. SUBJECT TERMS			
16. SECURITY CLASSIFICATION OF:			17. LIMITATION OF ABSTRACT <b>SAR</b>
a. REPORT <b>unclassified</b>	b. ABSTRACT <b>unclassified</b>	c. THIS PAGE <b>unclassified</b>	
			18. NUMBER OF PAGES <b>24</b>
			19a. NAME OF RESPONSIBLE PERSON

Weidlinger Associates® Inc. began the blast resistant design of an explosive processing facility in 2005. The facility was designed using the 1990 version of TM5-1300 “Structures to Resist the Effects of Accidental Explosions”. Due to the close proximity of the charge locations to the processing bay walls, the wall designs incorporated lacing reinforcement. Upon release of UFC 3-340-02 “Structures to Resist the Effects of Accidental Explosions” in December of 2008, the design of the facility was revised to decrease the cost of construction. The revision to the design used the new Section 4-22 “Design of Non-Laced Reinforced Slabs” Type C stirrups to replace the lacing in the walls. Once the redesign was complete, CH2M HILL developed a cost study report that documented the cost savings realized by the redesign effort. This paper will discuss the wall design and redesign process and provide cost data for comparison of the savings provided by switching from lacing to Type C stirrups.

## **Introduction**

The design of explosive processing facilities for Department of Defense (DoD), Department of Energy (DOE), other government organizations and government contractors has been primarily governed by the November 1990 version of TM5-1300 [1] for almost two decades since its publication. The document contains prescriptive and recommended design procedures for the design of structures to resist the effects of accidental explosions. The procedures were developed from explosive testing – extensive in some areas, but very limited in others - and good engineering practice. Since the publication of TM5-1300, the state of the art methods in computational fluid dynamics and structural analysis have improved tremendously in their ability to more accurately predict the response of structural components to blast loading. This has been verified and validated through many government-sponsored test programs [2-11]. These test programs have also improved the accuracy of empirical and simplified engineering tools to predict the response of structural components to blast loading [12-14]. Due to the prescriptive nature of TM5-1300, this body of knowledge is generally not available for use in design. Blast testing of systems is often required to demonstrate their ability to meet the intent of the standard when they fall short of meeting the strict prescriptive requirements of TM5-1300. The testing is not only very costly, but also time consuming which may prevent users from meeting aggressive design and construction schedules. Therefore, most engineering projects conform to the prescriptive requirements of the TM5-1300 standards. In this manner, the design can be reviewed through conventional government channels and delays caused by the testing process are avoided.

## **Design Using the TM5-1300, November 1990, Publication**

The design of the explosive processing facility began in 2005 using the November 1990, TM5-1300 publication as the governing design code. The design of the walls and roof slabs required that the slabs resist the creation of hazardous spall, avoid breaching, prevent direct and diagonal shear failure, and limit global deflections of the slab itself. TM5-1300 required lacing when the scaled standoff distance,  $Z$  equal to the standoff from face of wall to center of charge divided by the cube root of the explosive weight, was less than or equal to 1. Table 1 below displays the  $Z = 1$  standoffs for various charge sizes. As the table indicates, the standoff from the center of the charge to the face of wall is relatively large even for small charge sizes and can greatly increase the size of the bay. A study was done to evaluate the design with a larger total footprint to allow

for more standoff and avoid lacing. However, that design required more space to construct the building and increased construction cost. Therefore, lacing was used in the original design.

Table 1. Scaled Range, Z, equal to 1 for Various Charge Sizes

Charge Size (lbs)	Standoff (ft)
10	2.15
50	3.68
100	4.64
200	5.85
500	7.94
1000	10.0

The TM5-1300 approach to slab design is to start with a flexural response mode using Single-Degree-of-Freedom (SDOF) methods and then design the direct and diagonal shear reinforcement to develop their full flexural capacity. This approach can be termed as “the flexural fail first approach” and is based on attempting to develop a ductile failure mode. This approach may have major deficiencies when designing very thick slabs with span to depth ratios of less than five. This is due to the fact that thick slabs do not respond in a pure flexural mode. SDOF methods tend to overestimate the response and require excessive flexural reinforcement [11]. This, in turn, leads to high ultimate shear capacity and, consequently, excessive shear reinforcement. In addition to the flexural steel, middle bars are put in the slabs of processing bays to resist any tension load that is produced by gas pressure build up before venting from the bay occurs. Finite element calculations for very thick walls to large near contact charges have confirmed the response mode to depend much more on local dilation of the concrete and local confining steel layout than on global flexural bending modes [15]. This is an area where future code changes would benefit both the cost and reliability of thick slabs designed to resist blast loading.

After the wall is initially designed using the flexural approach, it must be designed to resist production of hazardous spall and breach. The current approaches to resist spall and breaching are based on empirical equations [1, 12]. These equations determine if spall or breach can occur for a given concrete wall thickness, design charge weight, and standoff. If the slab can resist breach but not spall, a spall plate may be added to the wall face away from the blast threat to prevent spall. TM 5-1300 provides a method for designing the spall plate and its attachment to the wall.

In order to reduce steel congestion and allow for manual placement of reinforcing bars for the design of the explosive facility, the maximum rebar size was limited to a No. 11 bar. An attempt was also made to maximize the use of common reinforcing bar sizes and spacing to simplify construction. This approach can be problematic if the matching reinforcement greatly strengthens a wall in flexure, since a large penalty may be paid in shear reinforcement. The slab can get very congested when the flexural steel, tension steel, diagonal shear steel, and direct shear steel is placed in the wall. Furthermore, the TM5-1300 document prohibits the use of couplers without testing, so very long lap splices create even more congestion. Due to the fact that stirrup spacing cannot exceed the depth divided by two (where depth is dependent on the



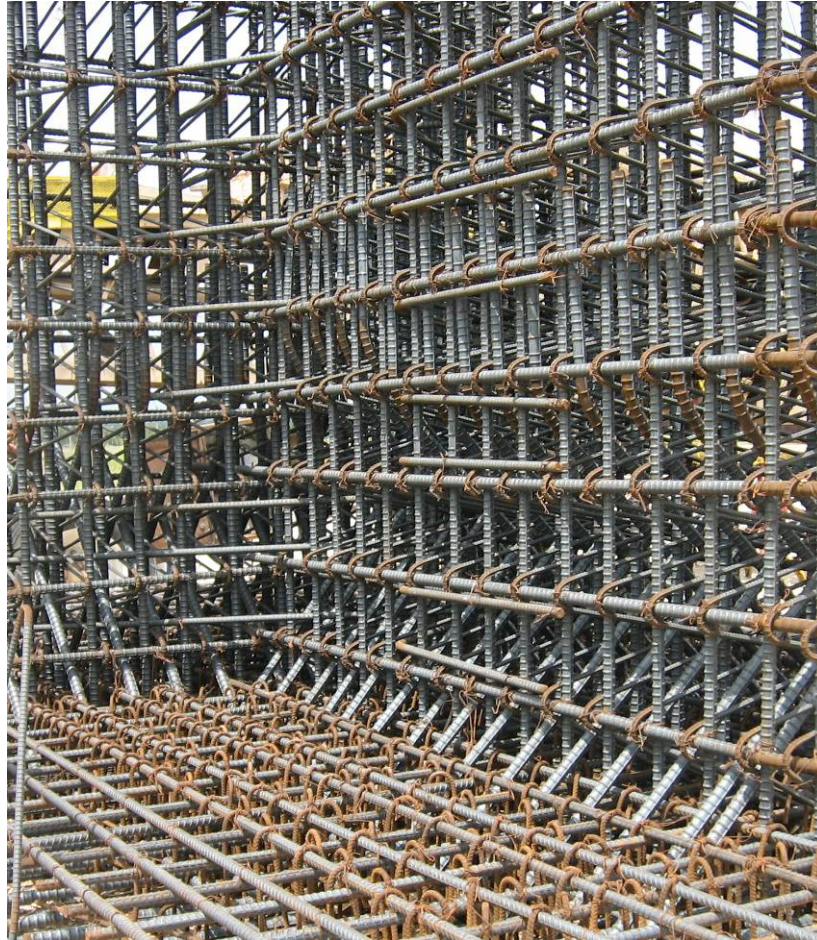

Figure 2. Laced Wall Construction

### **New Stirrup Shear Provisions of UFC 3-340-02, December 2008, Publication**

Sections 4-22 and 4-66.3 of UFC 3-340-02, December 2008, describe the conditions required for the use of stirrups in lieu of lacing. The Type C stirrup with 180 degree bent legs at each end can be used for all charge separations allowed in the manual, even when  $Z$  is less than 1, and for rotations up to 12 degrees. While the design of the walls and slabs in the explosive processing facility was based on SDOF calculations with rotations of less than 2 degrees for personnel protection, the standoff was often less than a  $Z$  equal to 1. Therefore, the Type C stirrup configuration was used to replace lacing in the design of walls with these near contact charges. Figure 3 illustrates the previous wall section modified for Type C stirrups. Stirrup size and layout is a function of the element's flexural capacity, while the size of rebar used is a function of the required area and spacing of the stirrups. The maximum and minimum size of stirrup bars are No. 8 and No. 3, respectively, while the spacing between stirrups is limited to a maximum of  $d/2$  or  $d_c/2$  for type I and type II or III cross-sections, respectively. The type I, II, and III cross-sections are defined in UFC 3-340-02. The use of stirrups in lieu of lacing is based on recent testing [13, 14]. Where recent is defined as anything after the November 1990 version of TM5-1300 was published.

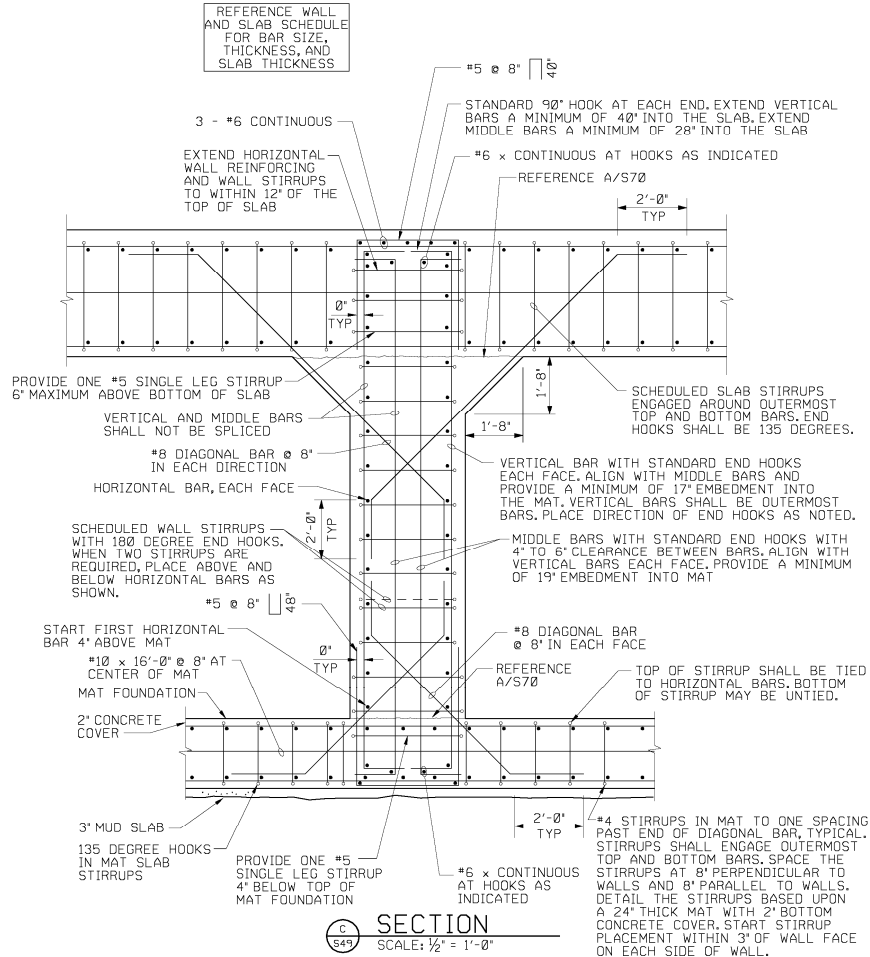

Figure 3. Stirrup Wall Construction

### Revised Design Based on UFC 3-340-02 Stirrup Provisions

Once UFC 3-340-02 was approved to replace TM5-1300 as the design code of record in January 2009, the slabs in the processing facility were redesigned using Type C stirrups instead of lacing. The laced design proved troublesome in many ways during the pre-bid design process. First, many contractors would not even bid on the project due to the laced design. Second, the lack of experience in constructing laced slabs required higher contingency costs for those contractors willing to bid on the project. Finally, the actual effort and time required to build the structure was greatly increased by the laced construction. The redesign with stirrups instead of lacing was based on keeping the bay and slab layout unchanged due to the potential negative impact on architectural, mechanical, electrical and process systems that would cascade through the design effort. This meant that only the interior reinforcement could be changed in the design. While the primary effort would be based on replacing the diagonal shear capacity of the lacing with stirrups, there were impacts due to the new placement of the primary reinforcing that required consideration. The fact that a stirrup solution to resist diagonal shear could allow the primary rebar to be placed closer to the wall's exterior surface and thus, increase the flexural capacity of the wall was evaluated in the redesign effort. The revised design with stirrups, including providing complete quality controlled checked calculations, was completed in about four weeks.

## **Impact of Design Change**

After the revised design was completed, CH2M HILL evaluated the cost differential. The revised design was estimated to save approximately 580,000 pounds of reinforcement and 22,000 man-hours of construction effort. In addition, it is estimated that more contractors would bid on the project since conventional construction methods could be employed with the elimination of lacing. The weight of steel and labor savings was estimated to reduce construction costs by about \$2 million dollars.

## **Conclusion**

The blast resistant design of an explosive processing facility was completed using the laced approach as outlined in TM5-1300, November 1990. Later, the design was revised in accordance with the new UFC 3-340-02, December 2008, approach using stirrups in lieu of lacing. The result was significant savings in total steel weight and man-hours to construct the structure. In addition, the conventional construction with stirrups is familiar to many contractors and allows for more cost competitive bidding and less construction risk. This project is an example where incorporating updated test results into the standards can produce more cost effective blast resistant structures that provide the level of safety required for explosive processing protection.

## **References**

1. US Army TM 5-1300, Navy NAVFAC P-397, or Air Force AFR 88-22, *Structures to Resist the Effects of Accidental Explosions*, November 1990.
2. Tennant, D., H. Levine and J. Mould, "Prediction of Static and Dynamic Response of Reinforced Concrete Slabs Through Failure Using a Rate-Dependent Three Invariant Softening Model for Concrete," Proc. of the 8th Internat. Symp. On Interaction of the Effects of Munitions with Structures, McLean, VA, April 21-25, 1997.
3. D. Lawver, R. Daddazio, G. J. Oh, C. K. B. Lee, A. Pifko and M. Stanley, "Simulating The Response of Composite Reinforced Floor Slabs Subjected To Blast Loading," 2003 ASME International Mechanical Engineering Congress and RD&D Expo, November 2003.
4. D. Lawver, R. Daddazio, G. J. Oh, A. Pifko and M. Stanley, "Composite Retrofits of Reinforced Concrete Slabs to Resist Blast Loading", 74<sup>th</sup> Shock and Vibration Symposium, October 2003.
5. D. Lawver, D. Vaughan and H. Levine, "Response of AISC Steel Column Sections To Blast Loading," PVP Vol. 454, Problems Involving Thermal-Hydraulics, Liquid Sloshing, and Extreme Loads on Structures, July 2003.
6. Levine, H. S., D. Tennant and F. Wong, "Response of Buried Vertical Steel Cylinders to High Intensity Airblast Loadings," Proc. 1991 ASME-PVP Conference, Symp. on Structural Dynamics Produced by Extreme Loading Conditions, San Diego, CA, June 23-27, 1991.
7. Levine, H. S. and D. Tennant, "Dynamic Buckling of Buried Steel Cylinders," Proc. 1991 ASME Winter Annual Mtg, Symp. on Dynamic Response of Structures to High Energy Excitations, AMD-Vol. 127/PVP-Vol. 225, Atlanta, GA, Dec. 1-6, 1991.
8. Tennant, D. and H. Levine, "Response of Embedded Cylindrical and Articulated Structures to Airblast and Ground Shock Loads," Proc. 62nd Shock and Vibration Symposium, Springfield, VA, October 29-31, 1991.

9. Tennant, D. and H. Levine, "Response Predictions of Reinforced Concrete Structures Subjected to Combined Airblast and Fragment Loadings," Proceedings of the 68th Shock and Vibration Symposium, Hunts Valley, MD, November 3-6, 1997.
10. Tennant D., H. S. Levine, and J. C. Mould, Jr., "Prediction of Static and Dynamic Response of Reinforced Concrete Slabs using a Rate-Dependent Three Invariant Softening Model for Concrete," Proceedings of the 8th International Symposium on the Interaction of the Effects of Munitions with Structures, April 22-25, 1997.
11. Lawver, D., Oneto, R., Stanley, M., Tennant D., Weeks, J., *FLEX FE Models and Full Scale Tests of Blast Loaded Reinforced Concrete Columns*, Thirty-Third DOD Explosive Safety Seminar Proceedings, Palm Springs, CA, August 2008.
12. K. A. Marchand and B.T Plenge, AFRL-MN-EG-TR-1998-7032, *Concrete Hard Target Spall and Breach Model*, March 1998.
13. Zehrt, W. H., Jr., Woodson, S. C., and Beck, D. C., *Investigation of Army TM 5-1300/NAVFAC P-397/AFR 8-22 Bar Bend Requirements for Single Leg Stirrups used as Diagonal Tension Reinforcement*, Thirty-Second DOD Explosives Safety Seminar Proceedings, Philadelphia, PA, August 2006.
14. Woodson, S. C. and Zehrt, W. H., Jr., *Investigation of Army TM 5-1300/NAVFAC P-397/AFR 88-22 Diagonal Tension Requirements at Low Scaled Distances*, Thirty-Second DOD Explosives Safety Seminar Proceedings, Philadelphia, PA, August 2006.
15. *Full Cell Blast Evaluation For Lawrence Livermore National Laboratory, Site 300 EMPC Facility*, Weidlinger Associates<sup>®</sup> Inc., Final Report, July 29, 2005.
16. ACI-318, Building Code Requirements for Reinforced Concrete with Commentary, American Concrete Institute.

# Cost Savings Using Stirrup Reinforcement Instead of Laced Wall Reinforcement Per UFC 3-340-02 (TM 5-1300) December, 2008

Darell Lawver, PE, SE

Jim Weeks, PE

Steve Forman

Robert Lackey, PE

Larry Faria, PE

For

34th DoD Explosives Safety Seminar

Portland, Oregon

July 13-15, 2010



[www.wai.com](http://www.wai.com)

New York, NY • Cambridge, MA • Mountain View, CA •  
Washington, DC • Marina Del Rey, CA • Albuquerque, NM



# Outline of Discussion

- ◆ Introduction
- ◆ Design Using Lacing
- ◆ Blast Effects Testing
- ◆ Design Using Stirrups
- ◆ Conclusions



# Introduction

- ◆ **Explosive Processing Facility 2005 Design**
  - ◆ November 1990 TM5-1300 Blast Design Code
  - ◆ Studied Layout with  $Z > 1$  and  $Z < 1$
  - ◆  $Z < 1$  Chosen And Lacing Required Per Standards
  - ◆ Research into History of Lacing Requirement Yielded Little Verifiable Information
- ◆ **Research Since 1990 Publication Demonstrated Effectiveness of Stirrups**
  - ◆ Many DoD Sponsored Weapons Tests on Structures Without Lacing or Diagonal Bars
  - ◆ Tests Included Internal Detonations – Both Cased and Uncased Weapons
  - ◆ US Army WES performed tests to specifically demonstrate performance of stirrups



# Design Using Lacing

- ◆ Lacing Increases Congestion
- ◆ Lacing Reduces Number of Contractors Who Will Bid
- ◆ Lap splices in lacing difficult to place
- ◆ TM5-1300 Basically Prohibits Use of Couplers
- ◆ Lacing Severely Impacts Placement of Primary Rebar in Slabs
  - ◆ Lacing Must Wrap Horizontal Bars
  - ◆ Primary Bars Inside Horizontal Bars



# 2D Lacing Drawing

- ◆ In 2D, Lacing Does not Appear Difficult
- ◆ Thick Walls Provide "Handroom"

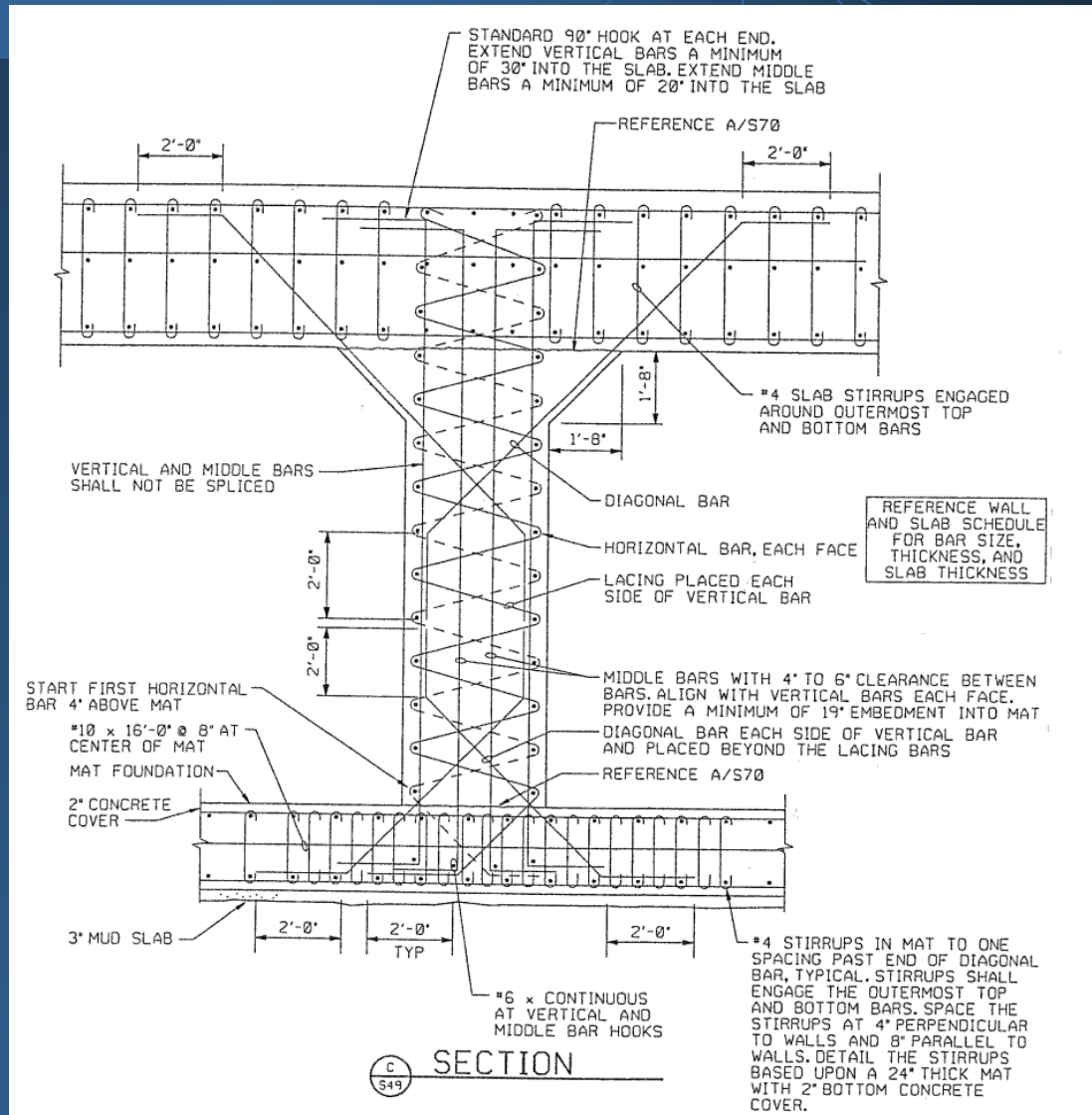

# Lacing Congestion

- ◆ Placement of Horizontal and Vertical Bars a Challenge
- ◆ Typical Construction Tolerances Can Impact Design
- ◆ Diagonal Bars Difficult to Place
- ◆ Wall Corners Extremely Difficult

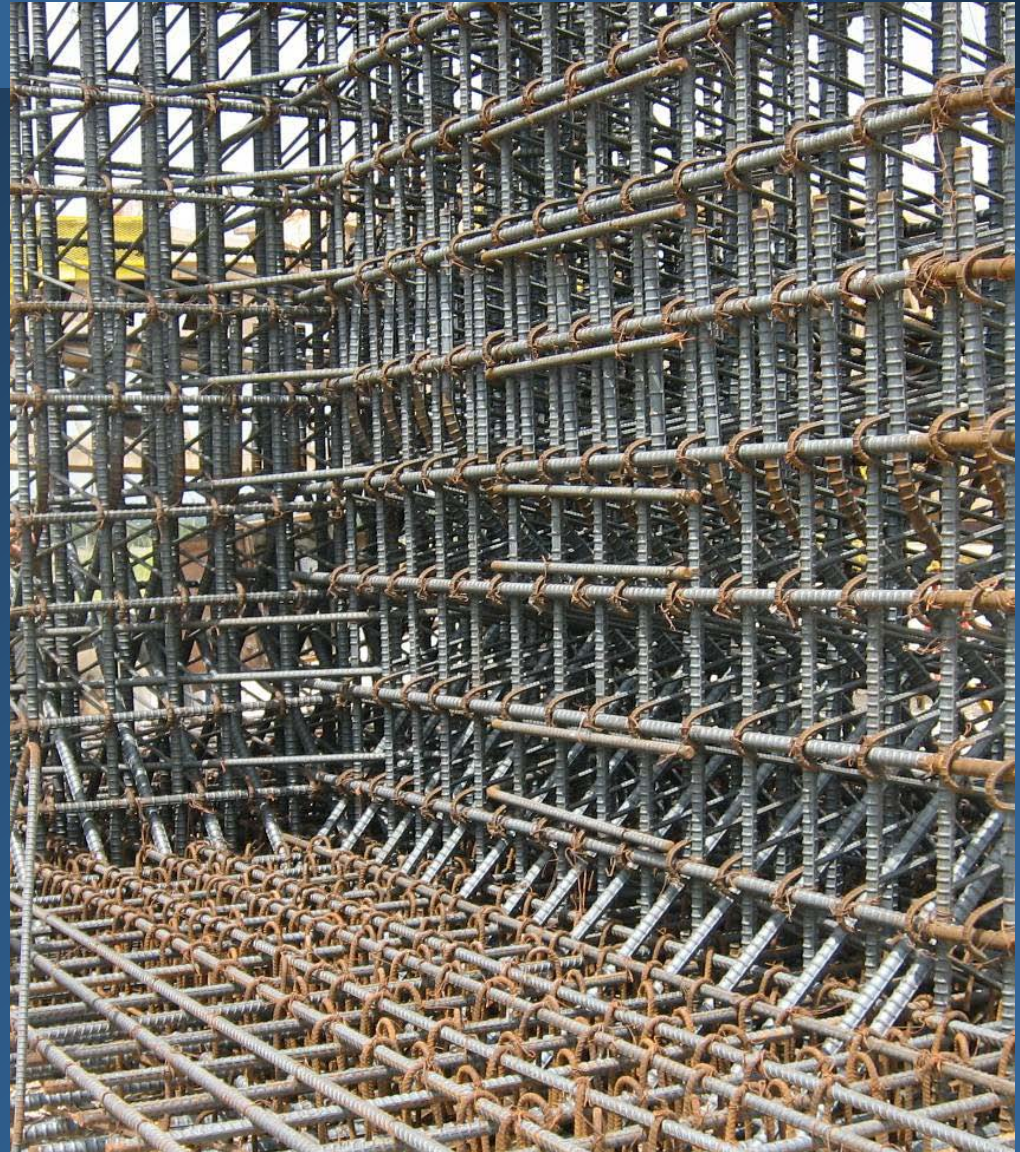

# Lacing Congestion

- ◆ Placement of Horizontal and Vertical Bars a Challenge
- ◆ Vertical Bars Inside Horizontal Bars

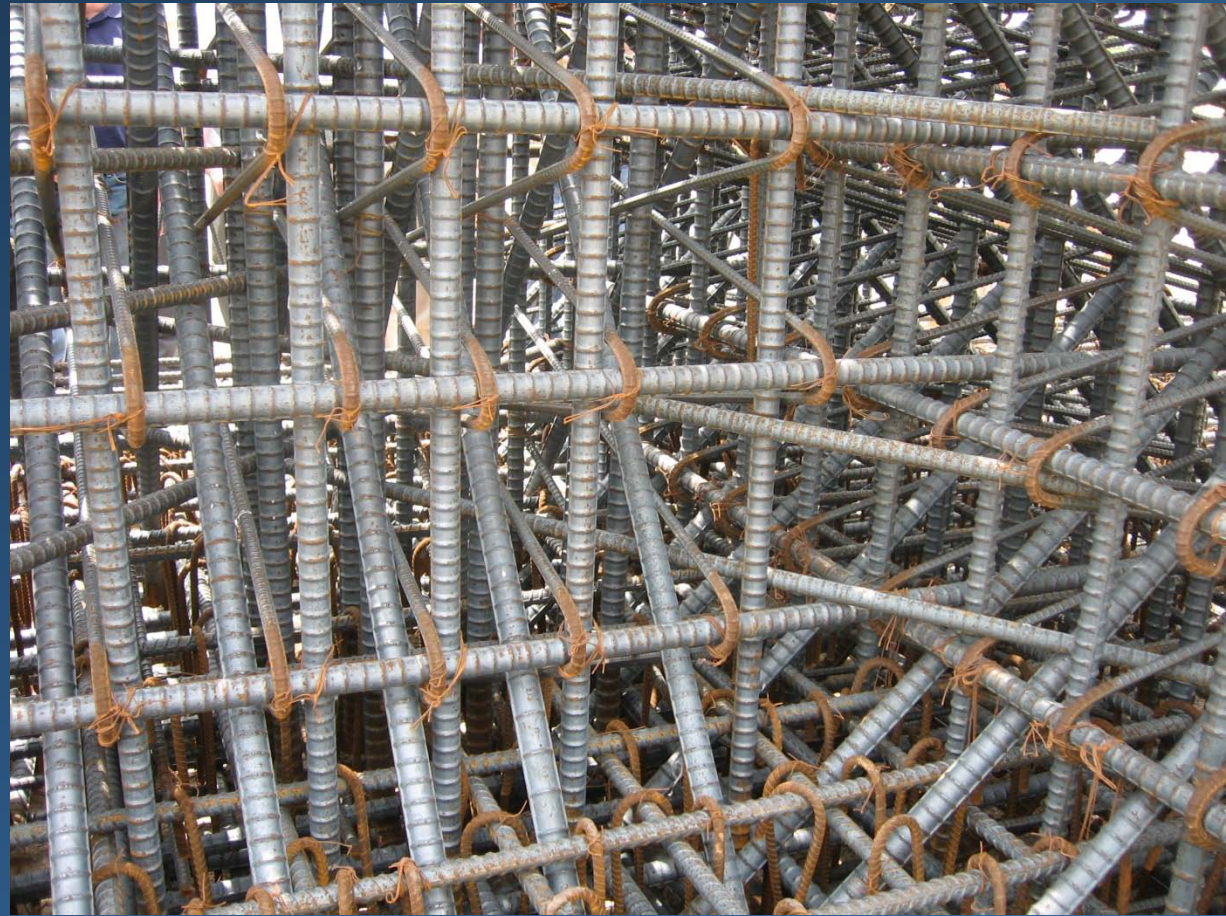

# Lacing Congestion

- ◆ Diagonal Bars  
Difficult to Place
- ◆ Wall Corners  
Extremely  
Difficult
- ◆ Both Vertical and  
Horizontal  
Diagonal Bars  
Intersect

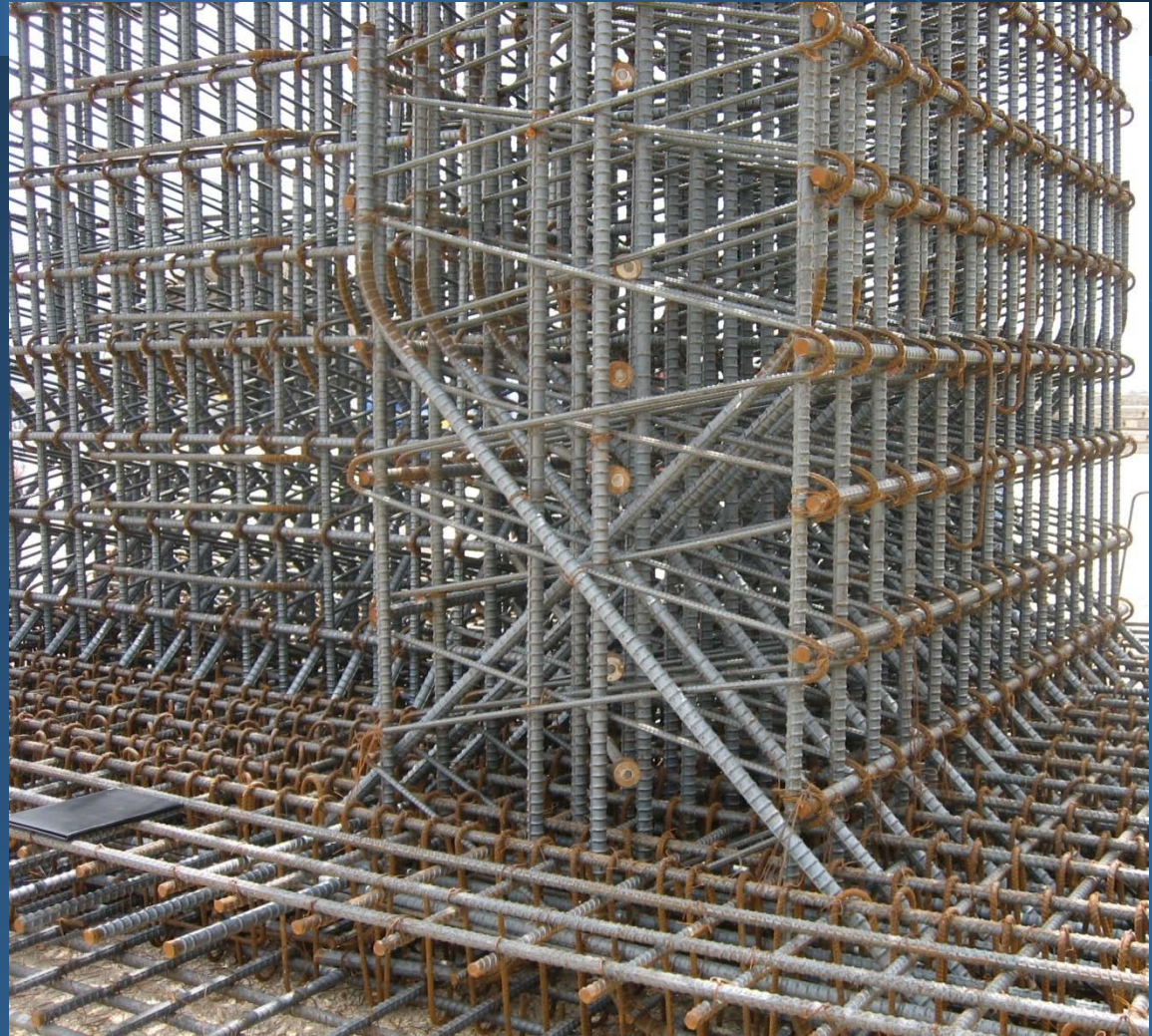

# Lacing Congestion

- ◆ Construction Tolerances Can Impact Design Calculations



# Testing with Stirrups

- ◆ Woodson, S. C., Gaube, W. H., and Knight, T. C., "Alternative Shear Reinforcement Guidelines for Blast-Resistance Design," 24<sup>th</sup> DDESB Seminar, 1990.
- ◆ Woodson, S. C., "Response Limits of Blast-Resistant Slabs", Technical Report SL-90-11, US Army Waterways Experiment Station, Vicksburg, MS, October 1990
- ◆ Woodson, S. C., "Lacing Versus Stirrups – An Experimental Study of Shear Reinforcement in Blast-Resistant Structures," Technical Report SL-92-2, US Army Engineer Waterways Experiment Station, Vicksburg, MS, March 1992.



# Weapon Effects

- ◆ Advanced Analysis and Testing Performed for DoD Projects
  - ◆ Internal Detonations Tested and Analyzed
  - ◆ Structures Often Do Not Have Diagonal Bars or Lacing
  - ◆  $Z$  Often Less than 1

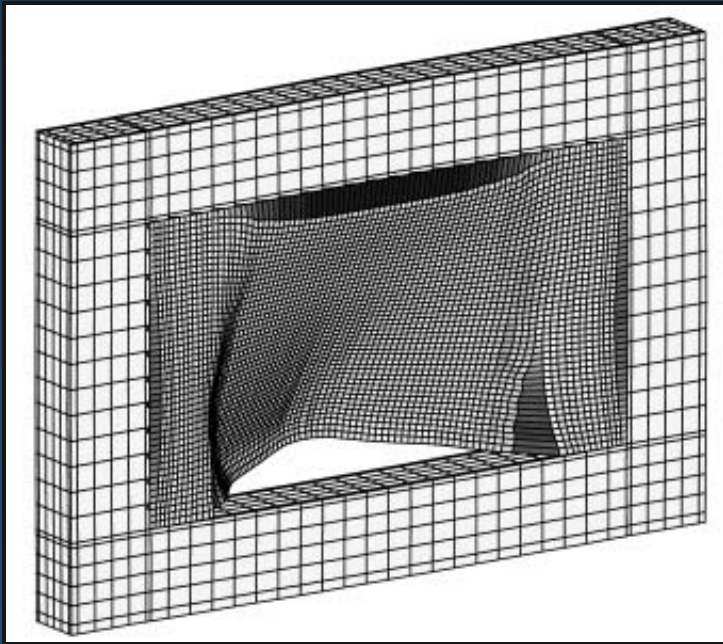

# Reinforced Concrete Column Blast Tests

- ◆ 6 Axial Loaded Reinforced Concrete Columns
- ◆ No Diagonal Bars or Lacing
- ◆ Variations in Stirrups Layout For Given Column and Threat



# Response For Test 1



Weidlinger Associates<sup>®</sup> Inc.  
[www.wai.com](http://www.wai.com)

# Response For Test 2 – Closer Stirrups



**TM 5-1300 would not allow this design**



Weidlinger Associates<sup>®</sup> Inc.  
[www.wai.com](http://www.wai.com)

# Stirrup Design – UFC 3-340-02, 2008

- ◆ Stirrups Much Easier to Place
- ◆ Stirrups Allow For Flexible Primary Rebar Placement
- ◆ Stirrups are Standard Construction

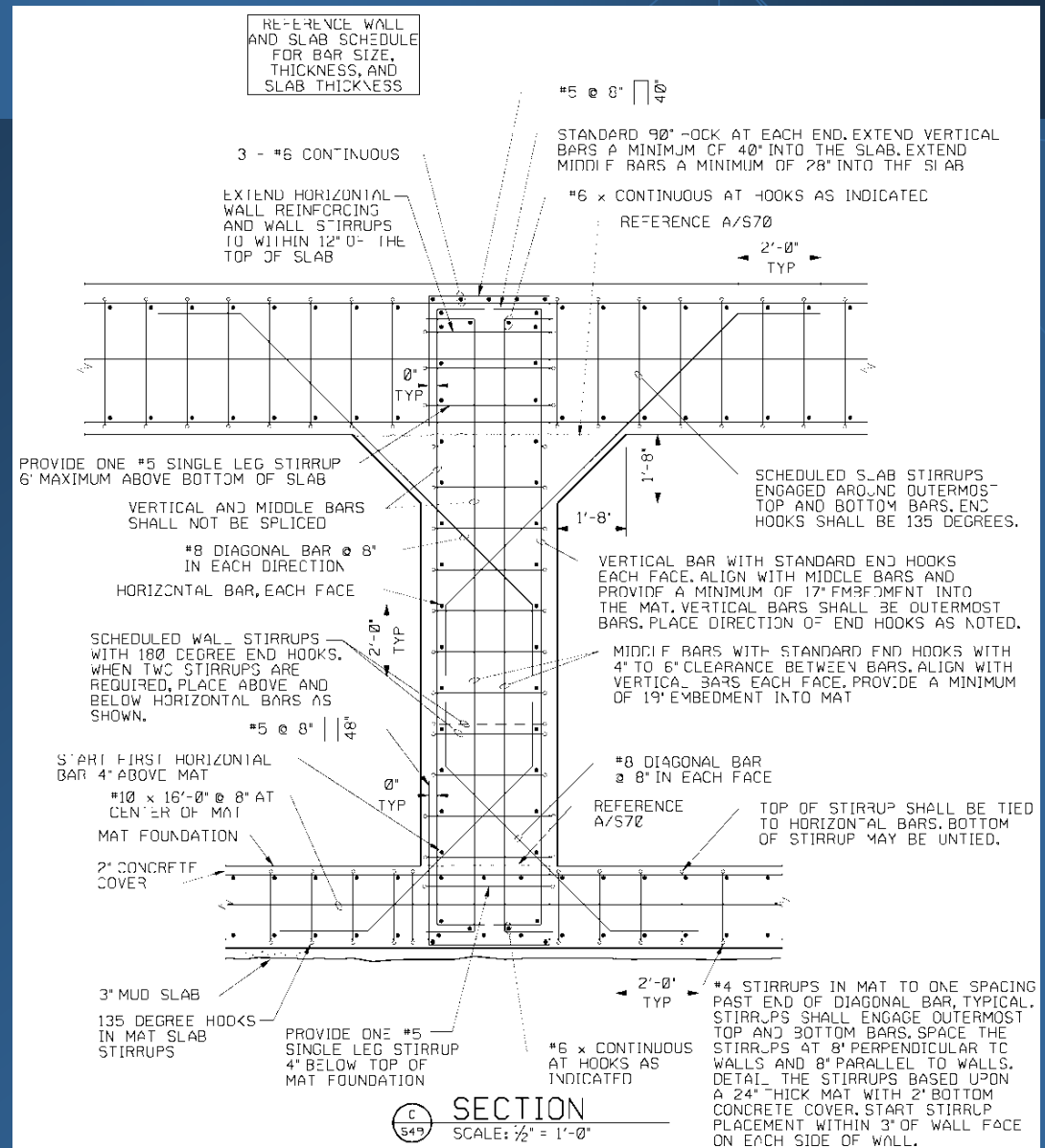

# Conclusions

## ◆ Summary of Results

- ◆ Initial Design Based on November 1990 TM5-1300
- ◆ Lacing Required Due to  $Z < 1$
- ◆ Lacing Increase Congestion, Complexity of Construction and Limited Contractors Bidding on Project
- ◆ Testing Has Proven That Stirrups Can Perform in  $Z < 1$  Range
- ◆ Revised Design per UFC 3-340-02, December 2008
- ◆ Design Used Stirrups in Lieu of Lacing
- ◆ Revised Design Estimated to Save \$2M in Construction Costs & 22,000 Man Hours of Effort

