

STATUS REPORT ON THE DEVELOPMENT OF A TWO-PHASE  
MOLECULAR BEAM

W. B. Stephenson

M. Kinslow

September 1979

Distribution Unlimited

**ARNOLD ENGINEERING DEVELOPMENT CENTER  
ARNOLD AIR FORCE STATION, TENNESSEE  
AIR FORCE SYSTEMS COMMAND  
UNITED STATES AIR FORCE**

# Report Documentation Page

*Form Approved  
OMB No. 0704-0188*

Public reporting burden for the collection of information is estimated to average 1 hour per response, including the time for reviewing instructions, searching existing data sources, gathering and maintaining the data needed, and completing and reviewing the collection of information. Send comments regarding this burden estimate or any other aspect of this collection of information, including suggestions for reducing this burden, to Washington Headquarters Services, Directorate for Information Operations and Reports, 1215 Jefferson Davis Highway, Suite 1204, Arlington VA 22202-4302. Respondents should be aware that notwithstanding any other provision of law, no person shall be subject to a penalty for failing to comply with a collection of information if it does not display a currently valid OMB control number.

1. REPORT DATE <b>SEP 1979</b>	2. REPORT TYPE	3. DATES COVERED <b>00-00-1979 to 00-00-1979</b>			
4. TITLE AND SUBTITLE <b>Status Report On The Development Of A Two-Phase Molecular Beam</b>		5a. CONTRACT NUMBER			
		5b. GRANT NUMBER			
		5c. PROGRAM ELEMENT NUMBER			
6. AUTHOR(S)		5d. PROJECT NUMBER			
		5e. TASK NUMBER			
		5f. WORK UNIT NUMBER			
7. PERFORMING ORGANIZATION NAME(S) AND ADDRESS(ES) <b>ARO, Inc., AEDC Division, A Sverdrup Corporation Company, Arnold Air Force Station, TN, 37389</b>		8. PERFORMING ORGANIZATION REPORT NUMBER			
9. SPONSORING/MONITORING AGENCY NAME(S) AND ADDRESS(ES)		10. SPONSOR/MONITOR'S ACRONYM(S)			
		11. SPONSOR/MONITOR'S REPORT NUMBER(S)			
12. DISTRIBUTION/AVAILABILITY STATEMENT <b>Approved for public release; distribution unlimited</b>					
13. SUPPLEMENTARY NOTES					
14. ABSTRACT					
15. SUBJECT TERMS					
16. SECURITY CLASSIFICATION OF:			17. LIMITATION OF ABSTRACT	18. NUMBER OF PAGES	19a. NAME OF RESPONSIBLE PERSON
a. REPORT <b>unclassified</b>	b. ABSTRACT <b>unclassified</b>	c. THIS PAGE <b>unclassified</b>	<b>Same as Report (SAR)</b>	<b>17</b>	

**NOTICES**

When U. S. Government drawings, specifications, or other data are used for any purpose other than a definitely related Government procurement operation, the Government thereby incurs no responsibility nor any obligation whatsoever, and the fact that the Government may have formulated, furnished, or in any way supplied the said drawings, specifications, or other data, is not to be regarded by implication or otherwise, or in any manner licensing the holder or any other person or corporation, or conveying any rights or permission to manufacture, use, or sell any patented invention that may in any way be related thereto.

References to named commercial products in this report are not to be considered in any sense as an indorsement of the product by the United States Air Force or the Government.

**APPROVAL STATEMENT**

This report has been reviewed and approved.



KENNETH H. LENERS, CAPT., USAF  
Project Manager  
Directorate of Technology  
Deputy for Operations

Approved for publication:

FOR THE COMMANDER

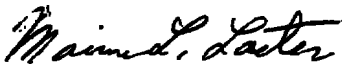

MARION L. LASTER  
Director of Technology  
Deputy for Operations

## FOREWORD

The work reported herein was sponsored by the Arnold Engineering Development Center (AEDC), Directorate of Test Engineering, Research Division (DOTR), under Program Element 65807F. The results were obtained by ARO, Inc., AEDC Division (a Sverdrup Corporation Company), operating contractor for the AEDC, AFSC, Arnold Air Force Station, Tennessee under ARO Project No. P32K-13. This report addresses the Molecular Beam Facility portion of Task 1 of Project P32K-13. The Air Force Project Manager was Captain K. H. Leners.

## CONTENTS

	<u>Page</u>
SUMMARY . . . . .	1
1.0 INTRODUCTION . . . . .	2
2.0 APPARATUS . . . . .	2
2.1 INSTRUMENTATION SURVEY . . . . .	2
2.1.1 Quartz Crystal Microbalance . . . . .	2
2.1.2 Triboelectric Particle Sampler . . . . .	4
2.1.3 Laser Particle Spectrometer . . . . .	4
2.1.4 Infrared Transmission Spectroscopy . . . . .	5
2.1.5 Witness Plate . . . . .	5
2.1.6 Attenuated Total Reflection (ATR) . . . . .	5
2.1.7 Electrostatic Particle Precipitator . . . . .	5
2.1.8 Mie Scattering . . . . .	6
2.2 TEST CHAMBER . . . . .	6
2.3 TEST INSTRUMENTATION . . . . .	6
3.0 TEST DESCRIPTION . . . . .	7
4.0 PROCEDURE AND RESULTS . . . . .	7
5.0 RECOMMENDATIONS . . . . .	8
REFERENCES . . . . .	8

## ILLUSTRATIONS

### Figure

1. Particulate Measuring Instrumentation . . . . .	9
2. Molecular Beam Chamber . . . . .	10
3. Two-Phase Flow Source Molecular Beam Chamber . . . . .	11
4. Two-Phase Generation System . . . . .	12
5. Scanning Electron Microscope Photograph of NaCl Crystals . .	13

## SUMMARY

This reports the status of part of the Plume Contamination technology project which relates to the measurement of particulate contamination in rocket exhaust plumes. A review of existing instruments shows eight types that may have applicability in the unusual environment of high altitude rocket testing.

Hardware has been fabricated which will make it possible to evaluate the particle monitoring instrumentation under realistic conditions in the Research Molecular Beam Chamber. A method of introducing a beam of particles that can be directed toward the measuring instruments has been developed, and partially evaluated. Small particles have been collected and photographed in the scanning electron microscope to check the performance of a particle generating system. Several facets of the two-phase beam system have been addressed, however, the complete system is not yet operational.

## 1.0 INTRODUCTION

Solid rocket motors used for stage separation, stabilization spin-up or orbit transfers are sources of contamination to sensitive spacecraft or satellite surfaces. Solid particulates in the plume range in size from 0.05 to 100  $\mu\text{m}$  in diameter. Future test programs will require detailed information on specific particle size distributions, spacial distributions within the plume, particle chemical composition, particle charge, if any, particle emissivities and particle temperatures in solid rocket motor plumes expanding in vacuum. At the present time it is beyond the state of the art to make these measurements.

This project is a starting point to address the problem of solid particles in gaseous expansions and to consider the experimental approaches which might provide some insight into the particle transport mechanism.

This report includes a review of existing particle sizing and detailing instruments and evaluates their potential for application in the vacuum environment. It also presents a status summary of the progress made in providing a particle loaded gas jet in the AEDC Molecular Beam Chamber.

## 2.0 APPARATUS

### 2.1 INSTRUMENTATION SURVEY

The need for aerosol and small particle detection and measurement has become very important during this period of environmental concern about air pollution. As a result there are many instruments which have been developed for diagnostic tools. They can be classified into two groups; collection devices which require the deposition of particles onto surfaces or into containers and flow-through devices which detect particles as they pass through a selected volume in space. Most instruments are designed to operate at atmospheric pressure, where there are sufficient aerodynamic forces on the small particles to permit them to be manipulated by diverting and channelling the carrier gas flow. Because of this reliance on high gas densities many instruments cannot be considered for application in a vacuum environment.

The following instruments show some potential for application as two-phase flow diagnostics in vacuum.

#### 2.1.1 Quartz Crystal Microbalance

The quartz crystal microbalance (QCM) is a device which measures the mass of material deposited on the surface of a vibrating crystal sensor by determining the change in frequency caused by the additional mass. Such crystals vibrating in the fundamental thickness shear mode have a natural frequency of

$$f = \frac{N}{b} \quad (1)$$

where  $N = 0.166 \text{ MHz}\cdot\text{cm}$  for AT-cut quartz  
 $b = \text{crystal thickness, cm}$

For a small change in thickness then

$$df = - \frac{N}{b^2} db$$

and

$$\frac{df}{f} = - \frac{db}{b} \quad (2)$$

This increase in thickness can be associated with an increase in mass such that

$$dm = \rho A db. \quad (3)$$

where  $\rho$  = density of quartz, 2.65 g/cm<sup>3</sup>  
A = area of vibrating quartz

From Eqs. (1), (2) and (3), then

$$\frac{df}{dm} = - \frac{f^2}{\rho AN}$$

For small changes in mass the differential quantities can be replaced by finite increments and

$$\Delta M = \frac{\rho AN \Delta f}{f^2}$$

For a crystal with a 5 Mz frequency a detectable change of frequency of 1 Hz represents a mass change of  $1.75 \times 10^{-8}$  gms/cm<sup>2</sup>. This mass represents approximately a monolayer of water molecules on the surface or a single 20  $\mu$ m diameter aluminum oxide particle.

Commercial units are available which use the QCM as a sensor for detecting particles. One of these units (Thermo-Systems Inc. Model 3200B) was evaluated under ambient conditions. It was found that particles >5  $\mu$ m did not couple to the crystal. In addition, even the small particles which accumulated on the QCM crystal built up into a loosely packed array which eventually decoupled from the crystal. When this occurred, additional deposits were not recorded by the QCM. It was found that the crystal electrode could be precoated with a thin layer of oil and this made a significant improvement in the coupling of larger particles. Also if the smaller particles were entrained in a gas stream containing condensible vapors then the resulting accumulation coupled very well.

A QCM, based upon a modified Jet Propulsion Laboratories design, has also been used in the AEDC Molecular Beam Chamber. This QCM can be cooled to cryogenic temperatures and used to cryopump certain gaseous species in addition to solid particles. It has been calibrated and shown to be linear when collecting condensed gases. If the crystal surface can adsorb the heat load from the condensing gases then the composite particle and gas cryofrost should couple very well. However, it is possible that in some regions of the plume the gas density will not be sufficient to cement the particles to the crystal's sensing electrode. In these applications it may be necessary to use a thin coating of vacuum grease on the QCM and to operate it warm (i.e., only collect particles and no gases).

### 2.1.2 Triboelectric Particle Sampler

The charge exchange process which occurs when a neutral particle strikes a surface has been utilized to develop a particle sampling instrument. The commercial version marketed by IKOR operates at atmospheric pressure and draws the particle laden gases through tubulation and focuses the particles on a small spherical sensing surface (Ref. 1). The net electric transfer to the detector is amplified and related to particle size by an empirically determined calibration factor.

The triboelectric effect is not well understood although it has been commonly observed. One hypothesis is that when two dissimilar materials come in intimate contact, there is a net transfer of electrons from the one with the lower work function to the one with the higher. Since the net transfer is dependent on the area of contact, then the quantity of charge exchange should be related to particle size. A second hypothesis, however, suggests that a necessary ingredient in the electron transfer is an adsorbed layer of gases on both the particle and the detector. These loosely bound gas molecules are displaced in the collision process and act as charge carriers. The IKOR instrument has been evaluated at AEDC with the following observations.

- (a) At atmospheric pressures, the output signal can be correlated to the total mass loading of particle laden gas flows.
- (b) The unit is extremely sensitive to the condition of the detector surface. Slight contamination by grease or oils significantly affect the sensitivity of the instrument.
- (3) The calibration of the instrument is dependent upon the composition of the particles.

The instrument in its present format is not suitable for detecting particles in rocket plumes. However, there is a possibility that the "triboelectric" effect might be used to construct a particle-sensitive probe which could be used in the low density parts of the two-phase flows.

### 2.1.3 Laser Particle Spectrometer

Schmitt et al. (Ref. 2) describe the development of a prototype open laser cavity instrument for determining small particle sizes and their velocities which could be used in a vacuum environment. In this instrument, developed for NASA, the range of particle sizes was 0.8 to 275 microns and velocities were from 0.2 to 20 m/sec. In principle, the optical geometry is arranged so that the particles flow between the laser cavity mirrors and influence the power output, which is detected and provides a time-dependent signal. The data processing capacity of the system derives particle size from Mie scattering theory for small (1 to 20 microns) particles and from the laser output extinction for larger particles (10 - 100  $\mu\text{m}$ ). The velocity was obtained from the time interval between two peaks in the laser output which vary with time when a particle moves across the optical axis.

Communication with the author of Ref. 2 yielded the information that this equipment was assembled, calibrated with known particles, and then shipped to NASA-Langley Research Center in 1975. Some reservations were expressed in its reliability as an operational instrument for routine measurements. We were not able to contact anyone at Langley who could give us information as to the current status of the equipment.

#### 2.1.4 Infrared Transmission Spectroscopy

Reference 3 describes a method of IR spectroscopy developed for identification of materials adhering to a cryogenically cooled germanium window. Spectra with wavelengths spanning 2.5 to 25  $\mu\text{m}$  were obtained for a number of gases ( $\text{CO}$ ,  $\text{CO}_2$ ,  $\text{NH}_3$ ,  $\text{CH}_4$ , and  $\text{HCl}$ ), and for polystyrene sheet. These demonstrated the feasibility of using the method to identify a material deposited on a transmitting window in the optical path. The arrangement of components is shown schematically in Fig. 1 and consists of an infrared blackbody source, the vacuum chamber windows, mirror, the cooled germanium window and an interferometer.

#### 2.1.5 Witness Plate

The witness plate is a specimen holder for electron microscopy. In the scanning mode, in addition to conventional photographs, the Energy Dispersive X-ray Analysis equipment produces a scan which identifies the location of specific elements on the surface. This method gives at least a qualitative analysis of contaminant particles that will adhere to a solid surface.

#### 2.1.6 Attenuated Total Reflection (ATR)

Reference 4 defines internal reflection spectroscopy as a technique for recording the optical spectrum of material that is in contact with an optically denser transparent medium and then measuring the wavelength dependence of the reflectivity of this interface by introducing light into the denser medium. In practice commercially available ATR plates are used in conjunction with an infrared spectrometer to obtain characteristic spectra of minute quantities of material that has been collected on the surface of the plate. Samples may be in the form of liquids, solutions, fine particles, fibers, a very thin film, and even molecular monolayers. The compatibility with existing spectrographic equipment at AEDC makes this method economical and practical. There is a large library of spectra available (see the bibliography of Ref. 4) for the identification of sampled materials.

#### 2.1.7 Electrostatic Particle Precipitator

The electrostatic particle precipitator is an instrument which charges the particles, either liquid or solid, and collects them by means of a static electric field. The instrument is a Therml-Systems Inc. Model 3100 Electrostatic Aerosol Sampler. The principle of operation as well as characteristic and efficiencies for this instrument are given in Ref. 5. The instrument is designed to operate at atmosphere pressure. A brief description of the basic theory of operation follows.

A carrier gas containing particles is continuously drawn through the instrument by a small external pump. In the charging section the particles are given a positive charge by impacts of positive ions created in a corona discharge. The following section contains the collector (precipitator) which

consists of high positive voltage ( 4200 V) that drives the particles to the collection surface. The precipitating voltage can be either steady or pulsed with the pulsed mode giving the most uniform collection efficiency. This instrument is of value in sampling particles which might be used to seed a two-phase flow gas expansion but does not show promise for vacuum application.

### 2.1.8 Mie Scattering

One method that has been used to measure the size distribution of particles in a two-phase flow is the measurement of the Mie scattering from the particles. One result of the interaction of radiation with particles is the elastic photon-particle scattering process for which the incident wavelength is unchanged by the scattering event. For particles whose dimensions are a significant fraction of the wavelength of the incident radiation the interaction is defined as Mie scattering. For small particles the Mie scattering approaches the Rayleigh molecular scattering theory. The Mie scattering technique is valid over a large range of particles and gas densities. It is only necessary that the Rayleigh scattering from the carrier gas be negligible compared to the Mie scattering from the particles. This is true except for extraordinarily particulate free flows or for extremely high gas density. However, it is necessary that particle shape and optical properties (index of refraction) be known.

Lewis et al. (Ref. 6) have developed a technique for deconvolving the data collected at several scattering angles and using this information to predict a most probable size distribution of particles which would cause such a scattering pattern. While this technique has some limitations it has considerable potential for application to two-phase flows.

## 2.2 TEST CHAMBER

The Molecular Beam research chamber (Fig. 2) is a tank 1 meter in diameter and 2 meters long divided into a source section and a test section by a bulkhead. A molecular beam in the test section results from an expansion of gas from the source that passes through a 6-mm orifice skimmer, which is cryogenically cooled to condense the rest of the gas. The source can be positioned axially by moving it through a 5-cm gate valve and radially by means of a gimbal mount. Vacuum pumping is accomplished by diffusion pumps in both sections and cryogenic surfaces cooled with liquid nitrogen (77K) and gaseous helium (<20K) from a 4-kw refrigerator.

For the present testing a special source was designed to introduce a beam carrying a concentration of solid particles, as shown in Fig. 3. A particle generator attached to the left end provides a flow of gas (such as Ar or N<sub>2</sub>) carrying particles. At the right end a small orifice causes most of the gas to turn 90 deg and a higher concentration of particles to flow along the axis. The orifice size and spacing can be varied to optimize the particulate flow. The electric heating connections to the inner tube may be used to prevent condensation of the carrier gas.

## 2.3 TEST INSTRUMENTATION

For this initial test of the particle beam feasibility, only the quartz crystal microbalance was available. The gaseous helium cooled support, shown in Fig. 1, provided a 20K mounting for the germanium window as well as the QCM. All hardware has been fabricated for the installation of the infrared

transmission spectrum analysis system and the QCM. Materials were purchased and construction was started on a photoelectric detector scanner to be used in collecting light scattering data for subsequent reduction by the deconvolution scheme developed by Lewis et al. (Ref. 6).

### 3.0 TEST DESCRIPTION

The preparations for producing a two-phase flow in the Molecular Beam Chamber were made. However, the manhours available on the composite Plume Contamination project were insufficient to complete the check-out of the system.

### 4.0 PROCEDURE AND RESULTS

Figure 4 illustrates the system developed to generate a gas-particle flow. The carrier gas is supplied by a high pressure bottle of dry gas (Ar or N<sub>2</sub>) which enters a commercial atomizer (Thermo-Systems, Inc. Model 3075) at a pressure of from 30 - 50 psig. The high velocity gas stream in the atomizer induces the flow of a liquid, in this case a salt solution, from a 1-liter reservoir. The liquid is atomized by the gas jet. The atomizer contains a built-in impactor section to eliminate the larger droplets from the gas stream. These impacted droplets as well as the unatomized excess liquid is returned to the reservoir.

The carrier gas along with the smaller droplets of the salt solution proceed along a 1/4-in. tube to the drying tube. The drying tube is a concentric tube packed with a drying agent, Drierite, around the periphery held in place by a cylindrical screen. As the flow passes through the drying tube the droplets evaporate and the water vapor diffuses to the dessicant. Presumably, the droplets are evaporated and only the carrier gas and solid particles exit the dryer.

The electrostatic aerosol sampler described in section 2.1.7 was used to collect a sample of the particles leaving the drying tube. Figure 5 shows a typical photograph taken on the SEM at a magnification of 400. Particle size range was from approximately 0.5  $\mu$  to 50  $\mu$ . This disappointingly wide range of particles and large particle size are still unexplained. The specification on the atomizer indicates a mean diameter of droplets of 0.3  $\mu$  with a standard deviation of less than 1.9. After evaporation the salt crystals should be smaller than this. It may be that the small droplets are coalescing to form larger droplets before entering the dryer.

The NaCl crystals shown in Fig. 5 were collected on an aluminum substrate. A copper substrate was also used, however, these samples were unsatisfactory. It appears that the NaCl reacted with the copper to form a hygroscopic compound which was then dissolved in atmospheric moisture.

A potassium chloride (KCl) solution was also tried. In this case the particles appeared to be powdery and not well defined.

Additional study is necessary in order to optimize the size range of the solid particles, in regard to type solution and dilution. It is also necessary to investigate various types of dryers. A cryogenic cold trap may be needed to remove the moisture from the droplets.

## 5.0 RECOMMENDATIONS

Since the apparatus described in previous sections has been assembled and is ready for checkout, an evaluation program should be started. Particles may be generated by the system described in Section 2.1.7 or by burning small samples of propellant in a combustion chamber. The particles would then enter the vacuum chamber, form a beam, and be detected by one or more of the sampling instruments outlined in Section 2.1. This evaluation in the small chamber will make it possible to select with confidence the instrumentation for subsequent large chamber tests.

## REFERENCES

1. Gruber & Bastress, "Application of the Triboelectric Effect to the Measurement of Airborne Particles," 1973, ISA JSP 6684, pp. 161-169.
2. Schmitt, Boyd, and Linford, "Particulate Contamination Spectrometer," Final Report, NASA contract NAS 9-14171, May 1975.
3. Pipes et al., "Transmission of Infrared Materials and Condensed Gases of Cryogenic Temperatures," AEDC-TR-77-71, Sept. 1977.
4. Harrick, N. J., "Internal Reflection Spectroscopy," Interscience Publishers, John Wiley & Sons. 1967.
5. Liu, et al., "Electrostatic Aerosol Sampler for Light and Electron Microscopy." The Review of Scientific Instruments. Vol. 38, No. 1, 100-102, Jan. 1967.
6. Lewis, J. W. L., Curry, B. P. and Weaver, D. P., "Determination of the Size Distribution Function for Particles in a Hypersonic Flow Field," AEDC-TR-77-101, July 1978.

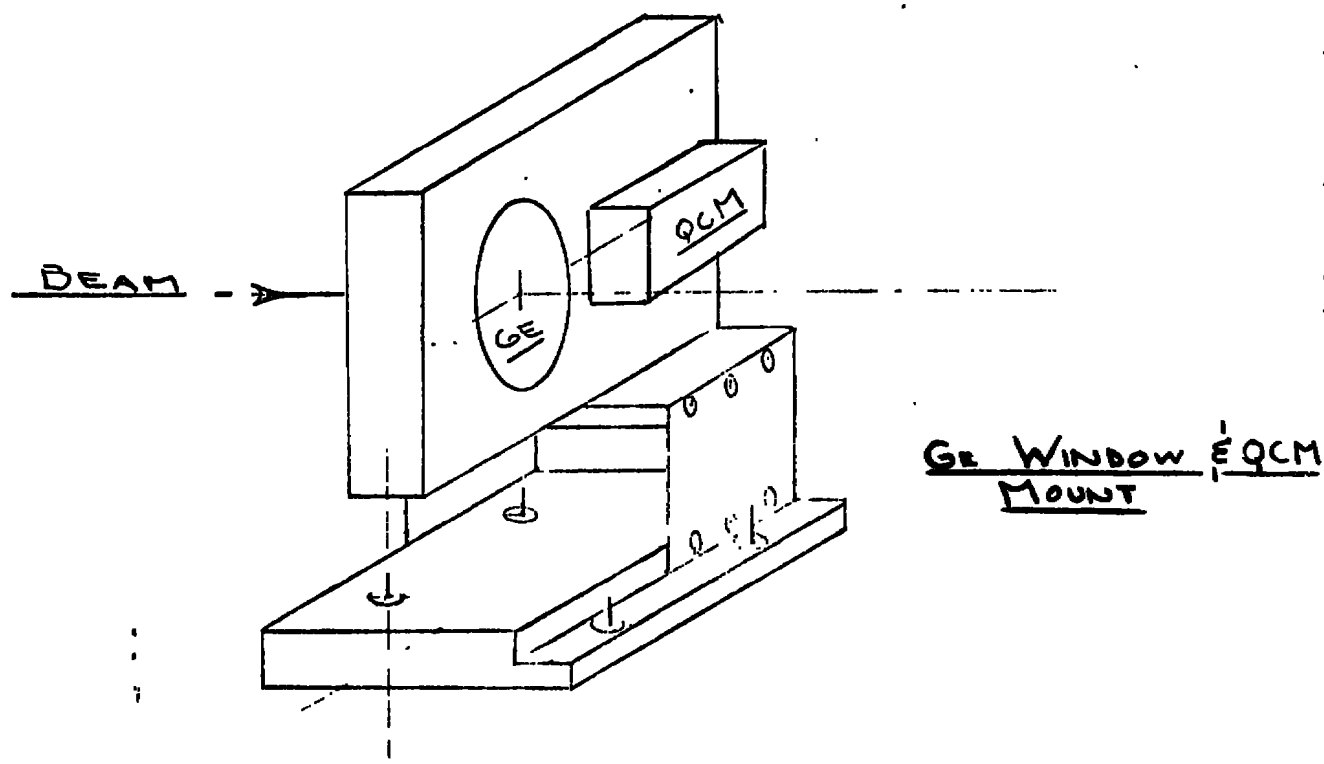
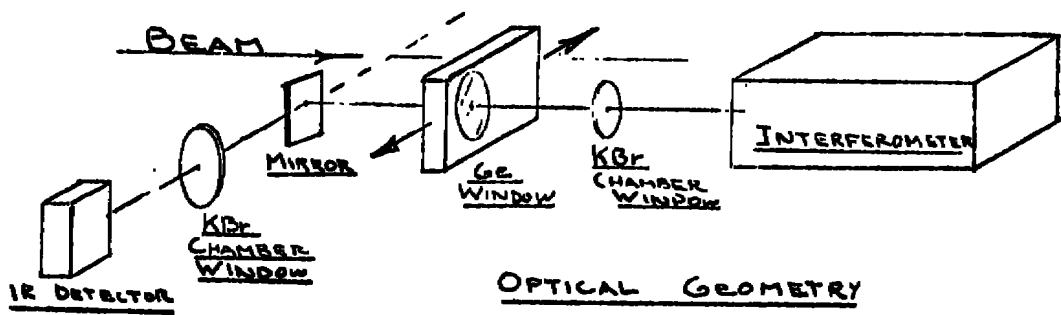

**FIG. 1**  
PARTICULATE MEASURING INSTRUMENTATION

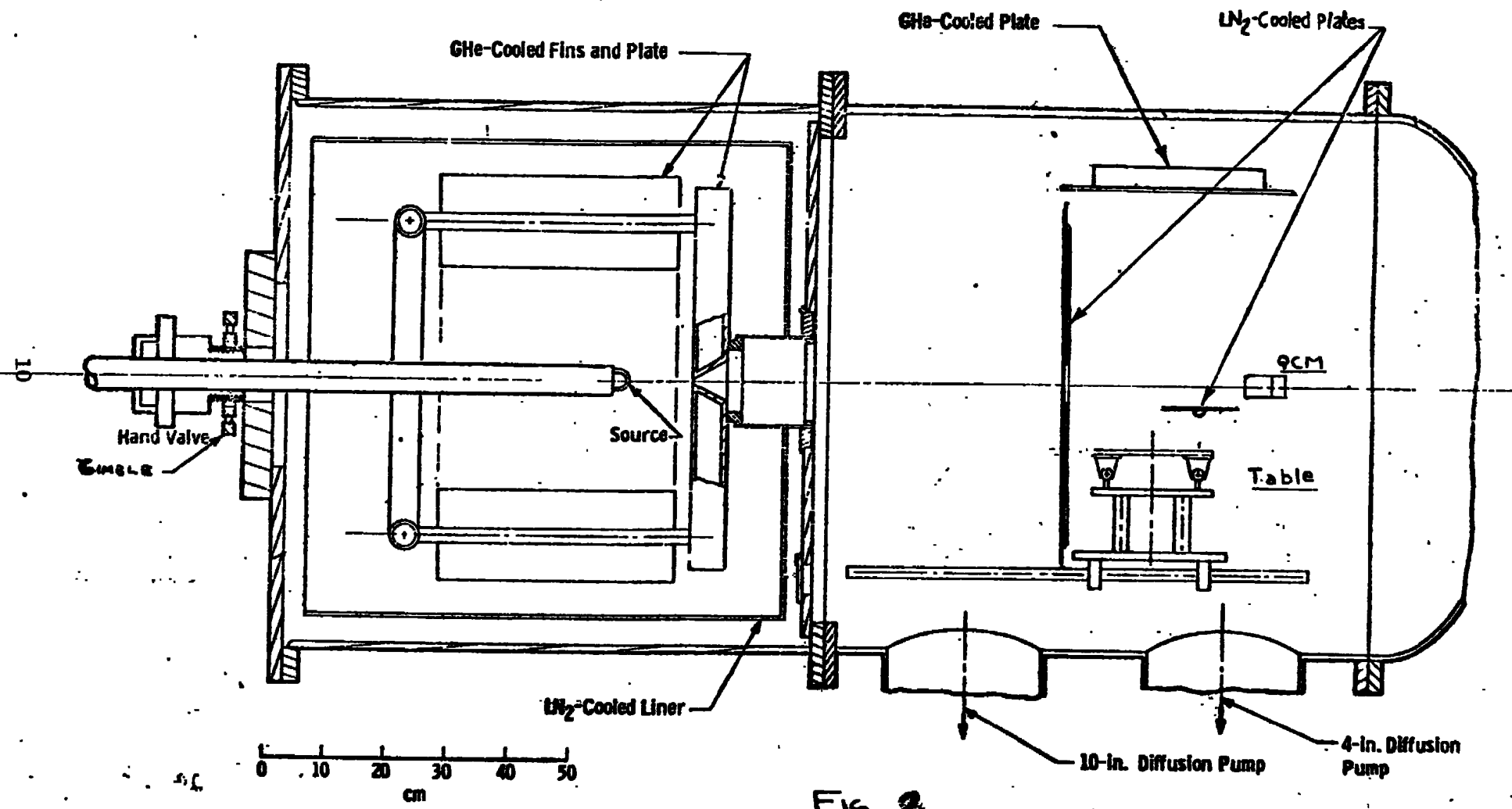

**FIG. 2**  
**MOLECULAR BEAM CHAMBER**

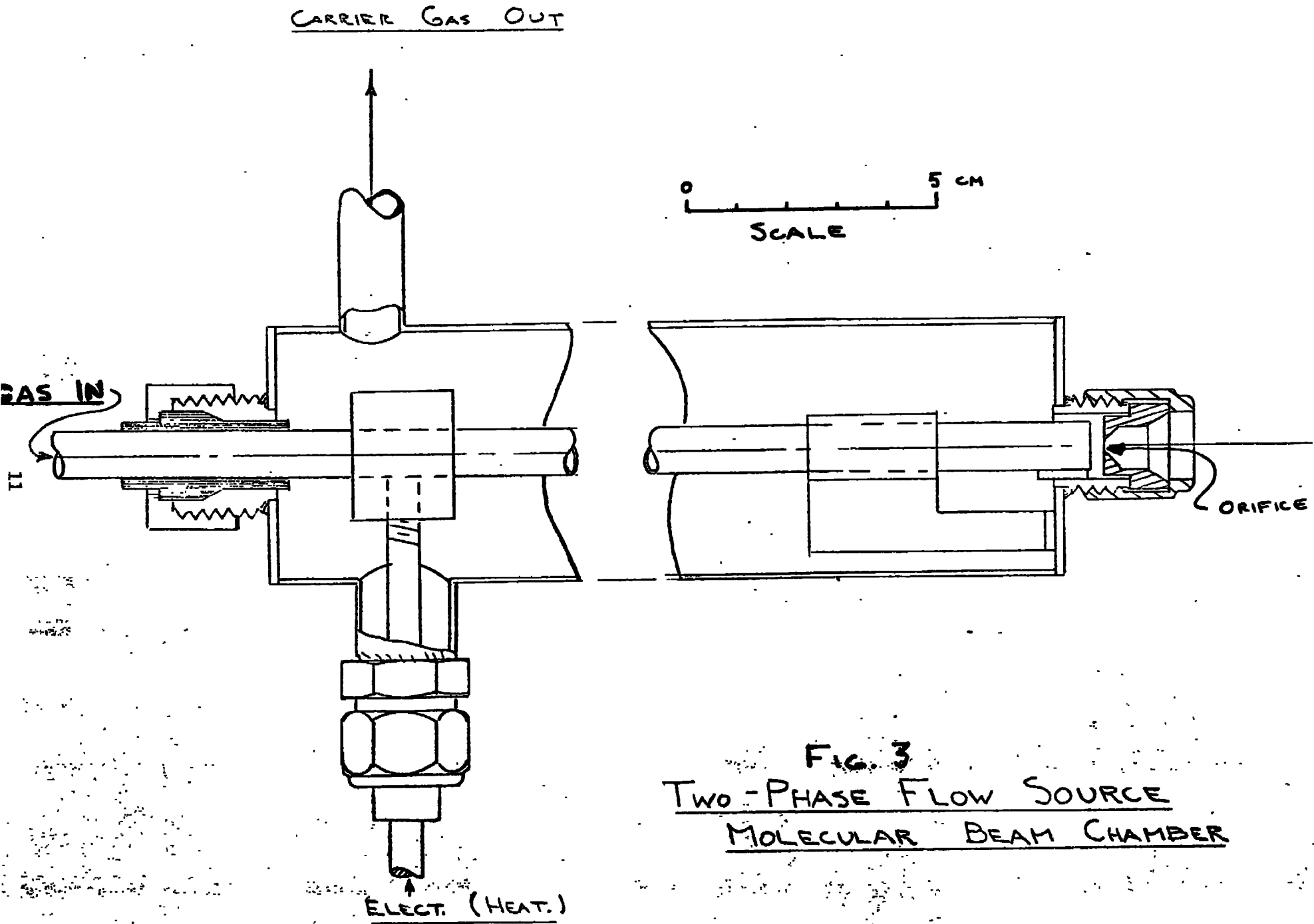

FIG. 3  
TWO-PHASE FLOW SOURCE  
MOLECULAR BEAM CHAMBER

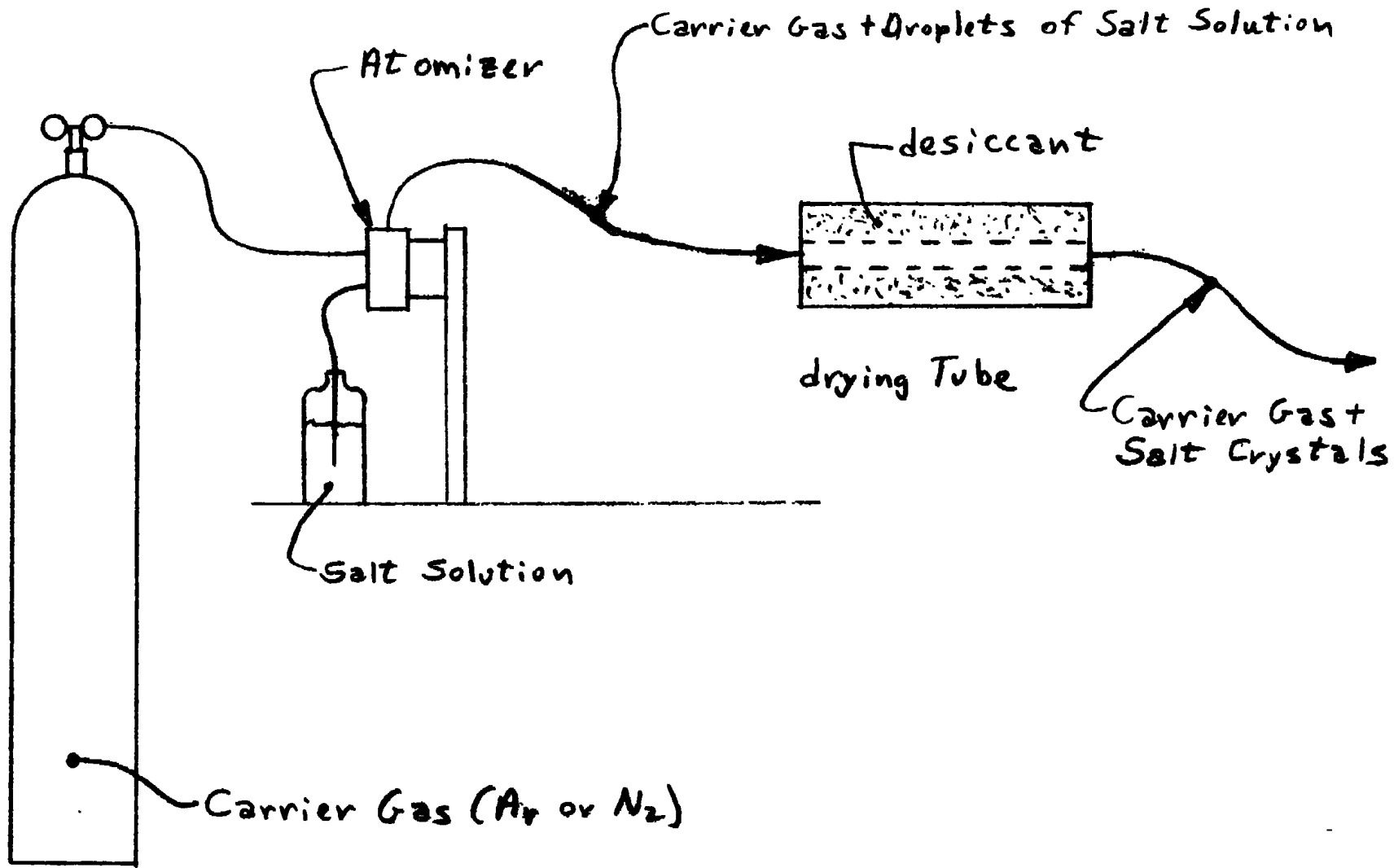

Fig 4. Two-Phase Generation System

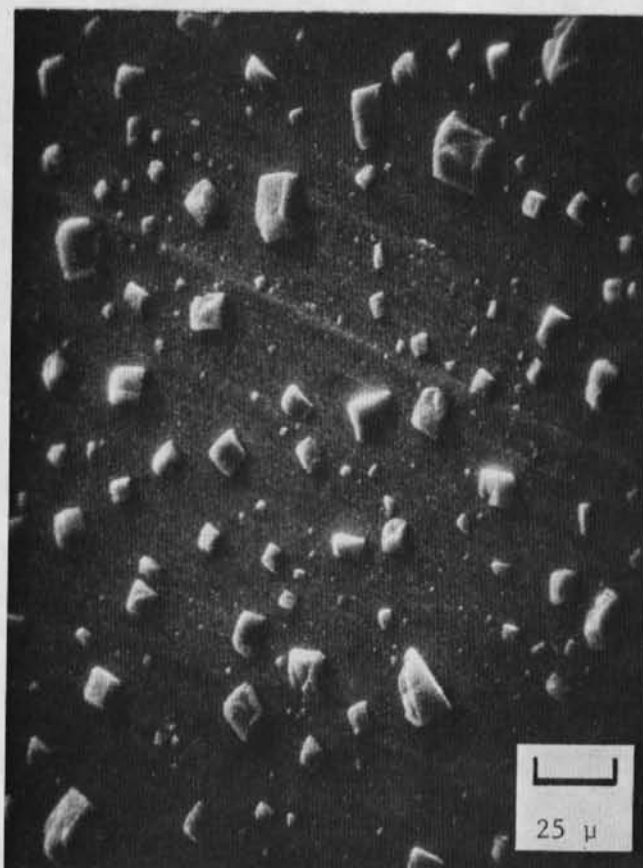

Figure 5. Scanning Electron Microscope  
Photograph of NaCl Crystals (400X)