



*Simulation of Electrochemical Impedance Spectroscopy Response to Coating Flaws,
or
A step towards predicting corrosion*

Stuart Croll, Brian Hinderliter

Department of Coatings and Polymeric Materials
North Dakota State University

Stuart.Croll@ndsu.edu

Report Documentation Page

Form Approved
OMB No. 0704-0188

Public reporting burden for the collection of information is estimated to average 1 hour per response, including the time for reviewing instructions, searching existing data sources, gathering and maintaining the data needed, and completing and reviewing the collection of information. Send comments regarding this burden estimate or any other aspect of this collection of information, including suggestions for reducing this burden, to Washington Headquarters Services, Directorate for Information Operations and Reports, 1215 Jefferson Davis Highway, Suite 1204, Arlington VA 22202-4302. Respondents should be aware that notwithstanding any other provision of law, no person shall be subject to a penalty for failing to comply with a collection of information if it does not display a currently valid OMB control number.

1. REPORT DATE FEB 2010	2. REPORT TYPE	3. DATES COVERED 00-00-2010 to 00-00-2010	
4. TITLE AND SUBTITLE Simulation of Electrochemical Impedance Spectroscopy Response to Coating Flaws,or A step towards predicting corrosion		5a. CONTRACT NUMBER	
		5b. GRANT NUMBER	
		5c. PROGRAM ELEMENT NUMBER	
6. AUTHOR(S)		5d. PROJECT NUMBER	
		5e. TASK NUMBER	
		5f. WORK UNIT NUMBER	
7. PERFORMING ORGANIZATION NAME(S) AND ADDRESS(ES) North Dakota State University,Department of Coatings and Polymeric Materials,PO Box 6050, Dept 2760,Fargo,ND,58108-6050		8. PERFORMING ORGANIZATION REPORT NUMBER	
		10. SPONSOR/MONITOR'S ACRONYM(S)	
9. SPONSORING/MONITORING AGENCY NAME(S) AND ADDRESS(ES)		11. SPONSOR/MONITOR'S REPORT NUMBER(S)	
		12. DISTRIBUTION/AVAILABILITY STATEMENT Approved for public release; distribution unlimited	
13. SUPPLEMENTARY NOTES 2010 U.S. Army Corrosion Summit, Huntsville, AL, 9-11 Feb. U.S. Government or Federal Rights License			
14. ABSTRACT			
15. SUBJECT TERMS			
16. SECURITY CLASSIFICATION OF:			17. LIMITATION OF ABSTRACT Same as Report (SAR)
a. REPORT unclassified	b. ABSTRACT unclassified	c. THIS PAGE unclassified	
19a. NAME OF RESPONSIBLE PERSON			



Overview

- Low frequency electrochemical impedance, EIS, as a metric for corrosion protection by coatings
- Modeling and the decisions made about how to do it.
- Apply same modeling principles as we have used to model appearance, toughness
- Examples



Electrochemical Impedance Spectroscopy as a measure of coating performance

- Measure electrical impedance of a coating across its thickness
 - Between conductive electrolyte on top and metallic substrate
 - Intact coatings have very high impedance (both resistance and capacitance)
 - Low frequency impedance (resistive component) deteriorates upon weathering until it diminishes to the value of a bare metallic substrate
 - Both resistance and capacitance can be calculated with effective media theory based on the concentration of water or ions incorporated into the film



How do water and ions get through a coating?

- Flux/area/(concentration difference) is the permeability coefficient across a film (membrane) (measured at a steady state)
 - Permeability coefficient = diffusion coeff. x solubility coeff.
- So we need to understand diffusion and solubility
- Solubility
 - Tend to find only 2 – 4% water at saturation in an intact coating polymer
 - It is very difficult to find any chlorine or other ions in the cross-section of an intact coating, even after prolonged exposure
 - Therefore not much effect will be seen from dissolved matter – exclude from modeling (today)



How much corrosive material diffuses through a coating?

- Ionic radii
 - Sodium loses an electron, gets smaller
 - Chloride and sulfates gain electrons and get bigger
- Water molecules are small but do we ever find one by itself?
- Diffusion
 - Diffusion coefficient of water into polymers tends to be minute, $\sim 10^{-13}$ m^2/s , takes many hours to saturate (even to 2-4%)
 - Diffusion of NaCl has been measured and is ~ 5 -6 orders of magnitude slower than water [Kloppers, Belluci, Latanision, Brennan, J. Appl. Polym. Sci. 48, 2197 – 2205 (1993) - more recent than Leidheiser or Mayne]
- Can conventional ions get through an intact crosslinked polymer?
 - Not easily: Chloride does not move far in molecular dynamics simulations of crosslinked or thermoplastic polymers [Eslami, Müller-Plathe, J. Chem. Phys. 131, 234904 (2009)]
 - So it is hard to imagine seeing the effects in an EIS test after weathering if the coating is intact

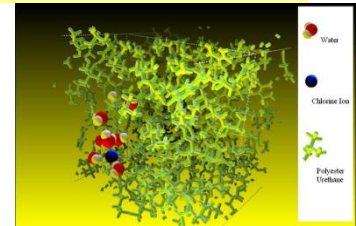



- Therefore we must model coatings that are not intact.
 - Degradation produces a pitted and degraded structure, through which water etc. find it much easier to pass.
 - Changes to becoming a “semi-permeable” membrane at some stage.
- **Intact vs. degraded coatings issue also contributes to why accelerated corrosion tests are not predictive.**

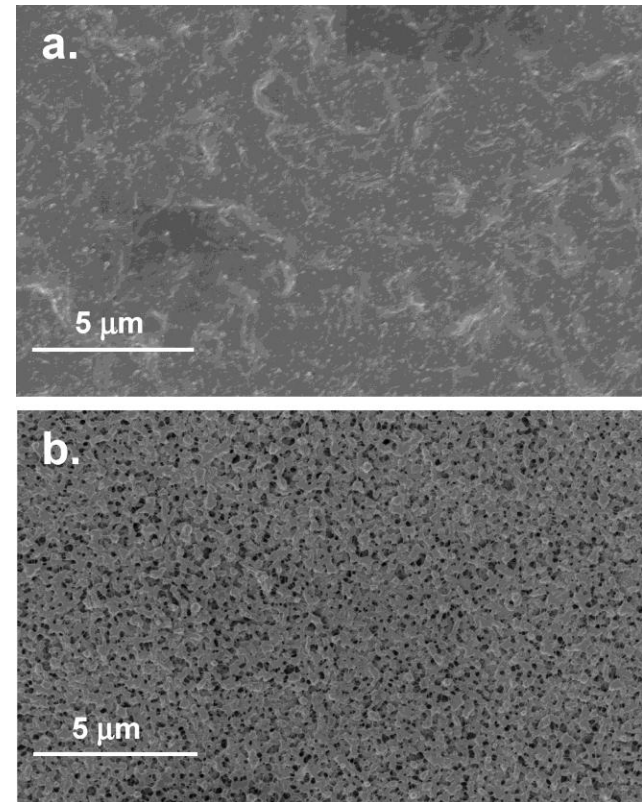

Surface SEM images of films made from 1.4 PEGDGE/chitosan prepolymerization solutions. (b) 2.0 PEGDGE/chitosan prepolymerization solutions. Published in: Bryan D. McCloskey; Hao Ju; Benny D. Freeman; *Ind. Eng. Chem. Res.* DOI: 10.1021/ie901197u Copyright © 2009 American Chemical Society



EIS Testing of weathered Materials

- Periodic evaluation of weathered samples
- When tested, the samples usually start dry, then we put aqueous electrolyte on them
 - Measure the impedance
 - Wait until impedance stabilizes, but water gets in quickly (~ 30 minutes) and we record a reduced impedance as the material is degraded.
- Diffusion of water through intact coatings takes hours
 - Sometimes leads to unstable EIS results
 - Water may get concentrated near substrate depending on cycle
- Model here assumes that water etc. only gets into the degraded, outer, portion of the coating
 - In fact we assume that the saturated (from test electrolyte) outer layer is a dead short and we calculate the impedance of the remaining thickness.



Model the depth of degradation (protection is provided only by intact material)

- Assume wet, porous layer is a short circuit
- Neglected effects (by comparison)
 - Water will diffuse into the coating from its whole perimeter
 - There will be added degradation around perimeter according to Beer's law of photodegradation penetration

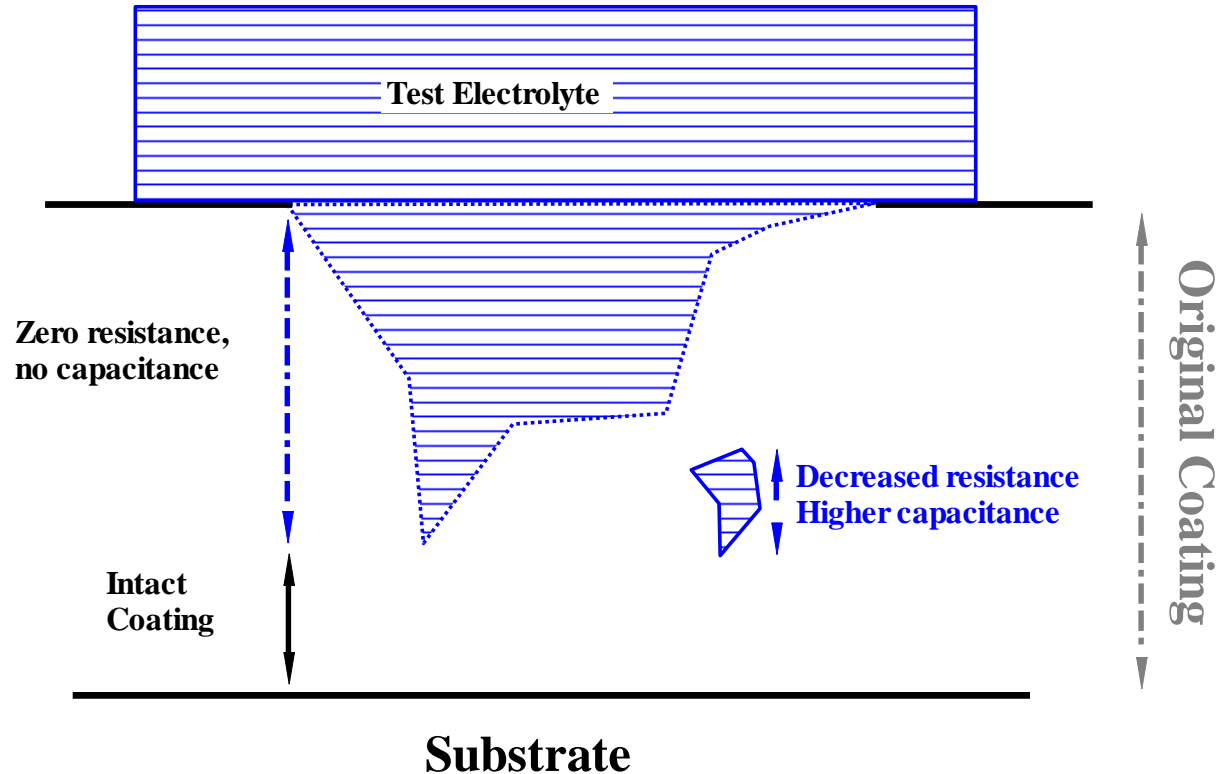



Impedance of One layer of a Coating System

- We focus on calculating the impedance of the intact, interior layer
- Interest ceases stops when corrosion starts, i.e. no inclusion of double layer at corroding metal surface etc.
- No modeling of inhibition
- Assume that a useful model is a resistance and a capacitance in parallel
- Low frequency impedance is dominated by resistive component

$$\text{Impedance} = \frac{1}{\frac{1}{R} + j\omega C}$$

- Assume thickness change due to degradation is only variable in resistance:

$$R = \frac{\rho \cdot \text{thickness}(\text{degradation})}{\text{Area}}$$



Calculating the reduction in intact thickness: Damage Accumulation via Statistics of random processes (physics and maths)

Has been used to predict gloss, color, toughness, etc.

Can be approached via Monte Carlo computer simulations, but we pursue an algebraic form here.

Random repeated events (UV photons, sand etc.) produce a damaged surface that becomes random after many events

- thus we can use a result from Central Limit Theorem (in Normal/Gaussian distributions) for the standard deviation

$$\text{Standard deviation} = (\text{number of events})^{1/2}$$

Similarly, bulk morphology will become randomly damaged if it degrades by an accumulation of repeated events.



Application of Gaussian Statistics to Changes in Surface Roughness

$N(t)$ = Average number of fragments removed at a point on the coating
= Flux of photons x Absorption probability
x Quantum efficiency of removing a length of polymer
x Time (t)

$$= \phi.A.Q.t$$

$$= \text{constant} \times t$$

i.e. average thickness (or mass) decrease, Δd , is linear with exposure time (often good approximation).

If ε = fragment size

$$\Delta d = N(t) \times \varepsilon$$

$$\Delta d = \phi.A.Q.t \times \varepsilon$$

In this case, the rate of degradation is not limited by concentration of any material – ‘zero’ order chemical kinetics, but we can use other kinetics (later)



Thickness diminishes and Surface Roughness increases with exposure.

Roughness

σ = increase given by the standard deviation in the average number of polymer segments removed at a location, after sufficient exposure has occurred to randomize the surface. (ϵ = characteristic physical linear size of fragment)

$$Roughness = \sigma_{RMS} = \epsilon\sqrt{N} = \epsilon\sqrt{\phi A Q \cdot t} = \sqrt{kt}$$

Roughness increases as the square root of exposure time in the case of zero order kinetics.

Mean diminishes linearly with exposure time.

$$\Delta d = \epsilon \cdot N(t)$$

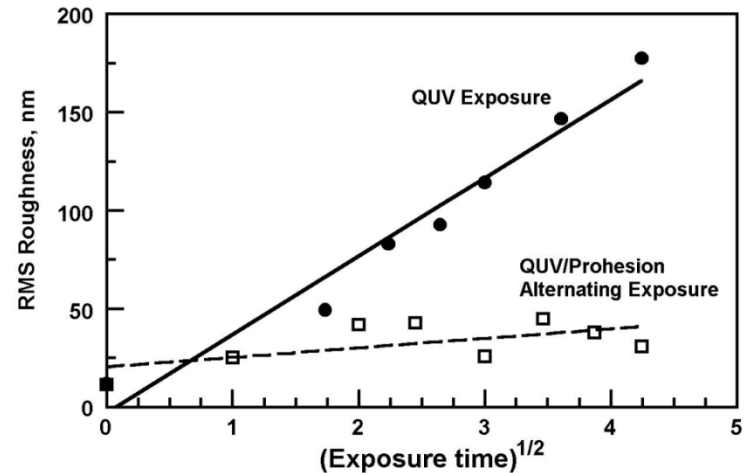



Depth of degradation using “zero order” kinetics From an initially smooth surface

- Gaussian (normal) distributions
- First pore through will be the determining event
 - **Not the average**
- Average thickness diminishes linearly with exposure time,
- But the distribution spreads out as the variance increases
- Calculate the intact thickness by subtracting the deepest degraded thickness from original value

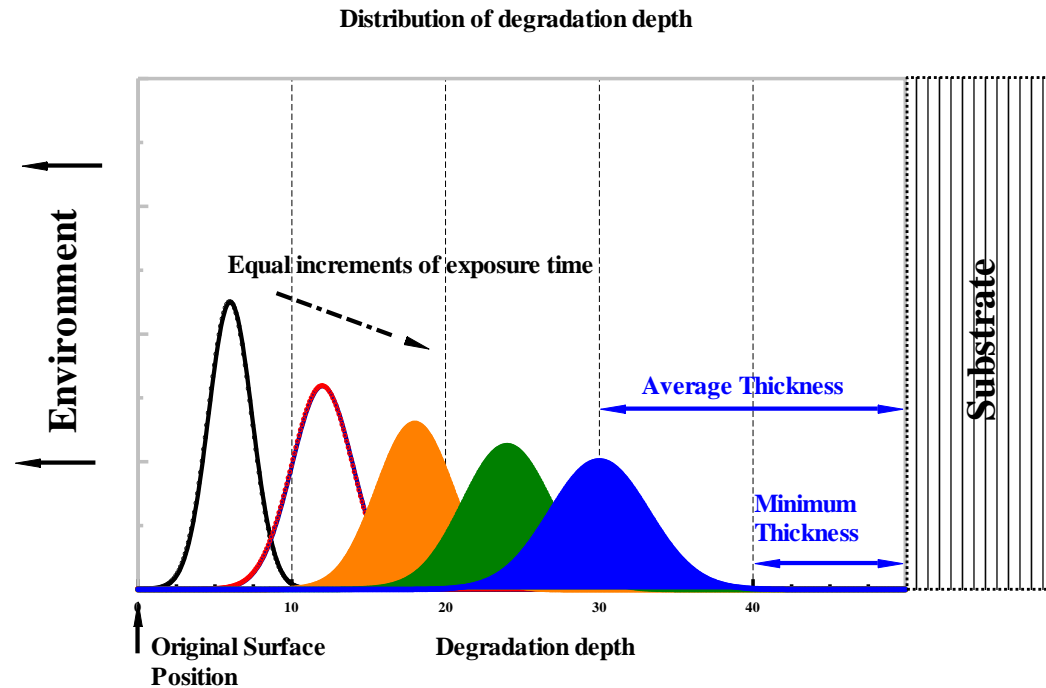

- Effective thickness remaining, depends on
 - **Average change (linear with exposure)**
 - **Std. deviation (square root of time)**



*Options at this stage:
Degradation may be more complicated than
“zero order”*

- From before, reduction in mean thickness” $\Delta d = \varepsilon \cdot N_{\text{Changed}}(t)$
- Degradation Kinetics may be autocatalytic
 - The degradation feeds on itself $\frac{dN(t)}{dt} = \phi \cdot A \cdot Q \cdot N(t)$

The increase in damage, over the starting value

$$N_{\text{Changed}}(t) = N_0 [\exp(\phi A Q \cdot t) - 1]$$

- Or, 1st order
 - the supply of labile material is finite $\frac{dN(t)}{dt} = -\phi \cdot A \cdot Q \cdot N(t)$
 - The increase in damage

$$N_{\text{Changed}}(t) = N_0 [1 - \exp(-\phi A Q \cdot t)]$$



The same options apply to the distribution in degraded thickness

- If there is a pre-existing surface variance (thickness variation), $\sigma_{initial}$, that is also Gaussian

$$\sigma^2(t) = \sigma_{initial}^2 + \Delta\sigma^2(t)$$

- Zero Order (see prior example):

$$\sigma^2(t) = \sigma_{initial}^2 + k.t$$

- Autocatalytic (Malthusian) kinetics:

$$\sigma^2(t) = \sigma_{initial}^2 + \varepsilon^2 N_0 (e^{\phi_{AQ}.t} - 1)$$

- First order kinetics

$$\sigma^2(t) = \sigma_{initial}^2 + \varepsilon^2 N_0 (1 - e^{-\phi_{AQ}.t})$$

- **So the behavior of the average depth of degradation and the greatest depth of penetration can follow other kinetics**



Example of Modeling

- If water gets in via damage due to 'zero order' degradation kinetics
 - there will be term in $(t^{1/2})$ and linear t
 - As the low frequency impedance (resistance) is reduced (data from Gordon Bierwagen)
- Thickness of the film, d , is reduced by:

$$d(t) = d_0 - (At + B\sqrt{t})$$

- Coating life is limited at downturn
- Failure is when water arrives at substrate
 - vs. size of thin spot, plugging

Log_0 (Impedance, ohm.cm², 0.013 Hz)

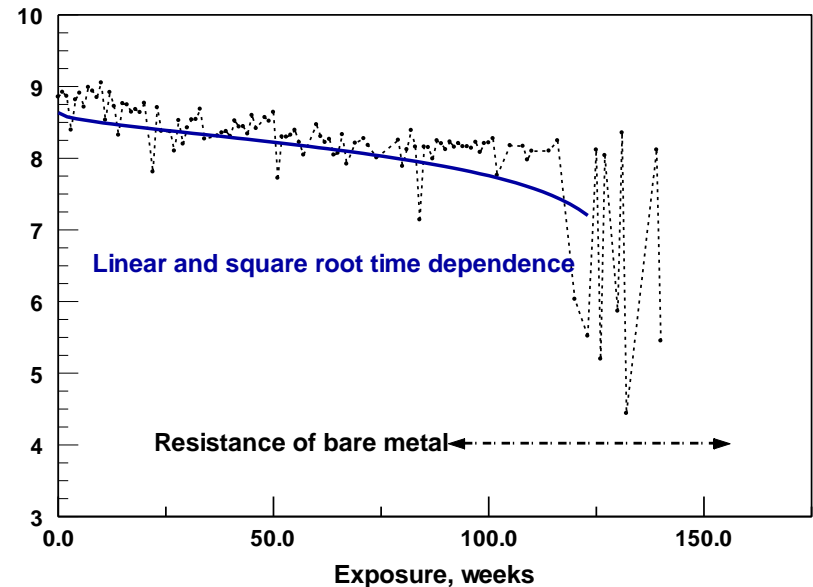

Hinderliter, B. R., S. G. Croll, et al. (2006) *Electrochimica Acta* **51**(21): 4505--4515.

N.B. $t^{1/2}$ looks like a diffusion process



Other aspects & details are possible via this approach

Another example of fit to linear plus square root time.

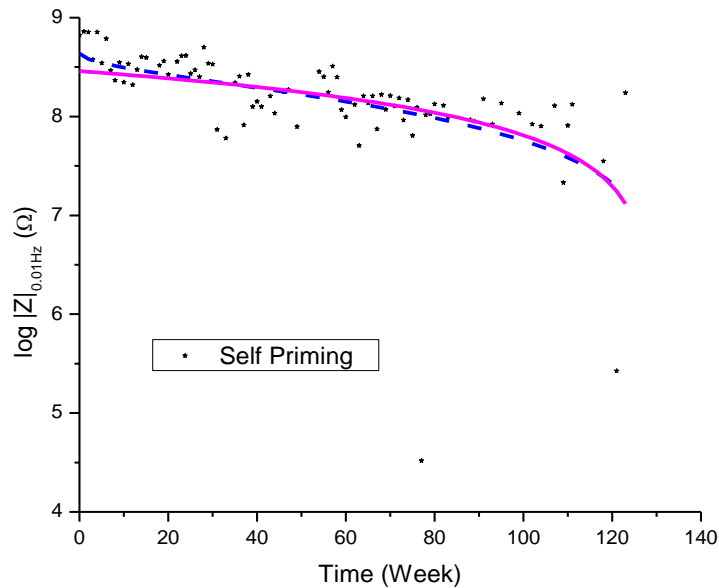

Hinderliter, B. R., S. G. Croll, et al. (2006)
Electrochimica Acta **51**(21): 4505--4515.

- Monte Carlo computer simulations
 - Percolating water channels seem to follow a log-normal arrival time distribution
- Effect of water content in intact layer (changes resistivity and dielectric properties)
 - Via effective media theories
 - Not big effects
- Effect of form of water inclusions
 - O. A. Stafford, B. R. Hinderliter and S. G. Croll, *Electrochimica Acta*, 51(17), 3558-3565 (2006)
- Examine whole frequency spectrum, i.e. include capacitance (actually does not add much)
- Other chemical kinetics
 - Data is not discriminating enough to choose



Summary

- Examine low frequency EIS impedance as an indicator of remaining corrosion protection
- Assumption is that reduction in impedance is due to increase in surface porosity effectively diminishing the intact thickness
 - Aggressive species do not easily get through intact coating during typical testing
- Properties of the intact material do not change
- Simple (zero order) degradation kinetics give dependence of coating resistance that diminishes as exposure time and $(\text{exposure time})^{1/2}$
 - Seems to describe much of the behavior

Future

- Models of corrosion protection (EIS) can be linked to other coating properties
- Provide starting parameters: A , Q , ε and kinetics (chemistry)



Thanks

- Organizers of the Army Corrosion Summit
- Audience
- Colleagues and students
- Supported of the Army Research Laboratory

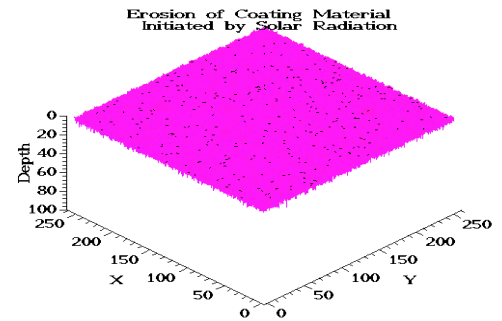

Questions?



Diffusion Coefficient Variations with (intact) Coating Thickness

- Diffusion coefficient and span of diffusion coefficients increase with thickness

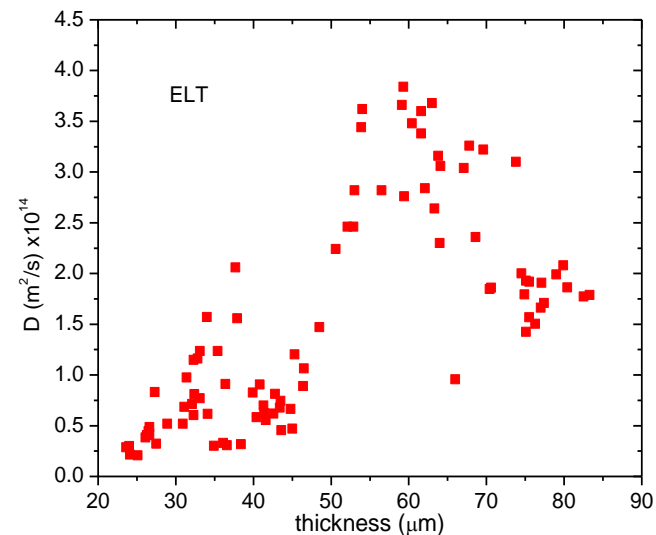
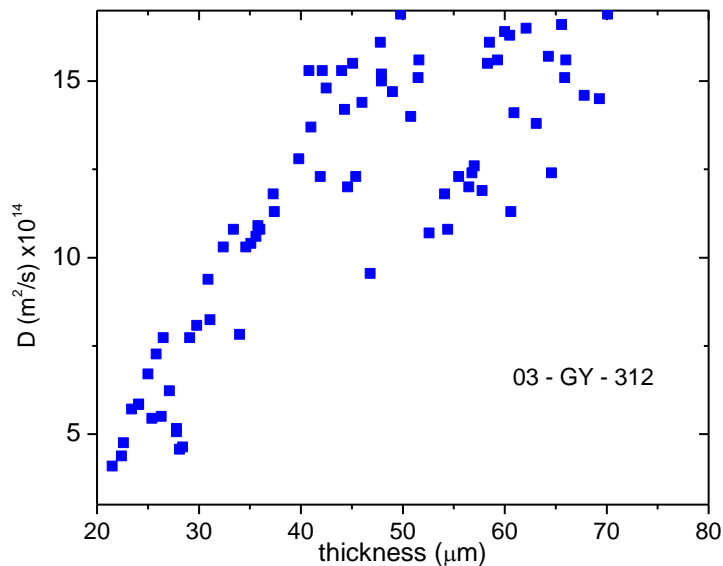
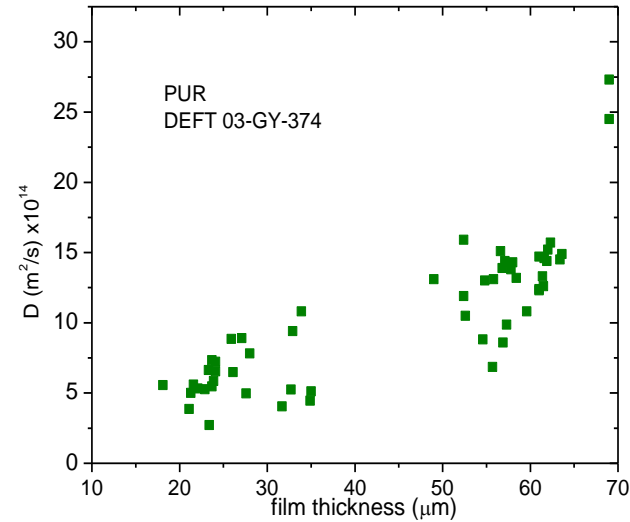



Water Volume Fraction (WVF)

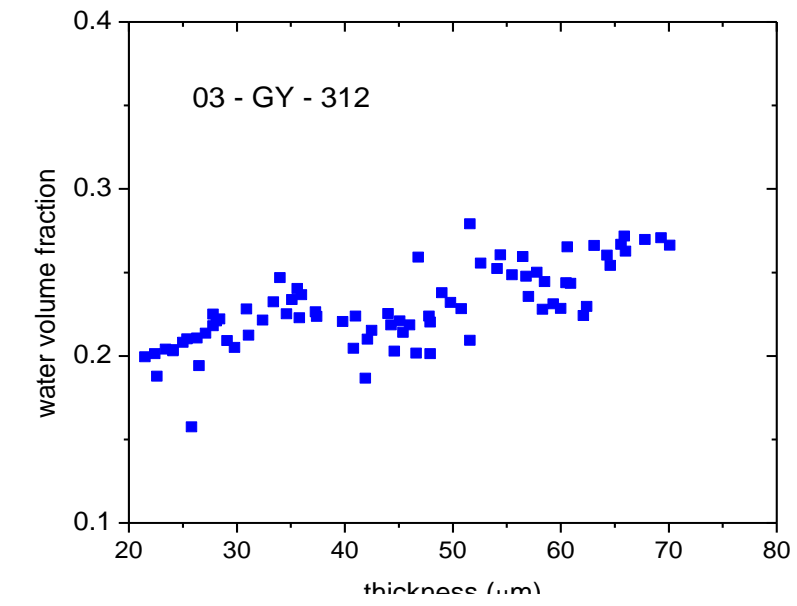
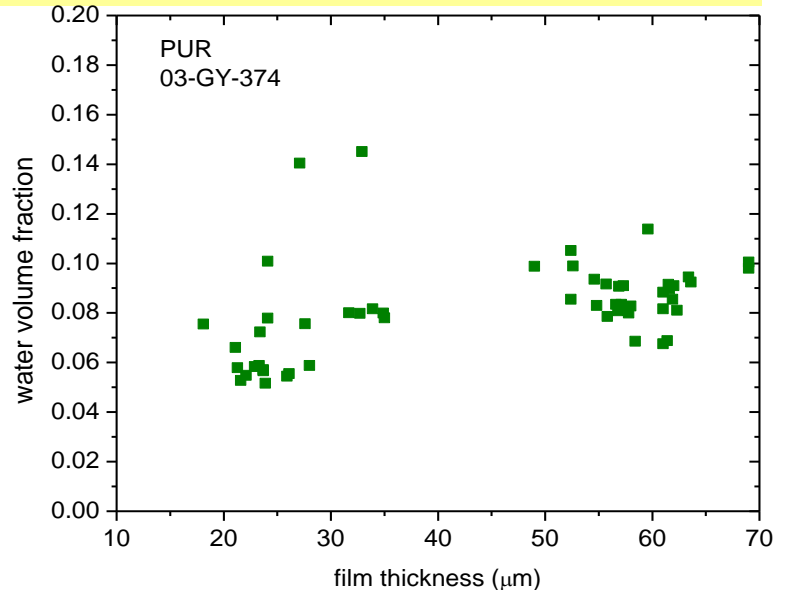
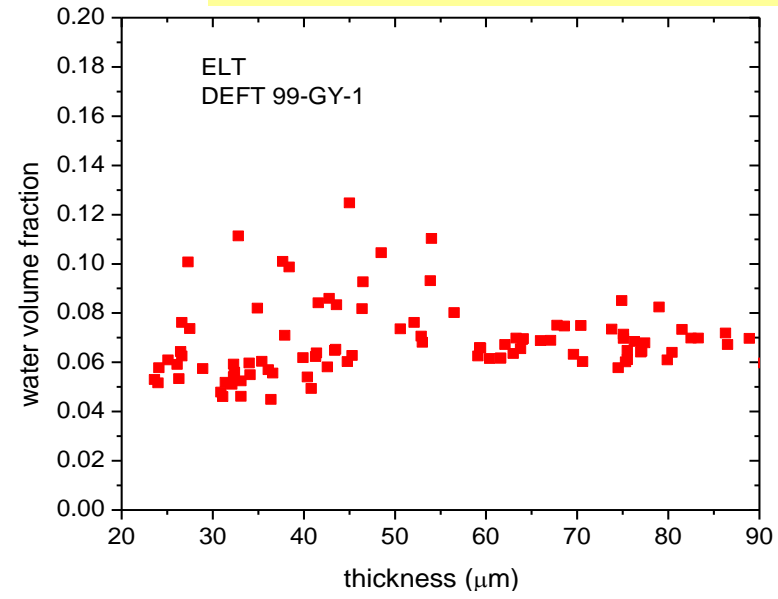

- Topcoat's WVF increase slightly
- Primer's WVF increases



Simulation of EIS with pore structure

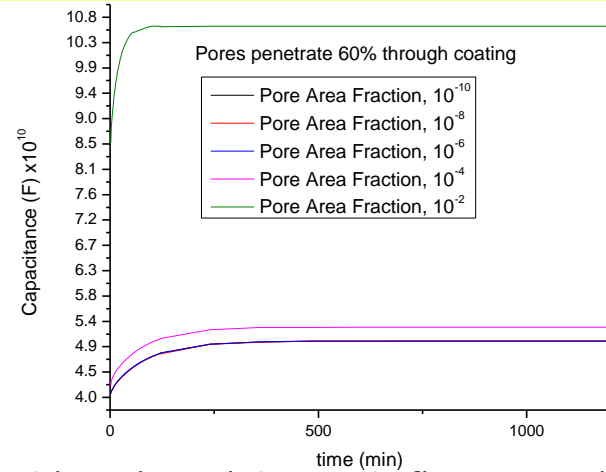
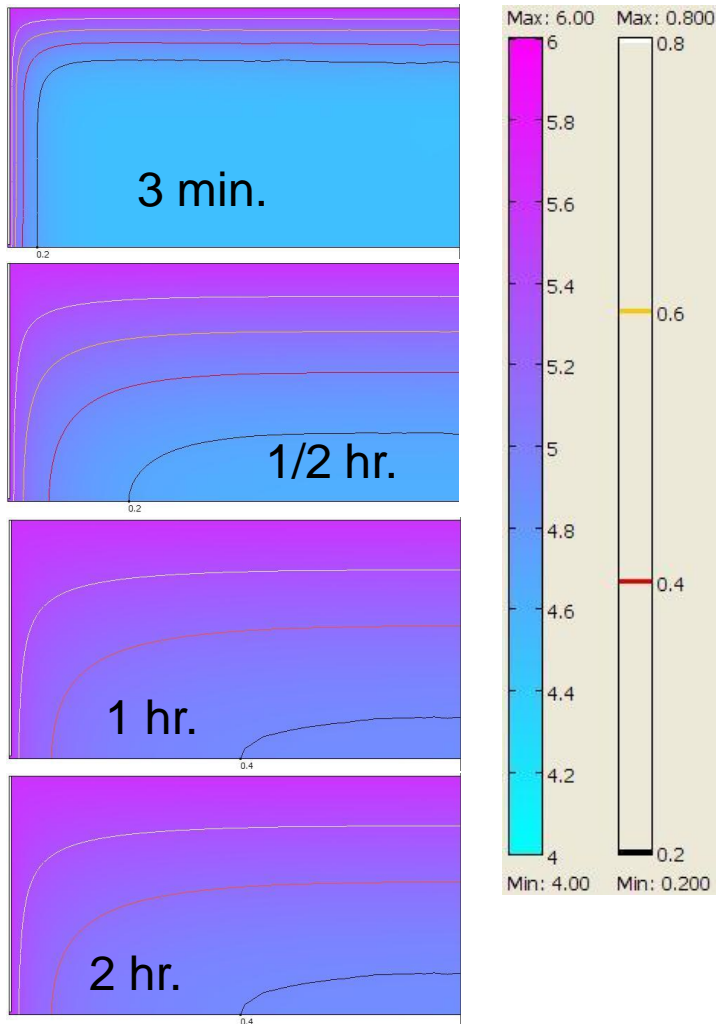

- Simulated SF EIS fit to nonlinear equation just like measurements
- Fitting of simulated materials response gives:
 - Relative dielectric
 - Saturated and dry
 - Diffusion coefficient (effective)
 - Water volume fraction based on Brasher-Kingsbury model

Contour lines indicate fraction of concentration and shading indicates relative dielectric (based on Hartshorn 1905 EMT)



Finite Element Simulations 2D Pore fit to B-K single frequency impedence

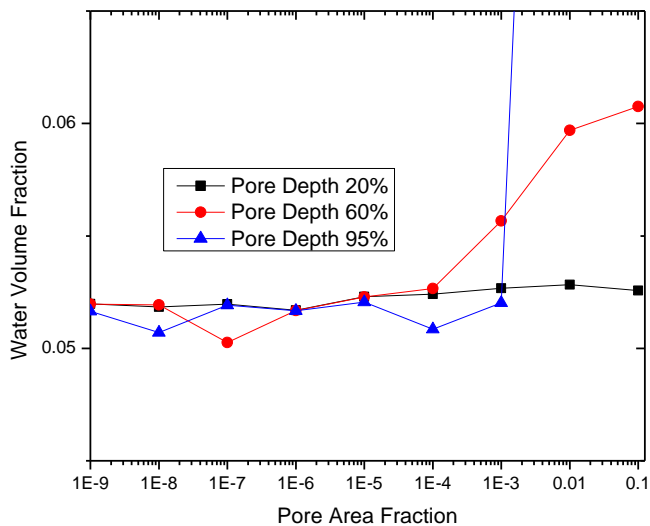
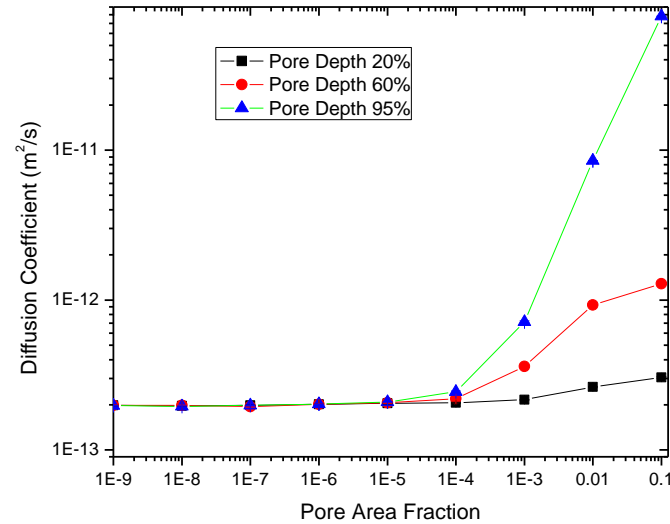
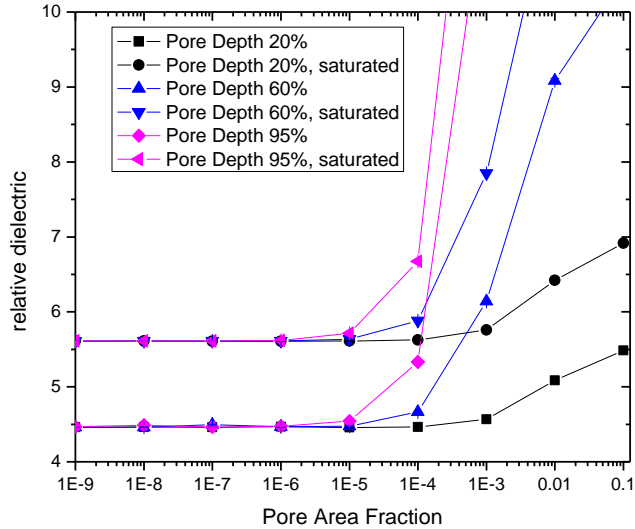

- Both dry and saturated relative dielectric increase at high area fractions
 - Larger increase for deeper pores
- Diffusion coefficient increase as pore density increases

Consistent with measurements but not definitive

1 mm pore in EIS cell has an area fraction of 10^{-9}



EIS Response to composites shapes (Finite Element Geometry for cylindrical water inclusions (3%))

Stafford, O. A., B. R. Hinderliter, et al. (2006). "Electrochemical impedance spectroscopy response of water uptake in organic coatings by finite element methods." *Electrochimica Acta* 52: 1339-1348.

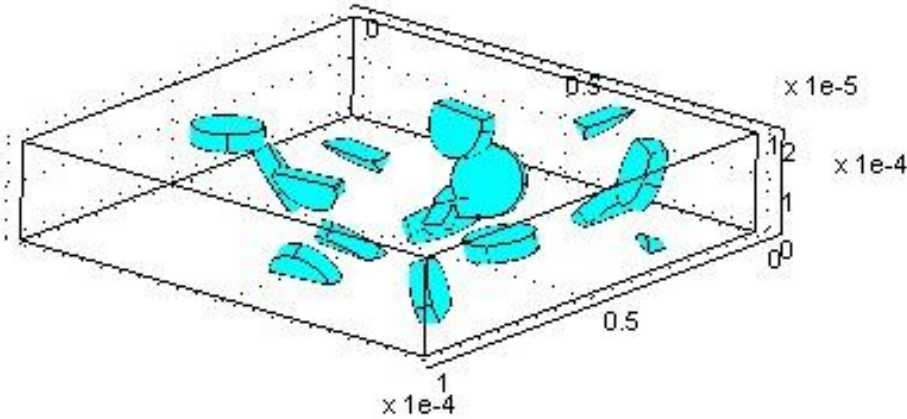

Height/radius=1/2

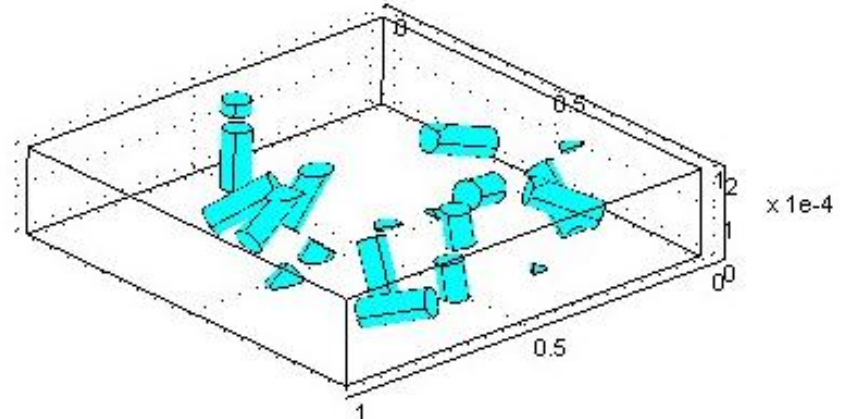

Height/radius=5

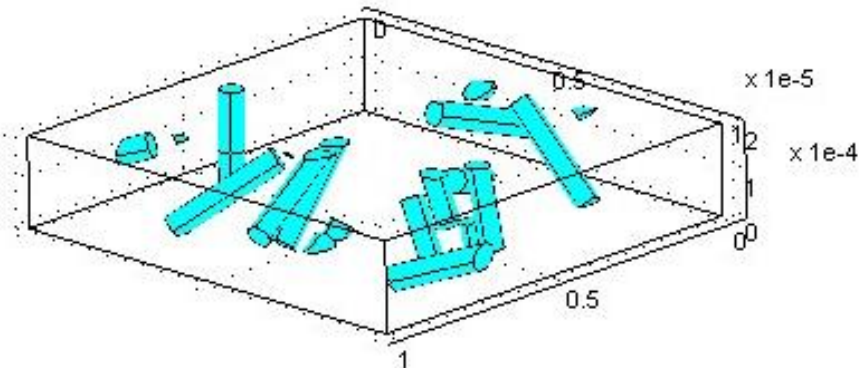

Height/radius=10



Capacitance as a Function of Water Volume Fraction for Spheres and Cylinders

Stafford, O. A., B. R. Hinderliter, et al. (2006). "Electrochemical impedance spectroscopy response of water uptake in organic coatings by finite element methods." *Electrochimica Acta* 52: 1339-1348.

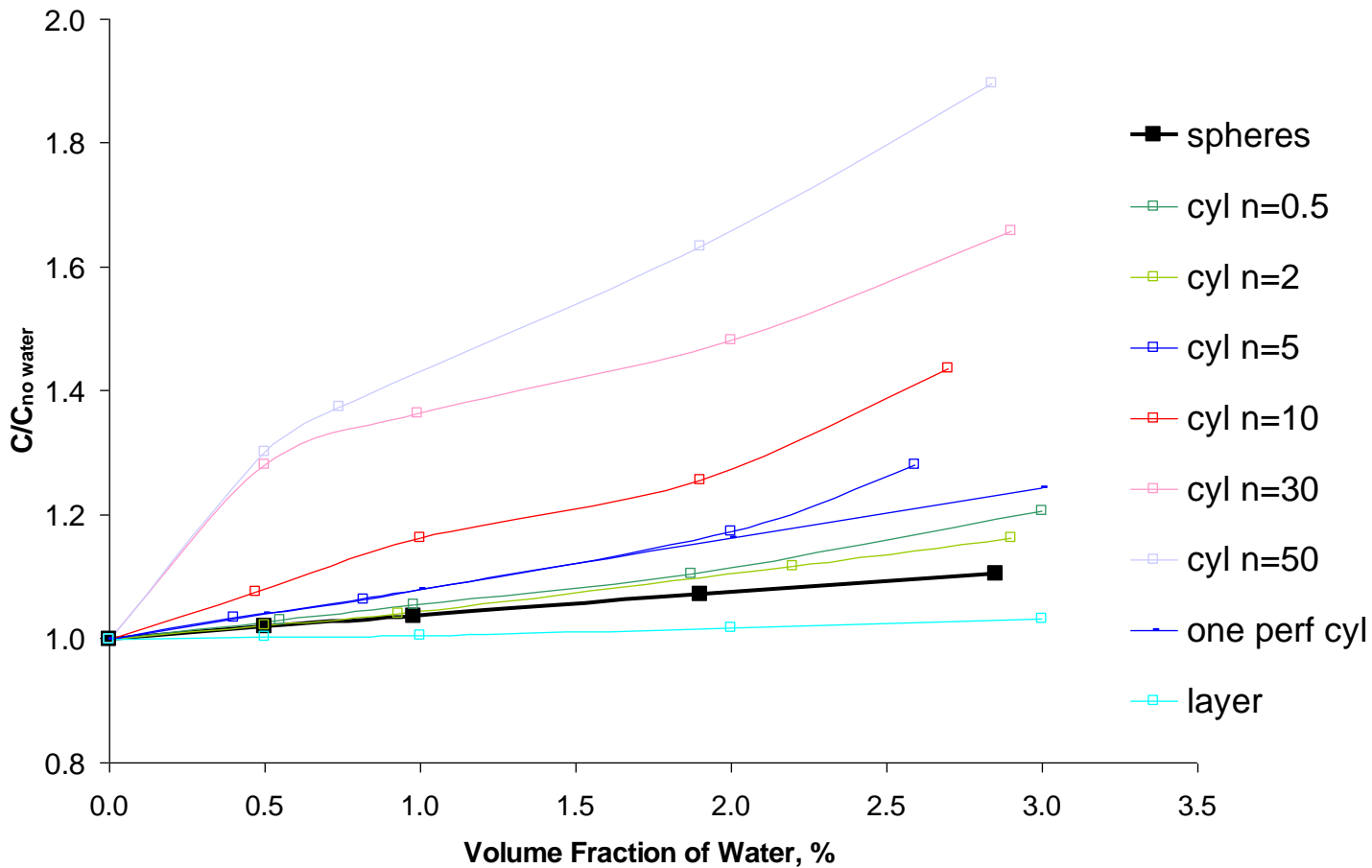



Slope determines lifetime

- Slope depends on
 - Weathering conditions
 - Accelerated
 - Natural weathering
 - Coating conditions (extrinsic properties)
 - Surface treatment/preparation
 - Coating thickness
 - Coating properties (intrinsic properties)
 - Binder crosslink density, water volume fraction at saturation, diffusion coefficient, PVC



Gaussian (Normal) Distribution

- Mean = mode = median = μ
- Variance = square of standard deviation = σ^2 ,

$$f(x) = \frac{1}{\sigma\sqrt{2\pi}} \exp\left[\frac{-(x-\mu)^2}{2\sigma^2}\right]$$

- Central Limit theorem says $\sigma \sim \mu^{1/2}$



Monte Carlo Percolation
The time to percolate water to the substrate from the surface is a log-normal distribution.

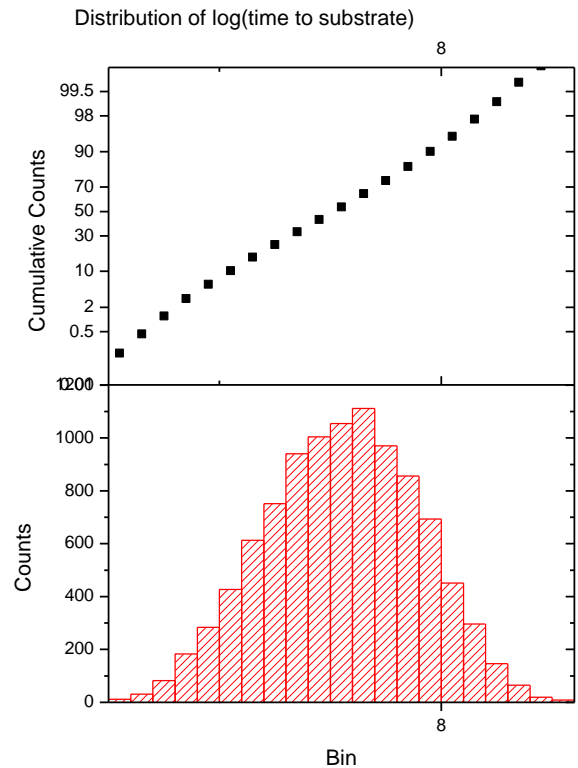



$IZI_{0.012\text{Hz}}$ vs. Time under QUV/Prohesion Exposure (expanded time)

