

Optimization of One-Dimensional Aluminum Foam Armor Model for Pressure Loading

Presenter: John C Goetz

Andrés Tovar

John Renaud

University of Notre Dame

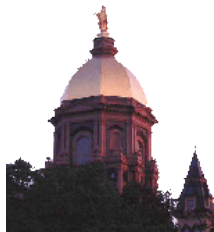

Report Documentation Page

Form Approved
OMB No. 0704-0188

Public reporting burden for the collection of information is estimated to average 1 hour per response, including the time for reviewing instructions, searching existing data sources, gathering and maintaining the data needed, and completing and reviewing the collection of information. Send comments regarding this burden estimate or any other aspect of this collection of information, including suggestions for reducing this burden, to Washington Headquarters Services, Directorate for Information Operations and Reports, 1215 Jefferson Davis Highway, Suite 1204, Arlington VA 22202-4302. Respondents should be aware that notwithstanding any other provision of law, no person shall be subject to a penalty for failing to comply with a collection of information if it does not display a currently valid OMB control number.

1. REPORT DATE 12 APR 2011	2. REPORT TYPE N/A	3. DATES COVERED -	
4. TITLE AND SUBTITLE Optimization of One-Dimensional Aluminum Foam Armor Model for Pressure Loading		5a. CONTRACT NUMBER	
		5b. GRANT NUMBER	
		5c. PROGRAM ELEMENT NUMBER	
6. AUTHOR(S) John C Goetz; Andres Tovar; John Renaud		5d. PROJECT NUMBER	
		5e. TASK NUMBER	
		5f. WORK UNIT NUMBER	
7. PERFORMING ORGANIZATION NAME(S) AND ADDRESS(ES) University of Notre Dame		8. PERFORMING ORGANIZATION REPORT NUMBER	
9. SPONSORING/MONITORING AGENCY NAME(S) AND ADDRESS(ES) US Army RDECOM-TARDEC 6501 E 11 Mile Rd Warren, MI 48397-5000, USA		10. SPONSOR/MONITOR'S ACRONYM(S) TACOM/TARDEC/RDECOM	
		11. SPONSOR/MONITOR'S REPORT NUMBER(S) 21757	
12. DISTRIBUTION/AVAILABILITY STATEMENT Approved for public release, distribution unlimited			
13. SUPPLEMENTARY NOTES Presented at SAE 2011 World Congress April 12-14, 2011 Detroit, Michigan, USA, The original document contains color images.			
14. ABSTRACT			
15. SUBJECT TERMS			
16. SECURITY CLASSIFICATION OF:			17. LIMITATION OF ABSTRACT SAR
a. REPORT unclassified	b. ABSTRACT unclassified	c. THIS PAGE unclassified	
			18. NUMBER OF PAGES 16
19a. NAME OF RESPONSIBLE PERSON			

Break down

Optimization of One-Dimensional Aluminum Foam Armor Model for Pressure Loading

- Pressure loading
 - i.e. blast
- Aluminum Foam
 - i.e. cellular materials
- Optimization
 - Minimizing acceleration

The Blast Problem

- Rapid expansion of a shockwave with high T and P emanating from a blast source
- Impact from a shock *deforms* and accelerates the receiving structure

How to mitigate the effects of the blast?

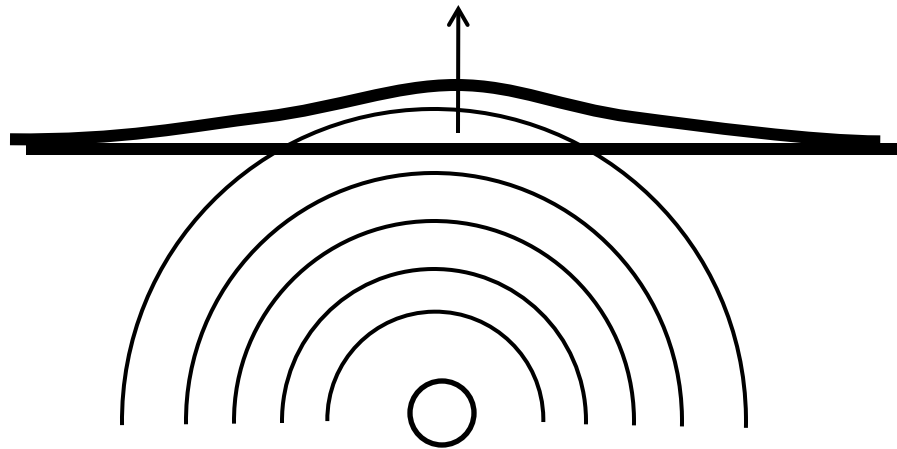

3

Cellular materials

- Material that contains a repeated base cell structure
 - Foams
 - Honeycombs
- Characterized by
 - Low density
 - Cannot support tensile loadings
- Near ideal compressive deformation behavior:
 - Transmit minimal load
 - Absorb significant energy

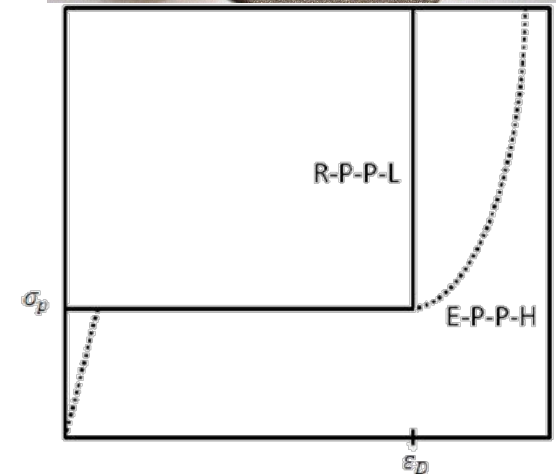
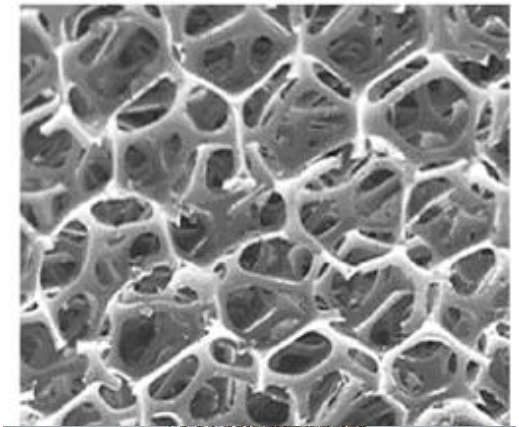

Problem Setup

- Objective:
 - To protect a mass from the acceleration effects of a pressure loading
- Modeling:
 - Pressure represented as a square pulse
 - Foam material properties are modeled as a function of relative density
 - System is modeled as series of springs and masses
 - System is unconstrained (inertial BCs)

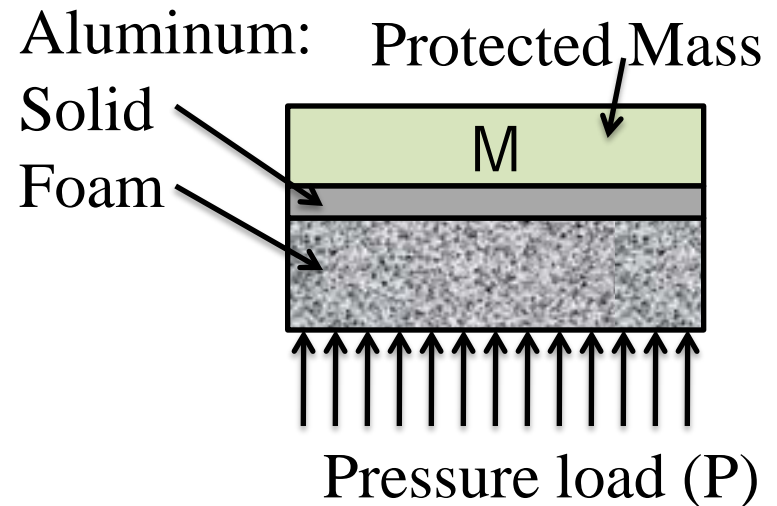
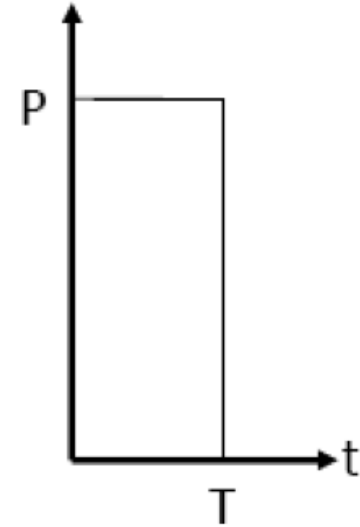

Material Properties

- According to Hanssen (2002), material parameters can be described with calibration functions
- Stress as a function of strain is then a function of the parameters

$$\left\{ \sigma_p, \alpha, \frac{1}{\beta}, \gamma \right\} = C_0 + C_1 \left(\frac{\rho_f}{\rho_0} \right)^n$$

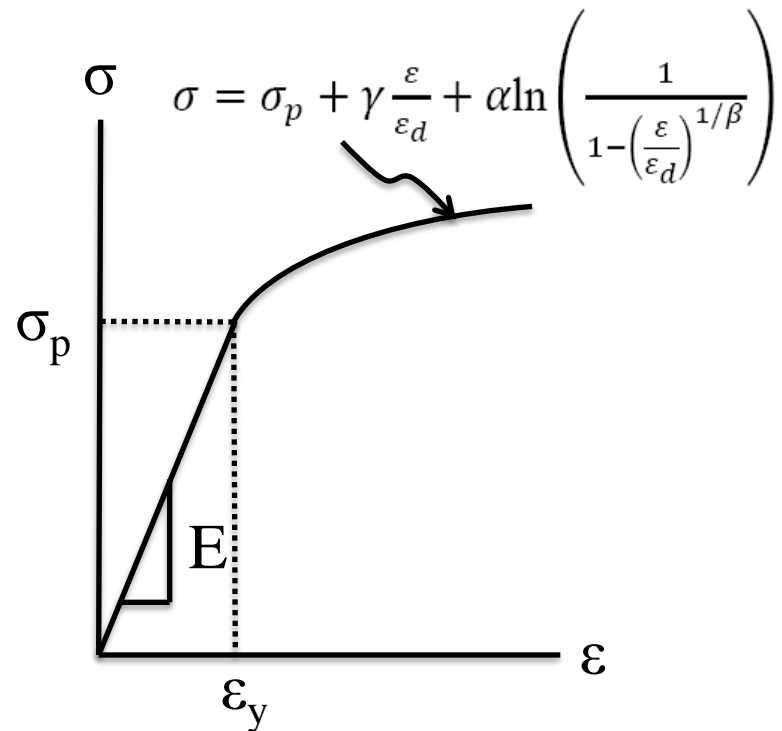

System Model

- System model has an elastic-plastic spring based on the material properties of the given element joining each mass
- There are $n+1$ masses
 - n for the armor
 - 1 for the protected mass

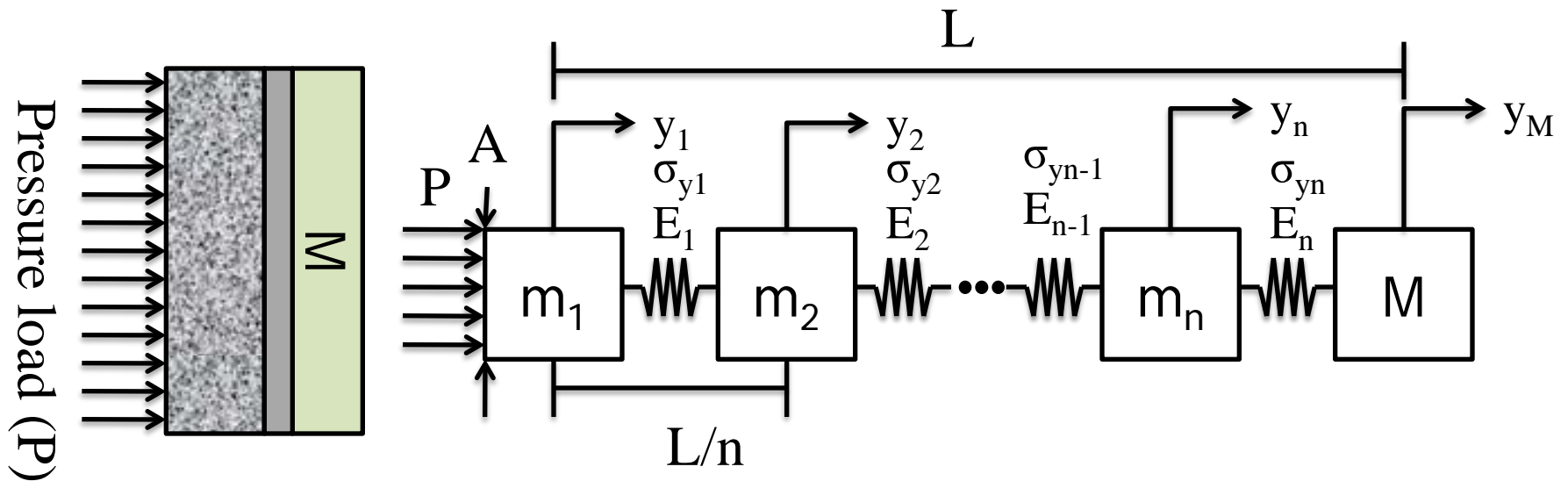

Equations of Motion

$$m_i \ddot{y}_i = F_L - F_R = A(\sigma_L - \sigma_R)$$

$$m_i = \frac{\rho_i L}{\rho_0 n} A \rho_0 = x_i \frac{L}{n} A \rho_0 \quad \omega^2 = \frac{T^2 \sigma_{y0}}{\rho_0 L^2} \quad \dot{y}_i = \frac{\ddot{u}_i L}{T^2}$$

$$\ddot{u}_i = \frac{AT^2 \sigma_{y0} n}{x_i A \rho_0 L^2} \left(\frac{\sigma_{i-1}}{\sigma_{y0}} - \frac{\sigma_i}{\sigma_{y0}} \right) = \omega^2 \frac{n}{x_i} \left(\frac{\sigma_{i-1}}{\sigma_{y0}} - \frac{\sigma_i}{\sigma_{y0}} \right)$$

$$KE_{ND} = \frac{x_i}{2n\omega^2} \dot{u}^2 \quad IE_{ND} = \frac{1}{n} \int_{\varepsilon_0}^{\varepsilon_f} \frac{\sigma_i}{\sigma_{y0}} d\varepsilon \quad W_{ND}^{ext} = u_1 \frac{P}{\sigma_{y0}}$$

Model Parameters/Convergence

Total system length: $L=.1\text{m}$

Pressure Pulse duration: $T=150\mu\text{s}$

Protected Mass: $M=100\text{kg}$

Parameter	C_0	C_1	n
σ_p	0 (MPa)	720 (MPa)	2.33
γ	0 (MPa)	42 (MPa)	1.42
α	0 (MPa)	251 (MPa)	1
$1/\beta$.1	15.7	3

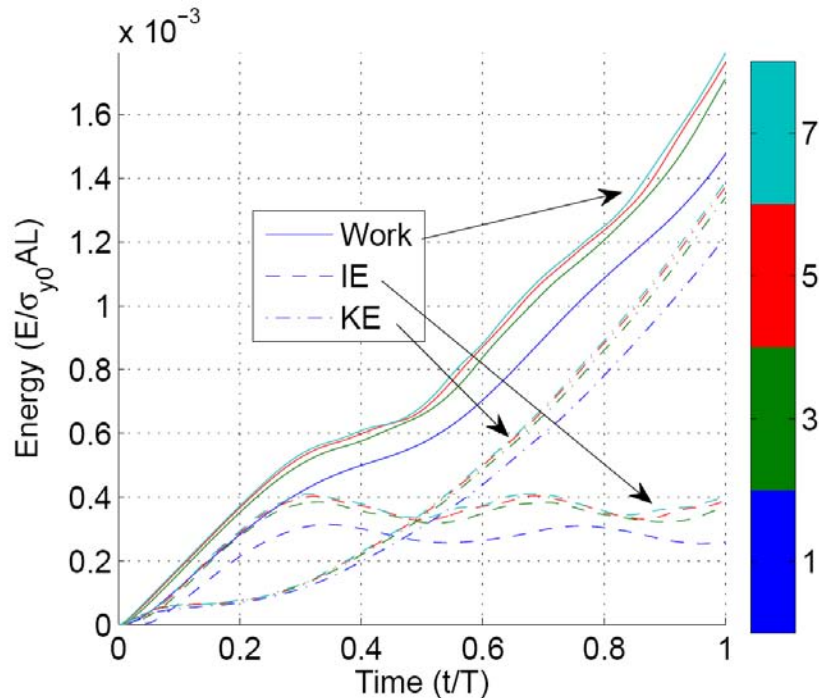

$$\sigma_{y0} = 276 \text{ MPa}$$

$$E_0 = 68.9 \text{ GPa}$$

$$\rho_0 = 2700 \frac{\text{kg}}{\text{m}^3}$$

LOAD CASE 1: $P = 0.1\sigma_{y0}$

$$\min_x \{ \max \ddot{u}_M \}$$

s.t. $x_L \leq x_i \leq x_U$

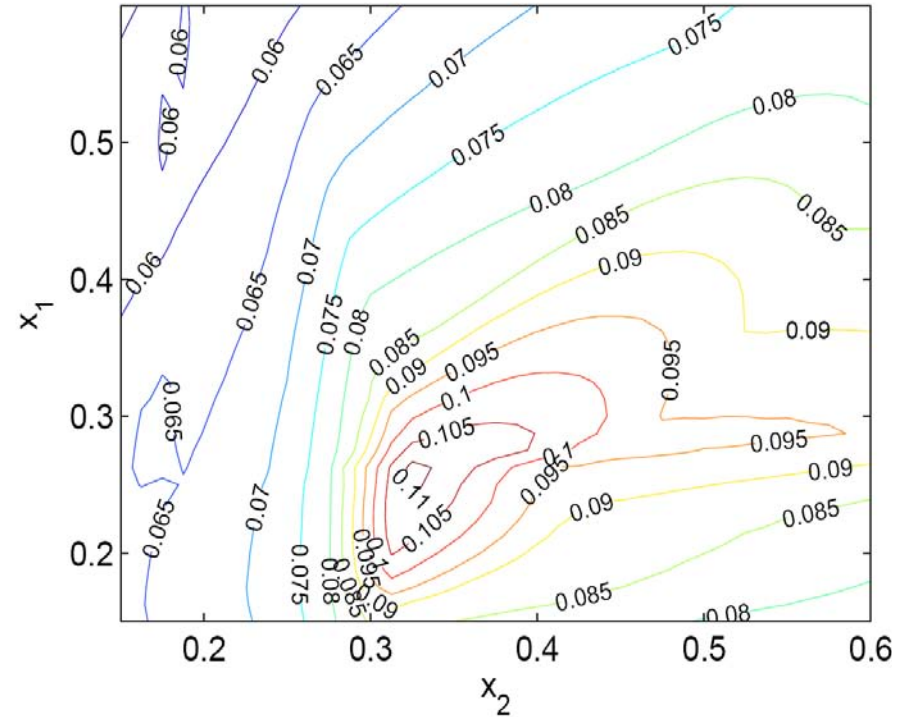
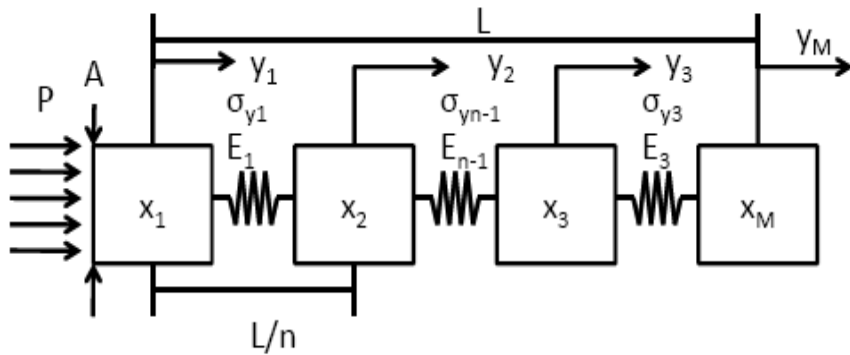

	x_1	x_2	
Graphical Solution:	0.6	0.15	0.05423

Higher Load Values

LOAD CASE 2: $P = 0.2\sigma_{y0}$

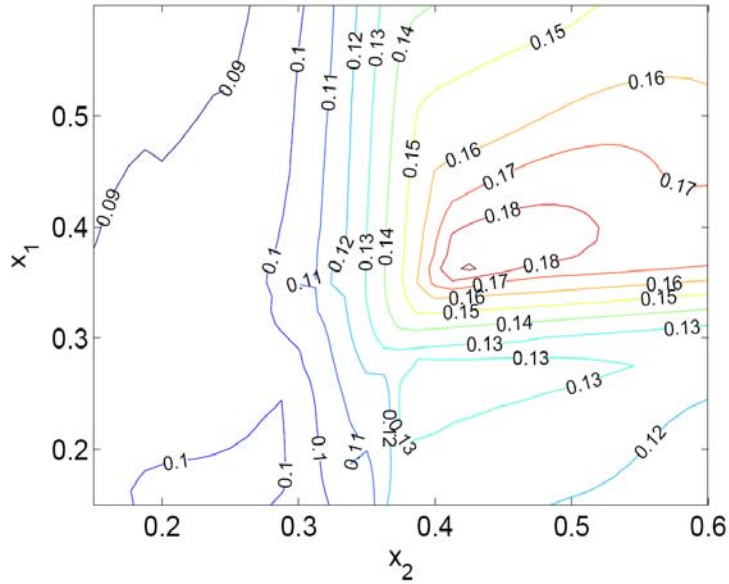

$x_1 = 0.60$ and $x_2 = 0.15$

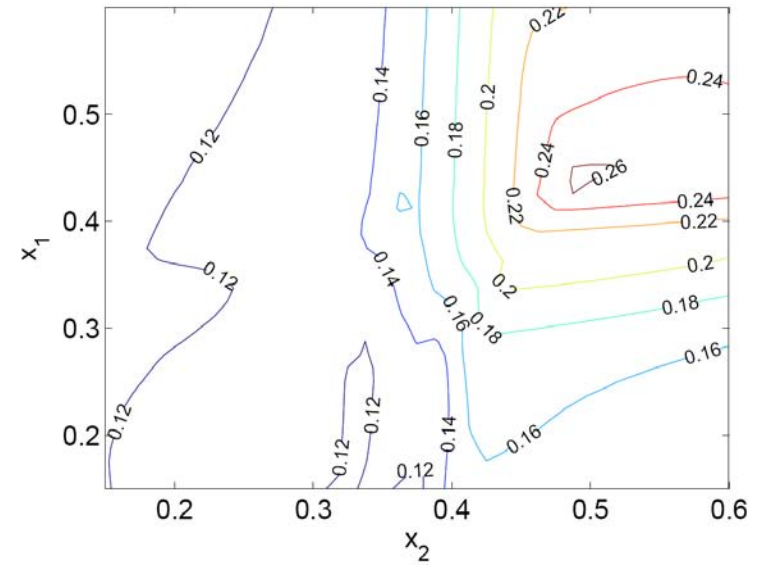

Solution space of 2DV acceleration minnimax problem with $P = 0.3\sigma_{y0}$

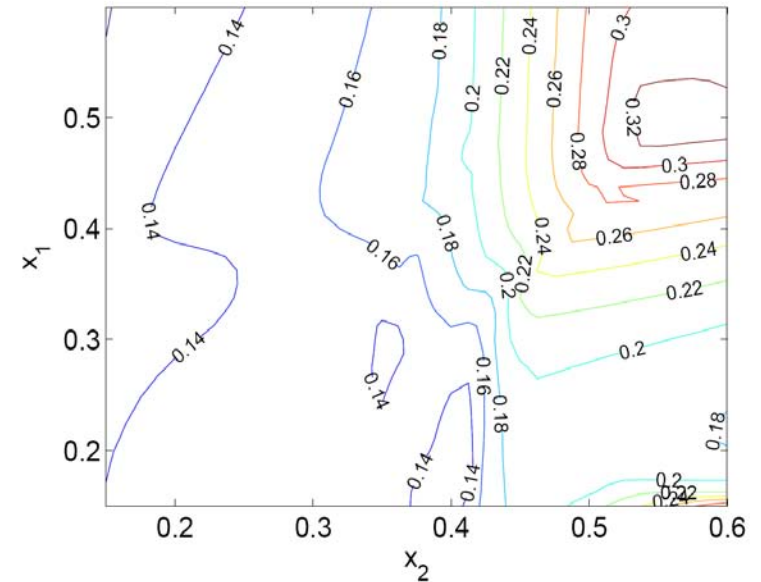

Solution space of 2DV acceleration minnimax problem with $P = 0.4\sigma_{y0}$

System Response Comparison

Relative densities of comparison systems

System->	1	2	3
x_1	0.6	1	0.375
x_2	0.15	1	0.375
x_3	1	1	1

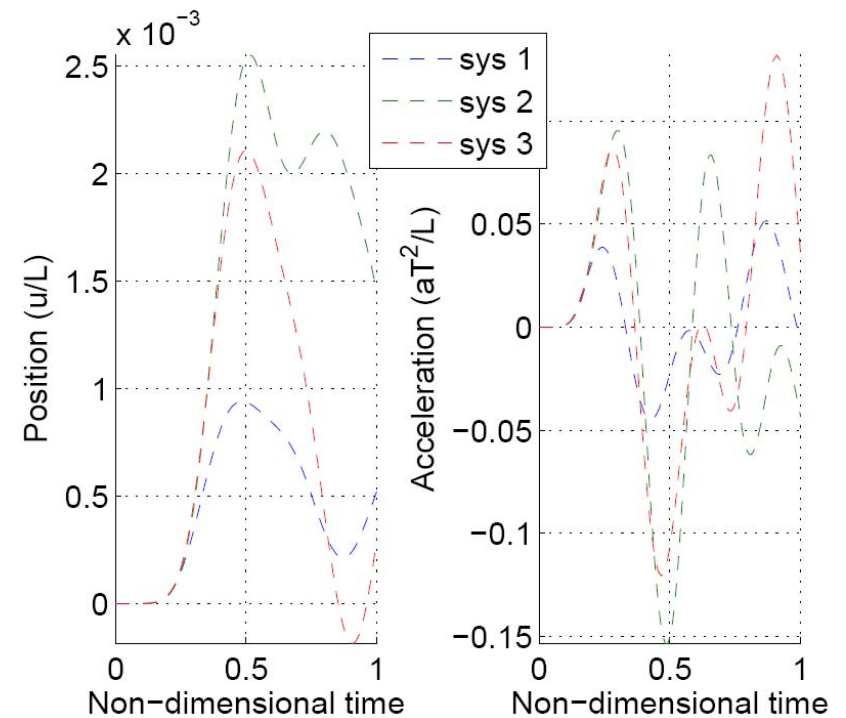
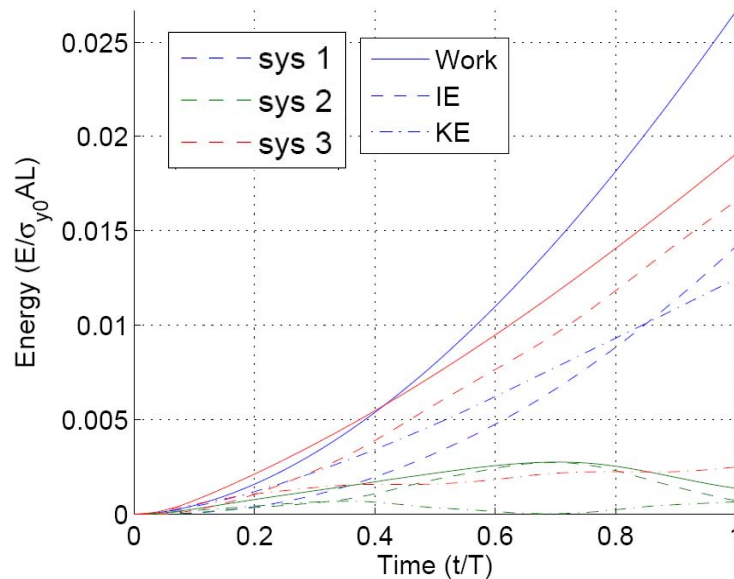
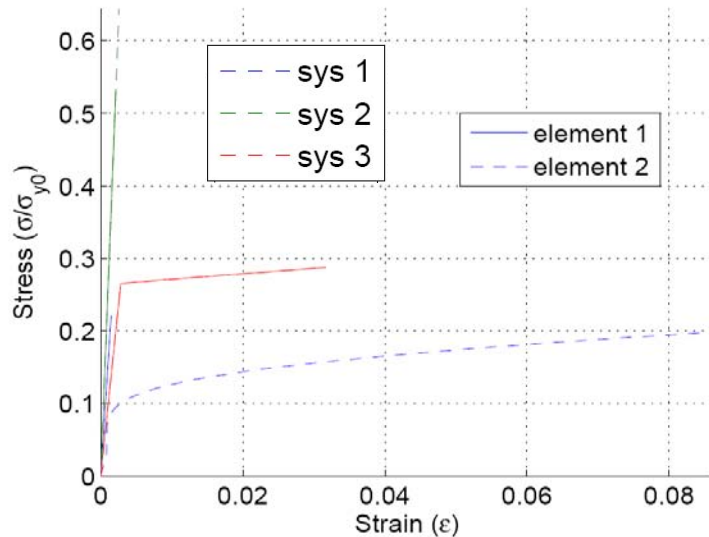

Conclusions

- Found optimal design for 2 elements of foam
 - $x_1 = .6$ (highest density)
 - $x_1 = .15$ (lowest density)
- Observed that
 - More energy absorbed does not necessarily give the best result
 - Less work done by the blast can be worse than more work
 - Having more system kinetic energy

QUESTIONS?



This material is based upon work supported by the U.S. Army TACOM Life Cycle Command under Contract No. W56HZV-08-C-0236, through a subcontract with Mississippi State University, and was performed for the Simulation Based Reliability and Safety (SimBRS) research program.

Any opinions, findings and conclusions or recommendations expressed in this material are those of the author(s) and do not necessarily reflect the views of the U.S. Army TACOM Life Cycle Command.

BACKUP

Material properties

- Yield stress and elastic modulus depend on
 - Relative density (density of foam/density of solid)
 - Distribution constant (open cell vs closed cell)
- Compaction strain is only a function relative density

Relative density

$$\frac{\sigma_p}{\sigma_{y0}} = 0.3\phi^{3/2} \left(\frac{\rho_f}{\rho_0}\right)^{3/2} + (1 - \phi) \left(\frac{\rho_f}{\rho_0}\right)$$

$$\frac{E_f}{E_0} = 0.3\phi^2 \left(\frac{\rho_f}{\rho_0}\right)^2 + (1 - \phi) \left(\frac{\rho_f}{\rho_0}\right)$$

$$\varepsilon_d = 1 - 1.4 \left(\frac{\rho_f}{\rho_0}\right)$$