

271

**ARCHIVE COPY
DO NOT LOAN**

**AN IMPROVED STRAIN GAGE SIGNAL CONDITIONER FOR
DYNAMIC STRESS MEASUREMENT**

**B. G. Mahrenholz
Sverdrup Technology, Inc.**

Approved for public release; distribution unlimited.

*per Virgil E. Short
PA*

October 1990

Final Report for Period October 1, 1989 through
September 30, 1990

**TECHNICAL REPORTS
FILE COPY**

PROPERTY OF U.S. AIR FORCE
AEDC TECHNICAL LIBRARY

Distribution authorized to U. S. Government agencies
and their contractors; administrative and operational
use, September 1990. Other requests for this document
shall be referred to DOT/Arnold Air Force Base, TN
37389-5000.

WARNING

This document contains technical data whose export is
restricted by the Arms Export Control Act (Title 22,
U.S.C., Sec 2751, et seq.) or The Export Administration
Act of 1979, as amended. Title 50, U.S.C. App. 2401,
et seq. Violations of these export laws are subject to
severe criminal penalties. Disseminate in accordance
with the provisions of AFR 80-34.

**ARNOLD ENGINEERING DEVELOPMENT CENTER
ARNOLD AIR FORCE BASE, TENNESSEE
AIR FORCE SYSTEMS COMMAND
UNITED STATES AIR FORCE**

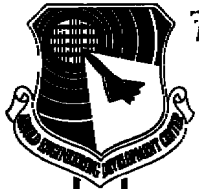

AEDC TECHNICAL LIBRARY



5 0720 00037 8051

Report Documentation Page

Form Approved
OMB No. 0704-0188

Public reporting burden for the collection of information is estimated to average 1 hour per response, including the time for reviewing instructions, searching existing data sources, gathering and maintaining the data needed, and completing and reviewing the collection of information. Send comments regarding this burden estimate or any other aspect of this collection of information, including suggestions for reducing this burden, to Washington Headquarters Services, Directorate for Information Operations and Reports, 1215 Jefferson Davis Highway, Suite 1204, Arlington VA 22202-4302. Respondents should be aware that notwithstanding any other provision of law, no person shall be subject to a penalty for failing to comply with a collection of information if it does not display a currently valid OMB control number.

| | | | | | |
|--|------------------------------------|---|-----------------------------|---------------------|---------------------------------|
| 1. REPORT DATE OCT 1990 | 2. REPORT TYPE | 3. DATES COVERED 01-10-1989 to 30-09-1990 | | | |
| 4. TITLE AND SUBTITLE An Improved Strain Gage Signal Conditioner For Dynamic Stress Measurement | | 5a. CONTRACT NUMBER | | | |
| | | 5b. GRANT NUMBER | | | |
| | | 5c. PROGRAM ELEMENT NUMBER | | | |
| 6. AUTHOR(S) | | 5d. PROJECT NUMBER | | | |
| | | 5e. TASK NUMBER | | | |
| | | 5f. WORK UNIT NUMBER | | | |
| 7. PERFORMING ORGANIZATION NAME(S) AND ADDRESS(ES) Sverdrup Technology Inc,Arnold Air Force Station,TN,37389 | | 8. PERFORMING ORGANIZATION REPORT NUMBER | | | |
| 9. SPONSORING/MONITORING AGENCY NAME(S) AND ADDRESS(ES) | | 10. SPONSOR/MONITOR'S ACRONYM(S) | | | |
| | | 11. SPONSOR/MONITOR'S REPORT NUMBER(S) | | | |
| 12. DISTRIBUTION/AVAILABILITY STATEMENT Approved for public release; distribution unlimited | | | | | |
| 13. SUPPLEMENTARY NOTES | | | | | |
| 14. ABSTRACT | | | | | |
| 15. SUBJECT TERMS | | | | | |
| 16. SECURITY CLASSIFICATION OF: | | | 17. LIMITATION OF ABSTRACT | 18. NUMBER OF PAGES | 19a. NAME OF RESPONSIBLE PERSON |
| a. REPORT unclassified | b. ABSTRACT unclassified | c. THIS PAGE unclassified | Same as Report (SAR) | 44 | |

NOTICES

When U. S. Government drawings, specifications, or other data are used for any purpose other than a definitely related Government procurement operation, the Government thereby incurs no responsibility nor any obligation whatsoever, and the fact that the Government may have formulated, furnished, or in any way supplied the said drawings, specifications, or other data, is not to be regarded by implication or otherwise, or in any manner licensing the holder or any other person or corporation, or conveying any rights or permission to manufacture, use, or sell any patented invention that may in any way be related thereto.

Qualified users may obtain copies of this report from the Defense Technical Information Center.

References to named commercial products in this report are not to be considered in any sense as an endorsement of the product by the United States Air Force or the Government.

DESTRUCTION NOTICE

For classified documents, follow the procedures in DoD 5220.22-M, Industrial Security Manual, Section II-19 or DoD 5200.1-R, Information Security Program Regulation, Chapter IX. For unclassified, limited documents, destroy by any method that will prevent disclosure or reconstruction of the document.

APPROVAL STATEMENT

This report has been reviewed and approved.

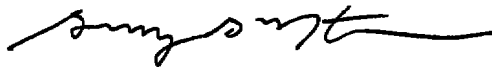

GREGORY G. NORDSTROM, 1st Lt, USAF
Facility Technology Division
Directorate of Technology
Deputy for Operations

Approved for publication:

FOR THE COMMANDER

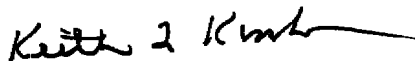

KEITH L. KUSHMAN
Technical Director
Directorate of Technology
Deputy for Operations

SUMMARY

Recent developments in turbojet engine testing have led to the reevaluation of the signal conditioning circuit used with single-active-arm strain gages for dynamic stress measurement. As may be expected, there is an increased demand for accuracy and for extended data bandwidth. Achievement of these requirements is made more difficult by the proliferation of fast rise time digital electronic circuitry with its accompanying generation of electrical noise. Also complicating the picture is the practice of engine manufacturers using small-diameter, high-resistance thermocouple wire as lead wire for the strain gages. The resistance of this wire changes significantly with temperature and also is unbalanced between the two leads.

A new signal-conditioning circuit has been developed under AEDC Air Force Project No. DC97EW that accommodates changing lead wire resistance without loss of accuracy and still maintains low noise and good common-mode rejection of unwanted electrical noise. This signal conditioner also includes a novel ΔR calibration circuit that provides a more accurate simulation of actual gage-resistance change.

TABLE OF CONTENTS

| | <u>Page</u> |
|--|-------------|
| SUMMARY | 1 |
| 1.0 INTRODUCTION | 5 |
| 1.1 Techniques for Eliminating Lead-Wire Errors | 5 |
| 1.2 Problems Associated With Constant-Current Technique | 6 |
| 1.3 Problems Associated With Constant-Voltage Technique | 6 |
| 1.4 Improved Signal Conditioner | 7 |
| 2.0 DESIGN APPROACH | 7 |
| 2.1 Correction for Lead-Wire Resistance | 7 |
| 2.2 Calibration Circuit | 9 |
| 2.3 Driving of Guard Shield | 10 |
| 2.4 Complete Conditioner | 11 |
| 3.0 TEST DESCRIPTIONS | 12 |
| 3.1 Regulation Accuracy | 12 |
| 3.2 Internal Noise | 12 |
| 3.3 Common-Mode Rejection | 12 |
| 4.0 RESULTS | 13 |
| 4.1 Regulation Accuracy | 13 |
| 4.2 Internal Noise | 13 |
| 4.3 Common-Mode Rejection | 14 |
| 4.4 Transient Common-Mode Rejection | 15 |
| 4.5 Calibration Signal Waveform | 16 |
| 5.0 RECOMMENDATIONS AND CONCLUSION | 17 |
| 5.1 Driving of Cable Shield as a Guard | 17 |
| 5.2 Calibration Circuit | 17 |
| 5.3 VACTROL® Devices and Control Circuitry | 17 |
| 5.4 Open Gage Circuit | 18 |
| 5.5 Evaluation of Other Vendors' Equipment | 18 |
| 5.6 Conclusion | 18 |
| REFERENCES | 19 |

ILLUSTRATIONS

Figure

| | |
|---|----|
| 1. Four-Wire Strain Gage Resistance Measurement | 20 |
|---|----|

TABLE OF CONTENTS

| | <u>Page</u> |
|--|-------------|
| 2. Dynamic Stress Measurement Using Constant-Current Excitation | 20 |
| 3. Dynamic Stress Measurement Using Constant-Voltage Excitation | 21 |
| 4. Constant-Current Excitation Source | 21 |
| 5. Loading of Gage Output by Excitation Supply | 22 |
| 6. Scheme for Lead-Wire Resistance Correction | 22 |
| 7. Circuit to Correct for Lead-Wire Resistance Change | 23 |
| 8. Parallel Combination of VACTROLS® | 24 |
| 9. Calibration Scheme | 24 |
| 10. Calibration Circuit Using Power MOSFET | 25 |
| 11. Effect of Unequal Lead-Wire Resistance on Common-Mode Rejection | 26 |
| 12. Input Cable With Driven Shield | 27 |
| 13. Block Diagram of Prototype Conditioner | 28 |
| 14. Prototype Conditioner | 29 |
| 15. Constant-Current Regulator for Neff Signal Conditioner | 30 |
| 16. Measurement of Conditioner Internal Noise | 31 |
| 17. Measurement of Common-Mode Rejection | 32 |
| 18. Common-Mode Rejection With Shield Floating at Sensor, Unbalanced Lead Resistances | 33 |
| 19. Common-Mode Rejection With Shield Tied to Common- Mode at Sensor, Unbalanced Lead Resistances | 34 |
| 20. Common-Mode Rejection With Shield Floating at Sensor, Balanced Lead Resistances | 35 |
| 21. Common-Mode Rejection With Shield Tied to Common Mode at Sensor, Balanced Lead Resistances | 36 |

TABLE OF CONTENTS

| | <u>Page</u> |
|--|-------------|
| 22. Circuit for Driving Cable Shield and Guard With Common Mode | 37 |
| 23. Improvement in Common-Mode Rejection With Driven Shield | 38 |

TABLES

| | |
|---|----|
| 1. Common-Mode to Normal-Mode Conversion for Circuit Shown | 39 |
| 2. Regulation Accuracy | 40 |
| 3. Internal Noise | 41 |
| 4. Transient Common-Mode Rejection | 42 |

1.0 INTRODUCTION

Dynamic stresses on the compressor and turbine blades of a turbojet engine are measured using resistance strain gages bonded to the blades. The resistance of the gages is normally either 120 or 350 ohms and exhibits a change of a fraction of an ohm when subjected to strain. Small diameter wire then connects the gage to a disconnect point located near the engine where permanent shielded cable runs to the location of the signal conditioning equipment. The small-diameter lead wire is normally unshielded and frequently has a significant resistance especially if thermocouple extension wire is used. Since the lead wire is subjected to temperature excursions as the engine is tested, the change in lead-wire resistance may be greater than the change in the gage resistance due to stress.

1.1 TECHNIQUES FOR ELIMINATING LEAD-WIRE ERRORS

There are several techniques for reducing or eliminating errors due to lead-wire resistance changes. The most accurate scheme is to use the four-wire resistance measurement circuit that uses separate leads for voltage and current. As shown in Fig. 1, two of the wires are used to provide a constant current through the gage. Since it is fed from a constant-current source, the current through the gage will be the same regardless of the lead resistances. The other two wires are then used to measure the voltage right across the gage. If the recorder input resistance is much higher than the lead resistances (R_L), there is no significant drop in the leads and the recorder shows the actual voltage across the gage, thereby eliminating any effect of lead resistance. Unfortunately, this scheme doubles the number of lead wires coming from the engine. In an already constricted location, additional lead wires cannot be tolerated.

When measuring dynamic stress, it is possible to AC or capacitively couple the recorder to the gage so that only two lead wires are needed. As shown in Fig. 2, a change in the gage resistance (ΔR) produces the same change in voltage (ΔV) across the gage regardless of the value of the R_L since the current through the gage is constant. If the lead resistances (R_{L1} , R_{L2}) vary slowly with respect to the data, the voltage across each R_L is essentially constant so the ΔV seen by the recorder is not affected. Normally, R_L changes due to temperatures, which is a very slow change.

A third approach is to use a constant-voltage excitation supply with series or ballast resistances in lieu of a constant-current supply (see Fig. 3). If the ballast resistances are made large enough, changes in R_L will have a minimal effect on the current through the gage and will cause minimum loading on the output of the gage. In this condition, its performance approaches that of the constant-current excitation circuit.

However, maximum gage output for a given excitation voltage occurs when $R_{B1} + R_{B2}$ equals $R_{L1} + R_{GAGE} + R_{L2}$.

1.2 PROBLEMS ASSOCIATED WITH CONSTANT-CURRENT TECHNIQUE

There are several problems associated with the constant-current excitation technique. First, the constant-current generator must respond fast enough to keep the current through the gage constant even with resistance changes up to 100,000 times a second. This requires a supply with a fast slew rate capable of driving the capacitive load of the shielded cable to the gage.

Although such devices are available for a constant-current supply, there are other problems. The second problem with a constant-current circuit is noise resulting from the wide bandwidth of the supply. The broadband noise, N , associated with any active device is given by the equation:

$$N = \sqrt{4kTBR}$$

where k is a constant, T is the absolute temperature, B is the bandwidth and R is the resistance. Since a constant-current regulator has such a wide bandwidth, it follows that the noise in its output must be considerably greater than that of a constant-voltage supply whose bandwidth is typically limited by the large filter capacitor in its output.

The third problem with the constant-current circuit is not so obvious. A constant-current excitation source usually consists of a constant-voltage power supply with a constant-current regulator on its output (see Fig. 4). Since ideally a constant-current source has an infinite resistance, the excitation source as seen by the recorder and gage has a low impedance to the power supply in one lead and a very high impedance to the power supply in the other lead. This unbalanced condition diminishes the ability of the recorder to reject common-mode signals (stray signals induced equally in the two lead wires).

1.3 PROBLEMS ASSOCIATED WITH CONSTANT-VOLTAGE TECHNIQUE

These problems of the constant-current circuit are not present with the constant-voltage excitation scheme shown in Fig. 3. The circuit, however, is sensitive to changes in R_L . Changes in R_L affect the output in two ways: first, changes in R_L will change the current through the gage and different output signals (ΔV) will result from the same ΔR ; second, the output seen by the recorder is a function of the voltage divider made up of $R_{L1} + R_{L2} + R_{GAGE}$ and $R_{B1} + R_{B2}$. Consequently, as R_L changes, the fraction of the gage output seen by the recorder

changes. Figure 3 has been redrawn in Fig. 5 to show this effect. The only way to minimize the problem would be to greatly increase the values of R_{B1} and R_{B2} . This would require a very high voltage power supply and large-wattage resistors for R_{B1} and R_{B2} . Also, as R_{B1} and R_{B2} are increased in value, circuit balance becomes more sensitive to stray resistances and capacitances, and common-mode rejection suffers.

In summary, the constant-current technique is noisy and has poor common-mode noise rejection, while the constant-voltage technique is sensitive to lead-resistance changes.

1.4 IMPROVED SIGNAL CONDITIONER

A strain-gage signal conditioner has been designed and prototyped which will eliminate the problems associated with the constant-current type conditioner and still be insensitive to changes in lead-wire resistance. This conditioner also uses a novel calibration circuit which produces a ΔR resistance change exactly equivalent to the resistance change of the strain gage and eliminates the errors associated with calibration by millivolt substitution. Finally, the conditioner uses a driven input cable shield to minimize the reduction in common-mode rejection caused by the cable capacitances and an unbalanced source resistance due to the use of thermocouple-lead wire.

The work reported herein was conducted at the Arnold Engineering Development Center (AEDC), Air Force Systems Command (AFSC), under Program Element 65807F, at the request of AEDC/DOT, Arnold Air Force Base, Tennessee. The results were obtained by Sverdrup Technology, Inc., AEDC Group (a Sverdrup Corporation company), operating contractor of the propulsion test facilities, AEDC, AFSC, Arnold Air Force Base, Tennessee, under Air Force Project No. DC97EW during the period October 1, 1989 through September 30, 1990. The AEDC/DOT Project Manager was 1Lt G. G. Nordstrom. The Sverdrup Project Manager was Mr. T. F. Tibbals.

2.0 DESIGN APPROACH

2.1 CORRECTION FOR LEAD-WIRE RESISTANCE

After some effort to develop a constant-current excitation supply having balanced impedances in its output leads, it was recognized that the best performance as far as internal noise and the rejection of stray signals are concerned is obtained with the conditioner using a constant-voltage excitation supply. It was then decided to use constant-voltage excitation but to devise a means of compensating or correcting for the change in lead resistance. The solution was to add variable resistors, in series with the lead wires, which could be varied to keep the total resistance constant. As long as the total-loop resistance remained constant, the current through the gage and the loading on the gage would remain constant so the output signal would not

change (see Fig. 6). Since the lead-wire resistance changes slowly with time, the resistance change can be distinguished from that of the gage, which changes very rapidly.

If the total-loop resistance is constant, the voltage between points A and B is constant. This voltage is sensed and used to control the series resistances. The resistances are split equally in each lead to keep a balanced situation.

Several candidate devices were considered for the variable resistances. Theoretically, motor-driven, ganged potentiometers (pots) would be ideal. The resistance of the two pots could be made to track very closely, and the response time of a motor-driven pot would be adequate since the lead-wire resistance changes very slowly. Even though small (0.5-in.-diam) motors and pots are now available, it was felt that since in this application the motor would be continuously hunting or controlling, the life of the pot might be less than desirable.

The next device considered was the power MOSFET. These devices have a desirably low "on" resistance and require very little power to control. An N-channel device would be required in the negative lead and a P-channel device would be used in the positive excitation lead. With these devices, isolation from the control circuit becomes involved and tracking between the devices may be a problem. Also there were concerns about noise and the devices not looking like true resistances, particularly at high frequencies.

The device finally selected was a lamp/photoconductive cell combination such as the VACTROL[®] manufactured by EG&G Vactec (Ref. 1): Although several manufacturers make these devices, the Vactec Model VTL5C4 has the lowest "on" resistance for a light-emitting diode (LED) lamp-type device. Devices using incandescent lamps have a lower "on" resistance but are microphonic due to the filament of the lamp.

A circuit was designed using the VTL5C4 to provide a variable resistance in each gage lead that would vary between 150 to 50 ohms to accommodate lead resistances between 0 and 100 ohms. (The total resistance in each lead would always total 150 ohms.) The resultant circuit is shown in Fig. 7. The voltage difference between points A and B is sensed by the lower instrumentation amplifier and then compared against a reference voltage by the error amplifier. The output of the error amplifier is buffered by a current driver and drives the LEDs of the VACTROL LED/photoconductive cells. The compensation capacitor in the error amplifier limits the amplifier bandwidth so it will not respond to the rapid resistance changes of the gage. The upper instrumentation amplifier provides an AC-coupled strain signal to the data system.

To obtain a control device that would have a resistance range of 50 to 150 ohms using the available LED/photoconductive

cells, it was necessary to use two of the EG&G Vactec Model VTL5C4 devices in parallel with a 150-ohm resistor (see Fig. 8). One of these parallel combinations is used in each lead wire.

In operation, if the lead resistances should increase, the voltage between points A and B of Fig. 7 will increase. This will result in a greater positive voltage into the error amplifier and a greater signal out. More current then will be driven through the VACTROL LEDs reducing the resistance of the photoconductive cells and correcting for the increased lead resistances. Since the circuit functions by maintaining a constant resistance in each sensor lead, the circuit has been named "constant-resistance." An invention disclosure has been submitted to the Air Force on the constant-resistance excitation technique.

2.2 CALIBRATION CIRCUIT

Calibration of dynamic strain-gage systems is customarily done by disconnecting the gage and its power supply from the input to the data instrumentation amplifier by means of relays and substituting a sine-wave signal from a calibration source. The amplitude of the calibration signal is related back to stress by an involved calculation involving Young's modulus, gage resistance, gage current, lead resistance, load resistance, etc. To simplify the calibration process and reduce the errors resulting from any change in lead resistance or gage excitation, a new calibration scheme was devised. This scheme uses a small resistor in series with the gage whose resistance is changed by an amount equal to the change in gage resistance produced by a given amount of strain. This relationship may be determined from manufacturer's specifications for the strain gage.

The circuit shown in Fig. 9 consists of a precision 10-ohm resistor in the negative excitation lead to the gage that is shunted by an R_{CAL} resistor to produce a resistance change that is equal to a similar resistance change in the gage. Typically, R_{CAL} might be 390 ohms, which will produce a 0.25-ohm change. A second 10-ohm resistor is placed in the positive excitation lead to maintain circuit balance. This technique might be compared to the shunt-resistance calibration of a commercial strain-gage pressure transducer.

Since the recording data system is capacitively coupled and will not sustain the level resulting from a step change in resistance for any length of time, the calibration switch is alternately opened and closed for 500 μ sec, producing a 1-kHz square-wave signal. The peak-to-peak value of this square wave is equivalent to a known value of peak-to-peak stress. It should be noted that this calibration scheme is usable with any type of strain-gage conditioner and will eliminate any errors caused by lead-wire resistance changes.

The difficulty in implementing the calibration scheme of Fig. 9 lies in the switch. There are high-speed relays that will operate at speeds approaching those required, but the life of these devices, which is quoted typically at 10^9 operations, might soon be consumed.

JFET transistors and CMOS switches are currently used for switching applications where high-speed switching and essentially infinite lifetimes are requirements. However, the "on" resistance of these devices is 50 to 100 ohms or more, which would cause an unacceptable error.

Power MOSFETS have recently become popular for use in switching-type power supplies and similar applications. To obtain maximum efficiency from the power supply, these devices have "on" resistances of less than an ohm. Although designed for switching high currents, the "on" resistances of a power MOSFET actually decrease slightly at low currents. As mentioned previously, the power MOSFET requires very little power to drive. Its gate appears as a capacitor. A Type IRF511 power MOSFET (Ref. 2) with an "on" resistance of 0.6 ohm was selected as the switching device.

Figure 10 shows the circuit arrangement used to drive the power MOSFET and isolate it from the rest of the circuit. The power MOSFET requires a positive pulse on its gate of at least 10 volts to rapidly turn it on. This is produced by a Hewlett-Packard type HCPL-2201 opto-isolator (Ref. 3) which has a totem pole output and will operate with V_{CC} voltages from 4.5 to 20 volts. The DC-DC converter is a Burr-Brown type 700 (Ref. 4) and requires an input of 15 volts DC. Its input/output capacitance is only 3 pF. The optical isolator is driven from a 1,000-Hz square-wave source. Exact amplitude is unimportant as long as it will turn on the LED of the isolator. Calibration accuracy is controlled by the 390-ohm R_{CAL} resistor.

An additional benefit of the square-wave calibration signal is that abnormalities in the frequency response anywhere in the measurement system may be readily detected. For example, rounding of the leading edge of the square wave would indicate poor high-frequency response; droop in the top would indicate poor low-frequency response.

2.3 DRIVING OF GUARD SHIELD

The common-mode rejection of a signal conditioner is adversely affected by any unbalance in the resistance of the signal leads such as caused by the use of thermocouple-lead wire with its unequal wire resistances. This unbalanced resistance combined with the capacitance-to-ground of the cabling between the sensor and the conditioner has a serious impact on the common-mode rejection of the conditioner at higher frequencies (see Fig. 11). Noise and other undesired signals are coupled as a common-mode signal into the sensor circuit. Because of the

cable capacitance, the unequal lead resistances cause unequal portions of this common-mode signal to be fed to the two instrumentation amplifier inputs, producing a normal-mode signal.

Table 1 shows this effect. A 1.0-v common-mode signal is fed from unbalanced source resistances of 100 and 140 ohms through a 100-ft two-wire shielded cable into an instrumentation amplifier. With a cable (Belden 8451) having a wire-to-wire capacitance of 34 pF/ft and a 67-pF/ft capacitance from wire to shield, the normal-mode signal generated at various frequencies is as shown in Table 1. For illustration purposes, the shield is shown connected directly to ground; normally there is some impedance between the shield input and the amplifier ground.

The procedure recommended by signal conditioner manufacturers to circumvent this problem is to tie the cable shield to the source of common mode so that the shield acts as a guard between the sensor leads and earth ground. With the same common-mode voltage on the signal leads and the shield, there is no difference in potential between one side of the cable capacitance and the other, and the capacitance effectively disappears. Equal common-mode signals are then present on the instrumentation amplifier's + and - inputs.

The problem in the real world is determining and connecting the shield to a single point that truly represents the entire source of common-mode voltage. A solution to the problem, frequently discussed in application notes and other literature (Refs. 5, 6, 7, 8, and 9) but rarely seen in commercial signal conditioners, is to drive the shield with a common-mode signal derived from the inputs to the amplifier. Two equal-value resistors are connected as a summing network between the + and - inputs of the instrumentation amplifier as shown in Fig. 12. The junction of the resistors then goes to a unity-gain, wide-band buffer amplifier that drives the cable shield. This circuit is included in the new conditioner.

Similar deterioration of common-mode rejection occurs because of the capacitance-to-ground of the excitation supply power transformer and by the stray capacitance of the conditioner input wiring. To maintain the common-mode rejection, the input circuitry is enclosed in a guard shield and the transformer secondary winding has a guard shield. These shields are also driven with the common-mode voltage by a buffer amplifier.

2.4 COMPLETE CONDITIONER

A block diagram of the prototype conditioner is given in Fig. 13. The unit was built up as a module that would plug into a Pacific Instruments Model 8202 mainframe in lieu of Pacific's 8000 Series transducer amplifier. The Model 8202 mainframe provides DC power for the conditioner and an AC supply for the

excitation rectifier and regulator in the conditioner. The prototype was built up on blank PC boards using integrated circuit (IC) sockets soldered to MINI-MOUNTS® which were stuck to the boards. A photograph of the prototype is shown in Fig. 14.

3.0 TEST DESCRIPTIONS

The prototype constant-resistance signal conditioner was tested for excitation regulation accuracy, internally generated noise, and for common-mode rejection. For comparison purposes, measurements of internal noise and common-mode rejection were made on a Neff Instrument Company (Neff) signal conditioning amplifier (SCA) in the constant-voltage mode and on the same Neff SCA with a constant-current regulator built up on the plug-in mode card (see Fig. 15).

3.1 REGULATION ACCURACY

Regulation accuracy is determined by measuring with a digital voltmeter the voltage developed across the sensor resistance for different values of lead-wire resistance. These voltages are then converted to the corresponding gage currents using Ohm's law. The voltages are measured with a 120-ohm gage resistance and lead resistances (in each lead) of 0, 20, 40, 60, 80, and 100 ohms.

3.2 INTERNAL NOISE

Internal noise comes from the input amplifier and the excitation supply of the conditioner and is a function of the bandwidth of the data amplifier. For comparison purposes, the noise is measured on all three conditioners using a bandwidth of 80 kHz. The low-pass filter in the Neff SCA is a 6-pole Bessel, while the prototype conditioner has only a 4-pole Bessel filter.

Internal noise is measured using the circuit shown in Fig. 16. Two series-connected 120-ohm metal film resistors are connected directly across the + and - signal input pins of the conditioner and their junction connected to the guard (shield) input. The resistors represent a 120-ohm strain gage and two lead wires each having a resistance of 60 ohms. The excitation is set to give 30 ma through the gage. The peak-to-peak noise is then measured at the output of the conditioner using a Tektronic Model 2465 oscilloscope with its bandwidth limited to 20 MHz.

3.3 COMMON-MODE REJECTION

Common-mode rejection is measured using the circuit of Fig. 17. The two 60-ohm resistors on the input represent the 120-ohm strain gage. The 80-ohm resistor and the 40-ohm resistor represent typical thermocouple-wire resistances. The 100 ft of Belden 8451 shielded-pair cable represents the wiring from the

test article to the signal conditioner location. Since the common-mode rejection is affected by the capacitance-to-ground of the input cable and its shield, the cable is wrapped around a metal cylinder that is connected to the conditioner output ground. Common-mode rejection is checked at 1, 2, 5, 10, 20, 50, and 100 kHz for each of the three conditioner types, with low-pass filters set for a bandwidth of 80 kHz.

Common-mode rejection is first measured on the signal conditioners with the sensor cable shield tied to the guard circuit of the amplifier but not connected at the sensor end. This is the customary practice in the Engine Test Facility (ETF). A second measurement of common-mode rejection is then made with the shield at the sensor end of the cable connected to the common-mode voltage source. The 40- and 80-ohm resistors simulating the lead-wire resistances are next all changed to 60 ohms to provide a balanced configuration and the above tests repeated. Finally, common-mode rejection is measured on the prototype conditioner with the unbalanced lead-wire configuration but with the cable shield driven with the common-mode signal derived in the conditioner from the input leads.

4.0 RESULTS

Various tests were performed as described above to assess the performance of the prototype strain-gage signal conditioner. The results of these tests are described in detail in the following sections.

4.1 REGULATION ACCURACY

The results of the measurement of regulation accuracy are given in Table 2. The change in current through the gage for the full 100-ohm change in gage resistance is less than 0.05 percent. The absolute error in setting the gage current to 30 ma (0.4 percent) is caused by the 1-percent tolerance resistors used. The current regulation obtained using the constant-resistance approach is considered very good. The current setting accuracy could be improved by substituting resistors of higher precision but is felt to be satisfactory for the ETF application.

4.2 INTERNAL NOISE

The internal noise measured for each of the three conditioners is shown in Table 3. The noise was measured as peak-to-peak millivolts at the output of the conditioner using a Tektronix oscilloscope with a 20-MHz bandwidth. This value was then divided by the gain of the amplifier (800X for the prototype and 256X for the Neff) to give noise in microvolts referred to the input (RTI).

The percent of full-scale signal was next calculated by dividing the RTI value by the full-scale voltage at the input to

the instrumentation amplifier and multiplying by 100. Full-scale voltage is defined as that voltage resulting from a 0.25-ohm change in a 120-ohm gage (4.35 mv for the constant-resistance circuit, 3.75 mv for the constant-voltage circuit, and 7.5 mv for the constant-current circuit). The results are given in Table 3 and illustrate that the constant-resistance circuit has a noise level less than the constant-current technique and comparable to that of the constant-voltage approach. In addition to the wide-band noise given in Table 3, the Neff constant-current conditioner had 60-Hz spikes having an amplitude of 217 μ v peak-to-peak (2.9 percent). These noise spikes are considered unacceptable for ETF dynamic data acquisition.

4.3 COMMON-MODE REJECTION

The common-mode rejection measurements were made with the input cable either floating at the sensor or tied to the common-mode source at the sensor, for both unbalanced and balanced lead resistances. The results for the three types of conditioners are shown in Figs. 18-21.

Generally, the common mode deteriorates at a rate of 6 dB per octave because of unbalanced input resistances and capacitances. Above about 50 kHz, the rolloff of the low-pass filter reduces the amount of signal at the conditioner output, thus improving the apparent common-mode rejection. At low frequencies, the common-mode rejection curve levels off when the common-mode signal level approaches the internal noise level of the conditioner. Actually, the 6 dB per octave slope continues on to below 60 Hz and could be measured by increasing the level of the common-mode signal applied to the conditioner. The increased common-mode input level, however, would cause amplifier overload at the higher frequencies of interest.

The inferior performance of the constant-current configuration may be noticed in each case. Also readily apparent is the very poor common-mode rejection obtained when the input cable shield is not tied to the source of common mode. It should be noted that to compare the performance between conditioner types, the common-mode rejection should be adjusted for the different full-scale signal levels as shown on the plots.

Considerable difficulty was encountered in trying to develop a circuit for driving the shield of the sensor cable with a common-mode signal derived from the input signal. Many circuits either oscillated or showed a tendency to oscillate under certain conditions. Usual measures taken to stabilize the circuits resulted in a marked decrease in common-mode rejection.

The length of the input cable was considered as a possible problem area, but Frederiksen (Ref. 10) states that a cable looks like a capacitance if its length is less than one-fortieth

of a wavelength. Morrison (Ref. 9) says that the driven shield technique is suitable for input lines whose length is less than one-eighth of a wavelength. For a 100-ft cable of the type being used (Belden 8451 or equal), 100 kHz is one-sixty-fifth of a wavelength. The particular length of the cable used in the test, therefore, should not have caused the oscillation problem.

Limited success in driving the guard shield was achieved using the circuit shown schematically in Fig. 22. Figure 23 shows the preliminary common-mode measurements made on the amplifier alone without the excitation supply connected. This is for the case of the shield floating at the sensor and unbalanced lead resistances. The improvement obtained proves that the shield driving technique is definitely worth pursuing. Further investigation should be conducted in this area to develop a circuit to drive the shield without inducing oscillations.

4.4 TRANSIENT COMMON-MODE REJECTION

While measuring the common-mode rejection of the conditioners it was discovered that if a waveform other than a sine wave is used, a disturbing phenomenon occurs. Apparently, in the case of the unbalanced lead resistances, a difference in signal arrival time occurs between the + and - inputs of the instrumentation amplifier because of the different R-C time constants of the lead resistance and the cable capacitance for each lead. With any waveform having fast step-like transitions, such as a square wave or a noise pulse, there occurs at one amplifier input a normal-mode signal approaching the full common-mode voltage for just an instant until the signal at the other input "catches up." The output of the amplifier then is a large amplitude spike whose width is a function of the time difference between the two inputs. (There are actually two spikes generated, one on the leading edge and a second of opposite polarity on the trailing edge of the pulse.) For pulses shorter than the difference in delay time between the two inputs, the width of the output pulse will be the same as the input pulse. The amplitude and width of the pulse output from the conditioner is then a function of the low-pass filter following the amplifier.

Measurements were made on the three conditioner types for pulses of various widths. For these measurements, a 0.5-v peak amplitude positive pulse was applied to the conditioner in the configuration shown in Fig. 17 and the resulting conditioner output measured on an oscilloscope. As before, 80 kHz low-pass filters were selected. The results are given in Table 4. The peak-to-peak measurements listed include both positive and negative pulses. Note that the amplitude of the output pulse shows no increase for input pulse widths greater than 10 μ sec. It is believed that the poorer transient common-mode rejection of the Neff conditioners is caused by a network consisting of a

0.22- μ f capacitor and a 56-ohm resistor in series from the cable-shield input to amplifier ground.

The only way to reduce the output spikes caused by noise pulses is to reduce the cable capacitance or the resistive unbalance in the source leads. The cable capacitance may be reduced by using a shorter run of cable (locating the conditioner closer to the sensor) or by going to a lower capacitance cable (cables are available having a capacitance one-fourth of those presently used). With lower capacitance, the spikes are narrower and are further reduced by the low-pass filter in the conditioner. Fortunately, the technique of reducing effective cable capacitance by driving the cable shield also reduces transient spiking.

4.5 CALIBRATION SIGNAL WAVEFORM

The power MOSFET used in the calibration circuit to switch the R_{CAL} resistor adds small sharp spikes to the trailing edge of the square-wave calibration signal. These are a result of the MOSFET gate-driving signal being charge-coupled to the output of the device. Although reduced by the low-pass filter in the amplifier, they are still somewhat noticeable on the output at the higher frequency low-pass filter settings. Additional study is needed to determine whether or not the spikes would be objectionable.

Also noticeable on the output waveform is a small 160-kHz ripple from the DC-to-DC converter used to power the optical isolator. Although the converter is magnetically and electrically shielded, a small component of the switching frequency is noticeable at the millivolt levels at which the circuit is working. This ripple is considered unacceptable, and further investigation is needed to find a more suitable DC-to-DC converter or to go to a different technique for supplying power to the calibration circuit.

Optically-coupled power MOSFETs from Aromat Corporation (Type AQV221 Photo-MOS) were tried in the calibration circuit. These devices do not require a separate isolated power supply and may be driven directly from TTL signals. By placing one device in the positive-signal lead and a second in the negative-signal lead, the gate-charge spikes may be canceled out. These devices do not have as low an "on" resistance as the IRF511 and so require two devices in parallel for a satisfactorily low "on" resistance (making a total of four devices). Two R_{CAL} resistors, each of twice the value, are also required. It was found that the use of the two Photo-MOS devices did eliminate the spikes. Although more MOSFETs are used, the DC-to-DC converter is no longer required.

The main disadvantage of the Photo-MOS switching devices is their switching speeds which are measured in the tens of microseconds. They have different turn-on and turn-off times

which produce a square wave having other than a 50-percent duty cycle. The units evaluated produced a square wave with 49-percent "on" and 51-percent "off" times. Further study is required to determine if this nonsymmetrical square wave will cause a problem in the calibration process.

5.0 RECOMMENDATIONS AND CONCLUSION

A prototype strain-gage signal conditioner has been assembled and tested. The constant-resistance excitation technique and the ΔR calibration circuit have been proven to work as desired. There are, however, several areas discussed in the following sections that require further development and/or refinement before the conditioner is ready for deployment.

5.1 DRIVING OF CABLE SHIELD AS A GUARD

The one area that promises the largest return is that of reducing the effect of the capacitance of the sensor cable by driving the shield with the common-mode signal. As shown in Fig. 23, an improvement in common-mode rejection of over 20 db at all frequencies could possibly be obtained. An additional benefit would be the improved common-mode rejection of noise transients. Further research should be performed to investigate techniques and the governing parameters for driving the shield in this application.

5.2 CALIBRATION CIRCUIT

To reduce the ripple on the calibration signal, other DC-DC converters should be surveyed to find a unit with greater input/output isolation or a higher switching frequency. In addition, the AEDC data reduction process for dynamic data should be studied to determine which of the two ΔR calibration circuits produces a more suitable calibration signal and whether the trailing edge spikes or the nonequal duty cycle will present a problem.

5.3 VACTROL DEVICES AND CONTROL CIRCUITRY

The VACTROL devices and their control circuitry could benefit from additional study. While offering excellent isolation, long life, and fast response, the VACTROLs have a somewhat greater $1/f$ noise than desired which, at present, is the limiting factor in the dynamic range of the conditioner. Also, the associated control circuitry, while providing excellent regulation, has been found to be underdamped, which might be contributing to the noise. A further analysis of the control loop is in order.

The VACTROL devices used in the prototype were selected and matched to provide a balanced circuit. The degree of matching required and whether it should be done at the factory or in the field should be investigated. This could drastically affect the

consistency of multiple channels of this signal conditioner and the cost of manufacturing.

5.4 OPEN GAGE CIRCUIT

A circuit should be added to the conditioner that will clamp the excitation voltage, disable the drive to the VACTROL LED, and turn on a front panel indicator light in the event of an open gage. This will simplify troubleshooting of the strain-gage system and also prolong the life of the VACTROL devices.

5.5 EVALUATION OF OTHER VENDORS' EQUIPMENT

It could be worthwhile to evaluate other manufacturers' signal conditioners. The investigation so far has mainly involved those units available at AEDC. Investigating how other manufacturers' equipment reacts to common-mode signals may be beneficial to this work and would provide a baseline for comparison of the techniques.

5.6 CONCLUSION

A prototype conditioner has been developed having balanced output circuitry that maximizes the rejection of high-frequency, common-mode signals. Much of the common-mode rejection problem, however, lies in the signal wiring between the strain gage and the conditioner. By use of the driven-guard technique, the conditioner can improve upon this situation.

The constant-resistance excitation technique eliminates changes in lead-wire resistance from affecting the system accuracy. The ΔR calibration circuit provides a more direct relation to the actual gage-resistance change.

Further research is needed to refine the prototype as described above and to then produce six to ten units for field evaluation in one of the ETF test cells. After successful completion of field testing, the number of units needed for stress testing in the ETF would be produced. This could be accomplished either in-house or contracted to an experienced manufacturer of signal-conditioning equipment. In-house fabrication would require the evaluation and selection of electronic components and an extensive hardware packaging design effort to minimize noise. Outside procurement would require the preparation of a thorough set of specifications dictating the design based upon available components, selection of qualified vendors, and a thorough ETF evaluation of the final product prior to acceptance. The continuation of this project will address the design refinements and make an assessment of the best approach for implementation in the ETF.

REFERENCES

1. Optoelectronics. EG&G VACTEC, St. Louis, MO, pp. 39-48.
2. HEXFET Power MOSFET Databook. International Rectifier, El Segundo, CA, 1984, pp. D-97 through D-102.
3. Optoelectronics Designers Catalog 1988-1989. Hewlett-Packard, Palo Alto, CA, 1987, pp. 9-15 through 9-18.
4. Integrated Circuits Data Book, Volume 33. Burr-Brown Corporation, Tucson, AZ, 1989, pp. 4-86 and 4-87.
5. Analog IC Data Book. Precision Monolithics Inc., Santa Clara, CA, 1990, pp. 6-17, 6-18, and 6-59.
6. Linear Databook 1. National Semiconductor Corporation, Santa Clara, CA, 1988, pp. 2-53, 5-58, and 5-59.
7. The Handbook of Linear IC Applications. Burr-Brown Corporation, Tucson, AZ, 1987, pp. 142, 154, and 155.
8. Linear Products Data Book. Analog Devices, Norwood, MA, 1988, pp. 4-32.
9. Morrison, Ralph. Grounding and Shielding Techniques in Instrumentation. John Wiley & Sons, New York, NY, 1986 (Third Edition), pp. 161-162.
10. Frederiksen, Thomas M. Intuitive IC Op Amps. National Semiconductor Corporation, Santa Clara, CA, 1984, pp. 155-157.
11. Relay Catalog. Aromat Corporation, New Providence, NJ, 1989, pp. 259-279.

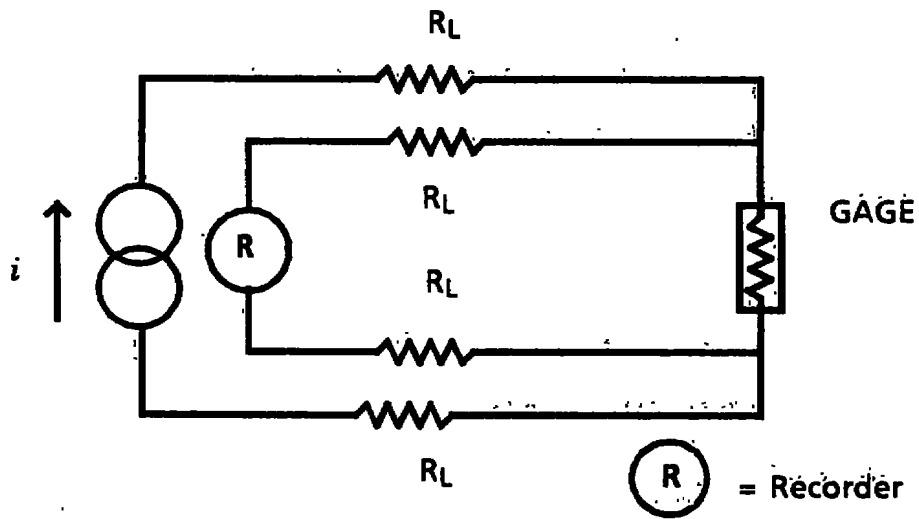

Figure 1. Four-Wire Strain Gage Resistance Measurement.

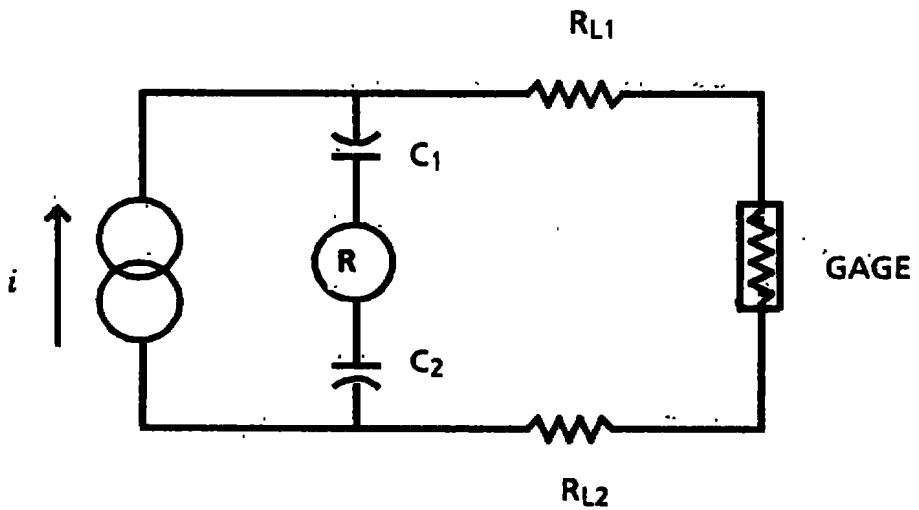

Figure 2. Dynamic Stress Measurement Using Constant-Current Excitation.

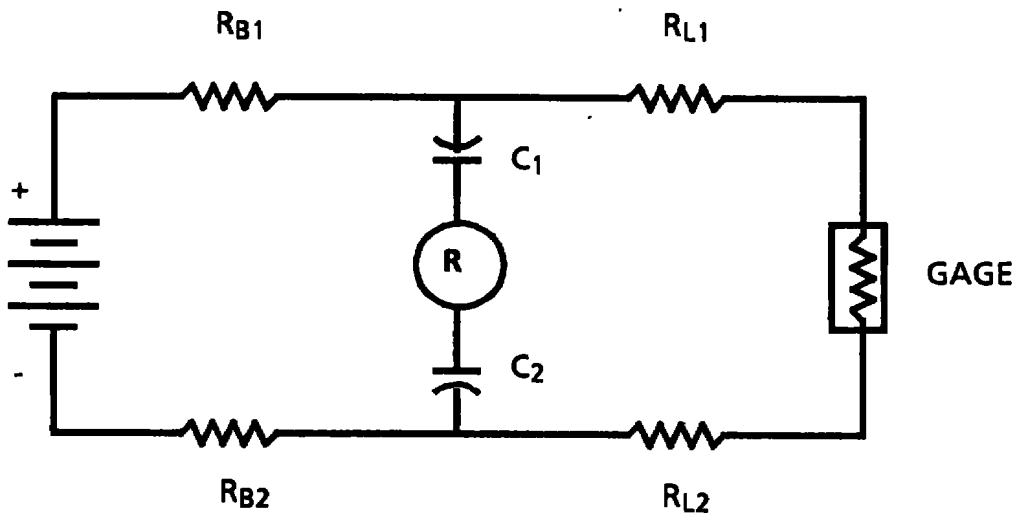

Figure 3. Dynamic Stress Measurement Using Constant-Voltage Excitation.

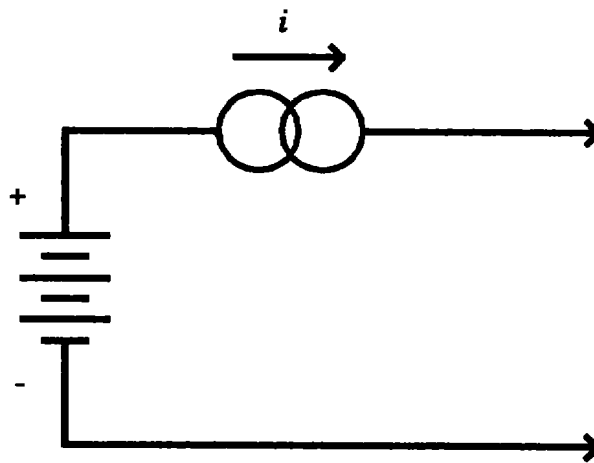

Figure 4. Constant-Current Excitation Source.

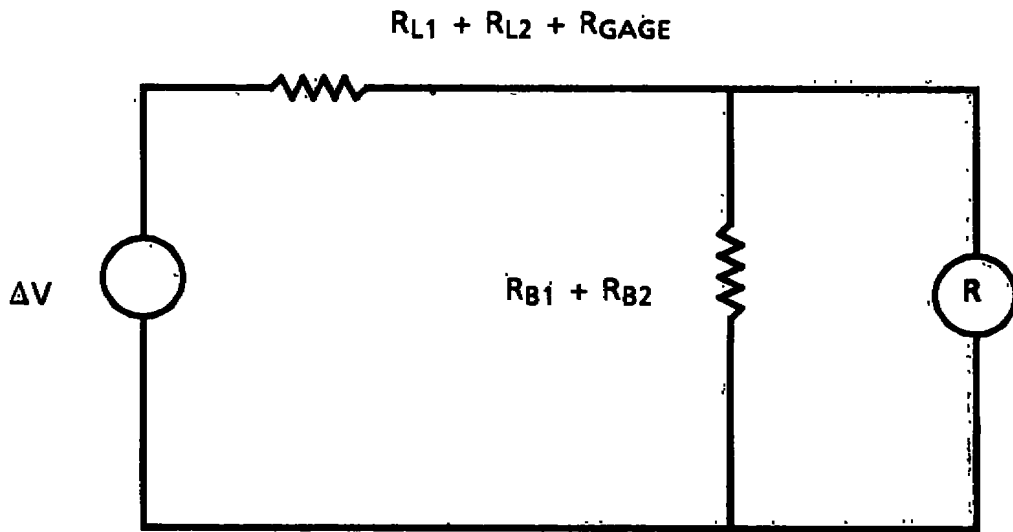

Figure 5. Loading of Gage Output by Excitation Supply.

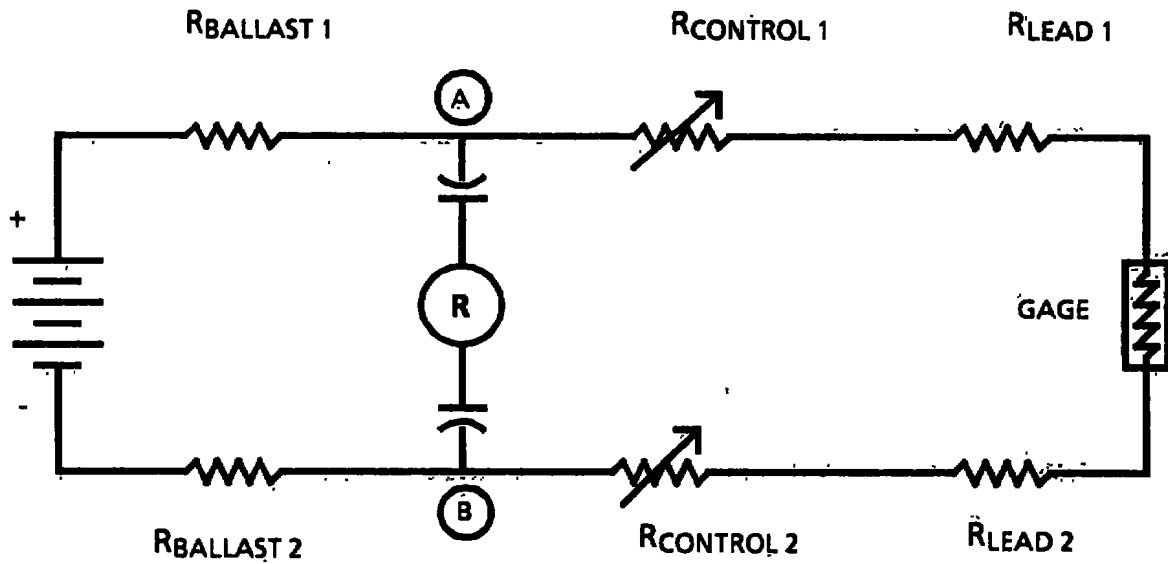

Figure 6. Scheme for Lead-Wire Resistance Correction.

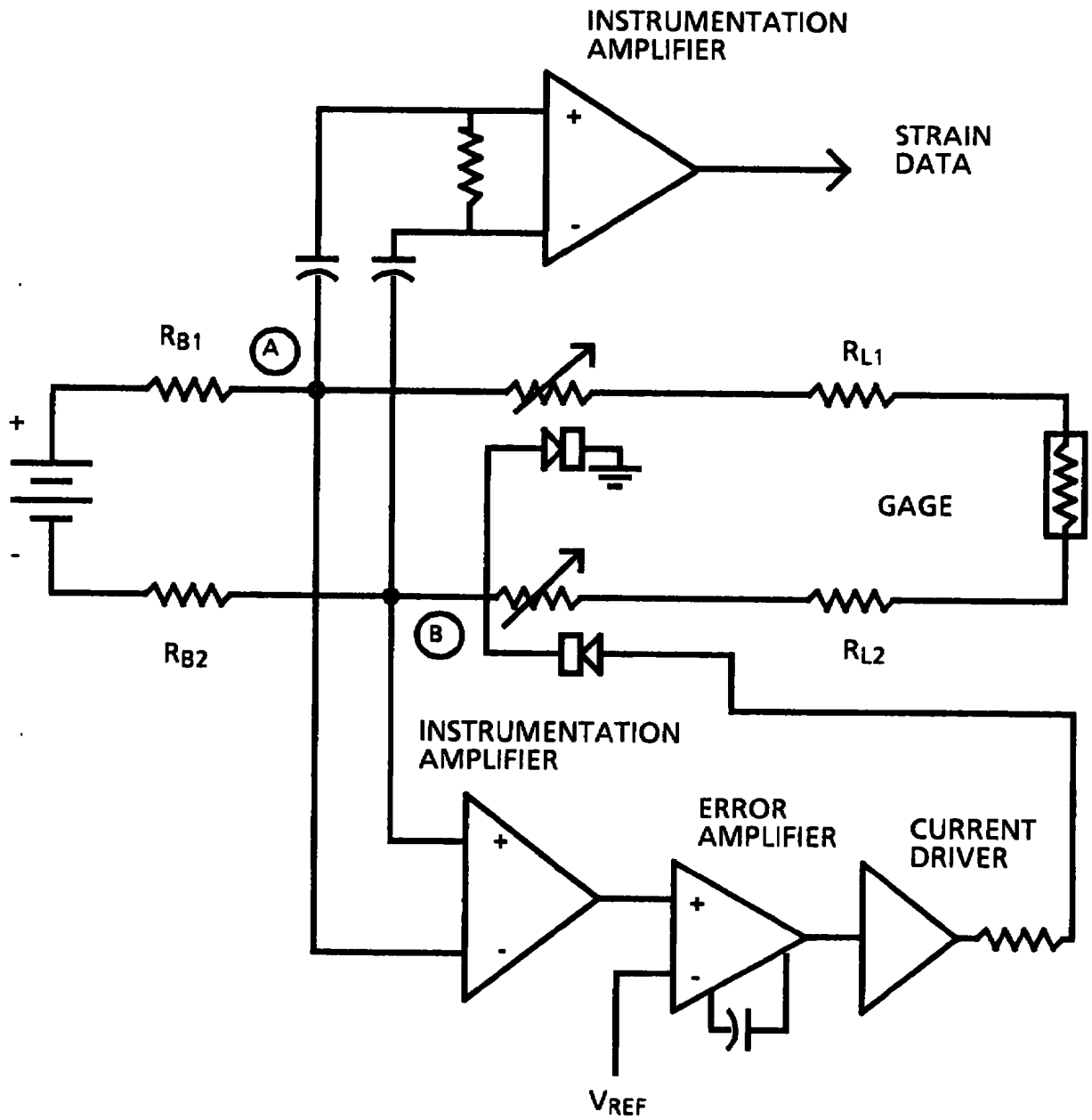

Figure 7. Circuit to Correct for Lead-Wire Resistance Change.

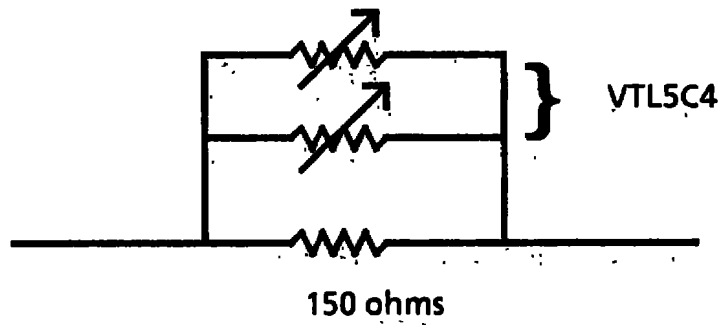

Figure 8. Parallel Combination of VACTROLs®.

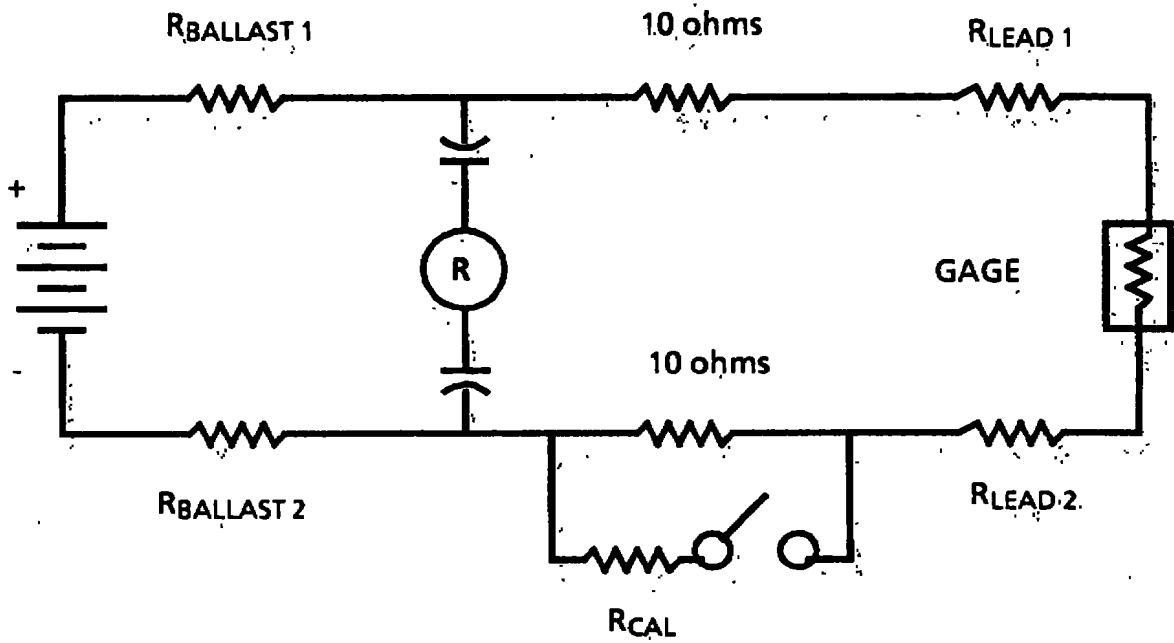

Figure 9. Calibration Scheme.

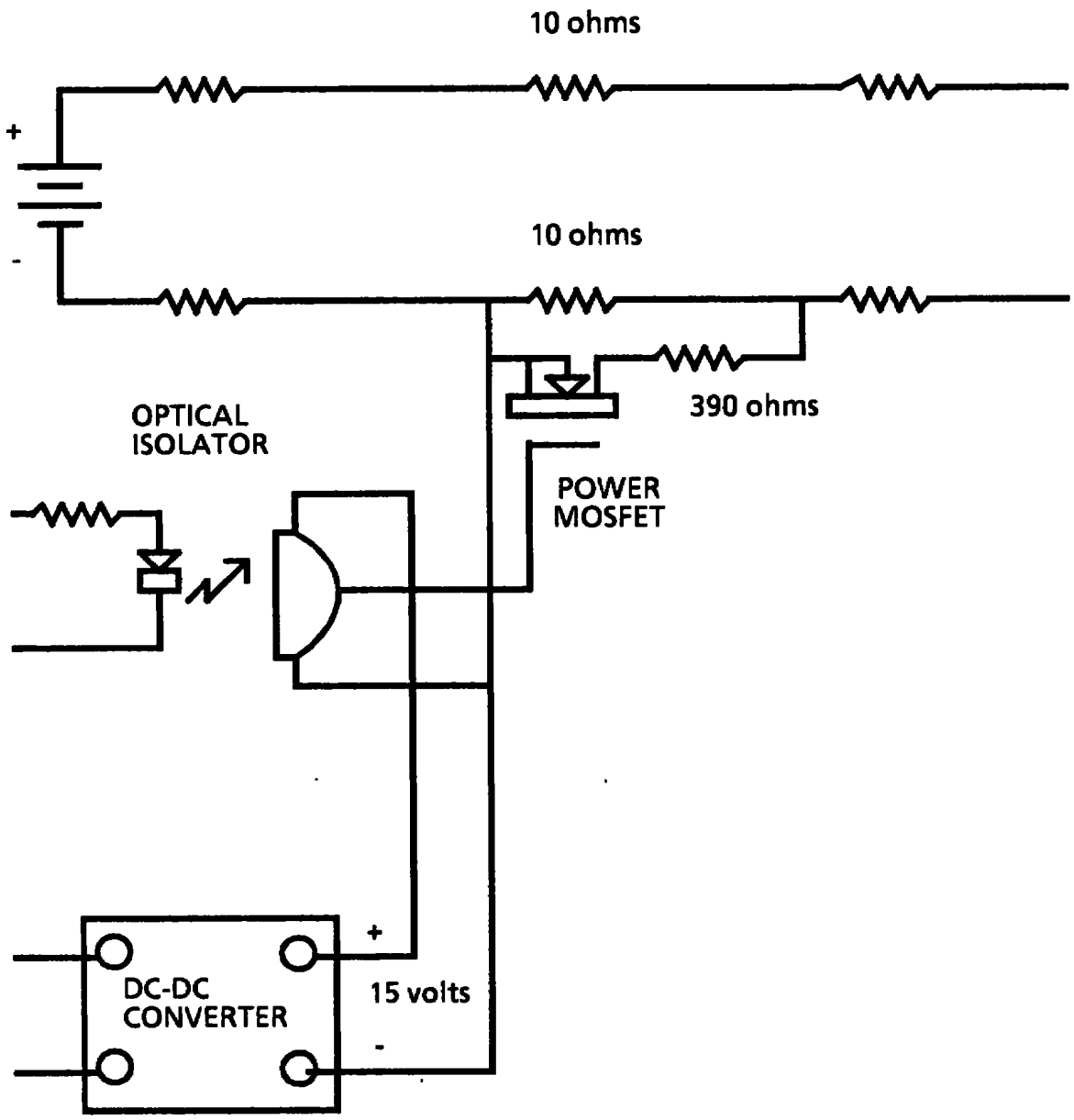
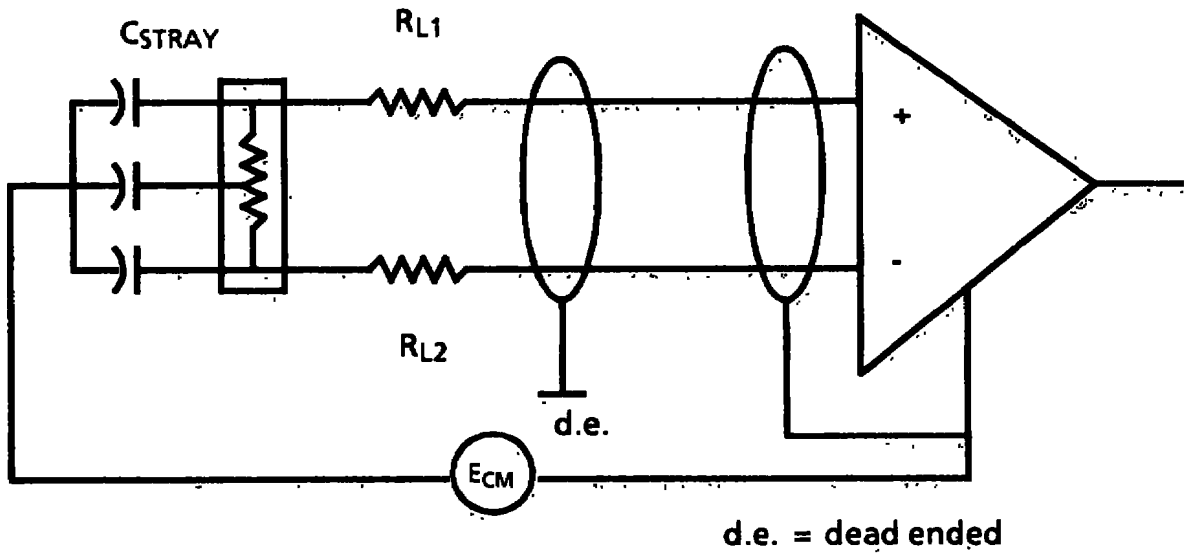

Figure 10. Calibration Circuit Using Power MOSFET.

ACTUAL CIRCUIT



EQUIVALENT CIRCUIT

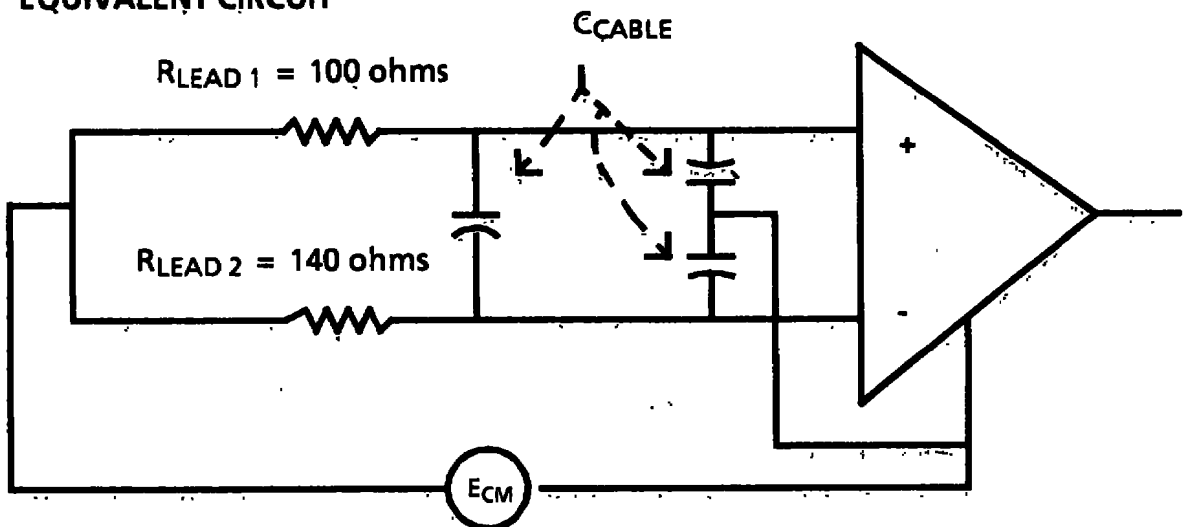

Figure 11. Effect of Unequal Lead-Wire Resistance on Common-Mode Rejection.

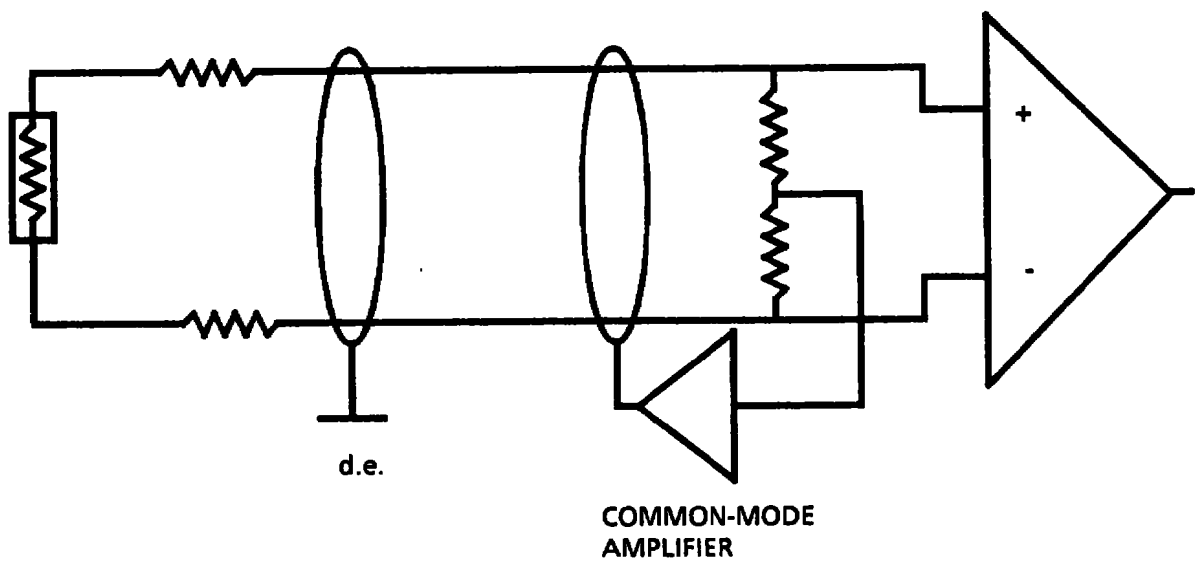
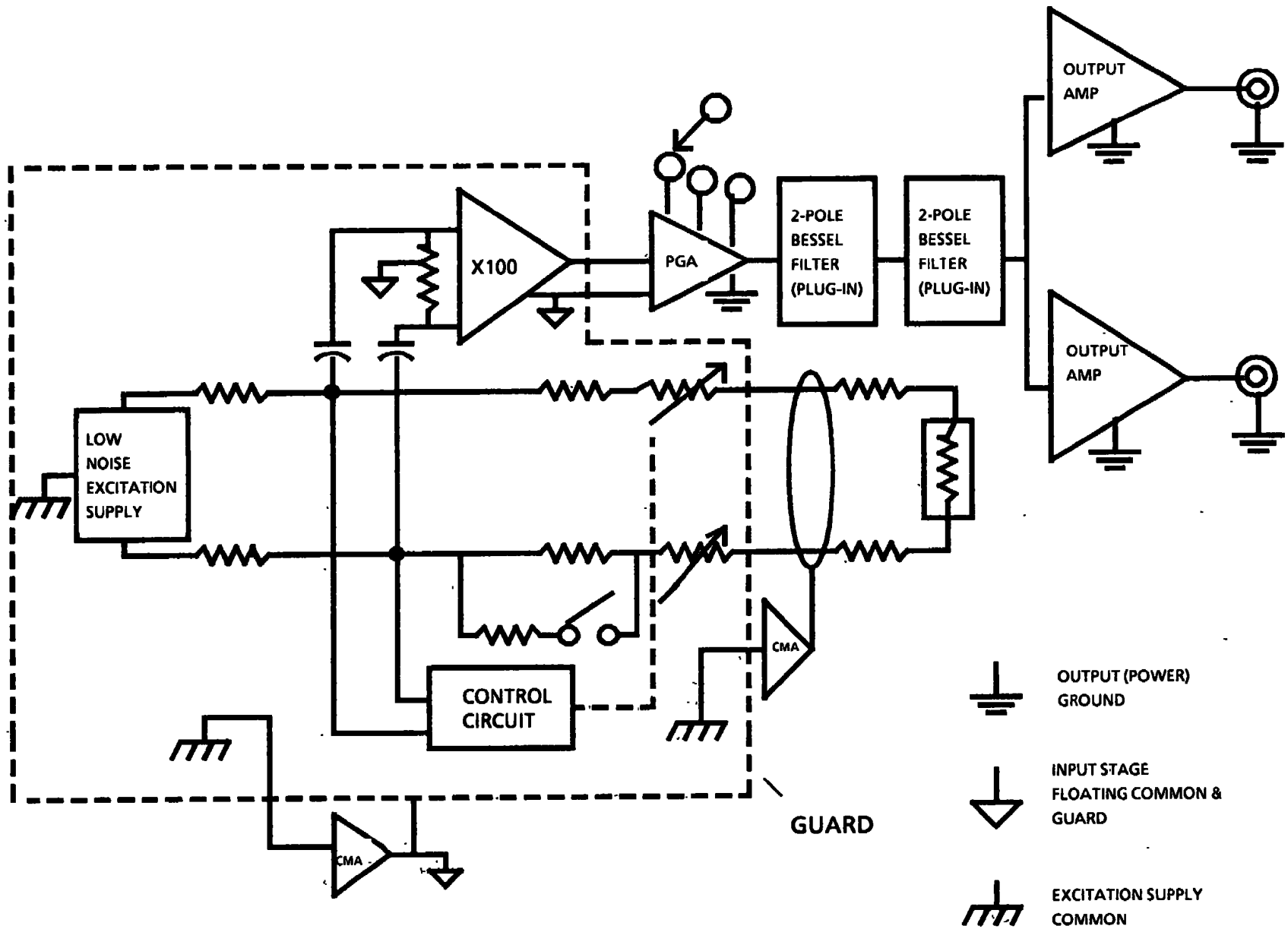

Figure 12. Input Cable With Driven Shield.



PGA = Programmable Gain Amp
 CMA = Common-mode Amp

Figure 13. Block Diagram of Prototype Conditioner.

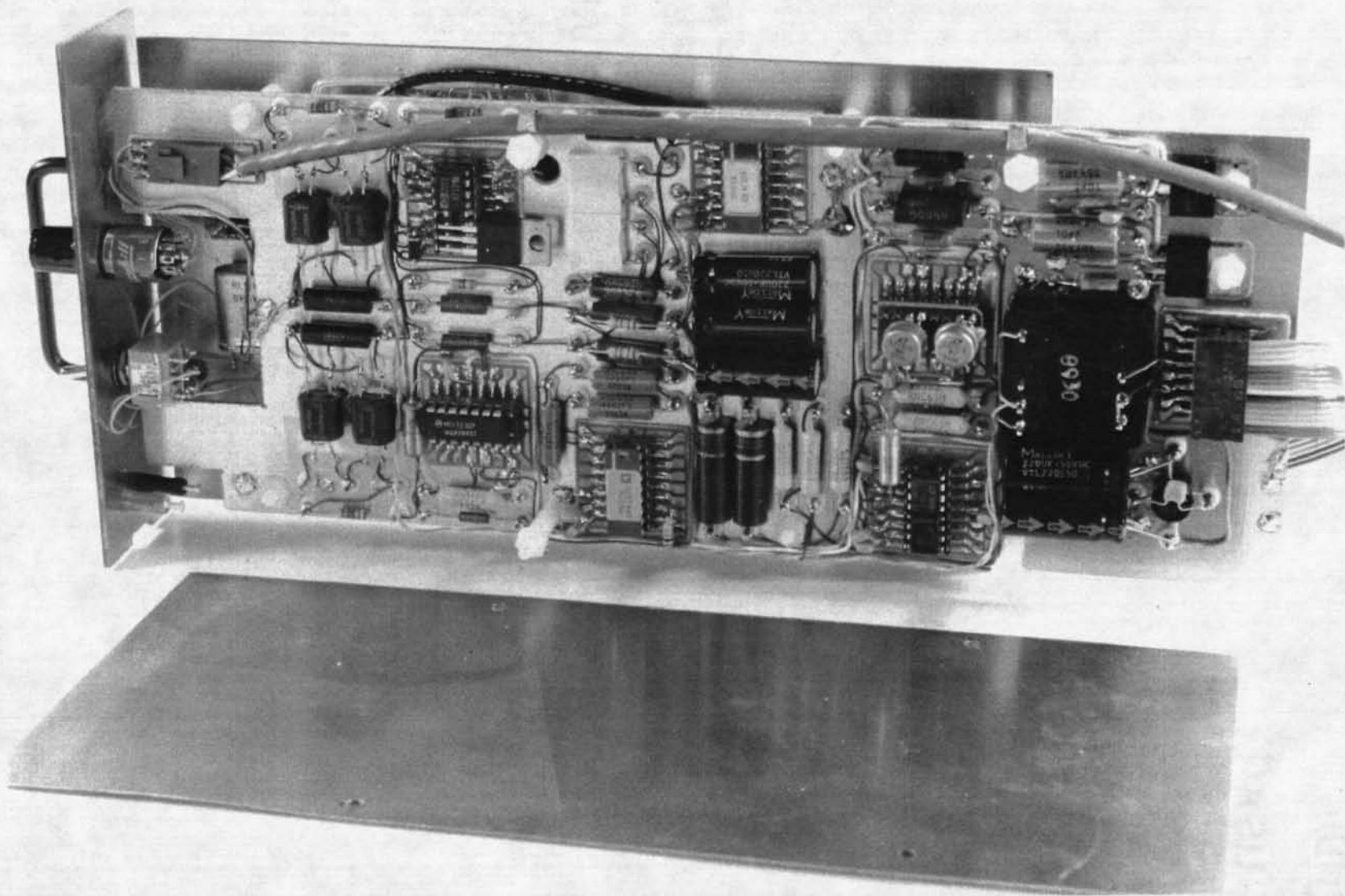

Figure 14. Prototype Conditioner.

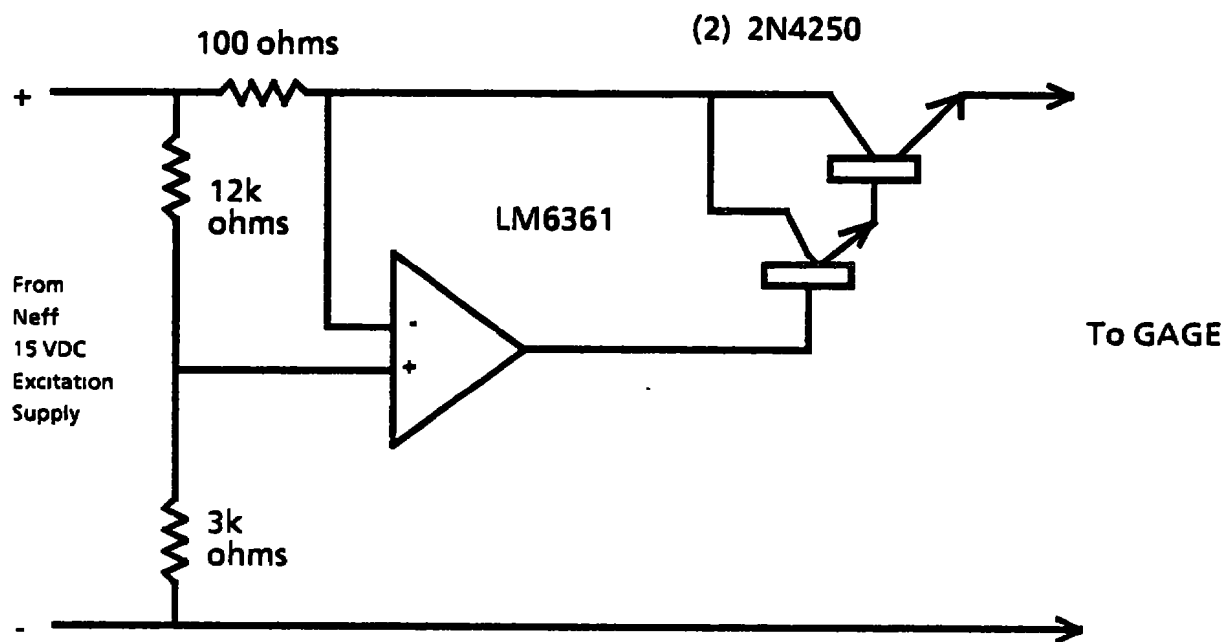
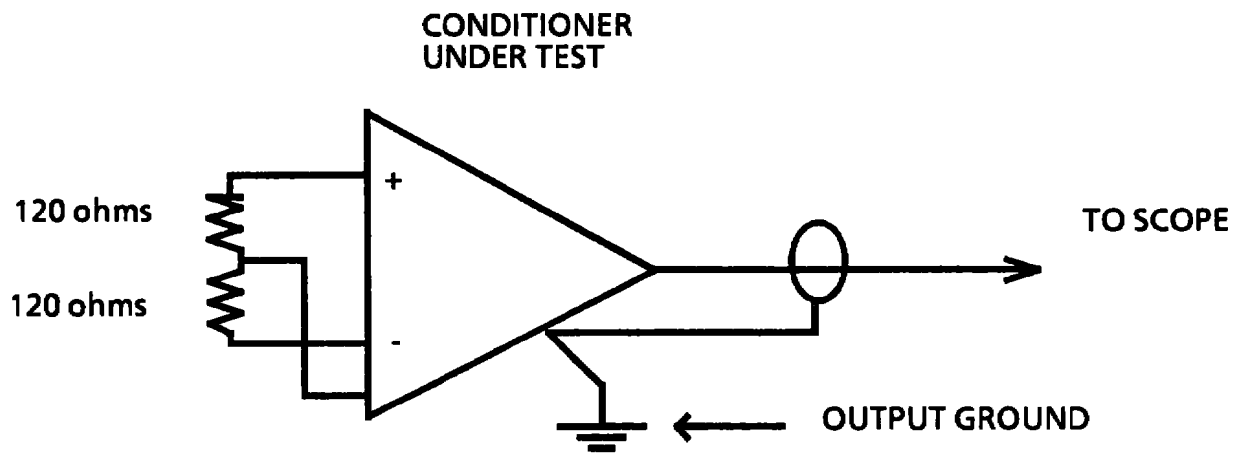

Figure 15. Constant-Current Regulator for Neff Signal Conditioner.



NOTES:

1. Use internal R_{Cal} circuit and calculate signal-to-noise ratio.
2. Install resistor on input connector.

Figure 16. Measurement of Conditioner Internal Noise.

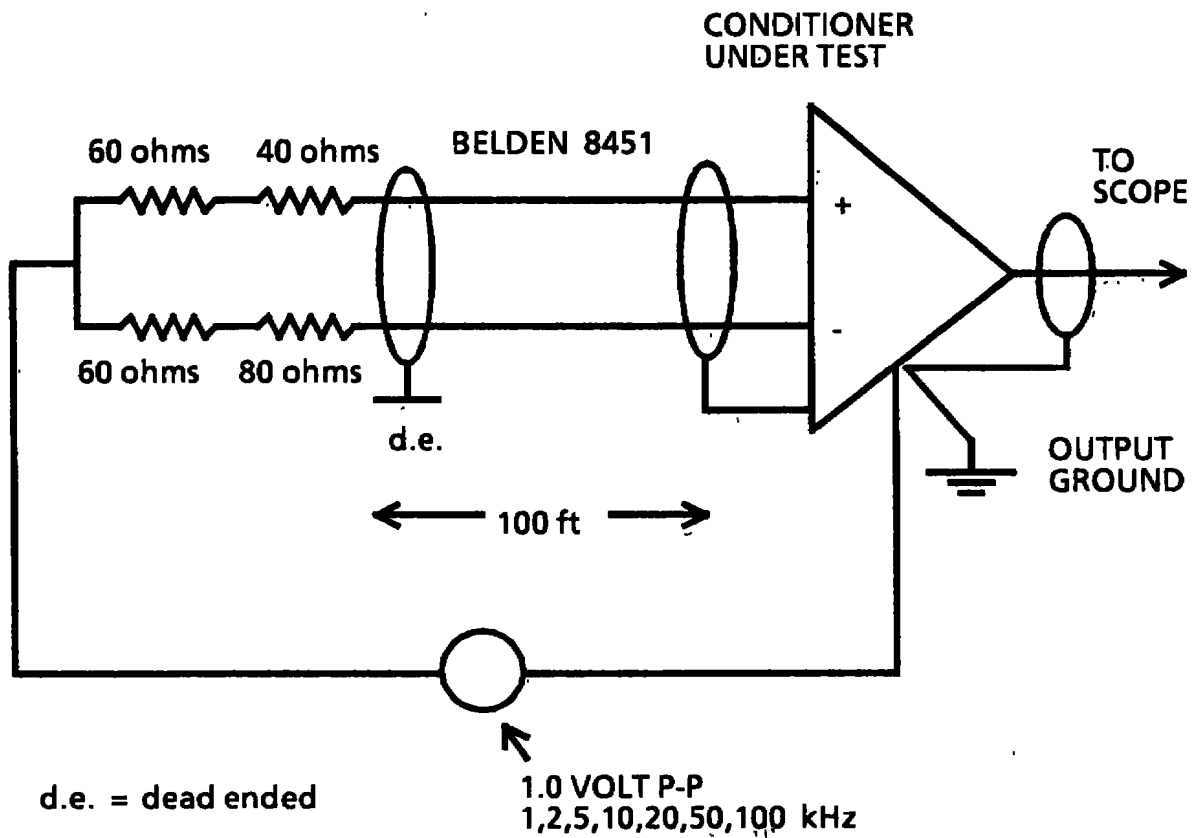

NOTES:

1. 80 kHz Filter In Conditioner
2. Cable is wrapped around a metal cylinder which is connected to output ground.

Figure 17. Measurement of Common-Mode Rejection.

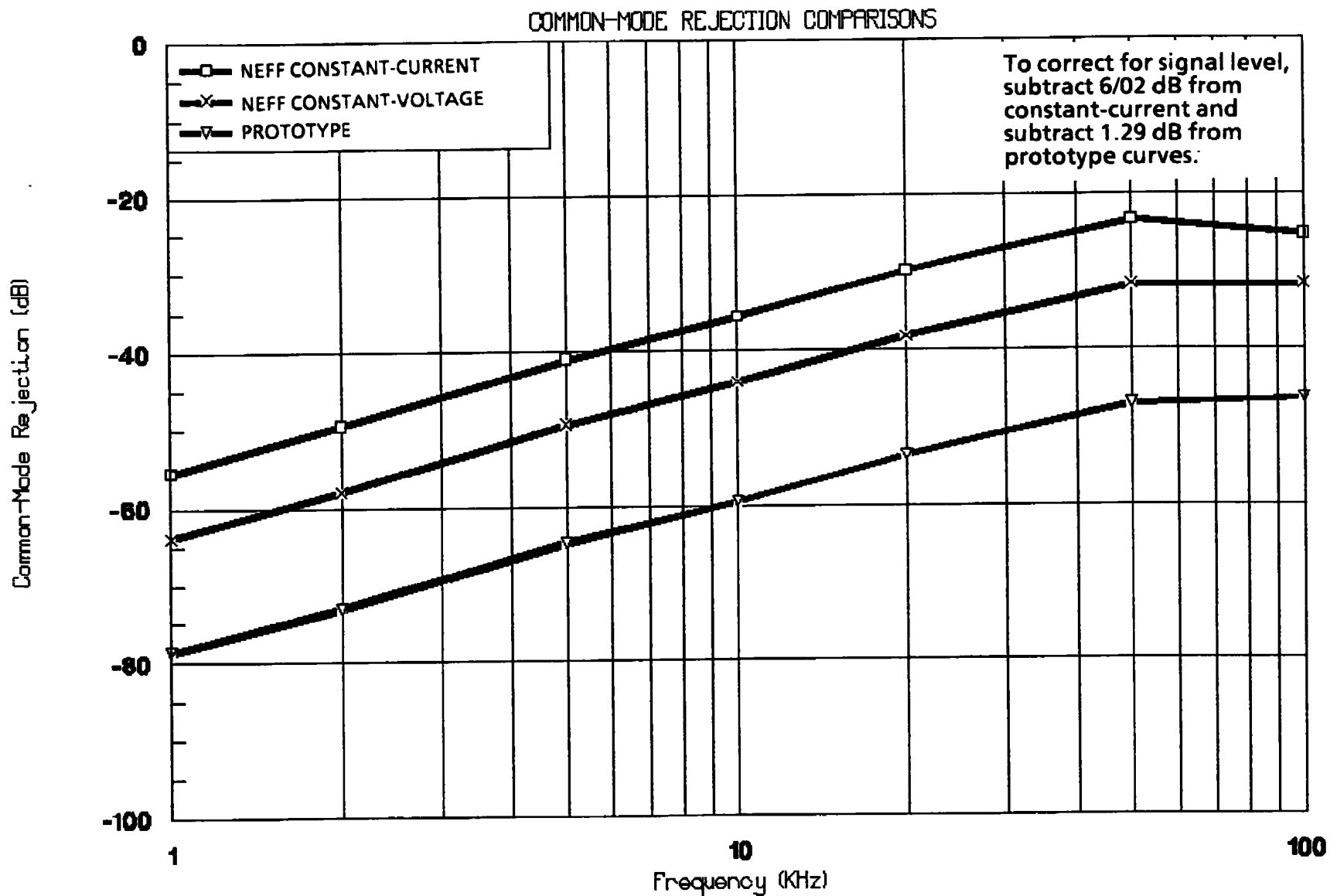

Figure 18. Common-Mode Rejection With Shield Floating at Sensor, Unbalanced Lead Resistances.

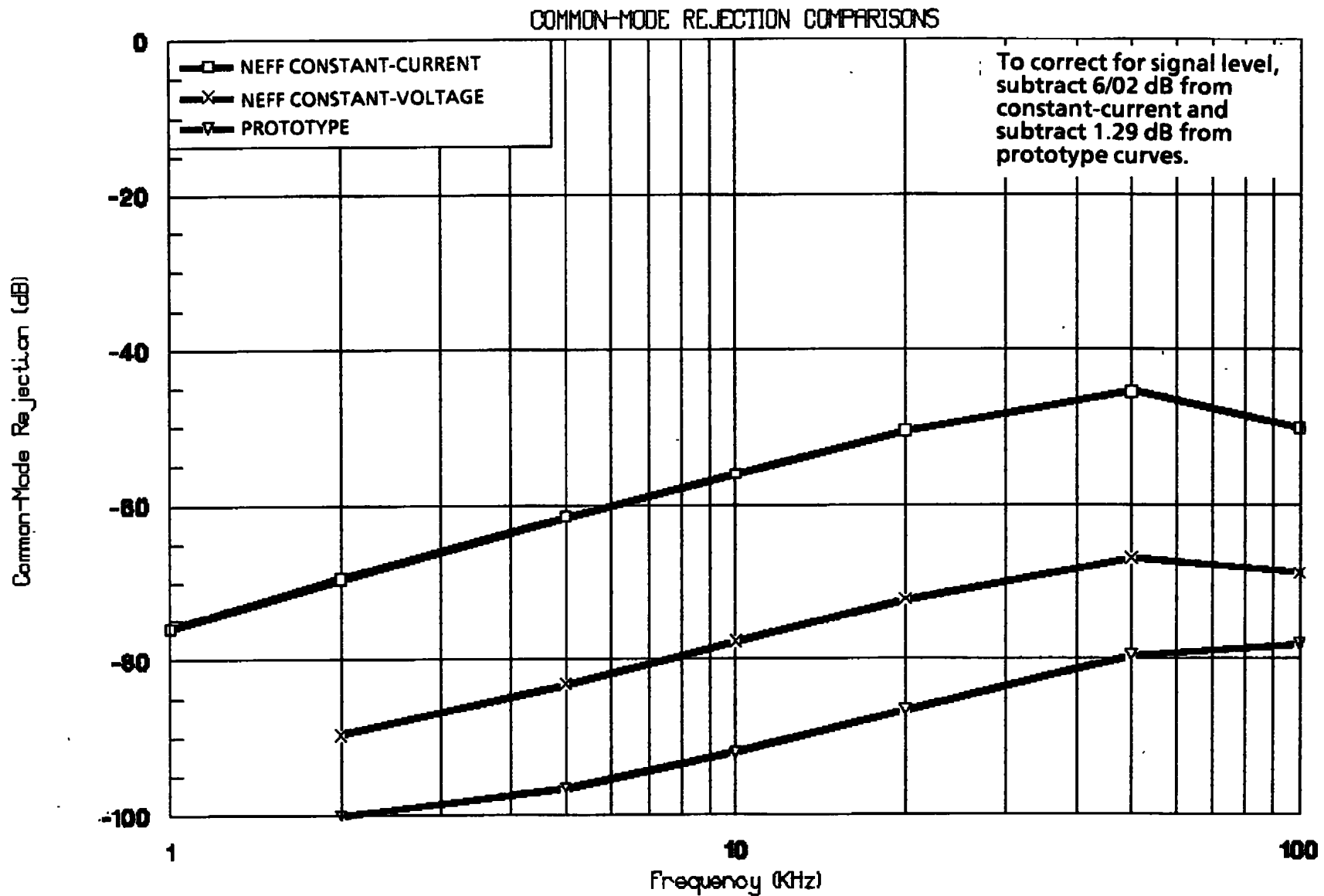

Figure 19. Common-Mode Rejection With Shield Tied to Common Mode at Sensor, Unbalanced Lead Resistances.

COMMON-MODE REJECTION COMPARISONS

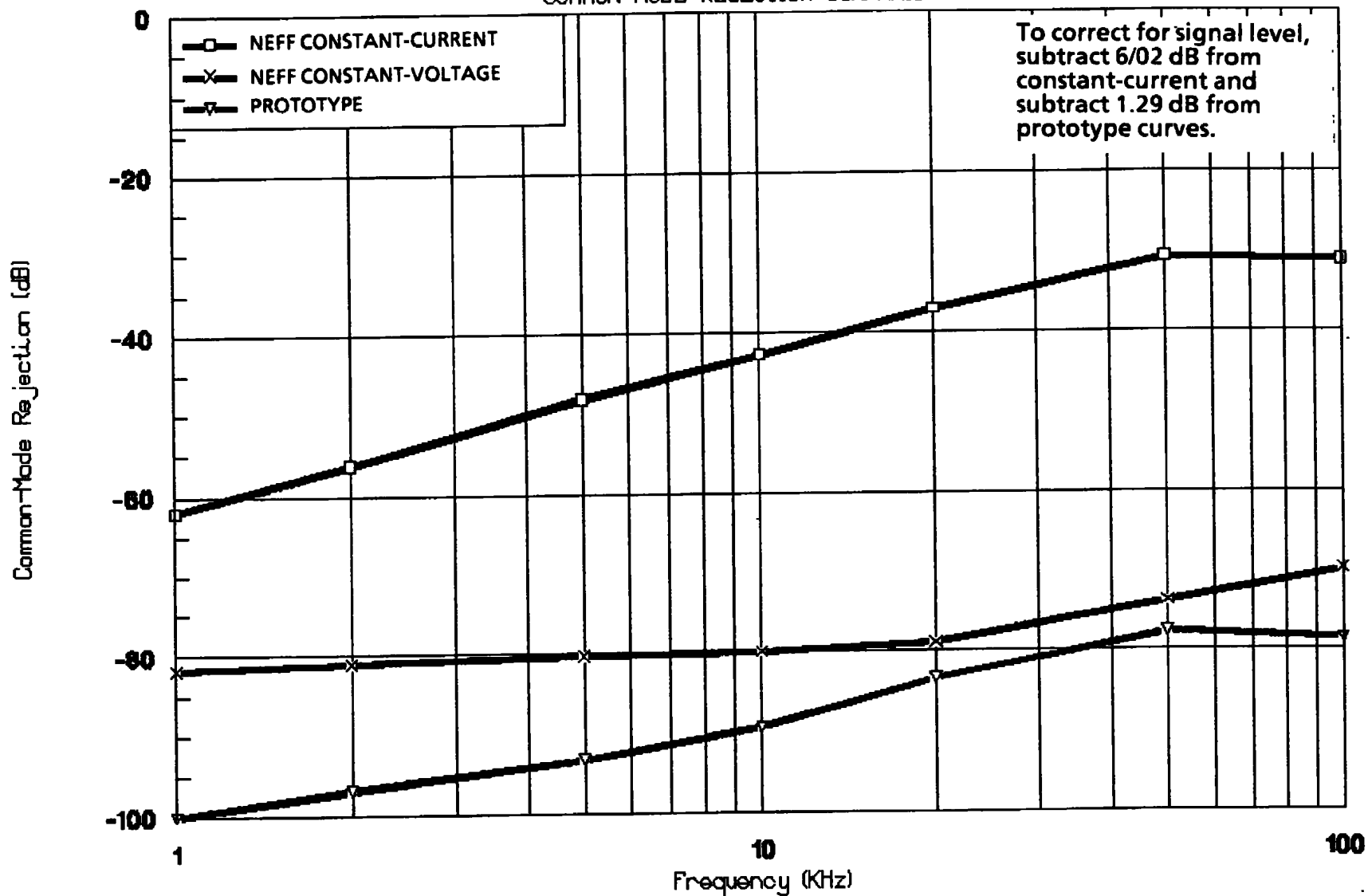

Figure 20. Common-Mode Rejection With Shield Floating at Sensor, Balanced Lead Resistances.

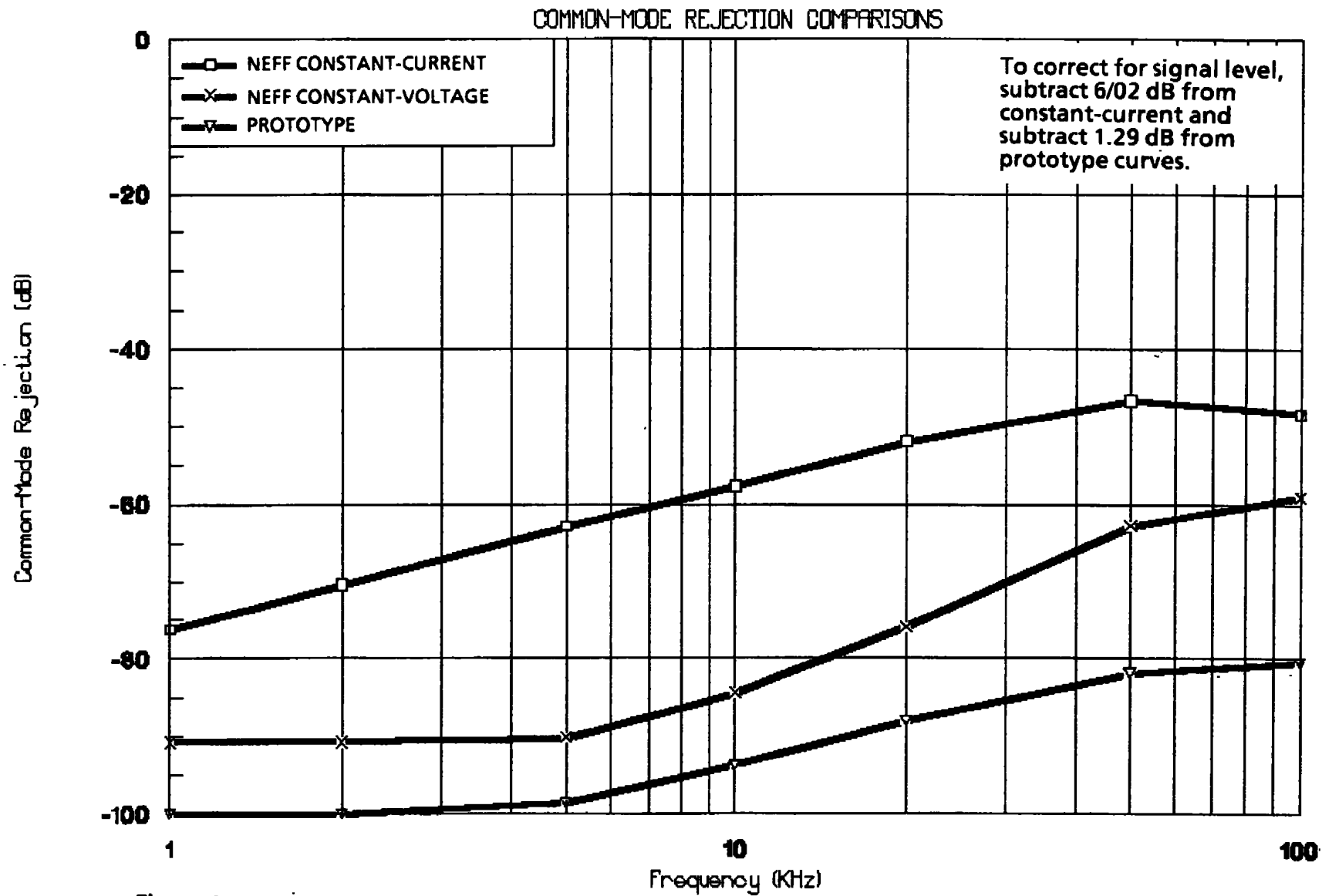
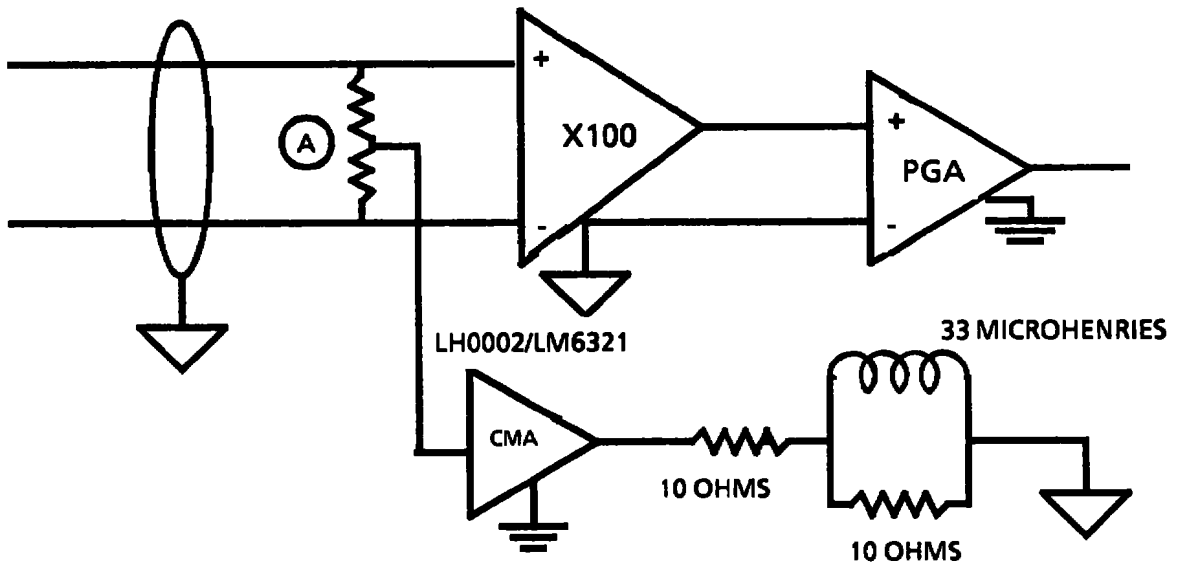

Figure 21. Common-Mode Rejection With Shield Tied to Common-Mode at Sensor, Balanced Lead Resistances.



Notes

1. Point A is location of excitation supply.
2. Common-mode amplifier drives cable shield, input stage power supply common, guard shield around input stage and guard shields on transformer windings for excitation supply and input stage power.
3. Network in common-mode amplifier output determined experimentally.

Figure 22. Circuit for Driving Cable Shield and Guard with Common-mode.

COMMON-MODE REJECTION COMPARISONS

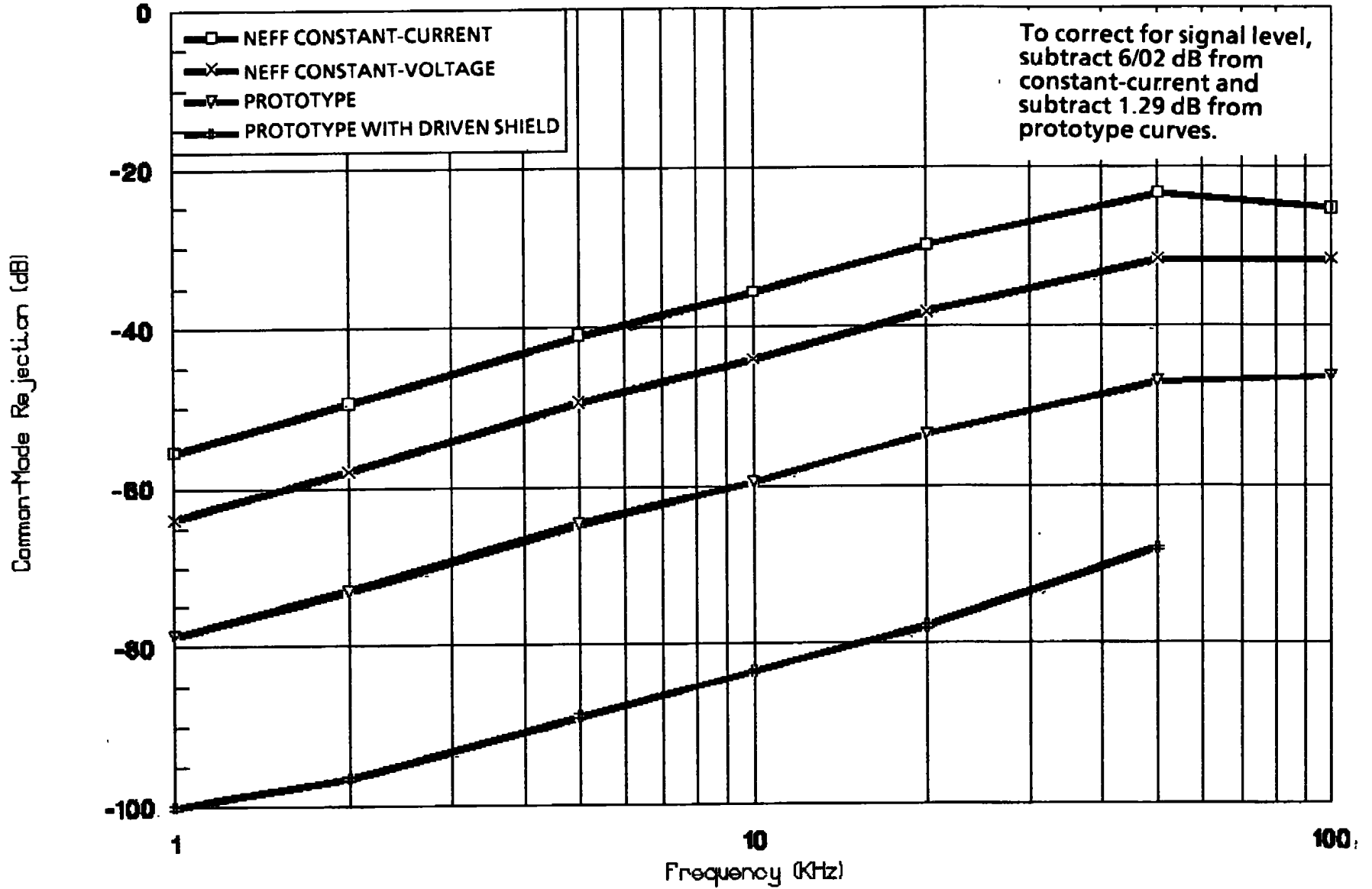
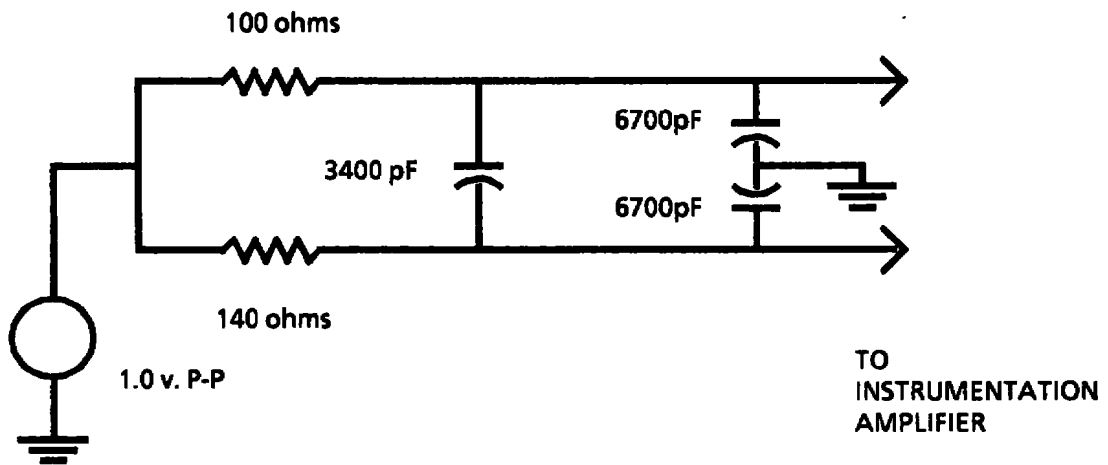

Figure 23. Improvement in Common-Mode Rejection With Driven Shield.

TABLE 1. Common-Mode To Normal-Mode Conversion For Circuit Shown



| Frequency | Normal Mode Signal |
|-----------|--------------------|
| 100 Hz | 0.261 mv P-P |
| 1 kHz | 1.693 mv P-P |
| 10 kHz | 16.699 mv P-P |
| 100 kHz | 104.918 mv P-P |

TABLE 2. Regulation Accuracy

| Lead Resistance, ohms | Voltage across Gage, volts | Current thru Gage, milliamperes |
|------------------------------|-----------------------------------|--|
| 0 | 3.5855 | 29.879 |
| 20 | 3.5854 | 29.878 |
| 40 | 3.5853 | 29.878 |
| 60 | 3.5852 | 29.877 |
| 80 | 3.5849 | 29.874 |
| 100 | 3.5838 | 29.865 |

TABLE 3. Internal Noise

| Constant Resistance F.S. = 4.35 mv | | Neff SCA Constant-Voltage F.S. = 3.75 mv | | Neff SCA Constant-Current F.S. = 7.5 mv | |
|---------------------------------------|--------------------|---|--------------------|--|--------------------|
| RTI | Percent Full Scale | RTI | Percent Full Scale | RTI | Percent Full Scale |
| 41 μ v P-P | 0.95% | 35 μ v P-P | 0.94% | 139 μ v P-P | 1.85% |

Notes:

1. RTI is noise at conditioner output divided by gain of amplifier.
2. Bandwidth of amplifiers is 80 kHz. Neff has a 6-pole Bessel LP filter and prototype constant-resistance has 4-pole Bessel.
3. F. S. assumes a 0.25 ohm change in a 120 ohm gage.

Table 4. Transient Common-Mode Rejection

| Input Pulse Width - μ s | Constant Resistance F.S. = 4.35 mv | | NEFF SCA Constant-Voltage F.S. = 3.75 mv | | NEFF SCA Constant-Current F.S. = 7.5 mv | |
|-----------------------------|---------------------------------------|--------------------|---|--------------------|--|--------------------|
| | RTI | Percent Full Scale | RTI | Percent Full Scale | RTI | Percent Full Scale |
| 0.5 | 0.170 mv P-P | 4% | 1.156 mv P-P | 31% | 3.574 mv P-P | 95% |
| 1.0 | 0.239 mv P-P | 8% | 2.383 mv P-P | 64% | 9.297 mv P-P | 248% |
| 2.0 | 0.652 mv P-P | 15% | 4.355 mv P-P | 116% | 12.578 mv P-P | 335% |
| 5.0 | 1.112 mv P-P | 26% | 7.461 mv P-P | 200% | 24.375 mv P-P | 650% |
| ≥ 10 | 1.181 mv P-P | 27% | 7.734 mv P-P | 206% | 26.250 mv P-P | 700% |

Notes:

1. Values given are the peak-to-peak signal resulting from a 0.5 volt positive input pulse of width shown. RTI is signal at conditioner output divided by gain of amplifier.
2. Input configuration of Fig. 16.
3. 80 kHz LP filter in conditioners.