



EFFECTS OF CYCLIC PREFIX JAMMING
VERSUS NOISE JAMMING IN OFDM SIGNALS

THESIS

Amber L. Scott, Second Lieutenant, USAF

AFIT/GE/ENG/11-35

DEPARTMENT OF THE AIR FORCE
AIR UNIVERSITY

AIR FORCE INSTITUTE OF TECHNOLOGY

Wright-Patterson Air Force Base, Ohio

APPROVED FOR PUBLIC RELEASE; DISTRIBUTION UNLIMITED.

The views expressed in this thesis are those of the author and do not reflect the official policy or position of the United States Air Force, Department of Defense, or the United States Government. This material is declared a work of the U.S. Government and is not subject to copyright protection in the United States.

AFIT/GE/ENG/11-35

EFFECTS OF CYCLIC PREFIX JAMMING
VERSUS NOISE JAMMING IN OFDM SIGNALS

THESIS

Presented to the Faculty

Department of Electrical and Computer Engineering

Graduate School of Engineering and Management

Air Force Institute of Technology

Air University

Air Education and Training Command

In Partial Fulfillment of the Requirements for the
Degree of Master of Science in Electrical Engineering

Amber L. Scott, M.A.S.

Second Lieutenant, USAF

March 2011

APPROVED FOR PUBLIC RELEASE; DISTRIBUTION UNLIMITED.

EFFECTS OF CYCLIC PREFIX JAMMING
VERSUS NOISE JAMMING IN OFDM SIGNALS

Amber L. Scott, M.A.S.
Second Lieutenant, USAF

Approved:

/signed/

7 Mar 2011

Dr. R.K. Martin, PhD (Chairman)

date

/signed/

7 Mar 2011

Maj. R.W. Thomas, PhD (Member)

date

/signed/

7 Mar 2011

Maj. M.D. Silvius, PhD (Member)

date

Abstract

Signal jamming of an orthogonal frequency-division multiplexing (OFDM) signal is simulated in MATLAB. Two different means of jamming are used to see, which is a more efficient way to disrupt a signal using the same signal power. The first way is a basic additive white Gaussian noise (AWGN) jammer that equally jams the entire signal. The second way is an AWGN jammer that targets only the cyclic prefix (CP) of the signal. These two methods of jamming are simulated using different channel models and unknowns to get varying results.

The three channel models used in the simulations are the no channel case, the simple multipath case, and the fading multipath case. The general trend shows that as the channel model becomes more complex, the difference in the effectiveness of each jamming technique becomes less.

The unknown in this research is the symbol-time delay. Since OFDM signals are characterized by multipath reception, the signal arrives at a symbol-time delay which is known or unknown to the jamming signal and the receiver. Realistically, the symbol-time delay is unknown to each and in that case, a Maximum Likelihood (ML) Estimator is used to find the estimated symbol-time delay. This research simulates the symbol-time delay as a known and an unknown at the jammer and receiver. The general trend shows that jamming the cyclic prefix is more effective than noise jamming when the symbol-time delay is unknown to the receiver. Sometimes this trend does not hold true, but further details are available in Ch. IV.

Acknowledgements

There are many people who helped me throughout my graduate program and deserve my thanks. I thank my lab friends for getting me through the stress and helping me with any questions I had (on LaTeX formatting specifically). They were always there to listen to my stories about school and home life and they were there to support me when I needed a helping hand. I thank my fiancé for supporting me this entire time and understanding that graduate work had to come first sometimes. I also thank him for picking up the slack in the other areas of my life when everything seemed to come at me all at once. Lastly, I thank my advisor, Dr. Martin, for being so helpful with my work and pointing me in the right direction. I also thank him for being very understanding of my unexpected priorities. That alone put me at ease and helped me get all of my work done on time to graduate. Thank you all!

Amber L. Scott

Table of Contents

	Page
Abstract	iv
Acknowledgements	v
List of Figures	viii
List of Tables	x
I. Introduction	1
1.1 Background	1
1.2 Motivation	3
1.3 Goals	4
1.4 Assumptions	4
II. Background	6
2.1 Jamming Background	6
2.1.1 Communications Versus Radar Versus Navigation Jamming	6
2.1.2 Cover Versus Deceptive Jamming	7
2.1.3 Self-Protection Versus Stand-Off Jamming	8
2.1.4 Decoys Versus Classical Jamming	8
2.2 OFDM on Interference	8
2.3 LTE on Interference	9
2.4 Related Work	10
III. Methodology	12
3.1 The OFDM System Model	12
3.2 Maximum Likelihood Estimation	14
3.3 Channel Conditions	18
3.4 Jamming Signal	19
3.5 The Receiver	20
IV. Results	23
4.1 Simulations	23
4.2 Results	24
4.2.1 Simulation 1	24
4.2.2 Simulation 2	25
4.2.3 Simulation 3	25
4.2.4 Simulation 4	27

	Page
4.2.5 Simulation 5	29
4.2.6 Simulation 6	29
4.2.7 Simulation 7	31
4.2.8 Simulation 8	33
4.2.9 Simulation 9	36
4.2.10 Simulation 10	36
4.2.11 Simulation 11	38
4.2.12 Simulation 12	38
4.3 Comparison	39
V. Conclusions	44
5.1 Conclusion	44
5.2 Future Work	44
5.2.1 Maximum Likelihood Estimator	44
5.2.2 Jamming Techniques	45
5.2.3 Signal Types	45
Bibliography	46

List of Figures

Figure		Page
1.1.	Multipath fading	2
1.2.	Cyclic prefix versus noise jamming	5
2.1.	Basic jamming technique	7
2.2.	Frequency hopping	10
3.1.	OFDM System	12
3.2.	OFDM Signal	13
3.3.	Insert CP	14
3.4.	Correlation for ML Estimation	16
3.5.	ML Est. Observation Interval	16
3.6.	Jamming Signal System	19
3.7.	All-jammer	20
3.8.	CP-jammer	21
3.9.	Receiver System	22
4.1.	BER: Simulation 1	26
4.2.	BER: Simulation 2	26
4.3.	RMSE: Simulation 2	27
4.4.	BER: Simulation 3	28
4.5.	RMSE, Jammer: Simulation 3	28
4.6.	BER: Simulation 4	29
4.7.	RMSE, Jammer: Simulation 4	30
4.8.	RMSE, Receiver: Simulation 4	30
4.9.	BER: Simulation 5	31
4.10.	BER: Simulation 6	32
4.11.	RMSE: Simulation 6	32
4.12.	BER: Simulation 7	33

Figure		Page
4.13.	RMSE: Simulation 7	34
4.14.	BER: Simulation 8	34
4.15.	RMSE: Simulation 8	35
4.16.	RMSE: Simulation 8	35
4.17.	BER: Simulation 9	36
4.18.	BER: Simulation 10	37
4.19.	RMSE: Simulation 10	37
4.20.	BER: Simulation 11	38
4.21.	RMSE: Simulation 11	39
4.22.	BER: Simulation 12	40
4.23.	RMSE: Simulation 12	40
4.24.	RMSE: Simulation 12	41
4.25.	BER Bar Plot: SNR = 10dB, SIR = 10dB	42
4.26.	BER Bar Plot: SNR = 10dB, SIR = 20dB	42
4.27.	RMSE vs BER, SNR = 10 dB	43

List of Tables

Table		Page
4.1.	Simulations	25

EFFECTS OF CYCLIC PREFIX JAMMING VERSUS NOISE JAMMING IN OFDM SIGNALS

I. Introduction

This chapter provides the basis for researching the effects of cyclic prefix jamming versus noise jamming in OFDM signals. This chapter begins with a background discussion of OFDM, followed by the motivation, goals, and assumptions made in this research.

1.1 Background

Over the past few years, OFDM systems have gained increased interest as a means for broadband multimedia mobile communication systems. The mobile radio channel is characterized by multipath reception, which means the receiving signal contains the direct line-of-sight (LOS) radio wave as well as a number of reflected radio waves that arrive at different times, Fig. 1.1. To overcome multipath-fading environments, OFDM transmission scheme, which is a parallel-data transmission scheme, is used [1].

OFDM is a case of multicarrier transmissions, where a single data stream is transmitted over a number of lower-rate subcarriers. In a single-carrier system, a single interferer can cause the entire link to fail, but in a multicarrier system, a small percentage of the subcarriers will be affected. In an OFDM system, the total signal frequency band is divided into N overlapping frequency subchannels, each being mathematically orthogonal to the next to avoid adjacent carrier interference. The OFDM system also uses a CP, which refers to the prefixing of a symbol with a repetition of the end. This serves as a guard interval, which eliminates the interference from the previous symbol and allows for simple frequency-domain processing, which is used for channel estimation [1]. Further details are provided in Ch. III.

The OFDM transmission scheme has many advantages [1]:

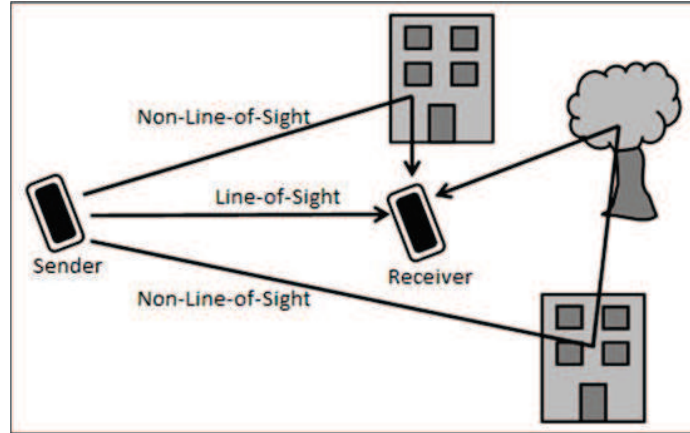

Figure 1.1: A visualization of multipath fading

- OFDM efficiently deals with multipath. The implementation complexity for a given delay spread is significantly lower than a single-carrier system with an equalizer.
- The data transfer rate can be scaled by adapting the data rate per subcarrier according to the signal-to-noise ratio (SNR) of that subcarrier.
- OFDM is robust against narrowband interference because only a small percentage of subcarriers are affected.

There are also disadvantages [1]:

- OFDM is sensitive to frequency offset and phase noise.
- OFDM has a large peak-to-average-power ratio, which tends to reduce power efficiency of the radio frequency amplifier.

OFDM technology is present in many systems that most people use today. It is used in digital audio and digital video broadcasting and such technology is even found in the Bluetooth technology used in something as common as videogame controllers. It is now a more universally-accepted standard for mobile radio and supports the Universal Terrestrial Radio Access Network Long Term Evolution (LTE), (4G technology), which provides a flexible and efficient use of different carrier bandwidths along with tolerance to noise and multipath interference [2], [3].

1.2 *Motivation*

Gaining a better understanding of OFDM technology is the focus of many interests, including manufacturing, communications, and the government agencies. Verizon Wireless talks about how 4G LTE technology is 10 times faster than 3G technology and reduces delay and buffering. This technology is backed by the foundation of OFDM technology and is now an integral part of many people's lives [4]. The U.S. Air Force seeks full spectrum dominance over any and all computers. The Broad Agency Announcement from Air Force Research Laboratory has announced their desire to support various scientific studies and experiments to better their knowledge of the broad range of capabilities required in support of dominant cyber offensive engagement and supporting technology. One of their objectives includes the capability to provide techniques and technologies to be able to affect computer information systems through deceive, deny, disrupt, degrade, and destroy (D5) effects [5]. The D5 describe the broad focus behind signal jamming technologies.

This thesis presents the investigation of jamming simulated OFDM signals. There are many methods of jamming. Some of these include:

- Noise jamming: this technique directs a noise signal to fill the entire band that the sender is using in order to interfere with the transmission.
- Sense jamming: this technique “senses” when the sender's signal is in a specific channel, then fills only the channel in use with noise.
- Deceptive jamming: this technique records the signals between the sender and receiver in order to send out similar signals to “confuse” the receiver.
- Selective jamming: this technique detects a specific transmission in the pool of signals and jams only that transmission.

This research, however, investigates two different jamming methods in the time-domain, noise jamming and a variation of noise jamming, CP-jamming. CP-jamming sends noise signals to only the cyclic prefix of each symbol in a given signal with

the desire of skewing the symbol-time delay correction at the receiver. These two techniques are tested in three different channel conditions and the effectiveness of each technique is compared by using bit error rate (BER) plots.

OFDM systems have become a basis for wireless communications as well as other applications and research has focused on the analysis and implementation of OFDM to better fortify existing systems. With so many systems integrating OFDM concepts, it is only natural to try to find a way to most effectively interfere or break those systems. This research is a foundation for jamming OFDM systems and it starts by researching the effects of two methods of jamming a simple OFDM signal.

1.3 Goals

This research takes a better look at the effects of jamming the CP of an OFDM signal against the traditional noise jamming technique, Fig. 1.2. The comparison is made in multiple channel conditions to gain a better insight to which technique works best in varying environments. The theory behind jamming the CP is simple. Since the CP is used as a means to correct the symbol-time delay and the carrier frequency offset of the signal by correlating the repeated parts of a symbol, using a more concentrated interfering signal in just the CP will throw off the correlation therefore disrupting the received signal. BER plots are used to compare the jamming techniques. The comparison shows whether or not estimating where all the CPs are located in the given signal and then jamming that part of the signal is more effective than sending a noise signal that disperses its interfering signal power across the entire signal. More detail is provided in Ch. III. The results are conclusive but are based on the assumptions and simulations of this research.

1.4 Assumptions

For this research, the following assumptions are made:

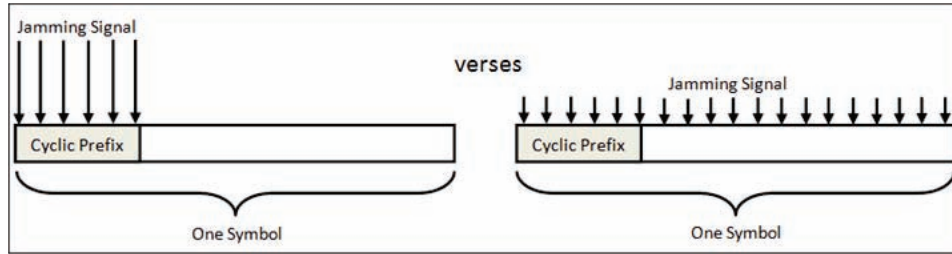

Figure 1.2: Cyclic prefix jamming (left) versus noise jamming model (right)

- The symbol-time delay for each symbol that is simulated is a constant; this is to simplify finding the root mean squared error of the symbol-time delay estimator.
- There is no frequency offset; this is to simplify the simulation and to be considered for future research.
- The signal power of the noise jammer is the same as the CP-jammer; this is to more accurately compare the techniques against each other.
- This simulation does not account for the sender changing channels in order to avoid interference; this is to simplify the simulation and to be considered for future research.
- The multipath, if present, is time-invariant, and its delay spread is less than the CP length.
- The jammer knows the physical locations of all devices so that it can account for all time delays.

II. Background

This chapter provides the background for the topics involved in this research. First, there is an overview of general information on jamming and how OFDM and LTE systems cope with interference.

2.1 Jamming Background

The purpose of all jamming is to interfere with another's ability to transmit information from one point to another [6]. The basic technique of jamming is to transmit an interfering signal along with the desired signal, Fig. 2.1.

Jamming is effective when the interfering signal is strong enough to prevent the receiver from recovering the required information from the desired signal. This is either because the information content in the desired signal is overwhelmed by the power of the jamming signal or because the combined signals have characteristics that prevent a processor from properly extracting the desired information [6]. Although this research looks at jamming from a communication standpoint, jamming is typically in conjunction with radar systems and is classified by the following:

- Type of signal (i.e. communication versus radar versus navigation)
- The way it attacks the jammed receiver (i.e. cover versus deception)
- Jamming geometry (i.e. self-protection versus stand-off)
- The way it protects friendly assets (decoy versus classical jammer)

2.1.1 Communications Versus Radar Versus Navigation Jamming. Communications jamming is the jamming of communications signals, which means a jammer sends an interfering signal to the receiver at the same time the transmitter sends its signal. This is done with the desire to reduce the quality of the desired information to an unusable level [6].

Radar has both a transmitter and receiver. The receiver is designed to receive return signals from objects illuminated by the transmitter. The radar determines the

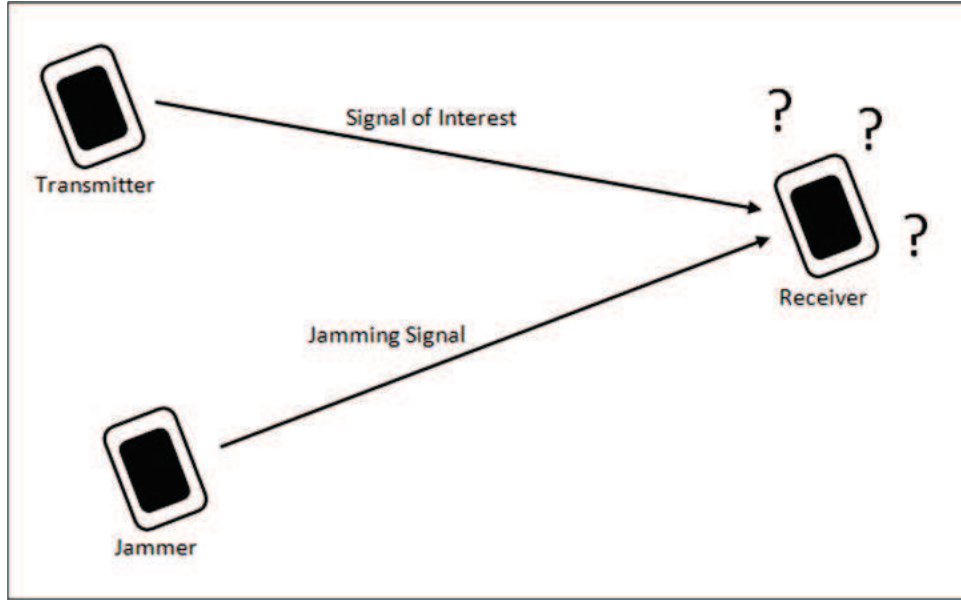

Figure 2.1: Jammer sends interfering signal at the same time as the transmitter

location and velocity of its target by analyzing the return signals. The radar jammer provides a cover or deceptive signal to prevent the radar from finding or tracking its target [6].

Navigation jamming is the jamming of systems such as the global positioning system (GPS). The purpose of GPS signal jamming is to prevent GPS loggers from either receiving satellite signals or sending signals back to their base station. This is done by the jammer sending out a noisy interfering signal on the same frequency as the GPS unit, therefore preventing the GPS from receiving or transmitting any information [7].

2.1.2 Cover Versus Deceptive Jamming. Cover jamming is the transmission of high-power signals into another's transmitter, which reduces the SNR to the point where the desired signal cannot be received with enough quality. In terms of radar, cover jamming hides the radar's return signal from the receiver [6].

Deceptive jamming causes the receiver to draw the wrong conclusions from the combination of its desired signal and the jamming signal. In radar, this jamming tech-

nique gets an apparently valid signal and is tricked into tracking a non-existent/false target [6].

2.1.3 Self-Protection Versus Stand-Off Jamming. Self-protection jamming is when the platform being detected or tracked transmits its own jamming signals. Stand-off jamming is when a jammer on one platform transmits jamming signals to protect another platform [6].

2.1.4 Decoys Versus Classical Jamming. A decoy is a different kind of jammer designed to look like a protected platform rather than the protected platform itself. The difference between decoys and classical jammers is that a decoy does not interfere with the radars tracking it. Instead, it seeks to attract the attention of those radars, transferring the focus from the actual target [6].

This research specifically looks at communication jamming and is a basis for future work in cognitive communications jamming.

2.2 OFDM on Interference

OFDM and LTE systems are designed in a way to efficiently have successful communication transmissions and to be able to cope with interference, intentional or not.

As described in Ch. I, OFDM transmits signals using a large number of closely spaced subcarriers that are modulated at a low data rate. By making the signals orthogonal to each other, there is no mutual interference. The data transmitted is split across all the subcarriers and because only some of the subcarriers are lost due to multipath effects, error correcting techniques can reconstruct the data. Additionally, inserting a cyclic prefix, a copy of the last part of each symbol, to the front of each symbol helps overcome inter-symbol interference. Its length is selected to be larger than the maximum anticipated excess delay of the multipath propagation channel. Due to the cyclic prefix, the transmitted signal is periodic and the effect of the

time-dispersive multipath channel becomes equivalent to a cyclic convolution. The properties of the cyclic convolution allow the subcarriers to remain orthogonal [1]. A detailed model of OFDM is given in Ch. III. The basic concepts of OFDM are a foundation for LTE.

2.3 LTE on Interference

One key element of LTE is the use of OFDM as the signal bearer. One of the main reasons for using OFDM as a modulation format within LTE is its resilience to multipath delay spread, which can account for several microseconds. Moreover, the insertion of a CP adds to the resilience of the system and helps overcome inter-symbol interference [8], [9]. Both multipath delay spread and user equipment power consumption are important factors in the LTE design, thus LTE implements orthogonal frequency division multiple access (OFDMA) for downlink transmission and single-carrier frequency division multiple access (SC-FDMA) for uplink transmission [8].

The difference between OFDM and OFDMA is that OFDMA is a multi-user OFDM, which allows multiple access on the same channel. This is done by distributing the subcarriers among users so all users can transmit and receive at the same time. Further, subchannels are matched to each user to lessen fading and interference based on the location and propagation characteristics of each user, providing better transmission performance [10].

OFDMA has a high peak-to-average ratio, which is not a problem for a base station in the LTE downlink, but the high power consumption of OFDMA is not acceptable for mobile phones, where battery life is limited. SC-FDMA is a different access technique used in the LTE uplink. It is a single-carrier transmission scheme opposed to OFDMA, which is a multi-carrier transmission scheme. The LTE concept combines the low peak-to-average ratio offered by single-carrier systems with the multipath interference resilience and flexible subcarrier frequency allocation that OFDM provides [8].

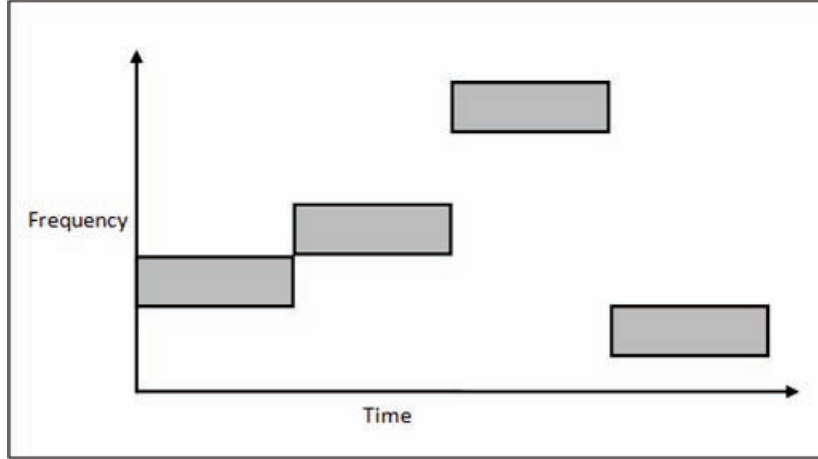

Figure 2.2: Frequency hopping over a time interval

Another technique the LTE system uses is frequency hopping, Fig. 2.2. In order to avoid staying on a bad fading channel for a long time, frequency hopping maps which subcarrier frequency the signal changes to, thus improving the communication performance. This mapping scheme uses a pseudorandom code, which is known by the transmitter and receiver to change the subcarrier frequency [11]. This technique further illustrates how the LTE system is robust against signal jamming.

2.4 Related Work

The basis of this research is to look at effects of partial-time jamming on OFDM signals compared to AWGN jamming. The specific details are explained in following chapters, but there are other research papers that also take a look at partial-time jamming from a different perspective. In [12], the authors consider a communication scenario in which a message is received in the presence of partial-time Gaussian jamming and additive white Gaussian noise. Although this problem relates when considering the jamming perspective, the authors are trying to find a better way to do channel estimation in the presence of partial-time jamming. Their problem compares the expectation-maximization (EM) algorithm versus a blind estimation algorithm with the following specifications:

- Binary phase-shift keying (BPSK) is used for modulation.

- The system is considered in a quasi-static channel, in which the amplitude and phase are constant over each packet transmission.
- The jammer is modeled using a two state Markov model. (When the jammer is in state 0, it does not transmit the jamming signal; when the jammer is in state 1, the jammer does transmit the jamming signal.)
- The receiver does not know the amplitude and phase of the incoming signal.
- The receiver does not know which symbols are jammed or the statistics of the jammer.
- The receiver must estimate the parameters of the channel and the jamming to achieve good performance.

In [13], the authors propose new collaborative reception techniques for use in the presence of a partial-time Gaussian jammer. Under their proposed techniques, a group of radios acts as a distributed antenna array by exchanging information that is used to perform jamming mitigation. Their jamming mitigation techniques offer a tradeoff between performance and complexity [13]. With modifications to the intent of the research, these two topics provide a foundation for comparing jamming techniques.

III. Methodology

This chapter introduces the features of the OFDM signal as well as the mathematical breakdown of the maximum likelihood symbol-time delay estimator. One of the problems in the design of OFDM receivers is the unknown symbol arrival time. Sensitivity to a time offset is higher in multicarrier systems than in single-carrier systems, which is why a ML estimator for the symbol-time delay is used [14].

3.1 The OFDM System Model

The baseband discrete-time OFDM system model is given in Fig. 3.1 and is used in the simulation. Blocks “Jamming Signal” and “Receiver” are explained in Sec. 3.4 and Sec. 3.5 respectively. The binary information is grouped and mapped according to 4-quadrature amplitude modulation (QAM). The QAM data symbols are modulated and demodulated, respectively by means of *inverse fast Fourier transform* (IFFT) and *fast Fourier transform* (FFT) on N -parallel subcarriers. Not all N subcarriers are used in this research. There are N_a active tones (subcarriers) used. The signal should occupy as little bandwidth as possible which introduces less amount of interference to the system on adjacent channels [1]. The IFFT block is used to transform the data sequence, \underline{X}_k , into time-domain signal, \underline{x}_k , Fig. 3.2, with the following equations:

$$\underline{x}_k = IFFT \{ \underline{X}_k \} \quad (3.1)$$

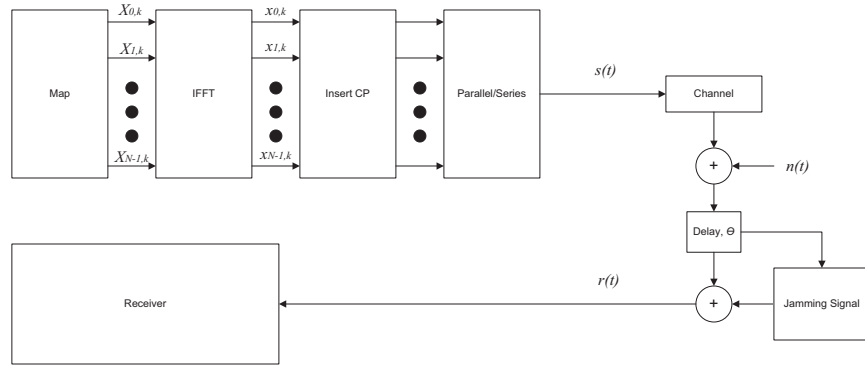

Figure 3.1: OFDM system block diagram

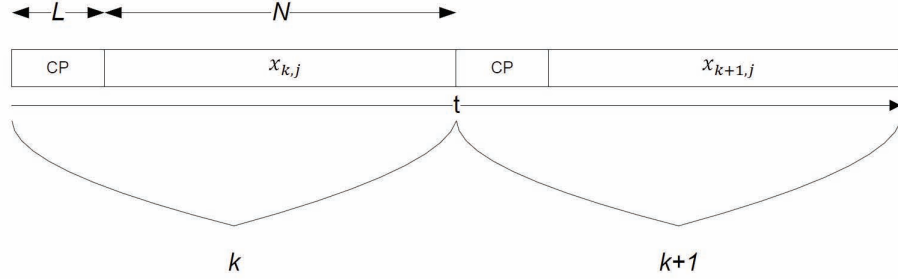

Figure 3.2: Structure of OFDM signal. Two OFDM symbols are represented.

$$x_{k,j} = \frac{1}{\sqrt{N}} \sum_{i=1}^N X_{k,i} e^{j \frac{2\pi}{N} ij} \quad (3.2)$$

These equations and Fig. 3.2 are associated with the following variables:

- i : Frequency index on subcarriers, $i \in \{0, 1, \dots, N - 1\}$
- k : Time index on transmitted symbol, $k \in \{0, 1, \dots, \infty\}$
- j : Index on samples within symbol, $j \in \{0, 1, \dots, N - 1\}$
- N : FFT length, in samples
- L : CP length, in samples
- M : $N + L$

Following the IFFT block, the cyclic prefix, which is the last L samples of the body of the OFDM symbol (N samples long) and chosen to be larger than the expected delay spread, is copied and inserted to prevent intersymbol interference and maintain orthogonality between the subcarriers. This forms the complete $L + N$ sample long OFDM symbol [1]. Fig. 3.3 gives a visual representation of how \underline{x}_k is organized into $s(t)$.

In the simulation, the transmitted signal $s(t)$ is tested in three different channel conditions, which is explained more in depth in Sec. 3.3 and is affected by complex AWGN, $n(t)$. This signal is then delayed by a constant symbol-time delay, θ , which is

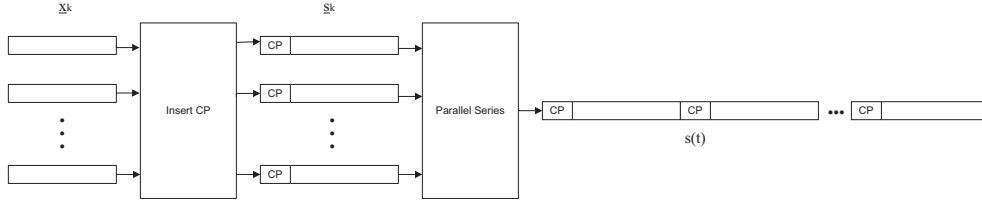

Figure 3.3: Representing how \underline{x}_k is organized into $s(t)$

assumed to be $0 \leq \theta < (N + L - 1)$, used throughout the entire analysis. The signal is next affected by an interfering signal, $jam(t)$. Two different methods of jamming are tested against each other. The first method is a basic AWGN jammer (All-jammer), which sends an interfering signal across the entire signal [1]. The second method is a form of AWGN jammer, which specifically targets the cyclic prefix of the OFDM signal (CP-jammer). This could also be looked at as a partial-time jammer or a periodic jammer. In order to make these two techniques comparable, the interfering signals power have equal average power. The jamming signals are first tested assuming the symbol-time delay, θ , is known to the jammer and the receiver. This ensures the cyclic prefix receives the full jamming effects of the interfering signal for the CP-jammer case. The jamming signals are then tested assuming the symbol-time delay is unknown to the jammer, demodulator, or both. This may allow some or all of the cyclic prefix to be altered due to the jamming signal, which may render the CP-jammer ineffective. The uncertainty in the delay requires the use of a maximum likelihood (ML) estimation of the symbol-time delay.

3.2 Maximum Likelihood Estimation

An uncertainty of the arrival time of the OFDM signal affects how efficiently the jammer and receiver properly function. There are two instances where maximum likelihood (ML) estimation of the symbol-time delay is used. The first is when the transmitted signal encounters a jamming signal. The ML estimator must work through the AWGN in order to find the symbol-time delay. Using this information, the jammer then sends a signal to interfere with the transmitted signal. The second

time the ML estimator is used is after the signal is received. The ML estimator must work through the AWGN and possibly the jamming signal in order to correct the symbol-time delay for demodulating. The following equation represents the symbol-time delay as well as AWGN and the jamming signal at the receiver.

$$r(t) = s(t - \theta) + n(t) + jam(t) \quad (3.3)$$

A ML estimation is calculated with an algorithm, which uses $(5N + 5L - 1)$ consecutive samples of the OFDM signal to estimate the symbol-time delay. These samples contain four complete $(N+L)$ -sample OFDM symbols (four blocks), which is used to estimate the position of the symbol-time delay, multi-block averaging. The authors from [14] use only one index set (one block) to correlate the information, but multi-block averaging allows more information, three more index sets of data in this simulation, to correlate over, which gives a more accurate estimation of the symbol-time delay. Define the index sets per block

$$I \equiv \{\theta, \dots, \theta + L - 1\} \quad (3.4)$$

$$I' \equiv \{\theta + N, \dots, \theta + N + L - 1\} \quad (3.5)$$

(see Fig. 3.5). The set I' contains the indices of the data samples that are copied into the cyclic prefix and the set I contains the indices of this prefix. This occurs in each symbol. Collect the observed samples in the $(5N + 5L - 1)$ times 1-vector $\mathbf{r} \equiv [r(1) \dots r(5N + 5L - 1)]^T$. The samples in the cyclic prefix and their copies are pair-wise correlated while the remaining samples are mutually uncorrelated. So the average of the correlation of the four blocks (which has four sets of the cyclic prefix and its copy) is taken for up to $(N + L - 1)$ delay. The delay which has the best correlation is the estimate for the symbol-time delay. Fig. 3.4 shows the best correlation as the sample index that has the highest amplitude. More blocks to correlate may allow a more accurate estimation, but this analysis uses four blocks.

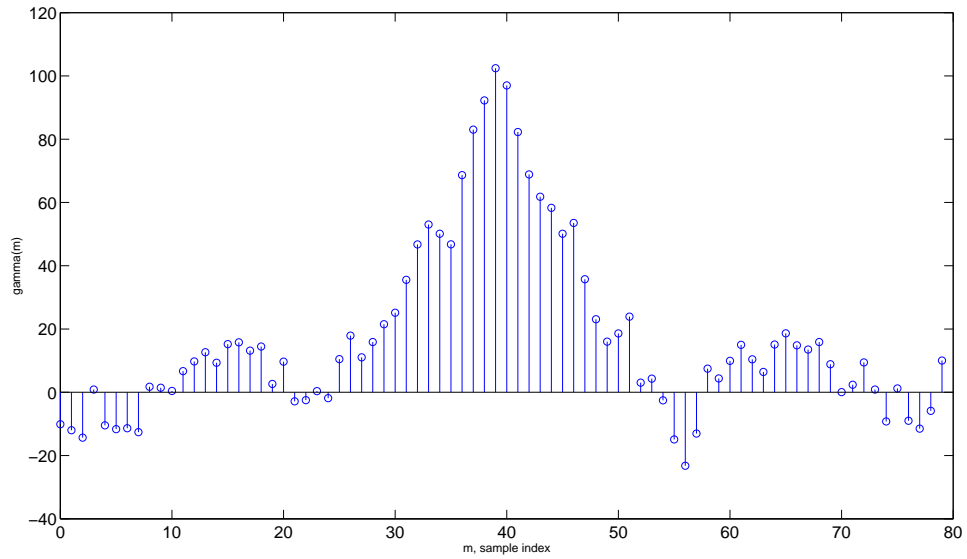

Figure 3.4: Correlation for ML estimation of the symbol-time delay

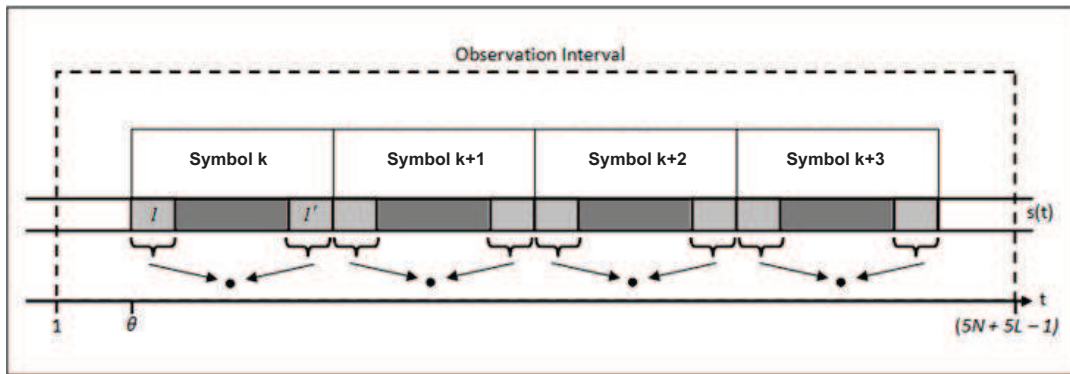

Figure 3.5: Observation interval shown within the structure of the OFDM signal for symbol-time delay ML estimation

The log-likelihood function for θ , $\Lambda(\theta)$, is the logarithm of the probability density function $\hat{f}(r)$ of the $(5N + 5L - 1)$ observed samples in \mathbf{r} given the arrival time, θ . Using the correlation properties of the observations \mathbf{r} , the log-likelihood function is written as

$$\Lambda(\theta) = \log f(\mathbf{r}|\theta) \quad (3.6)$$

$$= \log \Pi_{t \in I} f(r(t), r(t + N)) \Pi_{t \notin I \cup I'} f(r(t)) \quad (3.7)$$

$$= \log \Pi_{t \in I} \frac{f(r(t), r(t + N))}{f(r(t))f(r(t + N))} \Pi_{t \notin I} f(r(t)) \quad (3.8)$$

Under the assumption that \mathbf{r} is a jointly Gaussian vector, (3.8) is shown to be

$$\Lambda(\theta) = |\gamma(\theta)| \cos(\angle \gamma(\theta)) - \rho \Phi(\theta) \quad (3.9)$$

where \angle denotes the argument (angle) of a complex number and

$$\gamma(m) \equiv \sum_{b=1}^B \sum_{t=1}^L r(t + m + bM) r^*(N + t + m + bM), \quad (3.10)$$

$$\Phi(m) \equiv \sum_{b=1}^B \sum_{t=1}^L |r(t + m + bM)|^2 + |r(N + t + m + bM)|^2, \quad (3.11)$$

and

$$\rho = \frac{SNR}{SNR + 1} \quad (3.12)$$

where B is the number of blocks that are being correlated ($B = 4$) and m is the sample index the equation is correlating over. The ML estimate of θ is the argument maximizing $\Lambda(\theta)$.

$$\hat{\theta}_{ML} = \operatorname{argmax}_{\theta} \{|\gamma(\theta)| - \rho \Phi(\theta)\} \quad (3.13)$$

Eqs. (3.6)- (3.13) are from [14] simplified for no carrier frequency offset.

3.3 Channel Conditions

The simulation runs through three different finite impulse response (FIR) channel models to get a better look at the effects of jamming an OFDM signal. Each normalized channel has a length of $L - 1$ symbols, which is the same length as as the CP [15]. These are:

- No channel: this non-dispersive channel is used solely to test the effects of the jamming signals and the ML estimator without outside interference.

$$h = [1 \ 0 \ 0 \ 0 \ 0 \ 0 \ 0 \ 0 \ 0 \ 0 \ 0 \ 0 \ 0 \ 0 \ 0 \ 0]$$

- Simple multipath: this dispersive channel is used to test the effects of slight multipath.

$$h = [1 \ 0 \ 0 \ \alpha \ 0 \ 0 \ 0 \ 0 \ 0 \ 0 \ 0 \ 0 \ 0 \ 0 \ 0 \ 0]$$

where α is a value less than 1. In this research, $\alpha = 0.5$.

- Fading multipath: this dispersive channel is used to test the effects of really fading complex Gaussian multipath.

$$h = [1 \ 0 \ \alpha_1^2 \ 0 \ \alpha_2^2 \ 0 \ \alpha_3^2 \ 0 \ \alpha_4^2 \ 0 \ \alpha_5^2 \ 0 \ 0 \ 0 \ 0 \ 0]$$

where α_β^2 is a complex Gaussian random variable with standard deviation of α_β on each of its real and imaginary parts. In this research, $\alpha_1 = 0.5\mu$, $\alpha_2 = 0.3\mu$, $\alpha_3 = 0.1\mu$, $\alpha_4 = 0.4\mu$, and $\alpha_5 = 0.2\mu$, where μ is a random variable scaled by a constant.

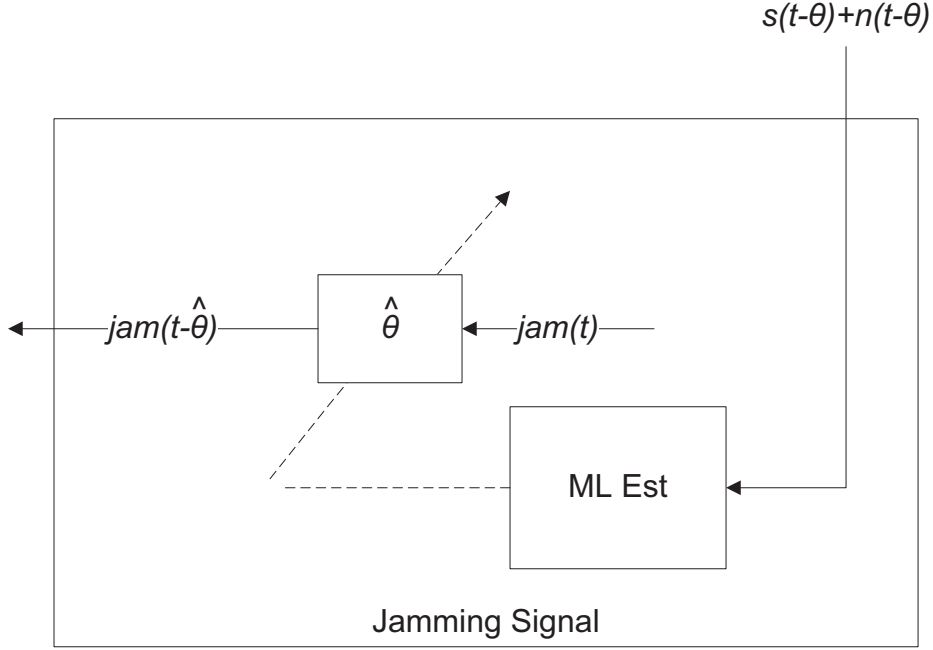

Figure 3.6: Jamming signal system block diagram from OFDM system block diagram (Fig. 3.1)

3.4 Jamming Signal

The “Jamming Signal” block from Fig. 3.1 is represented in Fig. 3.6. The signal entering the “Jamming Signal” block is the transmitted signal after AWGN is added and the entire signal is delayed by θ . As explained in Sec. 3.2, the “ML Est” block uses the signal to estimate the symbol-time delay, which is represented as a varying delay value. The jamming signal, $jam(t)$, uses the estimated value in order to line up with the transmitted signal to interfere with the transmission. So the signal exiting the “Jamming Signal” block is $jam(t)$ delayed by the symbol-time value given by the ML estimator.

The All-jammer, $jam(t)$, Fig. 3.7, is *AWGN* $N(0, \sigma_s^2)$, where σ_s^2 is scaled to produce the desired SIR.

$$SIR = \frac{\sigma_x^2}{\sigma_s^2} \tag{3.14}$$

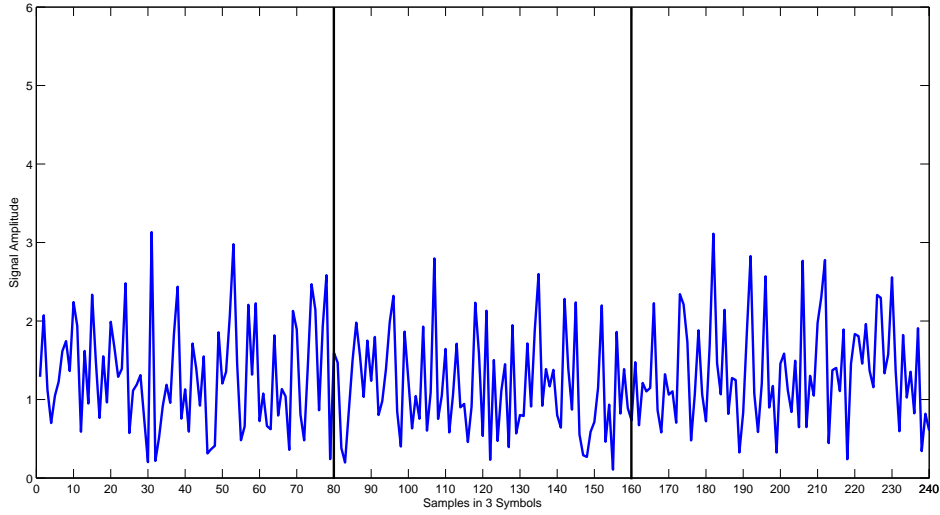

Figure 3.7: The All-jammer over 3 symbols

The CP-jammer, $jam(t)$, Fig. 3.8, is a partial time jammer where the signal only interferes with the CP of the OFDM symbol. The jamming signal per symbol is *AWGN* $N(0, \sigma_s^2)$, where the SIR is

$$SIR_{CP} = (N/L) \frac{\sigma_x^2}{\sigma_s^2} \quad (3.15)$$

So $jam(t)$ is a signal with *AWGN* described above occurring periodically for all CPs. The average power for the All-jammer and CP-jammer are the same.

3.5 The Receiver

The “Receiver” block from Fig. 3.1 is represented in Fig. 3.9. The signal enter the block is the received signal, which is the transmitted signal after *AWGN* is added, the entire signal is delayed by θ , and then $jam(t)$ is added. As explained in Sec. 3.2, the “ML Est” block uses the signal to estimate the symbol-time delay, which is represented as a varying delay value. The received signal, $r(t)$, uses the estimated value in order to correct the delay so there are fewer errors when the signal is demodulated. After the received signal corrects its symbol-time delay according to the ML estima-

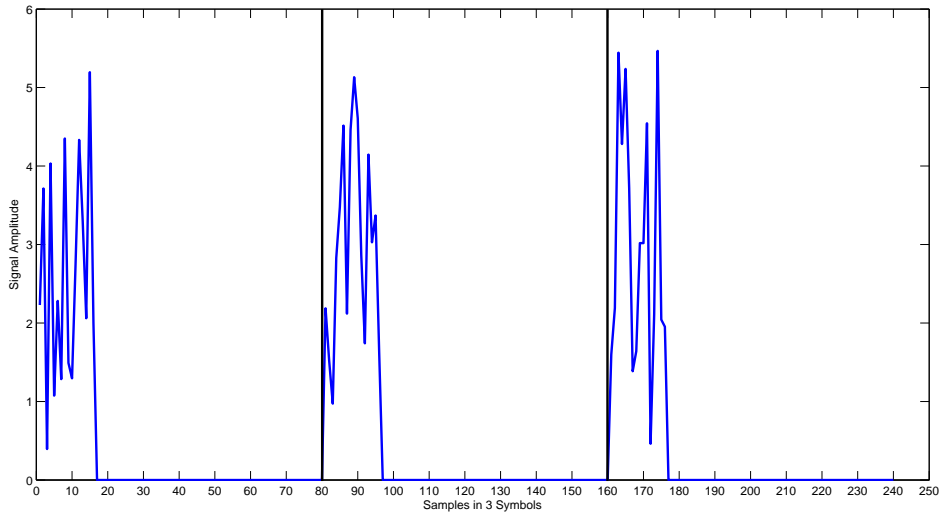

Figure 3.8: The CP-jammer over 3 symbols

tor, most of the “Receiver” block functions opposite as it started in the transmitter. However, the frequency domain equalizer (FEQ) is used after the *fast Fourier transform*. The FEQ is a way of inverting what is done at each individual subchannel at the transmitter and balancing the noise. With no noise, the zero-forcing FEQ at each subchannel is represented in the following [16].

$$FEQ_i \approx \frac{H_i^*}{H_i^* H_i} = \frac{1}{H_i} \quad (3.16)$$

With noise, the minimum mean squared error FEQ at each subchannel is represented as

$$FEQ_i \approx \frac{H_i^* \sigma_x^2}{H_i^* H_i \sigma_x^2 + \sigma_n^2} \quad (3.17)$$

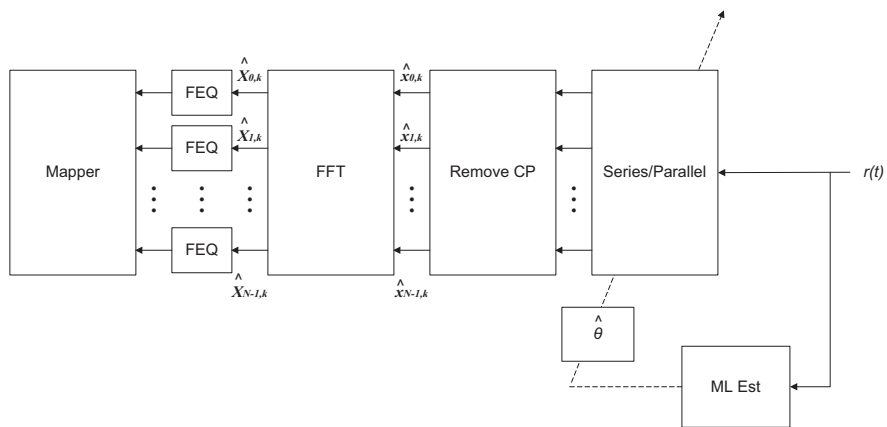

Figure 3.9: Receiver system block diagram from OFDM system block diagram (Fig. 3.1)

IV. Results

This chapter goes over the specifications of the simulations as well as the results and comparison of the simulations. The framework for the simulation code was adapted from the Matlab code used in [17], and an older version available at [18].

4.1 Simulations

An OFDM system with 64 subcarriers is simulated to evaluate the effectiveness of the All-jammer versus the CP-jammer. The simulation is run in three different channel conditions and with or without the use of the ML estimator at the jammer and receiver. In each simulation, 15 000 symbols are used, 100 symbols per signal (N_{sym}) with 150 (P) signal trials per simulation. Each symbol has 80 samples, 52×2 bits of QAM data. There are 52 active tones (N_a). The performance of each of the jamming signals is evaluated against each other by means of a bit error rate (BER) plot. The performance of the ML estimator, used in specific cases, is evaluated by means of a root mean squared error (RMSE) plot. Each simulation compares the case where there is no jamming, All-jamming, and CP-jamming at different signal-to-interference ratios (SIR). The SIR values evaluated are 0, 10, and 20 dB. Each case is also evaluated at signal-to-noise ratios (SNR) between 0 and 20 dB. BERs are calculated for each trial with

$$BER_p = \frac{\Delta}{2N_a(N_{sym})} \quad (4.1)$$

where Δ is the total number of bit errors in a signal, N_a is the number of active tones, and N_{sym} is the number of symbols in each signal. Eq. (4.1) accounts for the two bits per symbol. The BER of each trial in a given case is calculated. The average of the trials is represented as BER_{avg} . Error bars are determined for each BER plot and are calculated using Eq. (4.2). The error for BER is a Bernoulli random variable and is calculated with the following equations [19].

$$ErrorBar = \sqrt{\frac{BER_{avg} \cdot (1 - BER_{avg})}{P \cdot N \cdot N_{sym}}} \quad (4.2)$$

In order to gauge the performance of the ML estimator, the RMSE of the symbol-time delay estimator is averaged over P trials. The following equations are used:

$$Error_p = \theta_p - \hat{\theta}_p \quad (4.3)$$

$$RMSE = \sqrt{\frac{1}{P} \sum_{p=1}^P (Error_p)^2} \quad (4.4)$$

Since $var(sum) = sum(var)$ for independent random variables, the error bars on the sum of the errors is calculated using Eq. (4.5). The $\frac{1}{\sqrt{P}}$ is because the $\frac{1}{P}$ in the average decreases the variance by P and the standard deviation by \sqrt{P} . The standard deviation of $Error_p$ is represented as σ_{Error_p} . Error bars are determined for each RMSE plot.

$$ErrorBarRMSE = \frac{1}{\sqrt{P}} \cdot \sigma_{Error_p} \quad (4.5)$$

4.2 Results

The results are given with variations in channel conditions, use of the ML estimator at the demodulator, and use of the ML estimator at the jammer. The differences in each simulation is given in Tab. 4.1.

4.2.1 Simulation 1. The first channel case evaluated is having no channel. The symbol-time delay is known to the jamming signal and the demodulator. Fig. 4.1 shows the All-jammer as a more effective jamming signal compared to the CP-jammer. The CP-jammer is performing just like the no jamming case. This is expected because

Table 4.1: Simulation descriptions

Simulation	Channel	ML Est. at Demodulator	ML Est. at Jammer
1	No Channel Effects	No	No
2	No Channel Effects	Yes	No
3	No Channel Effects	No	Yes
4	No Channel Effects	Yes	Yes
5	Simple Multipath	No	No
6	Simple Multipath	Yes	No
7	Simple Multipath	No	Yes
8	Simple Multipath	Yes	Yes
9	Fading Multipath	No	No
10	Fading Multipath	Yes	No
11	Fading Multipath	No	Yes
12	Fading Multipath	Yes	Yes

there is no ML estimation in this simulation, which uses the CP to find the symbol-time delay.

4.2.2 Simulation 2. The simulation from Fig. 4.2 is evaluated with no channel. The symbol-time delay is known to the jamming signal, but unknown to the demodulator. The plot shows the CP-jammer is more effective at jamming signals at all SIRs. This significant result shows that concentrating jamming signals into the CP can be a better jamming technique. To test the performance of the ML estimator at the receiver, the RMSE of the ML estimator is calculated. Fig. 4.3 shows that the ML estimator used at the receiver has a RMSE that does not exceed 4 samples in any case. The CP-jamming case at an SIR = 0 dB is the only case that consistently has errors at all SNRs ranging between an RMSE of 1-3.5 samples. The All-jamming case at an SIR = 0 dB spikes at SNR = 2 and 10 dB. The spikes are due to the fact that errors do not occur often so when there is an error, it is a high enough error to show on the RMSE plot as a spike rather than at approximately zero.

4.2.3 Simulation 3. The simulation from Fig. 4.4 is evaluated with no channel. The symbol-time delay is unknown to the jamming signal, but known to the demodulator. The plot shows the All-jammer is more effective at jamming signals

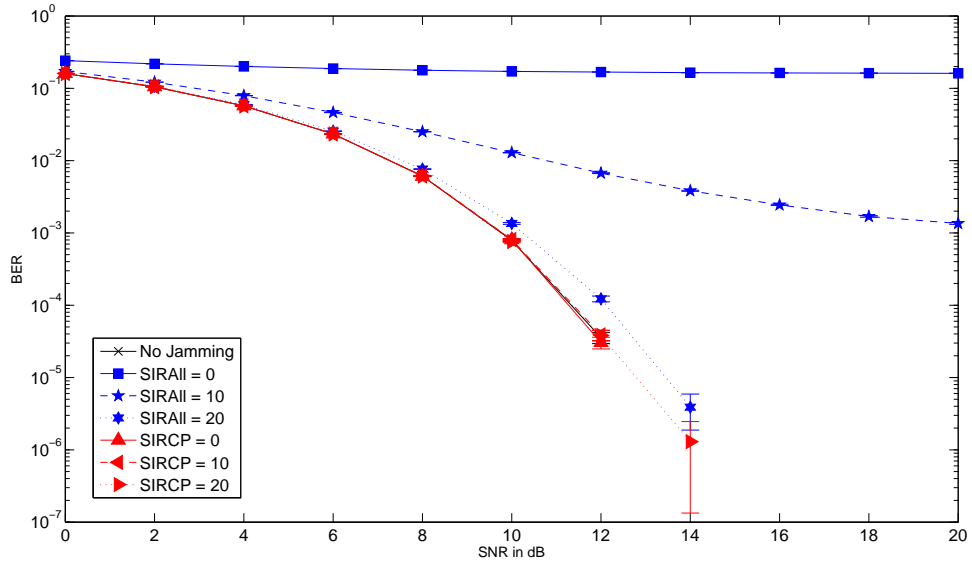

Figure 4.1: BER of OFDM signal with no channel (Simulation 1)

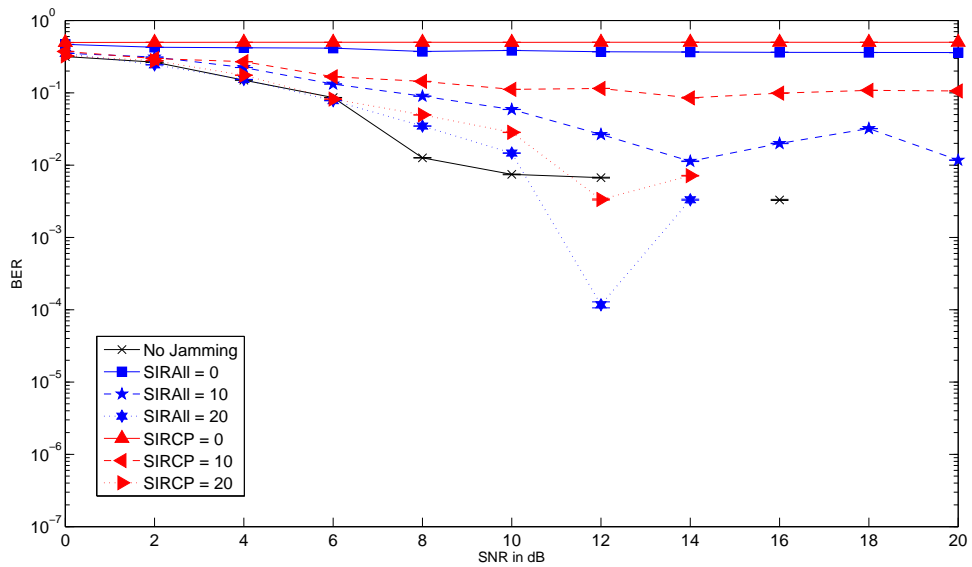

Figure 4.2: BER of OFDM signal with no channel and ML estimator at the receiver but not the jammer (Simulation 2)

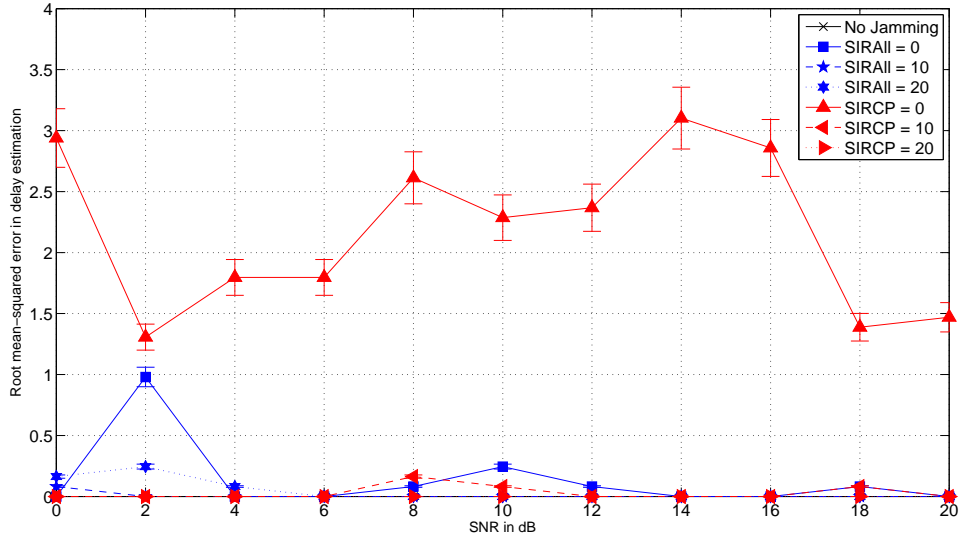

Figure 4.3: RMSE of ML estimator at the receiver with no channel (Simulation 2)

and overall, the results are very similar to simulation 1. To test the performance of the ML estimator at the jammer, the RMSE of the ML estimator is calculated. Fig. 4.5 shows that the ML estimator has a RMSE that does not exceed 1 sample in any case. The CP-jamming case at an SIR = 10 dB and SNR = 0 dB is the only case the RMSE is at nearly 1 sample. At SNR = 6 dB, there are slight errors in more cases than the other SNR values. Overall, there is very little error in the ML estimation for the jamming signal in simulation 3.

4.2.4 Simulation 4. The simulation from Fig. 4.6 is evaluated with no channel. The symbol-time delay is unknown to the jamming signal and the demodulator. The plot shows the CP-jammer is more effective at jamming signals when SIR = 0 and 10 dB. When SIR = 20 dB, both jammers are close in effectiveness to jam signals, but at SNR = 6 dB and 10 dB, the CP-jammer is better at jamming signals. To test the performance of the ML estimator at the jammer and receiver, the RMSE of the ML estimator is calculated. Fig. 4.7 shows that the ML estimator used for the jamming signal has very little to no RMSE. At SNR = 2 and 4 dB, there are slight errors in more cases than the other SNR values. Fig. 4.8 shows the RMSE of the ML

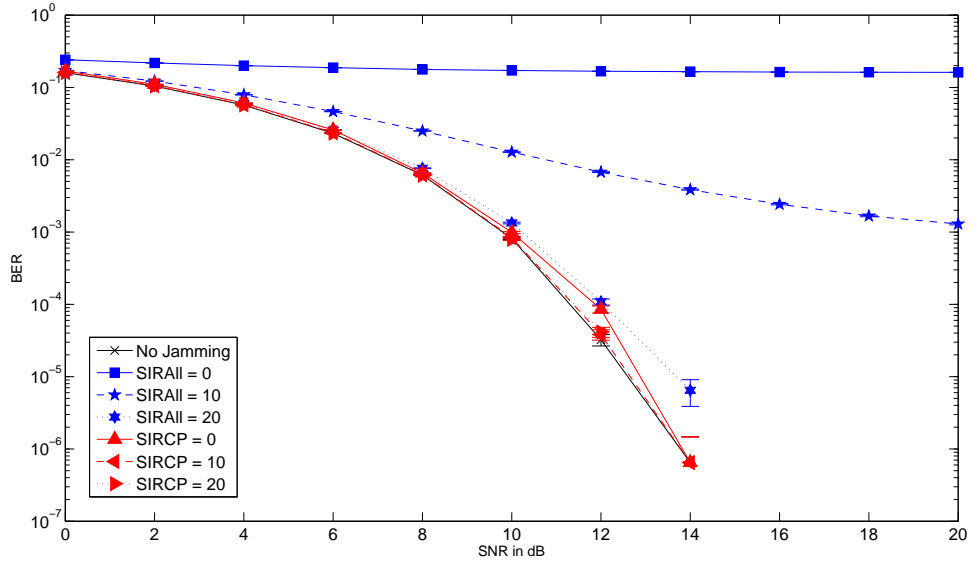

Figure 4.4: BER of OFDM signal with no channel and ML estimator at the jammer but not the receiver (Simulation 3)

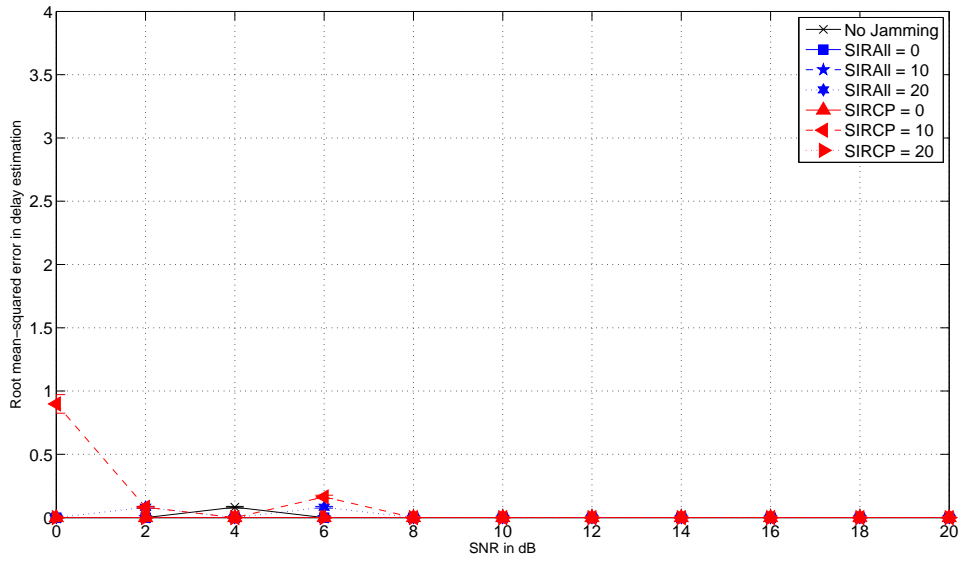

Figure 4.5: RMSE of ML estimator at the jammer with no channel (Simulation 3)

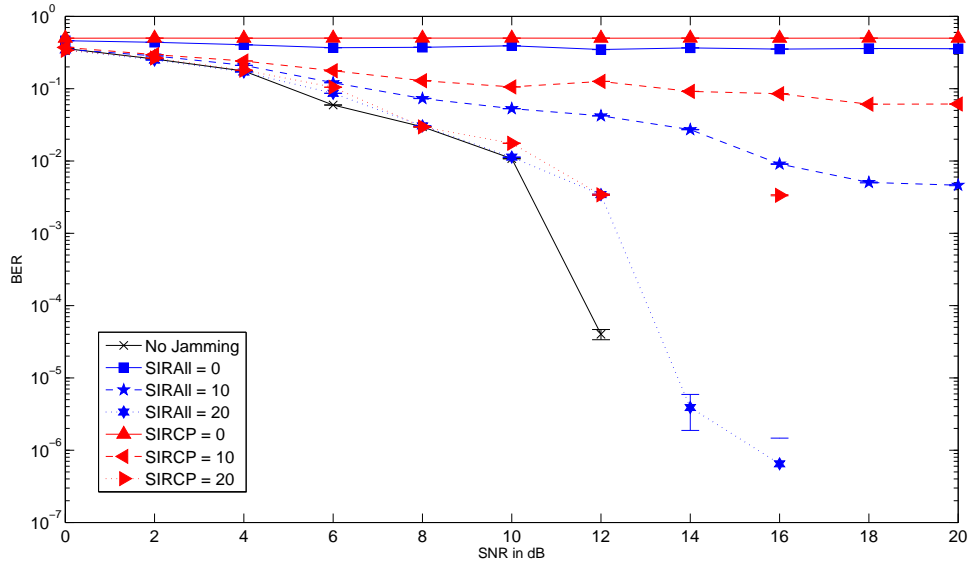

Figure 4.6: BER of OFDM signal with no channel and ML estimator at the jammer and receiver (Simulation 4)

estimator used for the receiver. The CP-jammer at SIR = 0 dB is the only case that consistently has errors at all SNRs ranging between 1-3 samples. The All-jammer at SIR = 0 dB spikes to about 1.5 samples at SNR = 2 and 10 dB. The errors shown in Fig. 4.8 reflect the rough plots in Fig. ??.

4.2.5 Simulation 5. The simulation from Fig. 4.9 is evaluated with a simple multipath channel. The symbol-time delay is known to the jamming signal and the demodulator. The plot shows the All-jammer is more effective at jamming signals at all SIRs. As with simulation 1, the symbol-time delay is a known, so no extra noise is added to the desired signal and the CP plays no part in the demodulator in this case. So the CP-jammer results are like the no jamming case.

4.2.6 Simulation 6. The simulation from Fig. 4.10 is evaluated with a simple multipath channel. The symbol-time delay is known to the jamming signal, but unknown to the demodulator. The plot shows the CP-jammer is more effective at jamming signals at SIR = 0 dB and 10 dB. So similarly to simulation 2, when the

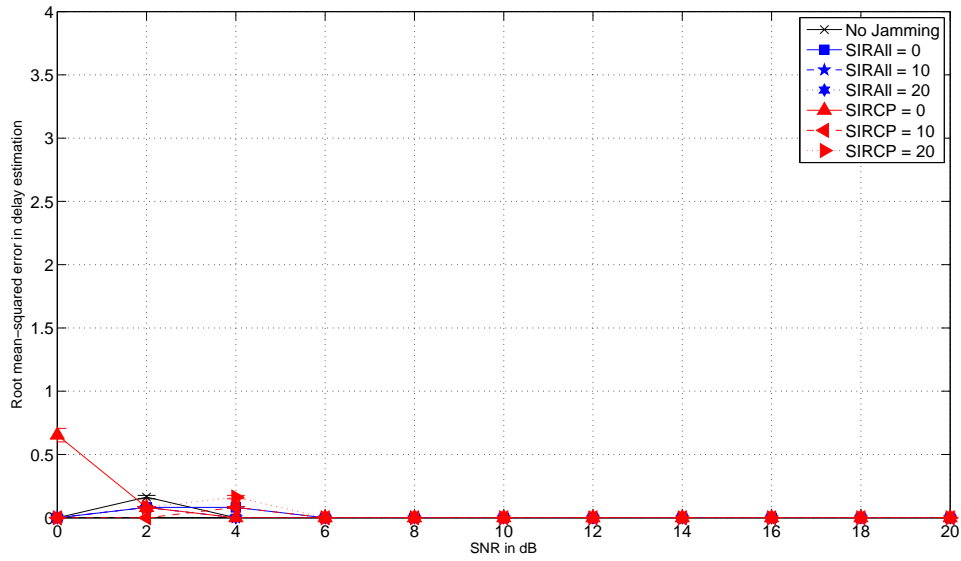

Figure 4.7: RMSE of ML estimator at the jammer with no channel (Simulation 4)

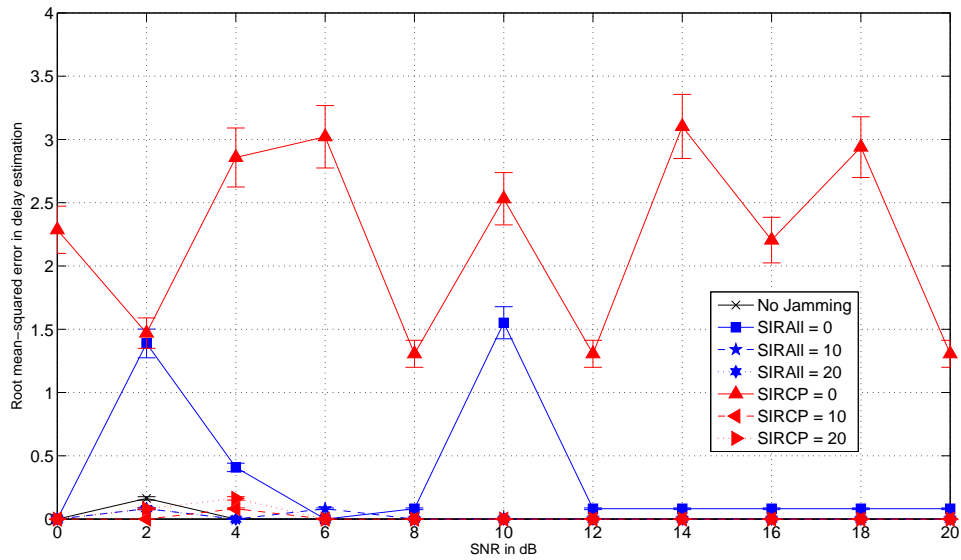

Figure 4.8: RMSE of ML estimator at the receiver with no channel (Simulation 4)

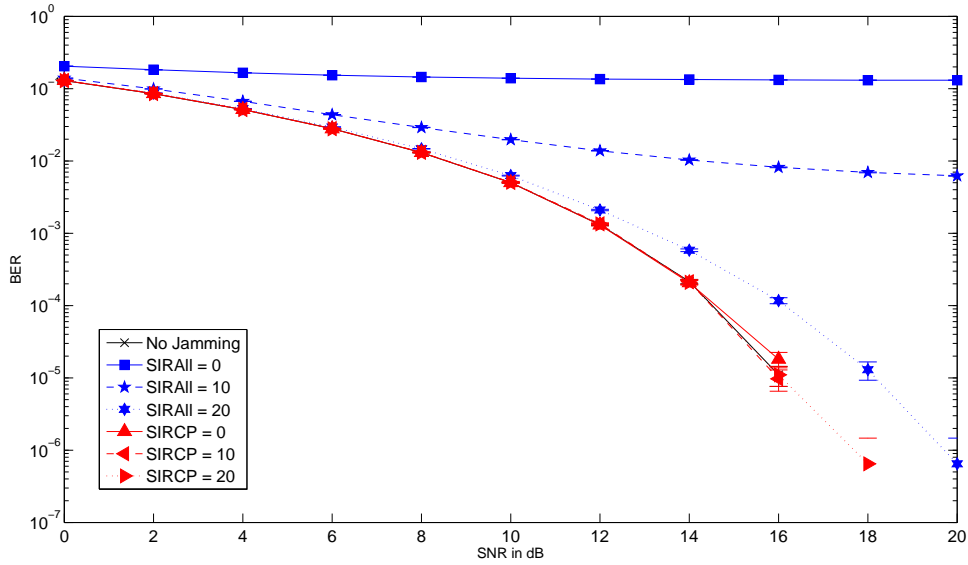

Figure 4.9: BER of OFDM signal with a simple multipath channel (Simulation 5)

receiver uses ML estimation for the symbol-time delay and not the jammer, the CP-jammer is better at jamming signals. For SIR = 20 dB, each case results in similar effectiveness to jam signals. To test the performance of the ML estimator at the receiver, the RMSE of the ML estimator is calculated. Fig. 4.11 shows that the ML estimator used at the receiver has a RMSE that does not exceed 1 sample in most cases. The CP-jamming case at SIR = 0 dB is the only case that consistently has errors at all SNRs ranging between 1-3.5 samples.

4.2.7 Simulation 7. The simulation from Fig. 4.12 is evaluated with a simple multipath channel. The symbol-time delay is unknown to the jamming signal, but known to the demodulator. The plot shows the All-jammer is more effective at jamming signals comparing the SIR. When SNR = 14-20 dB, the CP-jammer at SIR = 0 dB is more effective at jamming signals than the All-jammer at SIR = 20 dB. This jump in BER is due to the CP-jamming signal not lining up exactly so with the desired signal, which results in a more concentrated noise signal around the CP for the receiver. To test the performance of the ML estimator at the jammer, the RMSE

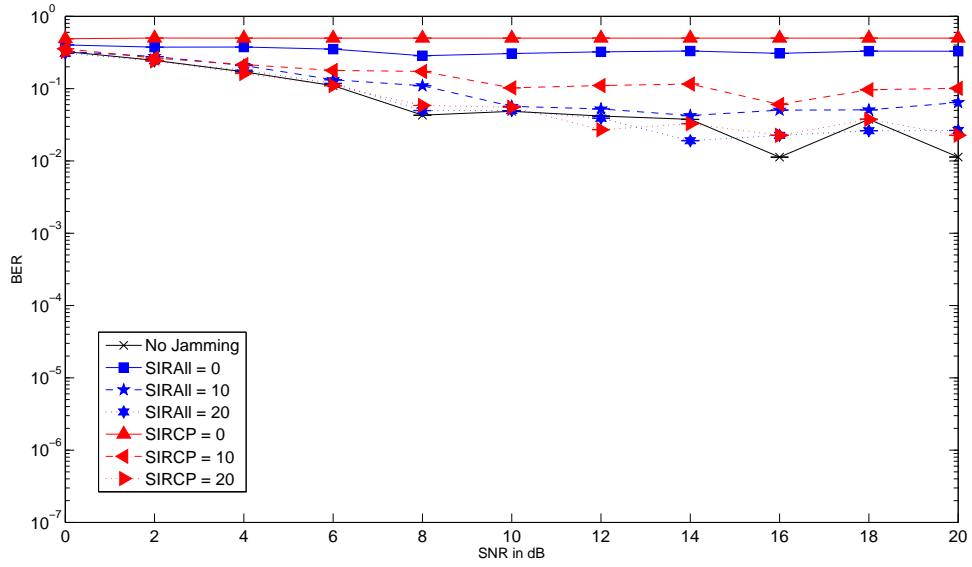

Figure 4.10: BER of OFDM signal with a simple multipath channel and ML estimator at the receiver but not the jammer (Simulation 6)

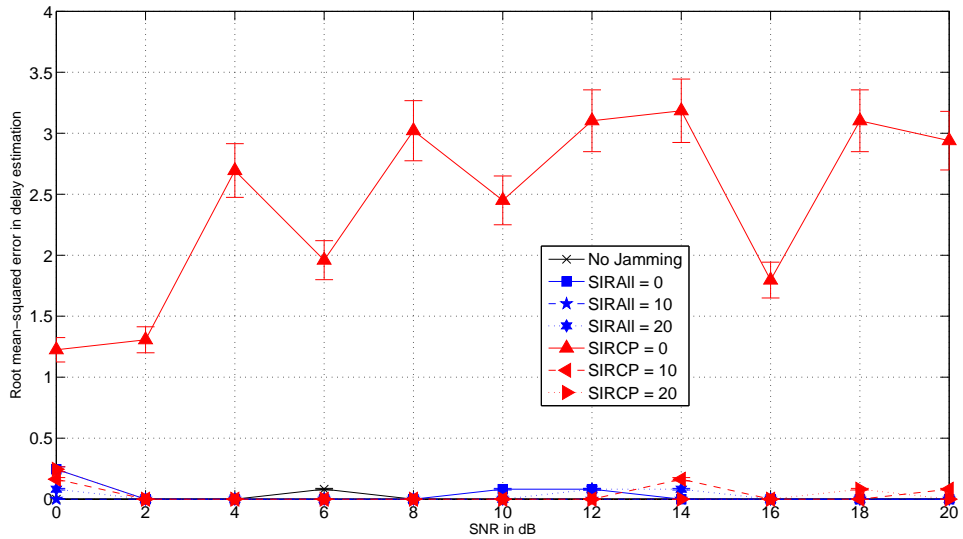

Figure 4.11: RMSE of ML estimator at the receiver with a simple multipath channel (Simulation 6)

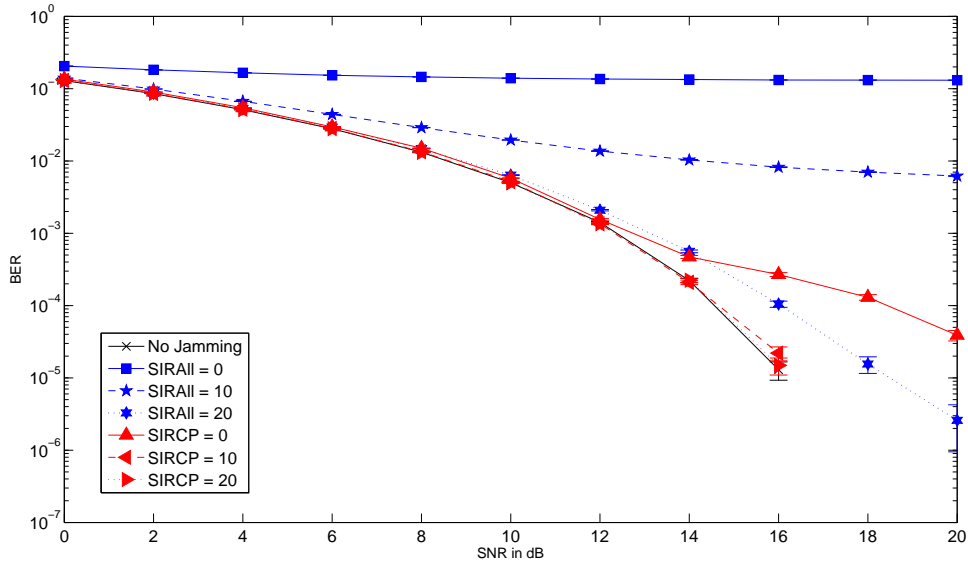

Figure 4.12: BER of OFDM signal with a simple multipath channel and ML estimator at the jammer but not the receiver (Simulation 7)

of the ML estimator is calculated. Fig. 4.13 shows that the ML estimator used at the jammer has a RMSE that does not exceed 1 sample in any case. Overall, there is very little error in the ML estimation for the jamming signal in simulation 7.

4.2.8 Simulation 8. The simulation from Fig. 4.14 is evaluated with a simple multipath channel. The symbol-time delay is unknown to the jamming signal and demodulator. The plot shows the CP-jammer is more effective at jamming signals at SIR = 0 dB and 10 dB. So similarly to simulation 6, when the receiver uses ML estimation for the symbol-time delay, the CP-jammer is better at jamming signals. For SIR = 20 dB, there is no definitive case that outperforms the other. To test the performance of the ML estimator at the receiver, the RMSE of the ML estimator is calculated. Fig. 4.15 shows that the ML estimator used for the jamming signal has a RMSE that does not exceed 1 sample in any case. Fig. 4.16 shows the RMSE of the ML estimator used for the receiver. The CP-jammer at SIR = 0 dB is the only case that consistently has errors at all SNRs ranging between 1.5-3.5 samples.

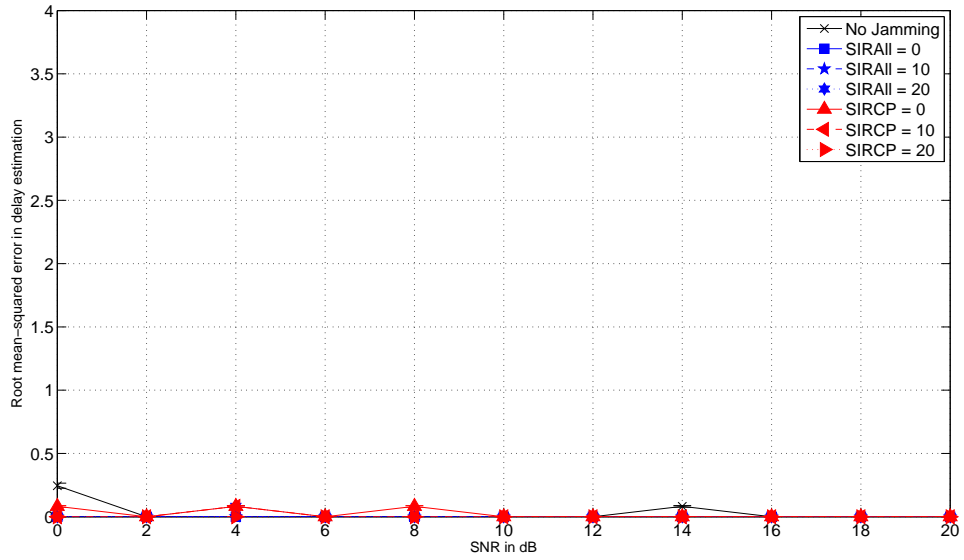

Figure 4.13: RMSE of ML estimator at the jammer with a simple multipath channel (Simulation 7)

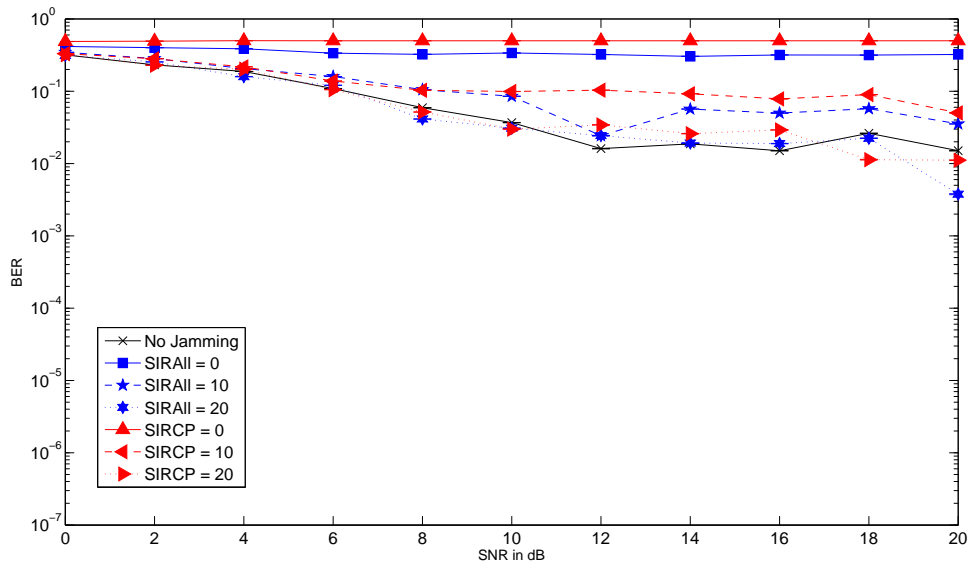

Figure 4.14: BER of OFDM signal with a simple multipath channel and ML estimator at the jammer and receiver (Simulation 8)

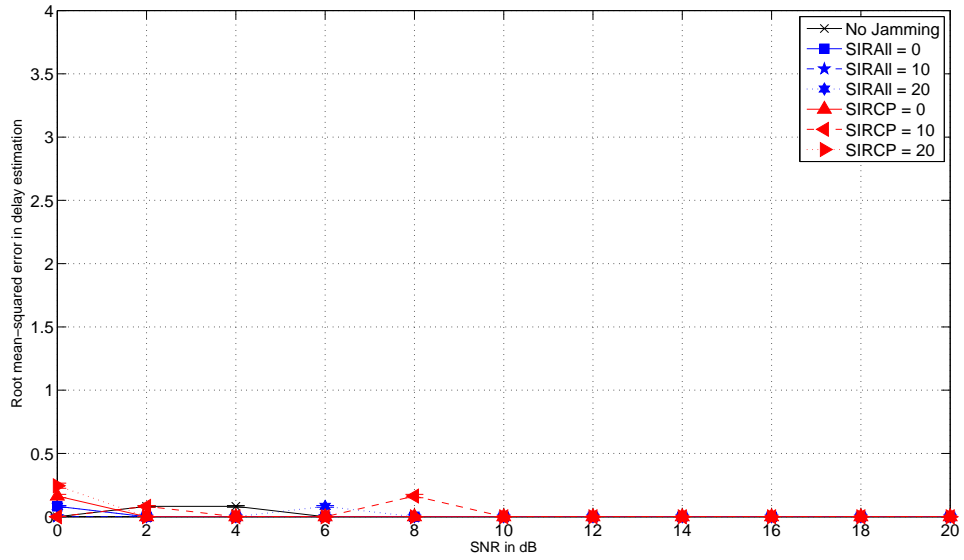

Figure 4.15: RMSE of ML estimator at the jammer with a simple multipath channel (Simulation 8)

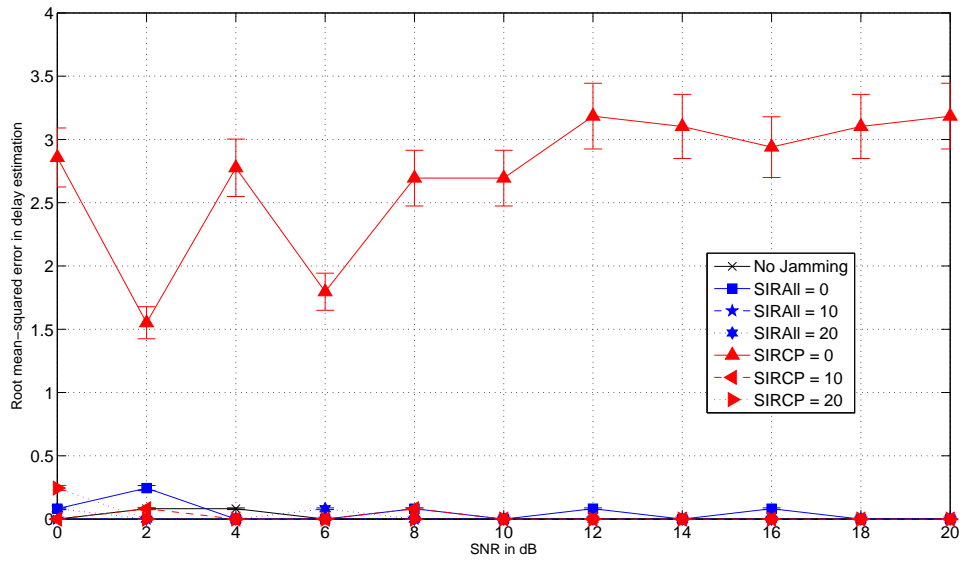

Figure 4.16: RMSE of ML estimator at the receiver with a simple multipath channel (Simulation 8)

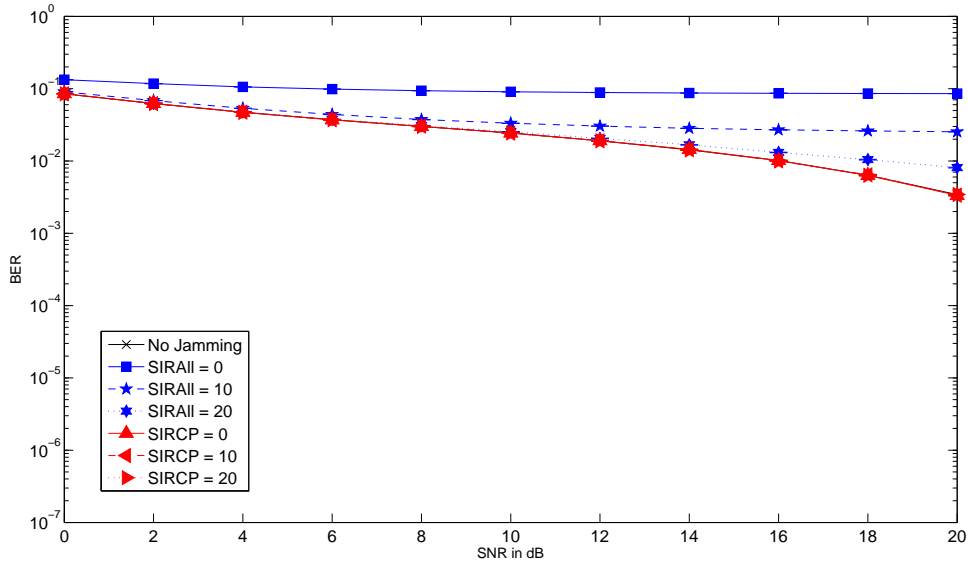

Figure 4.17: BER of OFDM signal with a fading multipath channel (Simulation 9)

4.2.9 *Simulation 9.* The simulation from Fig. 4.17 is evaluated with a fading multipath channel. The symbol-time delay is known to the jamming signal and the demodulator. The plot shows the All-jammer is more effective at jamming signals at all SIRs. As with simulations 1 and 5, the symbol-time delay is a known, so no extra noise is added to the desired signal and the CP plays no part in the demodulator in this case. So the CP-jammer results are like the no jamming case.

4.2.10 *Simulation 10.* The simulation from Fig. 4.18 is evaluated with a fading multipath channel. The symbol-time delay is known to the jamming signal, but unknown to the demodulator. Note that the plot is shown with a smaller BER range. The plot does not give any definitive information. In Sec. 4.3, the results are looked at closer in comparison to the other simulations. To test the performance of the ML estimator at the receiver, the RMSE of the ML estimator is calculated. Fig. 4.19 shows that the ML estimator used at the receiver has a RMSE that does not exceed 1 sample in most cases. There is one spike in the results. The CP-jammer at SIR = 0 dB and SNR = 20 dB spikes to about a RMSE of 2.25 samples.

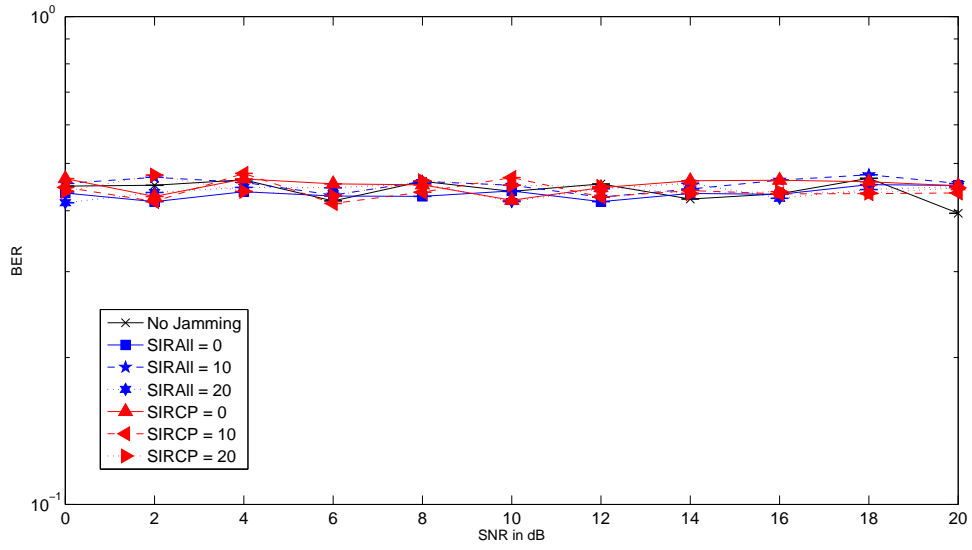

Figure 4.18: BER of OFDM signal with a fading multipath channel and ML estimator at the receiver but not the jammer (Simulation 10)

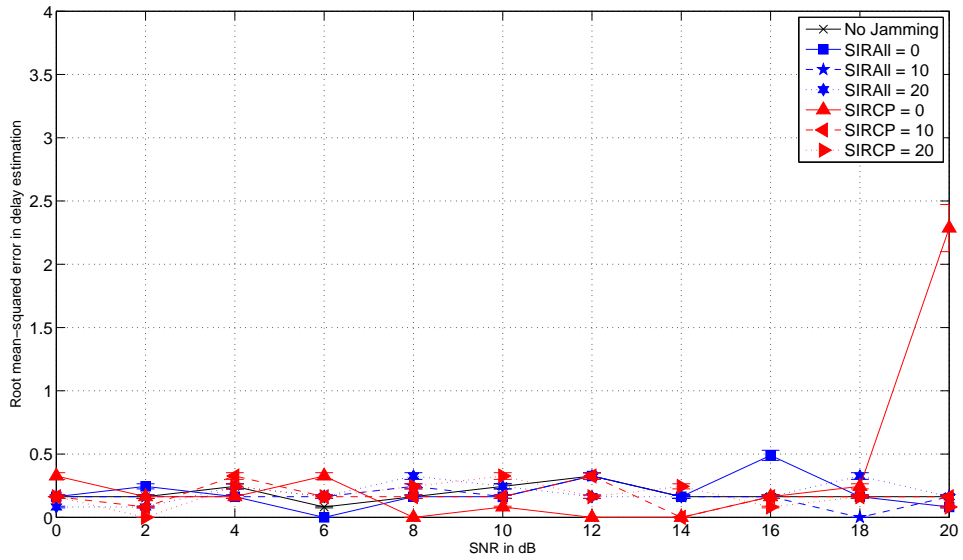

Figure 4.19: RMSE of ML estimator at the receiver with a fading multipath channel (Simulation 10)

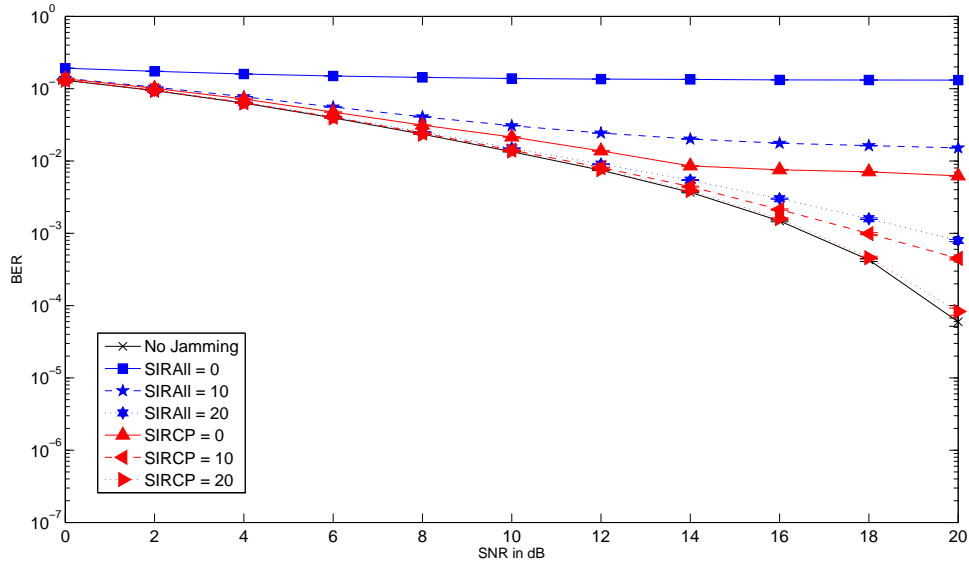

Figure 4.20: BER of OFDM signal with a fading multipath channel and ML estimator at the jammer but not the receiver (Simulation 11)

4.2.11 Simulation 11. The simulation from Fig. 4.20 is evaluated with a fading multipath channel. The symbol-time delay is unknown to the jamming signal, but known to the demodulator. The plot shows the All-jammer is more effective at jamming signals comparing the SIR. To test the performance of the ML estimator at the jammer, the RMSE of the ML estimator is calculated. Fig. 4.21 shows that the ML estimator used at the jammer has a RMSE that does not exceed 1 sample in any case. Overall, there is very little error in the ML estimation for the jamming signal in simulation 11.

4.2.12 Simulation 12. The simulation from Fig. 4.22 is evaluated with a fading multipath channel. The symbol-time delay is unknown to the jamming signal and demodulator. Note that the plot is shown with a smaller BER range. The plot only clearly shows that the CP-jammer is more effective at jamming signals at SIR = 0 dB. Otherwise the results are used in Sec. 4.3 to take a closer look. To test the performance of the ML estimator at the jammer and receiver, the RMSE of the ML estimator is calculated. Fig. 4.23 shows that the ML estimator used at the jammer

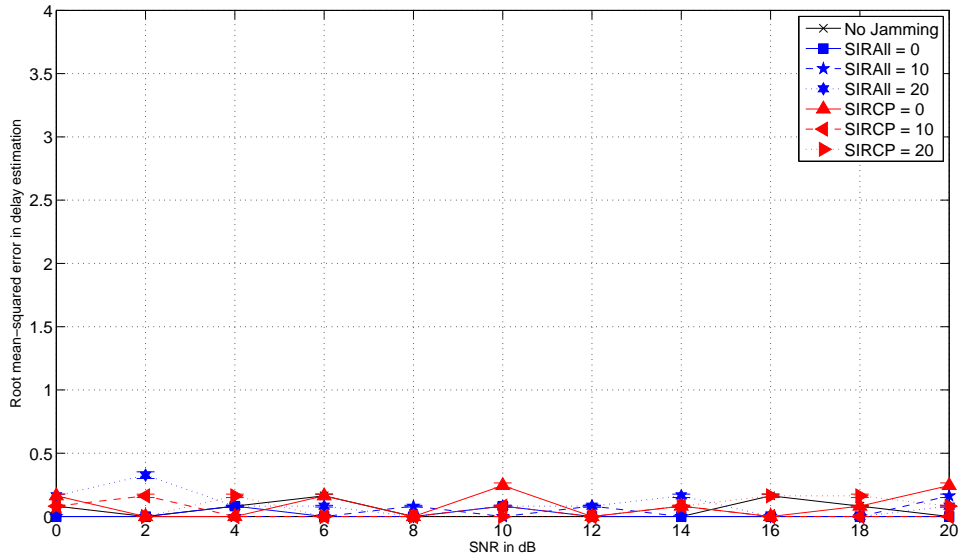

Figure 4.21: RMSE of ML estimator at the jammer with a fading multipath channel (Simulation 11)

has a RMSE that does not exceed 1 sample in any case. Fig. 4.24 shows that the ML estimator used at the receiver has a RMSE that does not exceed 1 sample in most cases. The CP-jamming case at SIR = 0 dB is the only case that has errors ranging between 0-3 samples.

4.3 Comparison

In order to compare all 12 simulations, BER values for a given SNR and SIR are plotted against each other. Fig. 4.25 shows a bar plot that compares the BER of each simulation of each case with SNR = 10 dB and SIR = 10 dB. Each bar also has an error bar highlighted in purple and provides the information to show that none of the BER values provided in the comparison chart are statistically equal. The better jammer is also highlighted in the figure as a “C” or an “A” to label in each simulation the better jammer as the CP-jammer or the All-jammer respectively. This plot has a general trend that shows whenever the receiver uses the ML estimator to find the symbol-time delay, the CP-jammer is a more effective jammer. As the channel becomes more complex, the CP-jammer had less of an advantage over the

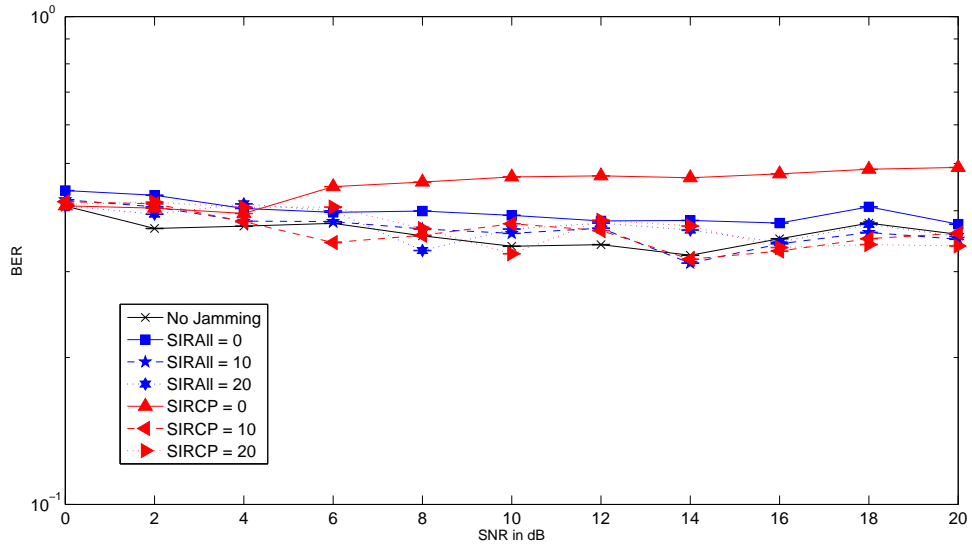

Figure 4.22: BER of OFDM signal with a fading multipath channel and ML estimator at the jammer and receiver (Simulation 12)

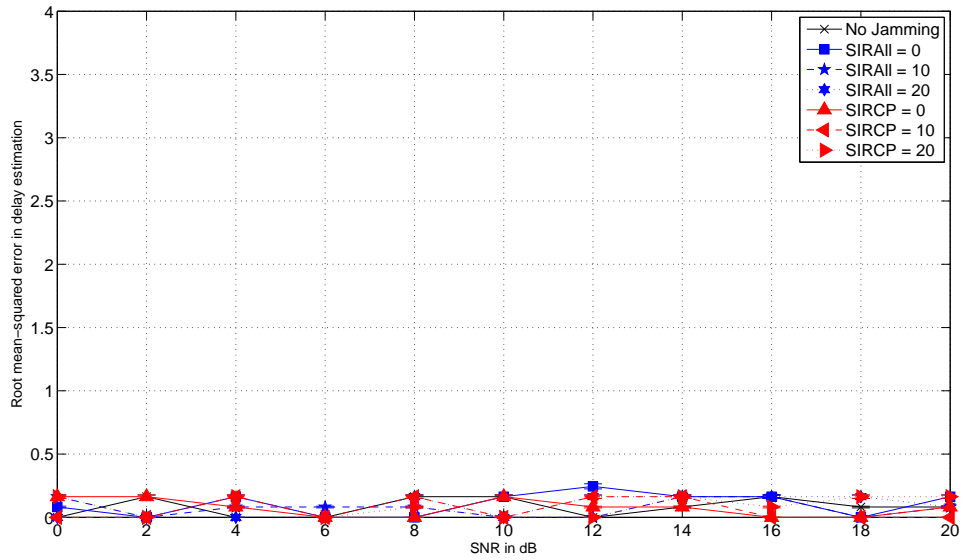

Figure 4.23: RMSE of ML estimator at the jammer with a fading multipath channel (Simulation 12)

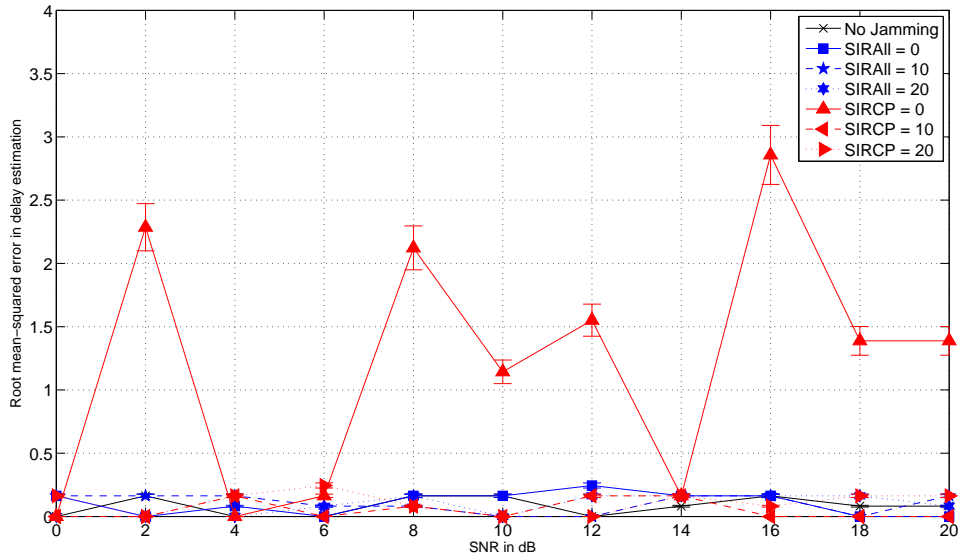

Figure 4.24: RMSE of ML estimator at the receiver with a fading multipath channel (Simulation 12)

All-jammer. This is the general trend at most SNR and SIR values. Tab. 4.1 provides the reference for the simulation numbers.

Fig. 4.26 shows a bar plot that compares the BER of each simulation of each case with SNR = 10 dB and SIR = 20 dB. For simulations 1-7, the general trend shown in Fig 4.25 applies. In simulation 8, the All-jammer is a more effective jammer still, but not by a significant difference in the BER value. Simulations 9-12 have the same trend as shown in simulations 5-8. As a general observation, the plots show that as the channel conditions become more complex, the difference in the effectiveness of each jammer becomes less.

Fig. 4.27 shows a scatter plot of RMSE of the ML estimator for the receiver versus BER with SNR = 10 dB. The points are plotted at SIR = 0 dB (empty circles) and SIR = 10 dB (filled circles). These SIR values were chosen because at 20 dB, there are few values that are not at an RMSE of zero samples. The trend shows that as the BER value increases, the value of the RMSE increases. This trend makes sense because the jammers are expected to cause the ML estimator at the receiver to have

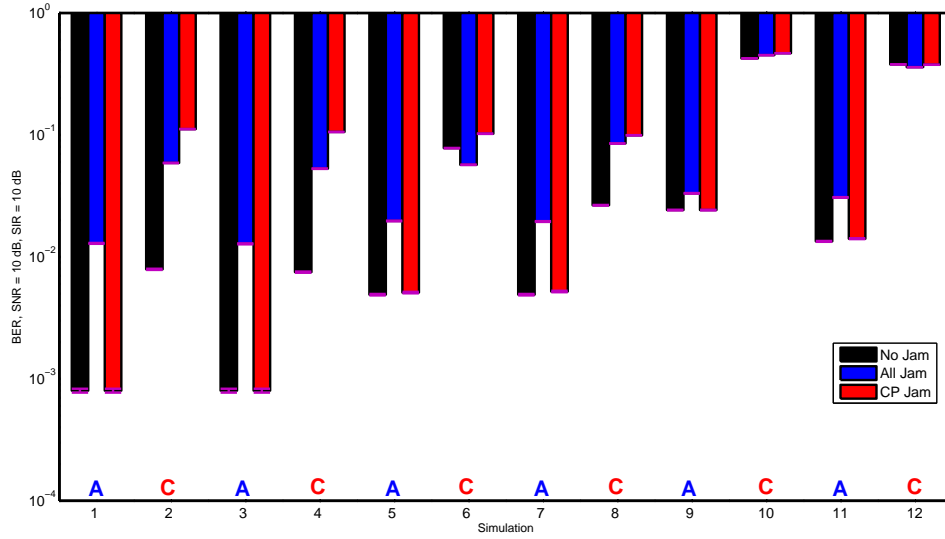

Figure 4.25: BER Bar Plot: SNR = 10dB, SIR = 10dB

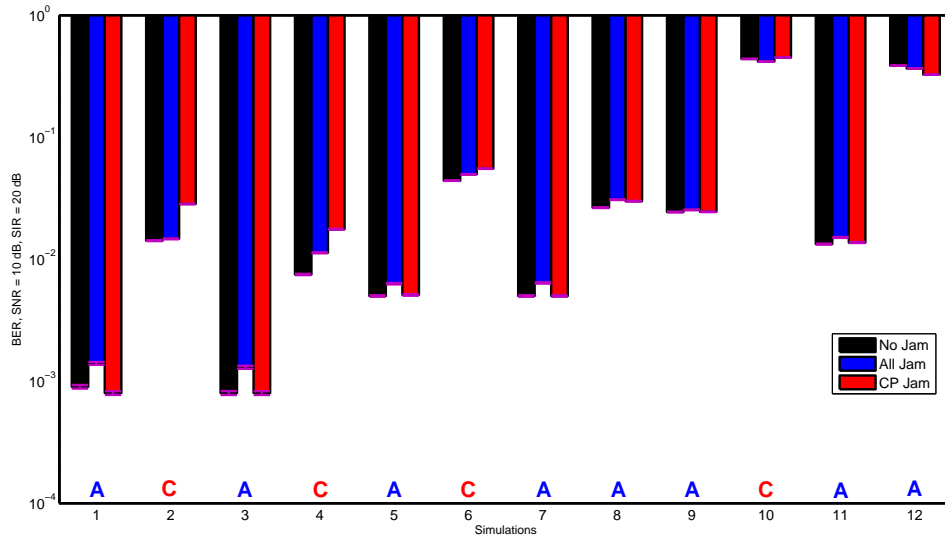

Figure 4.26: BER Bar Plot: SNR = 10dB, SIR = 20dB

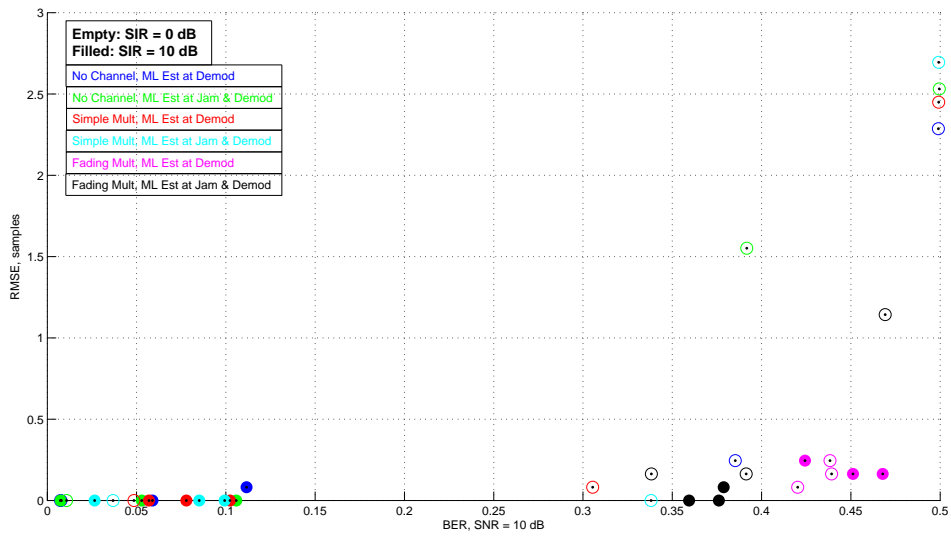

Figure 4.27: RMSE of ML Estimator for the Receiver vs BER, SNR = 10 dB

more error in its estimation of the symbol-time delay; the more error that is in this estimation, the more bit errors that are expected. The plot also shows that the RMSE is higher when SIR = 0 dB.

V. Conclusions

This chapter contains concluding comments about the research in this thesis and recommendations for future work.

5.1 Conclusion

The All-jammer and the CP-jammer are compared in no channel, a simple multipath channel, and a fading multipath channel using ML estimation for the symbol-time delay at the jammer, receiver, both, or neither using BER plots. The general trend is if the receiver uses the ML estimator for the symbol-time delay, the CP-jammer is a more effective jammer. This is because the power of the jamming signal in only the CP affects the use of the ML estimator, which uses the CP to estimate the symbol-time delay. Instead of the evenly spread power of the All-jammer across the entire signal, the CP-jammer concentrates its interfering signal power to just the CP to throw off the ML estimator in an efficient way.

The general trend is not always the case if the ML estimator is used at both the jammer and receiver and the SIR value increases. The difference in the BER values of the two cases also lessen as the channel conditions become more complex. When the ML estimator is used at the receiver, the difference in the BER values in the fading multipath channel and sometimes the simple multipath channel are very small.

5.2 Future Work

5.2.1 Maximum Likelihood Estimator. In this research, the jammer and the receiver both use a ML estimator to find the symbol-time delay of the transmitted signal. The ML estimator uses the CP of an OFDM signal to calculate this delay since the CP and its copy are pairwise correlated [14]. The jammer uses the estimator in order to match up the jamming signal to the transmitted signal. The receiver uses the estimator in order to demodulate the signal with fewer errors in the received signal.

In [14], the authors have a ML estimator based not only on the symbol-time delay, but also the frequency offset of the transmitted signal, which creates a more

complex/realistic problem. Creating a simulation which includes a frequency offset in the signal and ML estimator as well as the symbol-time delay from this thesis would be an interesting issue to research.

5.2.2 Jamming Techniques. In this research, there are only two jamming techniques that are compared. The first is an AWGN jammer which sends an interfering signal along with the desired signal with the intent of either overwhelming the power of the desired signal or preventing the receiver from properly extracting the desired information. This technique is a great basis for comparing other jamming techniques because it is the most basic and common technique for jamming signals. The second technique used is an AWGN jammer that only jams the CP of the OFDM signal. This is done in hopes of preventing the ML estimator for the symbol-time delay to function properly at the receiver. There are many more jamming techniques that can be tested and compared to find the most efficient way to jam an OFDM signal. Another interesting case would be to find ways to jam a multiple access signal such as OFDMA. Trying to jam only the frequency used by the desired signal while leaving all other signals unscathed for a multiple access signal is an example of finding another way to jam a signal.

5.2.3 Signal Types. This research uses an OFDM signal to test jamming techniques. While OFDM is a great basis for jamming communication signals, other signals that are commonly used can be tested in a similar way. Some signal types that are related to this research include:

- OFDMA: this multiple access version of an OFDM signal also uses a CP
- SC-FDMA: this single channel signal uses a CP
- LTE: this system uses OFDMA in the downlink and SC-FDMA in the uplink [9]

Bibliography

1. R. Prasad, *OFDM for Wireless Communications Systems*. Boston: British Library Cataloguing in Publication Data, 2004.
2. A. Doufexi, S. Armour, A. Nix, and M. Beach, "Design considerations and initial physical layer performance results for a space time coded OFDM 4G cellular network," *13th IEEE Int. Symp.*, vol. 1, p. 192, Sep 2002.
3. Telecommunication training VoIP, IP and MPLS training blog, "4G Cellular OFDM and LTE-the "GSM vs. CDMA" Standards War Ends!," 2008. [Online]. Available: <http://blog.teracomtraining.com/4g-cellular-ofdm-and-lte-the-gsm-vs-cdma-standards-war-ends>.
4. Verizon Wireless. [Online]. Available: <http://blog.teracomtraining.com/4g-cellular-ofdm-and-lte-the-gsm-vs-cdma-standards-war-ends>.
5. Department of the Air Force, Air Force Materiel Command, AFRL-Rome Research Site, "Dominant Cyber Offensive Engagement and Supporting Technology." [Online]. Available: https://www.fbo.gov/index?s=opportunity&mode=form&id=b34f1f48d3ed2ce781f85d28f700a870&tab=core&_cview=0.
6. D. Adamy, *EW 101 A First Course in Electronic Warfare*. Boston: Artech House, Inc., 2001.
7. A. Chevalier, "How Do GPS Signal Jammers Work?," Dec 2009. [Online]. Available: <http://www.brighthub.com/electronics/gps/articles/60598.aspx>.
8. LTE Product Design, "LTE Benefits v 3.3," May 2009. [Online]. Available: <https://www.lte.vzw.com/Portals/95/docs/LTE%20Benefits%20Guide.pdf>.
9. Adrio Communications, "LTE OFDM, OFDMA and SC-FDMA." [Online]. Available: <http://www.radio-electronics.com/info/cellulartelecomms/lte-long-term-evolution/lte-ofdm-ofdma-scfdma.php>.
10. D. Kivanc, G. Li, and Hui Liu, "Computationally Efficient Bandwidth Allocation and Power Control for OFDMA," *IEEE Trans. on Wireless Comm.*, vol. 2, pp. 1150–1158, Nov 2003.
11. K. Eriksson, "Channel Tracking versus Frequency Hopping for Uplink LTE," Mar 2007. [Online]. Available: <http://www.ee.kth.se/php/modules/publications/reports/2007/IR-SB-.pdf>.
12. J. Moon, J. Shea, and T. Wong, "Pilot-Assisted and Blind Joint Data Detection and Channel Estimation in Partial-Time Jamming," *IEEE Trans. on Comm.*, pp. 2092–2102, Nov 2006.

13. J. Moon, J. Shea, and T. Wong, "Collaborative Mitigation of Partial-Time Jamming on Nonfading Channels," *IEEE Trans. on Wireless Comm.*, Jun 2006.
14. J. J. van de Beek, M. Sandell, and P. O. Börjesson, "ML Estimation of Time and Frequency Offset in OFDM Systems," *IEEE Trans. Signal Proc.*, vol. 45, pp. 1800–1805, Jul 1997.
15. A. Oppenheim, R. Schafer, and J. Buck, *Discrete-Time Signal Processing*. Upper Saddle River, NJ: Prentice-Hall, Inc., 1999.
16. K. Vanbleu, G. Ysebaert, G. Cuyppers, and M. Moonen, "On Time-Domain and Frequency-Domain MMSE-Based TEQ Design for DMT Transmission," Aug 2005.
17. R. K. Martin, "Fast-converging Blind Adaptive Channel Shortening and Frequency-domain Equalization," *IEEE Trans. Signal Proc.*, vol. 55, pp. 102–110, Jan 2007.
18. R. K. Martin, "Matlab code for Rick Martin's publications."
19. A. Leon-Garcia, *Probability, Statistics, and Random Processes for Electrical Engineering*. Upper Saddle River, NJ: Pearson Prentice Hall, 2008.

REPORT DOCUMENTATION PAGE

Form Approved
OMB No. 0704-0188

The public reporting burden for this collection of information is estimated to average 1 hour per response, including the time for reviewing instructions, searching existing data sources, gathering and maintaining the data needed, and completing and reviewing the collection of information. Send comments regarding this burden estimate or any other aspect of this collection of information, including suggestions for reducing this burden to Department of Defense, Washington Headquarters Services, Directorate for Information Operations and Reports (0704-0188), 1215 Jefferson Davis Highway, Suite 1204, Arlington, VA 22202-4302. Respondents should be aware that notwithstanding any other provision of law, no person shall be subject to any penalty for failing to comply with a collection of information if it does not display a currently valid OMB control number. PLEASE DO NOT RETURN YOUR FORM TO THE ABOVE ADDRESS.

1. REPORT DATE (DD-MM-YYYY) 24-03-2011		2. REPORT TYPE Master's Thesis		3. DATES COVERED (From — To) August 2009-March 2011	
4. TITLE AND SUBTITLE Effects of Cyclic Prefix Jamming Versus Noise Jamming in OFDM Signals				5a. CONTRACT NUMBER NA	
				5b. GRANT NUMBER NA	
				5c. PROGRAM ELEMENT NUMBER NA	
6. AUTHOR(S) Scott, Amber L., 2d Lt, USAF				5d. PROJECT NUMBER NA	
				5e. TASK NUMBER NA	
				5f. WORK UNIT NUMBER NA	
7. PERFORMING ORGANIZATION NAME(S) AND ADDRESS(ES) Air Force Institute of Technology Graduate School of Engineering and Management (AFIT/EN) 2950 Hobson Way WPAFB OH 45433-7765 DSN: 785-3636				8. PERFORMING ORGANIZATION REPORT NUMBER AFIT/GE/ENG/11-35	
9. SPONSORING / MONITORING AGENCY NAME(S) AND ADDRESS(ES) Air Force Research Laboratory, AFMC Attn: AFRL/Ryre (Dr. Vasu Chakravarthy) 2241 Avionics Circle, Bldg 620 WPAFB OH 45433-7734 (937)798-8269 Vasu.Chakravarthy@wpafb.af.mil				10. SPONSOR/MONITOR'S ACRONYM(S) AFRL/Ryre	
				11. SPONSOR/MONITOR'S REPORT NUMBER(S)	
12. DISTRIBUTION / AVAILABILITY STATEMENT APPROVED FOR PUBLIC RELEASE; DISTRIBUTION UNLIMITED; THIS MATERIAL IS DECLARED A WORK OF THE U.S. GOVERNMENT AND IS NOT SUBJECT TO COPYRIGHT PROTECTION IN THE UNITED STATES					
13. SUPPLEMENTARY NOTES					
14. ABSTRACT Signal jamming of an orthogonal frequency-division multiplexing (OFDM) signal is simulated in MATLAB. Two different means of jamming are used to see, which is a more efficient way to disrupt a signal using the same signal power. The first way is a basic additive white Gaussian noise (AWGN) jammer that equally jams the entire signal. The second way is an AWGN jammer that targets only the cyclic prefix (CP) of the signal. These two methods of jamming are simulated using different channel models and unknowns to get varying results. The three channel models used in the simulations are the no channel case, the simple multipath case, and the fading multipath case. The general trend shows that as the channel model becomes more complex, the difference in the effectiveness of each jamming technique becomes less. The unknown in this research is the symbol-time delay. Since OFDM signals are characterized by multipath reception, the signal arrives at a symbol-time delay which is known or unknown to the jamming signal and the receiver. Realistically, the symbol-time delay is unknown to each and in that case, a Maximum Likelihood (ML) Estimator is used to find the estimated symbol-time delay. This research simulates the symbol-time delay as a known and an unknown at the jammer and receiver. The general trend shows that jamming the cyclic prefix is more effective than noise jamming when the symbol-time delay is unknown to the receiver.					
15. SUBJECT TERMS OFDM, Signal Jamming, CP					
16. SECURITY CLASSIFICATION OF:			17. LIMITATION OF ABSTRACT	18. NUMBER OF PAGES	19a. NAME OF RESPONSIBLE PERSON
a. REPORT	b. ABSTRACT	c. THIS PAGE			Dr. Richard K. Martin (ENG)
U	U	U	UU	59	19b. TELEPHONE NUMBER (include area code) (937)255-3636x4625; email:richard.martin@afit.edu