



**AFRL-RH-BR-TR-2011-0007**

**Five-Axis Goniometric Stage**

Gary D. Noojin  
Corey A. Harbert  
Daniel P. Chacko  
David J. Stolarski



**TASC, Inc.**  
**4241 Woodcock Drive, Ste. B-100**  
**San Antonio, TX 78228**

Jeffrey W. Oliver  
**Human Effectiveness Directorate**  
**Directed Energy Bioeffects Division**  
**Optical Radiation Branch**

**February 2011**  
**Report for November 2009 to December 2010 (dates**  
**worked on)**

Pending Distribution A: Approved for  
public release; distribution unlimited  
(approval given by local Public Affairs  
Office PA# 11-112)

**Air Force Research Laboratory**  
**711 Human Performance Wing**  
**Human Effectiveness Directorate**  
**Directed Energy Bioeffects**  
**Optical Radiation Branch**  
**Brooks City-Base, TX 78235**

## NOTICE AND SIGNATURE PAGE

Using Government drawings, specifications, or other data included in this document for any purpose other than Government procurement does not in any way obligate the U.S. government. The fact that the Government formulated or supplied the drawings, specifications, or other data does not license the holder or any other person or corporation; or convey any rights or permission to manufacture, use, or sell any patented invention that may relate to them.

This report was cleared for public release by the 311<sup>th</sup> Public Affairs Office at Brooks City Base, TX and is available to the general public, including foreign nationals. Copies may be obtained from the Defense Technical Information Center (DTIC) (<http://www.dtic.mil>).

AFRL-RH-BR-TR-2011-0007 HAS BEEN REVIEWED AND IS APPROVED FOR PUBLICATION IN ACCORDANCE WITH ASSIGNED DISTRIBUTION STATEMENT.

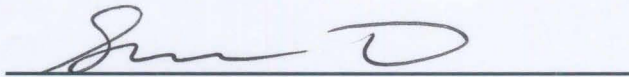

Samuel Y. O, Lt, USAF  
Work Unit Manager  
711 HPW/ RHDO



GARRETT D. POLHAMUS, Ph.D.  
Chief, Directed Energy Bioeffects Division  
Human Effectiveness Directorate  
711 Human Performance Wing  
Air Force Research Laboratory

This report is published in the interest of scientific and technical information exchange, and its publication does not constitute the Government's approval or disapproval of its ideas or findings.

# REPORT DOCUMENTATION PAGE

*Form Approved*  
*OMB No. 0704-0188*

Public reporting burden for this collection of information is estimated to average 1 hour per response, including the time for reviewing instructions, searching existing data sources, gathering and maintaining the data needed, and completing and reviewing this collection of information. Send comments regarding this burden estimate or any other aspect of this collection of information, including suggestions for reducing this burden to Department of Defense, Washington Headquarters Services, Directorate for Information Operations and Reports (0704-0188), 1215 Jefferson Davis Highway, Suite 1204, Arlington, VA 22202-4302. Respondents should be aware that notwithstanding any other provision of law, no person shall be subject to any penalty for failing to comply with a collection of information if it does not display a currently valid OMB control number. **PLEASE DO NOT RETURN YOUR FORM TO THE ABOVE ADDRESS.**

<b>1. REPORT DATE (DD-MM-YYYY)</b> 14-02-2011			<b>2. REPORT TYPE</b> Interim Technical Report		<b>3. DATES COVERED (From - To)</b>	
<b>4. TITLE AND SUBTITLE</b>  Five-Axis Goniometric Stage					<b>5a. CONTRACT NUMBER</b> FA8650-08-D-6930	
					<b>5b. GRANT NUMBER</b>	
					<b>5c. PROGRAM ELEMENT NUMBER</b> 0602202F	
<b>6. AUTHOR(S)</b> Gary D. Noojin, Corey A. Harbert, Daniel P. Chacko, David J. Stolarski, and Jeffrey Oliver					<b>5d. PROJECT NUMBER</b> 7757	
					<b>5e. TASK NUMBER</b> B2	
					<b>5f. WORK UNIT NUMBER</b> 39	
<b>7. PERFORMING ORGANIZATION NAME(S) AND ADDRESS(ES)</b> Air Force Research Laboratory 711 Human Performance Wing Human Effectiveness Directorate Directed Energy Bioeffects Optical Radiation Branch Brooks City-Base, TX 78235-5214					<b>8. PERFORMING ORGANIZATION REPORT</b>	
<b>9. SPONSORING / MONITORING AGENCY NAME(S) AND ADDRESS(ES)</b> Air Force Research Laboratory 711 Human Performance Wing Human Effectiveness Directorate Directed Energy Bioeffects Optical Radiation Branch Brooks City-Base, TX 78235-5214					<b>10. SPONSOR/MONITOR'S ACRONYM(S)</b> 711 HPW/RHDO	
					<b>11. SPONSOR/MONITOR'S REPORT NUMBER(S)</b> AFRL-RH-BR-TR-2011-0007	
<b>12. DISTRIBUTION / AVAILABILITY STATEMENT</b> Pending Distribution A: Approved for public release; distribution unlimited (approval given by local Public Affairs Office PA# 11-112)						
<b>13. SUPPLEMENTARY NOTES</b>						
<b>14. ABSTRACT</b> Five-axis goniometric stages have been used in laser eye safety research for over forty years. The stages are able to translate in three dimensions and rotate about either eye of a prone-placed subject. This report describes the design, implementation, and operation of a five-axis goniometric stage. The latest design incorporates many ideas from previous versions while adding reliability and functionality improvements, such as a position indicator option. Most notably, the current design merges the rotary and linear portions into a single contained motion system. A manual control box facilitates the operation of the two rotational axes and three linear travel axes. The design criteria for the goniometric portion of the stage nominally called for ±15 degrees pitch adjustment and ±40 degrees of rotational adjustment. The XY section was designed for 6.5 inches (16.5 cm) of travel in each axis. The height stage section was required to have 8 inches of range with a center of motion approximately 46 inches above the floor.						
<b>15. SUBJECT TERMS</b>						
<b>16. SECURITY CLASSIFICATION OF:</b>			<b>17. LIMITATION OF ABSTRACT</b>	<b>18. NUMBER OF PAGES</b>	<b>19a. NAME OF RESPONSIBLE PERSON</b>	
<b>a. REPORT</b>	<b>b. ABSTRACT</b>	<b>c. THIS PAGE</b>			<b>19b. TELEPHONE NUMBER (include area code)</b>	
U	U	U	SAR	101	NA	

**Standard Form 298 (Rev. 8-98)**  
Prescribed by ANSI Std. Z39.18

**This Page Intentionally Left Blank**

# TABLE OF CONTENTS

TABLE OF CONTENTS.....	iii
LIST OF TABLES .....	iv
TABLE OF FIGURES .....	v
1 INTRODUCTION.....	1
2 DESIGN AND IMPLEMENTATION .....	2
2.1 Stage Description .....	2
2.2 Goniometric Section.....	2
2.2.1 Pitch Axis.....	2
2.2.2 Rotation Axis .....	7
2.3 In / Out and Left / Right Section .....	9
2.4 Height Section .....	12
2.5 Mobile Base Section.....	14
2.6 Motion Control Electronics Section.....	15
2.7 Position Feedback Electronics Section .....	20
3 USER OPERATION .....	25
4 TESTING.....	28
4.1 DC-DC LVDT Linearity .....	28
4.2 Hysteresis and Repeatability .....	30
5 MAINTENANCE.....	38
6 GLOSSARY .....	39
7 Appendix A: Electrical Drawings.....	40
8 Appendix B: Mechanical Drawings .....	43

## LIST OF TABLES

Table 1: Telesmart pillar TXG Specifications .....	12
Table 2: List of Connectors.....	17
Table 3: Pin Assignments for 44 pin card edge connector .....	18
Table 4: Recommended products for screw jack lubrication.....	38

## TABLE OF FIGURES

Figure 1: The fully-assembled stage .....	1
Figure 2: The screw jack framework assembly supports the subject platform.....	3
Figure 3: Close-up view of screw jack and screw jack framework assembly .....	4
Figure 4: The EL jack pivot bracket depresses a limit switch once the maximum pitch angle has been reached .....	5
Figure 5: The male clevis end of the screw jack lead-screw is locked onto a clevis mount plate on the elevation bottom support platform .....	5
Figure 6: The front of the subject platform lies between the arc-slides and ear bar holders .....	6
Figure 7: Overhead view of front side of five-axis stage.....	6
Figure 8: Back side of five-axis stage.....	7
Figure 9: Rotation axis motor and linear stage .....	8
Figure 10: The AZ drive shaft slides through the AZ shaft holder as the carriage travels along the linear stage .....	9
Figure 11: CAD representation of the fully assembled XY axes (LVDT position sensors are not shown) .....	10
Figure 12: Top view of axis bottom plate with the gear motor, drive shaft, drive nut, limit switches, linear bearing support shafts, and position transducer .....	11
Figure 13: The linear bearings are mounted on the linear bearing support shafts .....	11
Figure 14: Telesmart telescopic pillar.....	12
Figure 15: Diodes added for pillar reversal .....	13
Figure 16: Arrows show the locations of the added switches.....	13
Figure 17: CAD model of the mobile base .....	14
Figure 18: Control electronics schematic .....	16
Figure 19: Cabling connections .....	17
Figure 20: Completed electronics box .....	18
Figure 21: Remote control .....	20
Figure 22: Readout Remote .....	21
Figure 23: Rotation Axis' Position Sensor Offset Adjustment Circuit.....	22
Figure 24: LVDT coil assembly mounting .....	23
Figure 25: Pitch transducer .....	23
Figure 26: Rotational axis position sensor.....	24
Figure 27: Alignment jig.....	25
Figure 28: Location front adjustments.....	26
Figure 29: Clevis mounting plate.....	27
Figure 30: DC-DC LVDT test circuit .....	29
Figure 31: DC-DC LVDT Linearity Test 1 .....	29
Figure 32: DC-DC LVDT Linearity Test 2 .....	29
Figure 33: DC-DC LVDT Linearity Test 3 .....	30
Figure 34: Setup for hysteresis and repeatability measurements.....	31
Figure 35: Rotational Axis Positive Direction Hysteresis .....	32
Figure 36: Rotational Axis Negative Direction Hysteresis.....	32

Figure 37: Rotational Axis Positive Direction Repeatability .....	33
Figure 38: Rotational Axis Positive Direction Combined Repeatability .....	33
Figure 39: Rotational Axis Negative Direction Repeatability .....	34
Figure 40: Rotational Axis Negative Direction Combined Repeatability .....	34
Figure 41: Pitch Axis Positive Direction Hysteresis.....	35
Figure 42: Pitch Axis Negative Direction Hysteresis .....	35
Figure 43: Pitch Axis Positive Direction Repeatability .....	36
Figure 44: Pitch Axis Positive Direction Combined Repeatability .....	36
Figure 45: Pitch Axis Negative Direction Repeatability .....	37
Figure 46: Pitch Axis Negative Direction Combined Repeatability.....	37
Figure 47: Pitch and rotation wiring .....	41
Figure 48: In/Out and Left/Right wiring.....	42
Figure 49: Goniometric Section.....	43
Figure 50: XYZ Section.....	44
Figure 51: Mobile Base Section.....	45
Figure 52: Elevation Platform.....	46
Figure 53: Elevation Left Arc Support .....	47
Figure 54: Elevation Right Arc Support .....	48
Figure 55: Elevation Bottom Support Platform .....	49
Figure 56: Elevation Arc Left .....	50
Figure 57: Elevation Arc Right.....	51
Figure 58: Elevation Cross Slide Top.....	52
Figure 59: Elevation Cross Slide Bottom .....	53
Figure 60: Elevation Cross Slide Clamp.....	54
Figure 61: Elevation Top to Bottom Connector Plate .....	55
Figure 62: Elevation Bottom Support Column .....	56
Figure 63: Elevation Side Pivot Bracket.....	57
Figure 64: Elevation Jack Pivot Bracket.....	58
Figure 65: Elevation Jack Mount Bracket .....	59
Figure 66: Elevation Motor Support Bracket.....	60
Figure 67: Elevation Motor Bracket Bottom .....	61
Figure 68: Elevation Motor Bracket Top.....	62
Figure 69: Elevation Clevis Shaft Bracket.....	63
Figure 70: Elevation Clevis Shaft.....	64
Figure 71: Elevation Clevis Mount Plate.....	65
Figure 72: Ear Bar Holder.....	66
Figure 73: Ear Bar Holder Guide.....	67
Figure 74: Ear Bar Vertical Rod .....	68
Figure 75: Chin Rest Mount .....	69
Figure 76: Chin Rest Support .....	70
Figure 77: Cornea Alignment Jig Support .....	71
Figure 78: Cornea Alignment Jig Cross Support.....	72
Figure 79: Azimuth Rotation Mount.....	73
Figure 80: Azimuth Rotation Mount Column.....	74
Figure 81: Azimuth Base Platform .....	75
Figure 82: Azimuth Velmex Stage Base.....	76

Figure 83: Azimuth Velmex Stage Platform .....	78
Figure 84: Azimuth Shaft Holder .....	78
Figure 85: Azimuth Linear Bearing Mount .....	79
Figure 86: Azimuth Pivot Lower Bearing .....	80
Figure 87: Azimuth Drive Motor Adapter .....	81
Figure 88: Azimuth Drive Motor Shaft Adapter.....	82
Figure 89: XY Stage Top Plate.....	83
Figure 90: XY Stage Base Plate.....	84
Figure 91: XY Motor Mount.....	85
Figure 92: XY Acme Nut Mount.....	86
Figure 93: XY Acme Nut Mount Bracket.....	87
Figure 94: XY Acme Shaft Support.....	88
Figure 95: XYZ Pillar Mount Plate .....	89
Figure 96: XY Acme Shaft Modification .....	90
Figure 97: Mobile Base Top Plate .....	91

**This Page Intentionally Left Blank**

# 1 INTRODUCTION

Laser eye safety researchers have desired to precisely image a subject's eye *in vivo*. To achieve this end, the five-axis goniometric stage was designed and built. The stage gives the user control of five directions of motion to aid in positioning the subject before an imaging system. The current stage version, described in this report, is the fifth generation goniometric stage. Previous designs of the stage lacked precise motion, mobility, and accuracy, resulting in decreased efficiency during experiments. The fifth generation stage was designed with the following design requirements: approximately +/- 15 degrees of pitch adjustment and approximately +/- 40 degrees of rotational adjustment, 6.5 inches (16.5 cm) of left/right and in/out translation for fine tuning of XY position, and 8 inches (20 cm) of vertical travel. In addition, the stage was designed to be mobile and to bear the weight of a subject (up to 22.7 kg) on a platform while maintaining precise movements. Independent control of each axis with simultaneous multiple axis actuation was required.



**Figure 1: The fully-assembled stage**

## 2 DESIGN AND IMPLEMENTATION

### 2.1 Stage Description

All mechanical components and electronic controls on the five-axis stage are integrated so that the stage functions as a standalone unit. The system consists of six sections. The first and most important is the goniometric section. This section has two rotational axes that are goniometric about a point 0.375 inches (0.9525 cm) from the front edge of the stage and 2.8 inches (7.112 cm) above the subject platform when the platform is mounted in its highest position. The second section is an XY stage that allows positioning of the goniometric section with respect to the observation instrument. The XY stage accomplishes the left-right and in-out movements of the stage assembly. The third section is the height adjustment. The height section enables translation of the working height of the entire five-axis stage assembly. The fourth section is a mobile base that allows the stage to be easily transported and locked in its operational position for an experiment. The fifth section consists of the motion control electronics, which adjust the speed and direction of all stage axes. An optional sixth section, the position feedback electronics, gives the operator positional information. This final section includes sensors on four axes: the goniometric axes, the left-right axis, and the in-out axis. Sensor outputs are visible on a tethered remote control panel with numerical displays indicating relative position for each instrumented axis.

### 2.2 Goniometric Section

#### 2.2.1 Pitch Axis

The pitch axis of this stage system was designed to nominally have +/- 15 degrees of rotation. The rotation of the stage section is goniometric about a point 2.8 inches (7.1 cm) above the subject platform (Figure 52) when mounted in the highest position or 3.3 inches (8.4 cm) when mounted at the other extreme. The subject platform can be lowered on the arc one-half inch (1.27 cm) to accommodate larger subjects. If this lower position is chosen the limits of rotation are altered and an adjustment of the limit switches for this axis is required. This axis uses two arc-slides (figures 6, 7, 53, 54, 56, and 57) to control the goniometric rotation. The drive for this axis is an off-the-shelf screw jack actuator. The screw jack is connected to the subject platform and the bottom support platform (Figure 55) for the pitch axis.

**An adjustable chin support (Figure 75) is included that allows the subject's chin to be raised or lowered to enable proper subject alignment. Two orthogonal lines are engraved on the subject platform and chin support. The engraved line which is parallel to the front-to-back axis of the subject platform is designed to give the user a guide to center the subject on the stage. The plane of rotation is normal to the engraved line that is orthogonal to the subject platform's front-to-back axis. This plane intersects the rotational axis of the pitch stage section. The subject should be mounted with its head centered on the stage and apexes of its corneas aligned with the plane of rotation. The apex of the cornea of interest can then be aligned to the rotation axis with the dovetail slide (figures 58, 59, and 60) located below the subject platform. Ear bar holders are included to assist with**

**holding the subject in position. The ear bar holders with adjustment knobs are attached to the subject platform. An optional position feedback sensor (**

Figure 8) on the pitch axis of the stage can be installed to output a DC voltage proportional to the angle of rotation.

**The screw jack actuator (WJ250I4S-12-STDX-STDX-X, Dayton Joyce, see**

**Figure 2) is driven by a brushless DC gear motor (BLWRPG172S-24V-4200-R3.8, Anaheim Automation, see**

**Figure 3). The gear motor is a 4200-RPM motor with an integral 3.8 to 1 planetary gear reducer. The range of motion of the screw jack actuator is bounded by two limit switches mounted to the side pivot bracket (**

**Figure 4). These limit switches restrict the range of motion of this axis to approximately +/- 20 degrees of travel. The rate of travel of this axis is controlled by a brushless DC motor controller (MDC050-050051, Anaheim Automation). The controller is capable of driving the pitch axis at a rate of 2 degrees per second. The stall speed for this axis is approximately 0.04 degrees per second. The rate of travel is adjusted with the pitch potentiometer (R4) on the motion control remote (**

Figure 21). The direction of travel is controlled with the pitch switch (S1) on the same remote.

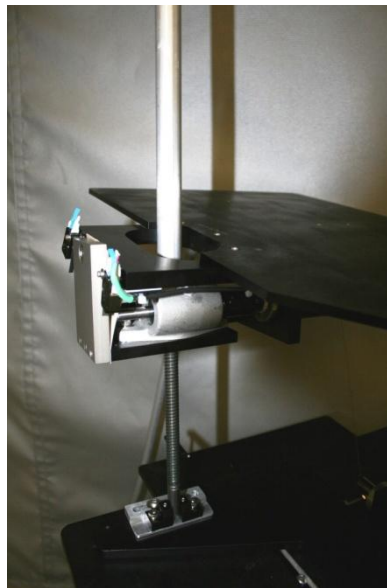

**Figure 2: The screw jack framework assembly supports the subject platform**

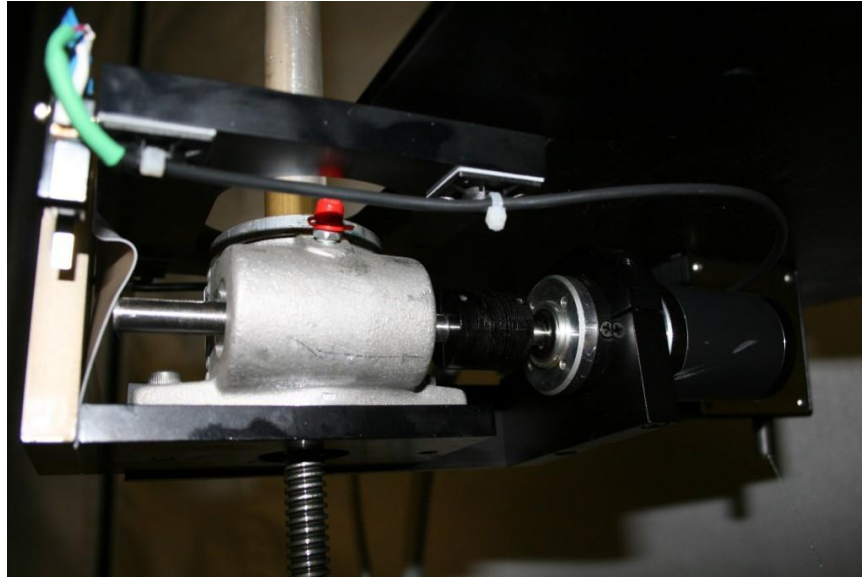
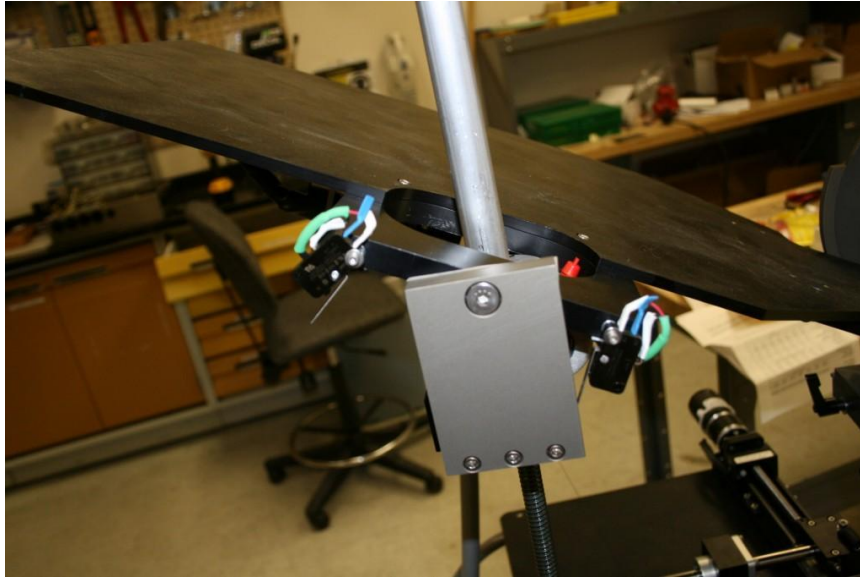

Figure 3: Close-up view of screw jack and screw jack framework assembly

The screw jack mounting framework consists of several components: a motor mount, a motor support bracket (figures 66, 67, and 68), the jack mount bracket (Figure 65), and the jack pivot bracket (Figure 64). The screw jack, its mounting framework, and its motor are collectively referred to as the screw jack assembly, and are rigidly fixed to one another. The screw jack assembly is connected to the elevation platform by the side pivot bracket (Figure 63) and the jack pivot bracket. The jack pivot bracket is locked onto a pivot point on the side pivot bracket with a shoulder bolt. The jack pivot bracket can freely rotate about this point, allowing the screw jack assembly to pivot relative to the subject platform. The screw-jack-actuator's lead screw has a female clevis end which is connected to the clevis mounting plate (Figure 71). The clevis mounting plate connects this assembly to the pitch's bottom support platform (Figure 55). The clevis mounting plate not only connects the actuator to the bottom support platform but also allows movement of the pitch axis 1.13 inches left or right to facilitate alignment of the subject's cornea to the rotation axis. This left-to-right motion is controlled by the dovetail slide assembly mentioned above. The slide position can be changed by loosening the adjustable L-shaped handles below the arc slide assembly and loosening the bolt that locks the clevis mounting plate to the bottom support platform (

Figure 5). The pivot point for the rotation axis is contained in the dovetail slide assembly.



**Figure 4: The EL jack pivot bracket depresses a limit switch once the maximum pitch angle has been reached**

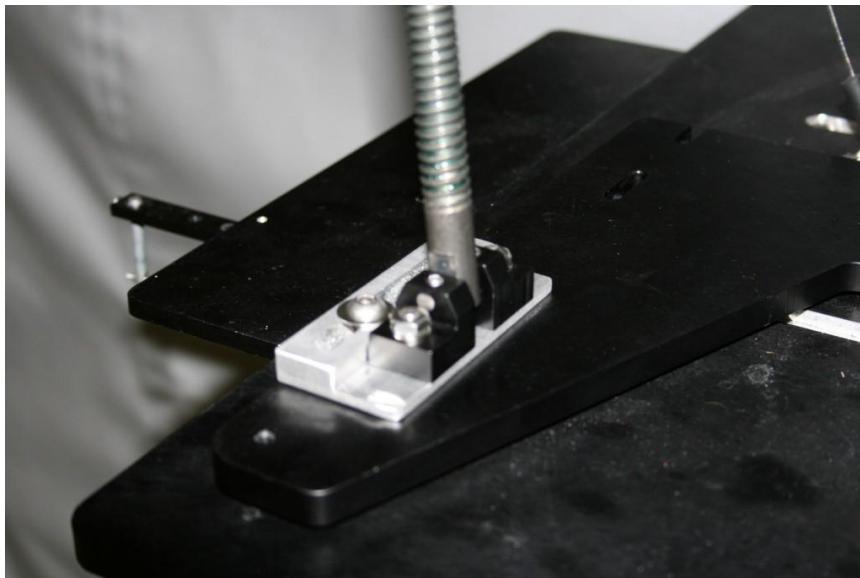

**Figure 5: The male clevis end of the screw jack lead-screw is locked onto a clevis mount plate on the elevation bottom support platform**

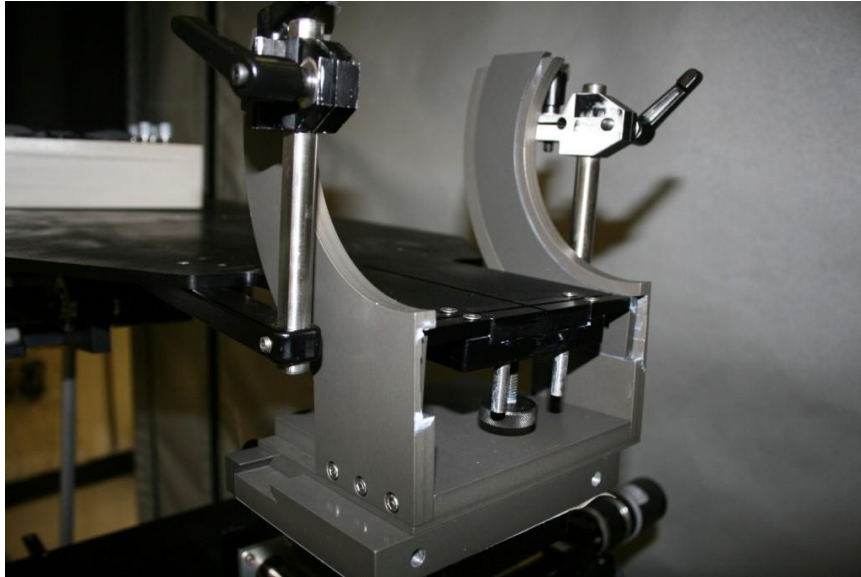

**Figure 6: The front of the subject platform lies between the arc-slides and ear bar holders**



**Figure 7: Overhead view of front side of five-axis stage**



**Figure 8: Back side of five-axis stage**

### **2.2.2 Rotation Axis**

**The rotation axis was designed to nominally have +/- 40 degrees of rotation. A pivot point located 0.375 inches (0.9525 cm) from the front of the stage establishes the rotational axis. The rotation is accomplished with an off-the-shelf linear stage (**

**Figure 9). The linear motion is converted into an arced motion by a linear bearing connected to a pivot that is attached to the bottom support platform for the pitch axis. The linear bearing slides on a hardened shaft that is rigidly mounted to the linear stage (**

**Figure 10). When the motor drives the linear stage, it drives a shaft left to right which causes the linear bearing to travel in and out on the shaft as the axis rotates. This assembly rotates the entire pitch axis around the front pivot point. An optional position feedback sensor (**

Figure 10) on the rotation axis of the stage can be installed to output a DC voltage proportional to the angle of rotation.

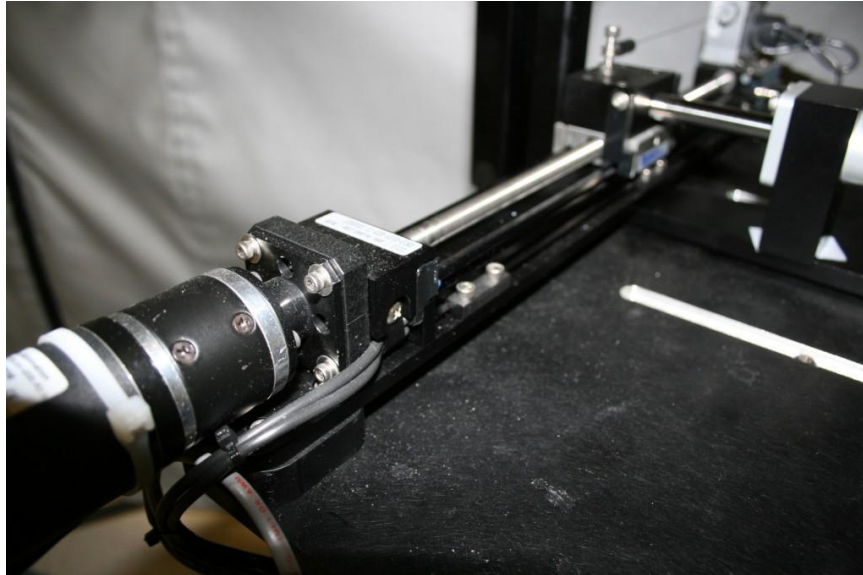
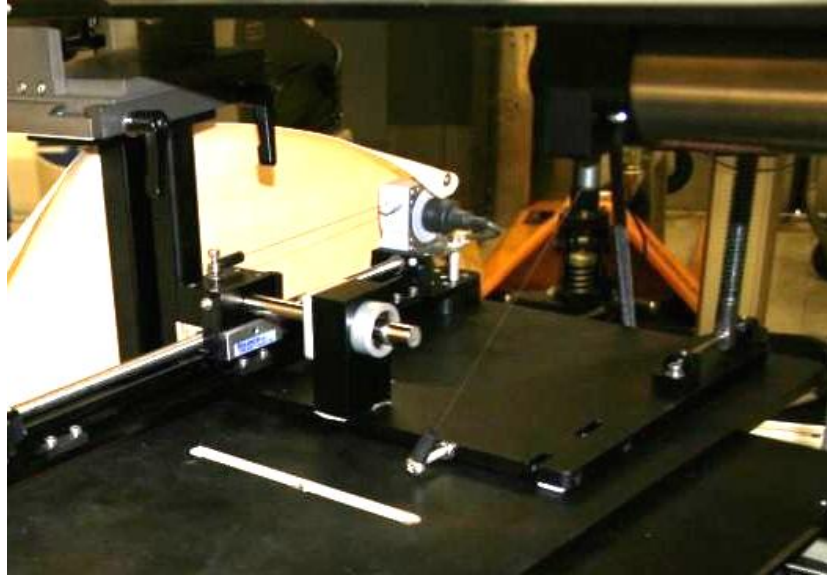

**Figure 9: Rotation axis motor and linear stage**

**The linear stage (XN10-0120-E25-71, Velmex, Inc.) is driven by a brushless DC gear motor (BLWRPG172S-24V-4200-R3.8, Anaheim Automation, see**

Figure 10). The gear motor is a 4200-RPM motor with an integral 3.8 to 1 planetary gear reducer. The linear stage has a travel range of 12 inches (30.5 cm), which is reduced by 0.5 inches (1.27 cm) by two 0.25 inch (0.635 cm) flags. Integrated limit switches on the linear stage with the flags confine the range of motion of this axis to approximately +/- 40 degrees of travel. The rate of travel of this axis is controlled by a brushless DC motor controller (MDC050-050051, Anaheim Automation). The controller is capable of driving this axis at 4 degrees per second. The stall speed for this axis is approximately 0.16 degrees per second. The rate of travel is adjusted with the rotation potentiometer (**R6**) on the motion control remote. The direction of travel is controlled with the rotation switch (**S2**) on the same remote.

The motion of the linear stage drives the rotational arc. In order to accomplish this arced motion, the shaft holder (Figure 84) is mounted to the linear stage carriage. A hardened shaft is then mounted to the shaft holder. A linear bearing slides on this hardened shaft. The linear bearing is connected to a pivot point by the linear bearing mount (Figure 85), and the pivot lower bearing (Figure 86). The pivot point attaches to the pitch axis' bottom support platform (Figure 55). The bottom support column (Figure 62) joins the front of the pitch axis' bottom support platform to the dove tail slide. The dove tail slide pivots on a shoulder bolt connected to the rotation mount (Figure 79). The rotation mount is attached to a column (Figure 80) that connects them to the base of the rotational axis (Figure 81). Consequently, the stage's rotational axis is a vertical line passing through the corneal rotation point.



**Figure 10: The AZ drive shaft slides through the AZ shaft holder as the carriage travels along the linear stage**

### **2.3 In / Out and Left / Right Section**

The in / out and left / right axes were designed to have +/- 3.25 inches (8.3 cm) of travel in each direction. The section is referred to as the left/right and in/out section on the stage. This nomenclature was adopted to eliminate confusion with movement directions on the retina. The in / out and left / right axes are mounted between the pitch and rotation axes, and the height axis. Each axis uses a custom-made motorized linear slide assembly to achieve the necessary range of motion. These linear slides are driven with an Acme style threaded rod. The linear motion is controlled with linear bearings sliding on hardened shafts. Optionally, these axes of the stage can include a position feedback sensor which outputs a DC voltage proportional to the distance traveled.

**Each linear slide is driven by a brushless DC gear motor (BLWRPG111S-24V-2700-R14, Anaheim Automation, see**

Figure 12). The gear motor is a 2700-RPM motor with an integral 14 to 1 planetary gear reducer. The range of motion of each axis is constrained by two limit switches mounted to one of the linear bearing support shafts for the axis. Rate of travel is controlled by a brushless DC motor controller (MDC050-050051, Anaheim Automation). The controller is capable of driving these axes at 0.2 inches (0.5 cm) per second. The stall speed for these axes is approximately 0.02 inches (0.05 cm) per second. The rate of travel is adjusted with the in/out left/right potentiometer (**R7**) on the motion control remote. The direction of travel is controlled with the in/out switch (**S3**) and the left/right switch (**S4**) on the same remote.

The gear motors drive a stainless steel ultra-smooth 1/4"-20 threaded rod, which then drives a plastic drive nut designed for the rod. The drive nut is attached to the moveable plate for the axis. This combination supplies the driving force for the axis. Two hard anodized aluminum linear bearing support shafts are mounted to the fixed plate for the axis. These comprise the bottom half of the sliding mechanism of each axis. Each of the linear bearing support shafts has two pillow-block style self-aligning Frelon-lined linear bearings. The linear bearings are single-length open-type bearings. The linear bearings attach to the moveable plate of the axis. These make up the top half of the axis. Together, all these components ensure that the axes will have smooth linear motion with minimal side-to-side play (

Figure 11, 12, and 13). The drawings for the mechanical parts for this section are in figures 89 through 96.

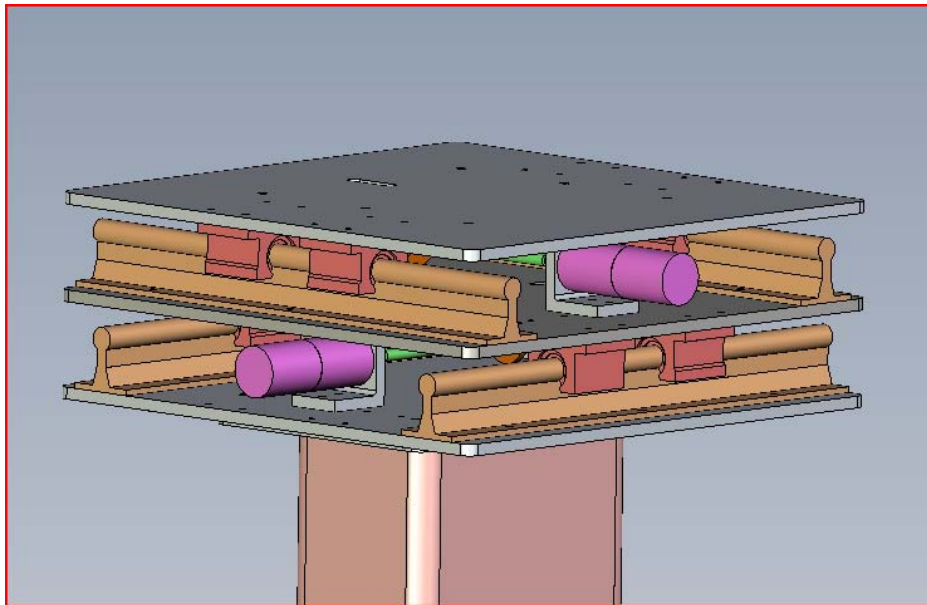

**Figure 11: CAD representation of the fully assembled XY axes (LVDT position sensors are not shown)**



**Figure 12: Top view of axis bottom plate with the gear motor, drive shaft, drive nut, limit switches, linear bearing support shafts, and position transducer**

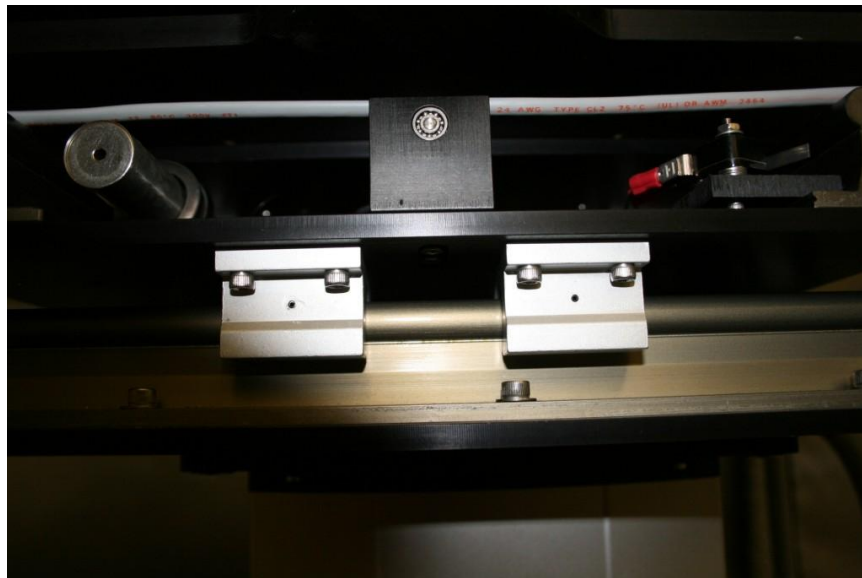

**Figure 13: The linear bearings are mounted on the linear bearing support shafts**

## 2.4 Height Section

The purpose of the height axis is to allow vertical positioning of the stage system. The axis is required to move a load of at least 50 pounds (22.7 kg) mounted on the subject platform and the combined weight of all the other components above it. The axis has a stroke of approximately 8 inches (20 cm). This axis is an off-the-shelf Telesmart TXG telescopic pillar (SKF, Figure 14). The pillar consists of two anodized aluminum profiles capable of applying 337.2 lbs (1500 N) of force. One profile fits inside the other, and the two are extended and retracted to create a linear actuator. The pillar is designed to extend and retract with minimal friction, even in the case of eccentric loads: it will also handle compressive loads. The driver of the actuator is a DC motor with a worm gear, which creates the linear motion by means of a driven nut system. The pillar requires no maintenance. For our application, the Telesmart telescopic pillar was modified. Two switches were added as limits, a diode (5A, 100 V PIV) was placed across each of these switches to allow the pillar to move past the limits (figures 15 and 16). The stroke of the actuator is limited by these switches. The speed of the height axis is controlled by a variable DC power supply (PS5). The variable power supply will allow a maximum of approximately 0.7 inches (1.8 cm) per second travel and a minimum of 0.05 inches (0.13 cm) per second.

**Table 1: Telesmart pillar TXG Specifications**

<b>Push Force</b>	1500 N (337.2 lb force)
<b>Maximum speed</b>	17-23 mm/s
<b>Stroke</b>	200 mm
<b>Weight</b>	9-14 kg



**Figure 14: Telesmart telescopic pillar**

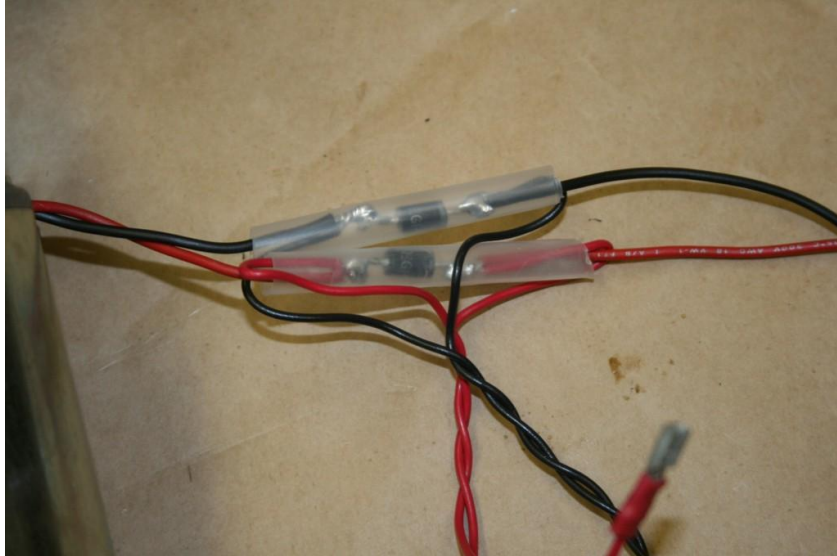

**Figure 15: Diodes added for pillar reversal**

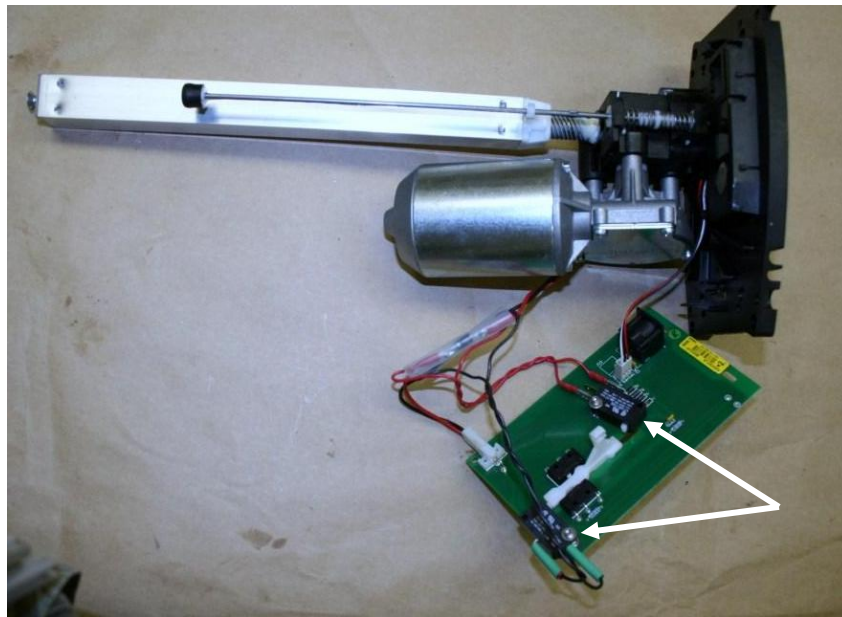
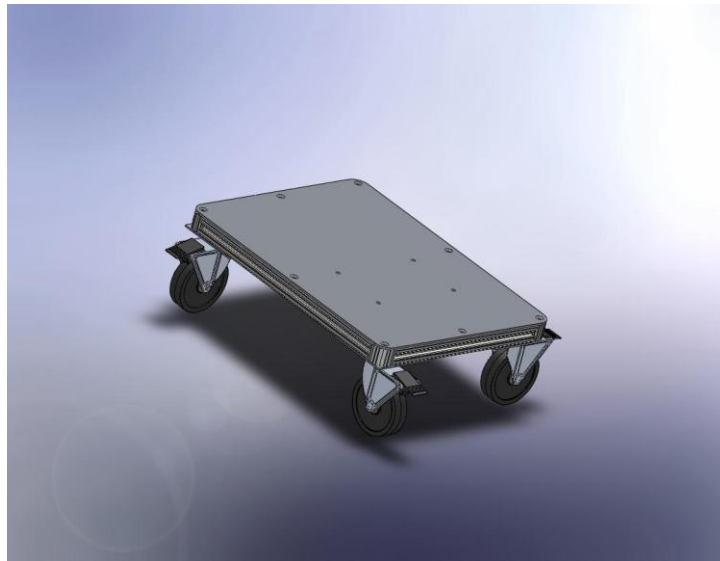

**Figure 16: Arrows show the locations of the added switches**

## 2.5 Mobile Base Section

The entire five-axis stage is mounted upon a mobile base. The base provides mobility, along with a secure and stable platform, for the stage. This base is assembled with an 80/20® frame and an anodized sheet metal plate. The entire stage is firmly attached to the base with 80/20® cross supports. Four casters support the mobile base and allow the stage to be easily maneuvered with respect to various instruments. The casters can be locked to inhibit stage movement during an experiment (

Figure 17).



**Figure 17: CAD model of the mobile base**

## 2.6 Motion Control Electronics Section

The electronics box houses the majority of the electronic components that provide control of the motion for the stage. This box contains the brushless DC motor controllers and the power supplies for all the axes. The stage is connected to the electronics box via five circular plastic connectors (CPC). A sixth CPC connects to the stage remote control box which houses the rest of the control electronics. The seventh CPC connects to the optional position display. Throughout the following section, when a connection is referenced with the notation of ex: P1-1, this corresponds to the connection that is made at connector 1, pin 1 etc. Refer to Figure 18: Control electronics schematic when components designations are mentioned.

The electronic control box is powered by 120 VAC 60 Hz and is fused at 6 amps. The connection to the electronics box is an IEC jack which contains the line fuses (F1 and F2), and the main power switch (S6). When the main power switch is turned on the 120 VAC provides power to the four 24 VDC 2.7 A power supplies (PS1-PS4, Anaheim Automation PSAM24V2.7A) and a custom built variable 24 VDC 5 A power supply (PS5). The input voltage to the variable power supply is delivered with a 24V centered tapped transformer (T1, 117 / 24 VCT, 8 A). The 24 VAC voltage is rectified by a full-wave bridge (D1, 8 A, 600 V PIV) which is filtered by capacitors C1 (1  $\mu$ F, 50 V tantalum) and C2 (100  $\mu$ F, 50 V electrolytic). The filter DC voltage is then fed into a five-ampere three-terminal variable regulator (U1, LM338K). The voltage output for the regulator is set by R1 (120  $\Omega$ , 0.5 W) and R2 (5 k $\Omega$ , 2.5 W potentiometer) which is filtered by C3 (1  $\mu$ F, 50 V tantalum). Diodes D2, D3, and D7 (1N4002) protect the three-terminal regulator from back EMF. PS1 through PS3 provide power for the four brushless DC motor controllers (Anaheim Automation, MDC050-050051). PS4 supplies power to the optional position sensors and digital position readouts. PS5 is used to control the height axis.

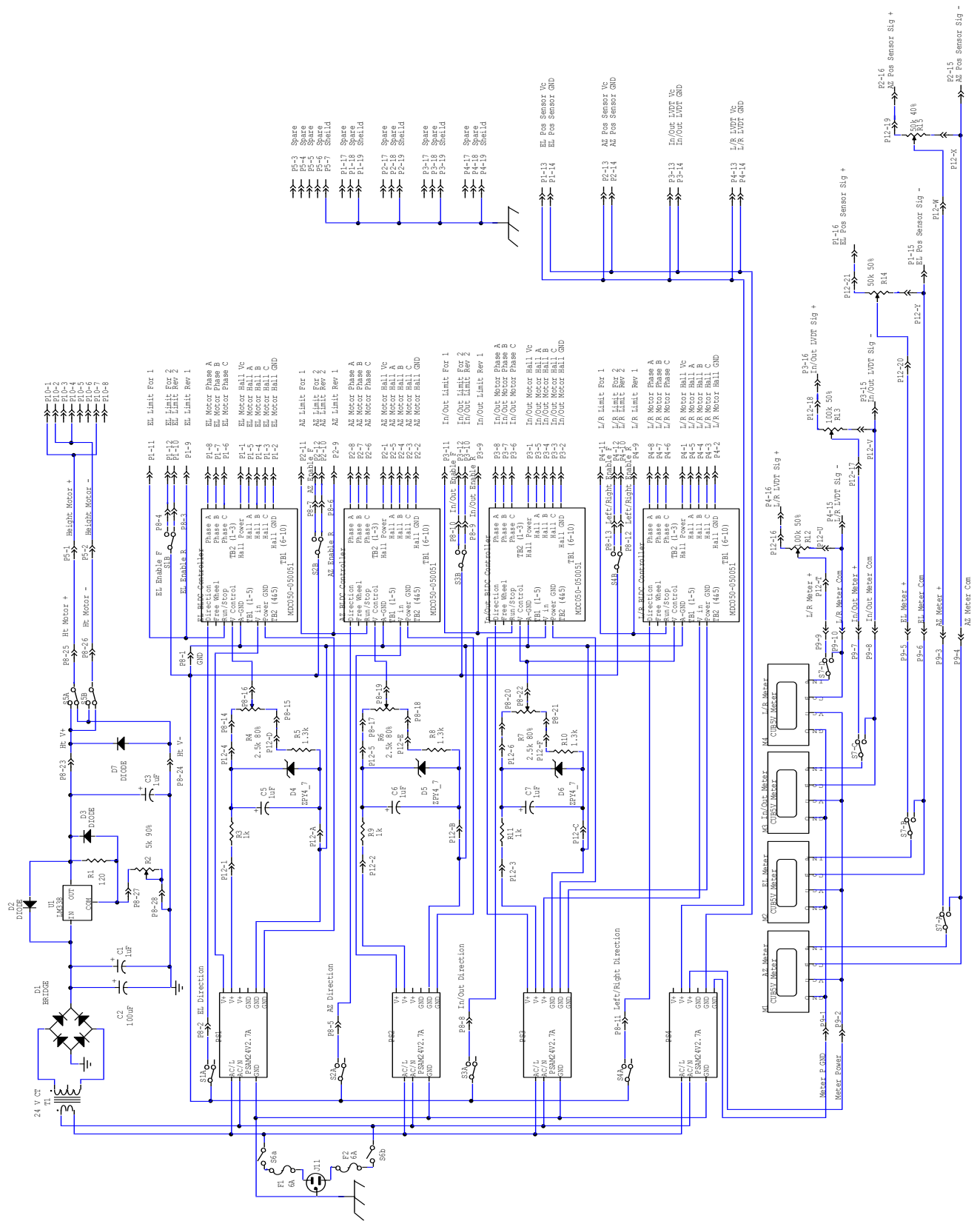

Figure 18: Control electronics schematic

**Table 2: List of Connectors**

Connector	Function
P1	Pitch Axis
P2	Rotational Axis
P3	In/Out Axis
P4	Left Right Axis
P5	Height Axis
P6	Pitch Axis Sensor
P7	Rotational Axis Sensor
P8	Remote Control
P9	Position Readout
P10	Telesmart Pillar
P11	AC Power
P12	Internal PCB
P13	Rotational Axis String Potentiometer



**Figure 19: Cabling connections**

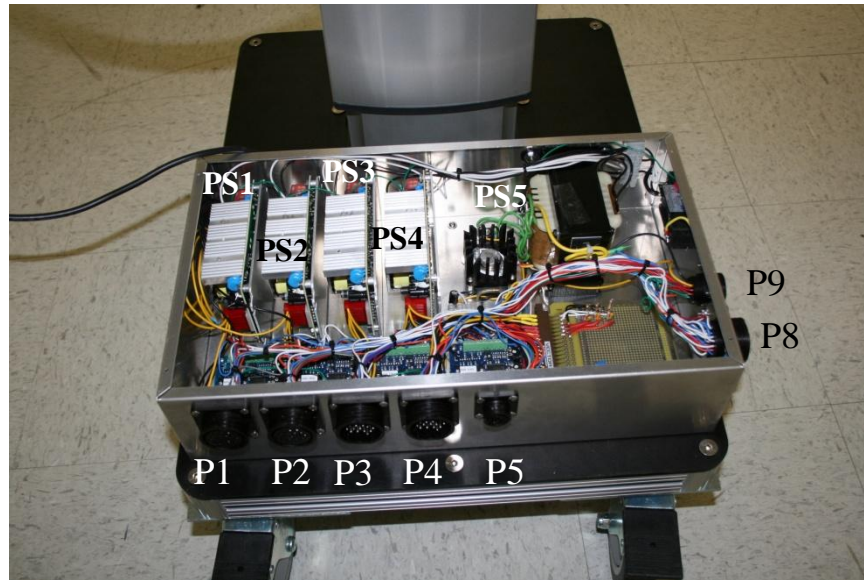

**Figure 20: Completed electronics box**

**Table 3: Pin Assignments for 44 pin card edge connector**

1	PS1 +24V	A	PS1 GND
2	PS2 +24V	B	PS2 GND
3	PS3 +24V	C	PS3 GND
4	R4 Hi	D	R4 Low
5	R6 Hi	E	R6 Low
6	R7 Hi	F	R7 Low
7		H	
8		J	
9		K	
10		L	
11		M	
12		N	
13		P	
14		R	
15		S	
16	R12 + (yellow)	T	R12 Center (orange/white)
17	R13 Center (blue/white)	U	R12 - (grey)
18	R13 + (purple)	V	R13 - (white)
19	R15 + (orange)	W	R15 Center (black)
20	R14 Center (blue)	X	R15 - (green)
21	R14 + (red)	Y	R14 - (brown)
22		Z	

The first two power supplies (PS1 and PS2) in the electronics control box power the brushless DC motor controllers (Anaheim Automation, MDC050-050051) for the pitch, and rotation axes. The third power supply (PS3) powers the in/out and left/right axes. The brushless DC motor controllers along with a DC source created by a zener diode with resistive divider (Pitch R3, R4, R5, D4 and C5; Rotation R9, R6, R8, D5 and C6; in/out and left/right R11, R7, R10, D6 and C7) set the rate of travel. The DC source supplies 1.88 to 4.7 volts to TB1-4 (VControl) of the axis' brushless DC motor controller. The potentiometers R4 (pitch), R6 (rotation), and R7 (in/out left/right) are mounted on the remote control box and set the speed of the axis. The fifth power supply (PS5) controls the speed of the height axis via R2 (height) which is also mounted on the remote control box. A series of five spring-loaded double-pole double-throw center-off rocker switches control the direction of the axes (Pitch S1; Rotation S2; In/Out S3; Left/Right S4; and Height S5).

The brushless DC motor controllers supply all the necessary control signals to the brushless DC motors that drive the pitch, rotation, in/out, and left/right axes. The controllers supply the three-phase power to motors through pins 6 to 8 of each axis' connector (P1 pitch, P2 rotation, P3 in/out, and P4 left/right). Each axis has hall-effect sensors that are used as feedback to control the speed of the axis. These sensors are connected to the controllers through pins 3 to 5 of the same connectors. Power and ground connections for these sensors are connected to pins 1 and 2 of these connectors respectively. One side of the limit switches for all these axes are connected to the run/stop pin of the controller (TB1-3) through pin 11 (forward limit) and pin 9 (reverse limit). The other side of the limit switches (pins 10 and 12 of the axis connector) connect to the brushless DC controller's local analog ground through each axis' switch on the remote control. The local analog grounds are connected to the remote control through P8 pin 1. Pins 13 through 16 on these connectors are used to supply power to and return the position information from the position sensors, if they are installed. Pin 17 is the shield connection for the cable and pin 18 is not used.

The height axis is controlled through P5 and P10. The height axis actuator is driven by a standard DC motor. Pin 1 of this connector is connected to the positive and pin 2 is connected to the negative sides of the motor. The direction of travel is controlled by switch S5 on the remote control. The switch supplies the correct polarity to drive the actuator up or down.



Figure 21: Remote control

The remote control box is connected to the stage motion control box through connector P8. All of the speed control potentiometers are mounted in the box at the top on the remote. There are two columns of switches that activate and control the direction of the stages. The left column controls the pitch and rotation axes. The right column controls the in/out, left/right, and height axes. All of these switches are spring-loaded center-off double-pole double-throw rocker switches. When the user releases a switch, it will return to its off position. The user can select any combination of these switches to create the desired motion. See

Figure 21 for the switch and potentiometer layout.

## 2.7 Position Feedback Electronics Section

The last major section of the stage is the position feedback electronics. The position feedback electronics is an optional part of this design. Its purpose is to supply the operator with positional feedback information. The position feedback electronics consists of three sections: the readout remote, which houses the four electronic displays that display the position information; the conditioning electronics, which set the scaling for the displays; and the sensors, which are mounted on each of the instrumented axes. The electronics control box contains the power and conditioning electronics for the position readouts and their sensors.

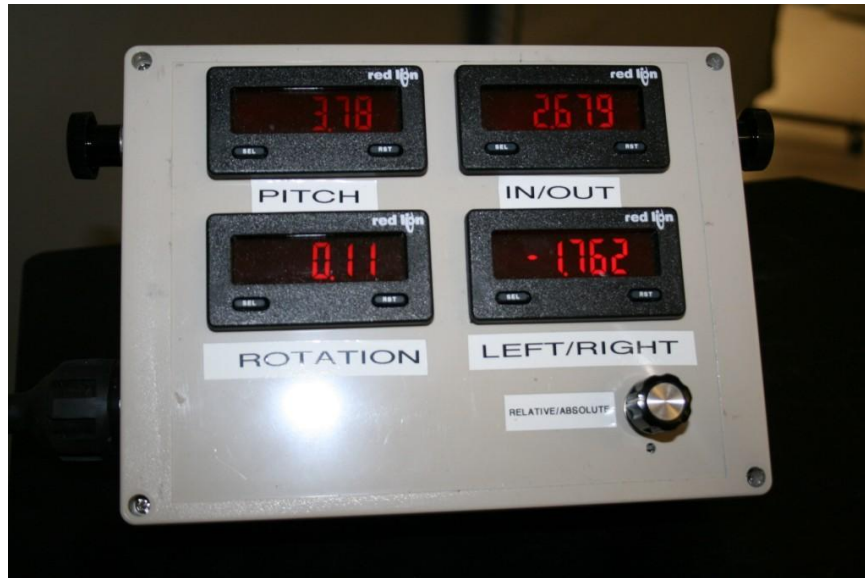
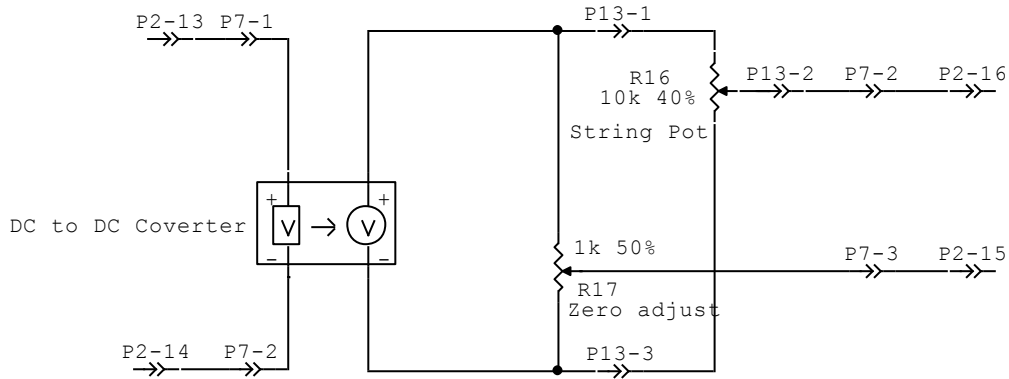

**Figure 22: Readout Remote**

The four electronic displays (Red Lion, CUB5V) get their power from PS4 in the electronics control box. The power is supplied to the readout remote through pins 1 (ground) and 2 (+24 V) of the connector P9. Each of the four meters has an electronic zero that can be used for relative movements. The zeroes can be reset by using the Relative/Absolute switch (S7) on the readout remote box. This switch grounds the inputs to all the meters so that the user can clear the relative position zeroes. It can also be used to determine what the relative offsets for zero are.

**The pitch axis' position information is displayed on meter M2. The position information for this axis comes from a string potentiometer mounted to the bottom of the subject platform. The string potentiometer is manufactured by Unimeasure Inc. and is model HX-P1010-15-SI (**

Figure 25). It has ranging and offset adjustments built in. As the string is extended from the potentiometer, a DC voltage proportional to the distance traveled is output. The scale is then calibrated by potentiometer R14 inside the electronics control box. Pins 5 (+) and 6 (common) of connector P9 carry the signal from the electronics control box to meter M2. The signal from the sensor is routed through P1-16 (sig +) and P1-15 (sig -). Power for the sensor is supplied through P1-13 (+24 V) and P1 14 (ground).

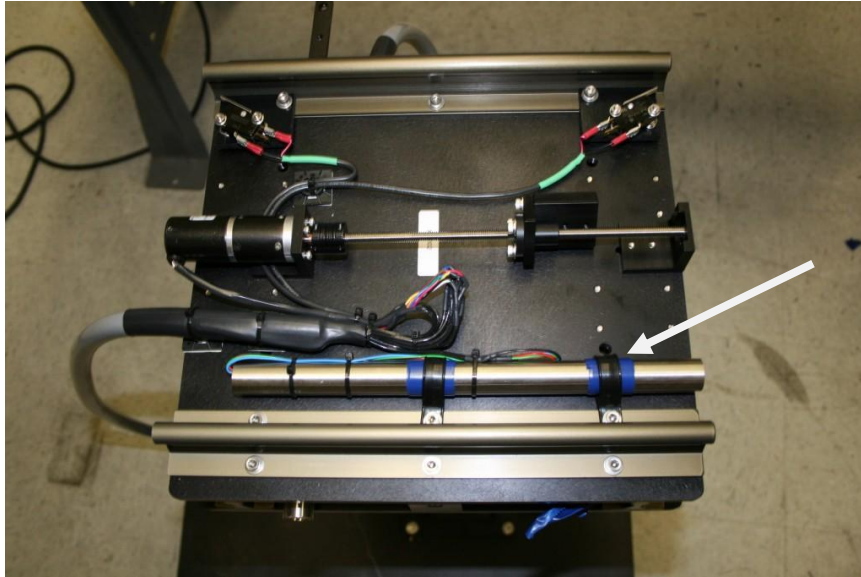

**Figure 23: Rotation Axis' Position Sensor Offset Adjustment Circuit**

**The rotational axis' position information is displayed on meter M1. The position information for this axis is developed from a string potentiometer mounted to the left side of the linear stage that drives the rotation axis of the stage. The string potentiometer is manufactured by Celesco Inc. and is a model SP2-12 (Figure 26). As the string is extended from the potentiometer a DC voltage proportional to the distance traveled is output.**

Figure 23 shows the circuit used to adjust the offset for centering the range of the displayed information. The scale is then calibrated by potentiometer R15 inside the electronics control box. Pins 3 (+) and 4 (common) of connector P9 carry the signal from the electronics control box to meter M1. The signal from the sensor is routed through P2-16 (sig +) and P2-15 (sig -). Power for the sensor is supplied through P2-13 (+24 V) and P2 14 (ground).

The in / out and left / right axes each use a DC-DC linear variable differential transformer (LVDT) (TransTek, 0246-00005) to measure the linear displacement of each axis. This position information is displayed on meters M3 and M4 respectively. An LVDT is comprised of a stationary coil assembly and a moveable rod. As the rod is displaced inside the coil assembly, it creates an output voltage change that is proportional to the change in position. The output voltages are scaled with potentiometers R13 (in/out) and R12 (left/right). The in/out transducer signals are routed from the axis through P3-16 (+ sig) and P3-15 (- sig) into the electronics control box and then to the readout remote after scaling through P9-7 (+) and P9-8 (common). Left/right transducer signals are routed similarly except that P4-16 and P4-15 carry the signal from the axis. Connector P9 pins 9 (+) and 10 (common) carry the scaled signal from the electronics control box to the readout remote. The power for the DC-DC LVDT transducers is supplied through pins 13 (+24 V) and 14 (ground) of connectors P3 and P4.



**Figure 24: LVDT coil assembly mounting**

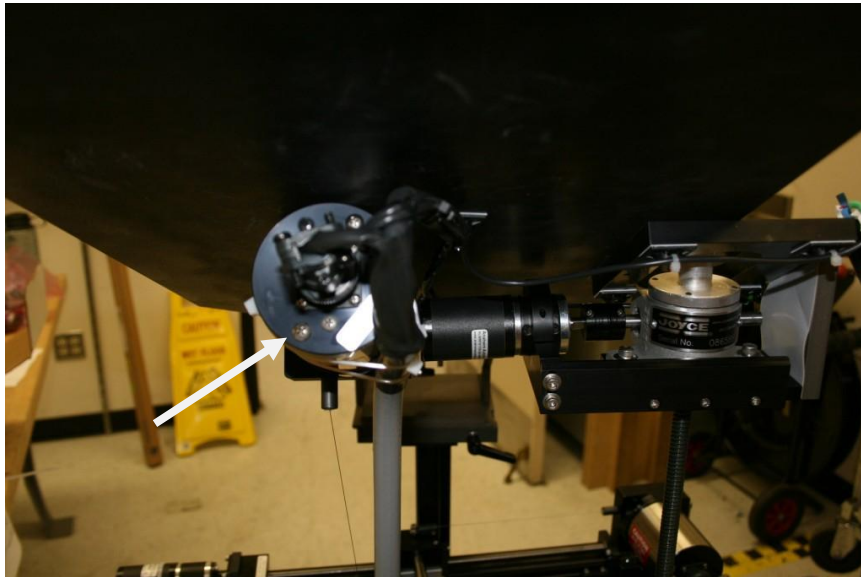

**Figure 25: Pitch transducer**

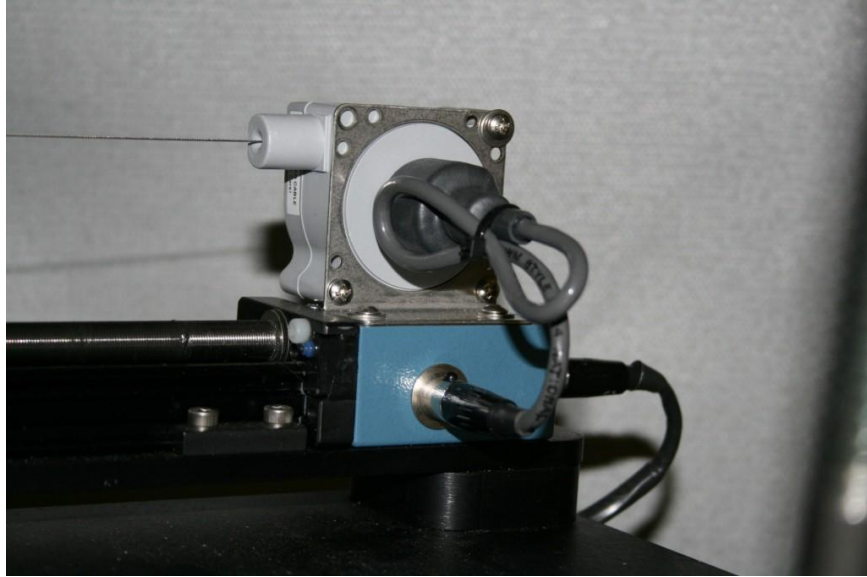
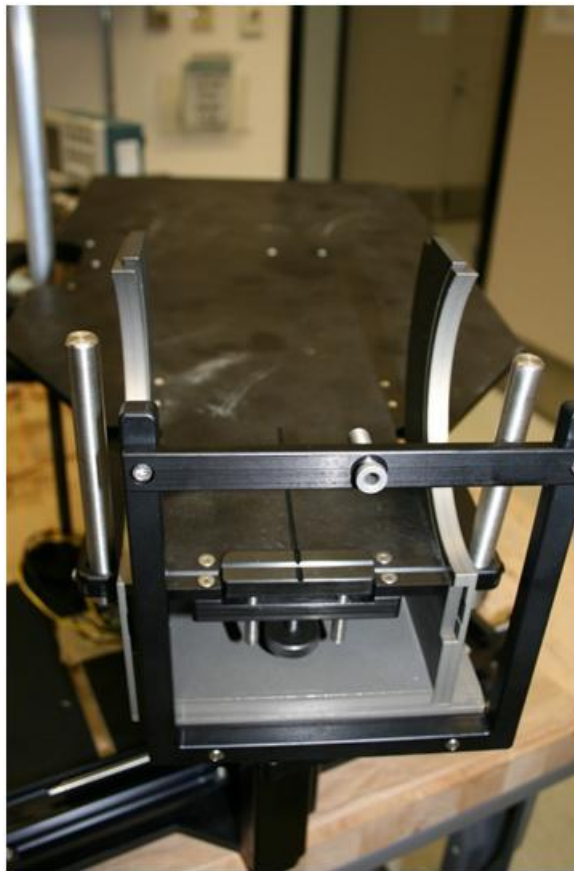

**Figure 26: Rotational axis position sensor**

### 3 USER OPERATION

**Warning: Do not pitch or rotate stage when alignment jig is in place; this could cause severe damage to the alignment jig or the stage itself.**

Day-to-day operation of the stage is straightforward. Power up the stage and begin with centering all axes except the height axis. For the pitch and rotation centering, it is critical to follow these procedures. The users should align the front of the arcs slides of the pitch axis with the front surface of the arc support; this is the precise center of travel for the pitch. The rotational axis should be aligned such that the cross slide bottom (Figure 59) and the rotation mount (Figure 79) are parallel. After this is done, position the stage in front of the imaging instrument and generally center the stage on the instrument. Lock the castors to hold the stage in place.

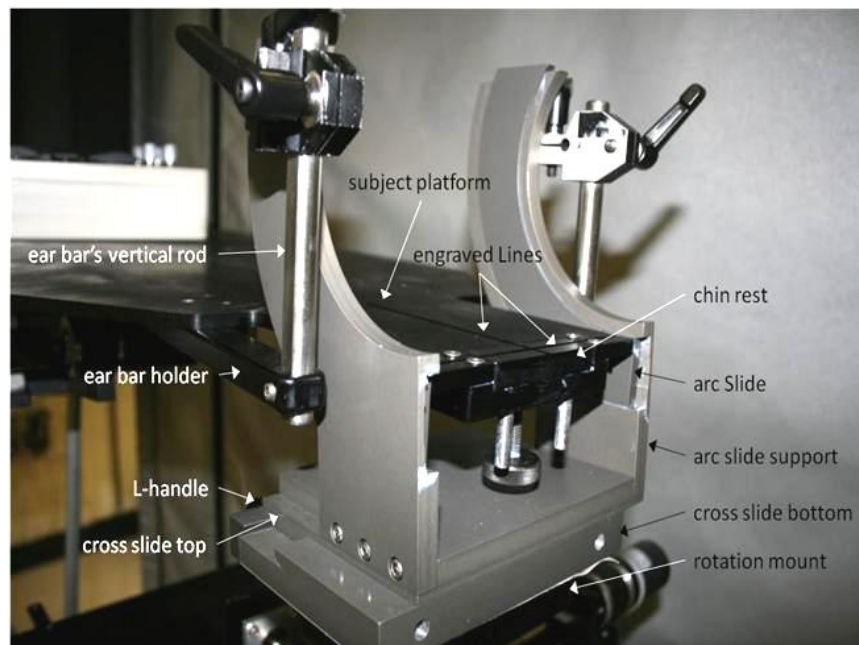

**Figure 27: Alignment jig**

**Install the alignment jig in the holes on the cross slide bottom (**

**Figure 27).** Warning: with the alignment jig installed do not engage the pitch or rotational axes; this could cause severe damage to the alignment jig or the stage itself. The alignment jig has a hollow tube at its top center. Using the left/right and height controls on the remote control, center the stage on the optical axis of the imaging instrument. The in/out axis may need to be adjusted out to allow subject placement. Remove the alignment jig temporarily. The next step is to mount the subject on the subject platform. Place the subject on the stage in a prone position on its stomach with its head centered on the line engraved down the center of the subject platform. Secure the subject with the ear bars or with some other method. Check to see if the apexes of the subject's corneas are aligned with the line engraved left-to-right across the subject platform (technically this should be the nodal point of the eye, which is difficult to identify visually). If they are not, loosen the ear bar holders and slide the subject front-to-back on the stage to align the apexes. Now reinstall the alignment jig being careful not touch the cornea with the alignment jig. Using the alignment jig loosen the two L-handles below the subject platform and the button head screw locking the clevis mounting plate to the bottom support platform (

Figure 29). With one arm under the subject platform and the other hand holding one of the arc supports, slide the subject platform left-to-right to align the cornea of the eye to be tested with the hollow tube on the alignment jig. Using the chin-rest adjustment or the ear holder's vertical rod, adjust the height of the subject's cornea to the height of the hollow tube. Remove the alignment jig. Tighten the L-handles and the button head screw that locks the clevis mounting plate.



**Figure 28: Location front adjustments**

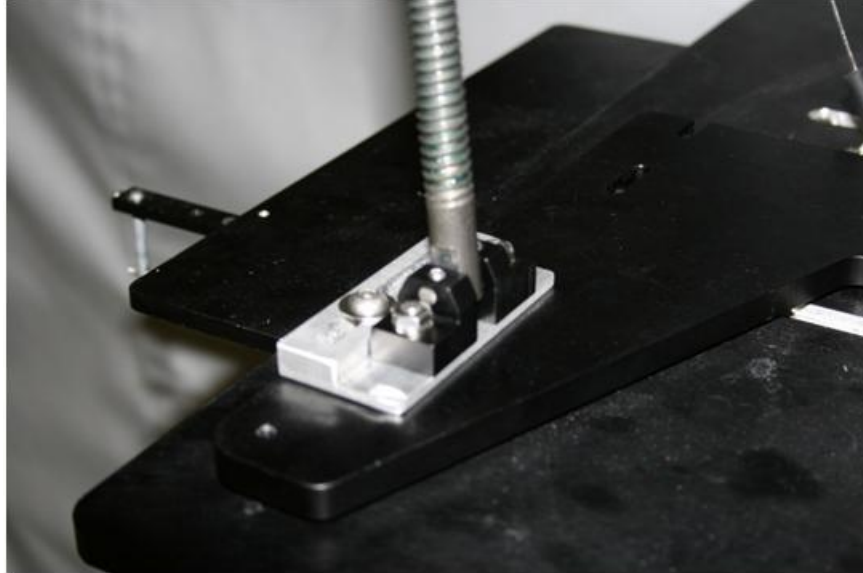

**Figure 29: Clevis mounting plate**

Once the subject is secure with its cornea located at the centers of rotations for both the pitch and rotation axes, the stage is ready for use. Using the in/out, left/right, and height adjustment, finely adjust the subject's cornea to the proper location for imaging. The speed control potentiometers should be used to slow the speed of the axes to facilitate these adjustments. When the cornea is at the correct location, the pitch and rotation adjustment can be used to pan the retina to the desired imaging location. If the cornea is not at the goniometric point of rotation, it may be necessary to adjust the left/right and height axes to maintain a center view of the retina. The rates of movement of the pitch and rotation can be adjusted with their respective speed control potentiometers.

It may become necessary to lower the subject platform for larger subjects. In order to perform this operation, the user should do the following: Center the pitch axis; power the stage down with the main power switch; disconnect P1, pitch-axis connector from the electronics control box. If equipped remove the screw connecting the string from the string potentiometer to the bottom support platform. Be careful not to let the string from the string potentiometer rapidly retract. This could permanently damage the string potentiometer. Remove the button head screw holding the clevis mounting plate to the pitch axis' bottom support platform. Next, remove the subject platform with the arc slides attached by rotating the subject platform upward. Lay the platform upside down on a flat surface. One arc at a time, remove the three screws attaching the arc slides. Move the screws to the lower set of holes in the arc. For now, just loosely tighten the screws. Repeat this for the other side. Flip the platform over. Check the alignment of the arcs with each other and the front of the subject platform. The front surface of these should all lie on in the same plane. Tighten all the screws holding the arcs. Verify that the front surfaces are still aligned. Reinstall the subject platform by reversing the procedure for removing it. Reattach the clevis mounting plate to the pitch axis' bottom

support platform with the button head that was removed earlier. Reconnect P1 to the electronics control box. Power the stage up. Watching for clearance between the subject platform and the rest of the stage, carefully and slowly pitch the stage down. Stop the pitch motion before the platform or anything attached to it makes contact with or binds on anything below it. Adjust the rear limit switch on the pitch axis to stop the pitch motion before this can occur to prevent damage to the stage. This will limit the total amount of downward pitch. If the user needs to undo this change repeat these steps after remounting the arcs on the upper set of holes.

The following is an abbreviated list of procedures for the use of the stage.

1. Power up the stage with the main power switch.
2. Center the following axes: Left / Right; Pitch; and Rotation
3. Center the stage coarsely for the experiment and lock the castors
4. Mount the subject on the stage.
5. Center the subject's cornea at the goniometric point using the alignment jig and scribed lines.
6. Precisely align the subject's cornea to the experiment.

## **4 TESTING**

### **4.1 DC-DC LVDT Linearity**

A series of three tests were performed to check the linearity of the DC-DC LVDT. The test circuit shown below uses the recommend components for operation with an input voltage of 24 volts and a load of 100 kilo ohms. The tests were accomplished by moving the core rod in half-inch steps and recording the voltage that corresponds to the position. The data from the tests are shown in the graphs below. In the first two tests, the core rod was moved in the opposite direction of the wires, and in the third and final test, the core rod was moved in the same direction of the wires, to check linearity in both directions. The results from the tests showed the DC-DC LVDT is indeed linear, as long as the rod is not extended too far from the transformer. In this design, the rod will be in constant proximity to the transformer thus maintaining linearity.

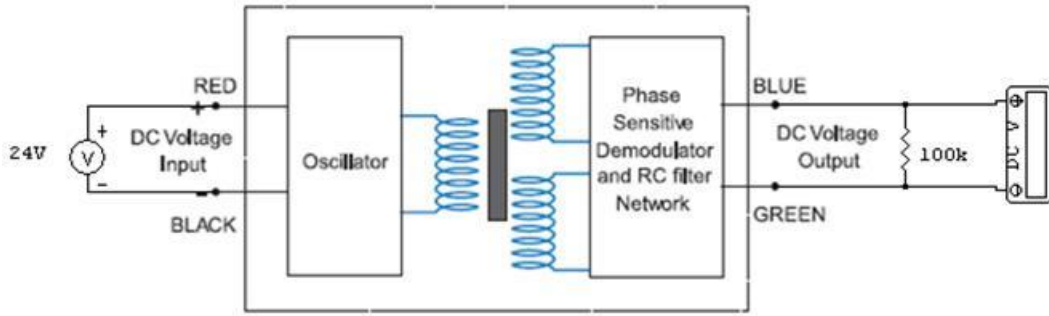

Figure 30: DC-DC LVDT test circuit

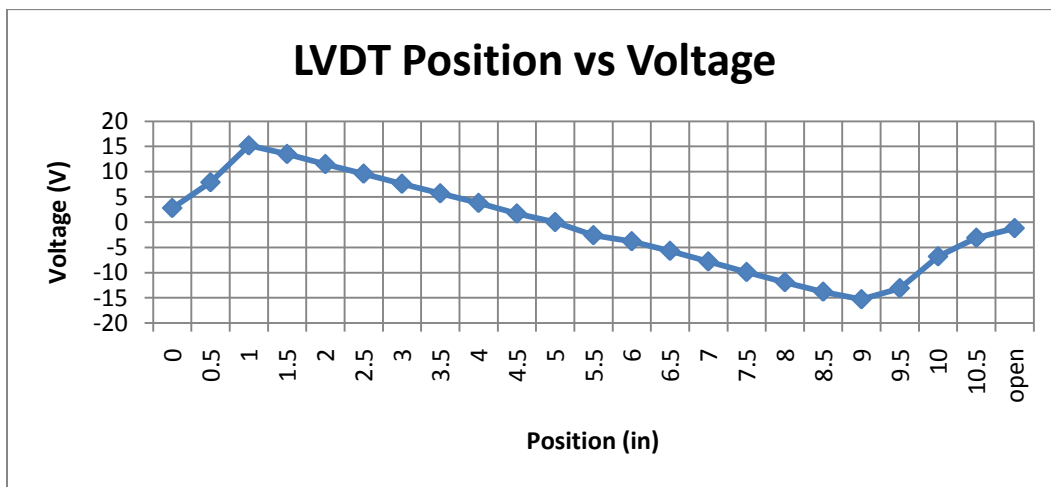

Figure 31: DC-DC LVDT Linearity Test 1

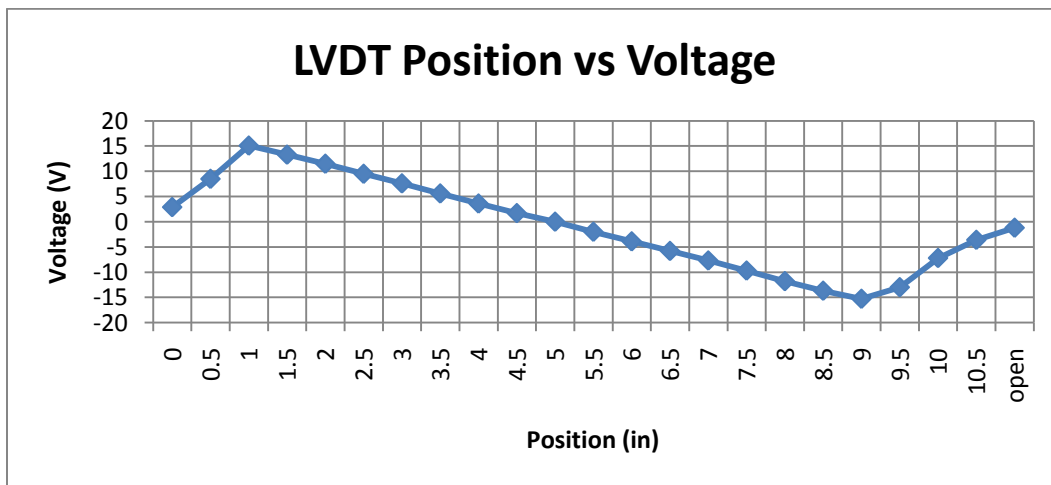

Figure 32: DC-DC LVDT Linearity Test 2

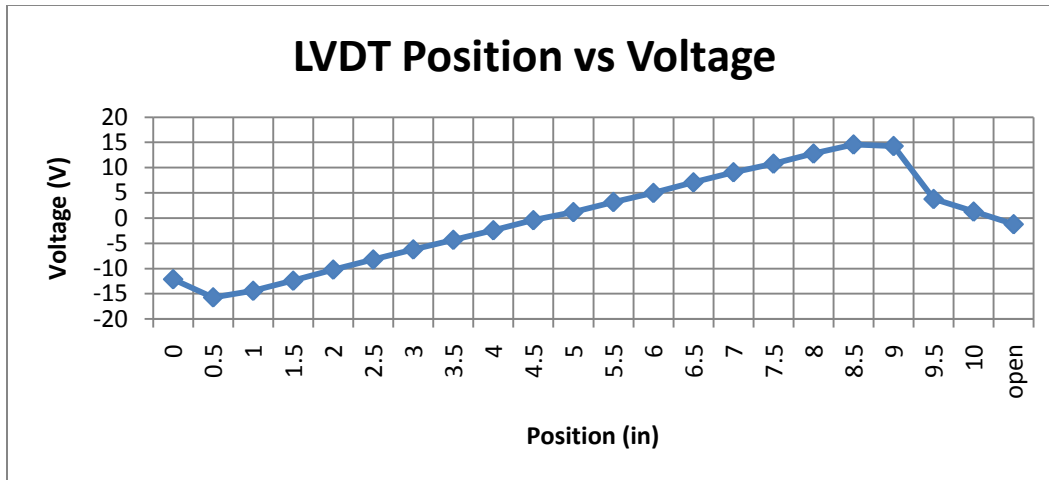
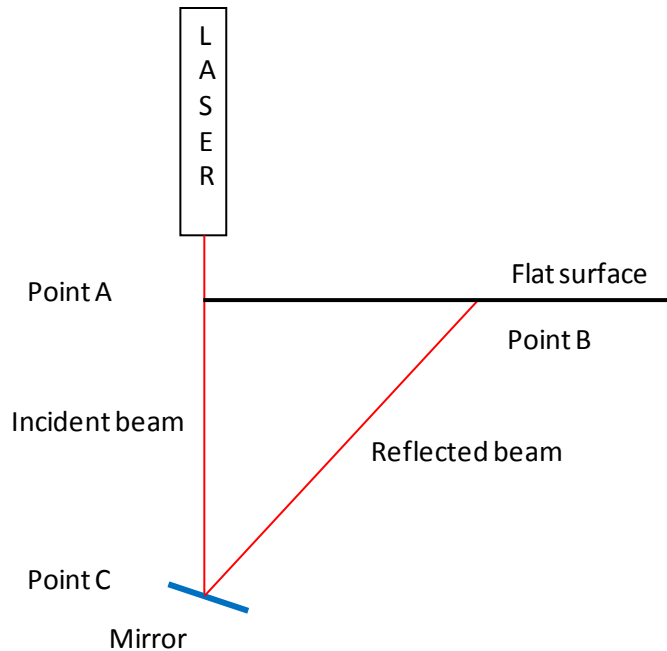

Figure 33: DC-DC LVDT Linearity Test 3

## 4.2 Hysteresis and Repeatability

A HeNe laser was mounted on an optical table. The HeNe laser was set to be normal to the side of the table and directed off the edge toward the stage. The stage was positioned in front of the optical table roughly normal to the HeNe beam. A mirror was mounted on top of the subject platform so that the mirror's center coincided with the goniometric center of rotation. The beam was reflected so that it interfered with itself. When the stage was pitched or rotated, the beam was reflected on a surface that was normal to the HeNe beam, and that was mounted at the height of the mirror. By measuring the lengths of the legs of the triangle created by the HeNe beam and the surface, the pitch or rotation angles can be calculated. Since the angle of incidence equals the angle of reflection, the measure of the mechanical angle of the stage from its central position is always one-half the measure of the angle between the incident and reflected beams. Refer to figure 34 for the following discussion.



**Figure 34: Setup for hysteresis and repeatability measurements**

Hysteresis measurements were completed for both the pitch and rotation axes. The stage was mechanically centered and rotated approximately 10 integer units on its electronic display in one direction before each measurement. In all cases of stage motion, the stage was rotated unidirectional unless it is explicitly stated that the direction was reversed. The stage was then rotated in the opposite direction until it reached its mechanical center. This was done in order to remove any backlash from the system before the measurement began. The mirror mount was then adjusted to allow the beam to interfere with itself. Throughout the measurements the distance from point A to point C was measured periodically and recorded. The electronic display was electronically zeroed before a measurement cycle. The measurement cycle began after the steps mentioned above and the stage was moved off the mechanical center in one direction, and ended when the stage was returned to this position moving in the opposite direction. The stage was rotated without reversing direction until the indicator reading was approximately an integer value. At each of the preselected stopping positions, both the indicator reading and the distance from point A to point B were recorded. After the maximum angle data had been recorded, the rotation was reversed and data were collected with the stage traveling in the opposite direction. The distance from the mirror (point C) to the plane of the measurement plane (point A) was recorded before and after each trial. The following graphs show the data from the measurements.

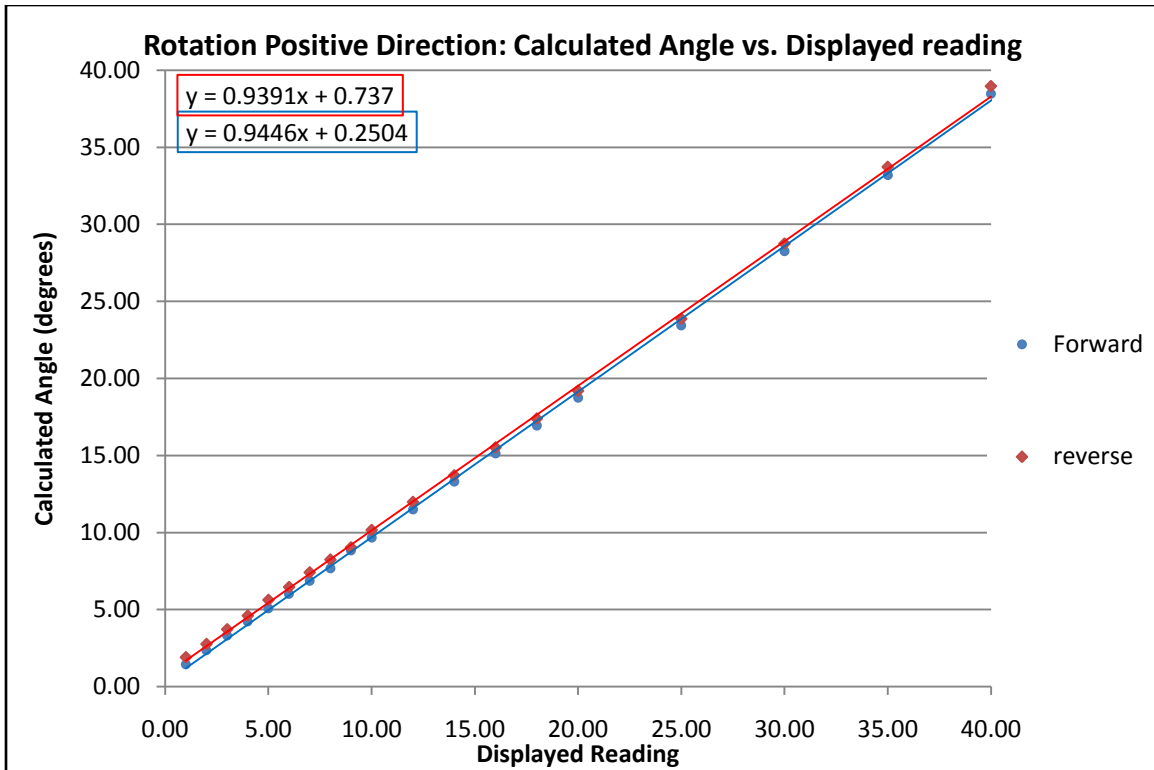

Figure 35: Rotational Axis Positive Direction Hysteresis

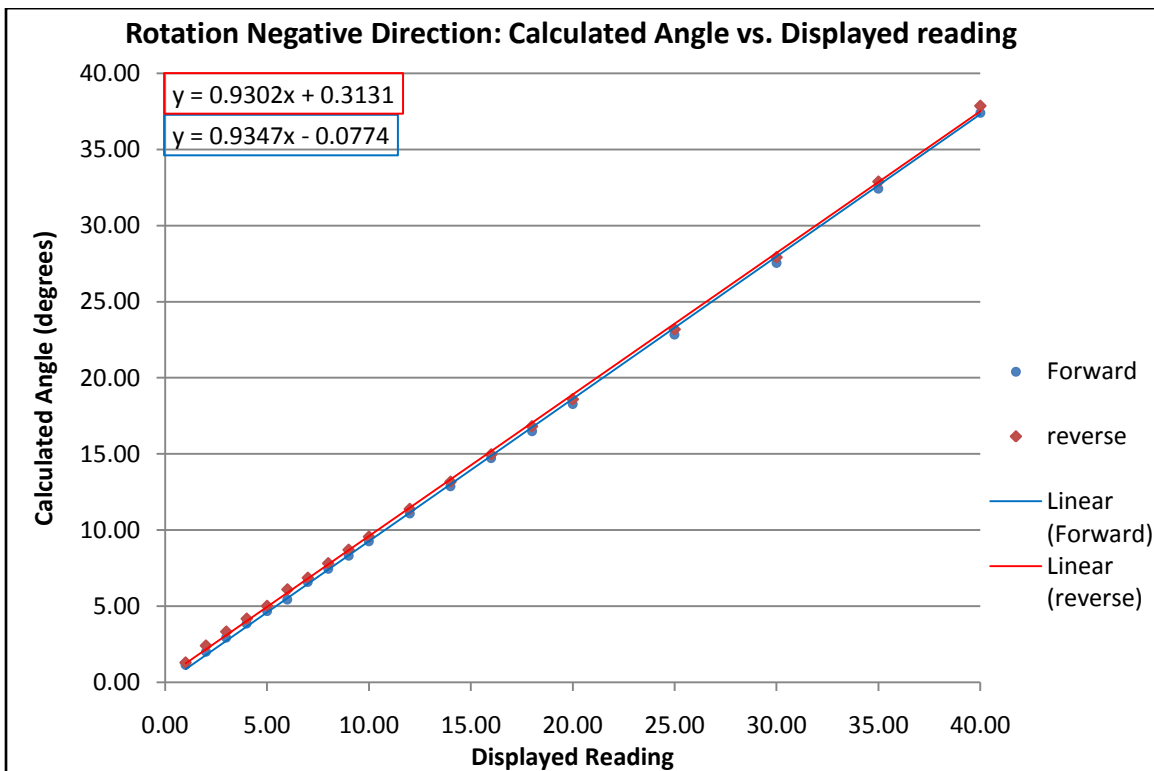
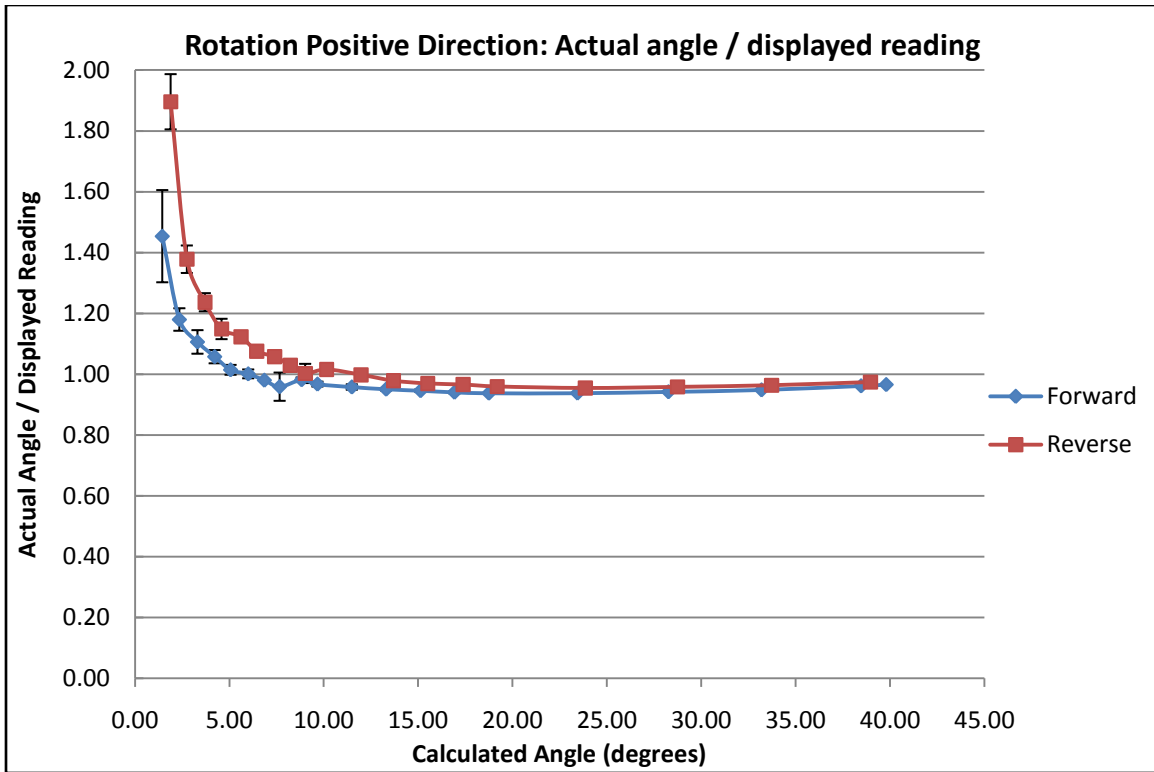
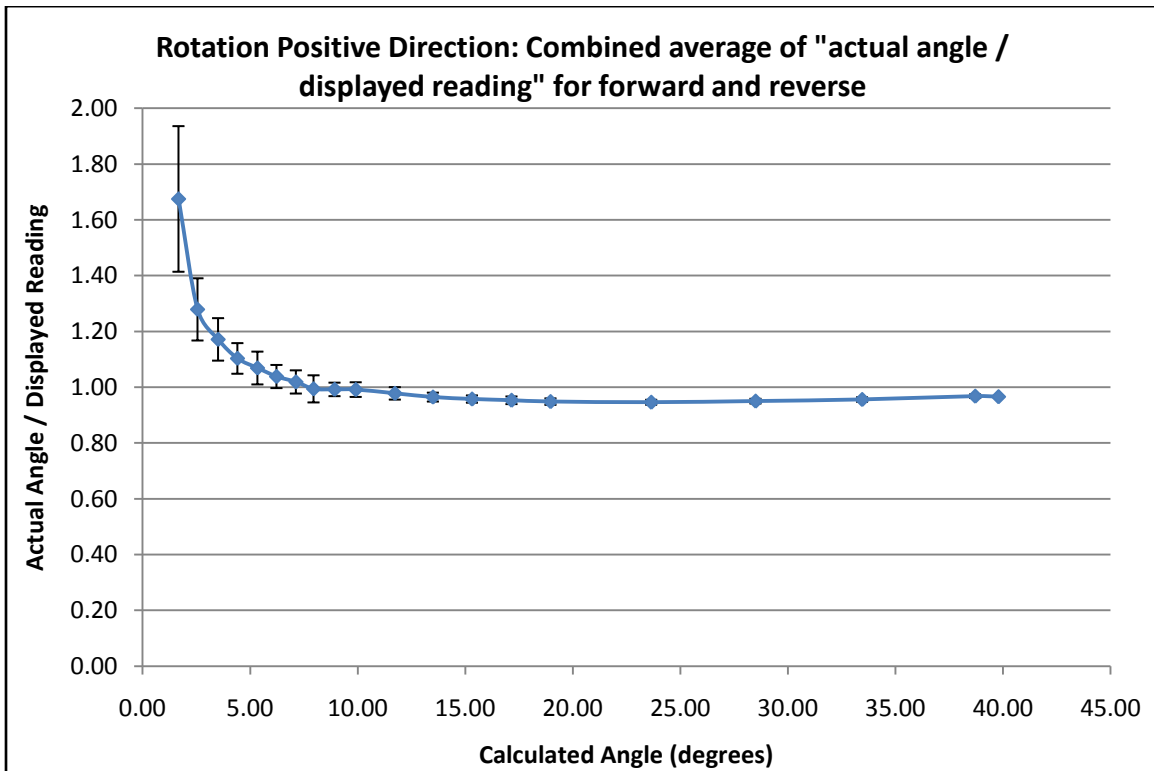

Figure 36: Rotational Axis Negative Direction Hysteresis



**Figure 37: Rotational Axis Positive Direction Repeatability**



**Figure 38: Rotational Axis Positive Direction Combined Repeatability**

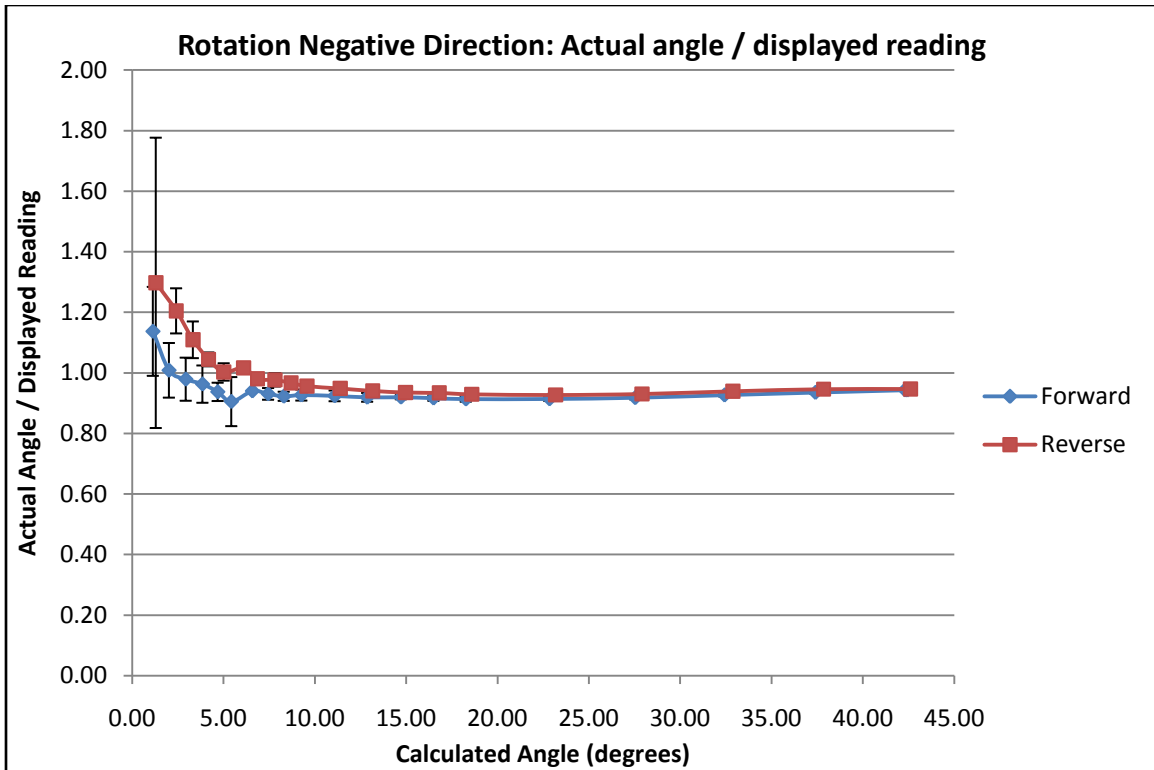

**Figure 39: Rotational Axis Negative Direction Repeatability**

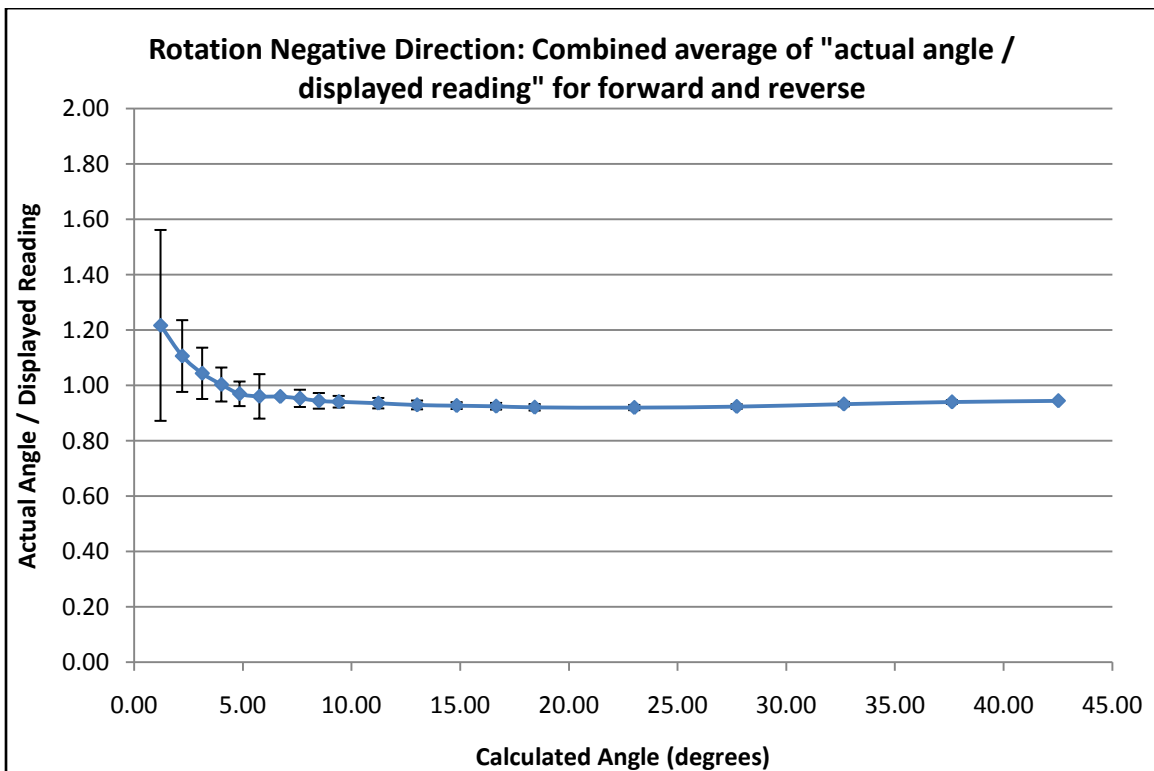

**Figure 40: Rotational Axis Negative Direction Combined Repeatability**

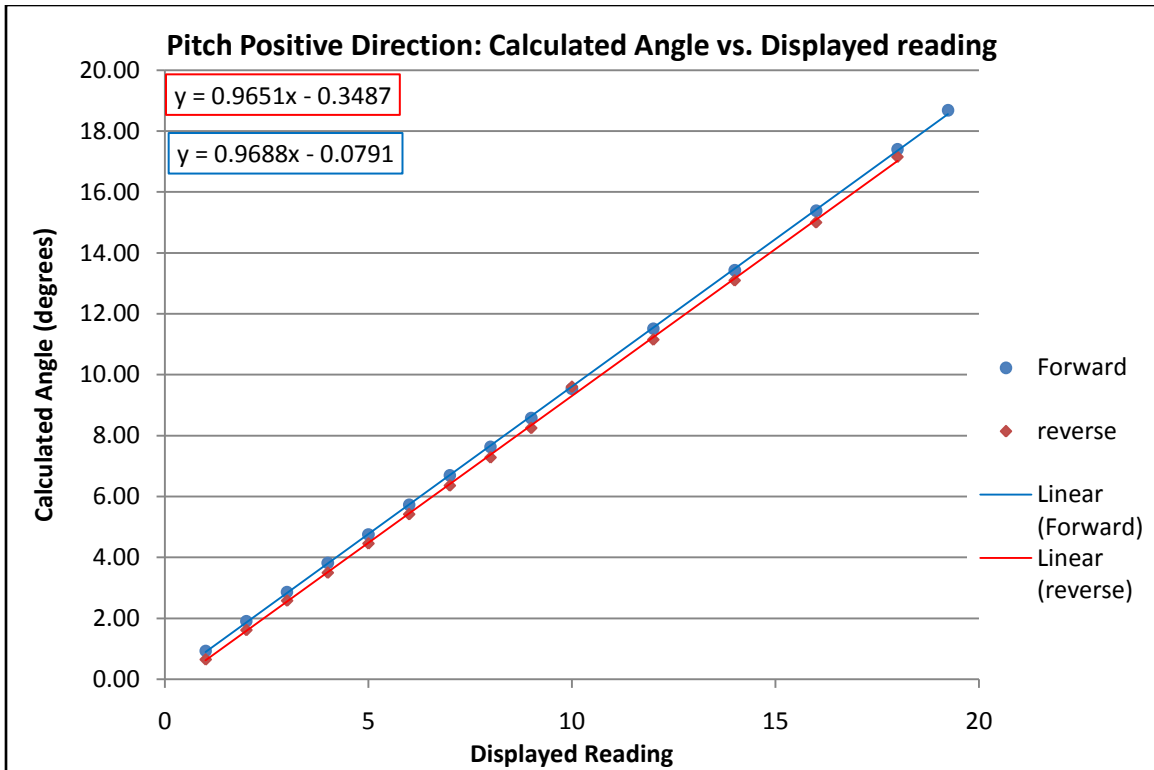

Figure 41: Pitch Axis Positive Direction Hysteresis

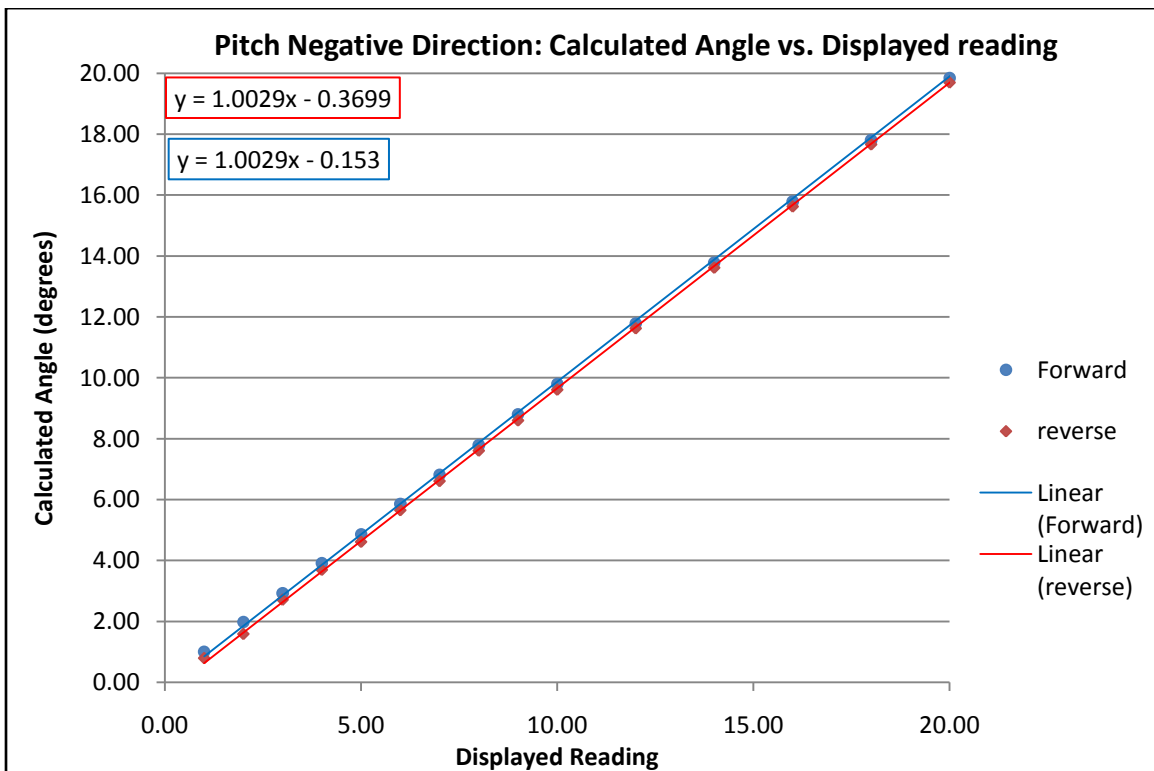

Figure 42: Pitch Axis Negative Direction Hysteresis

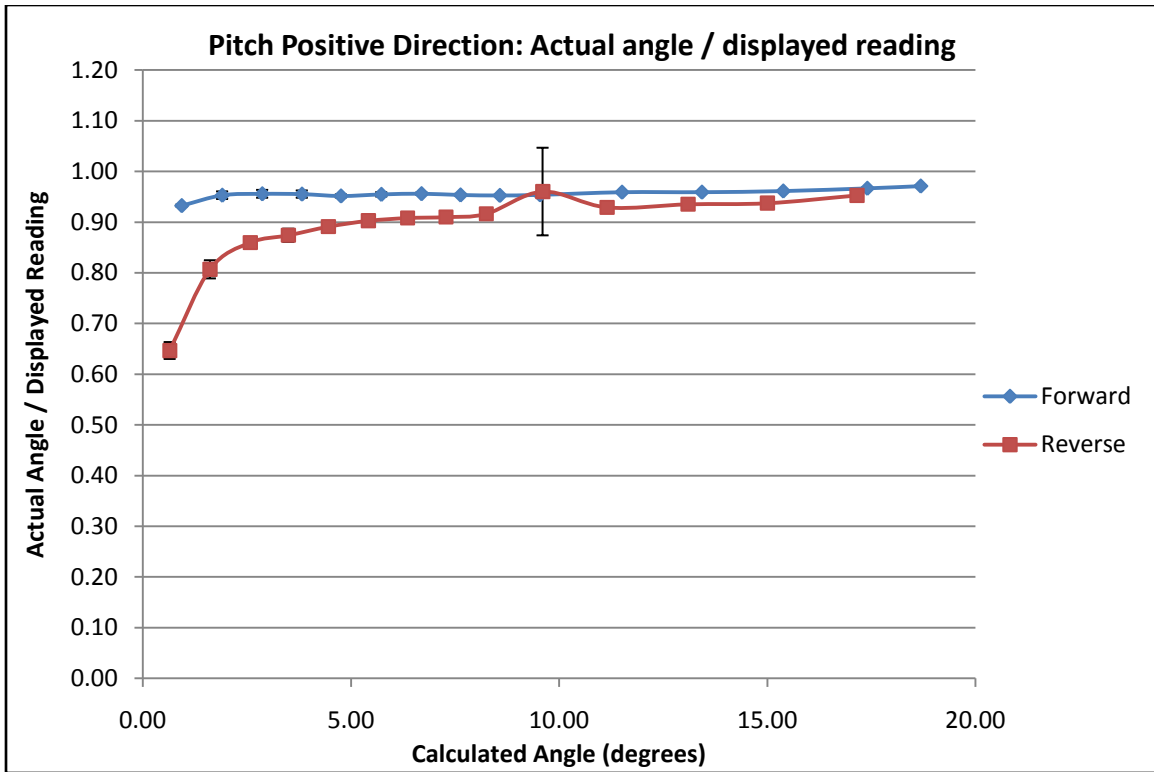

Figure 43: Pitch Axis Positive Direction Repeatability

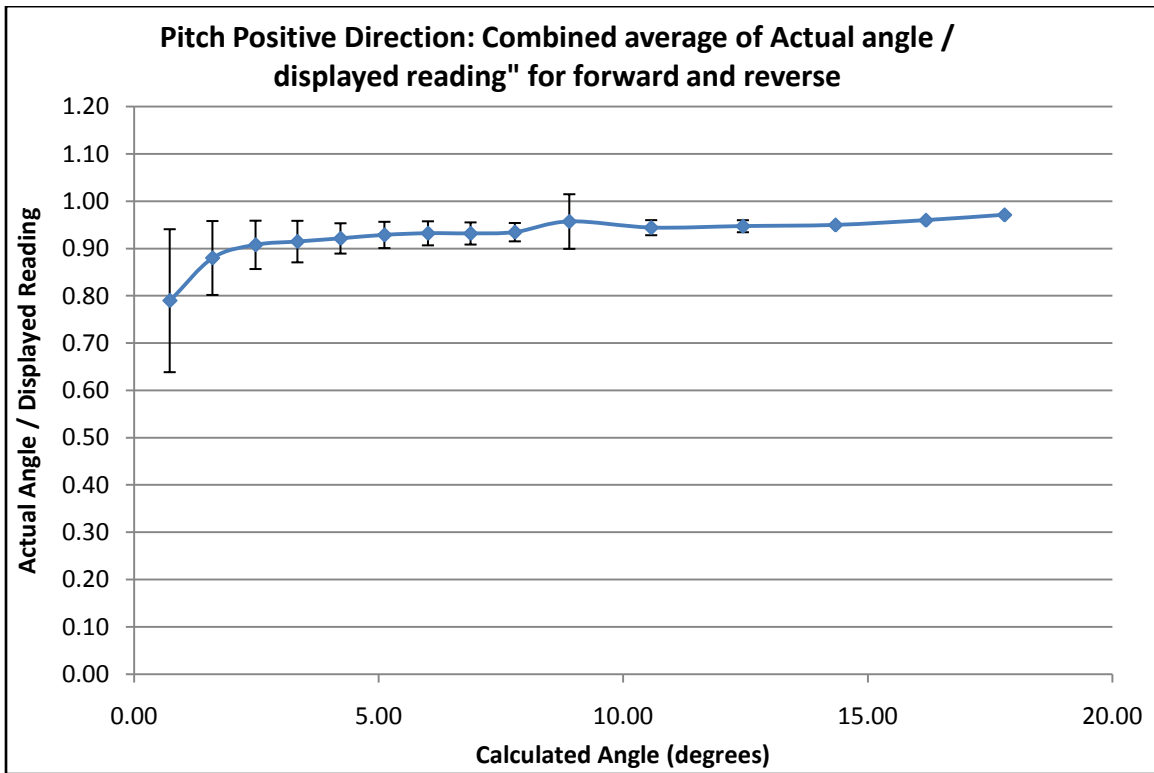
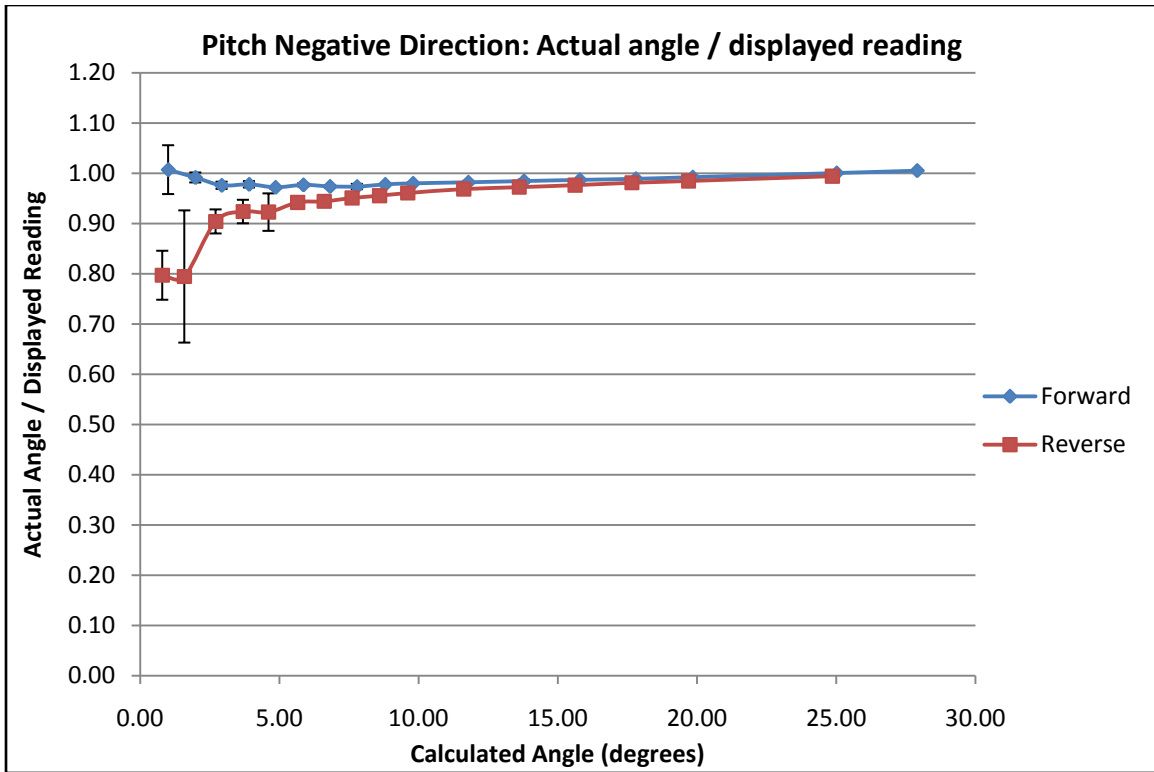
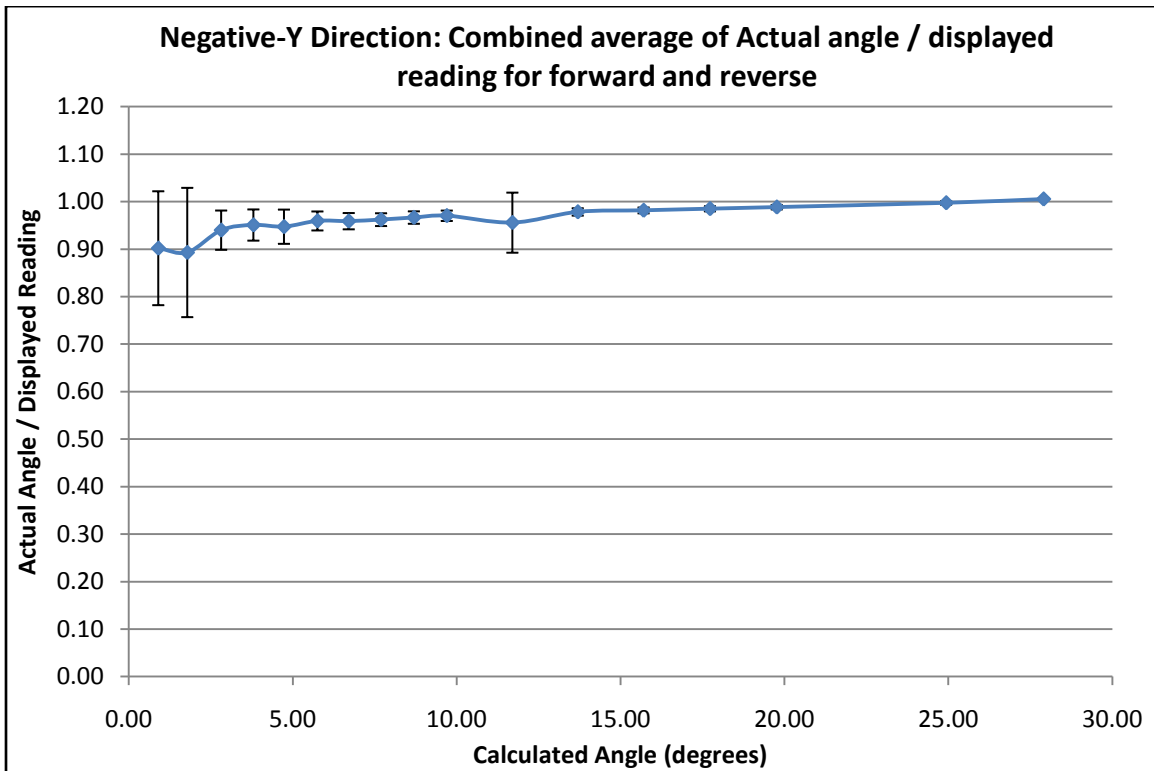

Figure 44: Pitch Axis Positive Direction Combined Repeatability



**Figure 45: Pitch Axis Negative Direction Repeatability**



**Figure 46: Pitch Axis Negative Direction Combined Repeatability**

## 5 MAINTENANCE

Clean the stage between experiments. Do not allow fluids to build-up on surfaces during experiments. Ensure that all the saline is removed after each use. If corrosion is present, remove it and lubricate the system appropriately.

Monthly maintenance during regular usage:

- Perform a visual inspection, and clean the stage as necessary.
- Check that screw jack is lubricated. Lubricate with No.1 consistency grease as necessary. Grease through the fitting on the jack.
- Lubricate XSlide with Velmex BL-1 oil. After moving the carriage to the center of motion, add 2-3 drops to the carriage ends on the lead screw threads and way surfaces
- Lubricate XY stack leadscrew threads with Velmex BL-1 oil.

**Table 4: Recommended products for screw jack lubrication**

<i>Company</i>	<i>Brand Name</i>
Mobilgrease	XHP 461
Shell Oil Company	Retinax HD NLGI 1
Shell Oil Company	Albina SLC 460
Mobil Oil	Mobilith SHC PM 460

Total grease capacity for screw jack

Shots: 3

Weight: 1.0 oz

## 6 GLOSSARY

**Acme thread** – are the most common forms used for lead-screws. They are typically found where large loads or high accuracy are required, as in a thread type used for mechanical motion.

**Caster** – is an un-driven wheel that is designed to be mounted to the bottom of a larger object so as to enable that object to be easily moved.

**Dovetail slide** – A type of linear slide with a v-shaped carriage.

**Drive nut** – a nut driven by a lead-screw.

**Goniometric stage** – A device used to rotate an object precisely about a fixed off-axis point in space.

**Limit switches** – A switch that breaks an electric circuit when a mechanical limit is reached.

**Linear bearing** – A bearing that is design to slide to provide free motion in one dimension instead of rotate.

**Linear stage** – A device made of a platform and a base with only one degree of freedom.

**LVDT (Linear Variable Differential Transformer)** – is a type of electrical transformer used for measuring linear displacement.

**Pillow-block** – a housing that mounts a bearing to a flat surface.

**Planetary gear reducer** - is a reducing gear system that consists of one or more outer gears, or planet gears, revolving about a central, or sun gear.

**Potentiometer** – variable resistor.

**Screw-jack-actuator** – an actuator that uses a lead-screw mechanism to create the motion.

**Telescopic pillar** – a column that can be lengthened by sliding an internal column.

**Worm gear** – gear consisting of a shaft with screw thread (the worm) that drives a toothed wheel (the worm wheel) which changes the direction of the axis of rotary motion.

**This Page Intentionally left Blank**

## 7 Appendix A: Electrical Drawings

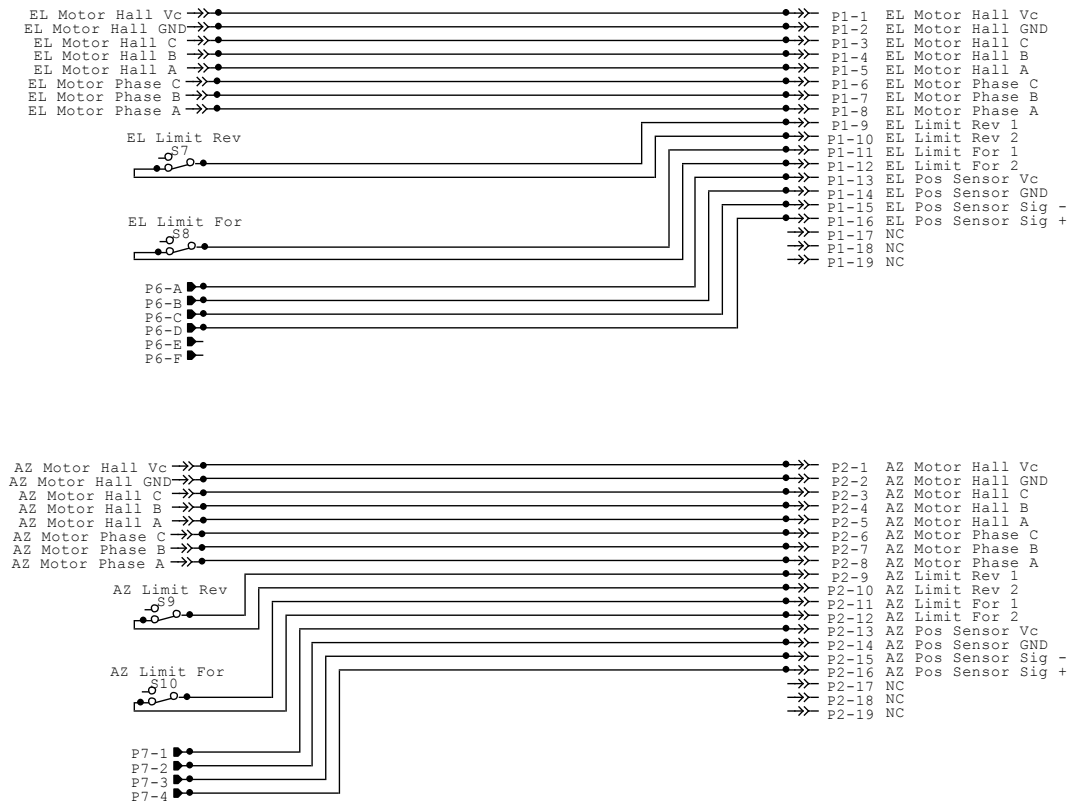
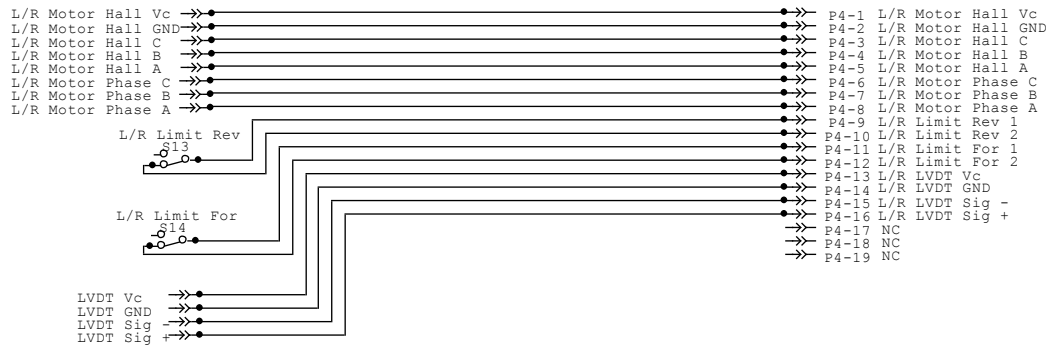
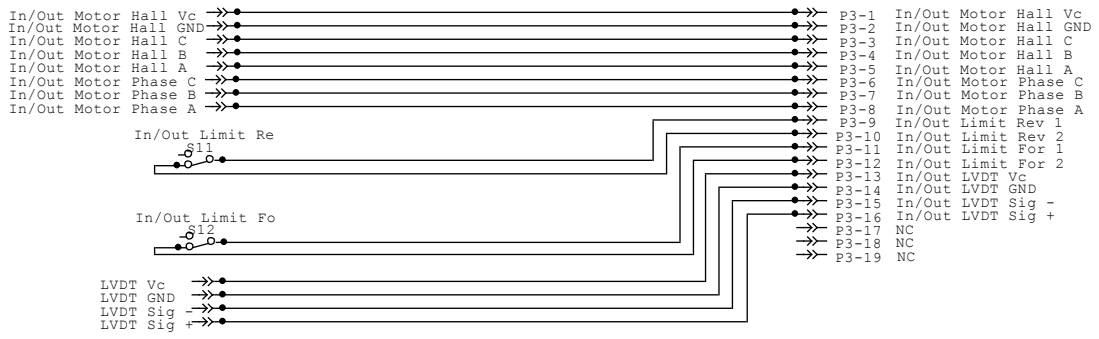

Figure 47: Pitch and rotation wiring



**Figure 48: In/Out and Left/Right wiring**

# 8 Appendix B: Mechanical Drawings

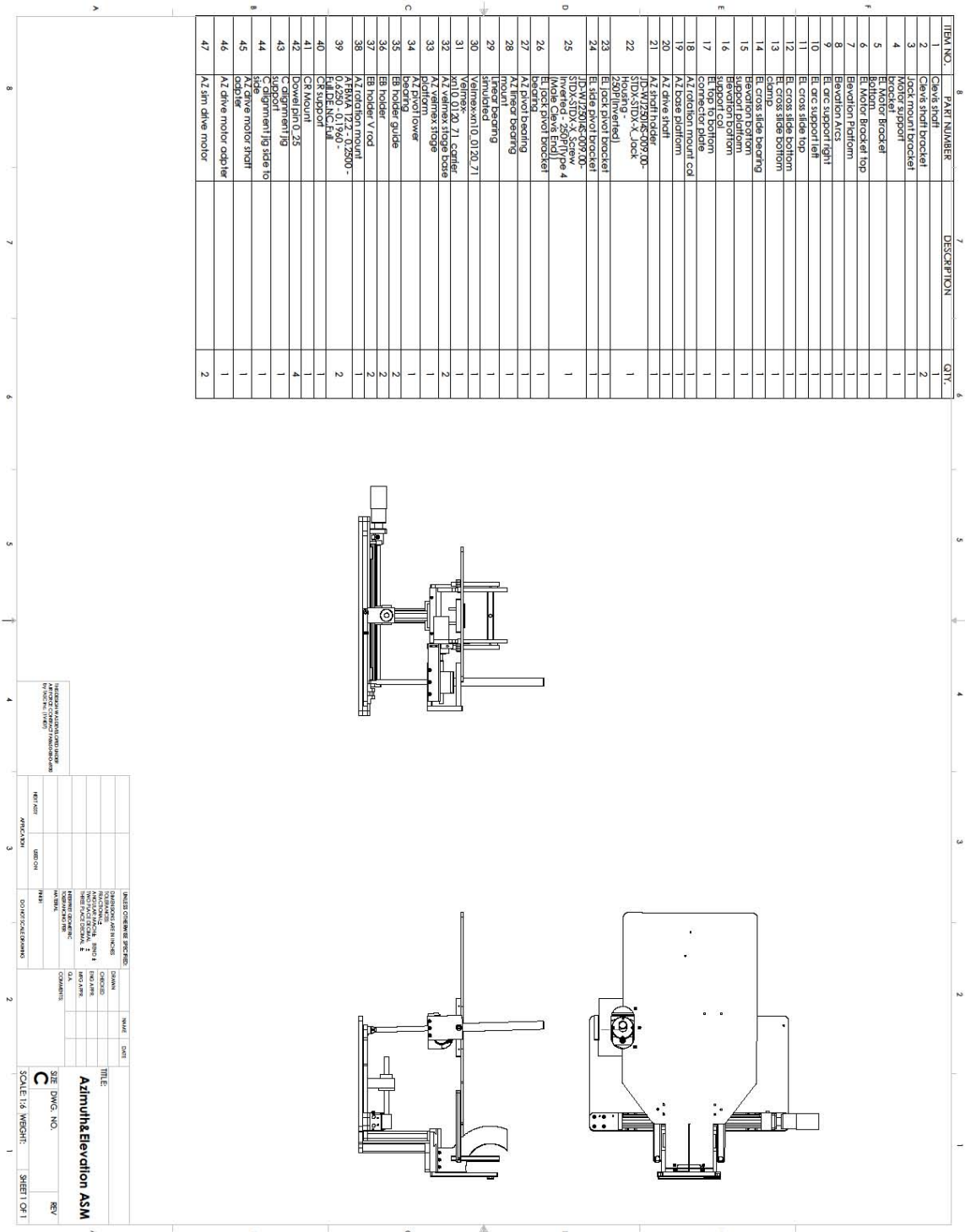

Figure 49: Goniometric Section

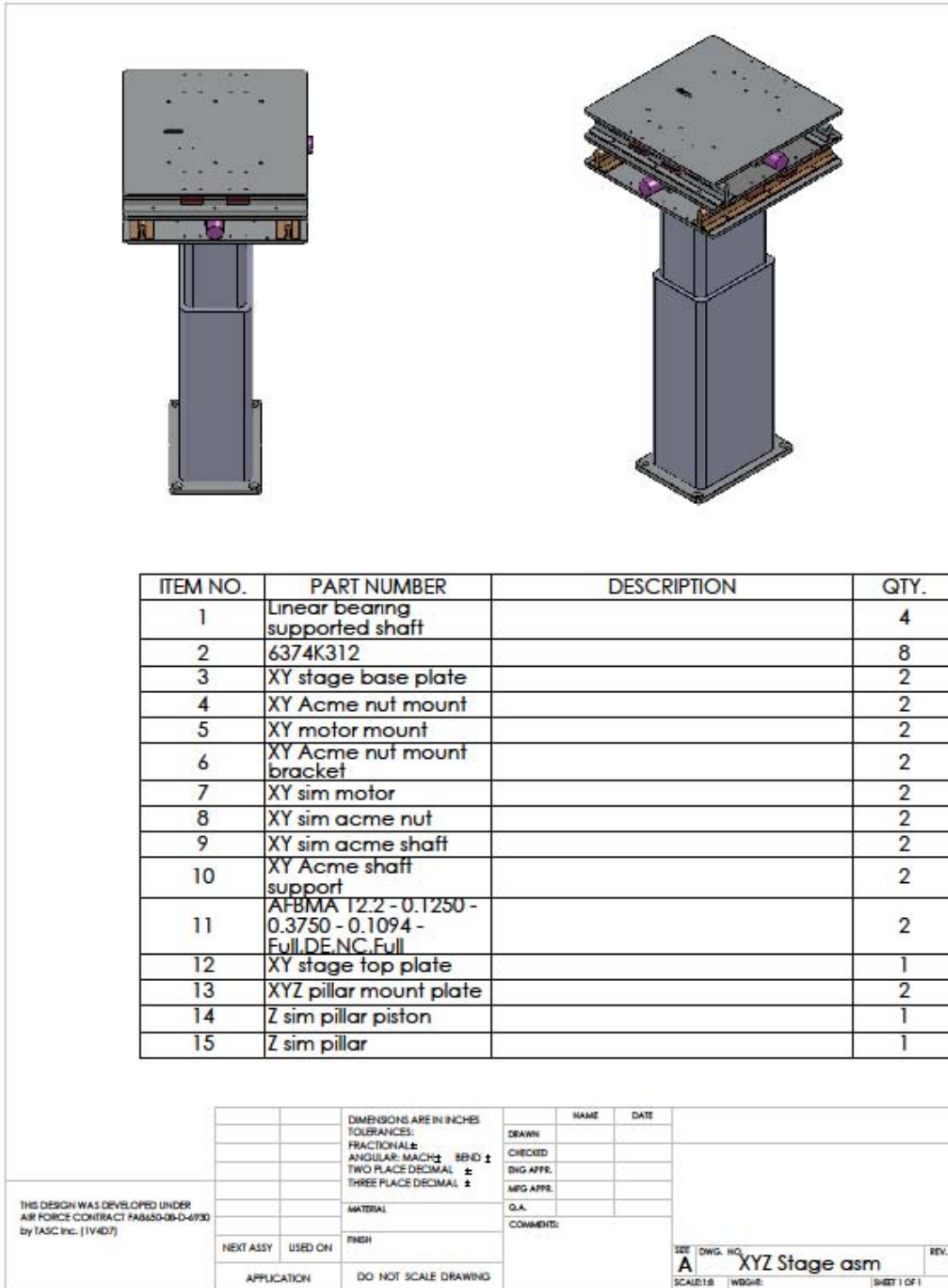

Figure 50: XYZ Section

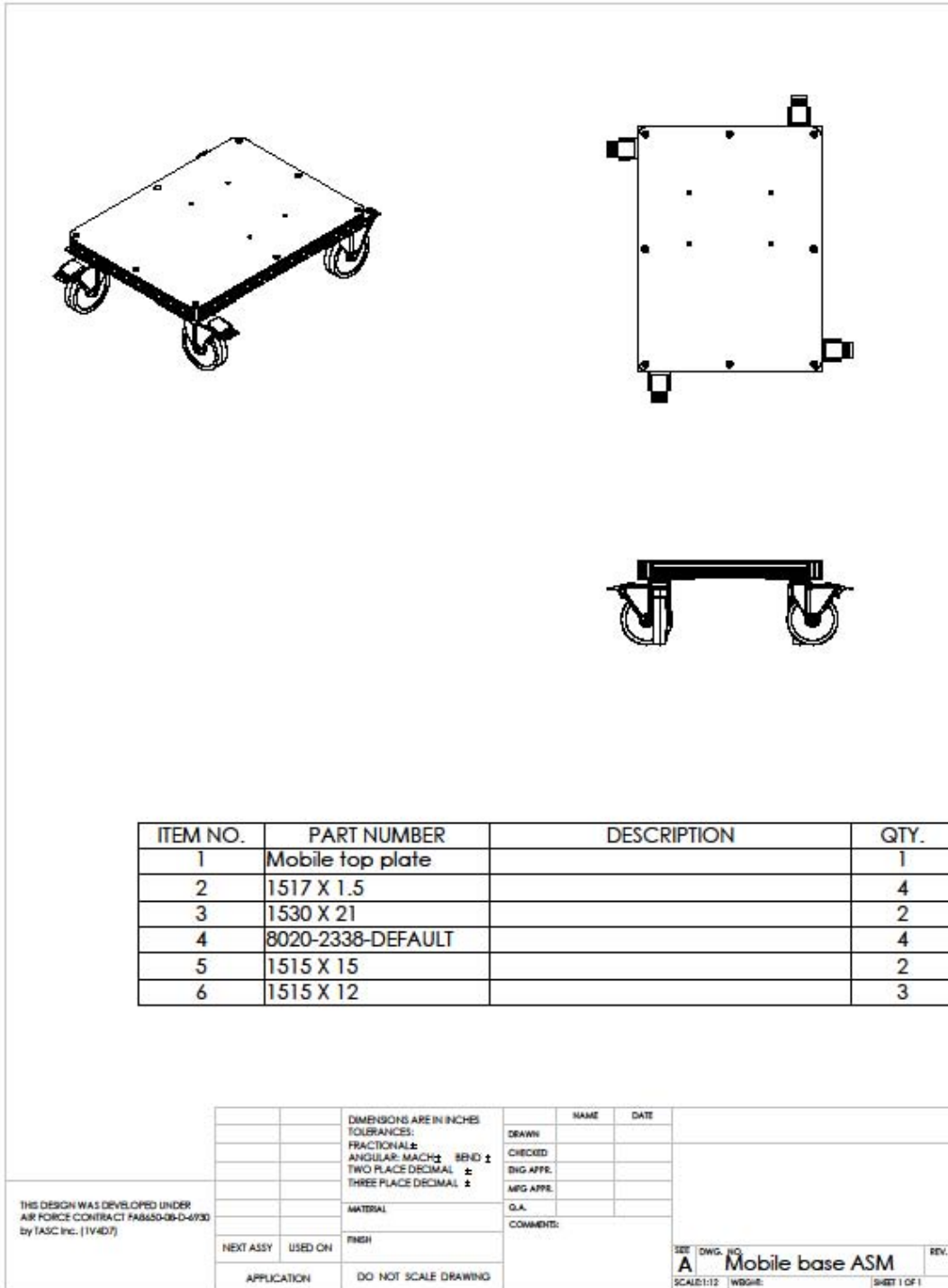

Figure 51: Mobile Base Section



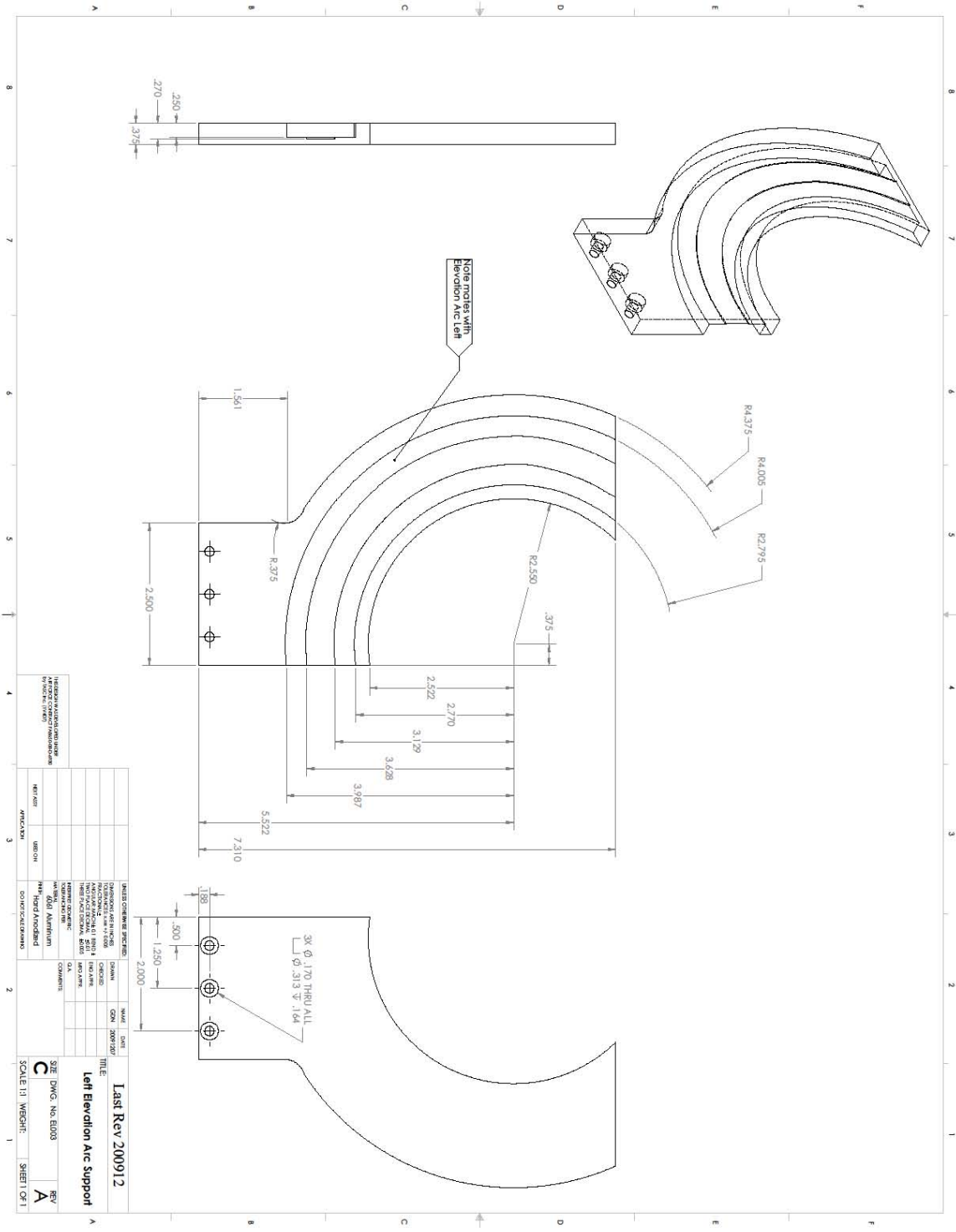

Figure 53: Elevation Left Arc Support







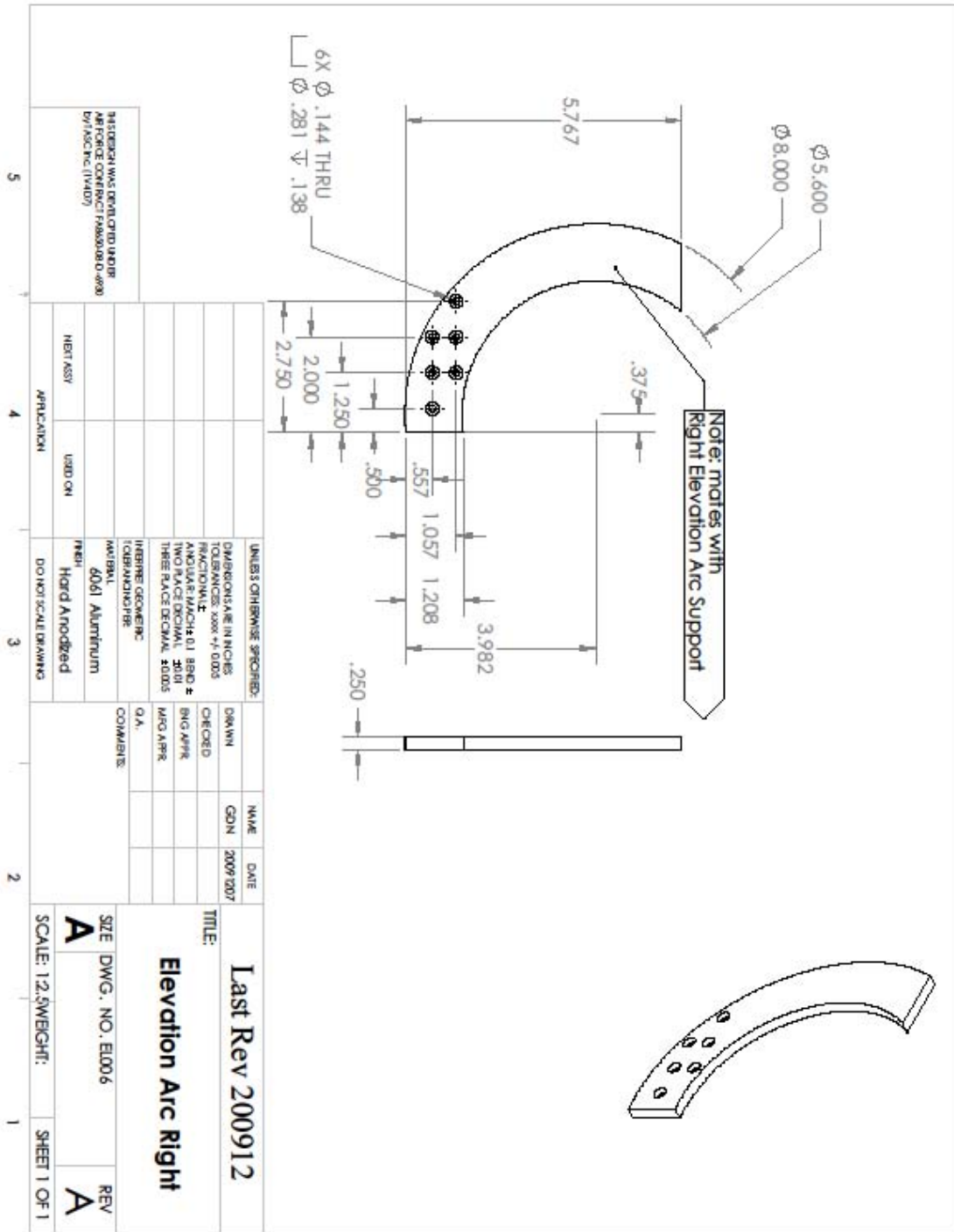

Figure 57: Elevation Arc Right



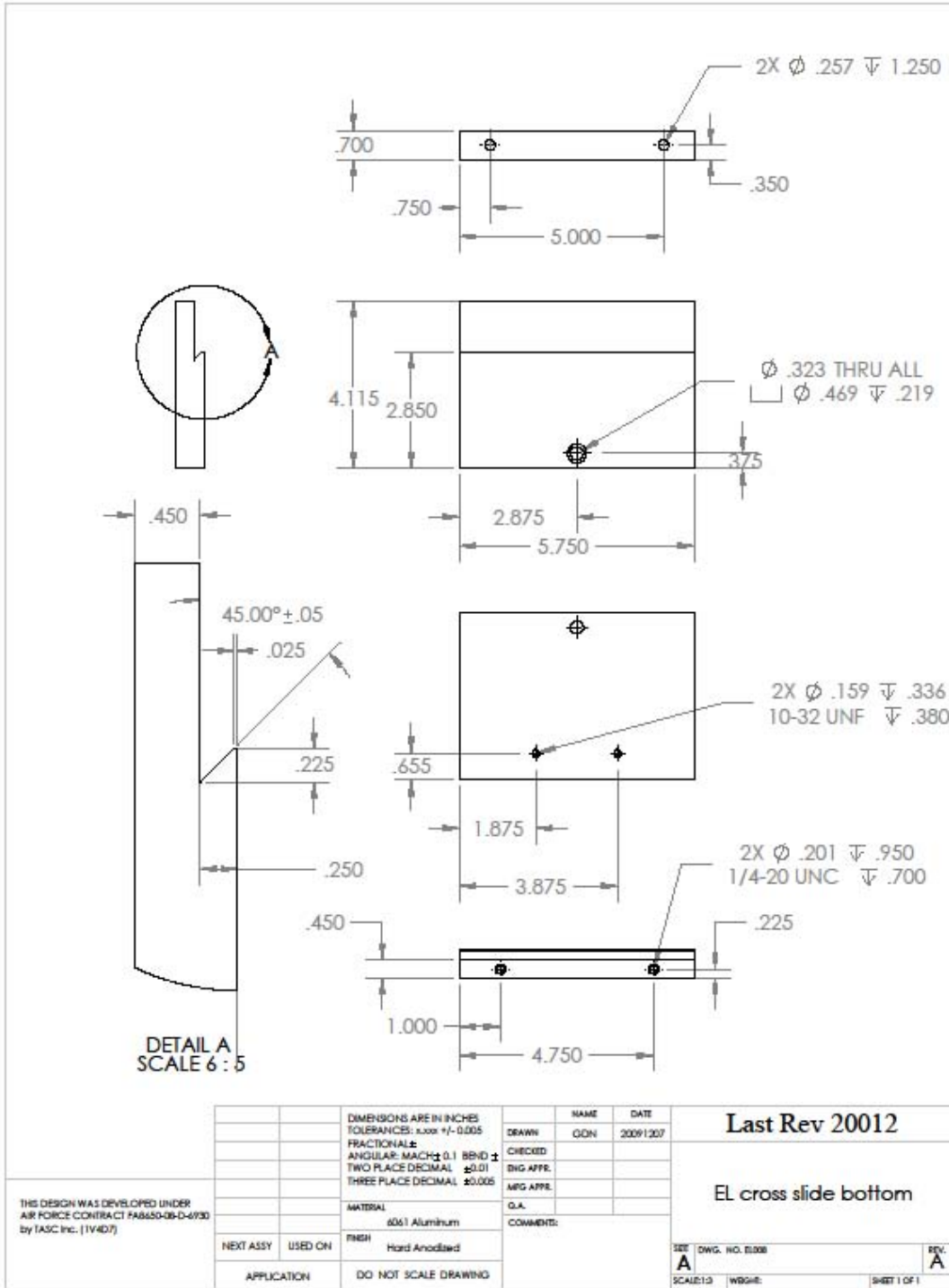

Figure 59: Elevation Cross Slide Bottom

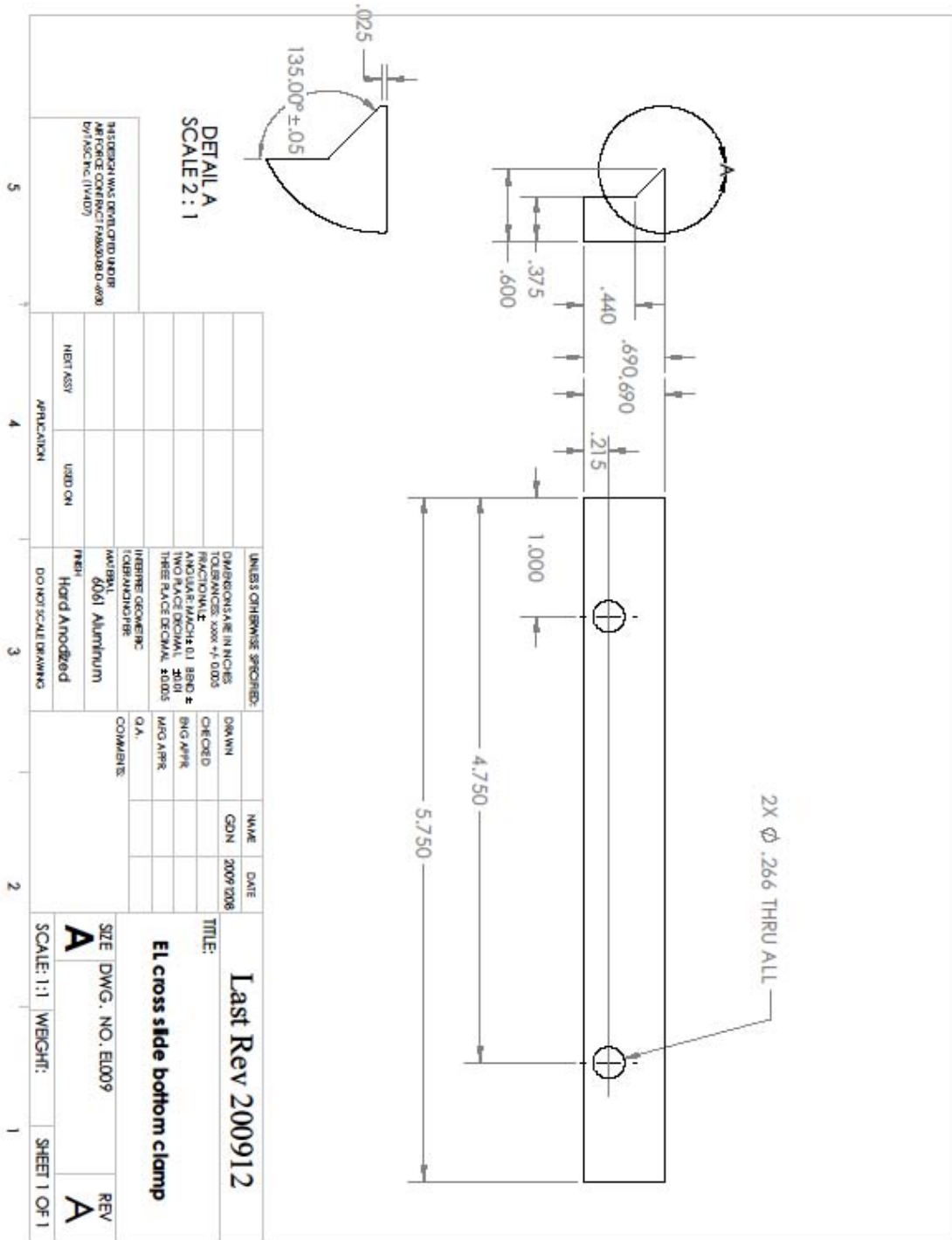

Figure 60: Elevation Cross Slide Clamp

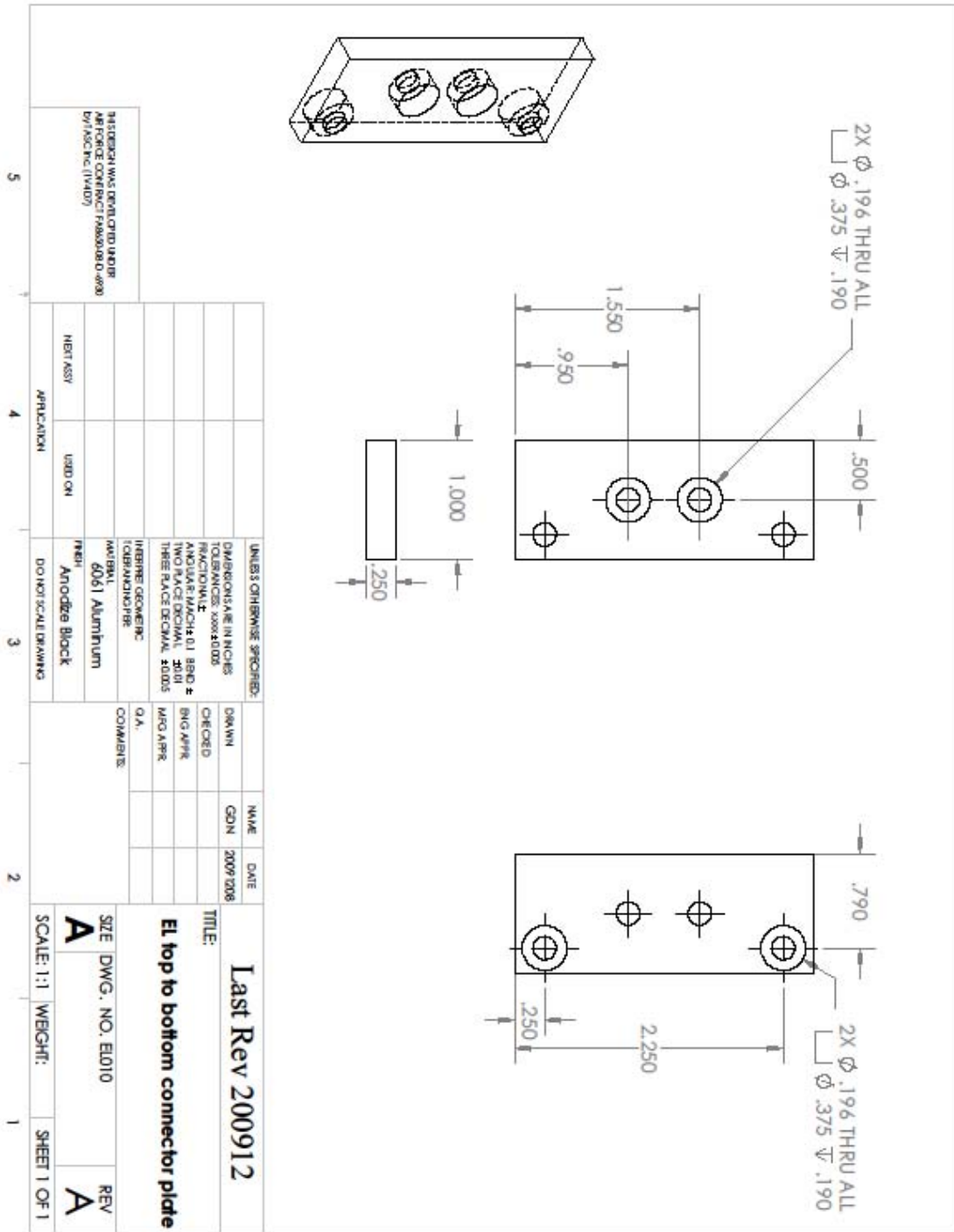

Figure 61: Elevation Top to Bottom Connector Plate

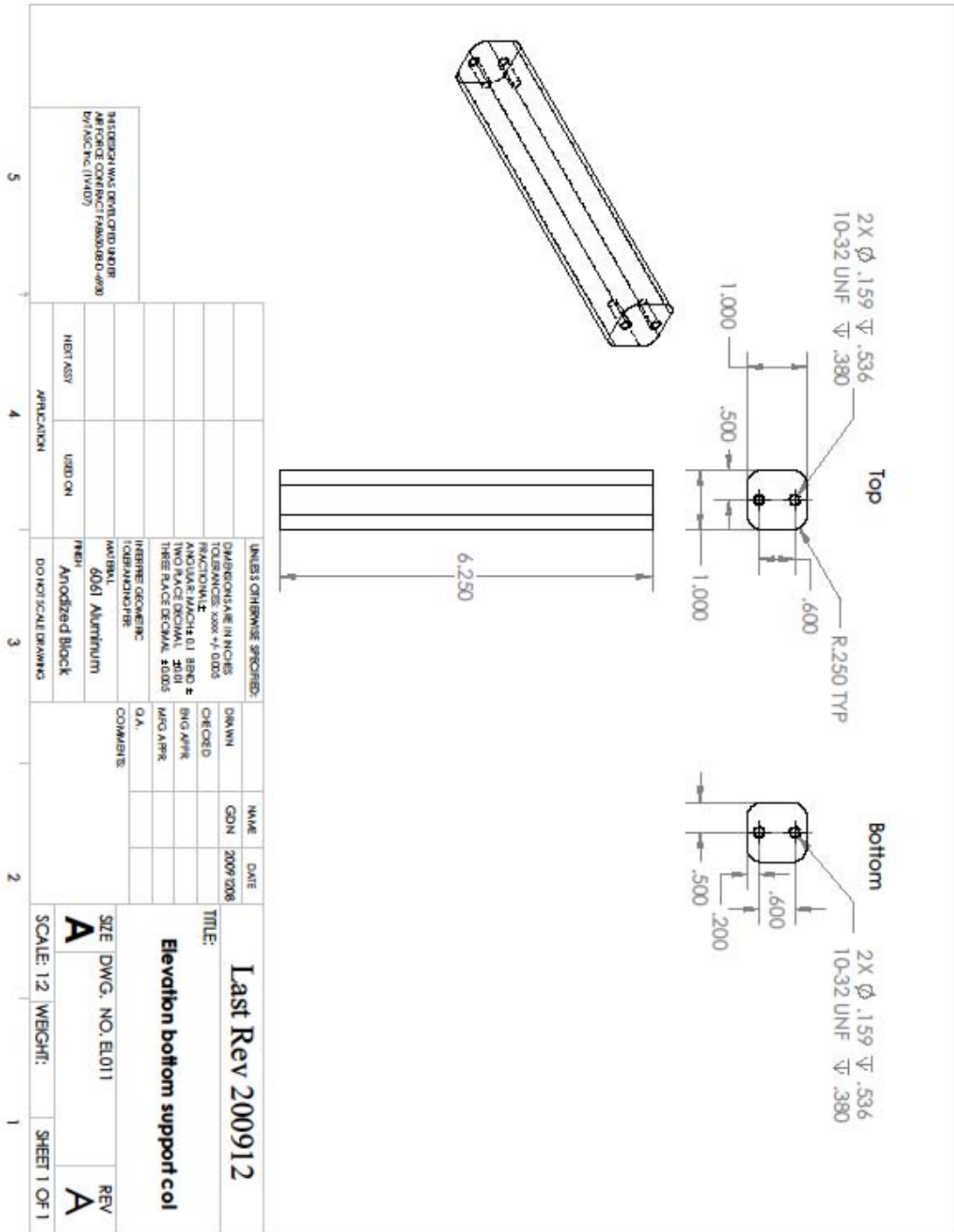

Figure 62: Elevation Bottom Support Column

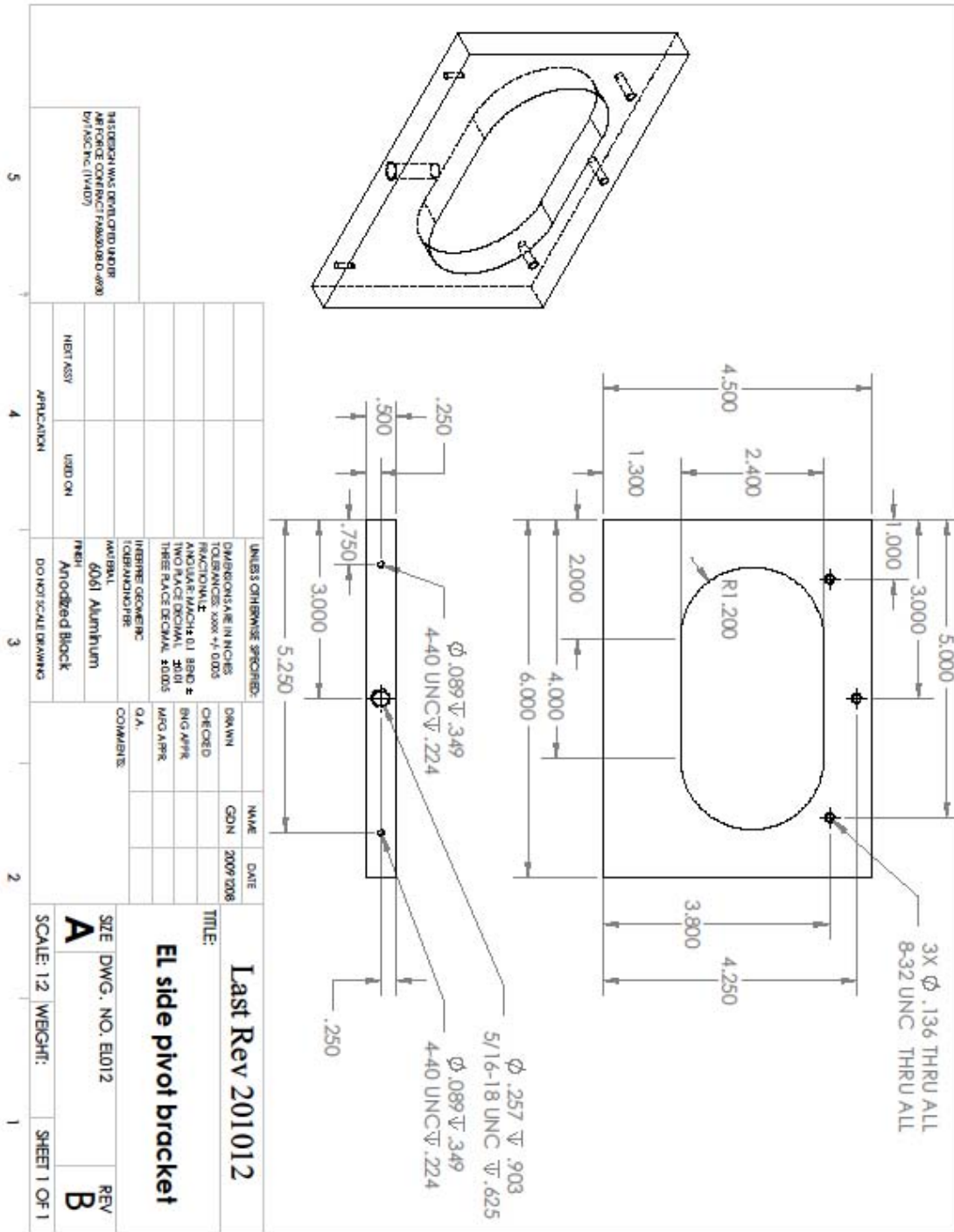

Figure 63: Elevation Side Pivot Bracket

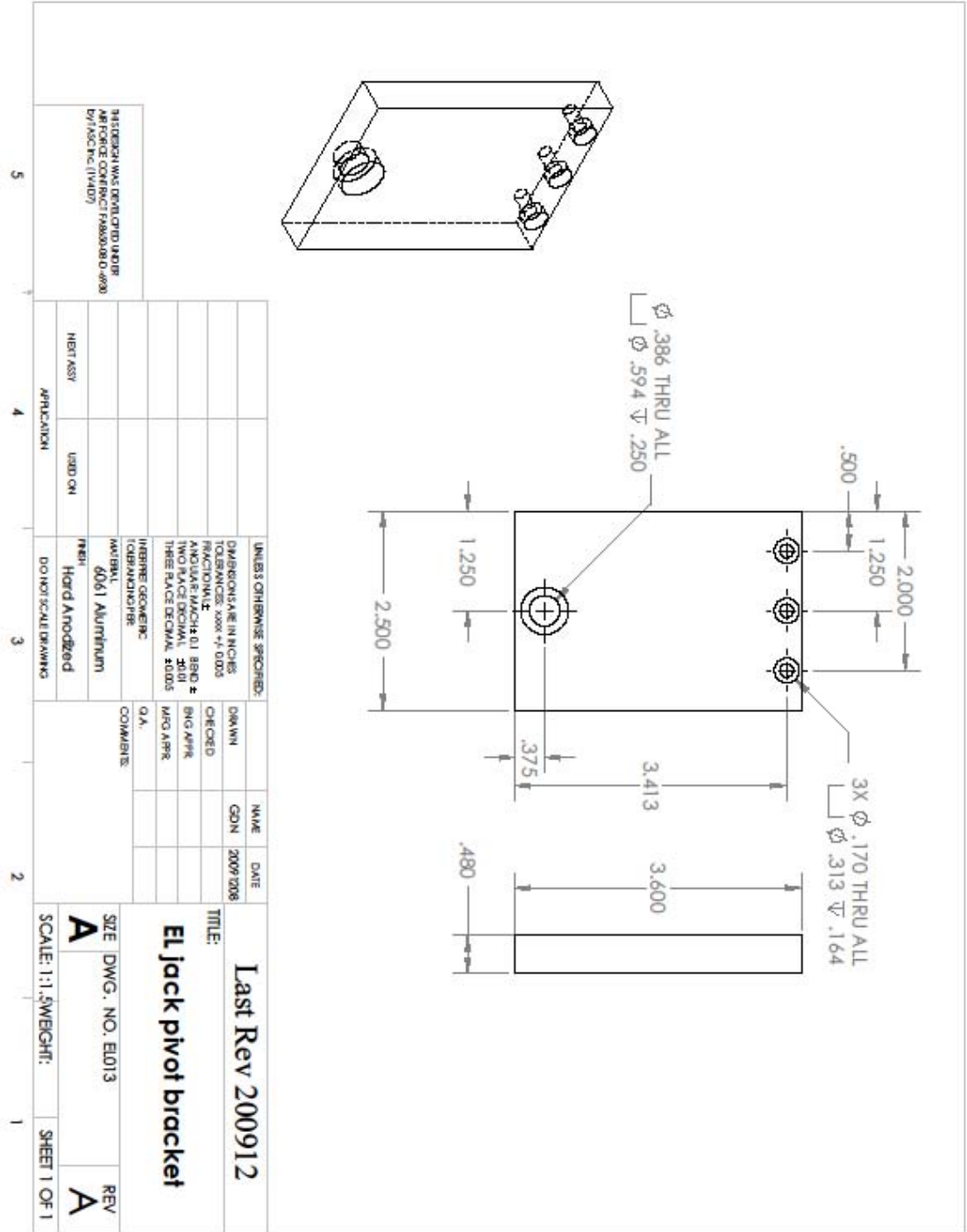

Figure 64: Elevation Jack Pivot Bracket

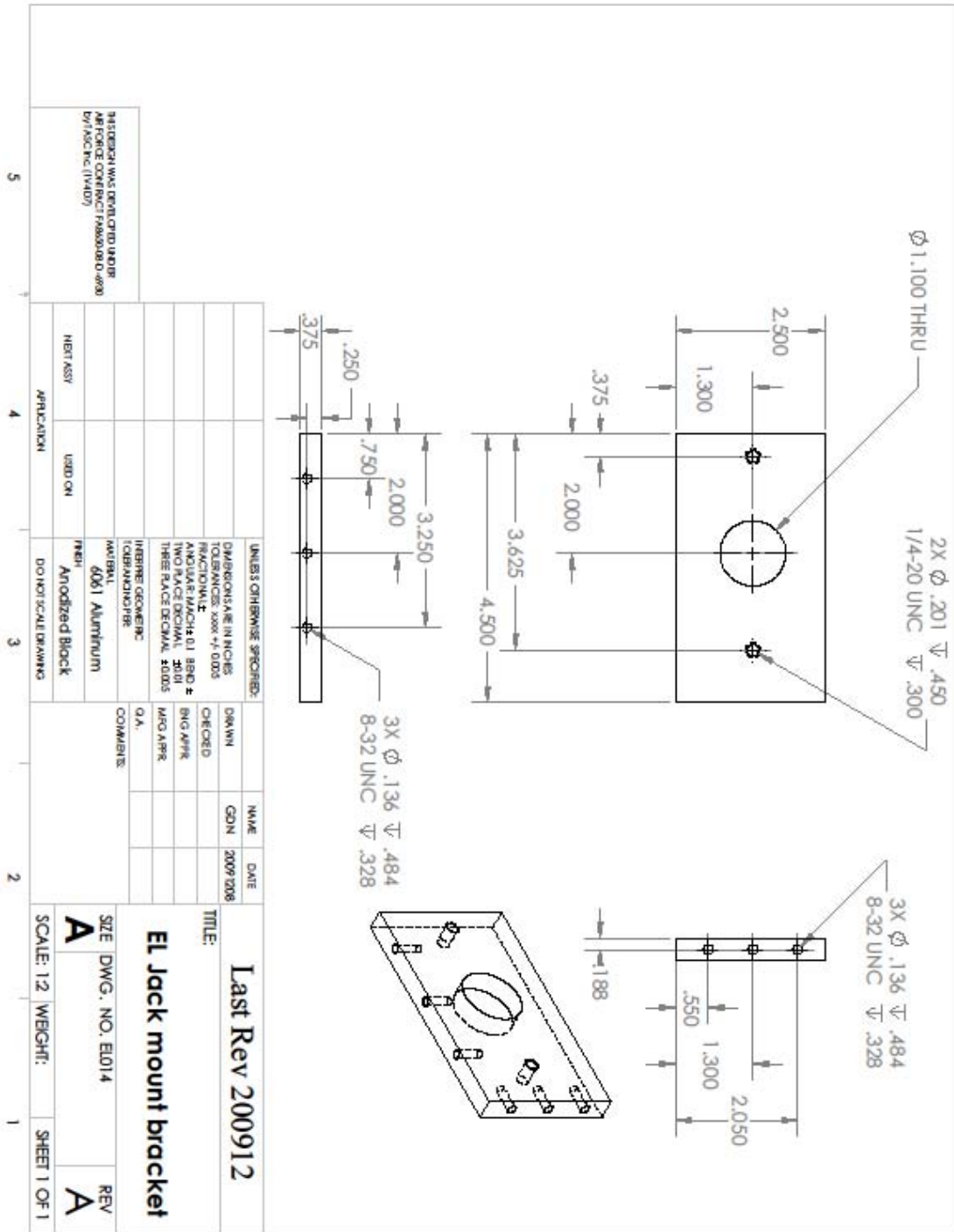
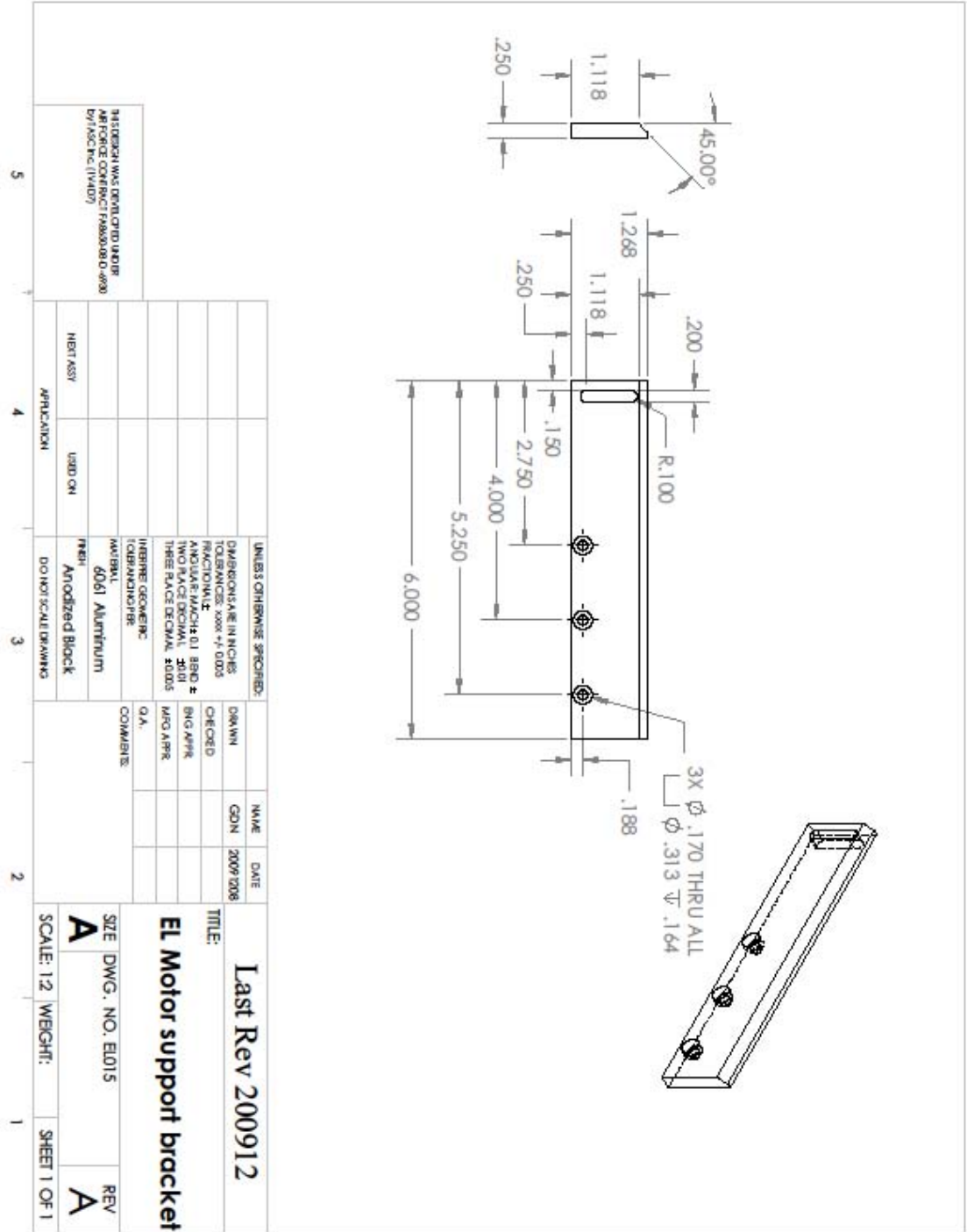

Figure 65: Elevation Jack Mount Bracket



UNLESS OTHERWISE SPECIFIED:		NAME	DATE
DIMENSIONS ARE IN INCHES		GDN	2009/2008
TOLERANCES: XXX ±.0005		DRAWN	
FRACTIONS: 1/16		CHECKED	
ANGLES: CHG. 0.1 DEG. ±		ENG APPR	
TWO PLACE DECIMAL: .0010		MFG APPR	
THREE PLACE DECIMAL: .0005		Q.A.	
INTERNAL GEOMETRIC TOLERANCES PER ASME Y14.5		COMMENTS:	
MATERIAL: 6061 Aluminum		FINISH: Anodized Black	
DO NOT SCALE DRAWING		HEAT ASSY: USED ON	
APPLICATION		REVISIONS:	
5		4	

THE DESIGN WAS DEVELOPED UNDER AIR FORCE CONTRACT F49620-01-0-0003 BY INSCITE (114107)

**EL Motor support bracket**

TITLE: **Last Rev 200912**

SIZE: DWG. NO. ELD15

SCALE: 1:2 WEIGHT: REV **A**

SHEET 1 OF 1

Figure 66: Elevation Motor Support Bracket

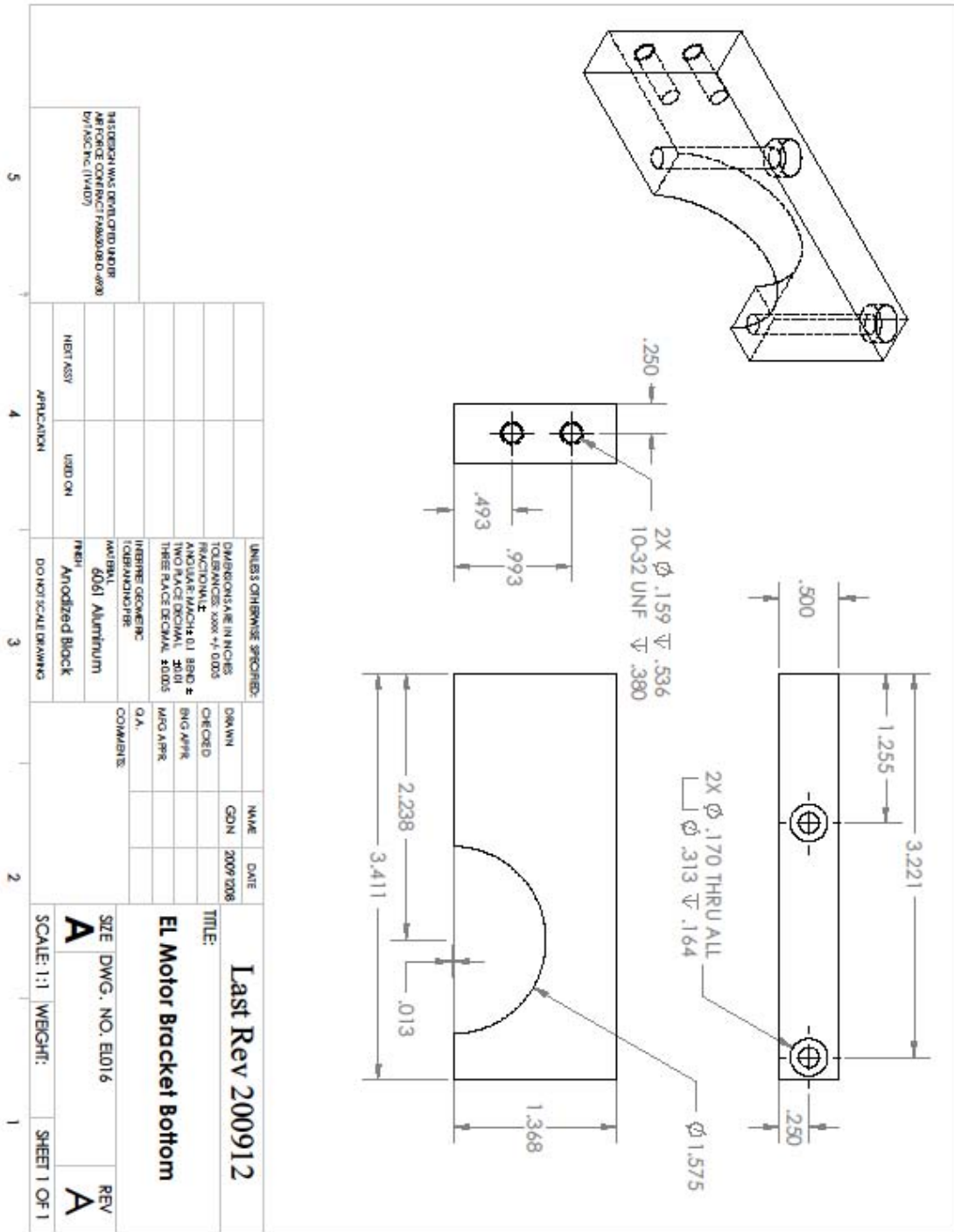

Figure 67: Elevation Motor Bracket Bottom

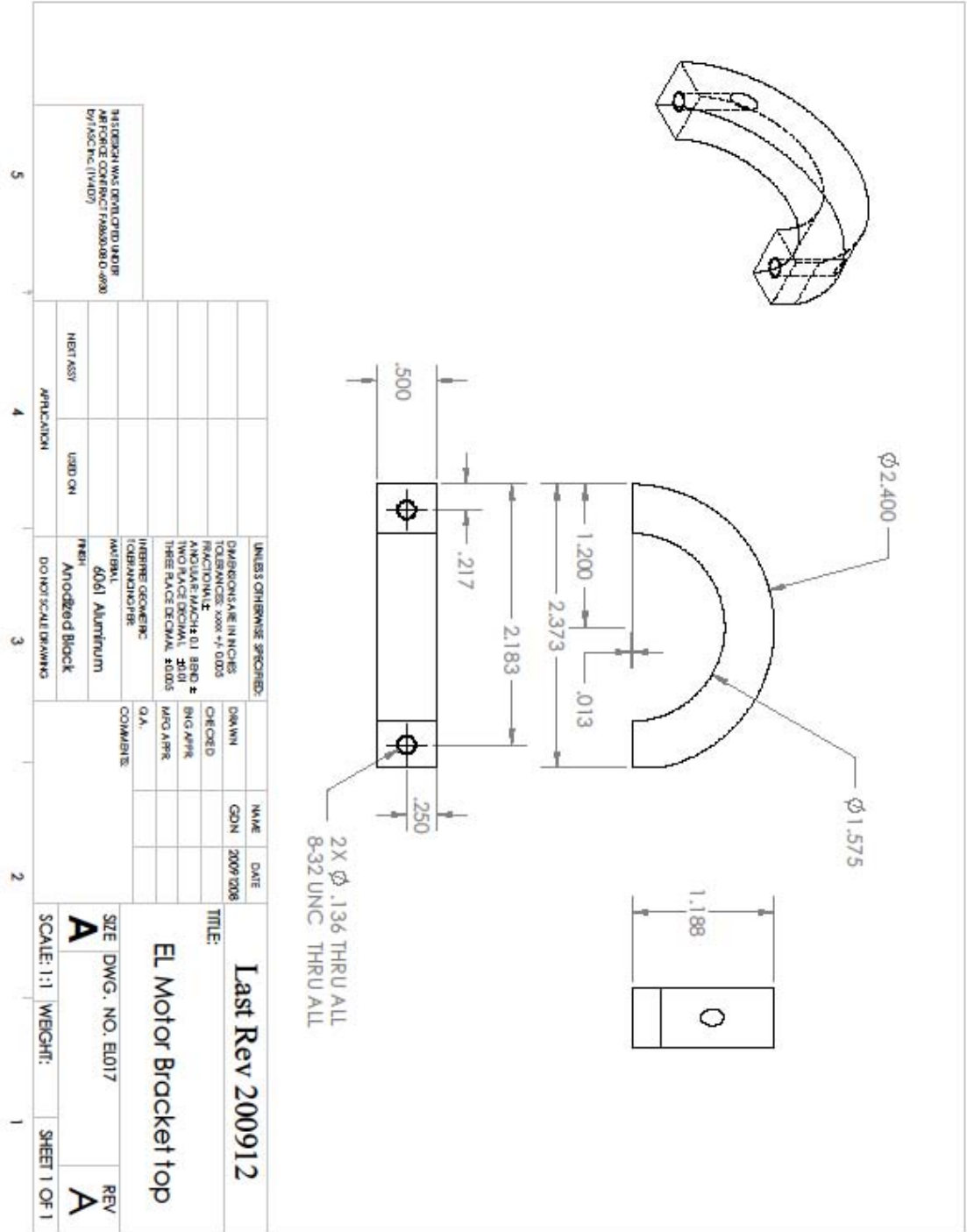

Figure 68: Elevation Motor Bracket Top

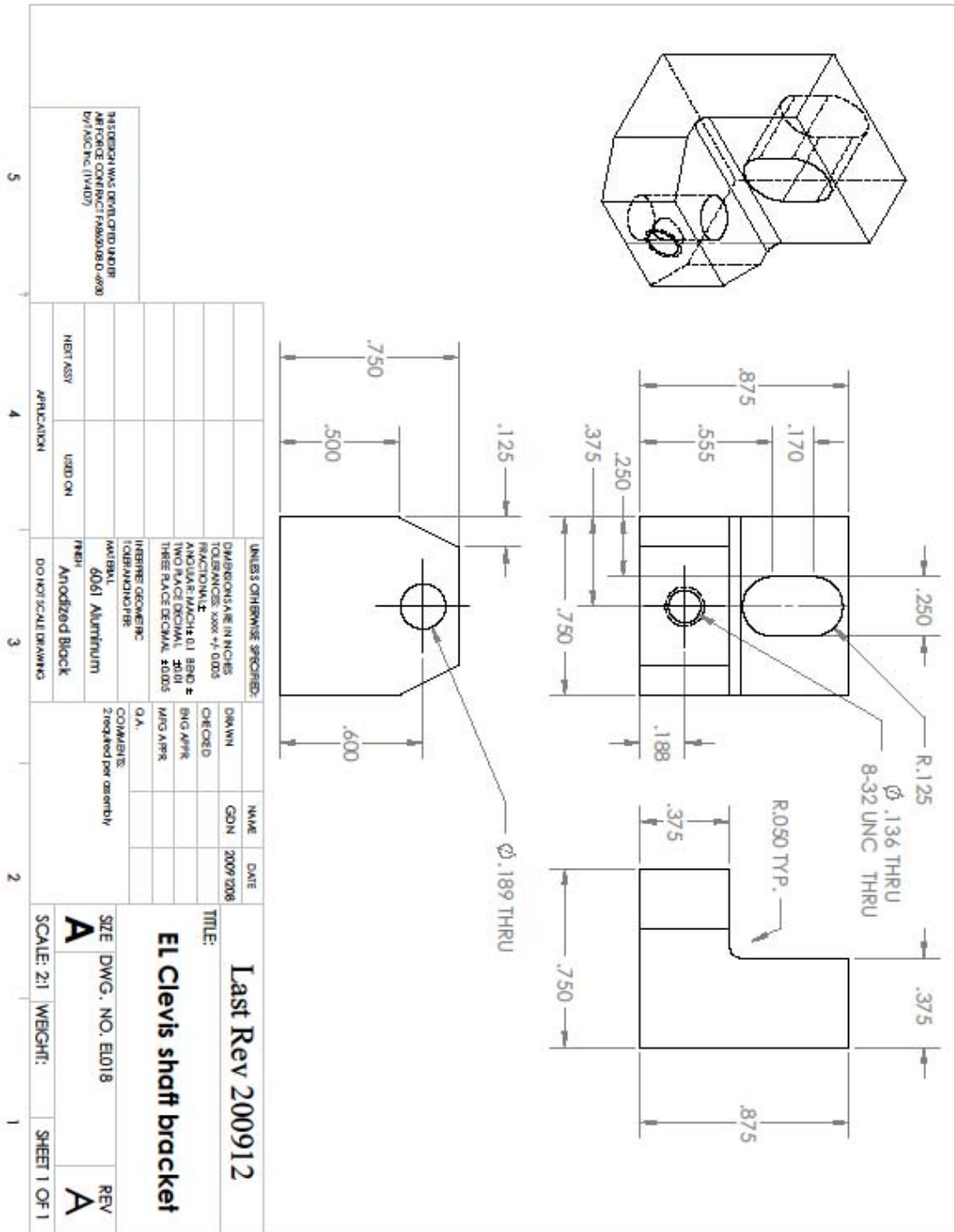

Figure 69: Elevation Clevis Shaft Bracket

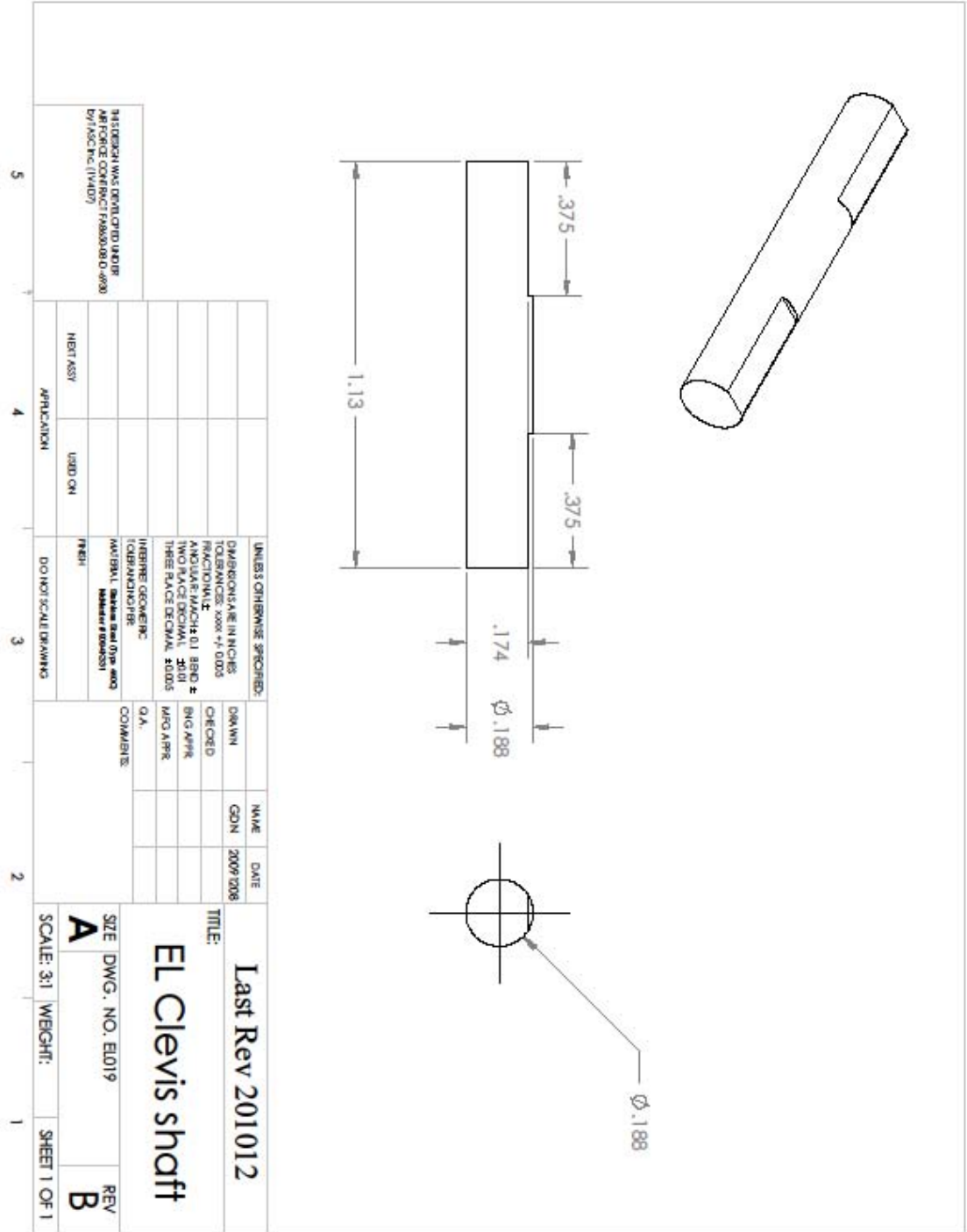

Figure 70: Elevation Clevis Shaft

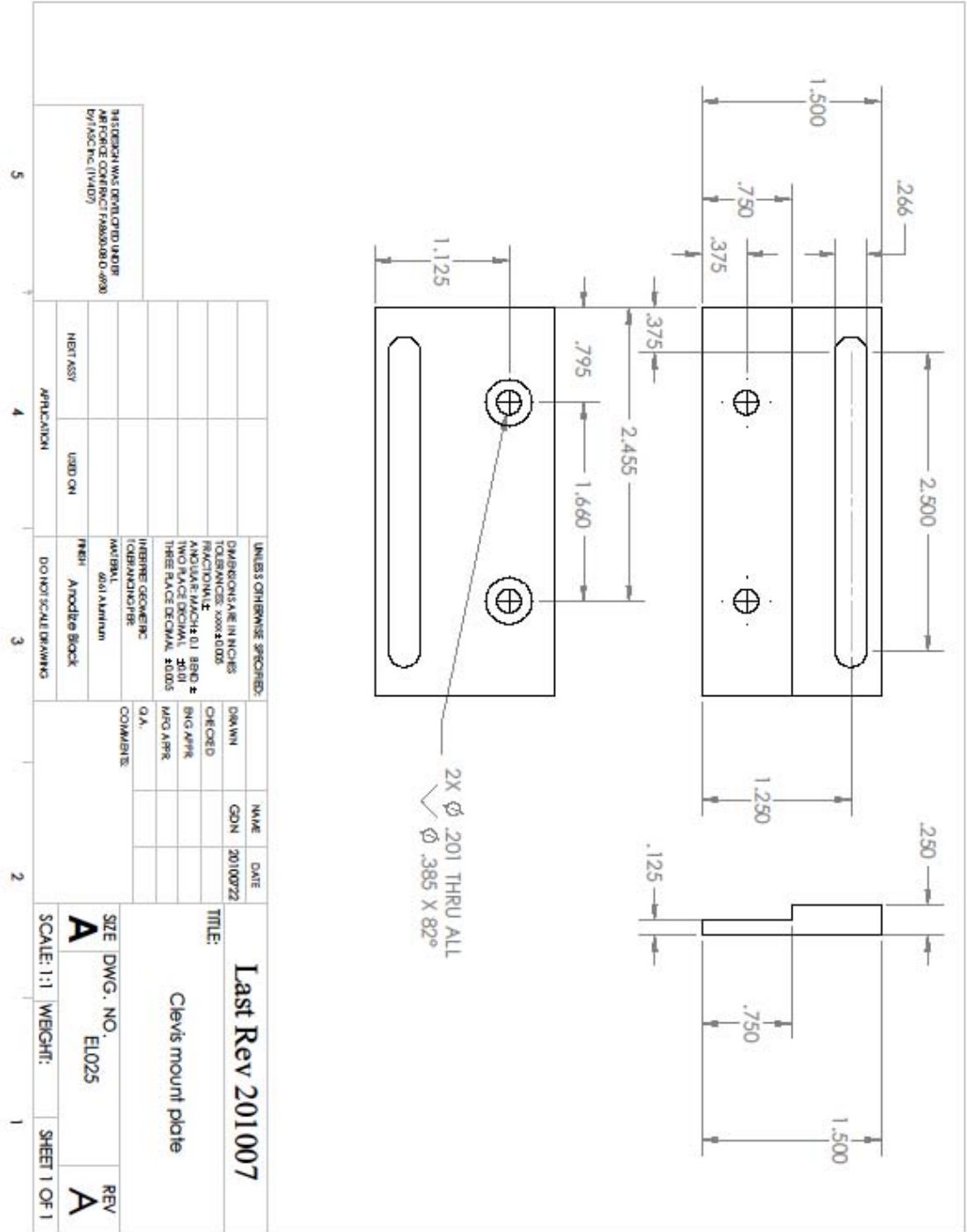

Figure 71: Elevation Clevis Mount Plate



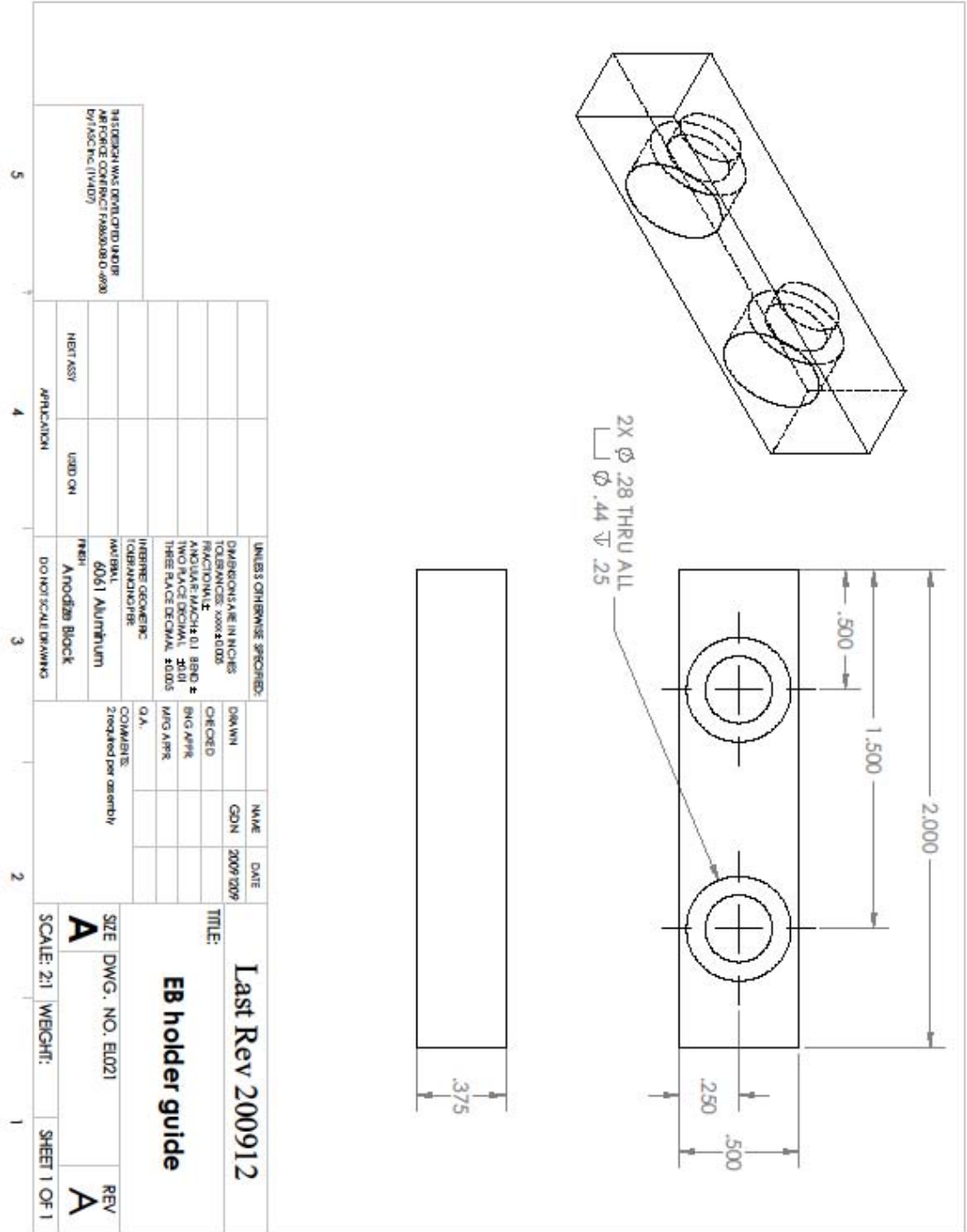

Figure 73: Ear Bar Holder Guide

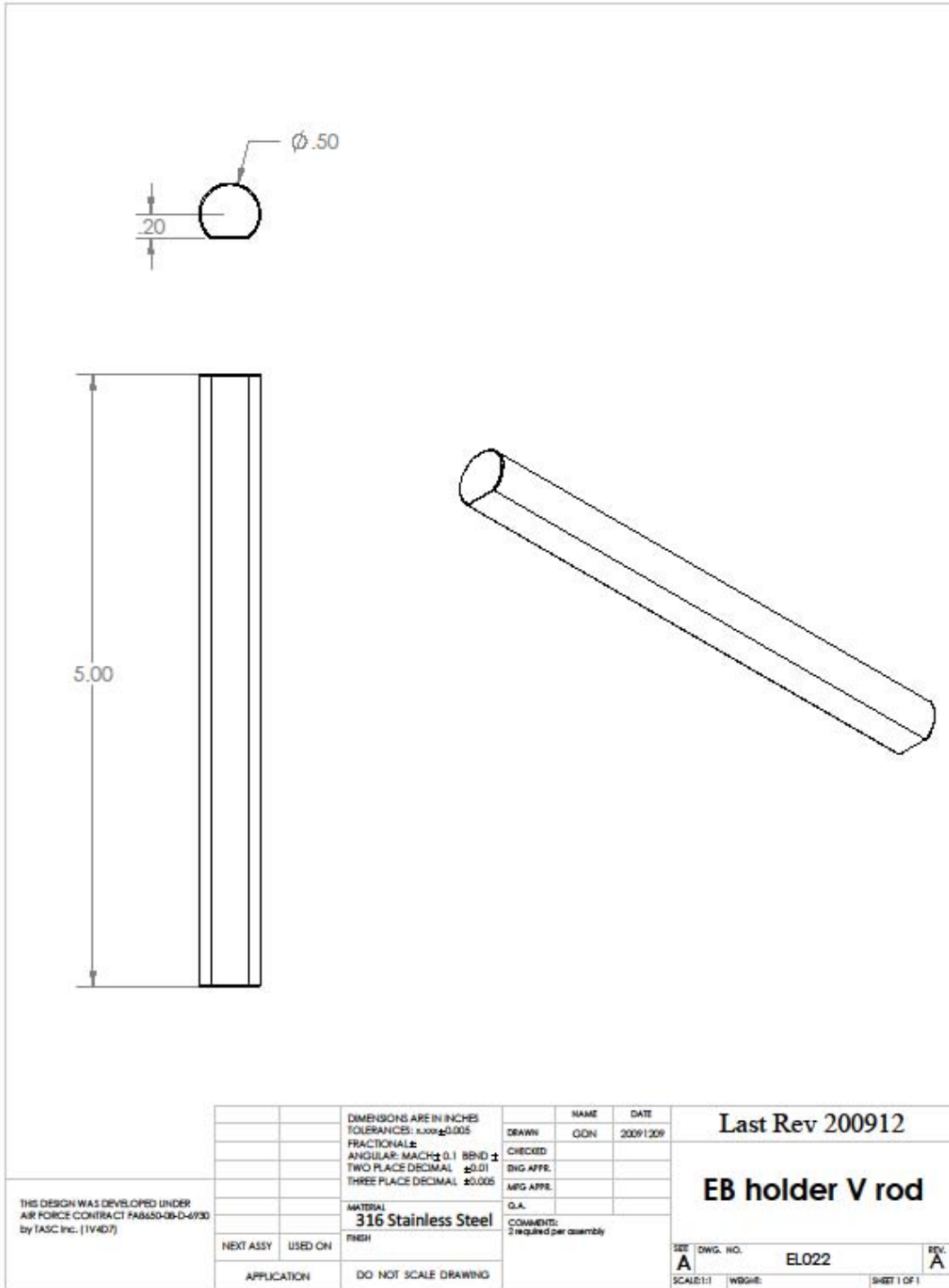

Figure 74: Ear Bar Vertical Rod

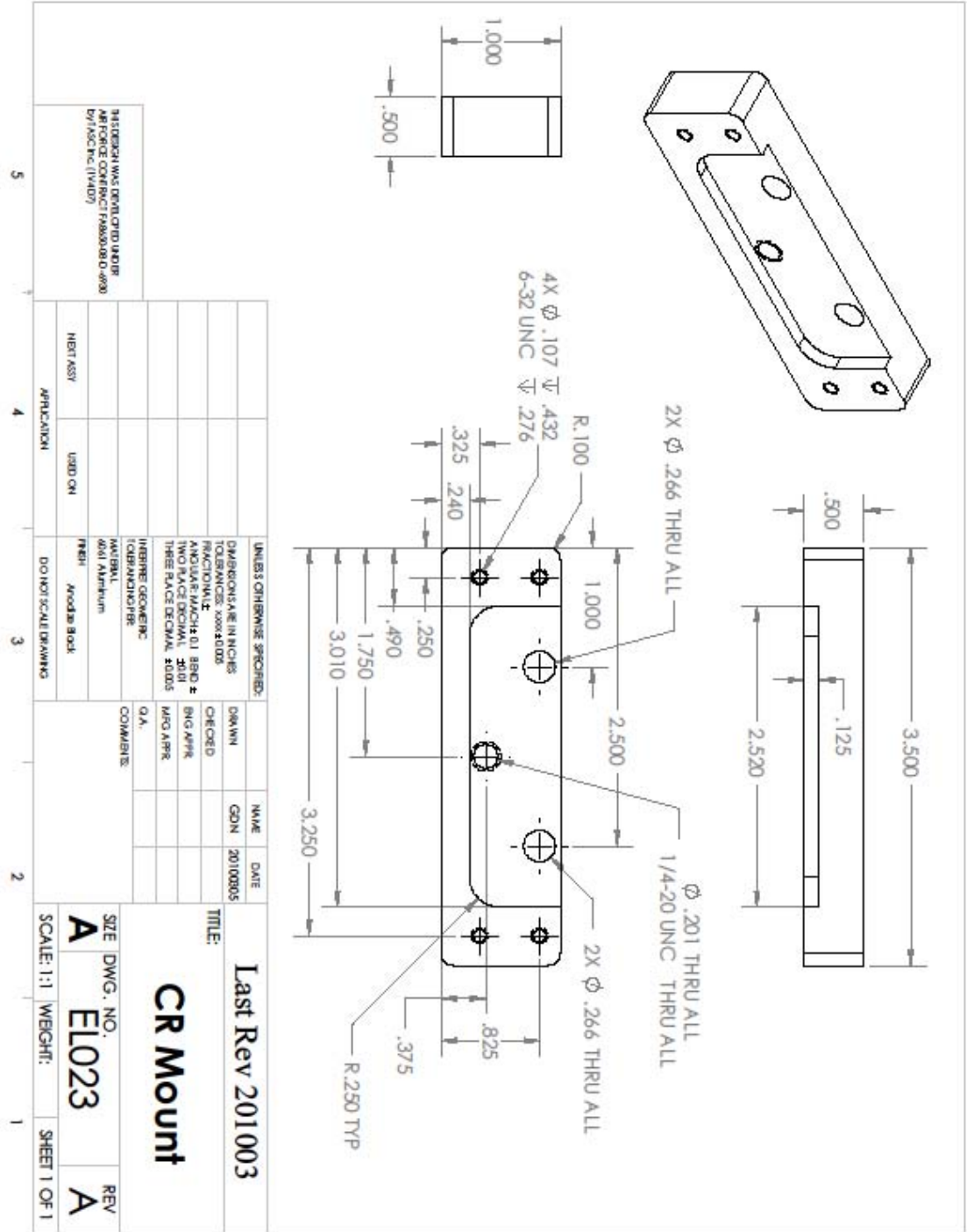

Figure 75: Chin Rest Mount



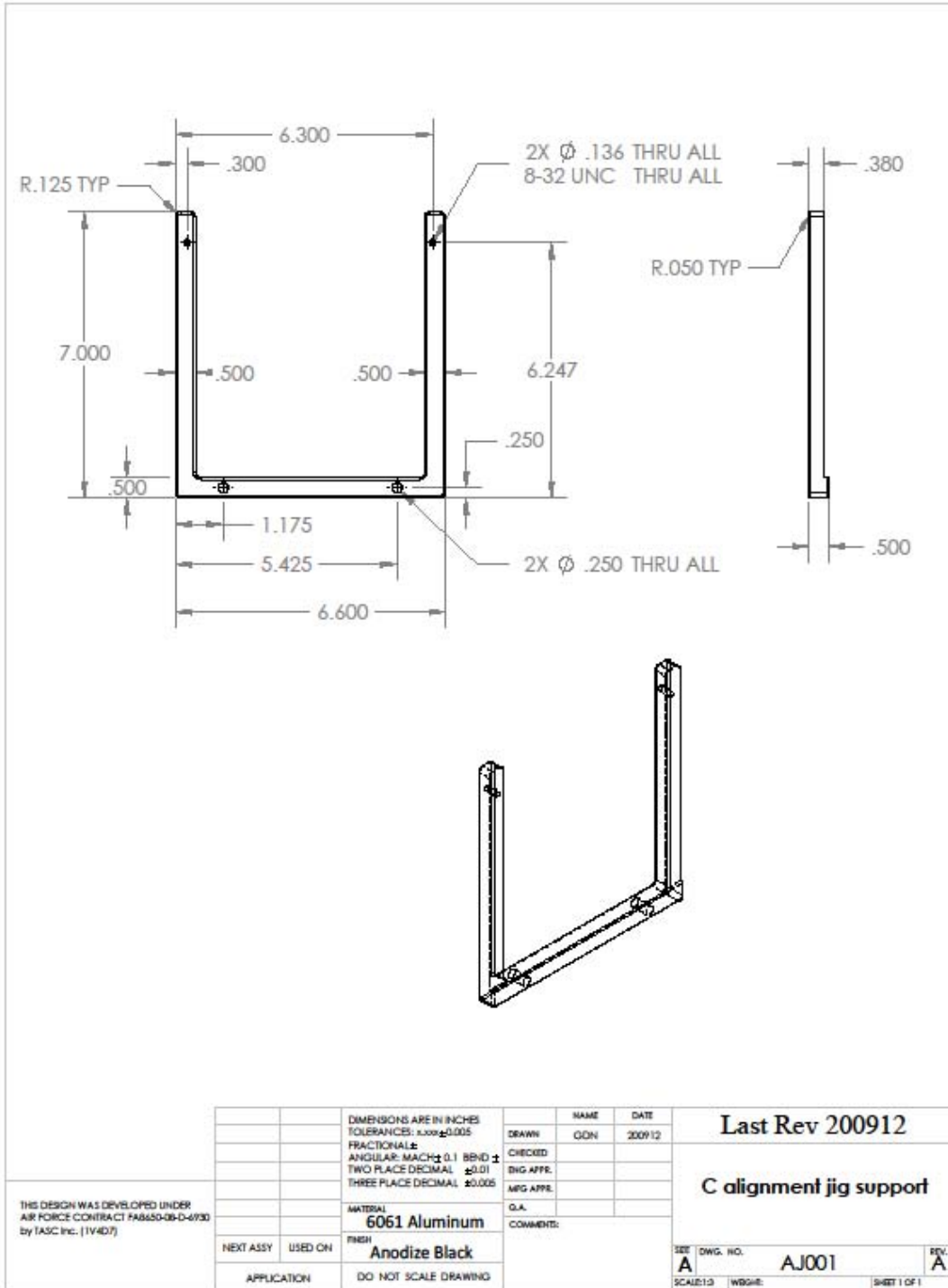

Figure 77: Cornea Alignment Jig Support

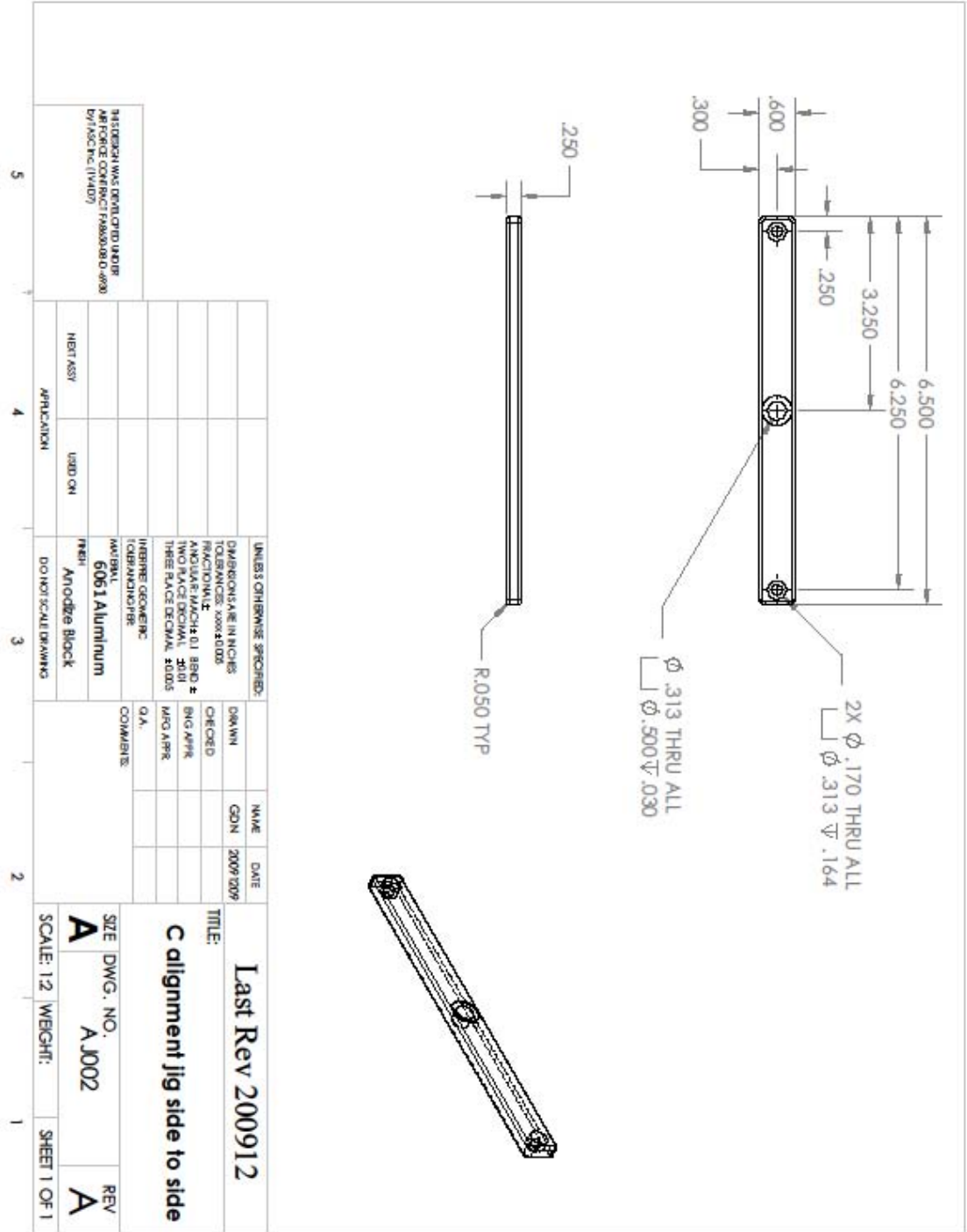

Figure 78: Cornea Alignment Jig Cross Support

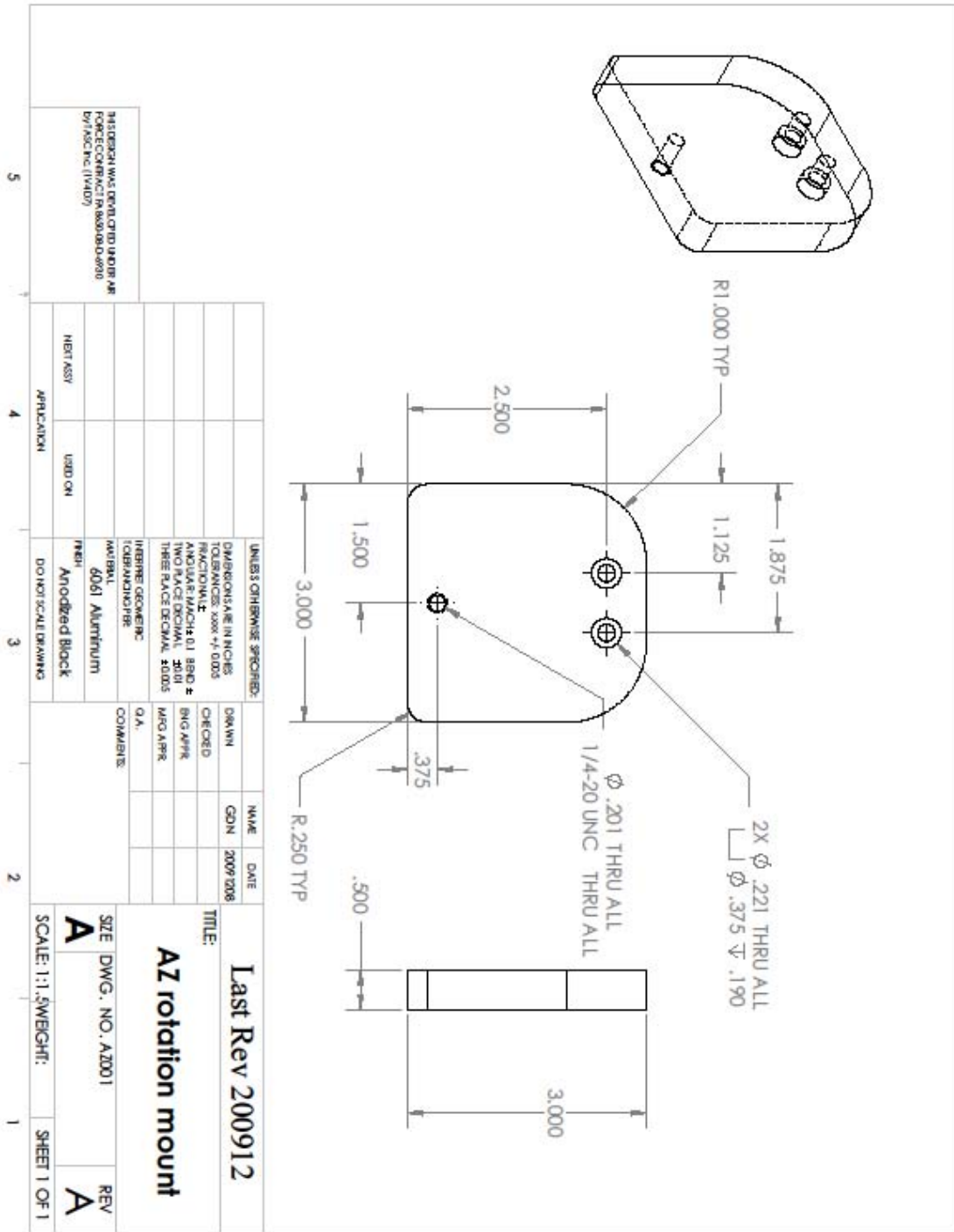

Figure 79: Azimuth Rotation Mount

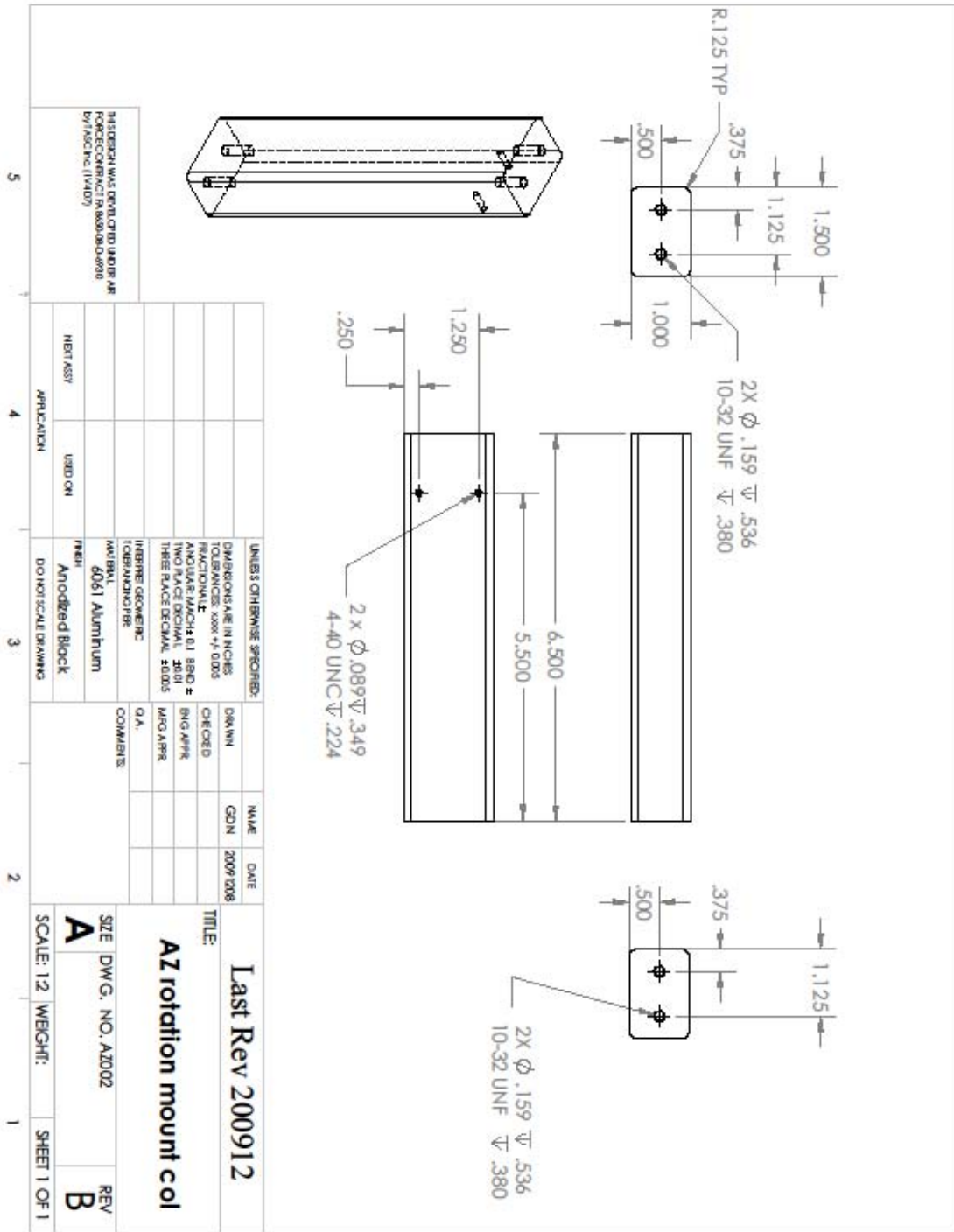
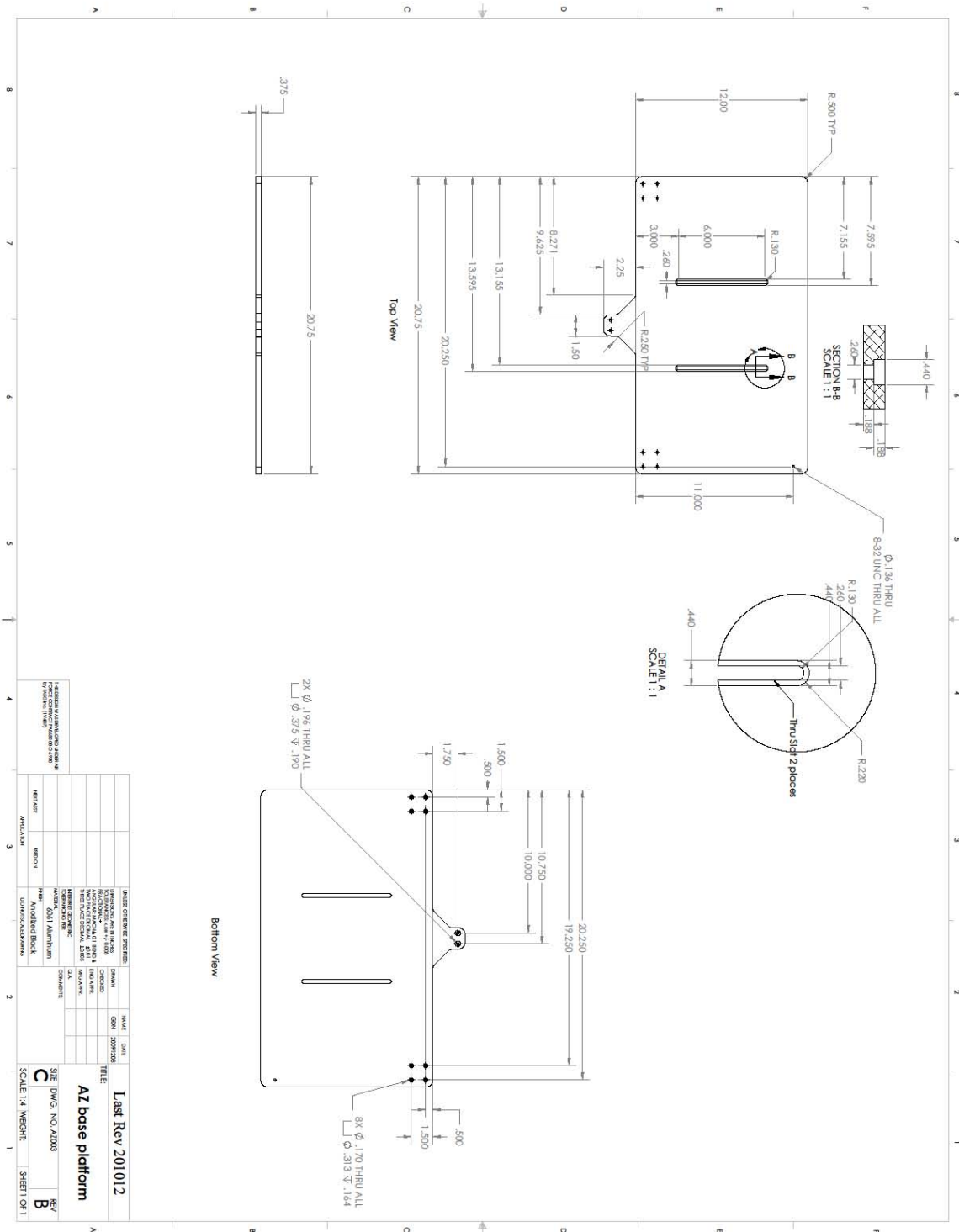

Figure 80: Azimuth Rotation Mount Column



**Figure 81: Azimuth Base Platform**

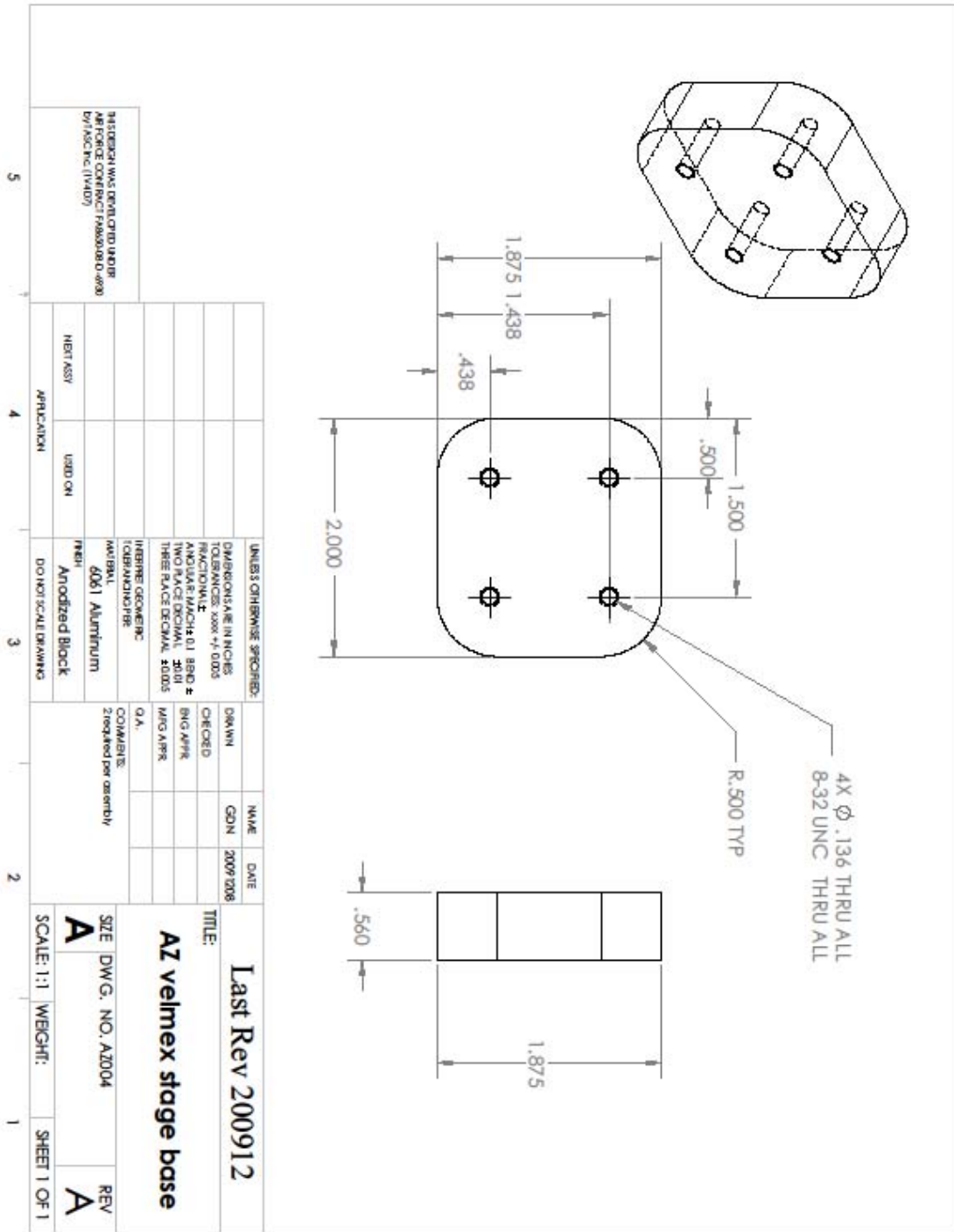
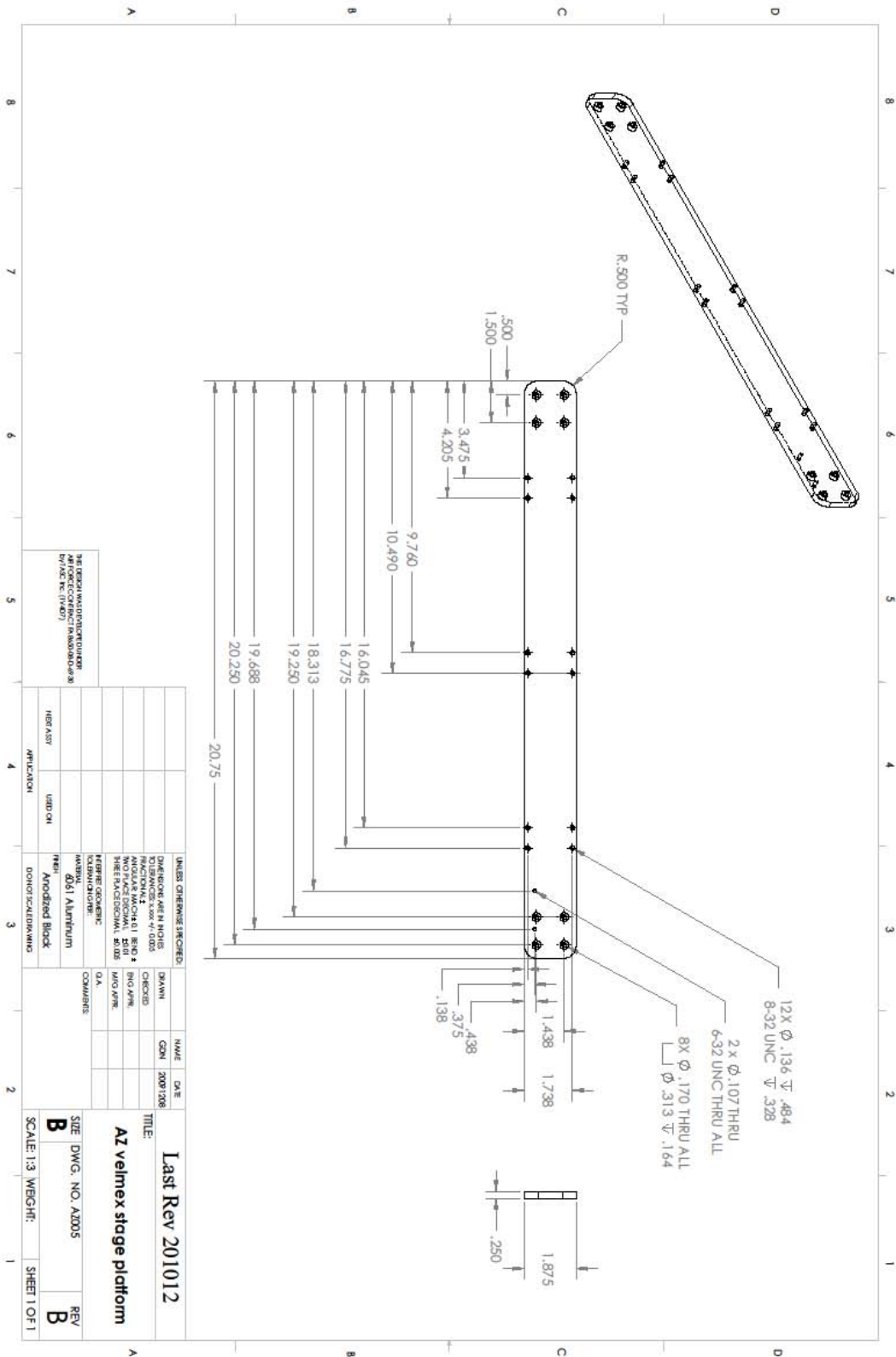

Figure 82: Azimuth Velmex Stage Base



UNLESS OTHERWISE SPECIFIED:	NAME	DATE
DRAWN BY: N. J. NOBLE	GN	2007/208
CHECKED BY: N. J. NOBLE		
DESIGNED BY: N. J. NOBLE		
APPROVED BY: N. J. NOBLE		
DATE: 10/10/07		
SCALE: 1:3		
TITLE: <b>Last Rev 201012</b>		
<b>AZ Velinex stage platform</b>		
SIZE: DWG. NO. A2005		
SCALE: 1:3	WBG/HK:	SHEET 1 OF 1
REV: B		
APP: N. J. NOBLE		
DATE: 10/10/07		
PROJECT: AZ Velinex stage platform		
DRAWN BY: N. J. NOBLE		
CHECKED BY: N. J. NOBLE		
DESIGNED BY: N. J. NOBLE		
APPROVED BY: N. J. NOBLE		
DATE: 10/10/07		
SCALE: 1:3		
TITLE: <b>Last Rev 201012</b>		
<b>AZ Velinex stage platform</b>		
SIZE: DWG. NO. A2005		
SCALE: 1:3	WBG/HK:	SHEET 1 OF 1
REV: B		
APP: N. J. NOBLE		
DATE: 10/10/07		
PROJECT: AZ Velinex stage platform		

Figure 83: Azimuth Velmex Stage Platform

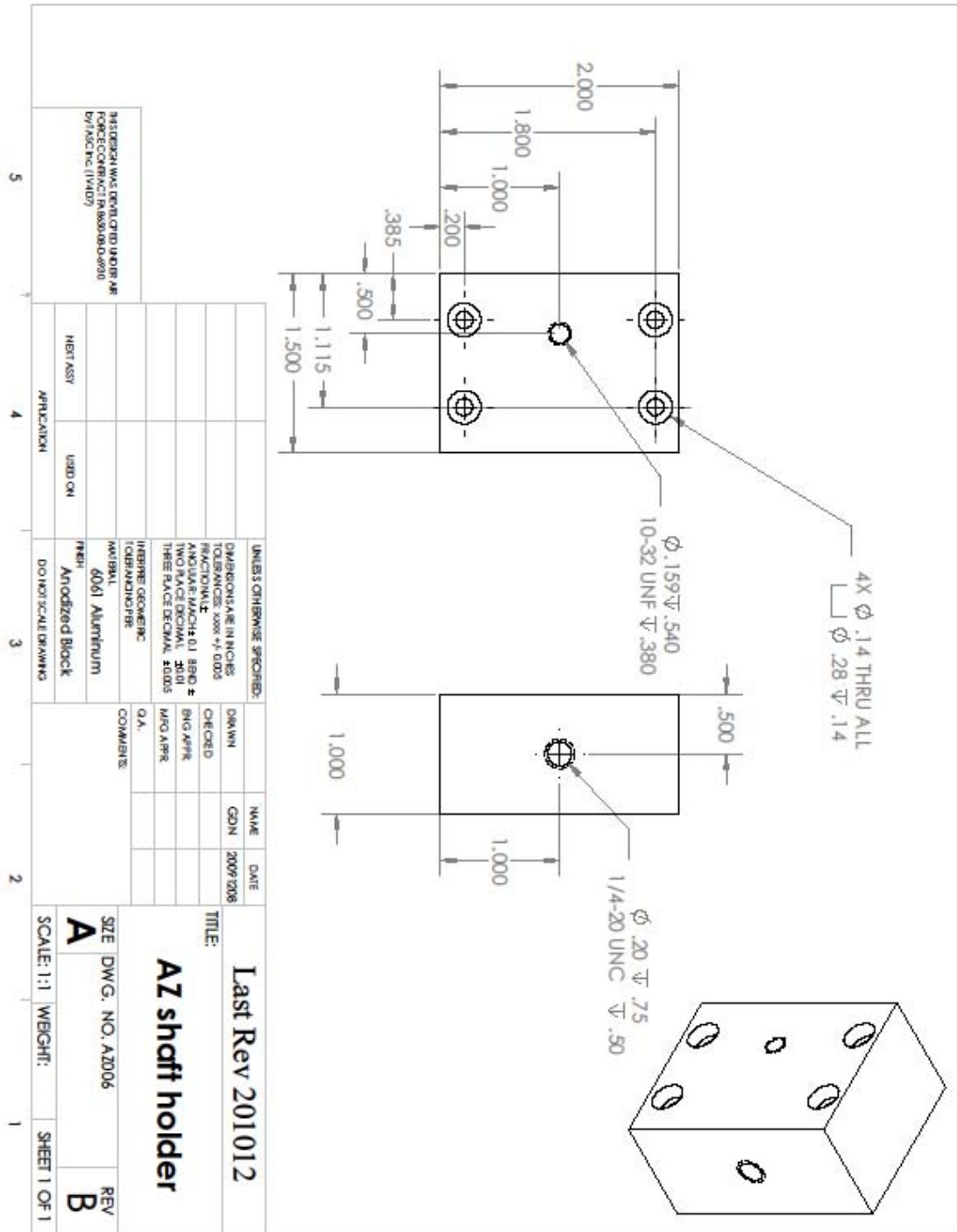

Figure 84: Azimuth Shaft Holder

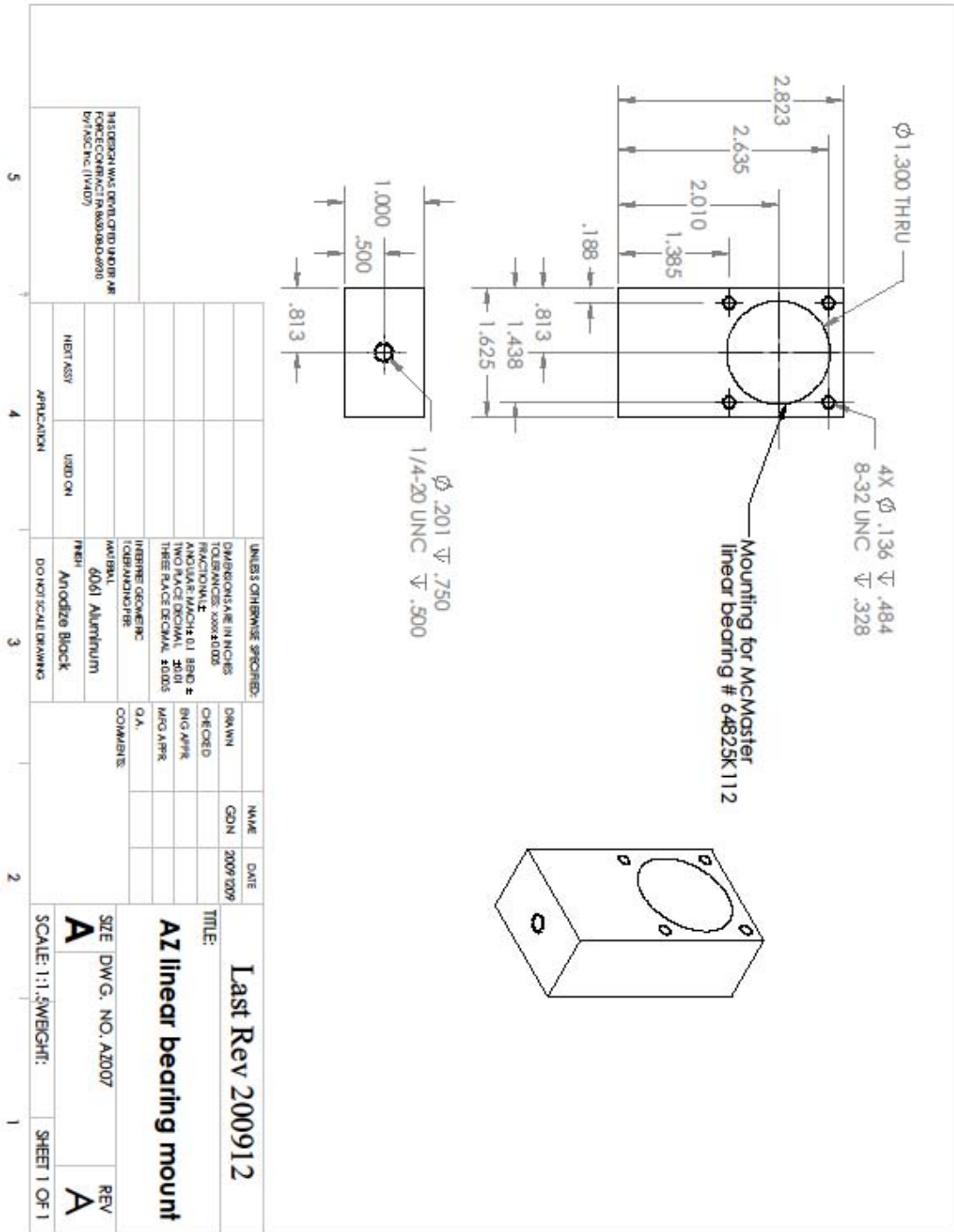

Figure 85: Azimuth Linear Bearing Mount

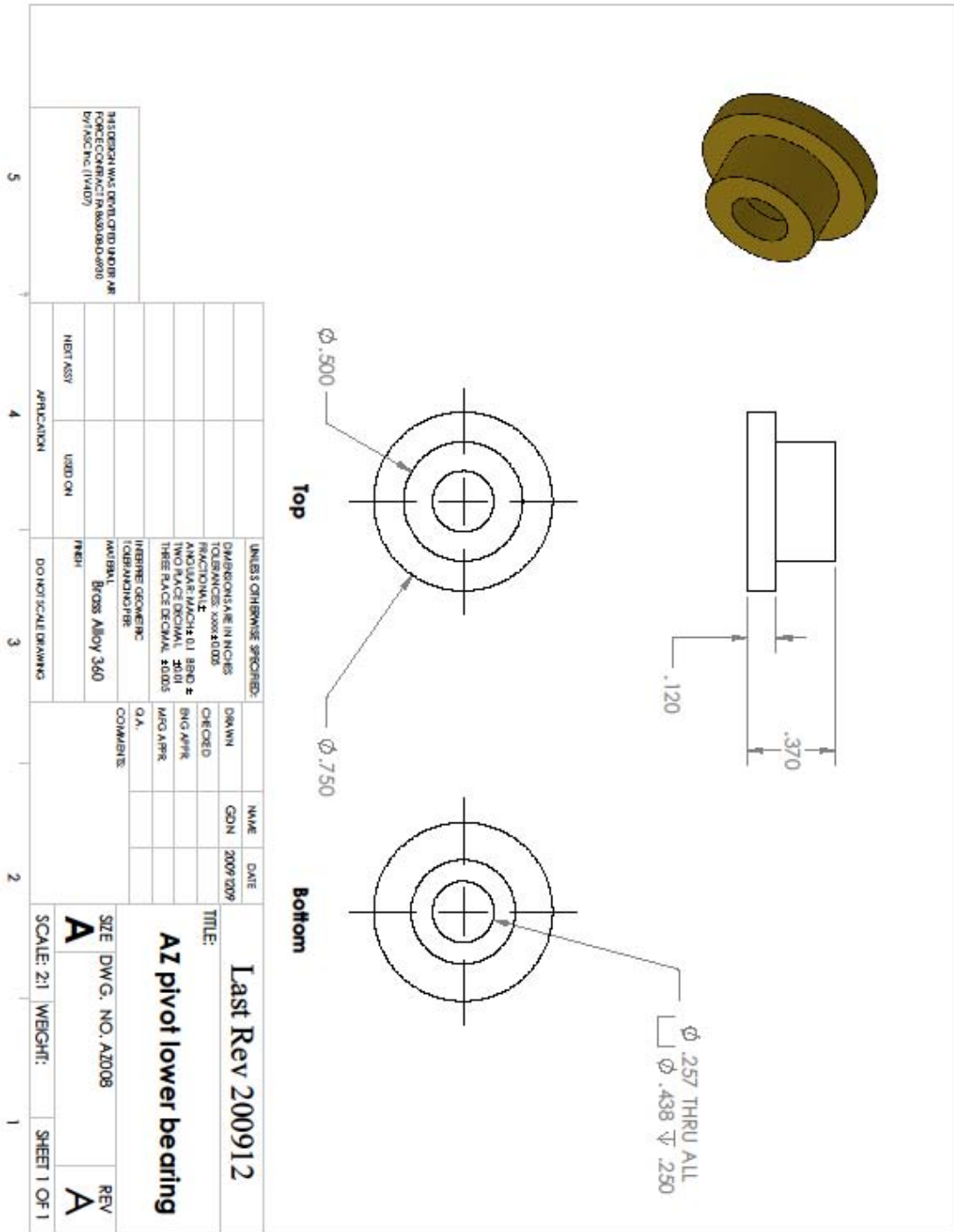

Figure 86: Azimuth Pivot Lower Bearing

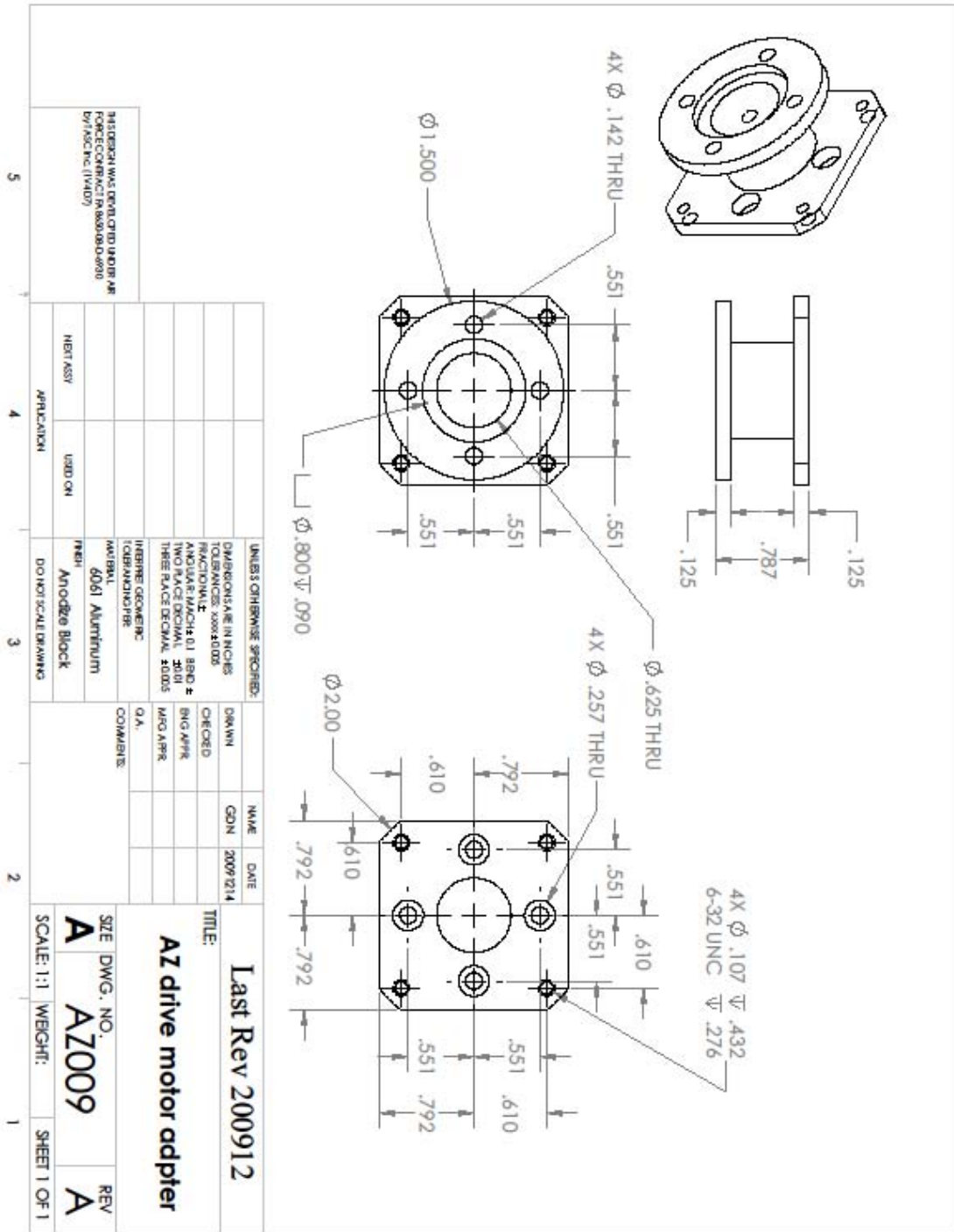

Figure 87: Azimuth Drive Motor Adapter

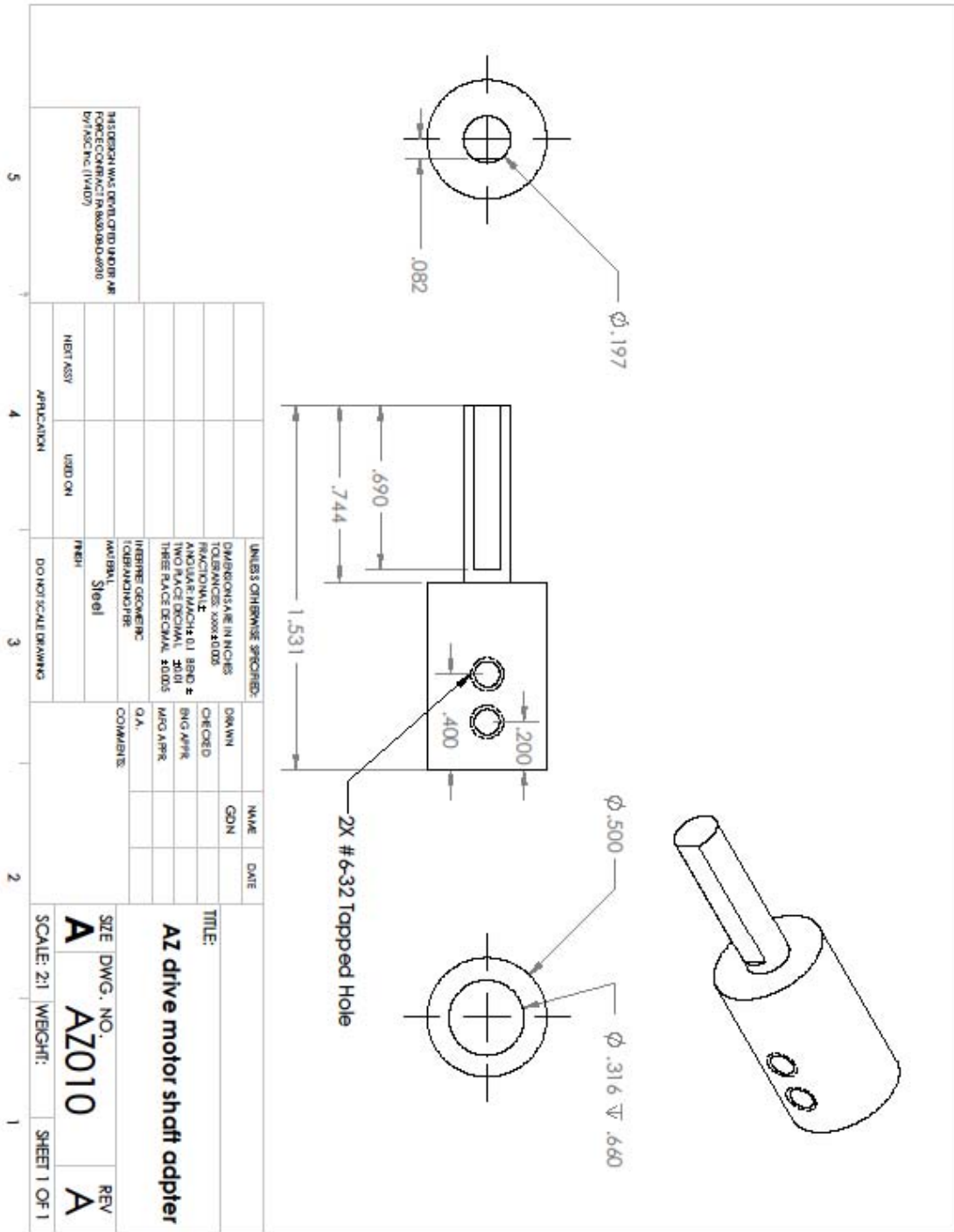

Figure 88: Azimuth Drive Motor Shaft Adapter

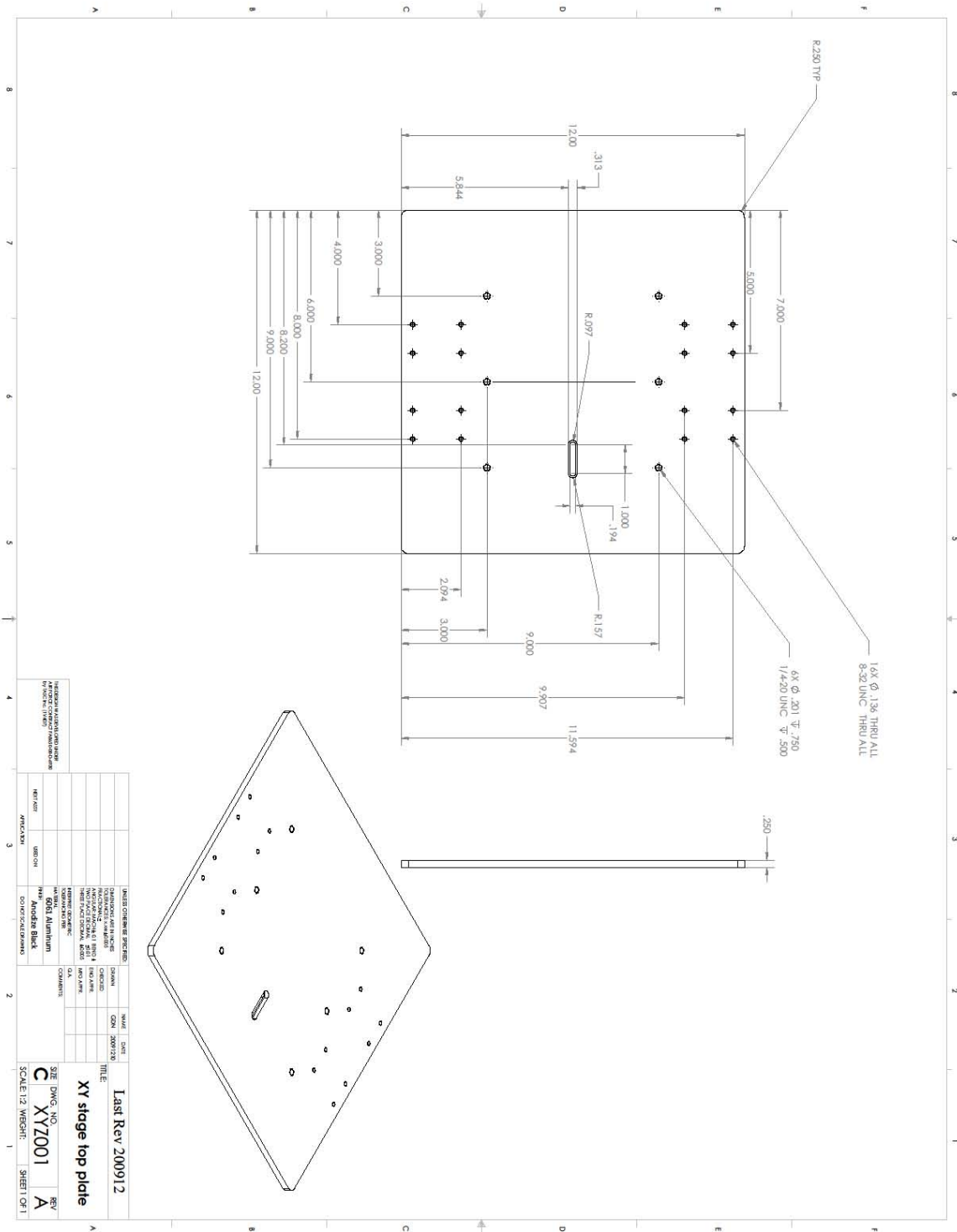
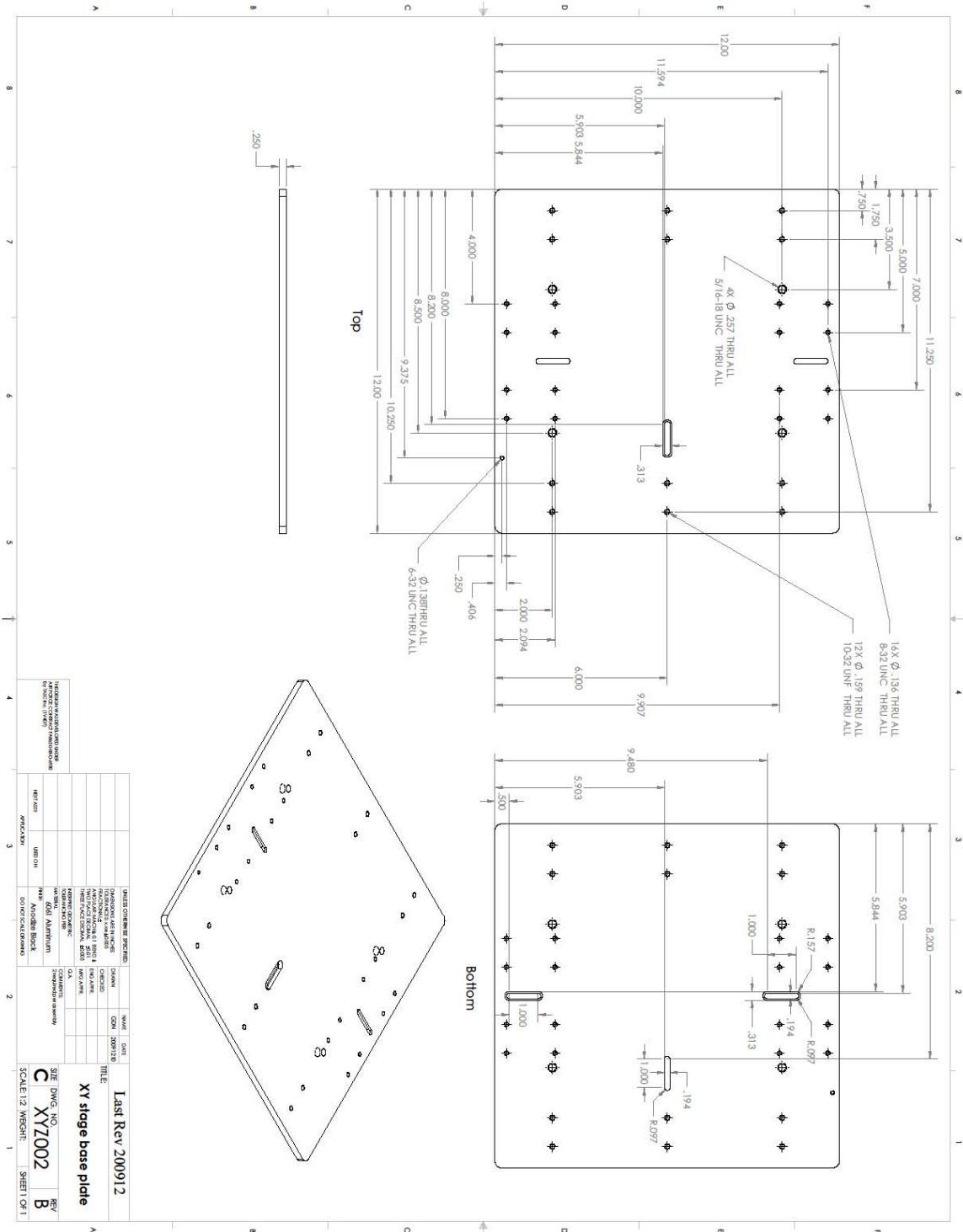

Figure 89: XY Stage Top Plate



DESIGN CHECKING SHEET		DATE	REV
DESIGNED BY	CHKD BY	2009/12/30	
DRAWN BY	CHKD BY		
INSTRUMENTED BY	CHKD BY		
TESTED BY	CHKD BY		
APPROVED BY	CHKD BY		
DATE	REV	TITLE	
		Last Rev 200912	
		XY stage base plate	
SCALE	SCALE	SCALE	SCALE
C	XYZ002	REV	B
SCALE 1:2	WEIGHT:	SHEET	OF 1

Figure 90: XY Stage Base Plate

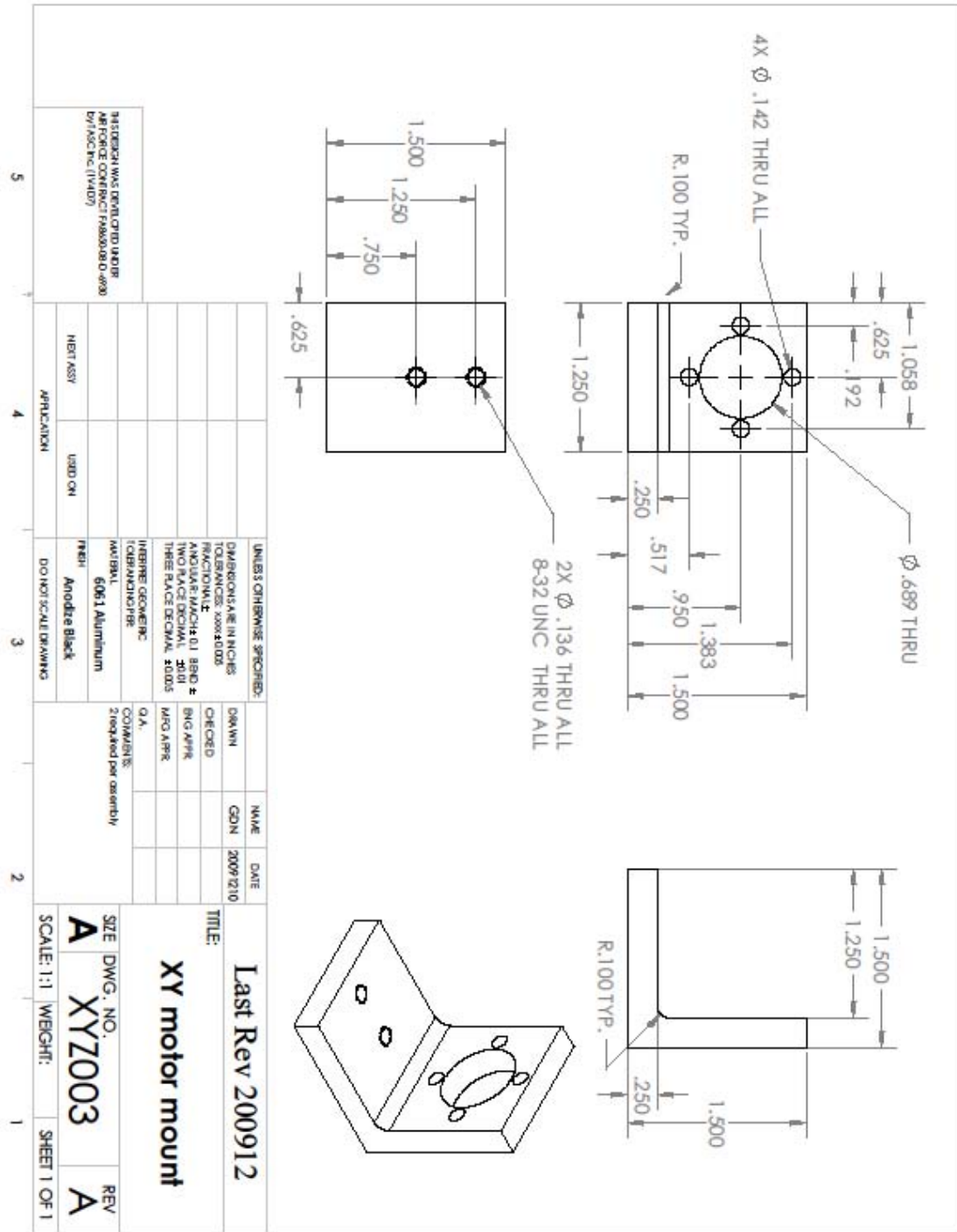

Figure 91: XY Motor Mount

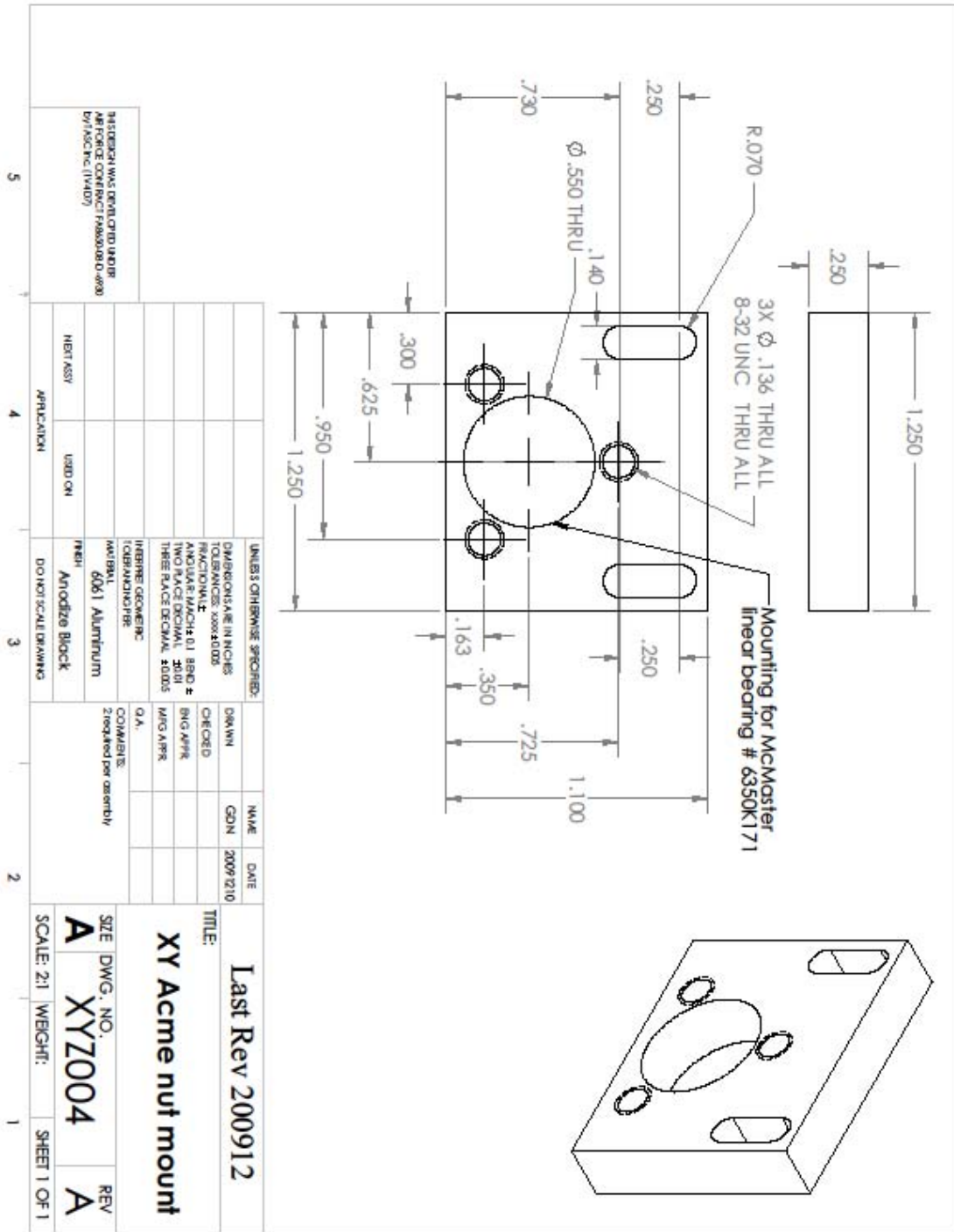

Figure 92: XY Acme Nut Mount

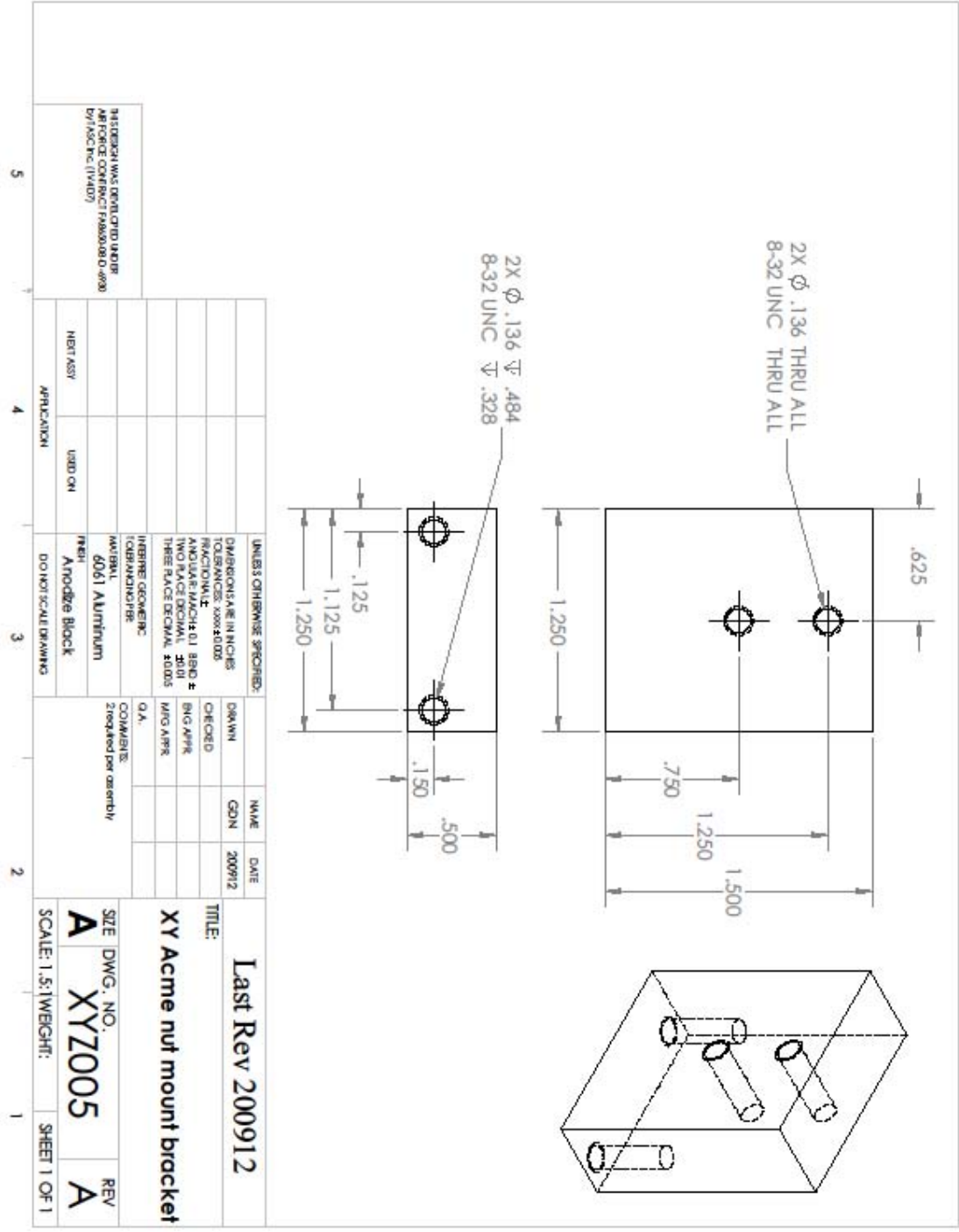

Figure 93: XY Acme Nut Mount Bracket

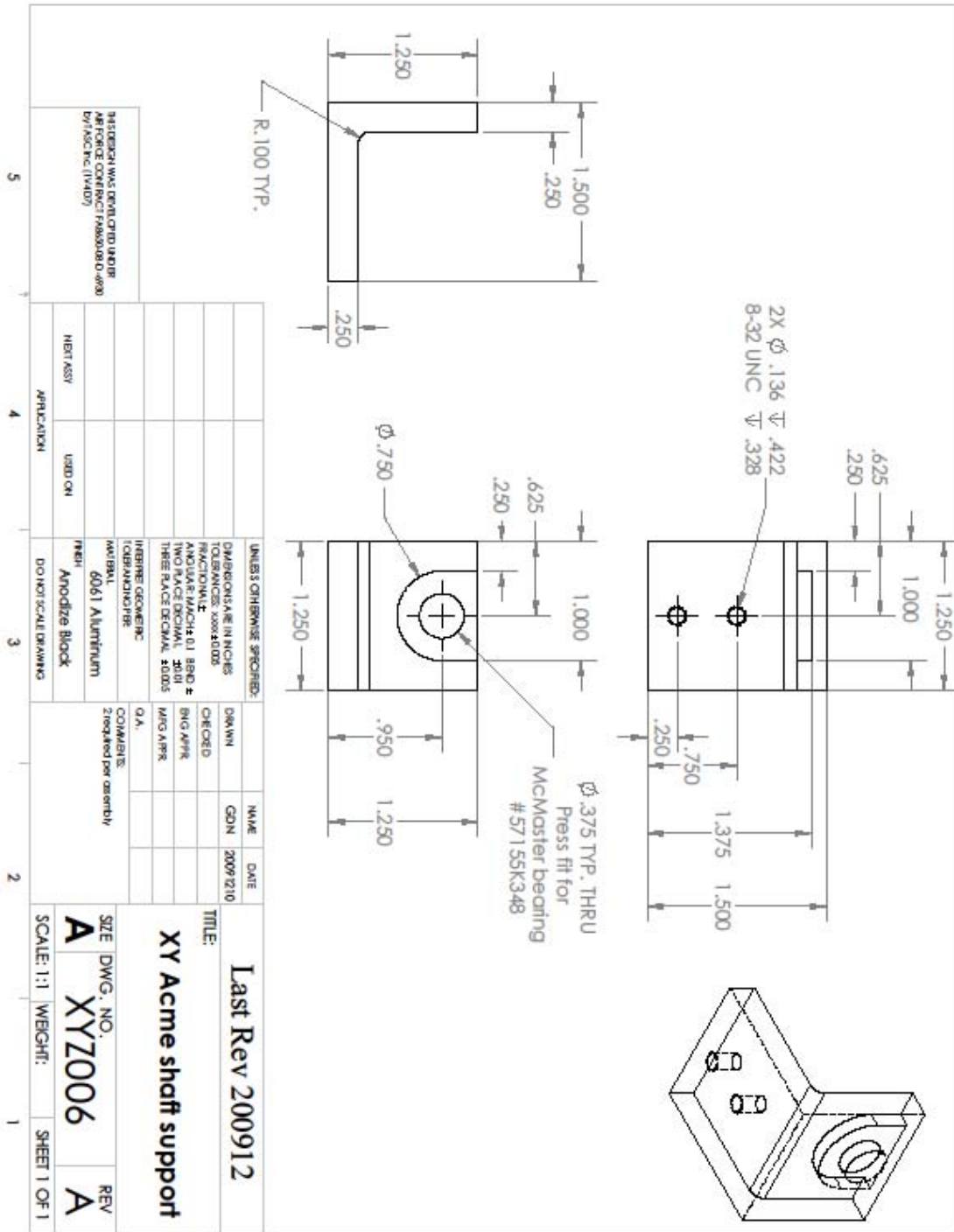

Figure 94: XY Acme Shaft Support

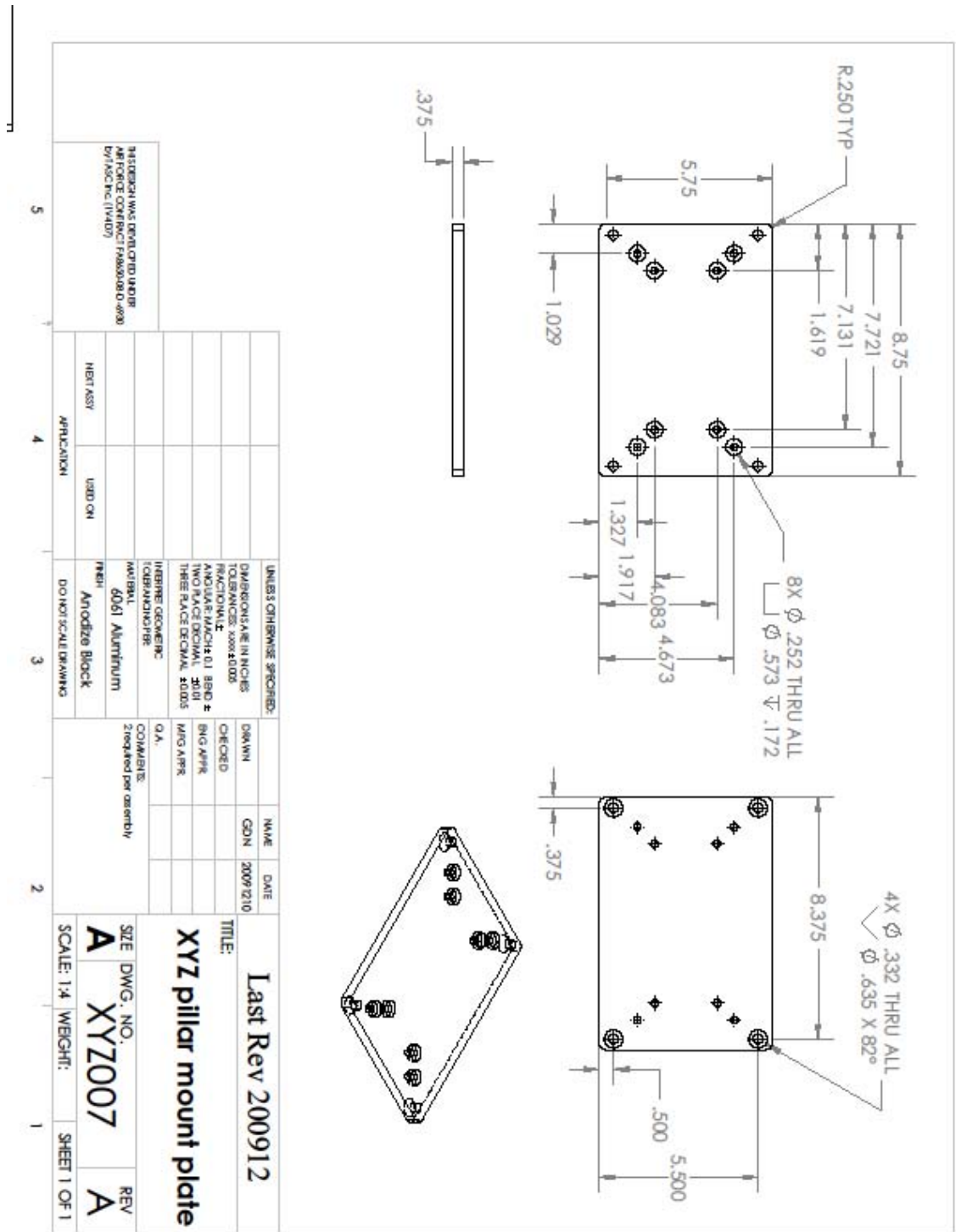
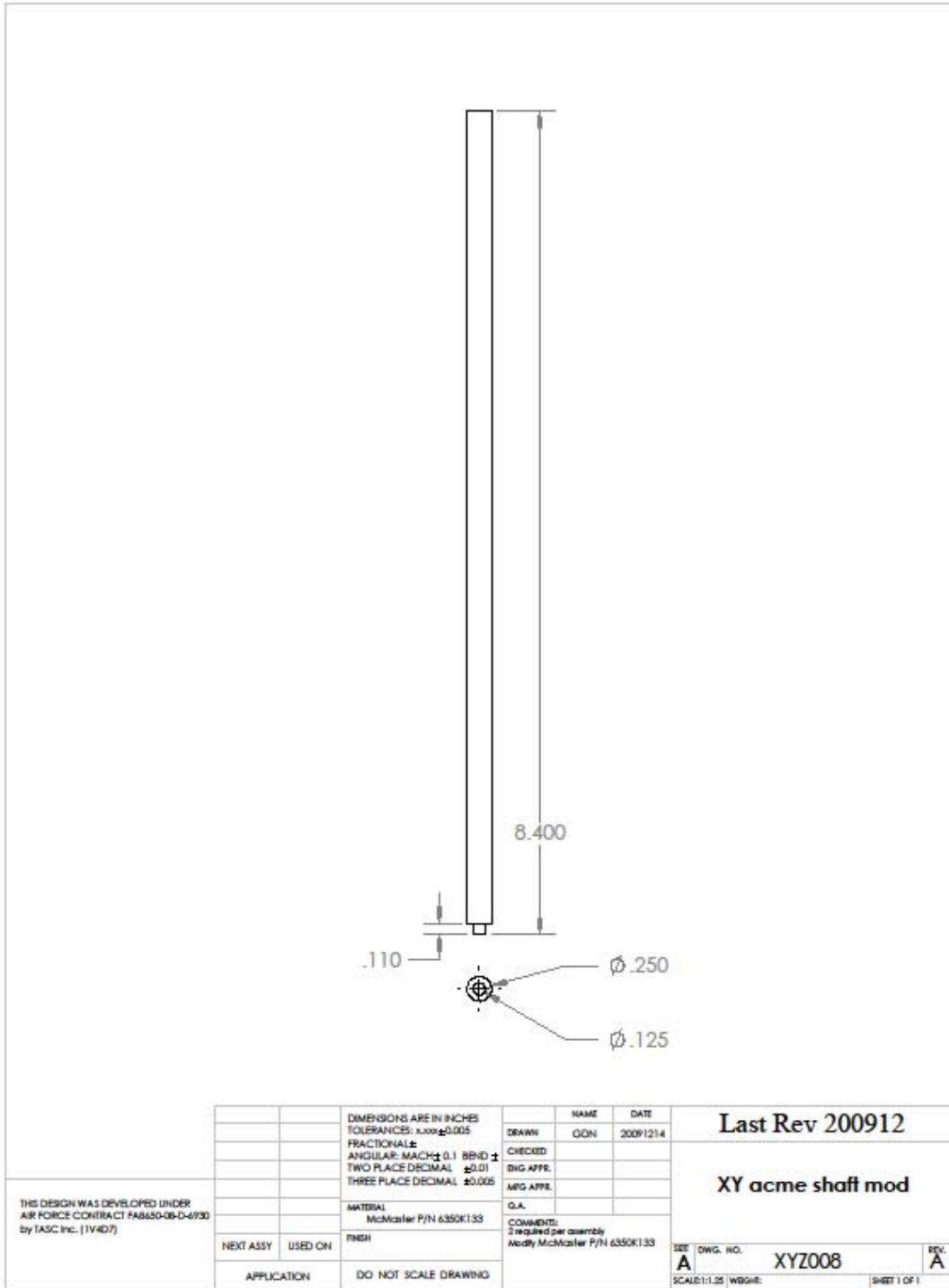

Figure 95: XYZ Pillar Mount Plate



**Figure 96: XY Acme Shaft Modification**

